



April 1, 2013

VIA HAND DELIVERY

Ms. Ann Cole
Division of the Commission Clerk and
Administrative Services
Florida Public Service Commission
Betty Easley Conference Center
2540 Shumard Oak Boulevard, Room 110
Tallahassee, FL 32399-0850

RECEIVED-FPSC
13 APR - 1 AM 11:52
COMMISSION
CLERK

130000-01

RE: Florida Power & Light Company's 2013 Ten-Year Power Plant Site Plan

Dear Ms. Cole:

In accordance with Rule 25-22.071, F.A.C., please find enclosed for filing the original and twenty-five (25) copies of Florida Power & Light Company's 2013-2022 Ten-Year Power Plant Site Plan.

Sincerely,

[Handwritten signature]
for

Jessica A. Cano
Principal Attorney

Enclosures

COM	_____
AFD	_____
APA	_____
ECO	_____
ENG	24
GCL	1
IDM	_____
TEL	_____
CLK	_____

DOCUMENT NUMBER-DATE

01579 APR-1 2013

Ten Year Power Plant Site Plan 2013-2022



FPL

DOCUMENT NUMBER-DATE

01579 APR-1 2013

FPSC-COMMISSION CLERK



FPL

Ten Year Power Plant Site Plan

2013-2022

Submitted To:

*Florida Public
Service Commission*

*Miami, Florida
April 2013*

DOCUMENT NUMBER-DATE

01579 APR-1 2

FPSC-COMMISSION CLERK

(This page is intentionally left blank.)

Table of Contents

List of Figures and Tables.....	iii
List of Schedules	iv
Overview of the Document	1
List of Abbreviations	3
Executive Summary	5
I. Description of Existing Resources	13
A. FPL-Owned Resources	15
B. Firm Capacity Power Purchases	22
C. Non-Firm (As Available) Energy Purchases.....	26
D. Demand Side Management (DSM).....	26
II. Forecast of Electric Power Demand	29
A. Overview of the Load Forecasting Process	31
B. Comparison of FPL's Current and Previous Load Forecasts	32
C. Long-Term Sales Forecasts	33
D. Net Energy for Load	36
E. System Peak Forecasts	38
F. Hourly Load Forecast	40
G. Uncertainty	40
H. DSM	41
III. Projection of Incremental Resource Additions	49
A. FPL's Resource Planning	51
B. Projected Incremental Resource Additions/Changes	59
C. Discussion of the Projected Resource Plan and Issues Impacting FPL's Resource Planning Work.....	62
D. Demand Side Management (DSM)	70
E. Transmission Plan.....	75
F. Renewable Resources.....	83
G. FPL's Fuel Mix and Price Forecasts.....	89
IV. Environmental and Land Use Information	123
A. Protection of the Environment	125
B. FPL's Environmental Statement	126
C. Environmental Management	127
D. Environmental Assurance Program	127
E. Environmental Communication and Facilitation	128
F. Preferred and Potential Sites	128
1. Preferred Site # 1 - Turkey Point Plant.....	129
2. Preferred Site # 2 - Cape Canaveral Plant.....	141
3. Preferred Site # 3 - Riviera Beach Plant	146
4. Preferred Site # 4 - Port Everglades Plant	151

5. Preferred Site # 5 - Hendry County	156
6. Preferred Site # 6 – NE Okeechobee County	159
7. Preferred Site # 7 – Palatka Site.....	163
8. Potential Site # 1 - Babcock Ranch	168
9. Potential Site # 2 - DeSoto Solar Expansion.....	168
10. Potential Site # 3 - Manatee Plant Site.....	169
11. Potential Site # 4 - Martin County	170
12. Potential Site # 5 – Putnam County	171

V. Other Planning Assumptions and Information	229
Introduction	231
Discussion Item #1	231
Discussion Item #2	232
Discussion Item #3	232
Discussion Item #4	233
Discussion Item #5	233
Discussion Item #6	234
Discussion Item #7	234
Discussion Item #8	235
Discussion Item #9	236
Discussion Item #10	236
Discussion Item #11	237
Discussion Item #12	238

List of Figures and Tables

Table ES-1	Projected Capacity & Firm Purchase Power Changes	11
Table ES-2	Projected Capacity Changes and Reserve Margins for FPL	12
Figure I.A.1	Capacity Resources by Location (Map)	16
Table I.A.1	Capacity Resource by Unit Type	17
Table I.A.2	Combined Cycle and Combustion Turbine Components	18
Table I.A.3	Purchase Power Resources by Contract	19
Figure I.A.2	FPL Substation & Transmission System Configuration (Map)	20
Figure I.A.3	FPL Interconnection Diagram	21
Table I.B.1	FPL’s Firm Purchased Power Summer MW	24
Table I.B.2	FPL’s Firm Purchased Power Winter MW	25
Table I.C.1	As-Available Energy Purchases From Non-Utility Generators in 2012	26
Figure III.A.1	Overview of FPL’s IRP Process	52
Table III.B.1	Projected Capacity Changes for FPL	61
Table III.D.1	FPL’s Projected DSM Summer MW Reduction for 2013 - 2022	75
Table III.E.1	List of Proposed Power Lines	76
Table IV.E.1	2012 FPL Environmental Outreach Activities	128
	Preferred Site # 1 - Turkey Point Plant Maps	173
	Preferred Site # 2 - Cape Canaveral Plant Maps	179
	Preferred Site # 3 - Riviera Beach Plant Maps	185
	Preferred Site # 4 - Port Everglades Plant Maps	191
	Preferred Site # 5 - Hendry County Maps	197
	Preferred Site # 6 - Northeast Okeechobee County Maps	201
	Preferred Site # 7 - Palatka Site Maps	205
	Potential Site # 1 – Babcock Ranch Maps	209
	Potential Site # 2 – Desoto Solar Expansion Maps	213
	Potential Site # 3- Manatee Plant Maps	217
	Potential Site # 4 – Martin County Maps	221
	Potential Site # 5 – Putnam County Maps	225

List of Schedules

Schedule 1	Existing Generating Facilities.....	27
Schedule 2.1	History and Forecast of Energy Consumption & Number of Customers by Customer Class (Rural & Residential).....	42
Schedule 2.2	History and Forecast of Energy Consumption & Number of Customers by Customer Class (Industrial).....	43
Schedule 2.3	History and Forecast of Energy Consumption & Number of Customers by Customer Class (Sales for Resale).....	44
Schedule 3.1	History and Forecast of Summer Peak Demand (Base Case).....	45
Schedule 3.2	History and Forecast of Winter Peak Demand (Base Case).....	46
Schedule 3.3	History and Forecast of Annual Net Energy for Load GWh (Base Case).....	47
Schedule 4	Previous Year Actual and Two-Year Forecast of Retail Peak Demand and Net Energy for Load by Month.....	48
Schedule 5	Fuel Requirements.....	98
Schedule 6.1	Energy Sources.....	99
Schedule 6.2	Energy Sources % by Fuel Type.....	100
Schedule 7.1	Forecast of Capacity, Demand and Scheduled Maintenance at Time of Summer Peak.....	101
Schedule 7.2	Forecast of Capacity, Demand and Scheduled Maintenance at Time of Winter Peak.....	102
Schedule 7.3	Projection of Generation-Only Reserve at time of Summer Peak (assuming no additions in 2022).....	103
Schedule 7.4	Projection of Generation-Only Reserve at time of Summer Peak (assuming TP6 is added in 2022).....	104
Schedule 8	Planned and Prospective Generating Facility Additions and Changes	105
Schedule 9	Status Report and Specifications of Proposed Generating Facilities	107
Schedule 10	Status Report and Specifications of Proposed Transmission Lines	113
Schedule 11.1	Existing Firm and Non-Firm Capacity & Energy by Primary Fuel Type	121
Schedule 11.2	Existing Non- Firm Self-Service Renewable Generation Facilities	121

Overview of the Document

Chapter 186, Florida Statutes, requires that each electric utility in the State of Florida with a minimum existing generating capacity of 250 megawatts (MW) must annually submit a Ten Year Power Plant Site Plan. This plan should include an estimate of the utility's future electric power generating needs, a projection of how these estimated generating needs might be met, and disclosure of information pertaining to the utility's preferred and potential power plant sites. The information contained in this Site Plan is compiled and presented in accordance with rules 25-22.070, 25-22.071, and 25-22.072, Florida Administrative Code (F.A.C.).

This Ten Year Power Plant Site Plan (Site Plan) document is based on Florida Power & Light Company's (FPL) integrated resource planning (IRP) analyses that were carried out in 2012 and that were on-going in the first Quarter of 2013. The forecasted information presented in this plan addresses the years 2013 through 2022.

Site Plans are long-term planning documents and should be viewed in this context. A Site Plan contains uncertain forecasts and tentative planning information. Forecasts evolve, and all planning information is subject to change at the discretion of the utility. Much of the data submitted is preliminary in nature and is presented in a general manner. Specific and detailed data will be submitted as part of the Florida site certification process, or through other proceedings and filings, at the appropriate time.

This document is organized in the following manner:

Chapter I – Description of Existing Resources

This chapter provides an overview of FPL's current generating facilities. Also included is information on other FPL resources including purchased power, demand side management, and FPL's transmission system.

Chapter II – Forecast of Electric Power Demand

FPL's load forecasting methodology, and its forecast of seasonal peaks and annual energy usage, is presented in Chapter II.

Chapter III – Projection of Incremental Resource Additions

This chapter discusses FPL's integrated resource planning (IRP) process and outlines FPL's projected resource additions, especially new power plants, based on FPL's IRP work in 2012 and

early 2013. This chapter also discusses a number of issues that may change the resource plan presented in this Site Plan. Furthermore, this chapter discusses FPL's current DSM programs, renewable energy efforts, transmission planning additions, and fuel cost forecasts.

Chapter IV – Environmental and Land Use Information

This chapter discusses environmental information as well as Preferred and Potential site locations for additional electric generation facilities.

Chapter V – Other Planning Assumptions and Information

This chapter addresses twelve "discussion items" which pertain to additional information that is included in a Site Plan filing.

FPL
List of Abbreviations
Used in FPL Forms

Reference	Abbreviation	Definition
Unit Type	CC	Combined Cycle
	CT	Combustion Turbine
	GT	Gas Turbine
	IC	Internal Combustion
	ST	Nuclear Power
	PV	Photovoltaic
	ST	Steam Unit
Fuel Type	NP	Uranium
	BIT	Bituminous Coal
	FO2	#1, #2 or Kerosene Oil (Distillate)
	FO6	#4,#5,#6 Oil (Heavy)
	NG	Natural Gas
	No	None
	Solar	Solar Energy
	SUB	Sub Bituminous Coal
	Pet	Petroleum Coke
Fuel Transportation	No	None
	PL	Pipeline
	RR	Railroad
	TK	Truck
	WA	Water
Unit/Site Status	OT	Other
	P	Planned Unit
	T	Regulatory approval received but not under construction
	U	Under construction, less than or equal to 50% Complete
	V	Under construction, more than 50% Complete
Other	ESP	Electrostatic Precipitators

(This page is left intentionally blank.)

Executive Summary

Florida Power & Light Company's (FPL) 2013 Ten Year Power Plant Site Plan (Site Plan) presents FPL's current plans to augment and enhance its electric generation capability (owned or purchased) as part of its efforts to meet its projected incremental resource needs for the 2013 - 2022 time period. By design, the primary focus of this document is on supply side additions; i.e., electric generation capability and the sites for these additions. The supply side additions discussed in this document are resources projected to be needed after accounting for FPL's demand side management (DSM) resource additions previously approved by the Florida Public Service Commission (FPSC) and the significant energy efficiency contributions from the current federal appliance and lighting efficiency standards. The projected impacts of the federal and state appliance and lighting efficiency standards are accounted for in FPL's load forecast as discussed below and in Chapter II. The projected impacts of FPL's DSM efforts are addressed as projected reductions to the forecasted load in Chapters II and III. A discussion of FPL's current DSM programs is presented in Chapter III.

The resource plan that is presented in FPL's 2013 Site Plan contains three key similarities to the resource plan presented in FPL's 2012 Site Plan. However, there are several factors that have contributed to differences between the resource plan presented in the 2013 Site Plan and the resource plan that was previously presented in FPL's 2012 Site Plan. Additional factors will continue to influence FPL's on-going resource planning work and could result in changes in the resource plan presented in this document. A brief discussion of these similarities and factors is provided below. Additional information regarding these topics is presented in Chapter III.

I. Similarities Between the Current Resource Plan and the Resource Plan Previously Presented in FPL's 2012 Site Plan:

There are three key similarities between the current resource plan presented in this document and the resource plan presented in the 2012 Site Plan.

Similarity # 1: The modernizations of FPL's existing Cape Canaveral and Riviera Beach plant sites are underway and are projected to be completed on time in 2013 and 2014, respectively. In addition, the modernization of FPL's existing Port Everglades plant site has begun and it is projected to be completed in 2016.

FPL's 2012 Site Plan projected that the modernizations of two existing sites would be completed in 2013 (Cape Canaveral) and 2014 (Riviera Beach). FPL received need determination approval from the FPSC for both of these modernizations in September 2008 in Order No. PSC-08-0591-FOF-EI. Site Certification was received for Cape Canaveral in October 2009 in Order No. DEP 09-1015. Site Certification was received for Riviera Beach in November 2009 in Order No. DEP 09-1245. The work to complete these modernizations is underway and is proceeding as scheduled. These modernizations are again reflected in this Site Plan with no changes to the projected completion dates. In addition, work regarding a similar modernization at the existing Port Everglades site has begun and the project is projected to be completed in 2016. FPL received need determination approval from the FPSC for the Port Everglades modernization in April 2012 in Order No. PSC-12-0187-FOF-EI. The Site Certification order for the project, DOAH Case No. 12-0422EPP, was received for the Port Everglades project in October 2012.

Similarity # 2: FPL continues to pursue additional nuclear energy generation to significantly (i) reduce its use of fossil fuels, (ii) lower system fuel costs, (iii) lower system air emissions, and (iv) provide a valuable hedge against future increases in fuel costs and environmental compliance costs.

By the date this 2013 Site Plan is filed (April 1, 2013), FPL is projected to have completed essentially all of the work necessary to increase the generation capacity at the fourth of its four existing nuclear generating units, Turkey Point Unit 4. Similar work to increase the generation capacity at FPL's three other nuclear units, St. Lucie Units 1 & 2, and Turkey Point Unit 3 was completed in 2012 and FPL's customers are already benefitting from completion of that work. The total project, called the Extended Power Uprate (EPU) project, will have increased FPL's total nuclear generating capacity by over 500 MW, the equivalent of approximately one-half of a new nuclear unit. The addition of this nuclear generation capacity was accomplished in less than half the time that would be needed to license and construct a new nuclear unit.

In addition, FPL is continuing its work to obtain all of the licenses, permits, and approvals that will be necessary to construct and operate two new nuclear units at its Turkey Point site in the future. These licenses, permits, and approvals will provide FPL with the opportunity to construct these nuclear units at Turkey Point for a time expected to be up to 20 years from the time the licenses and permits are granted, and then to operate the units for at least 40 years thereafter. FPL received need determination approval from the FPSC for the two new nuclear units, Turkey Point Units 6 & 7, in April 2008 in Order No. PSC-08-0237-FOF-EI. The earliest practical deployment dates for these two new units are currently projected to be 2022 and 2023, respectively. Because 2022 is the last year of the 10-year reporting window for this Site Plan, Turkey Point Unit 6 is

addressed in this document (while Turkey Point Unit 7, due to its projected in-service date of 2023, is not addressed in this document).

Similarity # 3: Five generating units were retired in 2012, two other generating units are scheduled to be retired in 2013, and two other generating units have been/will be switched to operate as synchronous condensers.

FPL's 2012 Site Plan discussed FPL's plans to retire specific generation units and to convert other generation units to synchronous condenser operation. Sanford Unit 3, Cutler Unit 5, Cutler Unit 6, and Port Everglades Units 1 & 2 were retired in the fourth quarter of 2012. Two other generating units, Port Everglades Units 3 & 4, are scheduled to be retired in 2013 as part of the Port Everglades Modernization project which will be completed in 2016. In addition, Turkey Point Unit 2 has been converted to operate in synchronous condenser mode to provide voltage support for the transmission system in Southeastern Florida. FPL also projects that Turkey Point Unit 1 will be similarly converted to run in synchronous condenser mode starting in 2016.

II. Factors Influencing FPL's Resource Planning Work Which Have Impacted, or Which Could Impact, FPL's Resource Plan:

There are a number of factors that influence FPL's resource planning work. Eight (8) of these are briefly discussed below and are discussed again in Chapter III.

Two of these factors are on-going system concerns that FPL has considered in its resource planning work for a number of years. These two on-going system concerns are: (1) maintaining/enhancing fuel diversity in the FPL system, and (2) maintaining a balance between load and generating capacity in Southeastern Florida, particularly in Miami-Dade and Broward Counties.

The third and fourth factors that will be discussed are factors that directly impacted the resource plan presented in this document because they affect FPL's forecast of its future load. The third factor is the projection that FPL will begin serving Vero Beach's electrical load beginning January 1, 2014. An agreement to this effect was reached between Vero Beach and FPL on February 19, 2013, and a referendum was held on March 12, 2013 that resulted in a majority of Vero Beach voters approving the agreement.

The fourth factor is an updated projection of the impact of mandated efficiency standards for appliances, lighting, and other electrical equipment. This updated projection of the impact of

these efficiency standards has been incorporated into FPL's load forecast. The magnitude of efficiency that is being delivered to FPL's customers through these standards is significant. For example, by the year 2022, FPL's Summer peak is projected to be lower by approximately 2,900 MW compared to what the projected load would have been without the efficiency standards. This represents a decrease of approximately 10% in the forecasted Summer peak load for 2022. Likewise, FPL's forecasted net energy for load (NEL) in the year 2022 is projected to be approximately 11,850 GWh lower compared to what the projected NEL would have been without the efficiency standards. This represents a decrease of approximately 8% in the forecasted NEL for 2022. These significant reductions in FPL's peak load and NEL have been achieved solely through mandated efficiency standards and have been incremental to the reductions FPL has achieved through its DSM programs.

In addition to lowering FPL's forecast from what it otherwise would have been, and thus lowering FPL's projected resource needs, this projection of increased efficiency from the efficiency standards also affects FPL's resource planning in another way. The mandated higher efficiency standards lower the potential for future MW and GWh reductions from FPL's DSM programs that address the specific appliances and equipment covered by the standards.

The fifth factor is FPL's projected increasing dependence upon DSM resources to maintain system reliability. This factor has been previously discussed in FPL's 2011 and 2012 Site Plans, and it is discussed again in this 2013 Site Plan. In these previous Site Plans, FPL has discussed this projection of increasing dependence upon DSM resources using a new type of reserve margin projection as an indicator: a "generation-only reserve margin" (gen-only RM). In calculating the values for this indicator, all of FPL's projected incremental load management and energy efficiency program capabilities, and its existing load management capability, are removed from the reserve margin calculation. The resulting gen-only RM values indicate what FPL's reserve margin values are projected to be based solely on generation resources. The lower the gen-only RM values, the greater FPL's dependence is upon DSM resources.

The gen-only RM projections from the 2011, 2012, and 2013 Site Plans consistently show that these values are projected to significantly decrease throughout the 10-year reporting period of the Site Plans, and decline to single-digit values in the latter years of the reporting periods. These projections indicate a steadily growing dependence on DSM resources to maintain system reliability. Because of the various voluntary aspects associated with customer participation in DSM programs, FPL believes that system reliability risk increases as dependence on DSM resources increases.

There are additional factors that did not impact the resource plan presented in this document, but which could result in future changes to this resource plan. For example, a sixth factor is the timing of when the Nuclear Regulatory Commission (NRC) will issue a new schedule for its review of FPL's application for a Combined Operating License (COL) for the Turkey Point Units 6 & 7 nuclear units and the potential impact that schedule may have on the overall project schedule. FPL must obtain a COL from the NRC before it could proceed with construction of the two new nuclear units planned for the Turkey Point site. During 2012, the NRC placed several review schedules "under review", including FPL's COL application. At the time this Site Plan is being finalized, the NRC has not identified a date by which it will issue a new schedule. Once the NRC's new review schedule is issued, FPL will conduct a project schedule review, integrating this information with other relevant information, to determine the earliest practicable in-service date for Turkey Point Unit 6 (and Unit 7).

The seventh factor is environmental regulation. As developments occur in regard to either new environmental regulations, and/or in how environmental regulations are interpreted and applied, the potential exists for such developments to affect FPL's resource plan that is presented in this document. For example, FPL has become aware of potential impacts to generating units of recent EPA changes to the National Ambient Air Quality Standards that include shorter duration 1-hour standards for nitrogen dioxide (NO₂) and sulfur dioxide (SO₂). FPL has begun the process of evaluating the impact of these standards on the fossil generating fleet, especially the higher emitting peaking gas turbines that have short emission stacks. The results of this analysis could potentially change FPL's resource plan information that is presented in this document.

The eighth factor that will be discussed is the possibility of the establishment of a Florida standard for renewable energy or clean energy. A Renewable Portfolio Standard (RPS) proposal was prepared by the FPSC, and then sent to the Florida Legislature for consideration, with a possible change to a Clean Portfolio Standard (CPS), during the 2009 legislative session. However, no RPS or CPS legislation was enacted in that session or in subsequent legislative sessions. Furthermore, during the 2012 legislative session, the legislature deleted a now obsolete directive to the FPSC that had instructed them to adopt RPS rules. RPS or CPS legislation, or other legislative initiatives regarding renewable or clean energy contributions, may still occur in the future at either the state or national level. If such legislation is enacted in later years, FPL would then determine what steps need to be taken to address the legislation. Such steps would then be discussed in FPL's Site Plan in the year following the enactment of such legislation.

Each of these factors will continue to be examined in FPL's on-going resource planning work during the rest of 2013 and in future years.

Table ES-1 presents a current projection of major changes to specific generating units and firm capacity purchases for 2013 – 2022 in terms of Summer MW. Table ES-2 then expands upon the information presented in Table ES-1 by adding projections of Winter MW impacts, Summer reserve margins, Winter reserve margins, etc. (Although neither table specifically identifies the impacts of projected DSM additions on FPL’s resource needs and resource plan, FPL’s projected DSM additions have been fully accounted for in the resource plan presented in this Site Plan.)

Table ES-1: Projected Capacity & Firm Purchase Power Changes

Year *	Projected Capacity & Firm Purchase Power Changes	Summer MW	Date
2013	Changes to existing purchases	(425)	December-12
	Port Everglades Units 3 & 4 retired for Modernization	(761)	January-13
	Turkey Point Unit 2 synchronous condenser	(392)	January-13
	Sanford Unit 5 CT Upgrade	9	February-13
	Turkey Point Unit 4 Uprate - completed	115	March-13
	Sanford Unit 4 CT Upgrade	16	April-13
	Martin Unit 1 ESP - Outage	(826)	June-13
	Cape Canaveral Next Generation Clean Energy Center	1,210	June-13
	Total of MW changes to Summer firm capacity:	(1,054)	
2014	Sanford Unit 5 CT Upgrade	10	September-13
	Changes to existing purchases	37	December-13
	Vero Beach Combined Cycle ^{1/}	44	January-14
	Martin Unit 1 ESP - Outage	826	March-14
	Martin Unit 2 ESP - Outage	(826)	March-14
	Manatee Unit 3 CT Upgrade	19	May-14
	Turkey Point Unit 5 CT Upgrade	33	June-14
	Riviera Beach Next Generation Clean Energy Center	1,212	June-14
	Total of MW changes to Summer firm capacity:	1,355	
2015	Manatee Unit 3 CT Upgrade	20	September-14
	Martin Unit 2 ESP - Outage	826	December-14
	Palm Beach SWA - additional capacity	70	January-15
	Fort Myers Unit 2 CT Upgrades	51	May-15
	Total of MW changes to Summer firm capacity:	967	
2016	UPS Replacement	(928)	December-15
	Port Everglades Next Generation Clean Energy Center	1,277	June-16
	Total of MW changes to Summer firm capacity:	349	
2017	Vero Beach Combined Cycle ^{1/}	(44)	January-17
	Changes to existing purchases	(37)	January-17
	Turkey Point Unit 1 synchronous condenser	(396)	October-16
	Total of MW changes to Summer firm capacity:	(477)	
2018	SJRPP suspension of energy	(381)	November-17
	Total of MW changes to Summer firm capacity:	(381)	
2019	---	---	
	Total of MW changes to Summer firm capacity:	0	
2020	---	---	
	Total of MW changes to Summer firm capacity:	0	
2021	Eco-Gen PPA	180	January-21
	Total of MW changes to Summer firm capacity:	180	
2022	Turkey Point Nuclear Unit 6	1,100	June-22
	Total of MW changes to Summer firm capacity:	1,100	

* Year shown reflects when the MW change begins to be accounted for in Summer reserve margin calculations. (Note that addition of MW values for each year will not yield a current cumulative value.)

1/ This unit will be added as part of the agreement that FPL will serve Vero Beach's electric load starting January, 2014. This unit is expected to be retired within 3 years.

Table ES-2: Projected Capacity Changes and Reserve Margins for FPL

Projected Capacity Changes and Reserve Margins for FPL ⁽¹⁾					
Year	Projected Capacity Changes	Net Capacity Changes (MW)		Reserve Margin (%) After Maintenance	
		Winter ⁽²⁾	Summer ⁽³⁾	Winter	Summer
2013	Changes to Existing Purchases ⁽⁴⁾	(545)	(425)		
	Port Everglades Units 3 & 4 retired for Modernization	(765)	(761)		
	Turkey Point Unit 2 operation changed to synchronous condenser	(394)	(392)		
	Sanford Unit 5 CT Upgrade	---	9		
	Turkey Point Unit 4 Uprate - Completed	---	115		
	Turkey Point Unit 4 Uprate - Outage ⁽⁵⁾	(717)	---		
	Sanford Unit 4 CT Upgrade	---	16		
	Manatee Unit 2	(3)	---		
	Scherer Unit 4	(28)	---		
	Cape Canaveral Next Generation Clean Energy Center ⁽⁶⁾	---	1,210		
	Manatee Unit 1 ESP - Outage ⁽⁷⁾	(822)	---		
Martin Unit 1 ESP - Outage ⁽⁷⁾	---	(826)	30.6%	28.0%	
2014	Sanford Unit 5 CT Upgrade	19	10		
	Cape Canaveral Next Generation Clean Energy Center ⁽⁶⁾	1,355	---		
	Changes to Existing Purchases ⁽⁴⁾	22	37		
	Manatee Unit 1 ESP - Outage ⁽⁷⁾	822	---		
	Sanford Unit 4 CT Upgrade	16	---		
	Vero Beach Combined Cycle ⁽⁸⁾	46	44		
	Martin Unit 1 ESP - Outage ⁽⁷⁾	(832)	826		
	Martin Unit 2 ESP - Outage ⁽⁷⁾	---	(826)		
	Manatee Unit 3 CT Upgrade	---	19		
	Turkey Point Unit 5 CT Upgrade	---	33		
	Turkey Point Unit 4 Uprate - Completed ⁽⁵⁾	115	---		
Riviera Beach Next Generation Clean Energy Center ⁽⁶⁾	---	1,212	34.1%	28.5%	
2015	Manatee Unit 3 CT Upgrade	39	20		
	Martin Unit 1 ESP - Outage ⁽⁷⁾	832	---		
	Martin Unit 2 ESP - Outage ⁽⁷⁾	---	826		
	Turkey Point Unit 5 CT Upgrade	33	---		
	Changes to Existing Purchases ⁽⁴⁾	70	70		
	Ft. Myers Unit 2 CT Upgrade	---	51		
	Riviera Beach Next Generation Clean Energy Center ⁽⁶⁾	1,344	---	42.2%	31.2%
2016	Changes to Existing Purchases ⁽⁴⁾	(858)	(928)		
	Ft. Myers Unit 2 CT Upgrade	51	---		
	Port Everglades Next Generation Clean Energy Center ⁽⁶⁾	---	1,277	36.5%	31.3%
2017	Turkey Point Unit 1 operation changed to synchronous condenser	(398)	(396)		
	Changes to Existing Purchases ⁽⁴⁾	(37)	(37)		
	Vero Beach Combined Cycle ⁽⁸⁾	(46)	(44)		
	Port Everglades Next Generation Clean Energy Center ⁽⁶⁾	1,429	---	40.0%	27.5%
2018	Changes to Existing Purchases ⁽⁴⁾	(388)	(381)	37.0%	24.3%
2019	---	---	36.0%	22.7%	
2020	---	---	34.9%	21.1%	
2021	Changes to Existing Purchases ⁽⁴⁾	180	180	34.5%	21.0%
2022	Turkey Point Nuclear Unit 6 ⁽⁶⁾	---	1,100	34.4%	23.5%

(1) Additional information about these resulting reserve margins and capacity changes are found on Schedules 7 & 8 respectively.
(2) Winter values are forecasted values for January of the year shown.
(3) Summer values are forecasted values for August of the year shown.
(4) These are firm capacity and energy contracts with QF, utilities, and other entities. See Table I.B.1 and Table I.B.2 for more details.
(5) Outages for uprate work.
(6) All new unit additions are scheduled to be in-service in June of the year shown. All additions assumed to start in June are included in the Summer reserve margin calculation starting in that year and in the Winter reserve margin calculation starting with the next year.
(7) Outages for ESP work.
(8) This unit will be added as part of the agreement that FPL will serve Vero Beach's electric load starting January, 2014. This unit is expected to be retired within 3 years.

CHAPTER I

Description of Existing Resources

(This page is left intentionally blank.)

I. Description of Existing Resources

FPL's service area contains approximately 27,650 square miles and has a population of approximately 8.9 million people. FPL served an average of 4,576,449 customer accounts in thirty-five counties during 2012. These customers were served by a variety of resources including: FPL-owned fossil-fueled, renewable, and nuclear generating units, non-utility owned generation, demand side management (DSM), and interchange/purchased power.

I.A. FPL-Owned Resources

The existing FPL generating resources are located at fourteen generating sites distributed geographically around its service territory, plus one site in Georgia (partial FPL ownership of one unit) and one site in Jacksonville, Florida (partial FPL ownership of two units). The current electrical generating facilities consist of four nuclear units, three coal units, fifteen combined cycle (CC) units, eight fossil steam units, forty-eight combustion gas turbines, two simple cycle combustion turbines, and two photovoltaic facilities¹. The locations of these eighty-two generating units are shown on Figure I.A.1 and in Table I.A.1. Table I.A.2 provides a further "break down" of the capacity provided by the combustion turbine (CT) and steam turbine (ST) components of FPL's existing CC units.

FPL's bulk transmission system is comprised of 6,558 circuit miles of transmission lines. Integration of the generation, transmission, and distribution system is achieved through FPL's 591 substations in Florida.

The existing FPL system, including generating plants, major transmission stations, and transmission lines, is shown on Figure I.A.2. In addition, Figure I.A.3 shows FPL's interconnection ties with other utilities.

¹ FPL also has one 75 MW solar thermal facility at its Martin plant site. This facility does not generate electricity as the other units mentioned above do. Instead, it produces steam that reduces the use of fossil fuel to produce steam for electricity generation.

FPL Generating Resources by Location

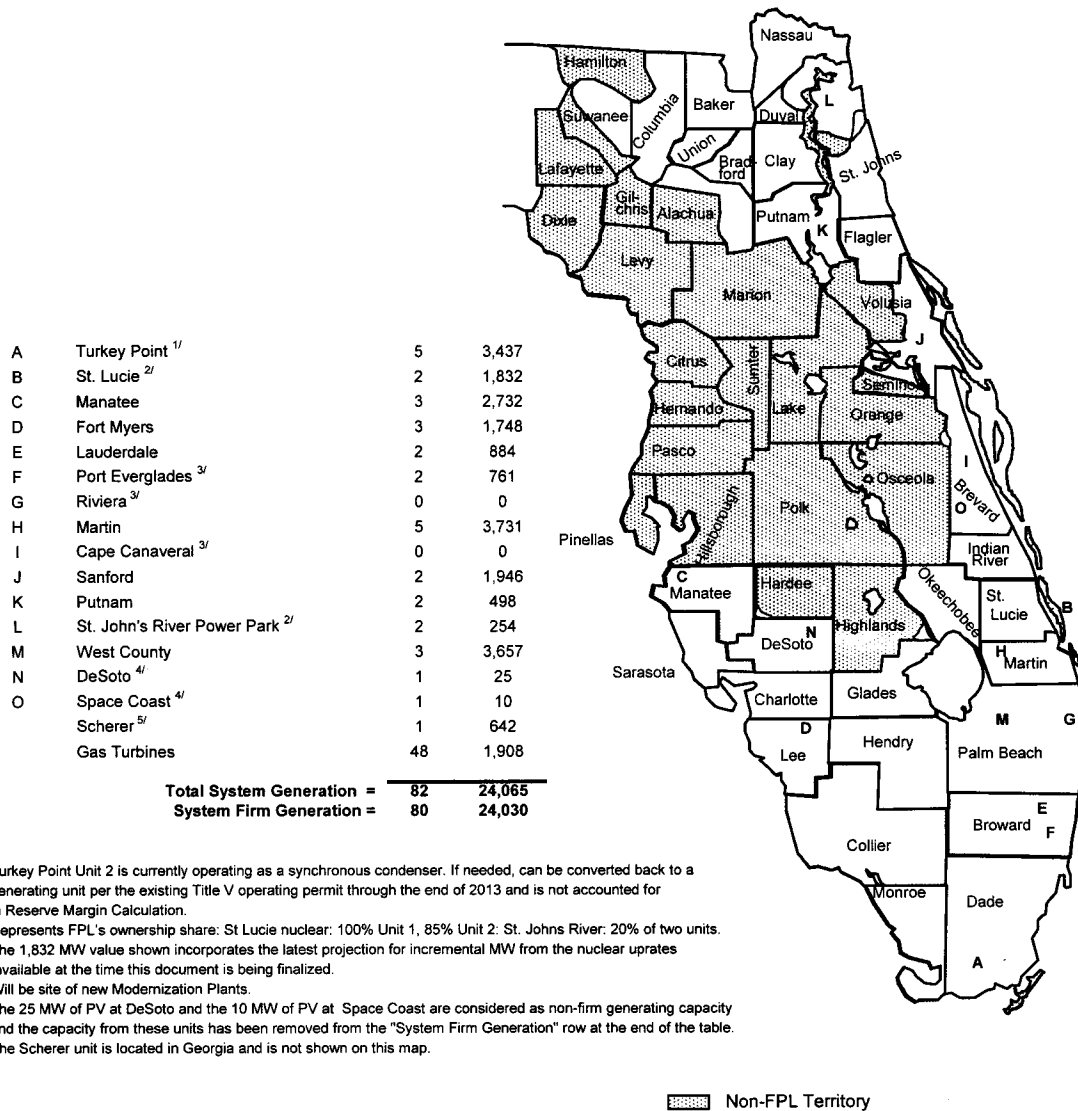

Figure I.A.1: Capacity Resources by Location (as of December 31, 2012)

Table I.A.1: Capacity Resource by Unit Type (as of December 31, 2012)

<u>Unit Type/ Plant Name</u>	<u>Location</u>	<u>Number of Units</u>	<u>Fuel</u>	<u>Summer MW</u>
<u>Nuclear</u>				
St. Lucie ^{1/}	Hutchinson Island, FL	2	Nuclear	1,832
Turkey Point	Florida City, FL	2	Nuclear	1,501
Total Nuclear:		4		3,333
<u>Coal Steam</u>				
Scherer	Monroe County, Ga	1	Coal	642
St. John's River Power Park ^{2/}	Jacksonville, FL	2	Coal	254
Total Coal Steam:		3		896
<u>Combined-Cycle ^{3/}</u>				
Fort Myers	Fort Myers, FL	1	Gas	1,432
Manatee	Parrish, FL	1	Gas	1,111
Martin	Indiantown, FL	3	Gas	2,079
Sanford	Lake Monroe, FL	2	Gas	1,946
Lauderdale	Dania, FL	2	Gas/Oil	884
Putnam	Palatka, FL	2	Gas/Oil	498
Turkey Point	Florida City, FL	1	Gas/Oil	1,148
West County	Palm Beach County, FL	3	Gas/Oil	3,657
Total Combined Cycle:		15		12,755
<u>Oil/Gas Steam</u>				
Manatee	Parrish, FL	2	Oil/Gas	1,621
Martin	Indiantown, FL	2	Oil/Gas	1,652
Port Everglades	Port Everglades, FL	2	Oil/Gas	761
Turkey Point ^{4/}	Florida City, FL	2	Oil/Gas	788
Total Oil/Gas Steam:		8		4,822
<u>Gas Turbines(GT)</u>				
Fort Myers (GT)	Fort Myers, FL	12	Oil	648
Lauderdale (GT)	Dania, FL	24	Gas/Oil	840
Port Everglades (GT)	Port Everglades, FL	12	Gas/Oil	420
Total Gas Turbines/Diesels:		48		1,908
<u>Combustion Turbines ^{3/}</u>				
Fort Myers	Fort Myers, FL	2	Gas/Oil	316
Total Combustion Turbines:		2		316
<u>PV</u>				
DeSoto ^{5/}	DeSoto, FL	1	Solar Energy	25
Space Coast ^{5/}	Brevard County, FL	1	Solar Energy	10
Total PV:		2		35
Total System Generation as of December 31, 2012 =		82		24,065
System Firm Generation as of December 31, 2012 =		80		24,030

1/ Total capability of St. Lucie 1 is 981/1,003 MW. FPL's share of St. Lucie 2 is 843/862. FPL's ownership share of St. Lucie Units 1 and 2 is 100% and 85%, respectively.

2/ Capabilities shown represent FPL's output share from each of the units (approx. 92.5% and exclude the Orlando Utilities Commission (OUC) and Florida Municipal Power Agency (FMPA) combined portion of approximately 7.44776% per unit. Represents FPL's ownership share: SJRPP coal: 20% of two units).

3/ The Combined Cycles and Combustion Turbines are broken down by components on Table 1.A.2.

4/ Turkey Point 2 is currently operating as a synchronous condenser. If needed, can be converted back to a generating unit per the existing Title V operating permit through the end of 2013 and is not accounted for in Reserve Margin Calculation.

5/ The 25 MW of PV at DeSoto and the 10 MW of PV at Space Coast are considered as non-firm generating capacity and the capacity from these units has been removed from the "System Firm Generation" row at the end of the table.

Table I.A.2: Combined Cycle and Combustion Turbine Components

		Summer MW *									
Combined-Cycle	Plant Name/ Unit No.	CT	CT	CT	CT	CT	CT	Steam	Steam	BOP	Total Unit
		A	B	C	D	E	F	1	2	Aux	MW
	Ft Myers 2	159	159	159	159	159	159	60	437	(20)	1,432
	Lauderdale 4	158	158	---	---	---	---	131	---	(5)	442
	Lauderdale 5	158	158	---	---	---	---	131	---	(5)	442
	Manatee 3	167	167	167	167	---	---	458	---	(17)	1,109
	Martin 3	166	166	---	---	---	---	144	---	(6)	469
	Martin 4	166	166	---	---	---	---	144	---	(6)	469
	Martin 8	173	173	173	173	---	---	474	---	(23)	1,142
	Putnam 1	71	71	---	---	---	---	112	---	(5)	249
	Putnam 2	71	71	---	---	---	---	112	---	(5)	249
	Sanford 4	163	163	163	163	---	---	333	---	(12)	973
	Sanford 5	163	163	163	163	---	---	336	---	(13)	975
	Turkey Point 5	174	174	174	174	---	---	478	---	(26)	1,149
	West County 1	248	248	248	---	---	---	499	---	(25)	1,219
	West County 2	248	248	248	---	---	---	499	---	(25)	1,219
	West County 3	248	248	248	---	---	---	499	---	(25)	1,219

Combustion Turbines		CT	CT	CT	CT	CT	CT	CT	CT	BOP	Total Unit
		A	B	C	D	E	F	1	2	Aux	MW
	Ft. Myers 3A	158	---	---	---	---	---	---	---	(1)	157
	Ft. Myers 3B	---	158	---	---	---	---	---	---	(1)	157

This table shows the breakdown of total MW for each unit by CT and steam component.

* The total MW values shown in this table may differ slightly from values shown in other tables due to rounding of per-component values.

Table 1.A.3: Purchase Power Resources by Contract (as of December 31, 2012)

Table 1.A.3: Purchase Power Resources by Contract (as of December 31, 2012)

	Location (City or County)	Fuel	Summer MW
<u>I. Purchases from QF's: Cogeneration/Small Power Production Facilities</u>			
Cedar Bay Generating Co.	Duval	Coal (Cogen)	250
Indiantown Cogen., LP	Martin	Coal (Cogen)	330
Broward South	Broward	Solid Waste	4
Broward North	Broward	Solid Waste	11
Palm Beach SWA - extension			40
		Total:	635
<u>II. Purchases from Utilities:</u>			
UPS from Southern Company	Various in Georgia	Coal	928
SJRPP	Jacksonville, FL	Coal	381
TECO	Tampa	Coal	125
		Total:	1,434
<u>III. Other Purchases:</u>			
DeSoto Unit 1	DeSoto	Natural Gas	150
DeSoto Unit 2	DeSoto	Natural Gas	155
			305
		Total Net Firm Generating Capability:	2,374

<u>Non-Firm Energy Purchases (MWH)</u>			
Project	County	Fuel	Energy (MWH) Delivered to FPL in 2012
Okeelanta (known as Florida Crystals and New Hope Power Partners) *	Palm Beach	Bagasse/Wood	141,594
Broward South *	Broward	Solid Waste	127,533
Broward North *	Broward	Solid Waste	119,168
Tomoka Farms *	Volusia	Landfill Gas	0
Waste Management - Renewable Energy *	Broward	Landfill Gas	45,371
Waste Management - Collier County Landfill *	Broward	Landfill Gas	29,303
Tropicana	Manatee	Natural Gas	22,935
Calnetix	Palm Beach	Natural Gas	0
Georgia Pacific	Putnam	Paper by-product	9,550
Rothenbach Park (known as MMA Bee Ridge)	Sarasota	PV	320
First Solar	Miami	PV	67
Customer - Owned PV & Wind	Various	PV/Wind	877
Palm Beach SWA	Palm Beach	Solid Waste	370,109
INEOS Bio *	Indian River	Wood	70

* These Non-Firm Energy Purchases are Renewable and are reflected on Schedule 11.1 row 9 column 6.

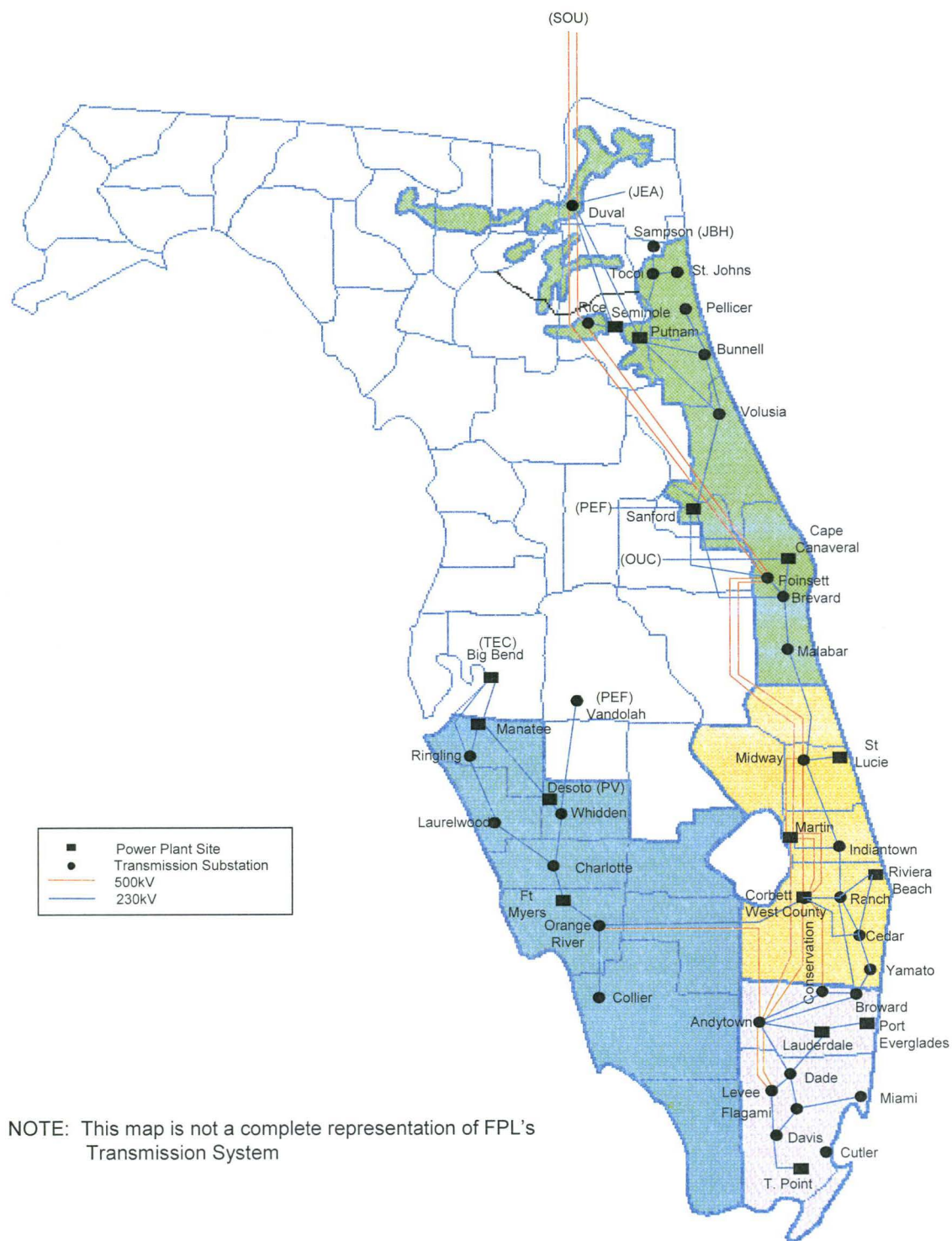
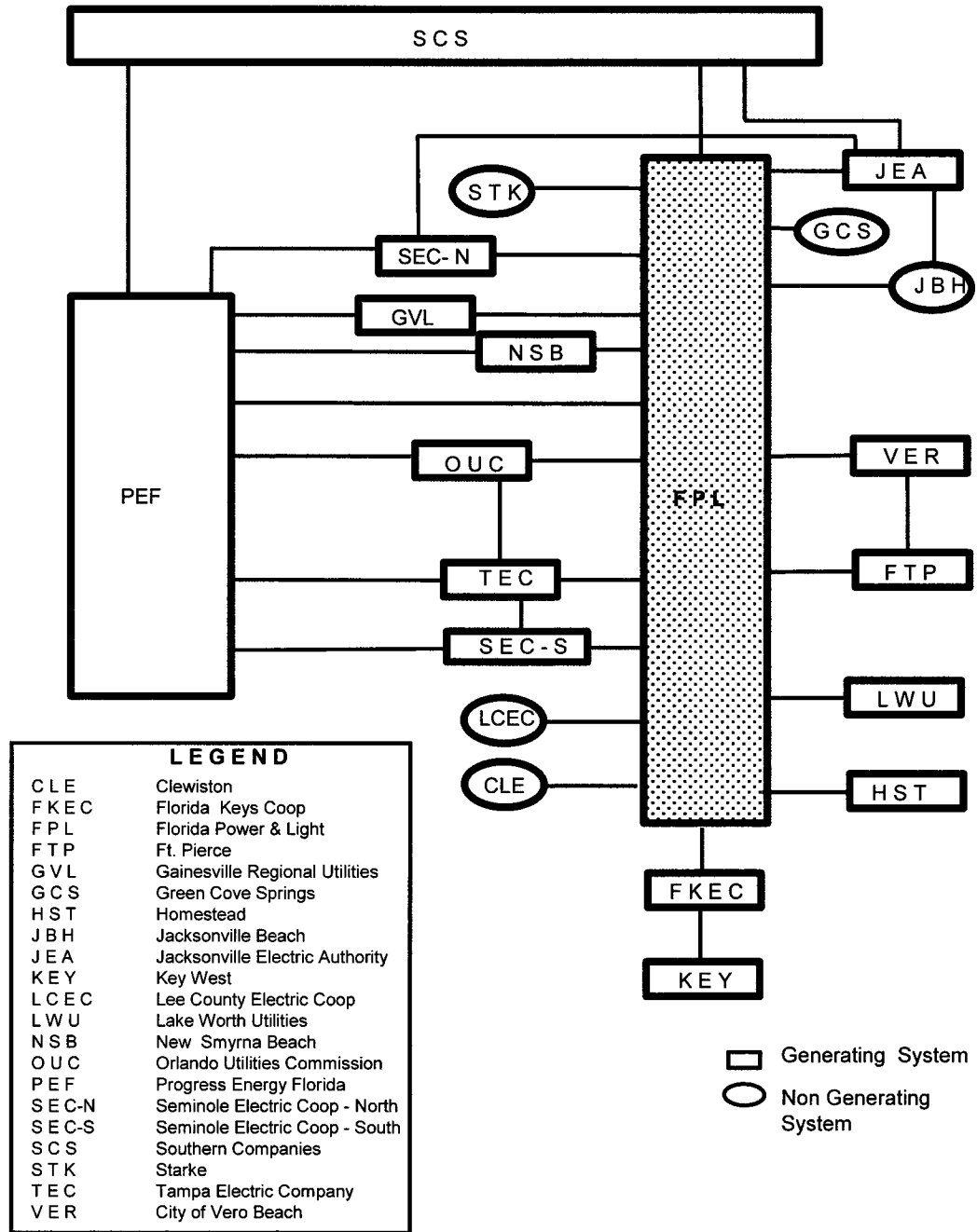

Figure I.A.2: FPL Substation and Transmission System Configuration

FPL Interconnection Diagram



LEGEND	
CLE	Clewiston
FKEC	Florida Keys Coop
FPL	Florida Power & Light
FTP	Ft. Pierce
GVL	Gainesville Regional Utilities
GCS	Green Cove Springs
HST	Homestead
JBH	Jacksonville Beach
JEA	Jacksonville Electric Authority
KEY	Key West
LCEC	Lee County Electric Coop
LWU	Lake Worth Utilities
NSB	New Smyrna Beach
OUC	Orlando Utilities Commission
PEF	Progress Energy Florida
SEC-N	Seminole Electric Coop - North
SEC-S	Seminole Electric Coop - South
SCS	Southern Companies
STK	Starke
TEC	Tampa Electric Company
VER	City of Vero Beach

Generating System
 Non Generating System

Figure I.A.3: FPL Interconnection Diagram

Description of Existing Resources

I.B Firm Capacity Power Purchases

Purchases from Qualifying Facilities (QF):

Firm capacity power purchases are an important part of FPL's resource mix. FPL currently has contracts with eight qualifying facilities; i.e., cogeneration/small power production facilities, to purchase firm capacity and energy during the 10-year reporting period of this Site Plan as shown in Table I.A.3, Table I.B.1, and Table I.B.2.

A cogeneration facility is one which simultaneously produces electrical and thermal energy, with the thermal energy (e.g., steam) being used for industrial, commercial, or cooling and heating purposes. A small power production facility is one which does not exceed 80 MW (unless it is exempted from this size limitation by the Solar, Wind, Waste, and Geothermal Power Production Incentives Act of 1990) and uses as its primary energy source solar, wind, waste, geothermal, or other renewable resources.

Purchases from Utilities:

FPL has a Unit Power Sales (UPS) contract to purchase 928 MW from the Southern Company (Southern) through the end of December 2015. This capacity is being supplied by Southern from a mix of gas-fired and coal-fired units.

In addition, FPL has contracts with the Jacksonville Electric Authority (JEA) for the purchase of 381 MW (Summer) and 388 MW (Winter) of coal-fired generation from the St. John's River Power Park (SJRPP) Units No. 1 and No. 2. However, due to Internal Revenue Service (IRS) regulations, the total amount of energy that FPL may receive from this purchase is limited. FPL currently assumes, for planning purposes, that this limit will be reached in November of 2017. Once this limit is reached, FPL will be unable to receive firm capacity and energy from these purchases. (However, FPL will continue to receive firm capacity and energy from its ownership portion of the SJRPP units.)

As part of the agreement that FPL will begin serving Vero Beach's electrical needs beginning in January 2014, FPL has acquired two existing power purchase agreements totaling approximately 37 MW of coal-fired capacity. These agreements will run through the end of 2016.

These purchases are shown in Table I.A.3, Table I.B.1, and Table I.B.2. FPL also has ownership interest in the SJRPP units. The ownership amount is reflected in FPL's installed capacity shown on Figure I.A.1, in Table I.A.1, and on Schedule 1.

Other Purchases:

FPL has two other firm capacity purchase contracts with non-QF, non-utility suppliers. These contracts with the Palm Beach Solid Waste Authority were previously listed as QFs; however, the addition of a second unit will cause both units to no longer meet the statutory definition of a QF. These contracts are therefore listed as "Other Purchases" after the current estimated in-service date of the new unit. Table I.B.1 and I.B.2 present the Summer and Winter MW, respectively, resulting from these contracts under the category heading of Other Purchases.

Table I.B.1: FPL's Firm Purchased Power Summer MW

Summary of FPL's Firm Capacity Purchases: Summer MW (for August of Year Shown)

I. Purchases from QF's:

Cogeneration Small Power Production Facilities	Contract Start Date	Contract End Date	2013	2014	2015	2016	2017	2018	2019	2020	2021	2022
			Broward South	01/01/93	12/31/26	1.4	1.4	1.4	1.4	1.4	1.4	1.4
Broward South	01/01/95	12/31/26	1.5	1.5	1.5	1.5	1.5	1.5	1.5	1.5	1.5	1.5
Broward South	01/01/97	12/31/26	0.6	0.6	0.6	0.6	0.6	0.6	0.6	0.6	0.6	0.6
Broward North	01/01/93	12/31/26	7	7	7	7	7	7	7	7	7	7
Broward North	01/01/95	12/31/26	1.5	1.5	1.5	1.5	1.5	1.5	1.5	1.5	1.5	1.5
Broward North	01/01/97	12/31/26	2.5	2.5	2.5	2.5	2.5	2.5	2.5	2.5	2.5	2.5
Cedar Bay Generating Co.	01/25/94	12/31/24	250	250	250	250	250	250	250	250	250	250
Indiantown Cogen., LP	12/22/95	12/01/25	330	330	330	330	330	330	330	330	330	330
Palm Beach SWA -extension ^{1/}	01/01/12	04/01/32	40	40	0	0	0	0	0	0	0	0
U.S. EcoGen - Clay ^{2/}	01/01/21	12/31/49	0	0	0	0	0	0	0	0	60	60
U.S. EcoGen -Okeechobee ^{2/}	01/01/21	12/31/49	0	0	0	0	0	0	0	0	60	60
U.S. EcoGen - Martin ^{2/}	01/01/21	12/31/49	0	0	0	0	0	0	0	0	60	60
QF Purchases Sub Total:			635	635	595	595	595	595	595	595	775	775

II. Purchases from Utilities:

	Contract Start Date	Contract End Date	2013	2014	2015	2016	2017	2018	2019	2020	2021	2022
			UPS Replacement	06/01/10	12/31/15	928	928	928	0	0	0	0
SJRPP ^{3/}	04/02/82	11/01/17	381	381	381	381	381	0	0	0	0	0
OUC - Stanton 1 ^{4/}	01/01/14	12/31/16	0	21	21	21	0	0	0	0	0	0
OUC - Stanton 2 ^{4/}	01/01/14	12/31/16	0	16	16	16	0	0	0	0	0	0
Utility Purchases Sub Total:			1,309	1,346	1,346	418	381	0	0	0	0	0

Total of QF and Utility Purchases =	1,944	1,980	1,940	1,012	976	595	595	595	775	775
--	--------------	--------------	--------------	--------------	------------	------------	------------	------------	------------	------------

III. Other Purchases:

	Contract Start Date	Contract End Date	2013	2014	2015	2016	2017	2018	2019	2020	2021	2022
			Palm Beach SWA -extension ^{1/}	01/01/12	04/01/32	0	0	40	40	40	40	40
Palm Beach SWA - additional	01/01/15	04/01/32	0	0	70	70	70	70	70	70	70	70
Other Purchases Sub Total:			0	0	110	110	110	110	110	110	110	110

Total "Non-QF" Purchase =	1,309	1,346	1,456	528	491	110	110	110	110	110
----------------------------------	--------------	--------------	--------------	------------	------------	------------	------------	------------	------------	------------

Summer Firm Capacity Purchases Total MW:	1,944	1,980	2,050	1,122	1,086	705	705	705	885	885
---	--------------	--------------	--------------	--------------	--------------	------------	------------	------------	------------	------------

1/ When the second unit comes into service at the Palm Beach SWA, neither unit will meet the standards to be a small power producers, and both units then will be accounted for under "Other Purchases".

2/ The EcoGen units will enter service in 2019, and initially provide non-firm energy. Firm capacity delivery will commence in 2021.

3/ Contract End Date shown for the SJRPP purchase does not represent the actual contract end date. Instead, this date represents a projection of the earliest date at which FPL's ability to receive further capacity and energy from this purchase could be suspended due to IRS regulations.

4/ These units are part of the purchase of the Vero Beach Electric System.

Table I.B.2: FPL's Firm Purchased Power Winter MW

Summary of FPL's Firm Capacity Purchases: Winter MW (for January of Year Shown)

I. Purchases from QF's:

Cogeneration Small Power Production Facilities	Contract Start Date	Contract End Date	2013	2014	2015	2016	2017	2018	2019	2020	2021	2022
			Broward South	01/01/93	12/31/26	1.4	1.4	1.4	1.4	1.4	1.4	1.4
Broward South	01/01/95	12/31/26	1.5	1.5	1.5	1.5	1.5	1.5	1.5	1.5	1.5	1.5
Broward South	01/01/97	12/31/26	0.6	0.6	0.6	0.6	0.6	0.6	0.6	0.6	0.6	0.6
Broward North	01/01/93	12/31/26	7	7	7	7	7	7	7	7	7	7
Broward North	01/01/95	12/31/26	1.5	1.5	1.5	1.5	1.5	1.5	1.5	1.5	1.5	1.5
Broward North	01/01/97	12/31/26	2.5	2.5	2.5	2.5	2.5	2.5	2.5	2.5	2.5	2.5
Cedar Bay Generating Co.	01/25/94	12/31/24	250	250	250	250	250	250	250	250	250	250
Indiantown Cogen., LP	12/22/95	12/01/25	330	330	330	330	330	330	330	330	330	330
Palm Beach SWA -extension ^{1/}	01/01/12	04/01/32	40	40	0	0	0	0	0	0	0	0
U.S. EcoGen - Clay ^{2/}	01/01/21	12/31/49	0	0	0	0	0	0	0	0	60	60
U.S. EcoGen -Okeechobee ^{2/}	01/01/21	12/31/49	0	0	0	0	0	0	0	0	60	60
U.S. EcoGen - Martin ^{2/}	01/01/21	12/31/49	0	0	0	0	0	0	0	0	60	60
QF Purchases Sub Total:			635	635	595	595	595	595	595	595	775	775

II. Purchases from Utilities:

	Contract Start Date	Contract End Date	2013	2014	2015	2016	2017	2018	2019	2020	2021	2022
			UPS Replacement	06/01/10	12/31/15	928	928	928	0	0	0	0
SJRPP ^{3/}	04/02/82	11/01/17	388	388	388	388	388	0	0	0	0	0
OUC - Stanton 1 ^{4/}	01/01/14	12/31/16	0	21	21	21	0	0	0	0	0	0
OUC - Stanton 2 ^{4/}	01/01/14	12/31/16	0	16	16	16	0	0	0	0	0	0
Utility Purchases Sub Total:			1,316	1,353	1,353	425	388	0	0	0	0	0

Total of QF and Utility Purchases =	1,951	1,987	1,947	1,019	983	595	595	595	775	775
--	--------------	--------------	--------------	--------------	------------	------------	------------	------------	------------	------------

III. Other Purchases:

	Contract Start Date	Contract End Date	2013	2014	2015	2016	2017	2018	2019	2020	2021	2022
			Palm Beach SWA -extension ^{1/}	01/01/12	04/01/32	0	0	40	40	40	40	40
Palm Beach SWA - additional	01/01/15	04/01/32	0	0	70	70	70	70	70	70	70	70
Other Purchases Sub Total:			0	0	110	110	110	110	110	110	110	110

"Non-QF" Purchase =	1,316	1,353	1,463	535	498	110	110	110	110	110
----------------------------	--------------	--------------	--------------	------------	------------	------------	------------	------------	------------	------------

	2013	2014	2015	2016	2017	2018	2019	2020	2021	2022
Winter Firm Capacity Purchases Total MW:	1,951	1,987	2,057	1,129	1,093	705	705	705	885	885

1/ When the second unit comes into service at the Palm Beach SWA, neither unit will meet the standards to be a small power producers, and both units then will be accounted for under "Other Purchases".

2/ The EcoGen units will enter service in 2019, and initially provide non-firm energy. Firm capacity delivery will commence in 2021.

3/ Contract End Date shown for the SJRPP purchase does not represent the actual contract end date. Instead, this date represents a projection of the earliest date at which FPL's ability to receive further capacity and energy from this purchase could be suspended due to IRS regulations.

4/ These units are part of the purchase of the Vero Beach Electric System.

I.C Non-Firm (As Available) Energy Purchases

FPL purchases non-firm (as-available) energy from several cogeneration and small power production facilities. Table I.C.1 shows the amount of energy purchased in 2012 from these facilities.

Table I.C.1: As-Available Energy Purchases from Non-Utility Generators in 2012

Project	County	Fuel	In-Service Date	Energy (MWH) Delivered to 2012
Okeelanta (known as Florida Crystals and New Hope Power Partners) *	Palm Beach	Bagasse/Wood	11/95	141,594
Broward South *	Broward	Solid Waste	9/09	127,533
Broward North *	Broward	Solid Waste	1/12	119,168
Tomoka Farms *	Volusia	Landfill Gas	7/98	0
Waste Management - Renewable Energy *	Broward	Landfill Gas	1/10	45,371
Waste Management - Collier County Landfill *	Broward	Landfill Gas	5/11	29,303
Tropicana	Manatee	Natural Gas	2/90	22,935
Calnetix	Palm Beach	Natural Gas	7/05	0
Georgia Pacific	Putnam	Paper by-product	2/94	9,550
Rothenbach Park (known as MMA Bee Ridge)	Sarasota	PV	10/07	320
First Solar	Miami	PV	4/11	67
Customer - Owned PV & Wind	Various	PV/Wind	Various	877
Palm Beach SWA	Palm Beach	Solid Waste	4/10	370,109
INEOS Bio *	Indian River	Wood	9/12	70

* These Non-Firm Energy Purchases are Renewable and are reflected on Schedule 11.1 row 9 column 6.

I.D Demand Side Management (DSM)

FPL has sought out and implemented cost-effective DSM programs since 1978. These programs include a number of conservation/energy efficiency and load management initiatives. FPL's DSM efforts through 2012 have resulted in a cumulative Summer peak reduction of approximately 4,652 MW at the generator and an estimated cumulative energy saving of approximately 62,653 Gigawatt-hour (GWh) at the generator. After accounting for reserve margin requirements, FPL's DSM efforts through 2012 have eliminated the need to construct the equivalent of approximately 14 new 400 MW generating units. DSM is discussed further in Chapter III.

Schedule 1

**Existing Generating Facilities
As of December 31, 2012**

(1)	(2)	(3)	(4)	(5)	(6)	(7)	(8)	(9)	(10)	(11)	(12)	(13)	(14)
Plant Name	Unit No.	Location	Unit Type	Fuel		Transport		Fuel Days Use	Commercial In-Service Month/Year	Actual/Expected Retirement Month/Year	Gen.Max. Nameplate KW	Net Capability ^{1/}	
				Pri.	Alt.	Pri.	Alt.	Use		Month/Year		Winter MW	Summer MV
DeSoto ^{2/}		DeSoto County 27/36S/25E											
	1		PV	N/A	N/A	N/A	N/A	Unknown	Oct-09	Unknown	27,000	25	25
Fort Myers		Lee County 35/43S/25E									<u>3,198,770</u>	<u>2,552</u>	<u>2,396</u>
	2		CC	NG	No	PL	No	Unknown	Jun-02	Unknown	1,701,890	1,490	1,432
	3A		CT	NG	FO2	PL	TK	Unknown	Jun-03	Unknown	376,380	176	158
	3B		CT	NG	FO2	PL	TK	Unknown	Jun-03	Unknown	376,380	176	158
	1-12		GT	FO2	No	TK	No	Unknown	May-74	Unknown	744,120	710	648
Lauderdale		Broward County 30/50S/42E									<u>1,873,968</u>	<u>1,984</u>	<u>1,724</u>
	4		CC	NG	FO2	PL	PL	Unknown	May-93	Unknown	526,250	483	442
	5		CC	NG	FO2	PL	PL	Unknown	Jun-93	Unknown	526,250	483	442
	1-12		GT	NG	FO2	PL	PL	Unknown	Aug-70	Unknown	410,734	459	420
	13-24		GT	NG	FO2	PL	PL	Unknown	Aug-70	Unknown	410,734	459	420
Manatee		Manatee County 18/33S/20E									<u>2,951,110</u>	<u>2,809</u>	<u>2,732</u>
	1		ST	FO6	NG	WA	PL	Unknown	Oct-76	Unknown	863,300	822	812
	2		ST	FO6	NG	WA	PL	Unknown	Dec-77	Unknown	863,300	819	809
	3		CC	NG	No	PL	No	Unknown	Jun-05	Unknown	1,224,510	1,168	1,111
Martin		Martin County 29/29S/38E									<u>4,317,510</u>	<u>3,870</u>	<u>3,731</u>
	1		ST	FO6	NG	PL	PL	Unknown	Dec-80	Unknown	934,500	832	826
	2		ST	FO6	NG	PL	PL	Unknown	Jun-81	Unknown	934,500	832	826
	3		CC	NG	No	PL	No	Unknown	Feb-94	Unknown	612,000	489	469
	4		CC	NG	No	PL	No	Unknown	Apr-94	Unknown	612,000	489	469
	8 ^{3/}		CC	NG	FO2	PL	TK	Unknown	Jun-05	Unknown	1,224,510	1,228	1,141
Port Everglades		City of Hollywood 23/50S/42E									<u>1,214,834</u>	<u>1,224</u>	<u>1,181</u>
	3		ST	FO6	NG	WA	PL	Unknown	Jul-64	Jan-13	402,050	389	387
	4		ST	FO6	NG	WA	PL	Unknown	Apr-65	Jan-13	402,050	376	374
	1-12		GT	NG	FO2	PL	PL	Unknown	Aug-71	Unknown	410,734	459	420
Putnam		Putnam County 16/10S/27E									<u>580,008</u>	<u>530</u>	<u>498</u>
	1		CC	NG	FO2	PL	TK	Unknown	Apr-78	Unknown	290,004	265	249
	2		CC	NG	FO2	PL	TK	Unknown	Aug-77	Unknown	290,004	265	249

1/ These ratings are peak capability.

2/ The capacity shown for the PV facility at DeSoto is considered as non-firm generating capacity and the capacity from these units has been removed from the "System Firm Generating Capacity as of December 31, 2012" row at the end of the table.

3/ Martin Unit 8 is also partially fueled by a 75 MW solar thermal facility that supplies steam when adequate sunlight is available, thus reducing fossil fuel use.

Schedule 1

Existing Generating Facilities
As of December 31, 2012

(1)	(2)	(3)	(4)	(5)	(6)	(7)	(8)	(9)	(10)	(11)	(12)	(13)	(14)
Plant Name	Unit No.	Location	Unit Type	Fuel		Transport		Fuel Days Use	Commercial In-Service Month/Year	Actual/Expected Retirement Month/Year	Gen. Max. Nameplate KW	Net Capability ^{1/}	
				Pri.	Alt.	Pri.	Alt.					Winter MW	Summer MW
Sanford		Volusia County 16/19S/30E									<u>2,377,720</u>	<u>2,125</u>	<u>1,946</u>
	4		CC	NG	No	PL	No	Unknown	Oct-03	Unknown	1,188,860	1,062	973
	5		CC	NG	No	PL	No	Unknown	Jun-02	Unknown	1,188,860	1,063	973
Scherer ^{2/}	4	Monroe, GA	ST	SUB	No	RR	No	Unknown	Jul-89	Unknown	<u>680,368</u>	<u>651</u>	<u>642</u>
											680,368	651	642
Space Coast ^{3/}	1	Brevard County 13/23S/36E	PV	N/A	N/A	N/A	N/A	Unknown	Apr-10	Unknown	<u>10,000</u>	<u>10</u>	<u>10</u>
											10,000	10	10
St. Johns River Power Park ^{4/}		Duval County 12/15/28E (RPC4)									<u>271,836</u>	<u>260</u>	<u>254</u>
	1		ST	BIT	Pet	RR	WA	Unknown	Mar-87	Unknown	135,918	130	127
	2		ST	BIT	Pet	RR	WA	Unknown	May-88	Unknown	135,918	130	127
St. Lucie ^{5/}		St. Lucie County 16/36S/41E									1,000		
	1 ^{7/}		ST	NP	No	TK	No	Unknown	May-76	Unknown	<u>1,743,775</u>	<u>1,873</u>	<u>1,832</u>
	2 ^{7/}		ST	NP	No	TK	No	Unknown	Jun-83	Unknown	723,775	864	845
Turkey Point		Miami Dade County 27/57S/40E									<u>3,783,010</u>	<u>3,519</u>	<u>3,437</u>
	1		ST	FO6	NG	WA	PL	Unknown	Apr-67	Unknown	402,050	398	396
	2 ^{6/}		ST	FO6	NG	WA	PL	Unknown	Apr-68	Unknown	402,050	394	392
	3 ^{7/}		ST	NP	No	TK	No	Unknown	Nov-72	Unknown	877,200	832	808
	4 ^{7/}		ST	NP	No	TK	No	Unknown	Jun-73	Unknown	877,200	717	693
5		CC	NG	FO2	PL	TK	Unknown	May-07	Unknown	1,224,510	1,178	1,148	
West County		Palm Beach County 29&32/43S/40E									<u>2,733,600</u>	<u>4,005</u>	<u>3,657</u>
	1		CC	NG	FO2	PL	TK	Unknown	Aug-09	Unknown	1,366,800	1,335	1,219
	2		CC	NG	FO2	PL	TK	Unknown	Nov-09	Unknown	1,366,800	1,335	1,219
	3		CC	NG	FO2	PL	TK	Unknown	May-11	Unknown	1,366,800	1,335	1,219
Total System Generating Capacity as of December 31, 2012 ^{8/} =											25,337	24,065	
System Firm Generating Capacity as of December 31, 2012 ^{9/} =											25,302	24,030	

1/ These ratings are peak capability.

2/ These ratings represent Florida Power & Light Company's share of Scherer Unit 4, adjusted for transmission losses.

3/ The capacity shown for the PV facility at Space Coast is considered as non-firm generating capacity due to the intermittent nature of the solar resource.

4/ The net capability ratings represent Florida Power & Light Company's share of St. Johns River Park Units 1 and 2, excluding the Jacksonville Electric Authority (JEA) share of 80%.

5/ Total capability of St. Lucie 1 is 987/1,009 MW. FPL's share of St. Lucie 1 is 845/864. FPL's ownership share of St. Lucie Units 1 and 2 is 100% and 85%, respectively, as shown above. FPL's share of the deliverable capacity from each unit is approx. 92.5% and exclude the Orlando Utilities Commission (OUC) and Florida Municipal Power Agency (FMPA) combined portion of approximately 7.44776% per unit.

6/ Currently operating as a synchronous condenser. If needed, it can be converted back to a generating unit per the existing Title V operating permit through the end of 2013 and is not accounted for in Reserve Margin Calculation.

7/ Values for the Nuclear Units are approximate due to the on going testing after the EPU work has been completed.

8/ The Total System Generating Capacity value shown includes FPL-owned firm and non-firm generating capacity.

9/ The System Firm Generating Capacity value shown includes only firm generating capacity.

CHAPTER II

Forecast of Electric Power Demand

(This page is left intentionally blank.)

II. Forecast of Electric Power Demand

II. A. Overview of the Load Forecasting Process

Long-term forecasts of sales, net energy for load (NEL), and peak loads are typically developed on an annual basis for resource planning work at FPL. New long-term forecasts were developed by FPL in early 2013 that replaced the previous long-term load forecasts that were used by FPL during 2012 in much of its resource planning work and which were presented in FPL's 2012 Site Plan. These new load forecasts are utilized throughout FPL's 2013 Site Plan. These forecasts are a key input to the models used to develop FPL's integrated resource plan.

The following pages describe how forecasts are developed for each component of the long-term forecast: sales, NEL, and peak loads. Consistent with past forecasts, the primary drivers to develop these forecasts include economic conditions and weather.

The projections for the national and Florida economies are obtained from the consulting firm IHS Global Insight. Population projections are obtained from the Florida Legislature's Office of Economic and Demographic Research (EDR). These projections are developed in conjunction with the Bureau of Economic and Business Research (BEBR) of the University of Florida. These inputs are quantified and qualified using statistical models in terms of their impact on the future demand for electricity.

Weather is always a key factor that affects FPL's energy sales and peak demand. Three sets of weather variables are developed and used in FPL's forecasting models:

1. Cooling degree-hours based on 72° F, winter heating degree-days based on 66° F, and heating degree-days based on 45° F are used to forecast energy sales.
2. The maximum temperature on the peak day, along with the build-up of cooling degree-hours prior to the peak, are used to forecast Summer peaks.
3. The minimum temperature on the peak day, along with the build-up of heating degree-hours based on 66° F on the day prior to the peak, are used to forecast Winter peaks.

The cooling degree-hours and winter heating degree-days are used to capture the changes in the electric usage of weather-sensitive appliances such as air conditioners and electric space heaters. Heating degree-days based on 45° F are used to capture heating load resulting from sustained periods of unusually cold weather not fully captured

by heating degree-days based on 66° F. A composite hourly temperature profile is derived using hourly temperatures across FPL's service territory. Miami, Ft. Myers, Daytona Beach, and West Palm Beach are the locations from which temperatures are obtained. In developing the composite hourly profile, these regional temperatures are weighted by regional energy sales. The resulting composite temperature is used to derive projected cooling and heating degree-hours and heating degree-days. Similarly, composite temperature and hourly profiles of temperatures are used to calculate the weather variables used in the Summer and Winter peak models.

II. B. Comparison of FPL's Current and Previous Load Forecasts

While reflecting somewhat lower growth for a number of years, FPL's current load forecast is generally in line with the load forecast presented in its 2012 Site Plan. There are four primary factors that are driving the current load forecast: projected customer growth, a projection of gradual recovery following the economic recession in Florida, energy efficiency standards, and the additional load expected as a result of the acquisition of the City of Vero Beach electric utility.

In early 2013, FPL came to an agreement with the City of Vero Beach to purchase the City's electric system. This agreement was approved by the City voters on March 12, 2013. Beginning in January 2014, NEL, customers, and peaks for Vero Beach are included in FPL's forecasts and are reflected in FPL's 2013 Site Plan.

The customer forecast is based on recent population projections as well as the actual levels of customer growth experienced historically and the additional customers expected as a result of the acquisition of Vero Beach. Population projections are derived from the EDR's February 2013 Demographic Estimating Conference. This forecast is generally consistent with previous forecasts indicating a gradual rebound in Florida's population growth. Net migration into Florida fell to a record low in 2009 during the height of the recession. Florida has since experienced some rebound in net migration, but population growth rates have remained low by historical standards. Moderately higher rates of population growth are projected from 2013 until 2017 when the projected rate of population growth gradually begins to decelerate. Consistent with past population projections, the rates of population growth in the later years of the forecast are below the rates historically experienced in Florida.

Effective January 2014 FPL is expected to begin providing electric service to more than 34,000 customers formerly served by the City of Vero Beach. Reflecting this increase, the current forecast shows a significant increase in customer growth in 2014. Thereafter, customer growth is expected to mirror the overall level of population growth in the state. By 2019, the total number of customers served by FPL is expected to exceed five million. Between 2012 and 2022 the total number of customers is projected to increase at an annual rate of 1.4%, the same increase projected in the 2012 Site Plan.

The economic projections incorporated into FPL's load forecast are provided by IHS Global Insight, a leading economic forecasting firm. The economic projections from IHS Global Insight incorporated into the current load forecast indicate less robust growth than that assumed in the 2012 Site Plan forecast. Although IHS Global Insight remains cautiously optimistic on the Florida economy, their current projections for employment and income growth are lower than those incorporated into the 2012 Site Plan forecast.

Estimates of savings from energy efficiency standards are developed by ITRON, a leading expert in this area. Included in these estimates are savings from federal and state energy efficiency standards, including the 2005 National Energy Policy Act, the 2007 Energy Independence and Security Act, and the savings occurring from the use of compact fluorescent bulbs². The impact of these savings began in 2005 and their cumulative impact on the Summer peak is expected to reach 2,898 MW by 2022. The cumulative impact from these savings on NEL is expected to reach 11,850 GWH over the same period while the cumulative impact on the Winter peak is expected to be 1,650 MW by 2022.

Consistent with the forecast presented in FPL's 2012 Site Plan, the total growth projected for the ten-year reporting period of this document is significant. The Summer peak is projected to increase to 26,105 MW by 2022, an increase of 4,665 MW over the 2012 actual Summer peak. Likewise, NEL is projected to reach 130,965 GWH in 2022, an increase of 20,099 GWH from the actual 2012 value.

II.C. Long-Term Sales Forecasts

Long-term forecasts of electricity sales were developed for the major revenue classes and are adjusted to match the NEL forecast. The results of these sales forecasts for the

² Note that in addition to the fact that these energy efficiency standards lower the forecasted load (as described later in this chapter), these standards also lower the potential for efficiency gains that would otherwise be available through utility DSM programs.

years 2013 - 2022 are presented in Schedules 2.1 - 2.3 which appear at the end of this chapter. Econometric models are developed for each revenue class using the statistical software package MetrixND. The methodologies used to develop energy sales forecasts for each jurisdictional revenue class and NEL forecast are outlined below.

1. Residential Sales

Residential electric usage per customer is estimated by using an econometric model. Residential sales are a function of the following variables: cooling degree-hours, winter heating degree-days, heating degree-days based on 45° F, lagged cooling degree-hours, lagged heating degree-days, retail gasoline prices, and Florida real per capita income weighted by the percent of the population employed. The impact of weather is captured by the cooling degree-hours, heating degree-days, and the one month lag of these variables. The impact energy prices have on electricity consumption is captured through retail gasoline prices. As energy prices rise, less disposable income is available for all goods and services, electricity included. To capture economic conditions, the model includes a composite variable based on Florida real per capita income and the percent of the state's population that is employed. Because of the relatively large percentage of Florida's population that was unemployed during the recession, real per capita income alone did not capture the full magnitude of the economic downturn. The composite variable more fully reflects economic conditions. Residential energy sales are forecasted by multiplying the forecasted residential use per customer by the number of residential customers forecasted.

2. Commercial Sales

The commercial sales forecast is also developed using an econometric model. Commercial sales are a function of the following variables: Florida real per capita income weighted by the percent of the population employed, cooling degree-hours, heating degree-hours, lagged cooling degree-hours, a variable designed to reflect the impact of empty homes, dummy variables for the month of December and for the specific months of January 2007 and November 2005, and an autoregressive term. Cooling degree-hours, heating degree-hours, and the one month lag of cooling degree-hours are used to capture weather-sensitive load in the commercial sector.

3. Industrial Sales

The industrial class is comprised of three distinct groups: very small accounts (those with less than 20 kW of demand), medium accounts (those with 21 kW to 499 kW of

demand), and large accounts (those with demands of 500 kW or higher). As such, the forecast is developed using a separate econometric model for each group of industrial customers. The small industrial sales model utilizes the following variables: cooling degree-hours, heating degree-hours, dummy variables for the specific months of February 2009 and August 2004, and an autoregressive term. The medium industrial sales model utilizes the following variables: cooling degree-hours, Florida real per capita income, a dummy variable for the specific month of February 2006, two autoregressive terms, and a moving average term. The large industrial sales model utilizes the following variables: Florida real per capita income, the Consumer Price Index, and dummy variables for the specific months of October 2004, November 2004, and October 2005.

4. Railroad and Railways Sales and Street and Highway Sales

This class consists solely of Miami-Dade County's Metrorail system. The projections for railroad and railways sales are based on historical average use per customer which is multiplied by the forecasted number of customers. The number of customers is based on the planned addition of new Metrorail stations.

The forecast for street and highway sales is developed by first developing a trended use per customer value, then multiplying this value by the number of forecasted customers.

5. Other Public Authority Sales

This revenue class is closed to new customers. This class consists of sports fields and one government account. The forecast for this class is based on its historical usage characteristics.

6. Total Sales to Ultimate Customer

Sales forecasts by revenue class are summed to produce a total sales forecast.

7. Sales for Resale

Sales for resale (wholesale) customers are composed of municipalities and/or electric co-operatives. These customers differ from jurisdictional customers in that they are not the ultimate users of the electricity they buy. Instead, they resell this electricity to their own customers. Currently there are six customers in this class: the Florida Keys Electric Cooperative; City of Key West; Metro-Dade County; Lee County Electric

Cooperative; Wauchula; and Blountstown. In addition, FPL will begin making sales to Seminole Electric Cooperative in June 2014 under a long term agreement³.

Beginning in May 2011, FPL began providing service to the Florida Keys Electric Cooperative under a long-term full requirements contract. Previously FPL was serving the Florida Keys under a partial requirements contract. The sales to Florida Keys Electric Cooperative are based on customer-supplied information and historical load factors.

FPL's sales to the City of Key West are expected to terminate in 2013. Forecasted sales to the City of Key West are based on assumptions regarding their contract demand and expected load factor.

Metro-Dade County sells 60 MW to Progress Energy Florida. Line losses are billed to Metro-Dade under a wholesale contract. This contract expires in 2013.

Lee County has contracted with FPL for FPL to supply a portion of their load through 2013, then to begin serving their entire load beginning in 2014. This contract began in January 2010. Lee County provides a forecast of their sales by delivery point which is used to derive their sales forecast.

FPL's sales to Wauchula began in October 2011 and will continue through December 2016.

Blountstown became an FPL wholesale customer in May 2012. FPL's contract with Blountstown expires in April 2017.

A new contract with Seminole Electric Cooperative is included in the forecast which includes delivery of 200 MW beginning in June 2014 and continuing through May 2021.

II.D. Net Energy for Load (NEL)

An econometric model is developed to produce a NEL per customer forecast. The inputs to the model include Florida real per capita income weighted by the percent of the

³FPL is currently evaluating the possibility of serving the electrical loads of several entities (including Lake Worth) at the time the 2013 Site Plan is being prepared. Because these possibilities are still being evaluated, the load forecast presented in this Site Plan does not include these potential loads.

population employed, and a proxy for energy prices. The model also includes three weather variables: cooling degree-hours, winter heating degree-days, and heating degree-days based on 45° F. In addition, the model also includes variables for energy efficiency standards and a variable designed to capture the impact of empty homes. Seasonal dummy variables are included for the months of February, April, June, September, and November and the specific months of March 2003, May 2004, and November 2005. There is also an autoregressive term in the model.

The energy efficiency variable is included to capture the impacts of the 2005 National Energy Policy Act, the 2007 Energy Independence and Security Act, and the savings occurring from the use of compact fluorescent bulbs. The impact of these savings began in 2005 and their cumulative impact on NEL is expected to reach 11,850 GWH by 2022. This reduction is inclusive of engineering estimates and any resulting behavioral changes. The cumulative 2022 reduction from these energy efficiency standards effectively reduces FPL's NEL for that year by 8.3%. On an incremental basis, net of the reduction already experienced through 2012, the reduction in 2022 is expected to reach 7,883 GWH.

The decline in the number of empty homes resulting from the current housing recovery has affected use per customer and is captured in a separate variable. The forecast was also adjusted for additional load estimated from hybrid vehicles, beginning in 2013, which resulted in an increase of approximately 1,408 GWH by the end of the ten-year reporting period. Other adjustments to the forecast include incremental load resulting from FPL's economic development riders which will impact the forecast beginning in 2013, and result in an increase, on average, of 418 GWH per year between 2013 and 2022, and incremental load from the acquisition of the Vero Beach electric system. The Vero Beach acquisition will add, on average, 824 GWH per year between 2014 and 2022.

The NEL forecast is developed by first multiplying the NEL per customer forecast by the total number of customers forecasted (excluding the customers formerly served by Vero Beach) and then adjusting the forecasted results for the expected incremental load resulting from hybrid vehicles, new wholesale contracts, the Vero Beach acquisition, and FPL's economic development riders. Once the NEL forecast is obtained, total billed sales are computed using a historical ratio of sales to NEL. The sales by class forecasts previously discussed are then adjusted to match the total billed sales. The forecasted NEL values for 2013 - 2022 are presented in Schedule 3.3 that appears at the end of this chapter.

II.E. System Peak Forecasts

The rate of absolute growth in FPL system peak load has been a function of the size of the customer base, varying weather conditions, projected economic conditions, changing patterns of customer behavior, and more efficient appliances and lighting. FPL developed the peak forecast models to capture these behavioral relationships. In addition, FPL's peak forecast also reflects changes in load expected a result of the acquisition of Vero Beach, changes in wholesale contracts, and the expected number of hybrid vehicles.

The savings from energy efficiency standards incorporated into the peak forecast include the impacts from the 2005 National Energy Policy Act, the 2007 Energy Independence and Security Act, and the use of compact fluorescent light bulbs. The impact from these energy efficiency standards began in 2005 and their cumulative impact on the Summer peak is expected to reach 2,898 MW by 2022. This reduction is inclusive of engineering estimates and any resulting behavioral changes. The cumulative 2022 impact from these energy efficiency standards effectively reduces FPL's Summer peak for that year by 10%. On an incremental basis, net of the reduction already experienced through 2012, the impact on the Summer peak from these energy efficiency standards is expected to reach 1,826 MW in 2022. By 2022, the Winter peak is expected to be reduced by 1,650 MW as result of the cumulative impact from these energy efficiency standards since 2005. On an incremental basis, net of the reduction already experienced through 2012, the impact on the Winter peak from these energy efficiency standards is expected to reach 1,126 MW in 2022.

The forecast was also adjusted for additional load estimated from hybrid vehicles which resulted in an increase of approximately 357 MW in the Summer and 151 MW in the Winter by the end of the ten-year reporting period and for the acquisition of the Vero Beach electric system. The Vero Beach acquisition will add 181 MW to the Summer peak, and 201 MW to the Winter peak, forecast by the end of the ten-year reporting period.

The forecasting methodology of Summer, Winter, and monthly system peaks is discussed below. The forecasted values for Summer and Winter peak loads for the years 2013 – 2022 are presented at the end of this chapter in Schedules 3.1 and 3.2, and in Chapter III in Schedules 7.1 through 7.4.

1. System Summer Peak

The Summer peak forecast is developed using an econometric model. The variables included in the model are the 3-month average CPI for Energy, Florida real per capita disposable income, cooling degree-hours in the day prior to the peak, the maximum temperature on the day of the peak, a dummy variables for the year 1994, a variable for energy efficiency standards, and a moving average term. The model is based on the Summer peak contribution per customer which is multiplied by total customers (excluding the customers that have been served by Vero Beach), and adjusted to account for incremental loads resulting from hybrid vehicles, new wholesale contracts, the Vero Beach acquisition, and FPL's economic development riders to derive FPL's system Summer peak.

2. System Winter Peak

Like the system Summer peak model, this model is also an econometric model. The model consists of two weather-related variables: the minimum temperature on the peak day and heating degree-hours for the prior day squared. The model also includes a dummy variable for Winter peaks occurring on weekends and a dummy variable for the year 2008. The forecasted results are adjusted for the impact of energy efficiency standards. The model is based on the Winter peak contribution per customer which is multiplied by total customers (excluding the customers that have been served by Vero Beach), and then adjusted for the expected incremental loads resulting from hybrid vehicles, new wholesale contracts, the Vero Beach acquisition, and FPL's economic development riders.

3. Monthly Peak Forecasts

The forecasting process for monthly peaks consists of the following actions:

- a. Develop the historical seasonal factor for each month by using ratios of historical monthly peaks to the appropriate seasonal peak.
- b. Apply the monthly ratios to their respective seasonal peak forecast to derive the peak forecast by month. This process assumes that the seasonal factors remain unchanged over the forecasting period.

II.F. The Hourly Load Forecast

Forecasted values for system hourly load for the period 2013 - 2022 are produced using a System Load Forecasting “shaper” program. This model uses years of historical FPL hourly system load data to develop load shapes for weekdays, weekend days, and holidays. The model generates a projection of hourly load values based on these load shapes and the forecast of monthly peaks and energy.

II.G. Uncertainty

In order to address uncertainty in the forecasts of aggregate peak demand and NEL, FPL first evaluates the assumptions underlying the forecasts. FPL takes a series of steps in evaluating the input variables, including comparing projections from different sources, identifying outliers in the series, and assessing the series’ consistency with past forecasts. As needed, FPL reviews additional factors which may affect the input variables.

Uncertainty is also addressed in the modeling process. Generally, econometric models are used to forecast the aggregate peak demand and NEL. During the modeling process, the relevant statistics (goodness of fit, F-statistic, P-values, mean absolute deviation (MAD), mean absolute percentage error (MAPE), etc.) are scrutinized to ensure that the models adequately explain historical variation. Once a forecast is developed, it is compared with past forecasts. Deviations from past forecasts are examined in light of changes in input assumptions to ensure that the drivers underlying the forecast are well understood. Finally, forecasts of aggregate peak demand and NEL are compared with the actual values as these become available. An ongoing process of variance analyses is performed. To the extent that the variance analysis identifies large unexplained deviations between the forecast and actual values, revisions to the econometric model may be considered.

The inherent uncertainty in load forecasting is addressed in different ways in regard to FPL’s overall resource planning and operational planning work. In regard to FPL’s resource planning work, FPL’s utilization of a 20% reserve margin criterion (approved by the FPSC) is designed, in part, to maintain reliable electric service to FPL’s customers in light of forecasting uncertainty. In addition, banded forecasts of the projected Summer peak and net energy for load are produced based on an analysis of past forecasting errors. In regard to operational planning, a banded forecast for the projected Summer

and Winter peak days is developed based on the historical weather variations. These bands are then used to develop similar bands for the monthly peaks.

II.H. DSM

The effects of FPL's DSM energy efficiency programs implementation through August 2012 are assumed to be imbedded in the actual usage data for forecasting purposes. The impacts of incremental energy efficiency that FPL plans to implement in the future, plus the cumulative and projected incremental impacts of FPL's load management programs, are accounted for as "line item reductions" to the forecasts as part of the IRP process as shown in Chapter III in Schedules 7.1 through 7.4. After making these adjustments to the load forecasts, the resulting "firm" load forecast is then used in FPL's IRP work.

**Schedule 2.1
History of Energy Consumption
And Number of Customers by Customer Class**

(1) Year	(2) Population	(3) Members per Household	(4) Rural & Residential			(7) Commercial		
			(4) GWh	(5) Average No. of Customers	(6) Average kWh Consumption Per Customer	(7) GWh	(8) Average No. of Customers	(9) Average kWh Consumption Per Customer
2003	8,079,316	2.21	53,485	3,652,663	14,643	41,425	444,650	93,163
2004	8,247,442	2.20	52,502	3,744,915	14,020	42,064	458,053	91,832
2005	8,469,602	2.21	54,348	3,828,374	14,196	43,468	469,973	92,490
2006	8,620,855	2.21	54,570	3,906,267	13,970	44,487	478,867	92,901
2007	8,729,806	2.19	55,138	3,981,451	13,849	45,921	493,130	93,121
2008	8,771,694	2.20	53,229	3,992,257	13,333	45,561	500,748	90,987
2009	8,732,591	2.19	53,950	3,984,490	13,540	45,025	501,055	89,860
2010	8,762,399	2.19	56,343	4,004,366	14,070	44,544	503,529	88,464
2011	8,860,158	2.20	54,642	4,026,760	13,570	45,052	508,005	88,685
2012	8,948,850	2.21	53,434	4,052,174	13,187	45,220	511,887	88,340

Historical Values (2003 - 2012):

Col. (2) represents population only in the area served by FPL.

Col. (4) and Col. (7) represent actual energy sales including the impacts of existing conservation. These values are at the meter.

Col. (5) and Col. (8) represent the annual average of the twelve monthly values.

**Schedule 2.1
Forecast of Energy Consumption
And Number of Customers by Customer Class**

(1) Year	(2) Population	(3) Members per Household	(4) Rural & Residential			(7) Commercial		
			(4) GWh	(5) Average No. of Customers	(6) Average kWh Consumption Per Customer	(7) GWh	(8) Average No. of Customers	(9) Average kWh Consumption Per Customer
2013	8,987,099	2.20	54,824	4,085,045	13,421	46,019	519,848	88,523
2014	9,162,108	2.20	56,113	4,164,594	13,474	47,387	528,330	89,691
2015	9,284,559	2.20	57,122	4,220,254	13,535	48,441	537,176	90,178
2016	9,418,917	2.20	57,976	4,281,326	13,542	49,579	546,026	90,799
2017	9,557,516	2.20	58,469	4,344,325	13,459	50,224	554,623	90,555
2018	9,696,552	2.20	59,084	4,407,524	13,405	50,912	562,886	90,449
2019	9,834,273	2.20	59,668	4,470,124	13,348	51,493	570,924	90,193
2020	9,967,411	2.20	60,439	4,530,641	13,340	52,250	578,931	90,252
2021	10,092,586	2.20	61,011	4,587,539	13,299	52,858	586,989	90,049
2022	10,217,742	2.20	61,832	4,644,428	13,313	53,676	595,193	90,182

Projected Values (2013 - 2022):

Col. (2) represents population only in the area served by FPL.

Col. (4) and Col. (7) represent forecasted energy sales that do not include the impact of incremental conservation. These values are at the meter.

Col. (5) and Col. (8) represent the annual average of the twelve monthly values.

**Schedule 2.2
History of Energy Consumption
And Number of Customers by Customer Class**

(1)	(10)	(11)	(12)	(13)	(14)	(15)	(16)
Year	Industrial			Railroads & Railways GWh	Street & Highway Lighting GWh	Sales to Public Authorities GWh	Sales to Ultimate Consumers GWh
	GWh	Average No. of Customers	Average kWh Consumption Per Customer				
2003	4,004	17,029	235,135	93	425	64	99,496
2004	3,964	18,512	214,139	93	413	58	99,095
2005	3,913	20,392	191,873	95	424	49	102,296
2006	4,036	21,211	190,277	94	422	49	103,659
2007	3,774	18,732	201,499	91	437	53	105,415
2008	3,587	13,377	268,168	81	423	37	102,919
2009	3,245	10,084	321,796	80	422	34	102,755
2010	3,130	8,910	351,318	81	431	28	104,557
2011	3,086	8,691	355,104	82	437	27	103,327
2012	3,024	8,743	345,871	81	441	25	102,226

Historical Values (2003 - 2012):

Col. (10) and Col.(15) represent actual energy sales including the impacts of existing conservation. These values are at the meter.

Col. (11) represents the annual average of the twelve monthly values.

Col. (16) = Col. (4) + Col. (7) + Col. (10) + Col. (13) + Col. (14) + Col. (15).

**Schedule 2.2
Forecast of Energy Consumption
And Number of Customers by Customer Class**

(1)	(10)	(11)	(12)	(13)	(14)	(15)	(16)
Year	Industrial			Railroads & Railways GWh	Street & Highway Lighting GWh	Sales to Public Authorities GWh	Sales to Ultimate Consumers GWh
	GWh	Average No. of Customers	Average kWh Consumption Per Customer				
2013	2,936	8,909	329,522	93	453	26	104,350
2014	2,909	9,192	316,531	93	461	26	106,988
2015	2,892	9,734	297,117	93	468	25	109,042
2016	2,868	10,247	279,865	93	475	25	111,016
2017	2,830	10,594	267,174	93	482	25	112,123
2018	2,775	10,703	259,320	93	488	25	113,378
2019	2,726	10,667	255,544	93	494	24	114,498
2020	2,665	10,596	251,510	93	500	24	115,970
2021	2,598	10,520	246,957	93	505	24	117,089
2022	2,540	10,573	240,208	93	510	24	118,674

Projected Values (2013 - 2022):

Col. (10) and Col.(15) represent forecasted energy sales that do not include the impact of incremental conservation. These values are at the meter.

Col. (11) represents the annual average of the twelve monthly values.

Col. (16) = Col. (4) + Col. (7) + Col. (10) + Col. (13) + Col. (14) + Col. (15).

**Schedule 2.3
History of Energy Consumption
And Number of Customers by Customer Class**

(1)	(17)	(18)	(19)	(20)	(21)
<u>Year</u>	Sales for Resale <u>GWh</u>	Utility Use & Losses <u>GWh</u>	Net Energy For Load <u>GWh</u>	Average No. of Other <u>Customers</u>	Total Average Number of <u>Customers</u>
2003	1,511	7,386	108,393	2,879	4,117,221
2004	1,531	7,467	108,093	3,029	4,224,509
2005	1,506	7,498	111,301	3,156	4,321,895
2006	1,569	7,909	113,137	3,218	4,409,563
2007	1,499	7,401	114,315	3,276	4,496,589
2008	993	7,092	111,004	3,348	4,509,730
2009	1,155	7,394	111,303	3,439	4,499,067
2010	2,049	7,870	114,475	3,523	4,520,328
2011	2,176	6,950	112,454	3,596	4,547,051
2012	2,237	6,403	110,866	3,645	4,576,449

Historical Values (2003 - 2012):

Col. (19) represents actual energy sales including the impacts of existing conservation.

Col. (19) = Col. (16) + Col. (17) + Col. (18). Historical NEL includes the impacts of existing conservation and agrees to Col. (5) on schedule 3.3. Historical GWh, prior to 2011, are based on a fiscal year beginning 12/29 and ending 12/28. The 2011 value is based on 12/29/10 to 12/31/11. The 2012 value is based on calendar year.

Col. (20) represents the annual average of the twelve monthly values.

Col. (21) = Col. (5) + Col. (8) + Col. (11) + Col. (20).

**Schedule 2.3
Forecast of Energy Consumption
And Number of Customers by Customer Class**

(1)	(17)	(18)	(19)	(20)	(21)
<u>Year</u>	Sales for Resale <u>GWh</u>	Utility Use & Losses <u>GWh</u>	Net Energy For Load <u>GWh</u>	Average No. of Other <u>Customers</u>	Total Average Number of <u>Customers</u>
2013	2,174	6,512	113,036	3,707	4,617,509
2014	4,924	6,806	118,718	3,763	4,705,879
2015	5,573	6,730	121,345	3,817	4,770,981
2016	5,620	6,817	123,453	3,867	4,841,466
2017	5,593	6,870	124,586	3,913	4,913,456
2018	5,636	6,944	125,957	3,958	4,985,069
2019	5,696	7,006	127,200	3,999	5,055,714
2020	5,763	7,095	128,829	4,039	5,124,207
2021	5,342	7,112	129,543	4,075	5,189,124
2022	5,059	7,231	130,965	4,110	5,254,304

Projected Values (2013 - 2022):

Col. (19) represents forecasted energy sales that do not include the impact of incremental conservation and agrees to Col. (2) on Schedule 3.3.

Col. (19) = Col. (16) + Col. (17) + Col. (18). These values are based on calendar year.

Col. (20) represents the annual average of the twelve monthly values.

Col. (21) = Col. (5) + Col. (8) + Col. (11) + Col. (20).

**Schedule 3.1
History of Summer Peak Demand (MW)**

(1)	(2)	(3)	(4)	(5)	(6)	(7)	(8)	(9)	(10)
Year	Total	Wholesale	Retail	Interruptible Management	Res. Load Management	Residential Conservation	C/I Load Management	C/I Conservation	Net Firm Demand
2003	19,668	253	19,415	0	892	798	577	554	18,200
2004	20,545	258	20,287	0	894	846	588	577	19,063
2005	22,361	264	22,097	0	902	895	600	611	20,858
2006	21,819	256	21,563	0	928	948	635	640	20,256
2007	21,962	261	21,701	0	952	982	716	683	20,295
2008	21,060	181	20,879	0	966	1,042	760	706	19,334
2009	22,351	249	22,102	0	981	1,097	811	732	20,558
2010	22,256	419	21,837	0	990	1,181	815	758	20,451
2011	21,619	427	21,192	0	1,000	1,281	821	781	19,798
2012	21,440	425	21,015	0	1,027	1,328	827	797	19,586

Historical Values (2003 - 2012):

Col. (2) - Col. (4) are actual values for historical Summer peaks. As such, they incorporate the effects of conservation (Col. 7 & Col. 9), and may incorporate the effects of load control if load control was operated on these peak days. Therefore, Col. (2) represents the actual Net Firm Demand.

Col. (5) - Col. (9) represent actual DSM capabilities starting from January 1988 and are annual (12-month) values except for 2012 values which are through August.

Col. (10) represents a HYPOTHETICAL "Net Firm Demand" as if the load control values had definitely been exercised on the peak. Col. (10) is derived by the formula: Col. (10) = Col.(2) - Col.(6) - Col.(8).

**Schedule 3.1
Forecast of Summer Peak Demand (MW)**

(1)	(2)	(3)	(4)	(5)	(6)	(7)	(8)	(9)	(10)
August of Year	Total	Wholesale	Retail	Interruptible Management	Res. Load Management*	Residential Conservation	C/I Load Management*	C/I Conservation	Net Firm Demand
2013	21,790	399	21,391	0	1,056	64	854	32	19,785
2014	22,928	1,184	21,744	0	1,072	128	889	64	20,775
2015	23,359	1,191	22,168	0	1,081	194	907	96	21,080
2016	23,733	1,197	22,536	0	1,090	261	925	128	21,329
2017	24,122	1,182	22,940	0	1,099	327	943	160	21,593
2018	24,493	1,189	23,304	0	1,109	393	961	192	21,839
2019	24,901	1,196	23,705	0	1,118	459	979	224	22,121
2020	25,302	1,203	24,099	0	1,127	506	996	250	22,422
2021	25,560	1,010	24,550	0	1,136	557	1,014	273	22,580
2022	26,105	1,017	25,088	0	1,145	608	1,032	295	23,025

Projected Values (2013 - 2022):

Col. (2) - Col. (4) represent FPL's forecasted peak and does not include incremental conservation, cumulative load management, or incremental load management.

Col. (5) - Col. (9) represent cumulative load management, and incremental conservation and load management. All values are projected August values.

Col. (8) represents FPL's Business On Call, CDR, CILC, and Curtailable programs/rates.

Col. (10) represents a "Net Firm Demand" which accounts for all of the incremental conservation and assumes all of the load control is implemented on the peak. Col. (10) is derived by using the formula: Col. (10) = Col. (2) - Col. (5) - Col. (6) - Col. (7) - Col. (8) - Col. (9).

* Res. Load Management and C/I Load Management include MW values of load management from Lee County and FKEC.

**Schedule 3.2
History of Winter Peak Demand:Base Case**

(1)	(2)	(3)	(4)	(5)	(6)	(7)	(8)	(9)	(10)
Year	Total	Firm Wholesale	Retail	Interruptible	Res. Load Management	Residential Conservation	C/I Load Management	C/I Conservation	Net Firm Demand
2003	20,190	246	19,944	0	802	546	453	206	18,935
2004	14,752	211	14,541	0	813	567	534	227	13,405
2005	18,108	225	17,883	0	816	583	542	233	16,751
2006	19,683	225	19,458	0	823	600	550	240	18,311
2007	16,815	223	16,592	0	846	620	577	249	15,392
2008	18,055	163	17,892	0	868	644	636	279	16,551
2009	20,081	207	19,874	0	881	666	676	285	18,524
2010	24,346	500	23,846	0	895	687	721	291	22,730
2011	21,126	383	20,743	0	903	717	723	303	19,501
2012	17,934	382	17,552	0	856	755	722	314	16,356

Historical Values (2003 - 2012):

Col. (2) - Col. (4) are actual values for historical Winter peaks. As such, they incorporate the effects of conservation (Col. 7 & Col. 9), and may incorporate the effects of load control if load control was operated on these peak days. Therefore, Col. (2) represents the actual Net Firm Demand. For year 2011, the actual peaked occurred in December of 2010.

Col. (5) - Col. (9) for 2003 through 2012 represent actual DSM capabilities starting from January 1988 and are annual (12-month) values.

Col. (10) represents a HYPOTHETICAL "Net Firm Demand" as if the load control values had definitely been exercised on the peak. Col. (10) is derived by the formula: Col. (10) = Col.(2) - Col.(6) - Col.(8).

**Schedule 3.2
Forecast of Winter Peak Demand:Base Case**

(1)	(2)	(3)	(4)	(5)	(6)	(7)	(8)	(9)	(10)
January of Year	Total	Firm Wholesale	Retail	Interruptible	Res. Load Management*	Residential Conservation	C/I Load Management*	C/I Conservation	Net Firm Demand
2013	20,270	410	19,860	0	863	27	578	12	18,790
2014	21,593	941	20,652	0	880	66	603	23	20,022
2015	22,154	1,142	21,012	0	887	108	612	33	20,513
2016	22,430	1,143	21,287	0	895	151	621	44	20,719
2017	22,662	1,130	21,532	0	902	193	630	55	20,882
2018	22,898	1,123	21,775	0	910	235	638	66	21,049
2019	23,125	1,123	22,002	0	917	278	647	76	21,207
2020	23,356	1,124	22,233	0	924	311	656	85	21,380
2021	23,601	1,125	22,476	0	932	341	665	93	21,571
2022	23,670	925	22,745	0	939	371	673	100	21,587

Projected Values (2013 - 2022):

Col. (2) - Col. (4) represent FPL's forecasted peak and does not include incremental conservation, cumulative load management, or incremental load management.

Col. (5) - Col. (9) represent cumulative load management, and incremental conservation and load management. All values are projected January values.

Col. (8) represents FPL's Business On Call, CDR, CILC, and Curtailable programs/rates.

Col. (10) represents a "Net Firm Demand" which accounts for all of the incremental conservation and assumes all of the load control is implemented on the peak. Col. (10) is derived by using the formula: Col. (10) = Col. (2) - Col. (5) - Col. (6) - Col. (7) - Col. (8) - Col. (9).

* Res. Load Management and C/I Load Management include MW values of load management from Lee County and FKEC.

Schedule 3.3
History of Annual Net Energy for Load (GWh)
 (All values are "at the generator" values except for Col (8))

(1)	(2)	(3)	(4)	(5)	(6)	(7)	(8)	(9)
Year	Net Energy For Load without DSM GWh	Residential Conservation GWh	C/I Conservation GWh	Actual Net Energy For Load GWh	Sales for Resale GWh	Utility Use & Losses GWh	Total Billed Retail Energy Sales (GWh)	Load Factor(%)
2003	111,784	1,773	1,619	108,393	1,511	7,386	99,496	62.9%
2004	111,659	1,872	1,693	108,093	1,531	7,467	99,095	60.1%
2005	115,065	1,970	1,793	111,301	1,506	7,498	102,296	56.8%
2006	117,116	2,078	1,901	113,137	1,569	7,909	103,659	59.2%
2007	118,518	2,138	2,066	114,315	1,499	7,401	105,415	59.4%
2008	115,379	2,249	2,126	111,004	993	7,092	102,919	60.2%
2009	115,844	2,345	2,196	111,303	1,155	7,394	102,755	56.8%
2010	119,220	2,487	2,259	114,475	2,049	7,870	104,557	58.7%
2011	117,460	2,683	2,324	112,454	2,176	6,950	103,327	59.4%
2012	116,083	2,823	2,394	110,866	2,237	6,403	102,226	59.0%

Historical Values (2003 - 2012):

Col. (2) represents derived "Total Net Energy For Load w/o DSM". The values are calculated using the formula: Col. (2) = Col. (3) + Col. (4) + Col. (5).

Col. (3) & Col. (4) are DSM values starting in January 1988 and are annual (12-month) values. Col. (3) and Col. (4) for 2012 are "estimated actuals" and are also annual (12-month) values. The values represent the total GWh reductions experienced each year .

Col. (5) is the actual Net Energy for Load (NEL) for years 2003 - 2012.

Col. (8) is the Total Retail Billed Sales. The values are calculated using the formula: Col. (8) = Col. (5) - Col. (6) - Col. (7). These values are at the meter.

Col. (9) is calculated using Col. (5) from this page and Col. (2), "Total", from Schedule 3.1 using the formula: Col. (9) = ((Col. (5)*1000) / ((Col. (2) * 8760) Adjustments are made for leap years.

Schedule 3.3
Forecast of Annual Net Energy for Load (GWh)
 (All values are "at the generator" values except for Col (8))

(1)	(2)	(3)	(4)	(5)	(6)	(7)	(8)	(9)
Year	Forecasted Net Energy For Load without DSM GWh	Residential Conservation GWh	C/I Conservation GWh	Net Energy For Load Adjusted for DSM GWh	Sales for Resale GWh	Utility Use & Losses GWh	Forecasted Total Billed Retail Energy Sales w/o DSM GWh	Load Factor(%)
2013	113,036	48	26	112,962	2,174	6,512	104,350	59.2%
2014	118,718	147	78	118,493	4,924	6,806	106,988	59.1%
2015	121,345	248	131	120,966	5,573	6,730	109,042	59.3%
2016	123,453	348	186	122,919	5,620	6,817	111,016	59.2%
2017	124,586	449	241	123,896	5,593	6,870	112,123	59.0%
2018	125,957	549	296	125,112	5,636	6,944	113,378	58.7%
2019	127,200	650	351	126,199	5,696	7,006	114,498	58.3%
2020	128,829	730	406	127,692	5,763	7,095	115,970	58.0%
2021	129,543	801	450	128,292	5,342	7,112	117,089	57.9%
2022	130,965	871	488	129,605	5,059	7,231	118,674	57.3%

Projected Values (2013 - 2022):

Col. (2) represents Forecasted Net Energy for Load and does not include incremental DSM from 2013 - on. The Col. (2) values are extracted from Schedule 2.3, Col(19). The effects of conservation implemented prior to September 2012 are incorporated into the load forecast values in Col. (2).

Col. (3) & Col. (4) are forecasted values of the reduction on sales from incremental conservation from Jan 2013 - on and are mid-year (6-month) values reflecting DSM signups occurring evenly throughout each year.

Col. (5) is the forecasted Net Energy for Load (NEL) after adjusting for impacts of incremental DSM for years 2013 - 2022 using the formula: Col. (5) = Col. (2) - Col. (3) - Col. (4)

Col. (8) is the Total Retail Billed Sales. The values are calculated using the formula: Col. (8) = Col. (2) - Col. (6) - Col. (7). These values are at the meter.

Col. (9) is calculated using Col. (2) from this page and Col. (2), "Total", from Schedule 3.1. Col. (9) = ((Col. (2)*1000) / ((Col. (2) * 8760) Adjustments are made for leap years.

Schedule 4
Previous Year Actual and Two-Year Forecast of
Retail Peak Demand and Net Energy for Load (NEL) by Month

(1)	(2)	(3)	(4)	(5)	(6)	(7)
	2012 Actual		2013 FORECAST		2014 FORECAST	
Month	Total Peak Demand MW	NEL GWh	Total Peak Demand MW	NEL GWh	Total Peak Demand MW	NEL GWh
JAN	17,934	7,979	20,270	8,426	21,593	8,842
FEB	16,228	7,702	16,551	7,547	17,632	7,942
MAR	16,310	8,640	16,717	8,499	17,808	8,903
APR	18,108	8,509	17,342	8,649	18,247	9,030
MAY	19,981	9,895	19,375	9,962	20,386	10,378
JUN	20,351	10,243	20,696	10,378	21,776	10,873
JUL	21,343	11,226	21,277	11,228	22,387	11,748
AUG	21,440	11,203	21,790	11,266	22,928	11,792
SEP	19,711	10,234	20,993	10,471	22,089	11,005
OCT	19,337	9,654	19,654	9,812	20,680	10,351
NOV	14,282	7,423	18,105	8,309	18,576	8,829
DEC	16,025	8,157	18,008	8,489	18,476	9,026
Annual Values:		110,866		113,036		118,718

Col. (3) annual value shown is consistent with value shown in Col.(5) of Schedule 3.3.

Cols. (4) - (7) do not include the impacts of cumulative load management, incremental conservation, and incremental load management.

Cols. (5) and Col. (7) annual values shown are consistent with values shown in Col.(2) of Schedule 3.3.

CHAPTER III

Projection of Incremental Resource Additions

(This page is left intentionally blank.)

III. Projection of Incremental Resource Additions

III.A FPL's Resource Planning:

FPL utilizes its well established integrated resource planning (IRP) process in whole or in part as analysis needs are warranted, to determine when new resources are needed, what the magnitude of the needed resources are, and what type of resources should be added. The timing and type of new power plants, the primary subjects of this document, are determined as part of the IRP process work.

This section describes FPL's basic IRP process. Some of the key assumptions, in addition to a new load forecast, that were used in developing the resource plan presented in this Site Plan are also discussed.

Four Fundamental Steps of FPL's Resource Planning:

There are 4 fundamental steps to FPL's resource planning. These steps can be described as follows:

Step 1: Determine the magnitude and timing of FPL's new resource needs;

Step 2: Identify which resource options and resource plans can meet the determined magnitude and timing of FPL's resource needs (i.e., identify competing options and resource plans);

Step 3: Evaluate the competing options and resource plans in regard to system economics and non-economic factors; and,

Step 4: Select a resource plan and commit, as needed, to near-term options.

Figure III.A.1 graphically outlines the 4 steps.

Overview of FPL's IRP Process

Fundamental IRP Steps

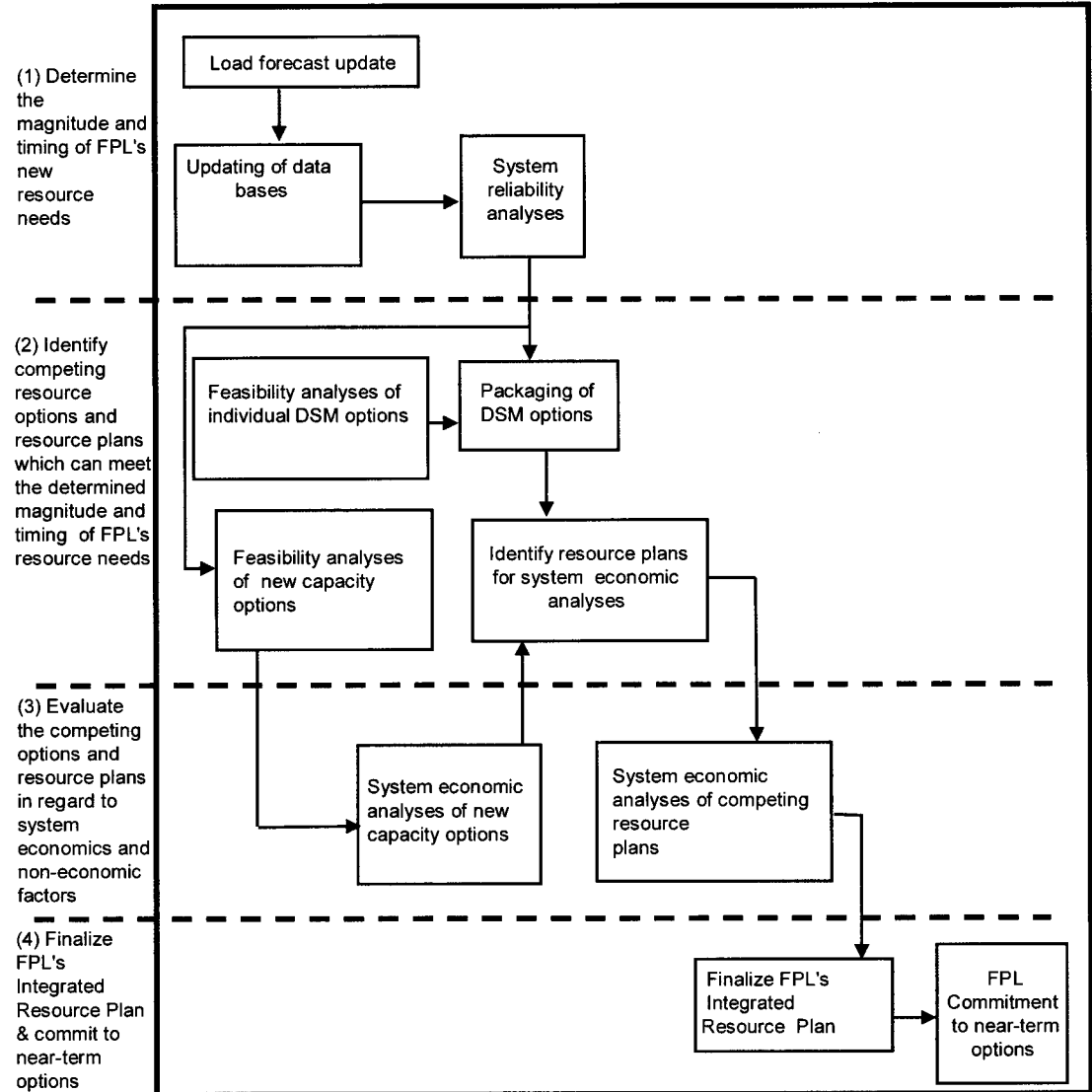

Figure III.A.1: Overview of FPL's IRP Process

Step 1: Determine the Magnitude and Timing of FPL's New Resource Needs:

The first of the four resource planning steps, determining the magnitude and timing of FPL's resource needs, is essentially a determination of the amount of capacity or megawatts (MW) of load reduction, new capacity additions, or a combination of both load reduction and new capacity additions that are needed to maintain system reliability. Also determined in this step is when the MW additions are needed to meet FPL's reliability criteria. This step is often referred to as a reliability assessment, or resource adequacy, analysis for the utility system.

Step 1 typically starts with an updated load forecast. Several databases are also updated in this first fundamental step, not only with the new information regarding forecasted loads, but also with other information that is used in many of the fundamental steps in resource planning. Examples of this new information include, but are not limited to: delivered fuel price projections, current financial and economic assumptions, and power plant capability and operating assumptions. FPL also includes key assumptions regarding three specific resource areas: (1) near-term construction capacity additions, (2) firm capacity power purchases, and (3) demand side management (DSM) implementation.

The first of these assumptions is based on new generating capacity additions that have been approved by the Florida Public Service Commission (FPSC) either through Determination of Need proceedings that evaluated both the need for, and the cost-effectiveness of, each of the new capacity additions or through other FPSC dockets. These generating capacity additions have also either received the necessary Site Certification approvals from either the Secretary of the Florida Department of Environmental Protection (FDEP) or the Governor and Cabinet (acting as the Siting Board), or these approvals have been applied for. There is also work in progress to obtain the necessary federal and state licenses, permits, and approvals for construction and operation of two new nuclear units. The earliest practical deployment date for the first of the two new nuclear units, Turkey Point Unit 6, is currently projected to be 2022, a date within the reporting period of this Site Plan.

These generating capacity additions include:

- The completion of the extended power uprates (EPU) project at FPL's existing Turkey Point Unit 4 nuclear unit. Similar EPU projects were completed during 2012 at FPL's

three other existing nuclear power plants (St. Lucie Units 1 & 2 and Turkey Point Unit 3). The completion of the EPU project at Turkey Point Unit 4 is projected to add approximately 115 MW of incremental nuclear capacity and the total incremental nuclear capacity from the EPU project for all four nuclear plants is projected to be more than 500 MW. The FPSC approved the need for the EPU project in April 2008.

- Two existing generating plant sites, each featuring two older fossil fuel-fired steam generating units, are currently in the process of being modernized. The steam generating units originally at these sites have been removed and are in the process of being replaced with one new, highly efficient combined cycle (CC) unit at each site. The new CC plant at FPL's Cape Canaveral site is projected to be placed in-service in mid-2013. This new CC unit (called the Cape Canaveral Next Generation Clean Energy Center (CCEC)) is projected to have a peak Summer output of 1,210 MW. The new CC unit at FPL's Riviera Beach site (called the Riviera Beach Next Generation Clean Energy Center (RBEC)) is projected to be placed in-service in mid-2014 and it is expected to have a peak Summer output of 1,212 MW. These modernizations were approved by the FPSC in September 2008. The site certification application for Cape Canaveral was granted in October 2009. The site certification application for Riviera Beach was granted in November 2009.
- Similar to the two modernization projects mentioned above, the four existing steam units at the Port Everglades site are being removed and will be replaced with a new highly efficient CC unit. Two of these four existing steam units were removed in the fourth quarter of 2012 and the other two steam units are projected to be removed in the first half of 2013. The new generating unit, called the Port Everglades Next Generation Clean Energy Center (PEEC), is projected to be in-service in mid-2016 and is projected to have a peak Summer output of 1,277 MW. The FPSC provided the final need order for this modernization project on April 9th, 2012. The site certification application for Port Everglades was granted in October 2012.
- In the fourth quarter of 2011, FPL started upgrading the 7FA combustion turbines (CT) that are components at a number of its existing CC units. These upgrades will economically benefit FPL's customers by increasing the MW output of these CC units by approximately 228 MW (Summer peak value) in total. As reflected in Schedule 1 in Chapter I, 70 MW of the increased capacity from these CT upgrades is already in service. The work for the remaining upgrades is continuing and the project is projected to be completed in 2015.
- FPL is continuing its work to obtain all of the licenses, permits, and approvals that will be necessary to construct and operate two new nuclear units at its Turkey Point site. These licenses, permits, and approvals will provide FPL with the opportunity to

construct these nuclear units at Turkey Point for a time expected to be up to 20 years from the time the licenses and permits are granted, and then to operate the units for at least 40 years thereafter. FPL received need determination approval from the FPSC for the two nuclear units in April 2008 in Order No. PSC-08-0237-FOF-EI. The earliest practical deployment dates for the first of these two new units, Turkey Point Unit 6, is currently projected to be 2022. This new nuclear unit is projected to have a peak Summer output of 1,100 MW.

- As part of FPL's acquisition of Vero Beach's electric utility system, FPL will take ownership of Vero Beach's five existing generating units starting January 2014. The current plan is to immediately retire three of these older generating units and operate the remaining two, which supply approximately 44 MW (Summer) of combined cycle capacity, for a maximum of three years.

These new generating units and generating capacity additions were selected for a variety of reasons including cost-effectiveness, significant system fuel savings, fuel diversity, mitigation of regional generation/load imbalances, and significant system emission reductions, including greenhouse gas emission reductions.

The second of these assumptions involves firm capacity power purchases. FPL's current projection of firm capacity purchases has changed from the projection in the 2012 Site Plan. FPL's current projection includes an additional 70 MW from the Palm Beach Solid Waste Authority (SWA) starting in year 2015 which is a year earlier than projected in the 2012 Site Plan. Also, FPL now projects that its purchase agreement with Jacksonville Electric Authority (JEA) for St. Johns Regional Power Park (SJRPP)-based capacity and energy will allow FPL to continue to receive purchased capacity and energy until November 2017. At that time, FPL projects that Internal Revenue Service (IRS) regulations regarding the amount of energy that FPL can receive will result in the suspension of any further capacity and energy by FPL.⁴ As part of the agreement that FPL will begin serving Vero Beach's electrical needs beginning in January 2014, FPL has acquired two existing power purchase agreements totaling approximately 37 MW of coal-fired capacity. These agreements will run through the end of 2016. In addition, FPL projects that it will begin receiving a total of 180 MW of firm capacity in 2021 from biomass-based power purchase agreements with EcoGen.

⁴ FPL's projected suspension date for the SJRPP purchase is based on a system reliability perspective and represents the earliest projected date at which the suspension of capacity and energy could occur.

In total, the projected firm capacity purchases are from a combination of utility and independent power producers. Details, including the annual total capacity values for these purchases, are presented in Chapter I in Tables I.B.1 and I.B.2. These purchased capacity amounts were incorporated in FPL's resource planning work.

The third of these assumptions involves a projection of the amount of additional DSM that is anticipated to be implemented annually over the ten-year period. Since 1994, FPL's resource planning work has assumed that, at a minimum, the DSM MW called for in FPL's approved DSM Plan will be achieved. The resource plan presented in FPL's 2013 Site Plan fully accounts for the annual DSM implementation direction provided by the FPSC in 2011 that addresses the years through 2019. In addition, for planning purposes in this document, FPL also assumes an additional 100 MW per year of DSM for the remaining years addressed in this Site Plan, 2020 through 2022.

These key assumptions, plus the other updated information described above, are then applied in the first fundamental step: the determination of the magnitude and the timing of FPL's future resource needs. This determination is accomplished by system reliability analyses which for FPL have traditionally been based on dual planning criteria of a minimum peak period reserve margin of 20% (FPL applies this to both Summer and Winter peaks) and a maximum loss-of-load probability (LOLP) of 0.1 day per year. Both of these criteria are commonly used throughout the utility industry.

Historically, two types of methodologies, deterministic and probabilistic, have been utilized in system reliability analysis. The calculation of excess firm capacity at the annual system peaks (reserve margin) is the most common method, and this relatively simple deterministic calculation can be performed on a spreadsheet. It provides an indication of the adequacy of a generating system's capacity resources compared to its load during peak periods. However, deterministic methods do not take into account probabilistic-related elements such as the impact of individual unit failures. For example: two 50 MW units which can be counted on to run 90% of the time are more valuable in regard to utility system reliability than is one 100 MW unit which can also be counted on to run 90% of the time. Probabilistic methods also recognize the value of being part of an interconnected system with access to multiple capacity sources.

For this reason, probabilistic methodologies have been used to provide an additional perspective on the reliability of a generating system. There are a number of probabilistic methods that are being used to perform system reliability analyses. Among the most

widely used is loss-of-load probability (LOLP) which FPL utilizes. Simply stated, LOLP is an index of how well a generating system may be able to meet its demand (i.e., a measure of how often load may exceed available resources). In contrast to reserve margin, the calculation of LOLP looks at the daily peak demands for each year, while taking into consideration such probabilistic events as the unavailability of individual generators due to scheduled maintenance or forced outages.

LOLP is expressed in units of the “number of times per year” that the system demand could not be served. The standard for LOLP accepted throughout the industry is a maximum of 0.1 day per year. This analysis requires a more complicated calculation methodology than does the reserve margin analysis. LOLP analyses are typically carried out using computer software models such as the Tie Line Assistance and Generation Reliability (TIGER) program used by FPL.

The result of the first fundamental step of resource planning is a projection of how many new MW of resources are needed to meet both reserve margin and LOLP criteria, and thus maintain system reliability, and when the MW are needed. Information regarding the timing and magnitude of these resource needs is then used in the second fundamental step: identifying resource options and resource plans that can meet the determined magnitude and timing of FPL’s resource needs.

Step 2: Identify Resource Options and Plans That Can Meet the Determined Magnitude and Timing of FPL’s Resource Needs:

The initial activities associated with this second fundamental step of resource planning generally proceed concurrently with the activities associated with Step 1. During Step 2, preliminary economic screening analyses of new capacity options that are identical, or virtually identical, in regard to certain key characteristics may be conducted to determine which new capacity options appear to be the most competitive on FPL’s system. This preliminary analysis work can also help identify capacity size (MW) values, projected construction/permitting schedules, and operating parameters and costs. Similarly, preliminary economic screening analyses of new DSM options and/or continued growth in existing DSM options are often conducted.

FPL typically utilizes the P-MArea production cost model and a Fixed Cost Spreadsheet, and/or the Strategist model, as well as spreadsheet analyses, to perform the preliminary economic screening of generation resource options. For the preliminary economic

screening analyses of DSM resource options, FPL typically uses its DSM cost-effectiveness model which is an FPL spreadsheet model utilizing the FPSC's approved methodology for performing preliminary cost-effectiveness screening of individual DSM measures and programs. FPL also utilizes its non-linear programming model for analyzing the potential for lowering system peak loads through additional load management/demand response capability. Then FPL typically utilizes its linear programming model to develop DSM portfolios that are subsequently used in developing resource plans for final system analyses of DSM-based resource plans.

The individual new resource options emerging from these preliminary economic screening analyses are then typically "packaged" into different resource plans which are designed to meet the system reliability criteria. In other words, resource plans are created by combining individual resource options so that the timing and magnitude of FPL's projected new resource needs are met. The creation of these competing resource plans is typically carried out using spreadsheet and/or dynamic programming techniques.

At the conclusion of the second fundamental resource planning step, a number of different combinations of new resource options (i.e., resource plans) of a magnitude and timing necessary to meet FPL's resource needs are identified.

Step 3: Evaluate the Competing Options and Resource Plans in Regard to System Economics and Non-Economic Factors:

At the completion of fundamental steps 1 & 2, the most viable new resource options have been identified, and these resource options have been combined into a number of resource plans which meet the magnitude and timing of FPL's resource needs. The stage is set for evaluating these resource options and resource plans in final, or system, economic analyses that attempt to account for all of the impacts to the FPL system from the competing resource options/resource plans. (A number of these system impacts are typically not accounted for in preliminary economic screening analyses.) In FPL's 2012 and early 2013 resource planning work, once the resource plans were developed, FPL utilized the P-MArea production cost model and a Fixed Cost Spreadsheet, and/or the Strategist model, to perform the system economic analyses.

The basic economic analyses of the competing resource plans focus on total system economics. The standard basis for comparing the economics of competing resource plans is their relative impact on FPL's electricity rate levels, with the objective generally

being to minimize FPL's projected levelized system average electric rate (i.e., a Rate Impact Measure or RIM methodology). In cases in which the DSM contribution was assumed as a given and the only competing options were new generating units and/or purchase options, comparisons of competing resource plans' impacts on electricity rates and on system revenue requirements will yield identical outcomes in regard to the relative rankings of the resource options being evaluated. Consequently, the competing options and resource plans in such cases can be evaluated on a system cumulative present value revenue requirement (CPVRR) basis.

Other factors are also included in FPL's evaluation of resource options and resource plans. While these factors may have an economic component or impact, they are often discussed in quantitative, but non-economic, terms such as percentages, tons, etc. rather than in terms of dollars. These factors are often referred to by FPL as "system concerns" that include (but are not limited to) maintaining/enhancing fuel diversity in the FPL system, system emission levels, and maintaining a regional balance between load and generating capacity, particularly in the Southeastern Florida counties of Miami-Dade and Broward. In conducting the evaluations needed to determine which resource options and resource plans are best for FPL's system, the non-economic evaluations are conducted with an eye to whether the system concern is positively or negatively impacted by a given resource option or resource plan. These, and other, factors are discussed later in this chapter in section III.C.

Step 4: Finalizing FPL's Current Resource Plan

The results of the previous three fundamental steps are typically used to develop the current resource plan. This plan is presented in the following section.

III.B Projected Incremental Resource Additions/Changes

FPL's projected incremental generation capacity additions/changes for 2013 through 2022 are depicted in Table III.B.1. These capacity additions/changes result from a variety of actions that primarily consist of: (i) changes to existing units (which are frequently achieved as a result of plant component replacements during major overhauls and through other uprates to existing capacity), (ii) changes in the amounts of purchased power being delivered under existing contracts as per the contract schedules or by entering into new purchase contracts, (iii) the modernizations of FPL's existing Cape Canaveral, Riviera Beach, and Port Everglades sites by the removal of the steam

generating units that were previously, or are currently, on the sites and the addition of one new, very fuel-efficient CC generating unit at each site, (iv) upgrades to the CTs at a number of existing combined cycle plants, (v) the switching of Turkey Point 1 and 2 from generation to synchronous condenser operation, and (vi) the addition of the new Turkey Point Unit 6 nuclear unit in 2022 (i.e., the year currently projected at the time this document is being finalized to be the earliest practical in-service date for this new nuclear unit).

Although the DSM additions that are consistent with the FPSC's directions regarding FPL's DSM program implementation are not explicitly presented in this table, these DSM additions have been fully accounted for in all of FPL's resource planning work reflected in this document. The FPSC's directions regarding FPL's DSM program implementation address the years through 2019. For planning purposes in this document, FPL currently projects an additional 100 MW (Summer) of DSM per year for the subsequent three years (2020 through 2022) addressed in this Site Plan. In addition, the projected MW reductions from these DSM additions are reflected in the projected reserve margin values shown in the table below and in Schedules 7.1 and 7.2 presented later in this chapter. (Subsequent analyses, particularly analyses that will be conducted in preparation for the 2014 DSM Goals docket, will ultimately determine the actual levels of DSM that FPL should implement in the 2015 through 2022 time frame.)

Table III.B.1: Projected Capacity Changes for FPL

<i>Projected Capacity Changes for FPL ⁽¹⁾</i>			
<i>Year</i>	<i>Projected Capacity Changes</i>	<i>Net Capacity Changes (MW)</i>	
		<i>Winter ⁽²⁾</i>	<i>Summer ⁽³⁾</i>
2013	Changes to Existing Purchases ⁽⁴⁾	(545)	(425)
	Port Everglades Units 3 & 4 retired for Modernization	(765)	(761)
	Turkey Point Unit 2 operation changed to synchronous condenser	(394)	(392)
	Sanford Unit 5 CT Upgrade	—	9
	Turkey Point Unit 4 Uprate - Completed	—	115
	Turkey Point Unit 4 Uprate - Outage ⁽⁵⁾	(717)	—
	Sanford Unit 4 CT Upgrade	—	16
	Manatee Unit 2	(3)	—
	Scherer Unit 4	(28)	—
	Cape Canaveral Next Generation Clean Energy Center ⁽⁶⁾	—	1,210
	Manatee Unit 1 ESP - Outage ⁽⁷⁾	(822)	—
	Martin Unit 1 ESP - Outage ⁽⁷⁾	—	(826)
	Sanford Unit 5 CT Upgrade	19	10
2014	Cape Canaveral Next Generation Clean Energy Center ⁽⁶⁾	1,355	—
	Changes to Existing Purchases ⁽⁴⁾	22	37
	Manatee Unit 1 ESP - Outage ⁽⁷⁾	822	—
	Sanford Unit 4 CT Upgrade	16	—
	Vero Beach Combined Cycle ⁽⁸⁾	46	44
	Martin Unit 1 ESP - Outage ⁽⁷⁾	(832)	826
	Martin Unit 2 ESP - Outage ⁽⁷⁾	—	(826)
	Manatee Unit 3 CT Upgrade	—	19
	Turkey Point Unit 5 CT Upgrade	—	33
	Turkey Point Unit 4 Uprate - Completed ⁽⁵⁾	115	—
	Riviera Beach Next Generation Clean Energy Center ⁽⁶⁾	—	1,212
	Manatee Unit 3 CT Upgrade	39	20
	2015	Martin Unit 1 ESP - Outage ⁽⁷⁾	832
Martin Unit 2 ESP - Outage ⁽⁷⁾		—	826
Turkey Point Unit 5 CT Upgrade		33	—
Changes to Existing Purchases ⁽⁴⁾		70	70
Ft. Myers Unit 2 CT Upgrade		—	51
Riviera Beach Next Generation Clean Energy Center ⁽⁶⁾		1,344	—
2016	Changes to Existing Purchases ⁽⁴⁾	(858)	(928)
	Ft. Myers Unit 2 CT Upgrade	51	—
	Port Everglades Next Generation Clean Energy Center ⁽⁶⁾	—	1,277
2017	Turkey Point Unit 1 operation changed to synchronous condenser	(398)	(396)
	Changes to Existing Purchases ⁽⁴⁾	(37)	(37)
	Vero Beach Combined Cycle ⁽⁸⁾	(46)	(44)
	Port Everglades Next Generation Clean Energy Center ⁽⁶⁾	1,429	—
2018	Changes to Existing Purchases ⁽⁴⁾	(388)	(381)
2019	—	—	—
2020	—	—	—
2021	Changes to Existing Purchases ⁽⁴⁾	180	180
2022	Turkey Point Nuclear Unit 6 ⁽⁶⁾	—	1,100

(1) Additional information about these resulting reserve margins and capacity changes are found on Schedules 7 & 8 respectively.
(2) Winter values are forecasted values for January of the year shown.
(3) Summer values are forecasted values for August of the year shown.
(4) These are firm capacity and energy contracts with QF, utilities, and other entities. See Table I.B.1 and Table I.B.2 for more details.
(5) Outages for uprate work.
(6) All new unit additions are scheduled to be in-service in June of the year shown. All additions assumed to start in June are included in the Summer reserve margin calculation starting in that year and in the Winter reserve margin calculation starting with the next year.
(7) Outages for ESP work.
(8) This unit will be added as part of the agreement that FPL will serve Vero Beach's electric load starting January, 2014. This unit is expected to be retired within 3 years.

III.C Discussion of the Projected Resource Plan and Issues Impacting FPL's Resource Planning Work

As indicated in the Executive Summary, FPL's resource planning efforts in 2012 and early 2013 were influenced by a number of factors. These factors are expected to continue to influence FPL's resource planning work for the foreseeable future. In addition, other factors may also influence FPL's on-going resource planning work in the future and may result in changes to the resource plan discussed in this document. Eight (8) of these factors are discussed below (in no particular order of importance).

- 1) Maintaining/enhancing fuel diversity in the FPL system;
- 2) Maintaining a balance between load and generating capacity in Southeastern Florida, particularly in Miami-Dade and Broward Counties;
- 3) FPL will begin to provide electric service to Vero Beach;
- 4) The projected impacts of mandated energy efficiency standards;
- 5) FPL's growing dependence upon DSM resources to maintain system reliability;
- 6) The Nuclear Regulatory Commission's schedule for reviewing applications for Combined Operating Licenses for new nuclear units;
- 7) Environmental regulation and/or legislation; and,
- 8) Possible establishment of "Clean Energy Standards" or another mechanism to promote large scale utilization of renewable energy.

These 8 factors, and their various impacts on FPL's resource planning efforts including the current resource plan that is presented in this Site Plan, are briefly discussed below.

1. Maintaining/Enhancing System Fuel Diversity;

FPL is currently dependent upon using natural gas to generate approximately 2/3 of the total electricity it delivers to its customers. In the future, the percentage of FPL's electricity that is generated by natural gas is projected to increase. Therefore, FPL is continually seeking opportunities to maintain and enhance the fuel diversity of its system.

In 2007, following express direction by the Commission to do so, FPL sought approval from the FPSC to add two new advanced technology coal units to its system. These two new units would have been placed in-service in 2013 and 2014. However, in part due to concerns over potential greenhouse gas emission

legislation/regulation, FPL was unable to obtain approval for these units. Several other factors are currently unfavorable to new coal units compared to new CC units. The first of these factors is a significant reduction in the fuel cost difference between coal and natural gas compared to the fuel cost difference projected in 2007 that favored coal; i.e., the projected cost advantage of coal versus natural gas has been significantly reduced. Second is the continuation of significantly higher capital costs for coal units compared to capital costs for CC units. Third is the increased fuel efficiency of new CC units compared to projected CC unit efficiencies in 2007. Fourth are the stricter environmental regulations, and the possibility of other environmental regulations that address greenhouse gas emissions, that are more unfavorable to new coal units than to new CC units. Consequently, FPL does not believe that new advanced technology coal units are currently economically, politically, or environmentally viable fuel diversity enhancement options in Florida.

Therefore, FPL has turned its attention to nuclear energy and renewable energy to enhance its fuel diversity and to using natural gas more efficiently. In regard to nuclear energy, in 2008 the FPSC approved the need to increase capacity at FPL's four existing nuclear units and authorized FPL to recover project-related expenditures that are approved as a result of annual nuclear cost recovery filings. In April of this year FPL will have completed this Extended Power Uprate (EPU) project and more than 500 MW of additional nuclear capacity will have been achieved to benefit FPL's customers.⁵

FPL is continuing its work to obtain all of the licenses, permits, and approvals that would be necessary to construct and operate two new nuclear units at its Turkey Point site in the future. These licenses, permits, and approvals will provide FPL with the opportunity to construct these nuclear units at Turkey Point for a time expected to be up to 20 years from the time the licenses and permits are granted, and then to operate the units for at least 40 years thereafter. At the time this document is being finalized, the earliest practical deployment date for the first of the two new nuclear units, Turkey Point Unit 6, is projected to be 2022.

FPL also has been involved in activities to investigate adding or maintaining renewable resources as a part of its generation supply. One of these activities is a

⁵ The value for the increased capacity delivered by the EPU project will be known once the final testing at all of the four nuclear units is completed. At the time this document was being finalized, this testing had not yet been completed. However, for resource planning analysis purposes, a specific MW value is needed for calculations. For these analysis purposes, FPL is assuming the EPU project will have delivered a nominal 510 MW which equates to approximately 501 MW Summer and 516 MW Winter.

variety of discussions with the owners of existing facilities aimed at maintaining or extending current agreements that are scheduled to end during the ten-year reporting period of this document. As previously mentioned, FPL has recently signed power purchase agreements with EcoGen that will result in FPL receiving 180 MW of firm capacity from biomass facilities beginning in 2021.

FPL also sought and received approval from the FPSC in 2008 to add 110 MW through three new FPL-owned solar facilities: one solar thermal facility and two photovoltaic (PV) facilities. One 25 MW PV facility began commercial operation in 2009. The remaining two solar facilities, a 10 MW PV facility and a 75 MW solar thermal steam generating facility, began commercial operation in 2010. The addition of these renewable energy facilities was made possible due to enabling legislation from the Florida Legislature in 2008. FPL remains strongly supportive of Federal and/or State legislation that enables electric utilities to add renewable energy resources and authorize the utilities to recover appropriate costs for these resources.

In regard to using natural gas more efficiently, FPL received approvals in 2008 from the FPSC to modernize the existing Cape Canaveral and Riviera Beach plant sites with new, highly efficient CC units that replace the former steam generating units on each of those sites. The modernizations of Cape Canaveral and Riviera Beach are currently underway and are projected to go in-service on time in mid-2013 and mid-2014, respectively. On April 9th, 2012, FPL received FPSC approval to proceed with a similar modernization project at the Port Everglades site which is scheduled for completion in mid-2016. The modernization of Port Everglades will retain the capability of receiving water-borne delivery of oil as a backup fuel.

In regard to natural gas delivery, FPL issued a request for proposals (RFP) in December 2012 for new natural gas pipeline capacity into Florida and FPL's service territory. A third pipeline utilizing a new route would result in a more reliable, more economic, and more diverse natural gas supply for FPL's customers and the state of Florida. Proposals to this RFP are due in early April 2013.

In the future, FPL will continue to identify and evaluate alternatives that may maintain or enhance system fuel diversity. Moreover, FPL is also maintaining the ability to utilize fuel oil at existing units that have that capability. In this regard, FPL is in the process of installing electrostatic precipitators (ESPs) at its four 800 MW steam generating units at the Martin and Manatee sites which will enable FPL to retain the ability to burn oil, as needed, at these sites while retaining the flexibility to use natural gas when economically attractive.

2. Maintaining a Balance Between Load and Generation in Southeastern Florida:

In recent years, an imbalance was projected to develop between regionally installed generation and regional peak load in Southeastern Florida. With such an imbalance, a significant amount of energy required in the Southeastern Florida region during peak periods would need to be provided either by operating less efficient generating units located in Southeastern Florida out of economic dispatch, or by importing the energy through the transmission system from plants located outside the region. FPL's prior planning work concluded that either additional installed generating capacity in this region, or additional installed transmission capacity capable of delivering more electricity from outside the region, would be required to address this imbalance.

Partly because of the lower transmission-related costs resulting from their location, four recent capacity addition decisions (Turkey Point Unit 5 and WCEC Units 1, 2, & 3) were determined to be the most cost-effective options to meet FPL's capacity needs in the near-term. In addition, FPL has added increased capacity at FPL's existing two nuclear units at Turkey Point as part of the previously mentioned EPU project. The recently approved Port Everglades modernization project scheduled for completion in 2016 will also significantly aid in mitigating this imbalance. Adding the additional generation capacity through the projects mentioned above contributes to addressing the imbalance between generation and load in Southeastern Florida for approximately the remainder of this decade.

The planned addition of two new nuclear units at FPL's Turkey Point site, Turkey Point Unit 6 in 2022 and Turkey Point Unit 7 in 2023, will also address the imbalance issue for an additional period of time beginning in the next decade. Due to steadily increasing load in the Southeastern region, the Southeastern Florida imbalance issue will remain an important consideration in FPL's on-going resource planning work in future years.

3. FPL Will Begin to Provide Electric Service to Vero Beach:

FPL will begin serving Vero Beach's electrical load beginning January 1, 2014. An agreement to this effect was reached between Vero Beach and FPL on February 19, 2013, and a referendum was held on March 12, 2013 resulted in a majority of Vero Beach voters approving the agreement. The additional peak load that FPL will serve is projected to be 155 MW (Summer) in 2014 with additional growth in this peak load expected thereafter.

4. The Impacts of Mandated Energy Efficiency Standards:

Recent increases in the level of federal- and state-mandated energy efficiency standards for appliances, lighting, and other electric equipment began in 2005 with the passage of the National Energy Policy Act. These mandated efficiency standards have been periodically raised and extended since that time. FPL accounts for the impacts of these efficiency standards on projected peak load and annual energy usage in its load forecast.

The magnitude of efficiency that is being delivered to FPL's customers through these standards is significant. For example, by the year 2022, the cumulative impact of these standards since 2005 is expected to result in a reduction in FPL's Summer peak of approximately 2,900 MW compared to what the projected load would have been without the efficiency standards. This represents a decrease of approximately 10% in the forecasted Summer peak load for 2022. Likewise, FPL's forecasted net energy for load (NEL) in the year 2022 is projected to be approximately 11,850 GWh lower compared to what the projected NEL would have been without the efficiency standards. This represents a decrease of approximately 8% in the forecasted NEL for 2022.

In addition to lowering FPL's forecast from what it otherwise would have been, and thus lowering FPL's projected resource needs, this projection of increased efficiency from the efficiency standards also affects FPL's resource planning in another way. The mandated higher efficiency standards lower the potential for future MW and GWh reductions from FPL's demand side management (DSM) programs that address the specific appliances and equipment covered by the standards. FPL will take this fact into consideration in the aspects of its resource planning work that

involve consideration of both the magnitude and type of DSM resources in its DSM portfolio.

5. FPL's Increasing Dependence On DSM Resources to Maintain System Reliability:

With its 2013 Site Plan, FPL continues to project that it will become increasingly dependent upon DSM resources to maintain system reliability. This projected trend has been previously discussed in FPL's 2011 and 2012 Site Plans. This trend is largely a result of two things: (1) high levels of DSM implementation by FPL required by the FPSC, and (2) relatively low growth in forecasted load.⁶

In regard to these two factors, in late 2009 the FPSC imposed significantly higher 10-year DSM Goals than had been deemed appropriate in previous DSM Goals dockets. For example, the 2009 Goals level was set at approximately 150 MW per year, almost double the previous 2004 Goals level of approximately 80 MW per year. The FPSC's 2011 DSM Plan decision subsequently lowered these required levels of DSM, but only by a relatively small amount to approximately 120-to-130 MW per year. As a consequence, FPL's resource planning is projecting DSM implementation of approximately 120-to-130 MW per year through the year 2019. During this time frame, FPL's projected load growth is considerably lower than the load growth projected when the 2004 Goals target of approximately 80 MW per year was set.

Consequently, DSM growth is projected to continue at a high level while FPL's projected load growth has slowed. As a result, the FPL system is becoming increasingly dependent upon DSM to maintain system reliability.

In its 2011 and 2012 Site Plans, FPL discussed this projected trend of increasing dependence upon DSM resources using a new type of reserve margin projection as an indicator: a "generation-only reserve margin" (gen-only RM). In calculating the values for this indicator, all of FPL's projected incremental load management and energy efficiency program capabilities, and its existing load management capability, are removed from the reserve margin calculation.

⁶ Other contributing factors include the expiration of existing PPAs such as UPSR, the effective expiration of the SJRPP PPA, and the retirement of several older FPL generating units for economic reasons.

The resulting gen-only RM values indicate what FPL's reserve margin values are projected to be based solely on generation resources. The lower the gen-only RM values, the greater FPL's dependence is upon DSM resources.

The gen-only RM projections from the 2011 and 2012 Site Plans were presented in Schedules 7.3 and 7.4 in those Site Plans. These schedules consistently showed that FPL's gen-only RM values were projected to significantly decrease throughout the 10-year reporting period of those Site Plans, and to decline to single-digit values in the latter years of the reporting periods. These projections indicate a steadily growing dependence on DSM resources to maintain system reliability. Schedule 7.3 in this year's Site Plan, presented near the back of this chapter, shows a similar projection. FPL's gen-only RM is projected to be in the general range of 16.3% to 18.0% for the period of 2013 through 2016, then decrease steadily until 2021 when the projected gen-only RM value is 6.9%. In 2022, the projected gen-only RM value is 4.7% if potential delays (see discussion below) preclude FPL from bringing Turkey Point Unit 6 into service as currently planned in 2022. Schedule 7.4 presents the projection of FPL's gen-only RM after accounting for the planned addition of Turkey Point Unit 6 in 2022. This addition increases the projected gen-only RM value to 8.9%.

These consistent projections of increasing dependence on DSM resources to maintain system reliability are of concern to FPL because of the various voluntary aspects associated with customer participation in DSM programs, FPL believes that system reliability risk increases as dependence on DSM resources increases. Therefore, this issue will continue to be analyzed in FPL's on-going resource planning work.

6. The Nuclear Regulatory Commission's Schedule for Review of Applications for New Nuclear Units:

As the 2013 Site Plan is being finalized, it is unclear when the Nuclear Regulatory Commission (NRC) will issue a new schedule for its review of FPL's application for a Combined Operating License (COL) for the Turkey Point Units 6 & 7 nuclear units and the potential impact that revised schedule may have on the overall project schedule. FPL will require a Combined Operating License (COL) from the Nuclear Regulatory Commission (NRC) before construction of the two new nuclear units planned for the Turkey Point site. During 2012, the NRC placed several review

schedules "under review", including FPL's COL application. At the time this Site Plan is being finalized, the NRC has not identified a date by which it will issue a new schedule. Once the NRC's new review schedule is issued, FPL will conduct a project schedule review, integrating this information with other relevant information, to determine earliest practicable in-service date for Turkey Point Unit 6.

7. Environmental Regulation and/or Legislation:

As developments occur in regard to new environmental regulations and/or laws, and in how current environmental regulations/laws are interpreted and applied, the potential exists for changes to occur in FPL's resource plan that is presented in this document. For example, FPL has become aware of potential impacts to generating units of recent EPA changes to the National Ambient Air Quality Standards that include shorter duration 1-hour standards for NO₂ and SO₂. FPL has begun the process of evaluating the impact of these standards on the fossil generating fleet, especially the higher emitting peaking gas turbines that have short emission stacks. The results of this analysis could potentially change FPL's resource plan information that is contained in this document.

8. Possible Establishment of "Clean Energy Standards":

Another factor that could influence FPL's resource planning, and could result in changes to the resource plan presented in this Site Plan, is the possibility of the establishment of a Florida standard for renewable energy or clean energy. A Renewable Portfolio Standard (RPS) proposal was prepared by the FPSC, and then sent to the Florida Legislature for consideration, with a possible change to a Clean Portfolio Standard (CPS), during the 2009 legislative session. However, no RPS or CPS legislation was enacted in that session or in subsequent legislative sessions. Furthermore, during the 2012 legislative session, the legislature deleted a now obsolete directive to the FPSC that had instructed them to adopt RPS rules. RPS or CPS legislation, or other legislative initiatives regarding renewable or clean energy contributions, may still occur in the future at either the state or national level. If such legislation is enacted in later years, FPL would then determine what steps need to be taken to address the legislation. Such steps would then be discussed in FPL's Site Plan in the year following the enactment of such legislation.

III.D Demand Side Management (DSM)

FPL has sought out and implemented cost-effective DSM programs since 1978. These programs include both conservation initiatives and load management. FPL's DSM efforts through 2012 have resulted in a cumulative Summer peak reduction of approximately 4,652 MW (Summer) at the generator and an estimated cumulative energy saving of approximately 62,653 Gigawatt Hour (GWh) at the generator. After accounting for reserve margin requirements, FPL's DSM efforts through 2012 have eliminated the need to construct the equivalent of approximately 14 new 400 MW generating units.

FPL has consistently been among the leading utilities nationally in DSM achievement. For example, according to the U.S. Department of Energy's 2011 data (the last year for which the DOE data was available at the time this Site Plan is being developed), FPL ranked # 2 nationally in cumulative DSM demand reduction. And, importantly, FPL has achieved these significant DSM accomplishments while seeking to lessen the DSM-based impact on electric rates for all of its customers.

During 2012 and early 2013, FPL offered the following DSM programs to its customers:

Residential DSM Programs

1. **Air-Conditioning**: This program is designed to reduce energy consumption and growth of coincident peak demand by encouraging customers to install high-efficiency central air-conditioning systems.
2. **Load Management (On Call)**: This program is designed to reduce the Summer and Winter coincident peak demand and energy by turning off customers' appliances for varying durations. Load control equipment is installed at selected customer end-use equipment, allowing FPL to control these loads. Qualifying equipment includes central electric air conditioners, central electric heaters, conventional electric water heaters, and swimming pool pumps.
3. **Building Envelope**: This program is designed to reduce energy consumption and growth of coincident peak demand by encouraging customers to improve the thermal efficiency of the building structure.
4. **New Construction (BuildSmart®)**: This program is designed to reduce energy consumption and growth of coincident peak demand through the design and

construction of energy-efficient homes. The program encourages builders and developers to achieve the ENERGY STAR® qualification.

5. **Duct System Testing and Repair:** This program is designed to reduce energy consumption and growth of coincident peak demand by encouraging customers to repair air leaks identified in air-conditioning duct systems.
6. **Low Income Weatherization:** This program is designed to reduce energy consumption and growth of coincident peak demand by partnering with government and non-profit agencies to assist eligible low income FPL residential customers to reduce the cost of heating and cooling their homes. The agencies include weatherization agency providers (WAPS), non-weatherization agency providers (non-WAPS), and other providers approved by FPL. The rebates are used by these providers to leverage their funds to increase the overall energy efficiency of the homes they are retrofitting.
7. **Home Energy Survey:** This program is designed to reduce energy consumption and growth of coincident peak demand by offering home energy surveys to customers. This objective is accomplished by educating customers on energy efficiency and encouraging customers to perform recommended practices and measures, even if they are not included in FPL's DSM Plan. The energy survey is also used to identify customers for other residential rebate programs dependent upon survey findings. (Note, FPL does not count demand and energy savings from this program towards achieving its DSM Goals.)

Business DSM Programs

1. **Heating, Ventilating, and Air Conditioning (HVAC):** This program is designed to reduce energy consumption and growth of coincident peak demand by encouraging customers to install high-efficiency HVAC systems. The current FPL program includes rebates for: 1) thermal storage; 2) chillers; 3) energy recovery ventilator units; 4) direct expansion (DX) units and efficient air conditioning room units; 5) demand control ventilation systems including kitchen hood control; and 6) electrically commutated motors for air conditioning systems.
2. **Commercial Industrial Demand Reduction (CDR):** This program is designed to reduce the growth of coincident peak demand by controlling customer loads of 200 kW or greater during periods of extreme demand, capacity shortages, or system emergencies.

3. **Commercial/Industrial Load Control (CILC)**: This program is designed to reduce the growth of coincident peak demand by controlling customer loads of 200 kW or greater during periods of extreme demand, capacity shortages, or system emergencies. This program was closed to new participants as of December 31, 2000,
4. **Building Envelope**: This program is designed to reduce energy consumption and growth of coincident peak demand by encouraging customers to install eligible building envelope measures (e.g., roof/ceiling insulation, reflective roof coatings and window treatments).
5. **Business On Call**: This program is designed to reduce the summer coincident peak demand and energy by turning off customers' direct expansion central electric air-conditioning units.
6. **Efficient Lighting**: This program is designed to reduce energy consumption and growth of coincident peak demand by encouraging customers to install high-efficiency lighting systems.
7. **Business Custom Incentive**: This program is designed to reduce energy consumption and growth of coincident peak demand by encouraging customers to install unique high-efficiency systems not addressed by other FPL DSM programs.
8. **Water Heating**: This program is designed to reduce energy consumption and growth of coincident peak demand by encouraging customers to install high-efficiency water heating systems.
9. **Refrigeration**: This program is designed to reduce energy consumption and growth of coincident peak demand by encouraging customers to install high-efficiency refrigeration systems.
10. **Business Energy Evaluation (BEE)**: This program is designed to reduce energy consumption and growth of coincident peak demand by offering energy audits to business customers. This objective is accomplished by educating customers on energy efficiency and encouraging customers to perform recommended practices and measures, even if these are not addressed by other FPL DSM programs. The BEE is also used to qualify customers for other FPL business rebate programs dependent upon audit findings. (Note, FPL does not count demand or energy savings from this program towards achieving its DSM Goals.)

11. **Cogeneration and Small Power Production:** Facilitates FPL compliance with all regulatory requirements concerning qualifying facilities and small power producers. Assists customers in the evaluation of potential cogeneration projects, including self-generation. (Note, FPL does not count demand or energy savings from this program towards achieving its DSM Goals)

Solar Pilot Programs

1. **Residential Photovoltaic (PV) Pilot:** This pilot is designed to reduce energy consumption and growth of coincident peak demand by encouraging customers to install PV systems in residential homes.
2. **Residential Solar Water Heating Pilot:** This pilot is designed to reduce energy consumption and growth of coincident peak demand by encouraging customers to install solar water heating systems in homes.
3. **Residential Solar Water Heating (Low Income New Construction) Pilot:** This pilot is designed to reduce energy consumption and growth of coincident peak demand, increase the efficiency of low income housing, and demonstrate the practical application of solar water heating in residential new construction by providing solar water heating systems to selected low income housing developments throughout FPL's service territory.
4. **Business Photovoltaic (PV) Pilot:** This pilot is designed to reduce energy consumption and growth of coincident peak demand by encouraging customers to install PV systems in businesses.
5. **Business Photovoltaic (PV) for Schools Pilot:** This pilot is designed to reduce energy consumption and growth of coincident peak demand and demonstrate and educate future generations on the practical applications of PV by providing PV systems and educational materials for selected schools in all public school districts throughout FPL's service territory.
6. **Business Solar Water Heating Pilot:** This pilot is designed to reduce energy consumption and growth of coincident peak demand by encouraging customers to install solar water heating systems in businesses.

DSM Research and Development:

Conservation Research and Development (CRD): CRD is an umbrella research project under which potential new DSM technologies are analyzed. Several FPL DSM programs have emerged from the CRD project including Business Building Envelope, Business On Call, and Residential New Construction (BuildSmart®) programs. This project has also resulted in the addition of cost-effective measures to existing programs, such as the inclusion of Energy Recovery Ventilators to the Business HVAC Program.

DSM Goals:

The FPSC in late 2009 imposed significantly higher DSM Goals for FPL for 2010 – 2019 than were deemed appropriate in prior DSM Goals dockets. The DSM Goals imposed by the FPSC have three components: Summer MW reductions, Winter MW reductions, and GWh reductions. The Summer MW component, and to a much lesser degree the Winter MW reduction component, impacts FPL's need for future resources such as those discussed in this document. The GWh reduction component has no impact on FPL's need for future resources.

In 2011, based on concerns over the projected higher electric rates that would result if a new DSM Plan to meet the new 2009 DSM Goals were implemented, the FPSC instructed FPL to continue executing its currently existing DSM programs (FPSC Order PSC-11-0590-FOF-EG). The projected demand reduction impact of these DSM programs from 2013 through 2019, plus an assumed additional 100 MW per calendar year for 2020 through 2022, is presented below in Table III.D.1. (Subsequent analyses will ultimately determine the actual levels of DSM that should be added in these later years.)

Table III.D.1: FPL's Projected DSM Summer MW Reduction for 2013 - 2022

August MW values (at the Generator)

Year	Cumulative Summer DSM MW for FPL (at Generator)
2013	124
2014	243
2015	369
2016	494
2017	619
2018	745
2019	870
2020	970
2021	1,070
2022	1,170

FPL's intent is to follow the FPSC's directions regarding DSM implementation and to continue its national leadership role in DSM. In doing so, FPL will maintain focus on lessening the DSM-based impact on electric rates for all of FPL's customers and ensuring that FPL's system reliability does not become too dependent upon DSM resources.

III.E Transmission Plan

The transmission plan will allow for the reliable delivery of the required capacity and energy to FPL's retail and wholesale customers. The following table presents FPL's proposed future additions of 230 kV bulk transmission lines that must be certified under the Transmission Line Siting Act.

Table III.E.1: List of Proposed Power Lines

(1) Line Ownership	(2) Terminals (To)	(3) Terminals (From)	(4) Line Length CKT. Miles	(5) Commercial In-Service Date (Mo/Yr)	(6) Nominal Voltage (KV)	(7) Capacity (MVA)
FPL	St. Johns ^{1/}	Pringle	25	Dec – 17	230	759
FPL	Manatee ^{2/}	Bob White	30	Dec – 14	230	1195

1/ Final order certifying the corridor was issued on April 21, 2006. This project is to be completed in two phases. Phase I consisted of 4 miles of new 230 kV line (Pringle to Pellicer) and was completed in May-2009. Phase II consists of 21 miles of new 230 kV line (St. Johns to Pellicer) and is scheduled to be completed by Dec-2017.

2/ Final order certifying the corridor was issued on November 6, 2008. This project consists of 30 miles of new 230 kV line (Manatee to Bob White) and is scheduled to be completed by Dec-2014

In addition, there will be transmission facilities needed to connect several of FPL's projected generating capacity additions to the system transmission grid. These transmission facilities (described on the following pages) are for the remaining capacity increase (uprate) at the existing Turkey Point Unit 4 nuclear generating unit, the generating capacity additions with the Cape Canaveral, Riviera Beach and Port Everglades modernizations, and the planned new nuclear capacity addition at the Turkey Point site from Turkey Point Unit 6.

III.E.1 Transmission Facilities for Turkey Point Unit 4 Capacity Uprate

The work that was required to address the remainder of the Turkey Point Unit 4 uprate in 2013 in regard to the FPL grid consisted of the following:

I. Substation:

1. At Turkey Point Switchyard, install two 5-Ohm series phase inductors combined with external shunt capacitors on the southeast and southwest 230 kV operating busses.
2. At Turkey Point Switchyard, replace twelve 230 kV disconnect switches. Also upgrade associated jumpers, bus work and equipment connections.
3. Uprate the Unit 4 main step-up transformer to 970 MVA.
4. Replace spare main step-up transformer with 1028 MVA transformer.
5. Add relays and other protective equipment.
6. Replace breaker failure panels at Davis Substation.
7. Replace breaker failure panels at Flagami Substation.

II. Transmission:

1. Upgrade the existing string busses for Unit 4 between the main step-up transformer and the switchyard with spacers between the conductors.

III.E.2 Transmission Facilities for Cape Canaveral Next Generation Clean Energy Center (Modernization)

The work required to connect the Cape Canaveral Next Generation Clean Energy Center in 2013 to the FPL grid is as follows:

I. Substation:

1. Build new collector yard containing two collector busses with four breakers to connect the three combustion turbines (CT), and one steam turbine (ST).
2. Construct two string busses to connect the collector busses to Cape Canaveral 230 kV Substation.
3. Add four main step-up transformers (3-370 MVA, 1- 580 MVA), one for each CT, and one for the ST.
4. At Cape Canaveral Switchyard replace eight 230 kV disconnect switches. Also upgrade associated jumpers, bus work and equipment connections.
5. Expand switchyard relay vault and add relays and other protective equipment.

II. Transmission:

1. Relocate the Cape Canaveral-Grissom 115 kV line.

III.E.3 Transmission Facilities for Riviera Beach Next Generation Clean Energy Center (Modernization)

The work required to connect the Riviera Beach Next Generation Clean Energy Center in 2014 to the FPL grid is as follows:

I. Substation:

1. Expand the Riviera Beach 230 kV Switchyard five breakers to accommodate terminals for one combustion turbine (CT), and one steam turbine (ST).
2. Construct a new 138 kV Riviera Beach Switchyard - five bays, 14 breakers with terminals to connect two CT units and seven 138 kV lines.
3. Add four main step-up transformers (3-370 MVA, 1- 580 MVA), one for each CT, and one for the ST.
4. Add relays and other protective equipment.
5. At Ranch Substation, add a new 230 kV bay 5 and upgrade bay 4 to 3000 Amperes.
6. At Sugar Substation, install one set of 2.5 Ohm phase inductors on the Corbett-Sugar 230 kV line.
7. Breaker replacements:
 - Ranch Substation – Replace one 230 kV breaker
 - Broward Substation – Replace one 230 kV breaker

II. Transmission:

1. Break the Indiantown-Riviera Beach 230 kV and extend each of the line segments south (approx. 4 miles) to connect to the Ranch 230 kV Substation forming Indiantown-Ranch and a Ranch-Riviera Beach 230 kV circuits.
2. Remove Corbett-Ranch #2 230 kV line at Ranch and:
 - a. extend to meet the Cedar-Lauderdale 230 kV line N/S corridor (approx. 10 miles).
3. Break Cedar-Corbett 230 kV (near Ranch Sub in Corbett-Jog section) and:
 - a. Extend Cedar side to Riviera Beach, (approx. 15 miles) creating new Cedar-Riviera Beach 230 kV.
 - b. Extend Corbett side to meet the Cedar-Lauderdale 230 kV N/S corridor (approx. 10 miles).
4. Break Cedar-Lauderdale 230 kV (near 230 corridor running N/S)
 - a. Connect Cedar side to meet 3.b. to create a Cedar to Corbett 230 kV.
 - b. Connect Lauderdale side to meet 2.a. to create a Corbett to Lauderdale 230 kV.
5. Upgrade the existing IBM-Yamato 138 kV line to 1200 Amperes.

6. New underground 138 kV tie line between new Riviera Beach 138 kV Switchyard and 560 MVA, 230/138 kV autotransformer in the expanded Riviera Beach 230 kV Substation.
7. Relocate six existing 138 kV lines from existing Riviera Beach 138 kV Switchyard to new Riviera Beach 138 kV Switchyard.

III.E.4 Transmission Facilities for Port Everglades Next Generation Clean Energy Center (Modernization)

The work required to connect the Port Everglades Next Generation Clean Energy Center in 2016 to the FPL grid is projected to be:

I. Substation:

1. Construct two string busses to connect two combustion turbines (CT) to the Port Everglades 138 kV Substation.
2. Construct two string busses to connect one CT, and one steam turbine (ST) to the Port Everglades 230 kV Substation.
3. Add four main step-up transformers (3-450 MVA, 1- 580 MVA), one for each CT, and one for the ST.
4. Replace ten (10) 138 kV breakers
5. Replace eight (8) 230 kV breakers
6. At Port Everglades Switchyard replace twenty-two 138 kV disconnect switches. Also upgrade associated jumpers, bus work, and equipment connections.
7. Expand switchyard relay vault and add relays and other protective equipment.

II. Transmission:

1. Upgrade of existing transmission facilities:
 - An ampacity upgrade up to 1905 amps on the Port Everglades-Port Everglades Tap 138kV line section.
 - An ampacity upgrade up to 1905 amps on the Port Everglades Tap-Port Everglades Tap 2 138 kV line section.
 - An ampacity upgrade up to 1695 amps on the Port Everglades Tap 1-Dania 138 kV line section.
 - An ampacity upgrade up to 1695 amps on the Dania-Hollywood 138 kV line section.

III.E.5 Transmission Facilities for Turkey Point Nuclear Unit 6

The work required to connect the Turkey Point Nuclear Unit 6 by Summer 2022 to the FPL grid is projected to be:

I. Substation:

1. Build new Clear Sky 500/230kV Switchyard with six (6) bays on the 230 kV section for generator main step-up transformer connection, reserve auxiliary transformer connections, four (4) 230 kV line terminals, two (2) autotransformers and two (2) 500 kV line terminals.
2. At Turkey Point Switchyard add a new bay to accommodate the Turkey Point-Clear Sky 230 kV line terminal.
3. At Gratiigny Substation install a second 230/138 kV autotransformer with one (1) 230 kV breaker and one (1) 138 kV breaker.
4. At Pennsuco Substation install a fourth line terminal to accommodate the Pennsuco-Clear Sky 230 kV line by converting the ring bus to a breaker and a half scheme and adding four (4) 230 kV breakers.
5. At Davis Substation construct two (2) new 230kV line terminals for the Clear Sky-Davis 230 kV line and the Davis-Miami 230 kV line with a switch-able inductor to be installed on the Davis-Miami 230 kV line
6. At Levee Substation expand 500 kV section to accommodate the two (2) Levee-Clear Sky 500 kV lines.
7. At Andytown Substation install two (2) 5-Ohm inductors combined with external shunt capacitors on the 230kV side of the 500/230 autotransformers (one per auto).
8. At Miami Substation expand the 230kV section to a double bus configuration and add a new 230kV line terminal for Davis line and replace one (1) autotransformer.
9. At Flagami Substation install a small inductor on one end of the Flagami-Miami 230kV #2 circuit.
10. Breaker replacements:
 - Flagami Substation – Replace five (5) 230 kV breakers and three (3) 138 kV breakers
 - Miami Substation – Replace one (1) 230 kV breaker and four (4) 138 kV breakers
 - Davis Substation - Replace two (2) 230 kV breakers
 - Dade Substation - Replace seven (7) 230 kV breakers
 - Court Substation – Replace one (1) 138 kV breaker.

II. Transmission:

1. FPL will design and construct two (2) 500kV transmission lines from the new Clear Sky Substation to the existing FPL Levee 500kV Substation switchyard. The lines will be approximately 43 miles long.
2. Construct a new Clear Sky-Davis 230kV line (approximately 19 miles) with a rating of 2990 Amperes.
3. Construct a new Clear Sky-Pennsuco 230kV line (approximately 52 miles) with a rating of 2990 Amperes.
4. Construct a new Davis-Miami 230kV line (approximately 18 miles) with a rating of 2297 Amperes.
5. Construct a new Clear Sky-Turkey Point 230kV line (approximately 0.5 miles) with a rating of 2990 Amperes.

III.F. Renewable Resources

FPL has been the leading Florida utility in examining ways to effectively utilize renewable energy technologies to serve its customers. FPL has been involved since 1976 in renewable energy research and development and in facilitating the implementation of various renewable energy technologies. For purposes of discussing FPL's renewable energy efforts in this document, those efforts will be placed into five categories.

Two of these categories are Supply-Side Efforts – Power Purchases, and Supply-Side Efforts – FPL Facilities. Starting in 2011, the energy (MWh) total output from these renewable energy sources was greater than the energy produced from oil-fired generation. This was also true in 2012. The renewable energy information is presented in Schedule 11.1, and the oil-based energy information is presented in Schedule 6.1. Both of these schedules are presented at the end of this chapter.

1) Early Research & Development Efforts:

FPL assisted the Florida Solar Energy Center (FSEC) in the late 1970s in demonstrating the first residential PV system east of the Mississippi. This PV installation at FSEC's Brevard County location was in operation for over 15 years and provided valuable information about PV performance capabilities in Florida on both a daily and annual basis. FPL later installed a second PV system at the FPL Flagami substation in Miami. This 10-kilowatt (kW) system was placed into operation in 1984. (The system was removed in 1990 at the conclusion of the PV testing to make room for substation expansion.)

For a number of years, FPL maintained a thin-film PV test facility located at the FPL Martin Plant Site. This FPL PV test facility was used to test new thin-film PV technologies and to identify design, equipment, or procedure changes necessary to accommodate direct current electricity from PV facilities into the FPL system. Although this testing has ended, the site became the home for PV capacity which was installed as a result of FPL's earlier "green pricing" efforts.

2) Demand Side & Customer Efforts:

In terms of utilizing renewable energy sources to meet its customers' needs, FPL initiated the first utility-sponsored conservation program in Florida designed to facilitate the implementation of solar technologies by its customers. FPL's Conservation Water Heating Program, first implemented in 1982, offered incentive payments to customers who chose solar water heaters. Before the program ended (due to the fact that it was no longer projected to be cost-effective), FPL paid incentives to approximately 48,000 customers who installed solar water heaters.

In the mid-1980s, FPL introduced another renewable energy program, FPL's Passive Home Program. This program was created in order to broadly disseminate information about passive solar building design techniques which are most applicable in Florida's climate. As part of this program, three Florida architectural firms created complete construction blueprints for six passive home designs with the assistance of the FSEC and FPL. These designs and blueprints were available to customers at a low cost. During its existence, this program was popular and received a U.S. Department of Energy award for innovation. The program was eventually phased out due to a revision of the Florida Model Energy Building Code (Code). This revision was brought about in part by FPL's Passive Home Program. The revision incorporated into the Code was one of the most significant passive design techniques highlighted in the program: radiant barrier insulation.

In early 1991, FPL received approval from the FPSC to conduct a research project to evaluate the feasibility of using small PV systems to directly power residential swimming pool pumps. This research project was completed with mixed results. Some of the performance problems identified in the test were deemed to be solvable, particularly when new pools are constructed. However, the high initial cost of PV, the significant percentage of sites with unacceptable shading, and various customer satisfaction issues remain as significant barriers to wide acceptance and use of this particular solar application.

FPL has since continued to analyze and promote the utilization of PV. These efforts have included PV research, development, and education, as well as development and implementation of the FPL Next Generation Solar Station Program. This initiative also delivers teacher training and curriculum that is tied to the Sunshine Teacher Standards in Florida. Additionally, the program provides teacher grants to promote and fund projects in the classrooms.

In addition, FPL assists customers who are interested in installing PV equipment at their facilities. Consistent with Florida Administrative Code Rule 25-6.065, Interconnection and Net Metering of Customer-Owned Renewable Generation, FPL works with customers to interconnect these customer-owned PV systems. Through December 2012, approximately 2,117 customer systems (predominantly residential) have been interconnected.

As part of its 2009 DSM Goals decision, the FPSC imposed a requirement for Florida's investor-owned utilities to spend up to a set, not-to-exceed amount of money annually to facilitate demand side solar water heater and photovoltaic applications. FPL's not-to-exceed amount of money for these applications is approximately \$15.5 million per year through 2014. In regard to this direction, FPL received approval from the FPSC in 2011 to initiate a solar pilot portfolio that consists of three PV-based programs and three solar water heating-based programs, plus Conservation Research and Development. These programs are currently projected to be offered through 2014. FPL is evaluating the results to-date from these programs.

FPL has also been investigating fuel cell technologies through monitoring of industry trends, discussions with manufacturers, and direct field trials. From 2002 through the end of 2005, FPL conducted field trials and demonstration projects of Proton Exchange Membrane (PEM) fuel cells with the objectives of serving customer end-uses while evaluating the technical performance, reliability, economics, and relative readiness of the PEM technology. The demonstration projects were conducted in partnership with customers and included five locations. The research projects were useful to FPL in identifying specific issues that can occur in field applications and the current commercial viability of this technology. FPL will continue to monitor the progress of these technologies and conduct additional field evaluations as significant developments in fuel cell technologies occur.

3) Supply Side Efforts – Power Purchases:

FPL has also facilitated renewable energy projects (facilities which burn bagasse, waste wood, municipal waste, etc.). Firm capacity and energy, and as-available energy, have been purchased by FPL from these types of facilities. (Please refer to Tables I.B.1, I.B.2, and I.C.1 in Chapter I).

Periodically, FPL invites renewable energy suppliers to provide proposals for renewable power and energy at or below avoided costs in response to FPL's Requests for Proposals (RFPs). FPL issued Renewable RFPs in 2007 and 2008 soliciting proposals to provide firm capacity and energy, and energy only, at or below avoided costs, from renewable generators. FPL also promptly responds to inquiries for information from prospective renewable energy suppliers either by e-mail or phone.

With regard to existing contracts that have recently ended, FPL and the Solid Waste Authority of Palm Beach (SWA) agreed to extend their contract that expired March 31, 2010 for a 20-year term beginning in April 1, 2012 through April 1, 2032. However, the SWA refurbished their generating unit ahead of schedule and, as of January 2012, this unit began delivering firm capacity to FPL. In 2011, the FPSC approved a contract for an additional 70 MW between FPL and SWA for a new unit to be constructed and to begin delivering firm capacity and energy beginning on January 1, 2015. At the end of December 2011, the contract between FPL and Okeelanta (New Hope) expired. However, Okeelanta continues to deliver energy to FPL as an as-available, non-firm supplier of renewable energy.

4) Supply Side Efforts – FPL Facilities:

With regard to solar generating facilities, FPL has three such facilities: (i) a 75 MW steam generation solar thermal facility in Martin County (the Martin Next Generation Solar Energy Center); (ii) a 25 MW PV electric generation facility in DeSoto County (the DeSoto Next Generation Solar Energy Center); and (iii) a 10 MW PV electric generation facility in Brevard County at NASA's Kennedy Space Center (the Space Coast Next Generation Solar Energy Center). The DeSoto County project was completed in 2009 and the other two projects were completed in 2010. These three solar facilities were constructed in response to the Florida Legislature's House Bill 7135 which was signed into law by the Governor in June 2008.

House Bill 7135 was enacted to enable the development of clean, zero greenhouse gas emitting renewable generation in the State of Florida. Specifically, the bill authorized cost recovery for the first 110 MW of eligible renewable projects that had the proper land, zoning, and transmission rights in place. FPL's three solar projects met the specified criteria, and were granted approval for cost recovery in 2008. Each of the three solar facilities is discussed below.

a. **The Martin Next Generation Solar Energy Center:**

This facility began commercial operation in 2010 and provides 75 MW of solar thermal capacity in an innovative way that directly displaces fossil fuel usage on the FPL system. This facility consists of solar thermal technology which generates steam that is integrated into the existing steam cycle for the Martin Unit 8 natural gas-fired CC plant. This project is the first "hybrid" solar plant in the world, and, at the time the facility came in-service, was the second largest solar facility in the world and the largest solar plant of any kind in the U.S. outside of California.

b. **The DeSoto Next Generation Solar Energy Center:**

This PV facility began commercial operation in 2009 and provides 25 MW of non-firm capacity and energy, making it one of the largest PV facilities in the U.S. The facility utilizes a tracking PV array that is designed to follow the sun as it traverses across the sky.

c. **The Space Coast Next Generation Solar Energy Center:**

Located at the Kennedy Space Center, this facility is part of an innovative public/private partnership with NASA. This non-tracking PV facility began commercial operation in 2010 and provides 10 MW of non-firm capacity and energy.

For resource planning purposes, FPL currently projects that the output from these renewable facilities will be "as available," non-firm energy only. This is due to several factors. First, the Martin solar thermal facility is a "fuel-substitute" facility, not a facility that provides additional capacity and energy. The solar thermal facility displaces the use of fossil fuel to produce steam on the FPL system when the solar thermal facility is operating. Second, in regard to the two PV facilities, the intermittent nature of the solar resource makes it difficult to accurately determine what contribution the PV facilities at these specific locations can consistently make at FPL's late Summer

afternoon and early Winter morning peak load hours. Once site-specific operating data has been gathered for an appropriate amount of time, FPL will then re-evaluate the actual output from each PV facility to determine what portion, if any, of its output can be projected as firm capacity at the projected peak hours in FPL's resource planning work.

In addition to these three solar facilities, FPL is currently in the process of identifying other potential solar sites in the state. FPL is evaluating existing FPL generation sites along with potential Greenfield sites within FPL's service territory. These sites are discussed further in Chapter IV.

5) Ongoing Research & Development Efforts:

FPL has developed alliances with several Florida universities to promote development of emerging technologies. For example, an alliance has been established with the newly formed Southeast National Marine Renewable Energy Center (SNMREC) at Florida Atlantic University (FAU), which will focus on the commercialization of ocean current, ocean thermal (i.e., energy conversion as well as cold water air conditioning), and hydrogen technologies. FPL has been taking the lead in assisting FAU with the discussions being held with the U.S. Department of the Interior's Minerals Bureau of Ocean Energy Management Regulation and Enforcement (BOEMRE). BOEMRE is working to establish the permitting process for ocean energy development on the outer continental shelf.

FPL has also developed an alliance with the University of Florida to support its biomass-related studies to determine improved vegetative management techniques for use in minimizing maintenance costs at FPL's current and future solar sites and to perform wind studies within the state. In addition, FPL has partnered with the Florida Institute of Technology on fuel cell technology and with the Florida State Universities Center for Applied Power System in regard to grid integration of ocean energy and other renewables.

FPL has also developed a "Living Lab" to demonstrate FPL's solar energy commitment to employees and visitors at its Juno Beach office facility. To-date, FPL has installed five different PV arrays (different technologies) of rooftop PV totaling 24 kW at the Living Lab. In addition, two PV-covered parking structures with a total of approximately 90 kW of PV were constructed at the FPL Juno office parking lot. Through these Living Lab projects, FPL is able to evaluate multiple solar

technologies and applications for the purpose of developing a renewable business model resulting in the most cost-effective and reliable uses of solar energy for FPL's customers. FPL plans to continue to expand the Living Lab as new solar products come to market.

FPL has also been in discussions with several private companies on multiple emerging technology initiatives including ocean current, ocean thermal, hydrogen, fuel cell technology, biomass, biofuels, and energy storage.

III.G FPL's Fuel Mix and Fuel Price Forecasts

1. FPL's Fuel Mix

Until the mid-1980s, FPL relied primarily on a combination of fuel oil, natural gas, and nuclear energy to generate electricity with significant reliance on oil-fired generation. In the early 1980s, FPL began to purchase "coal-by-wire." In 1987, coal was first added to the fuel mix through FPL's partial ownership (20%) and additional purchases (30%) from the St. Johns River Power Park (SJRPP). This allowed FPL to meet its customers' energy needs with a more diversified mix of energy sources. Additional coal resources were added with the partial acquisition (76%) of Scherer Unit 4 which began serving FPL's customers in 1991. Starting in 1997, petroleum coke was added to the fuel mix as a blend stock with coal at SJRPP when economic.

The trend since the early 1990s has been a steady increase in the amount of natural gas that is used by FPL to provide electricity due, in part, to the introduction of highly efficient and cost-effective CC generating units and the ready availability of natural gas. This planning document reflects an evolution in that trend in recognition that, although efficient gas-fired generation continues to provide significant benefits to FPL's customers, adding natural gas-fired additions exclusively would, in the long term, create an unbalanced generation portfolio. In 2009, FPL placed into commercial operation two new gas-fired CC units at the West County Energy Center (WCEC) site. A third new CC unit was added to the WCEC site in 2011. In addition, FPL is currently modernizing its existing Cape Canaveral, Riviera Beach, and Port Everglades plant sites by removing the steam generating units previously on the sites and replacing them with three highly efficient new CC units, one at each site. These new CC units will provide highly efficient generation that will dramatically improve the efficiency of FPL's generation system in general, and, more specifically, the efficiency at which natural gas is utilized.

In addition, FPL is increasing its utilization of nuclear energy through capacity uprates of its four existing nuclear units. The uprates have been completed at three of the four units, and the uprate work is projected to be completed at the fourth unit at approximately the time this Site Plan is completed. With these uprates, more than 500 MW of additional nuclear capacity have been added to the FPL system. FPL is also pursuing plans to obtain licenses, permits, and approvals to construct and operate two new nuclear units at its existing Turkey Point site that, in total, would add approximately 2,200 MW of new nuclear generating capacity. The earliest date by which the first of these two new nuclear units could practically be deployed is currently projected to be 2022.

In regard to utilizing renewable energy, FPL has added 110 MW of solar generating capacity through a 75 MW solar thermal steam generating facility at FPL's existing Martin site, a 25 MW PV facility in DeSoto County, and a 10 MW PV facility in Brevard County. The DeSoto facility was placed into commercial operation in 2009. The other two solar facilities were placed into commercial operation in 2010.

FPL's future resource planning work will continue to focus on identifying and evaluating alternatives that would most cost-effectively maintain and/or enhance FPL's long-term fuel diversity. These fuel diverse alternatives may include: the purchase of power from renewable energy facilities, additional FPL-owned renewable energy facilities, obtaining additional access to diversified sources of natural gas such as liquefied natural gas (LNG) and natural gas from the Mid-Continent unconventional reserves, preserving FPL's ability to utilize fuel oil at its existing units, and increased utilization of nuclear energy. (As previously discussed, new advanced technology coal generating units are not currently considered as viable options in Florida in the ten-year reporting period of this document due, in part, to current projections of relatively small differences in fuel costs between coal and natural gas, significantly higher capital costs for coal units compared to CC units, greater efficiencies of CC units, and concerns over non-greenhouse gas environmental regulations that would impact coal units more negatively than CC units.) The evaluation of the feasibility and cost-effectiveness of these, and other possible fuel diversity alternatives, will be part of FPL's on-going resource planning efforts.

FPL's current use of various fuels to supply energy to customers, plus a projection of this "fuel mix" through 2022 based on the resource plan presented in this document, is presented in Schedules 5, 6.1, and 6.2 later in this chapter.

FPL's Fossil Fuel Cost Forecasts

Fossil fuel price forecasts, and the resulting projected price differentials between fuels, are major drivers used in evaluating alternatives for meeting future resource needs. FPL's forecasts are generally consistent with other published contemporary forecasts.

Future oil and natural gas prices, and to a lesser extent, coal and petroleum coke prices, are inherently uncertain due to a significant number of unpredictable and uncontrollable drivers that influence the short- and long-term price of oil, natural gas, coal, and petroleum coke. These drivers include U.S. and worldwide demand, production capacity, economic growth, environmental legislation, and politics.

The inherent uncertainty and unpredictability in these factors today and tomorrow clearly underscores the need to develop a set of plausible oil, natural gas, and solid fuel (coal and petroleum coke) price scenarios that will bound a reasonable set of long-term price outcomes. In this light, FPL developed and utilized Low, Medium, and High price forecasts for fossil fuels in some of its 2012 and early 2013 resource planning work, particularly in regard to analyses conducted as part of the nuclear cost recovery filing work.

FPL's Medium price forecast methodology is consistent for oil and natural gas. For oil and natural gas commodity prices, FPL's Medium price forecast applies the following methodology:

- a. For 2013 through 2015, the methodology used the February 4, 2013 forward curve for New York Harbor 1% sulfur heavy oil, U. S. Gulf Coast 1% sulfur heavy oil, ultra low sulfur diesel fuel oil, and Henry Hub natural gas commodity prices;
- b. For the next two years (2016 and 2017), FPL used a 50/50 blend of the February 4, 2013 forward curve and the most current projections at the time from The PIRA Energy Group;
- c. For the 2018 through 2030 period, FPL used the annual projections from The PIRA Energy Group; and,
- d. For the period beyond 2030, FPL used the real rate of escalation from the Energy Information Administration (EIA). In addition to the development of oil and natural gas commodity prices, nominal price forecasts also were

prepared for oil and natural gas transportation costs. The addition of commodity and transportation forecasts resulted in delivered price forecasts.

FPL's Medium price forecast methodology is also consistent for coal and petroleum coke prices. Coal and petroleum coke prices were based upon the following approach:

- a. Delivered price forecasts for Central Appalachian (CAPP), Illinois Basin (IB), Powder River Basin (PRB), and South American coal and petroleum coke were provided by JD Energy; and,
- b. The coal price forecast for SJRPP and Plant Scherer assume the continuation of the existing mine-mouth and transportation contracts until expiration, along with the purchase of spot coal, to meet generation requirements.

The development of FPL's Low and High price forecasts for oil, natural gas, coal, and petroleum coke prices were based on the historical volatility of the 12-month forward price, one year ahead. FPL developed these forecasts to account for the uncertainty which exists within each commodity as well as across commodities. These forecasts reflect a range of reasonable forecast outcomes.

3. Natural Gas Storage

FPL is under contract through March 2013 for 2 billion cubic feet (Bcf) of firm natural gas storage capacity in the Bay Gas storage facility located in Alabama. The Bay Gas storage facility is interconnected with the Florida Gas Transmission (FGT) pipeline. Starting on April 1, 2013, FPL will have entered into a new deal with Bay Gas Storage for one year for 2.5 billion cubic feet (Bcf) of firm natural gas storage capacity. FPL has predominately utilized natural gas storage to help mitigate gas supply problems caused by severe weather and/or infrastructure problems. Over the past several years, FPL has acquired upstream transportation capacity on several pipelines to help mitigate the risk of off-shore supply problems caused by severe weather in the Gulf of Mexico. While this transportation capacity has reduced FPL's off-shore exposure, a portion of FPL's supply portfolio remains tied to off-shore natural gas sources. Therefore, natural gas storage remains an important tool to help mitigate the risk of supply disruptions. For these reasons, FPL has typically maintained nearly full natural gas inventory during normal operations from June through November (hurricane season). From December through March, FPL

typically maintains lower levels of natural gas inventory as compared to Summer peak months.

As FPL's reliance on natural gas has increased, its ability to manage the daily "swings" that can occur on its system due to weather and unit availability changes has become more challenging, particularly from oversupply situations. Natural gas storage is a valuable tool to help manage the daily balancing of supply and demand. From a balancing perspective, injection and withdrawal rights associated with storage have become an increasingly important part of the evaluation of overall storage requirements.

As FPL's system grows to meet customer needs, it must maintain adequate storage capacity to continue to help mitigate supply and/or infrastructure problems and to provide FPL the ability to manage its supply and demand on a daily basis. FPL will continue to evaluate its storage portfolio and enter into arrangements that will help increase reliability, provide the necessary flexibility to respond to demand changes, and diversify the overall portfolio.

4. Securing Additional Natural Gas:

The recent trend of increasing reliance upon natural gas to produce electricity for FPL's customers is projected to continue due to FPL's growing load. The addition of the highly fuel-efficient Cape Canaveral, Riviera Beach, and Port Everglades modernizations will serve to reduce the growth in natural gas use from what it otherwise might have been due to the high fuel-efficiency levels of these new CC units, but these efficiencies do not fully offset the effects of FPL's growing load. Therefore, FPL will need to secure more natural gas supply and more gas transportation capacity. The issue is how to secure these additional natural gas resources in a manner that is economical for FPL's customers and which maintains and/or enhances the reliability of natural gas supply and deliverability to FPL's generating units.

FPL has historically purchased the gas transportation capacity required for new natural gas supply from two existing natural gas pipeline companies. As more natural gas is delivered through these two pipelines, the impact of a supply disruption on either pipeline becomes more problematic. Therefore, FPL issued a Request for Proposals (RFP) in December 2012 for gas transportation capacity to meet FPL's system natural gas requirements beginning in 2017. The RFP encourages bidders to

propose new gas transportation infrastructure to meet Florida's growing need for natural gas. A third pipeline would have benefits for FPL and its customers by increasing the diversity of FPL's fuel supply sources, increasing the physical reliability of the pipeline delivery system, and enhancing competition among pipelines. Responses to this RFP are due in early April 2013.

5. Nuclear Fuel Cost Forecast

This section reviews the various steps needed to fabricate nuclear fuel for delivery to the nuclear power plants, the method used to forecast the price for each step, and other comments regarding FPL's nuclear fuel cost forecast.

a) Steps Required for Nuclear Fuel to be delivered to FPL's Plants

Four separate steps are required before nuclear fuel can be used in a commercial nuclear power reactor. These steps are summarized below.

(1) Mining: Uranium is produced in many countries such as Canada, Australia, Kazakhstan, and the United States. During the first step, uranium is mined from the ground using techniques such as open pit mining, underground mining, in-situ leaching operations, or production as a by-product from other mining operations, such as gold, copper, or phosphate rocks. The product from this first step is the raw uranium delivered as an oxide, U₃O₈ (sometimes referred to as yellowcake).

(2) Conversion: During the second step, the U₃O₈ is chemically converted into UF₆ which, when heated, changes into a gaseous state. This second step further removes any chemical impurities and serves as preparation for the third step, which requires uranium to be in a gaseous state.

(3) Enrichment: The third step is called enrichment. Natural uranium contains 0.711% of uranium at an atomic mass of 235 (U-235) and 99.289% of uranium at an atomic mass of 238 (U-238). FPL's nuclear reactors use uranium with a higher percentage of up to five percent (5%) of U-235 atoms. Because natural uranium does not contain a sufficient amount of U-235, the third step increases the percentage amount of U-235 from 0.711% to a level specified when designing the reactor core (typically in a range from approximately 3% to as high as 5%). The output of this enrichment process is enriched uranium in the form of UF₆.

(4) Fabrication: During the last step, fuel fabrication, the enriched UF6 is changed to a UO2 powder, pressed into pellets, and fed into tubes, which are sealed and bundled together into fuel assemblies. These fuel assemblies are then delivered to the plant site for insertion in a reactor.

Like other utilities, FPL has purchased raw uranium and the other components of the nuclear fuel cycle separately from numerous suppliers from different countries.

b) Price Forecasts for Each Step

(1) Mining: The impact of the earthquake and tsunami that struck the Fukushima nuclear complex in Japan in March 2011 is still having a significant impact on the uranium market. Current demand has declined and several of the production facilities have announced delays. Factors of importance are:

- Hedge funds are still very active in the market. This causes more speculative demand that is not tied to market fundamentals and causes the market price to move up or down just based on news that might affect future demand.
- Some of the uranium inventory from the U.S. Department of Energy (DOE) is finding its way into the market periodically to fund cleanup of certain Department of Energy facilities.
- Although a limited number of new nuclear units are scheduled to start production in the U.S. during the next 5 to 10 years, other countries, more specifically China, have announced an increase in construction of new units which may cause uranium prices to trend up in the near future.

Over a 10-year horizon, FPL expects the market to be more consistent with market fundamentals. The supply picture is more stable, with laws enacted to resolve the import of Russian-enriched uranium, by allowing some imports of Russian-enriched uranium to meet about 20-25% of needs for currently operating units, but with no restriction on the first core for new units and no restrictions after 2020. New and current facilities continue to add capacity to meet demands. Actual demand tends to grow over time because of the long lead time to build nuclear units. However, FPL cannot discount the possibility of future periodic sharp increase in prices, but believes such occurrences will likely be temporary in nature.

FPL's nuclear fuel price forecasts are the result of FPL's analysis based on inputs from various nuclear fuel market expert reports and studies.

(2) Conversion: The conversion market is also in a state of flux due to the Fukushima events. Insufficient planned production is currently forecasted after 2013 to meet the higher demand scenario, but it is projected to be sufficient to meet most reference case scenarios. As with additional raw uranium production, supply will expand beyond current level once more firm commitments are made including commitments to building new nuclear units. FPL expects long term price stability for conversion services to support world demand.

(3) Enrichment: As a result of the Fukushima events in March 2011, the near-term price of enrichment services has been declining for the last two years. However, plans for several of the new facilities that were expected to come on-line in the next few years have been delayed. Also, some of the current high operating cost diffusion plants have shut down. As with supply for the other steps of the nuclear fuel cycle, expansion of future capacity is feasible within the lead time for constructing new nuclear units and any other projected increase in demand. Meanwhile, world supply and demand will continue to be balanced such that FPL expects adequate supply of enrichment services. The tight supply/demand profile will most likely result in the price of enrichment services remaining stable or declining for the next few years before starting to increase.

(4) Fabrication: Because the nuclear fuel fabrication process is highly regulated by the Nuclear Regulatory Commission (NRC), not all production facilities can qualify as suppliers to nuclear reactors in the U.S. Although world supply and demand is expected to show significant excess capacity for the foreseeable future, the gap is not as wide for U.S. supply and demand. The supply for the U.S. market is expected to be sufficient to meet U.S. demand for the foreseeable future.

c) Other Comments Regarding FPL's Nuclear Fuel Cost Forecast

The calculations for the nuclear fuel cost forecasts used in FPL's 2012 and early 2013 resource planning work were performed consistent with the method then used for FPL's Fuel Clause filings, including the assumption of refueling outages every 18 months and plant operation at power uprate levels. The costs for each step to fabricate the nuclear fuels were added to come up with the total costs of

the fresh fuel to be loaded at each refueling (acquisition costs). The acquisition cost for each group of fresh fuel assemblies were then amortized over the energy produced by each group of fuel assemblies. FPL also added 1 mill per kilowatt hour net to reflect payment to DOE for spent fuel disposal.

**Schedule 5
Fuel Requirements
(for FPL only)**

Fuel Requirements	Units	Actual 1/		Forecasted									
		2011	2012	2013	2014	2015	2016	2017	2018	2019	2020	2021	2022
(1) Nuclear	Trillion BTU	241	188	291	298	300	306	303	300	306	302	300	357
(2) Coal	1,000 TON	3,135	2,692	2,879	3,048	3,451	3,121	3,509	3,417	3,695	3,822	3,896	3,888
(3) Residual (FO6) - Total	1,000 BBL	1,141	459	401	339	489	629	283	405	314	382	417	282
(4) Steam	1,000 BBL	1,141	459	401	339	489	629	283	405	314	382	417	282
(5) Distillate (FO2) - Total	1,000 BBL	332	23	5	39	56	214	63	23	5	15	22	5
(6) Steam	1,000 BBL	2	4	0	0	0	0	0	0	0	0	0	0
(7) CC	1,000 BBL	290	15	4	24	52	153	49	2	1	1	3	1
(8) CT	1,000 BBL	40	4	1	15	4	62	14	21	4	14	18	4
(9) Natural Gas - Total	1,000 MCF	555,988	595,396	527,468	551,511	554,210	572,447	585,028	599,799	587,485	596,930	601,354	571,252
(10) Steam	1,000 MCF	61,272	46,112	2,905	2,159	3,486	5,250	4,590	6,571	5,073	6,115	6,560	4,636
(11) CC	1,000 MCF	486,116	546,386	523,796	548,510	549,998	565,976	579,234	592,222	581,374	589,516	593,419	565,588
(12) CT	1,000 MCF	8,600	2,899	767	843	727	1,221	1,204	1,006	1,038	1,299	1,375	1,028

1/ Source: A Schedules.

Note: Solar contributions are provided on Schedules 6.1 and 6.2.

**Schedule 6.1
Energy Sources**

Energy Sources	Units	Actual ^{1/}		Forecasted									
		2011	2012	2013	2014	2015	2016	2017	2018	2019	2020	2021	2022
(1) Annual Energy Interchange ^{2/}	GWH	6,008	5,186	2,175	2,730	3,061	1,241	109	0	0	0	0	0
(2) Nuclear	GWH	21,510	16,916	27,184	27,812	27,986	28,609	28,295	27,967	28,568	28,193	27,977	33,482
(3) Coal	GWH	5,634	4,745	4,884	5,211	5,931	5,400	6,069	6,088	6,609	6,890	7,073	7,066
(4) Residual(FO6) -Total	GWH	630	378	246	198	309	368	162	228	174	213	230	157
(5) Steam	GWH	630	378	246	198	309	368	162	228	174	213	230	157
(6) Distillate(FO2) -Total	GWH	123	54	4	23	44	139	46	8	2	5	8	2
(7) Steam	GWH	1	2	0	0	0	0	0	0	0	0	0	0
(8) CC	GWH	107	49	3	19	43	123	42	2	0	1	2	0
(9) CT	GWH	15	4	1	4	1	16	4	6	1	4	6	1
(10) Natural Gas -Total	GWH	74,388	80,505	74,686	78,694	79,346	82,585	84,751	86,762	85,118	86,353	86,933	82,739
(11) Steam	GWH	5,429	5,543	231	176	272	439	376	552	423	514	555	383
(12) CC	GWH	68,328	74,668	74,387	78,455	79,017	82,044	84,274	86,121	84,602	85,721	86,254	82,264
(13) CT	GWH	631	295	67	63	57	103	101	90	93	117	123	92
(14) Solar ^{3/}	GWH	71	159	183	188	157	188	187	186	186	186	176	185
(15) PV	GWH	71	71	72	72	71	71	70	70	69	69	68	68
(16) Solar Thermal ^{4/}	GWH	0	89	111	117	86	117	117	117	117	117	107	117
(17) Other ^{5/}	GWH	4,090	2,922	3,675	3,862	4,512	4,924	4,968	4,717	6,543	6,990	7,146	7,334
Net Energy For Load ^{6/}	GWH	112,454	110,866	113,036	118,718	121,345	123,453	124,586	125,957	127,200	128,828	129,543	130,964

1/ Source: A Schedules and Actual Data for Next Generation Solar Centers Report

2/ The projected figures are based on estimated energy purchases from SJRPP, the Southern Companies (UPS contract), and other utilities.

3/ Represents output from FPL's PV and solar thermal facilities.

4/ For 2011, the Martin 8 Solar Thermal GWh output is rolled into row (12) for reporting purposes. In 2012, the GWh output is presented in row (16). The projected GWh contributions for 2013-2022 are also provided on row (16).

5/ Represents a forecast of energy expected to be purchased from Qualifying Facilities, Independent Power Producers, net of Economy and other Power Sales.

6/ Net Energy For Load values for the years 2013 - 2022 are also shown in Col. (19) on Schedule 2.3.

Schedule 6.2
Energy Sources % by Fuel Type

Energy Source	Units	Actual ^{1/}		Forecasted									
		2011	2012	2013	2014	2015	2016	2017	2018	2019	2020	2021	2022
(1) Annual Energy Interchange ^{2/}	%	5.3	4.7	1.9	2.3	2.5	1.0	0.1	0.0	0.0	0.0	0.0	0.0
(2) Nuclear	%	19.1	15.3	24.0	23.4	23.1	23.2	22.7	22.2	22.5	21.9	21.6	25.6
(3) Coal	%	5.0	4.3	4.3	4.4	4.9	4.4	4.9	4.8	5.2	5.3	5.5	5.4
(4) Residual (FO6) -Total	%	0.6	0.3	0.2	0.2	0.3	0.3	0.1	0.2	0.1	0.2	0.2	0.1
(5) Steam	%	0.6	0.3	0.2	0.2	0.3	0.3	0.1	0.2	0.1	0.2	0.2	0.1
(6) Distillate (FO2) -Total	%	0.1	0.0	0.0	0.0	0.0	0.1	0.0	0.0	0.0	0.0	0.0	0.0
(7) Steam	%	0.0	0.0	0.0	0.0	0.0	0.0	0.0	0.0	0.0	0.0	0.0	0.0
(8) CC	%	0.1	0.0	0.0	0.0	0.0	0.1	0.0	0.0	0.0	0.0	0.0	0.0
(9) CT	%	0.0	0.0	0.0	0.0	0.0	0.0	0.0	0.0	0.0	0.0	0.0	0.0
(10) Natural Gas -Total	%	66.1	72.6	66.1	66.3	65.4	66.9	68.0	68.9	66.9	67.0	67.1	63.2
(11) Steam	%	4.8	5.0	0.2	0.1	0.2	0.4	0.3	0.4	0.3	0.4	0.4	0.3
(12) CC	%	60.8	67.3	65.8	66.1	65.1	66.5	67.6	68.4	66.5	66.5	66.6	62.8
(13) CT	%	0.6	0.3	0.1	0.1	0.0	0.1	0.1	0.1	0.1	0.1	0.1	0.1
(14) Solar ^{3/}	%	0.1	0.1	0.2	0.2	0.1	0.2	0.1	0.1	0.1	0.1	0.1	0.1
(15) PV	%	0.1	0.1	0.1	0.1	0.1	0.1	0.1	0.1	0.1	0.1	0.1	0.1
(16) Solar Thermal ^{4/}	%	0.0	0.1	0.1	0.1	0.1	0.1	0.1	0.1	0.1	0.1	0.1	0.1
(17) Other ^{5/}	%	3.6	2.6	3.3	3.3	3.7	4.0	4.0	3.7	5.1	5.4	5.5	5.6
		100	100	100	100	100	100	100	100	100	100	100	100

1/ Source: A Schedules and Actual Data for Next Generation Solar Centers Report

2/ The projected figures are based on estimated energy purchases from SJRPP, the Southern Companies (UPS contract), and other utilities.

3/ Represents output from FPL's PV and solar thermal facilities.

4/ For 2011, the Martin 8 Solar Thermal GWh output is rolled into row (12) for reporting purposes. In 2012, the GWh output is presented in row (16). The projected GWh contributions for 2013-2022 are also provided on row (16).

5/ Represents a forecast of energy expected to be purchased from Qualifying Facilities, Independent Power Producers, net of Economy and other Power Sales.

**Schedule 7.1
Forecast of Capacity, Demand, and Scheduled
Maintenance At Time Of Summer Peak**

(1)	(2)	(3)	(4)	(5)	(6)	(7)	(8)	(9)	(10)	(11)	(12)	(13)	(14)
August of Year	Firm	Firm	Firm	Total		Total	Firm		Reserve		Scheduled Maintenance MW	Reserve	
	Installed Capacity MW	Capacity Import MW	Capacity Export MW	QF Firm MW	Capacity Available MW	Demand Peak MW	DSM MW	Demand Peak MW	Margin Before Maintenance MW	% of Peak		Margin After Maintenance MW	% of Peak
2013	24,215	1,309	0	635	26,159	21,790	2,006	19,785	6,374	32.2	826	5,548	28.0
2014	25,533	1,346	0	635	27,513	22,928	2,153	20,775	6,738	32.4	826	5,912	28.5
2015	25,604	1,456	0	595	27,654	23,359	2,279	21,080	6,574	31.2	0	6,574	31.2
2016	26,881	528	0	595	28,003	23,733	2,404	21,329	6,674	31.3	0	6,674	31.3
2017	26,441	491	0	595	27,527	24,122	2,529	21,593	5,933	27.5	0	5,933	27.5
2018	26,441	110	0	595	27,146	24,493	2,655	21,839	5,307	24.3	0	5,307	24.3
2019	26,441	110	0	595	27,146	24,901	2,780	22,121	5,024	22.7	0	5,024	22.7
2020	26,441	110	0	595	27,146	25,302	2,880	22,422	4,723	21.1	0	4,723	21.1
2021	26,441	110	0	775	27,326	25,560	2,980	22,580	4,746	21.0	0	4,746	21.0
2022	27,541	110	0	775	28,426	26,105	3,080	23,025	5,401	23.5	0	5,401	23.5

Col. (2) represents capacity additions and changes projected to be in-service by June 1st. These MW are generally considered to be available to meet Summer peak loads which are forecasted to occur during August of the year indicated.

Col. (6) = Col.(2) + Col.(3) - Col.(4) + Col.(5).

Col. (7) reflects the 2013 load forecast without incremental DSM or cumulative load management.

Col. (8) represents cumulative load management capability, plus incremental conservation, from 1/2013-on intended for use with the 2013 load forecast.

Col. (10) = Col. (6) - Col. (9)

Col. (11) = Col.(10) / Col.(9)

Col. (12) indicates the capacity of units projected to be out-of-service for planned maintenance during the Summer peak period.

This value is comprised of: an additional 826 MW of fossil-fueled capacity that will be out-of-service in the Summer of 2013 (at Martin Unit 1) and in the Summer of 2014 (at Martin Unit 2) due to the installation of electrostatic precipitators.

Col. (13) = Col. (10) - Col. (12)

Col. (14) = Col.(13) / Col.(9)

**Schedule 7.2
Forecast of Capacity , Demand, and Scheduled
Maintenance At Time of Winter Peak**

(1)	(2)	(3)	(4)	(5)	(6)	(7)	(8)	(9)	(10)	(11)	(12)	(13)	(14)
January of Year	Firm Installed Capacity MW	Firm Capacity Import MW	Firm Capacity Export MW	Firm QF MW	Total Firm Capacity Available MW	Total Peak Demand MW	DSM MW	Firm Winter Peak Demand MW	Reserve Margin Before Maintenance MW	% of Peak	Scheduled Maintenance MW	Reserve Margin After Maintenance MW	% of Peak
2013	24,135	1,316	0	635	26,086	20,270	1,480	18,790	7,295	38.8	1,539	5,756	30.6
2014	25,686	1,353	0	635	27,673	21,593	1,572	20,022	7,652	38.2	832	6,820	34.1
2015	27,102	1,463	0	595	29,159	22,154	1,641	20,513	8,646	42.2	0	8,646	42.2
2016	27,153	535	0	595	28,282	22,430	1,710	20,719	7,563	36.5	0	7,563	36.5
2017	28,138	498	0	595	29,231	22,662	1,780	20,882	8,348	40.0	0	8,348	40.0
2018	28,138	110	0	595	28,843	22,898	1,849	21,049	7,793	37.0	0	7,793	37.0
2019	28,138	110	0	595	28,843	23,125	1,918	21,207	7,636	36.0	0	7,636	36.0
2020	28,138	110	0	595	28,843	23,356	1,977	21,380	7,463	34.9	0	7,463	34.9
2021	28,138	110	0	775	29,023	23,601	2,030	21,571	7,452	34.5	0	7,452	34.5
2022	28,138	110	0	775	29,023	23,670	2,083	21,587	7,436	34.4	0	7,436	34.4

Col. (2) represents capacity additions and changes projected to be in-service by January 1st. These MW are generally considered to be available to meet winter peak loads which are forecasted to occur during January of the year indicated.

Col. (6) = Col.(2) + Col.(3) - Col.(4) + Col.(5).

Col. (7) reflects the 2013 load forecast without incremental DSM or cumulative load management. 2013 load is an actual load value.

Col. (8) represents cumulative load management capability, plus incremental conservation, from 1/2013-on intended for use with the 2013 load forecast.

Col. (10) = Col. (6) - Col. (9)

Col. (11) = Col.(10) / Col.(9)

Col. (12) indicates the capacity of units projected to be out-of-service for planned maintenance during the Winter peak period. This value is comprised of: (i) 717 MW (at Turkey Point Unit 4) that will be out-of-service in Winter of 2013 due to an extended planned outage as part of the capacity uprates project; (ii) an additional 822 MW that will be out-of-service in the Winter of 2013 (at Manatee Unit 1) due to the installation of electrostatic precipitators; and (iii) an additional 832 MW (at Martin Unit 1) that will be out-of-service during the Winter of 2014 due to the installation of electrostatic precipitators.

Col. (13) = Col. (10) - Col. (12)

Col. (14) = Col.(13) / Col.(9)

Schedule 7.3
Projection of Generation - Only Reserves
At Time Of Summer Peak (Assuming no additions in 2022)

(1)	(2)	(3)	(4)	(5)	(6)	(7)	(8)	(9)	(10)	(11)	(12)	(13)	(14)
August of Year	Firm Installed Capacity MW	Firm Capacity Import MW	Firm Capacity Export MW	QF MW	Total Firm Capacity MW	Total Peak MW	DSM MW	Firm Summer Demand MW	Reserve Margin Before Maintenance MW	% of Peak	Scheduled Maintenance MW	Reserve Margin After Maintenance MW	% of Peak
	2013	24,215	1,309	0	635	26,159	21,790	0	21,790	4,368	20.0	826	3,542
2014	25,533	1,346	0	635	27,513	22,928	0	22,928	4,585	20.0	826	3,759	16.4
2015	25,604	1,456	0	595	27,654	23,359	0	23,359	4,295	18.4	0	4,295	18.4
2016	26,881	528	0	595	28,003	23,733	0	23,733	4,270	18.0	0	4,270	18.0
2017	26,441	491	0	595	27,527	24,122	0	24,122	3,404	14.1	0	3,404	14.1
2018	26,441	110	0	595	27,146	24,493	0	24,493	2,652	10.8	0	2,652	10.8
2019	26,441	110	0	595	27,146	24,901	0	24,901	2,244	9.0	0	2,244	9.0
2020	26,441	110	0	595	27,146	25,302	0	25,302	1,843	7.3	0	1,843	7.3
2021	26,441	110	0	775	27,326	25,560	0	25,560	1,765	6.9	0	1,765	6.9
2022	26,441	110	0	775	27,326	26,105	0	26,105	1,221	4.7	0	1,221	4.7

Col. (2) represents capacity additions and changes, **assuming no generation addition in 2022 in order to demonstrate FPL's gen-only RM trend.**

Col. (6) = Col.(2) + Col.(3) - Col.(4) + Col.(5).

Col. (7) reflects the load forecast without incremental DSM or cumulative load management.

Col. (8) shows zero contribution from DSM in order to calculate FPL's reserves that are supplied only by generation resources.

Col. (10) = Col. (6) - Col. (9)

Col. (11) = Col.(10) / Col.(9)

Col. (12) indicates the capacity of units projected to be out-of-service for planned maintenance during the Summer peak period.

This value is comprised of 826 MW of fossil-fueled capacity that will be out-of-service in the Summer of 2013 (at Martin Unit 1) and in the Summer of 2014 (at Martin Unit 2) due to the installation of electrostatic precipitators.

Col. (13) = Col. (10) - Col. (12)

Col. (14) = Col.(13) / Col.(9)

Note that although there are no planned generating additions in this reserve margin calculation, the total firm capacity available in Col. (6) rises in 2021 due to the addition of 180MW of capacity from the EcoGen PPA.

Schedule 7.4
Projection of Generation - Only Reserves
At Time Of Summer Peak (Assuming TP6 is added in 2022)

(1)	(2)	(3)	(4)	(5)	(6)	(7)	(8)	(9)	(10)	(11)	(12)	(13)	(14)
August of Year	Firm Installed Capacity MW	Firm Capacity Import MW	Firm Capacity Export MW	QF Firm MW	Total Firm Capacity MW	Total Peak Demand MW	DSM MW	Firm Summer Peak Demand MW	Reserve Margin Before Maintenance MW % of Peak	Scheduled Maintenance MW	Reserve Margin After Maintenance MW % of Peak		
	2013	24,215	1,309	0	635	26,159	21,790	0	21,790	4,368	20.0	826	3,542
2014	25,533	1,346	0	635	27,513	22,928	0	22,928	4,585	20.0	826	3,759	16.4
2015	25,604	1,456	0	595	27,654	23,359	0	23,359	4,295	18.4	0	4,295	18.4
2016	26,881	528	0	595	28,003	23,733	0	23,733	4,270	18.0	0	4,270	18.0
2017	26,441	491	0	595	27,527	24,122	0	24,122	3,404	14.1	0	3,404	14.1
2018	26,441	110	0	595	27,146	24,493	0	24,493	2,652	10.8	0	2,652	10.8
2019	26,441	110	0	595	27,146	24,901	0	24,901	2,244	9.0	0	2,244	9.0
2020	26,441	110	0	595	27,146	25,302	0	25,302	1,843	7.3	0	1,843	7.3
2021	26,441	110	0	775	27,326	25,560	0	25,560	1,765	6.9	0	1,765	6.9
2022	27,541	110	0	775	28,426	26,105	0	26,105	2,321	8.9	0	2,321	8.9

Col. (2) represents capacity additions and changes, with Turkey Point Unit 6 added in 2022.

Col. (6) = Col.(2) + Col.(3) - Col.(4) + Col.(5).

Col. (7) reflects the load forecast without incremental DSM or cumulative load management.

Col. (8) shows zero contribution from DSM in order to calculate FPL's reserves that are supplied only by generation resources.

Col. (10) = Col. (6) - Col. (9)

Col. (11) = Col.(10) / Col.(9)

Col. (12) indicates the capacity of units projected to be out-of-service for planned maintenance during the Summer peak period. This value is comprised of 826 MW of fossil-fueled capacity that will be out-of-service in the Summer of 2013 (at Martin Unit 1) and in the Summer of 2014 (at Martin Unit 2) due to the installation of electrostatic precipitators.

Col. (13) = Col. (10) - Col. (12)

Col. (14) = Col.(13) / Col.(9)

**Schedule 8
Planned And Prospective Generating Facility Additions And Changes**

Plant Name	Unit No.	Location	Unit Type	Fuel				Const. Start Mo./Yr.	Comm. In-Service Mo./Yr.	Expected Retirement Mo./Yr.	Gen. Max. Nameplate KW	Firm Net Capability ⁽¹⁾		Status
				Fuel		Transport						Winter MW	Summer MW	
				Pri.	Alt.	Pri.	Alt.							
2013														
Port Everglades	3	City of Hollywood	ST	FO6	NG	WA	PL	—	—	—	402,050	(389)	(387)	OT
Port Everglades	4	City of Hollywood	ST	FO6	NG	WA	PL	—	—	—	402,050	(376)	(374)	OT
Turkey Point ²	2	Miami Dade County	ST	FO6	NG	WA	PL	—	—	Dec-13	402,050	(394)	(392)	OT
Sanford CT Upgrade	5C	Volusia County	CC	NG	No	PL	No	Jan-13	Feb-13	Unknown	1,188,860	—	9	OT
Turkey Point (Uprate) ⁽⁴⁾	4	Miami Dade County	ST	NP	No	TK	No	—	Mar-13	Unknown	759,900	—	115	V
Sanford CT Upgrade	4D	Volusia County	CC	NG	No	PL	No	Mar-13	Mar-13	Unknown	1,188,860	—	8	OT
Sanford CT Upgrade	4C	Volusia County	CC	NG	No	PL	No	Mar-13	Apr-13	Unknown	1,188,860	—	8	OT
Manatee ⁽³⁾	1	Manatee County	ST	FO6	NG	WA	PL	Sep-12	Jun-13	Unknown	863,300	(822)	(3)	OT
Cape Canaveral Next Generation Clean Energy Center	1	Brevard County	CC	NG	F02	TK	WA	Jun-11	Jun-13	Unknown	1,296,750	—	1,210	V
Martin ⁽³⁾	1	Martin County	ST	FO6	NG	PL	PL	Jun-13	Mar-14	Unknown	934,500	—	(826)	OT
2013 Changes/Additions Total:												(1,981)	(632)	
2014														
Sanford CT Upgrade	5B	Volusia County	CC	NG	No	PL	No	Aug-13	Sep-13	Unknown	1,188,860	10	—	OT
Turkey Point (Uprate)	4	Miami Dade County	ST	NP	No	TK	No	—	Mar-13	Unknown	759,900	115	—	V
Sanford CT Upgrade	5C	Volusia County	CC	NG	No	PL	No	Jan-13	Feb-13	Unknown	1,188,860	9	10	OT
Sanford CT Upgrade	4D	Volusia County	CC	NG	No	PL	No	Mar-13	Mar-13	Unknown	1,188,860	8	—	OT
Sanford CT Upgrade	4C	Volusia County	CC	NG	No	PL	No	Mar-13	Apr-13	Unknown	1,188,860	8	—	OT
Vero Beach Combined Cycle	1	Indian River	CC	NG	DFO	PL	TK	—	Jan-14	Unknown	—	46	44	OT
Manatee CT Upgrade	3C	Manatee County	CC	NG	No	PL	No	Apr-14	May-14	Unknown	1,224,510	—	10	OT
Manatee CT Upgrade	3D	Manatee County	CC	NG	No	PL	No	Apr-14	May-14	Unknown	1,224,510	—	9	OT
Turkey Point CT Upgrade	5A	Miami Dade County	CC	NG	F02	PL	TK	Jan-14	Feb-14	Unknown	1,224,510	—	8	OT
Turkey Point CT Upgrade	5B	Miami Dade County	CC	NG	F02	PL	TK	Jan-14	Feb-14	Unknown	1,224,510	—	8	OT
Turkey Point CT Upgrade	5C	Miami Dade County	CC	NG	F02	PL	TK	Feb-14	Mar-14	Unknown	1,224,510	—	8	OT
Turkey Point CT Upgrade	5D	Miami Dade County	CC	NG	F02	PL	TK	Feb-14	Mar-14	Unknown	1,224,510	—	9	OT
Manatee ⁽³⁾	1	Manatee County	ST	FO6	NG	WA	PL	Sep-12	Jun-13	Unknown	863,300	819	—	OT
Martin ⁽³⁾	1	Martin County	ST	FO6	NG	PL	PL	Jun-13	Mar-14	Unknown	934,500	(832)	826	OT
Martin ⁽³⁾	2	Martin County	ST	FO6	NG	PL	PL	Mar-14	Dec-14	Unknown	934,500	—	(826)	OT
Cape Canaveral Next Generation Clean Energy Center	1	Brevard County	CC	NG	F02	TK	WA	Jun-11	Jun-13	Unknown	1,296,750	1,355	—	V
Riviera Beach Next Generation Clean Energy Center	1	City of Riviera Beach	CC	NG	F02	TK	WA	Jun-12	Jun-14	Unknown	1,296,750	—	1,212	U
2014 Changes/Additions Total:												1,538	1,318	
2015														
Turkey Point CT Upgrade	5A	Miami Dade County	CC	NG	F02	PL	TK	Jan-14	Feb-14	Unknown	1,224,510	8	—	OT
Turkey Point CT Upgrade	5B	Miami Dade County	CC	NG	F02	PL	TK	Jan-14	Feb-14	Unknown	1,224,510	8	—	OT
Turkey Point CT Upgrade	5C	Miami Dade County	CC	NG	F02	PL	TK	Feb-14	Mar-14	Unknown	1,224,510	8	—	OT
Turkey Point CT Upgrade	5D	Miami Dade County	CC	NG	F02	PL	TK	Feb-14	Mar-14	Unknown	1,224,510	9	—	OT
Martin ⁽³⁾	1	Martin County	ST	FO6	NG	PL	PL	Jun-13	Mar-14	Unknown	934,500	832	—	OT
Manatee CT Upgrade	3C	Manatee County	CC	NG	No	PL	No	Apr-14	May-14	Unknown	1,224,510	10	—	OT
Manatee CT Upgrade	3D	Manatee County	CC	NG	No	PL	No	Apr-14	May-14	Unknown	1,224,510	9	—	OT
Riviera Beach Next Generation Clean Energy Center	1	City of Riviera Beach	CC	NG	F02	TK	WA	Jun-12	Jun-14	Unknown	1,296,750	1,344	—	U
Manatee CT Upgrade	3A	Manatee County	CC	NG	No	PL	No	Aug-14	Sep-14	Unknown	1,224,510	10	10	OT
Manatee CT Upgrade	3B	Manatee County	CC	NG	No	PL	No	Aug-14	Sep-14	Unknown	1,224,510	10	10	OT
Martin ⁽³⁾	2	Martin County	ST	FO6	NG	PL	PL	Mar-14	Dec-14	Unknown	934,500	—	826	OT
Fl. Myers CT Upgrade	2B	Lee County	CC	NG	No	PL	No	Feb-15	Mar-15	Unknown	1,775,390	—	8	OT
Fl. Myers CT Upgrade	2F	Lee County	CC	NG	No	PL	No	Feb-15	Mar-15	Unknown	1,775,390	—	9	OT
Fl. Myers CT Upgrade	2D	Lee County	CC	NG	No	PL	No	May-15	Jun-15	Unknown	1,775,390	—	8	OT
Fl. Myers CT Upgrade	2E	Lee County	CC	NG	No	PL	No	May-15	Jun-15	Unknown	1,775,390	—	9	OT
Fl. Myers CT Upgrade	2A	Lee County	CC	NG	No	PL	No	Jun-15	Jul-15	Unknown	1,775,390	—	8	OT
Fl. Myers CT Upgrade	2C	Lee County	CC	NG	No	PL	No	Jul-15	Aug-15	Unknown	1,775,390	—	9	OT
2015 Changes/Additions Total:												2,248	897	

- (1) The Winter Total MW value consists of all generation additions and changes achieved by January. The Summer Total MW value consists of all generation additions and changes achieved by June. All MW additions/changes occurring after August each year will be picked up for reserve margin calculation purposes in the following year.
- (2) This generating unit is currently serving as a synchronous condenser and is not included in reserve margin calculation. This unit can be brought back if needed in 2013 but for planning purposes it is not available for reserve margin calculations.
- (3) Outages for ESP work.
- (4) Turkey Point Nuclear Uprate will be performed during the extended outage.

Note: Schedule 8 shows only planned and prospective changes to generating facilities and does not reflect changes to existing purchases. Those changes are reflected on Tables ES-1, ES-2, I.B.1 and I.B.2.

**Schedule 8
Planned And Prospective Generating Facility Additions And Changes**

Plant Name	Unit No.	Location	Unit Type	Fuel				Const. Start Mo./Yr.	Comm. In-Service Mo./Yr.	Expected Retirement Mo./Yr.	Gen. Max. Nameplate KW	Firm Net Capability ⁽¹⁾		Status
				Pri.	Alt.	Transport						Winter MW	Summer MW	
						Pri.	Alt.							
ADDITIONS/ CHANGES														
2016														
Ft. Myers CT Upgrade	2B	Lee County	CC	NG	No	PL	No	Feb-15	Mar-15	Unknown	1,775,390	8	---	OT
Ft. Myers CT Upgrade	2F	Lee County	CC	NG	No	PL	No	Feb-15	Mar-15	Unknown	1,775,390	9	---	OT
Ft. Myers CT Upgrade	2D	Lee County	CC	NG	No	PL	No	May-15	Jun-15	Unknown	1,775,390	8	---	OT
Ft. Myers CT Upgrade	2E	Lee County	CC	NG	No	PL	No	May-15	Jun-15	Unknown	1,775,390	9	---	OT
Ft. Myers CT Upgrade	2A	Lee County	CC	NG	No	PL	No	Jun-15	Jul-15	Unknown	1,775,390	8	---	OT
Ft. Myers CT Upgrade	2C	Lee County	CC	NG	No	PL	No	Jul-15	Aug-15	Unknown	1,775,390	9	---	OT
Port Everglades Next Generation Clean Energy Center	1	City of Hollywood	CC	NG	FO2	TK	WA	Jun-14	Jun-16	Unknown	Unknown	---	1,277	U
2016 Changes/Additions Total:												51	1,277	
2017														
Vero Beach Combined Cycle	1	Indian River	CC	NG	DF0	PL	TK	---	---	Jan-17	---	(46)	(44)	OT
Port Everglades Next Generation Clean Energy Center	1	City of Hollywood	CC	NG	FO2	TK	WA	Jun-14	Jun-16	Unknown	Unknown	1,429	---	U
Turkey Point Synchronous Condenser	1	Miami Dade County	ST	FO6	NG	WA	PL	---	---	Jun-16	402,050	(398)	(396)	OT
2017 Changes/Additions Total:												1,031	(396)	
2018														
2018 Changes/Additions Total:												0	0	
2019														
2019 Changes/Additions Total:												0	0	
2020														
2020 Changes/Additions Total:												0	0	
2021														
2021 Changes/Additions Total:												0	0	
2022														
Turkey Point	6	Miami Dade County	ST	NP	No	TK	No	2014	Jun-22	Unknown	Unknown	---	1,100	T
2022 Changes/Additions Total:												0	1,100	

(1) The Winter Total MW value consists of all generation additions and changes achieved by January. The Summer Total MW value consists of all generation additions and changes achieved by June. All MW additions/changes occurring after August each year will be picked up for reserve margin calculation purposes in the following year.

Note: Schedule 8 shows only planned and prospective changes to generating facilities and does not reflect changes to existing purchases. Those changes are reflected on Tables ES-1, ES-2, I.B.1 and I.B.2.

Schedule 9
Status Report and Specifications of Proposed Generating Facilities

- (1) **Plant Name and Unit Number:** Turkey Point 4 Nuclear (Uprate)
- (2) **Capacity**
a. Summer 115 MW (Incremental)
b. Winter 115 MW (Incremental)
- (3) **Technology Type:** Nuclear
- (4) **Anticipated Construction Timing**
a. Field construction start-date: During scheduled refueling outage
b. Commercial In-service date: 2013
- (5) **Fuel**
a. Primary Fuel Uranium
b. Alternate Fuel ---
- (6) **Air Pollution and Control Strategy:** No change from existing unit
- (7) **Cooling Method:** No change from existing unit
- (8) **Total Site Area:** No change from existing unit
- (9) **Construction Status:** V (Under construction, more than 50% complete)
- (10) **Certification Status:** V (Under construction, more than 50% complete)
- (11) **Status with Federal Agencies:** V (Under construction, more than 50% complete)
- (12) **Projected Unit Performance Data:**
Planned Outage Factor (POF): No change from existing unit
Forced Outage Factor (FOF): No change from existing unit
Equivalent Availability Factor (EAF): No change from existing unit
Resulting Capacity Factor (%): No change from existing unit
Average Net Operating Heat Rate (ANOHR): No change from existing unit
Base Operation 75F, 100% No change from existing unit
- (13) **Projected Unit Financial Data *,****
Book Life (Years): 21 years (Matches the current operating license period.)
Total Installed Cost (\$/kW): ** TBD (See Note (1) for explanation.)
Direct Construction Cost (\$/kW): TBD (See Note (1) for explanation.)
AFUDC Amount (\$/kW): (See Note (2) for explanation.)
Escalation (\$/kW): (See Note (3) for explanation.)
Fixed O&M (\$/kW -Yr.): There is no additional O&M impact from this project.
Variable O&M (\$/MWH): There is no additional O&M impact from this project.
K Factor: (See Note (2) for explanation.)

NOTE:

- (1) The projected capital cost values for the capacity uprates at each of FPL's existing nuclear units is currently being reviewed in on-going analyses as this document is being prepared. The capital cost projections that will result from these analyses are expected to be presented in FPL's May 2013 Nuclear Cost Recovery filing.
- (2) Not applicable due to early recovery of capital carrying costs.
- (3) These costs are included in the Total Installed Cost value.

* \$/kW values are based on incremental Summer capacity.

** \$/incremental kW

Schedule 9
Status Report and Specifications of Proposed Generating Facilities

- (1) **Plant Name and Unit Number:** Cape Canaveral Next Generation Clean Energy Center
- (2) **Capacity**
a. Summer 1,210 MW
b. Winter 1,355 MW
- (3) **Technology Type:** Combined Cycle
- (4) **Anticipated Construction Timing**
a. Field construction start-date: 2011
b. Commercial In-service date: 2013
- (5) **Fuel**
a. Primary Fuel Natural Gas
b. Alternate Fuel Ultra-low sulfur distillate
- (6) **Air Pollution and Control Strategy:** Dry Low No_x Burners, SCR, Natural Gas, 0.0015% S. Distillate and Water Injection on Distillate
- (7) **Cooling Method:** Once-through cooling water
- (8) **Total Site Area:** 43 Acres
- (9) **Construction Status:** V (Under construction, more than 50% complete)
- (10) **Certification Status:** Permitted
- (11) **Status with Federal Agencies:** Permitted
- (12) **Projected Unit Performance Data:**
Planned Outage Factor (POF): 2.4%
Forced Outage Factor (FOF): 1.1%
Equivalent Availability Factor (EAF): 96.5%
Resulting Capacity Factor (%): Approx. 90 % (First Full Year Base Operation)
Average Net Operating Heat Rate (ANOHR): 6,484 Btu/kWh
Base Operation 75F,100%
- (13) **Projected Unit Financial Data *,****
Book Life (Years): 30 years
Total Installed Cost (2013 \$/kW): 921
Direct Construction Cost (\$/kW):
AFUDC Amount (\$/kW): 98
Escalation (\$/kW):
Fixed O&M (\$/kW-Yr): (2013 \$) 13.29
Variable O&M (\$/MWH): (2013 \$) 0.16
K Factor: 1.484

* \$/kW values are based on Summer capacity for in service year.

** Fixed O&M cost includes capital replacement.

NOTE: Total installed cost includes gas expansion, transmission interconnection and integration, escalation, and AFUDC. Demolition costs of existing plant are not included.

Schedule 9
Status Report and Specifications of Proposed Generating Facilities

- (1) **Plant Name and Unit Number:** Riviera Beach Next Generation Clean Energy Center
- (2) **Capacity ***
- | | |
|-----------|----------|
| a. Summer | 1,212 MW |
| b. Winter | 1,344 MW |
- (3) **Technology Type:** Combined Cycle
- (4) **Anticipated Construction Timing**
- | | |
|-----------------------------------|------|
| a. Field construction start-date: | 2012 |
| b. Commercial In-service date: | 2014 |
- (5) **Fuel**
- | | |
|-------------------|-----------------------------|
| a. Primary Fuel | Natural Gas |
| b. Alternate Fuel | Ultra-low sulfur distillate |
- (6) **Air Pollution and Control Strategy:** Dry Low No_x Burners, SCR, Natural Gas, 0.0015% S. Distillate and Water Injection on Distillate
- (7) **Cooling Method:** Once-through cooling water
- (8) **Total Site Area:** 33 Acres
- (9) **Construction Status:** U (Under construction, less than or equal to 50% complete)
- (10) **Certification Status:** Permitted
- (11) **Status with Federal Agencies:** Permitted
- (12) **Projected Unit Performance Data:**
- | | |
|--|--|
| Planned Outage Factor (POF): | 2.4% |
| Forced Outage Factor (FOF): | 1.1% |
| Equivalent Availability Factor (EAF): | 96.5% |
| Resulting Capacity Factor (%): | Approx. 90% (First Full Year Base Operation) |
| Average Net Operating Heat Rate (ANOHR): | 6,480 Btu/kWh |
| Base Operation 75F, 100% | |
- (13) **Projected Unit Financial Data *,****
- | | |
|------------------------------------|----------|
| Book Life (Years): | 30 years |
| Total Installed Cost (2014 \$/kW): | 1,053 |
| Direct Construction Cost (\$/kW): | |
| AFUDC Amount (\$/kW): | 121 |
| Escalation (\$/kW): | |
| Fixed O&M (\$/kW-Yr): (2014 \$) | 13.67 |
| Variable O&M (\$/MWH): (2014 \$) | 0.13 |
| K Factor: | 1.509 |

* \$/kW values are based on Summer capacity for in service year.

** Fixed O&M cost includes capital replacement.

NOTE: Total installed cost includes gas expansion, transmission interconnection and integration, escalation, and AFUDC. Demolition costs of existing plant are not included.

Schedule 9
Status Report and Specifications of Proposed Generating Facilities

- (1) **Plant Name and Unit Number:** Vero Beach Combined Cycle Capacity
- (2) **Capacity**
a. Summer 46 MW
b. Winter 44 MW
- (3) **Technology Type:** Combined Cycle
- (4) **Anticipated Construction Timing**
a. Field construction start-date: Not Applicable - See Note 1 below.
b. Commercial In-service date: 2014
- (5) **Fuel**
a. Primary Fuel Gas
b. Alternate Fuel Oil
- (6) **Air Pollution and Control Strategy:** N/A
- (7) **Cooling Method:** Once-through cooling water
- (8) **Total Site Area:** 16 Acres
- (9) **Construction Status:** See note 1 below
- (10) **Certification Status:** See note 1 below
- (11) **Status with Federal Agencies:** See note 1 below
- (12) **Projected Unit Performance Data:**
- | | | |
|--|-------|---------|
| Planned Outage Factor (POF): | 20.5% | |
| Forced Outage Factor (FOF): | 0.0% | |
| Equivalent Availability Factor (EAF): | 72.5% | |
| Resulting Capacity Factor (%): | 3.88% | |
| Average Net Operating Heat Rate (ANOHR): | 9,397 | Btu/kWh |
| Base Operation 75F, 100% | | |
- (13) **Projected Unit Financial Data**
- | | | |
|-----------------------------------|----------------|-------|
| Book Life (Years): | TBD | years |
| Total Installed Cost (\$/kW): | Not Applicable | |
| Direct Construction Cost (\$/kW): | Not Applicable | |
| AFUDC Amount (\$/kW): | Not Applicable | |
| Escalation (\$/kW): | Not Applicable | |
| Fixed O&M (\$/kW-Yr): (\$) | Not Applicable | |
| Variable O&M (\$/MWH): (\$) | Not Applicable | |
| K Factor: | Not Applicable | |

NOTE 1: The combined cycle capacity consists of two units. FPL is also taking ownership of three other steam units. The three units will be retired as soon as they are acquired.

Schedule 9
Status Report and Specifications of Proposed Generating Facilities

- (1) **Plant Name and Unit Number:** Port Everglades Next Generation Clean Energy Center
- (2) **Capacity**
a. Summer 1,277 MW
b. Winter 1,429 MW
- (3) **Technology Type:** Combined Cycle
- (4) **Anticipated Construction Timing**
a. Field construction start-date: 2014
b. Commercial In-service date: 2016
- (5) **Fuel**
a. Primary Fuel Natural Gas
b. Alternate Fuel Ultra-low sulfur distillate
- (6) **Air Pollution and Control Strategy:** Dry Low No_x Burners, SCR, Natural Gas, 0.0015% S. Distillate and Water Injection on Distillate
- (7) **Cooling Method:** Once-through cooling water
- (8) **Total Site Area:** Existing Site Acres
- (9) **Construction Status:** U (Under construction, less than or equal to 50% complete)
- (10) **Certification Status:** ---
- (11) **Status with Federal Agencies:** ---
- (12) **Projected Unit Performance Data:**
Planned Outage Factor (POF): 3.5%
Forced Outage Factor (FOF): 1.1%
Equivalent Availability Factor (EAF): 95.4%
Resulting Capacity Factor (%): Approx. 90% (First Full Year Base Operation)
Average Net Operating Heat Rate (ANOHR): 6,330 Btu/kWh
Base Operation 75F, 100%
- (13) **Projected Unit Financial Data *,****
Book Life (Years): 30 years
Total Installed Cost (2016 \$/kW): 928
Direct Construction Cost (\$/kW):
AFUDC Amount (\$/kW): 87
Escalation (\$/kW):
Fixed O&M (\$/kW-Yr): (2016 \$) 30.00
Variable O&M (\$/MWH): (2016 \$) 0.10
K Factor: 1.51

* \$/kW values are based on Summer capacity.

** Fixed O&M cost includes capital replacement.

NOTE: Total installed cost includes gas expansion, transmission interconnection and integration, escalation, and AFUDC. Demolition costs of existing plant are not included.

Schedule 9
Status Report and Specifications of Proposed Generating Facilities

- (1) **Plant Name and Unit Number:** Turkey Point Nuclear Unit 6
- (2) **Capacity**
a. Summer 1,100 MW
b. Winter 1,100 MW
- (3) **Technology Type:** Nuclear
- (4) **Anticipated Construction Timing**
a. Field construction start-date: 2015
b. Commercial In-service date: 2022
- (5) **Fuel**
a. Primary Fuel Uranium Dioxide
b. Alternate Fuel N/A
- (6) **Air Pollution and Control Strategy:** N/A
- (7) **Cooling Method:** Mechanical Draft Cooling Towers
- (8) **Total Site Area:** 211 Acres
- (9) **Construction Status:** T (Regulatory approval received, but not under construction)
- (10) **Certification Status:** T (Regulatory approval received, but not under construction)
- (11) **Status with Federal Agencies:** T (Regulatory approval received, but not under construction)
- (12) **Projected Unit Performance Data:**
Planned Outage Factor (POF): TBD
Forced Outage Factor (FOF): TBD
Equivalent Availability Factor (EAF): TBD
Resulting Capacity Factor (%): Approx. 90% (First Full Year Base Operation)
Average Net Operating Heat Rate (ANOHR): TBD Btu/kWh
Base Operation 75F, 100%
- (13) **Projected Unit Financial Data *,****
Book Life (Years): TBD years
Total Installed Cost (\$/kW): TBD
Direct Construction Cost (\$/kW): TBD
AFUDC Amount (\$/kW): TBD
Escalation (\$/kW): TBD
Fixed O&M (\$/kW-Yr): (\$) TBD
Variable O&M (\$/MWH): (\$) TBD
K Factor: TBD

* \$/kW values are based on Summer capacity.

** Fixed O&M cost includes capital replacement.

NOTE: Total installed cost includes gas expansion, transmission interconnection and integration, escalation, and AFUDC. Demolition costs of existing plant are not included.

Schedule 10
Status Report and Specifications of Proposed Transmission Lines

Turkey Point 4 Nuclear (Uprate)

The Turkey Point 4 Nuclear (Uprate) does not require any “new” transmission lines.

Schedule 10
Status Report and Specifications of Proposed Transmission Lines

Cape Canaveral Next Generation Clean Energy Center (Modernization)

The Cape Canaveral Next Generation Clean Energy Center which will result from the modernization of the Cape Canaveral power plant site does not require any "new" transmission lines.

Schedule 10
Status Report and Specifications of Proposed Transmission Lines

Riviera Beach Next Generation Clean Energy Center (Modernization)

The Riviera Beach Energy Center which will result from the modernization of the Riviera Beach power plant site will require one new line and existing lines to be extended and reconfigured to accommodate the increased capacity.

(1)	Point of Origin and Termination:	Riviera Beach – Cedar Substation
(2)	Number of Lines:	1
(3)	Right-of-way	Existing, FPL - Owned
(4)	Line Length:	15 miles
(5)	Voltage:	230 kV
(6)	Anticipated Construction Timing:	Start date: 2012 End date: 2014
(7)	Anticipated Capital Investment: (Trans.and Sub.)	\$12,100,000
(8)	Substations:	Riviera Beach Substation and Cedar Substation
(9)	Participation with Other Utilities:	None

Schedule 10
Status Report and Specifications of Proposed Transmission Lines

Vero Beach Existing Combined Cycle Capacity

The Vero Beach existing combined cycle capacity that FPL will take ownership of starting January 1, 2014 does not require any "new" transmission lines.

Schedule 10
Status Report and Specifications of Proposed Transmission Lines

Port Everglades Next Generation Clean Energy Center

The Port Everglades Next Generation Clean Energy Center which will result from the modernization of the Port Everglades power plant site does not require any “new” transmission lines.

Schedule 10
Status Report and Specifications of Proposed Transmission Lines

Turkey Point Nuclear Unit 6

The Turkey Point New Nuclear Project starting with the addition of Turkey Point Unit 6 will require a new substation and five new transmission lines terminating at existing substations.

- | | | |
|-----|---|---|
| (1) | Point of Origin and Termination: | New Clear Sky Substation – Levee Substation |
| (2) | Number of Lines: | 2 |
| (3) | Right-of-way | FPL Owned |
| (4) | Line Length: | 43 miles |
| (5) | Voltage: | 500 kV |
| (6) | Anticipated Construction Timing: | Start date: TBD
End date: TBD |
| (7) | Anticipated Capital Investment:
(Trans.and Sub.) | \$ TBD |
| (8) | Substations: | New Clear Sky Substation and Levee Substation |
| (9) | Participation with Other Utilities: | None |

- | | | |
|-----|---|--|
| (1) | Point of Origin and Termination: | New Clear Sky Substation – Pennsuco Substation |
| (2) | Number of Lines: | 1 |
| (3) | Right-of-way | FPL Owned |
| (4) | Line Length: | 52 miles |
| (5) | Voltage: | 230 kV |
| (6) | Anticipated Construction Timing: | Start date: TBD
End date: TBD |
| (7) | Anticipated Capital Investment:
(Trans.and Sub.) | \$ TBD |
| (8) | Substations: | New Clear Sky Substation and Pennsuco Substation |
| (9) | Participation with Other Utilities: | None |

Schedule 10
Status Report and Specifications of Proposed Transmission Lines

Turkey Point Nuclear Unit 6 (continued)

(1)	Point of Origin and Termination:	New Clear Sky Substation – Davis Substation
(2)	Number of Lines:	1
(3)	Right-of-way	FPL Owned
(4)	Line Length:	19 miles
(5)	Voltage:	230 kV
(6)	Anticipated Construction Timing:	Start date: TBD End date: TBD
(7)	Anticipated Capital Investment: (Trans.and Sub.)	\$ TBD
(8)	Substations:	New Clear Sky Substation and Davis Substation
(9)	Participation with Other Utilities:	None

(1)	Point of Origin and Termination:	Davis Substation – Miami Substation
(2)	Number of Lines:	1
(3)	Right-of-way	FPL Owned
(4)	Line Length:	18 miles
(5)	Voltage:	230 kV
(6)	Anticipated Construction Timing:	Start date: TBD End date: TBD
(7)	Anticipated Capital Investment: (Trans.and Sub.)	\$ TBD
(8)	Substations:	Davis Substation and Miami Substation
(9)	Participation with Other Utilities:	None

Schedule 10
Status Report and Specifications of Proposed Transmission Lines

Turkey Point Nuclear Unit 6 (continued)

(1)	Point of Origin and Termination:	New Clear Sky Substation – Turkey Point Substation
(2)	Number of Lines:	1
(3)	Right-of-way	FPL Owned
(4)	Line Length:	0.5 miles
(5)	Voltage:	230 kV
(6)	Anticipated Construction Timing:	Start date: TBD End date: TBD
(7)	Anticipated Capital Investment: (Trans.and Sub.)	\$ TBD
(8)	Substations:	New Clear Sky Substation and Turkey Point Substation
(9)	Participation with Other Utilities:	None

Schedule 11.1

**Existing FIRM and NON-FIRM Capacity and Energy by Primary Fuel Type
Actuals for the Year 2012**

	(1) Generation by Primary Fuel	(3) Net (MW) Capability				(6) NEL GWh ⁽²⁾	(7) Fuel Mix %
		(2) Summer (MW)	Summer (%)	(4) Winter (MW)	(5) Winter (%)		
(1)	Coal	896	3.4%	911	3.3%	4,745	4.3%
(2)	Nuclear	3,333	12.8%	3,422	12.5%	16,916	15.3%
(3)	Residual	4,822	18.5%	4,862	17.8%	378	0.3%
(4)	Distillate	648	2.5%	710	2.6%	54	0.0%
(5)	Natural Gas	14,331	55.1%	15,397	56.3%	80,594	72.7%
(6)	Solar	35	0.1%	35	0.1%	71	0.1%
(7)	FPL Existing Units Total⁽¹⁾ :	24,065	92.5%	25,337	92.7%	102,758	92.7%
(8)	Renewables (Purchases)- Firm	61.0	0.2%	112.0	0.4%	496	0.4%
(9)	Renewables (Purchases)- Non-Firm	Not Applicable	---	Not Applicable	---	867	0.8%
(10)	Renewable Total:	61.0	0.2%	112.0	0.4%	1,363	1.23%
(11)	Purchases Other :	1,889.0	7.3%	1,896.0	6.9%	6,746	6.1%
(12)	Total:	26,015.0	100.0%	27,345.0	100.0%	110,867	100.0%

Note:

- (1) FPL Existing Units Total values on row (7), columns (2) and (4), match the System Firm Generating Capacity values found on Schedule 1 for Summer and Winter.
- (2) Net Energy for Load GWh values on row (12), column (6), matches Schedule 6.1 value for 2012.

Schedule 11.2

**Existing NON-FIRM Self-Service Renewable Generation Facilities
Actuals for the Year 2012**

1	2	3	4	5	6 = 3 + 4 - 5
Type of Facility	Installed Capacity DC (MW)	Renewable Projected Annual Output (MWh)	Annual Energy Purchased from FPL (MWh)	Annual Energy Sold to FPL (MWh)	Projected Annual Energy Used by Customers (MWh)
Customer-Owned Renewable Generation (0 kW to 10 kW)	9.9	11,601	103,518	408	114,710
Customer-Owned Renewable Generation (> 10 kW to 100 kW)	5.5	6,454	170,710	298	176,866
Customer-Owned Renewable Generation (> 100 kW - 2 MW)	3.6	4,647	111,472	180	115,938
Total	19	22,702	385,699	886	407,514

Notes:

- (1) There were 2,117 customers with renewable generation facilities interconnected with FPL on December 31, 2012.
- (2) The Installed Capacity value is the sum of the nameplate ratings (DC MW) for all of the customer-owned renewable generation facilities connected as of Dec. 31, 2012.
- (3) The Projected Annual Output value is based on NREL's PV Watts 1 program and the Installed Capacity value in column (2), adjusted for the date when each facility was installed and assuming each facility operated as planned.
- (4) The Annual Energy Purchased from FPL is an actual value from FPL's metered data for 2012.
- (5) The Annual Energy Sold to FPL is an actual value from FPL's metered data for 2012.
- (6) The Projected Annual Energy Used by Customers is a projected value that equals:
(Renewable Projected Annual output + Annual Energy Purchased from FPL) minus the Annual Energy Sold to FPL.

(This page is left intentionally blank.)

CHAPTER IV

Environmental and Land Use Information

(This page is left intentionally blank.)

IV. Environmental and Land Use Information

IV.A Protection of the Environment

Florida is a sensitive, temperate/sub-tropical environment containing a number of distinct ecosystems with many endangered or threatened plant and animal species. Florida's communities and ecology require the same air, land, and water resources that are necessary to meet the demand for the generation, transmission, and distribution of electricity. The general public has an expectation that large corporations such as FPL will conduct their business in an environmentally responsible manner that minimizes demands on the natural environment.

FPL has been recognized for many years as one of the leaders among electric utilities for its commitment to the environment. Being responsible stewards of the environment is ingrained in FPL's corporate culture. FPL has one of the lowest emissions profiles among U.S. utilities and in 2012 its carbon dioxide (CO₂) emission rate was 29% lower (better) than the industry average.

The environmental leadership of FPL and its parent company, NextEra Energy, Inc., has been heralded by many outside organizations as demonstrated by a few recent examples. NextEra Energy, Inc. was named to the 2012 Dow Jones Sustainability Index (DJSI) of the leading companies in North America for corporate sustainability for the fourth consecutive year. The DJSI North America selects the top 20 percent of companies in sustainability performance from the 600 largest companies in North America. According to Sustainable Asset Management, the investment research firm that conducts the DJSI research, the evaluation is continuously adapted to capture the sustainability trends that are at the forefront of each industry sector and are likely to have an impact on the companies' competitive landscape.

According to the 2013 "World's Most Admired Companies" report released by Fortune magazine, NextEra Energy, Inc. ranked, for a record seventh consecutive year, No. 1 in its industry. Being ranked first, for six consecutive years, is unprecedented in the industry and according to *Fortune*, America's Most Admired Companies is "the definitive report card on corporate reputations". In the same report, NextEra Energy, Inc. ranked in the top 10 among the most admired companies in the state of Florida.

FPL's responsible tree care practices across its 35-county service area have been recognized for almost a decade. FPL has been the recipient of the Tree Line USA award annually from 2003 - 2012. This award is sponsored by the Arbor Day Foundation in cooperation with the National Association of State Foresters. The recognition is given to utilities that demonstrate quality tree care practices, annual worker training, and public education programs.

In 2012, FPL continued to support the Loggerhead Marineline Center with a \$25,000 donation toward the acquisition of a larger tank to assist in sea turtle rehabilitation. In past years FPL has won the Loggerhead Marineline Center's "Blue Business of the Year" award. This award is given to those who are leading the way in raising awareness about, and have made significant contributions to improve and protect, South Florida's oceans, beaches, and wildlife. The award recognized FPL's protection and conservation of the endangered Florida manatee and its fostering of public and employee education and support.

FPL employees serve as board members for many organizations that focus on environmental restoration, preservation, and stewardship. A partial list of these organizations includes: Audubon Florida, the Everglades Foundation, the Arthur R. Marshall Foundation, and the Palm Beach Zoo.

IV.B FPL's Environmental Statement

To reaffirm its commitment to conduct business in an environmentally responsible manner, FPL developed an Environmental Statement in 1992 to clearly define its position, and FPL continues to hold that position. This statement reflects how FPL incorporates environmental values into all aspects of its activities and serves as a framework for new environmental initiatives throughout the company.

FPL's Environmental Statement

It is the Company's intent to continue to conduct its business in an environmentally responsible manner. Accordingly, Florida Power & Light Company will:

- Comply with the spirit and intent, as well as the letter of, environmental laws, regulations, and standards;
- Incorporate environmental protection and stewardship as an integral part of the design, construction, operation, and maintenance of our facilities;

- Encourage the wise use of energy to minimize the impact on the environment;
- Communicate effectively on environmental issues; and
- Conduct periodic self-evaluations and report performance.

IV.C Environmental Management

In order to implement the Environmental Statement, FPL has an Environmental Management System to direct and control the fulfillment of the organization's environmental responsibilities. A key component of the system is an Environmental Assurance Program. Other components of the system include: executive management support and commitment, a dedicated environmental corporate governance program, written environmental policies and procedures, delineation of organizational responsibilities and individual accountabilities, allocation of appropriate resources for environmental compliance management (which includes reporting and corrective action when non-compliance occurs), environmental incident and/or emergency response, environmental risk assessment/management, environmental regulatory development and tracking, and environmental management information systems.

As part of its commitment to excellence and continuous improvement, FPL will begin to implement an enhanced environmental data management information system (EDMIS) in 2013. Environmental data management software systems are increasingly viewed as an industry best-management practice for environmental compliance needs. FPL's top goal is to improve the flow of environmental data between site operations and corporate services to ensure compliance and improve operating efficiencies. In addition, the EDMIS will help in standardizing data collection, reducing the time to generate state and federal agency reports, and improving external reporting to the public.

IV.D Environmental Assurance Program

FPL's Environmental Assurance Program consists of activities that are designed to evaluate environmental performance, verify compliance with corporate policy as well as legal and regulatory requirements, and communicate results to corporate management. The principal mechanism for pursuing environmental assurance is the environmental audit. An environmental audit may be defined as a management tool comprising a systematic, documented, periodic, and objective evaluation of the performance of the organization and of the specific management systems and equipment designed to protect

the environment. The environmental audit's primary objectives are to facilitate management control of environmental practices and assess compliance with existing environmental regulatory requirements and FPL policies.

IV.E Environmental Communication and Facilitation

FPL is involved in many efforts to enhance environmental protection through the facilitation of environmental awareness and in public education. Some of FPL's 2012 environmental outreach activities are summarized below in Table IV.E.1.

Table IV.E.1: 2012 FPL Environmental Outreach Activities

Activity	# of Participants (Approx.)
Visitors to FPL's Energy Encounter at St. Lucie	15,000
Visitors to Manatee Park, Ft. Myers	198,000
Number of website visits to FPL's Environmental & Corporate Responsibility Websites	>200,000
Number of pieces of Environmental literature distributed	>20,000
Visitors to Barley Barber Swamp	>3000
Martin Energy Center Solar Tours	500
Solar Schools Program (# of schools participating)	1 school and 2 non-profits

IV.F Preferred and Potential Sites

Based upon its projection of future resource needs, FPL has identified seven (7) Preferred Sites and five (5) Potential Sites for future generation additions. Preferred Sites are those locations where FPL has conducted significant reviews and has either taken action, is currently committed to take action, or is likely to take action, to site new generating capacity. Potential Sites are those sites that have attributes that support the siting of generation and are under consideration as a location for future generation. Some of these sites are currently in use as existing generation sites and some are not. The identification of a Potential Site does not indicate that FPL has made a definitive decision to pursue generation (or generation expansion in the case of an existing generation site) at that location, nor does this designation indicate that the size or technology of a generator has been determined. The Preferred Sites and Potential Sites are discussed in separate sections below.

As has been described in previous FPL Site Plans, FPL also considers a number of other sites as possible sites for adding future power generation. These include the remainder of FPL's existing generation sites and other Greenfield sites. FPL is also analyzing the potential for modernizing additional existing power plant sites such as is now being done at the Cape Canaveral, Riviera Beach, and Port Everglades sites. Analyses of any modernization candidates would include evaluation of numerous factors including: fuel delivery, transmission, permitting, etc.

IV.F.1 Preferred Sites

FPL currently identifies seven (7) Preferred Sites. Four of these are existing sites: Turkey Point, Cape Canaveral, Riviera Beach, and Port Everglades; two are new plant sites: Hendry County and Northeast Okeechobee County; and one is the site of a former FPL generating unit: Palatka. The Turkey Point site is discussed in regard to two generation projects. The first Turkey Point project discussed is the Extended Power Uprate (EPU) project to increase capacity at the existing Turkey Point Unit 4. This project is expected to be completed at about the time this document is filed. The second Turkey Point project discussed is the first of two new nuclear units. Turkey Point Unit 6 is currently projected in the resource plan discussed in this Site Plan to come in-service in 2022. The 2022 date represents the current projection of the earliest practical in-service date for this unit.

The Cape Canaveral, Riviera Beach, and Port Everglades sites are locations where the modernization work to replace older steam generating units with new combined cycle (CC) technology is in progress. The modernization work at these three sites is scheduled to be completed in 2013, 2014, and 2016, respectively. The Hendry County, Okeechobee County, and Palatka sites are the likely next locations for new CC units after the modernization projects have been completed. In addition, the Hendry County and Okeechobee County sites are also likely sites for new photovoltaic (PV) facilities.

The first four Preferred Sites are discussed below in general chronological order with respect to when the capacity additions are projected to occur. The remaining three Preferred Sites are discussed in alphabetical order.

Preferred Site # 1: Turkey Point Plant, Miami-Dade County

The Turkey Point Plant (Turkey Point) is located on the west side of Biscayne Bay, 25 miles south of Miami. Turkey Point is directly on the shoreline of Biscayne Bay and is

geographically located approximately 9 miles east of Florida City on Palm Drive. The land surrounding Turkey Point is owned by FPL and acts as a buffer zone. Turkey Point is comprised of two natural gas/oil conventional steam units (Units 1 & 2), two nuclear units (Units 3 & 4), one combined cycle natural gas unit (Unit 5), nine small diesel generators, and the cooling canals. The Everglades Mitigation Bank (EMB), an approximately 13,000 acre, FPL-maintained natural wildlife and wetlands area that has been set aside, is located to the south and west of the site.

As mentioned above, the Turkey Point Plant site is discussed in this document in regard to two generation projects: the EPU project for an existing nuclear unit (Turkey Point Unit 4), and a new nuclear unit (Turkey Point Unit 6).

Turkey Point Unit 4 has been in operation since 1973. An EPU project for Unit 4 is being completed at the time this document is being finalized. Similar EPU projects were completed during 2012 for three other existing FPL nuclear units: St. Lucie Unit 1, St. Lucie Unit 2, and Turkey Point Unit 3. The EPU work involves changes to several existing main components within the existing facilities to increase their capability to produce steam for the generation of electricity. This capacity uprate, along with similar capacity uprates of FPL's three other existing nuclear units, was included in a final order approved by the Secretary of the Florida Department of Environmental Protection in October 2008.

In regard to Turkey Point Unit 6, FPL is pursuing licensing for two new nuclear units at Turkey Point. Each of these two units would provide 1,100 MW of capacity. The current projections for the earliest practical in-service dates for the two new units are 2022 (for Turkey Point Unit 6) and 2023 (for Turkey Point Unit 7). Because the in-service date for Turkey Point Unit 7 is beyond the 2013 - 2022 reporting time frame of this document, only Turkey Point Unit 6 is discussed in this report. In addition to the two generating units, supporting buildings, facilities and equipment, will be located on the Turkey Point Units 6 & 7 site, along with a construction laydown area. Proposed associated facilities include: a nuclear administration building, a training building, a parking area; an FPL reclaimed water treatment facility and reclaimed water pipelines; radial collector wells and delivery pipelines; an equipment barge unloading area; transmission lines (and transmission system improvements elsewhere within Miami-Dade County), access roads and bridges, and potable water pipelines.

a. **U.S. Geological Survey (USGS) Map**

USGS maps of the Turkey Point area, with the location of Turkey Point Units 3, 4, 6 and 7 identified, are found at the end of this chapter.

b. **Proposed Facilities Layout**

Maps of the general layout of Turkey Point Unit 4 (which also includes Turkey Point Unit 3), and of Turkey Point Unit 6 (which also includes Turkey Point Unit 7), are found at the end of this chapter.

c. **Map of Site and Adjacent Areas**

Land Use / Land Cover overview maps of the Turkey Point Units 3 & 4 and Turkey Point Units 6 & 7 sites and adjacent areas are also found at the end of this chapter.

d. **Existing Land Uses of Site and Adjacent Areas**

Turkey Point Plant is currently home to five generating units and support facilities that occupy approximately 150 acres of the approximately 9,400-acre Turkey Point property. Prominent features beyond the power block area include the intake system, cooling canal system, switchyard, spent fuel storage facilities, and technical and administrative support facilities. The cooling canal system occupies approximately 5,900 acres.

The two 400-megawatt (MW) (nominal) fossil fuel-fired steam electric generation units at Turkey Point have been in service since 1967 (Unit 1) and 1968 (Unit 2). These units have historically burned residual fuel oil and/or natural gas with a maximum equivalent sulfur content of one percent. Unit 2 is currently serving, not as a power generating unit, but as a synchronous condenser to provide voltage support to the southeastern end of FPL's transmission system. The two original 700-MW (nominal) nuclear units have been in service since 1972 (Unit 3) and 1973 (Unit 4). Turkey Point Units 3 and 4 are pressurized water reactor (PWR) units. Turkey Point Unit 5 is a nominal 1,150-MW natural gas-fired combined cycle unit that began operation in 2007. The site for the new Unit 6 (and Unit 7) is south of existing Units 3 and 4 and occupies approximately 300 acres within the existing cooling canal system.

Properties adjacent to Turkey Point property are almost exclusively undeveloped land. The FPL-owned EMB is adjacent to most of the western and southern boundaries of Turkey Point property. The South Florida Water Management District

(SFWMD) Canal L-31E is also situated to the west of Turkey Point property. The eastern portions of Turkey Point property are adjacent to Biscayne Bay, the Biscayne National Park (BNP), and Biscayne Bay Aquatic Preserve. The southeastern portion of Turkey Point property is bounded by state-owned land located on Card Sound. The Homestead Bayfront Park, owned and operated by Miami-Dade County, is situated to the north of the Turkey Point property.

e. **General Environment Features On and In the Site Vicinity**

1. **Natural Environment**

Turkey Point is located directly on the northwest, west, and southwest shoreline of Biscayne Bay and the Biscayne National Park, 25 miles south of Miami. Biscayne National Park was first established in 1968 as a National Monument and was expanded in 1980 to approximately 173,000 acres of water, coastal lands, and 42 keys. A portion of Biscayne Bay Aquatic Preserve, a state-owned preserve, is adjacent to the eastern boundary of the Turkey Point plant property. The Biscayne Bay Aquatic Preserve is a shallow, subtropical lagoon consisting of approximately 69,000 acres of submerged State land that has been designated as an Outstanding Florida Water.

The Turkey Point Unit 4 EPU project is located within the area of the existing Turkey Point Unit 4 site, which currently includes a nuclear generation unit and supporting facilities. The approximately 300-acre Turkey Point Units 6 & 7 site consists of the plant area and adjacent areas designated for laydown and ancillary facilities. The site includes hypersaline mud flats, man-made active cooling canals, man-made remnant canals, previously filled areas/roadways, mangrove heads associated with historical tidal channels, dwarf mangroves, open water /discharge canal associated with the cooling canals on the western portion of the site, wet spoil berms associated with remnant canals, and upland spoil areas.

2. **Listed Species**

Threatened, endangered, and/or animal species of special concern known to occur at the site, and in the nearby Biscayne National Park, include the peregrine falcon (*Falco peregrinus*), wood stork (*Mycteria americana*), American crocodile (*Crocodylus acutus*), mangrove rivulus (*Rivulus marmoratus*), roseate spoonbill (*Ajaja ajaja*), little blue heron (*Egretta caerulea*), snowy egret (*Egretta thula*),

American oystercatcher (*Haematopus palliatus*), least tern (*Sterna antillarum*), the white ibis (*Eudocimus albus*), and bald eagle (*Haliaeetus leucocephalus*). No bald eagle nests are known to exist in the vicinity of the site. The federally listed, threatened American crocodile thrives at Turkey Point, primarily in and around the southern end of the cooling canals which lie south of the Turkey Point Unit 4 and Turkey Point Unit 6 areas. The majority of Turkey Point is considered American crocodile habitat due to the mobility of the species and use of the site for foraging, traversing, and basking. FPL manages a program for the conservation and enhancement of the American Crocodile and the program is credited with survival improvement and contributing to the downlisting of the American Crocodile from endangered to threatened.

Some listed flora species likely to occur at the site or vicinity include golden leather fern (*Acrostichum aureum*), pinelink (*Bletia purpurea*), Florida brickell-bush (*Brickellia mosieri*), Florida lantana (*Lantana depressa* var. *depressa*), mullein nightshade (*Solanum donianum*), and lamarck's trema (*Trema lamarckianum*).

During the construction and operation after construction, neither the Turkey Point Unit 4 EPU project nor the new Turkey Point Unit 6 project are expected to adversely affect any rare, endangered, or threatened species.

3. Natural Resources of Regional Significance Status

Significant features within the vicinity of the site include Biscayne National Park, the Biscayne Bay Aquatic Preserve, Miami-Dade County Homestead Bayfront Park, and Everglades National Park. The portion of Biscayne Bay adjacent to the site is included within the Biscayne National Park. Biscayne National Park contains 180,000 acres, approximately 95 percent of which is open water interspersed with more than 40 keys. The Biscayne National Park headquarters is located approximately two miles north of Turkey Point and is adjacent to the Miami-Dade County Homestead Bayfront Park, which contains a marina and day-use recreational facilities.

4. Other Significant Features

FPL is not aware of any other significant features of the site.

f. Design Features and Mitigation Options

In regard to the EPU project for Turkey Point Unit 4, this unit uses cooling water from a closed-loop cooling canal system to remove heat from the main (turbine) condensers, and to remove heat from other auxiliary equipment. The existing cooling canals will accommodate the slight increase in heat load that is associated with the increased capacity from the uprate. The maximum projected increase in water temperature entering the cooling canal system resulting from the nuclear uprate project is predicted to be about 3°F, from 106°F to 109°F. The associated projected maximum increase in water temperature returning to the unit is about 1°F, from 92°F to 93°F.

For Turkey Point Unit 6, the technology proposed is the Westinghouse AP1000 pressurized water reactor (PWR).⁷ This design is certified by the NRC under 10 CFR 52 and incorporates the latest technology and more advanced safety features than today's nuclear plants that have already achieved record safety levels. The Westinghouse AP1000 unit consists of the reactor, steam generators, pressurizer, and steam turbine/electric generator. Condenser cooling for the Unit 6 steam turbine will be accomplished using three circulating water cooling towers. The makeup water reservoir is the reinforced concrete structure beneath the circulating water system cooling towers that will contain reserve reclaimed water capacity to be used for the circulating water system. The structures for the Westinghouse AP1000 are the nuclear island (containment building, shield building, and auxiliary building), turbine building, annex building, diesel generator building, and radwaste building. The plant area will also contain the Clear Sky substation (switchyard) that will connect Unit 6 to FPL's transmission system.

g. Local Government future Land Use Designations

The Turkey Point Plant site is designated by the Miami-Dade County Comprehensive Development Management Plan as an IU-3 (Industrial, Utilities, and Communications) Unlimited Manufacturing District that carries a dual designation of MPA (Mangrove Protection Area) in portions of the property. There are also areas designated GU – "Interim District." Designations for the surrounding area are primarily GU – "Interim District."

⁷ Unless otherwise noted, the information presented for Turkey Point Unit 6 will also apply for Turkey Point Unit 7 whose currently projected in-service date is outside of the 2013-2022 reporting period addressed in this document.

h. Site Selection Criteria Process

The site has been selected as a Preferred Site for the EPU project for existing Unit 4 because it is an existing nuclear plant site and, therefore, offers the opportunity for increased nuclear capacity. For Turkey Point Unit 6, FPL conducted an extensive site selection analysis leading to the selection of the Turkey Point site as the site that, on balance, provided the most favorable location for developing new nuclear generation to serve FPL's customers. The Site Selection Study employed the principles of the Electric Power Research Institute (EPRI) siting guidelines and is modeled upon applicable NRC site suitability and National Environmental Policy Act (NEPA) criteria regarding the consideration of alternative sites. The study convened a group of industry and FPL subject matter experts to develop and assign weighting factors to a broad range of site selection criteria. Twenty-three candidate sites were then ranked using the siting criteria. This review allowed the list of candidates to be reduced until the best site emerged. Key factors contributing to the selection of the Turkey Point site include the existing transmission and transportation infrastructure to support new generation, the large size and seclusion of the site while being relatively close to the load center, and the long-standing record of safe and secure operation of nuclear generation at the site since the early 1970s.

i. Water Resources

Unique to Turkey Point is the closed-loop cooling canal system that supplies water to condense steam used by the plant's turbine generators. The canal system consists of 36 interconnected canals. The cooling canals occupy an area approximately two miles wide by five miles long (5,900 acres) and are approximately four feet deep. The system performs the same function as a car radiator. The water is circulated through the canals in a two-day journey, ending at the plant's intake pumps. The cooling canal system is utilized for cooling by Turkey Point Units 3 and 4 nuclear units.

In regard to Turkey Point Unit 6, the primary source of cooling water makeup will be reclaimed water from the Miami-Dade County Water and Sewer Department (MDWASD), with potable water also from MDWASD. When reclaimed water is not available in sufficient quantity and quality of water needed for cooling, makeup water will be saltwater supplied by radial collector wells that are recharged from the marine environment of Biscayne Bay. Horizontal collector wells (radial collector wells) have become widely used for the purpose of inducing infiltration from surface water bodies into hydraulically-connected aquifer systems in order to develop moderate to high capacity water supplies.

Turkey Point Unit 6 wastewater will be discharged via on-site deep injection wells.

j. Geological Features of Site and Adjacent Areas

Turkey Point lies upon the Floridian Plateau, a partly-submerged peninsula of the continental shelf. The peninsula is underlain by approximately 4,000 to 15,000 feet of sedimentary rocks consisting of limestone and associated formations that range in age from Paleozoic to Recent. Little is known about the basement complex of Paleozoic igneous and metamorphic rocks due to their great depth.

Generally in Miami-Dade County, the surficial aquifer (Biscayne Aquifer) consists of a wedge-shaped system of porous clastic and carbonate sedimentary materials, primarily limestone and sand deposits of the Miocene to late Quaternary age. The Biscayne Aquifer is thickest along the eastern coast and varies in thickness from 80 to 200 feet thick. The surficial aquifer is typically composed of Pamlico Sand, Miami Limestone (Oolite), the Fort Thompson and Anastasia Formations (lateral equivalents), Caloosahatchee Marl, and the Tamiami formation. The lower confining layers below the surficial aquifer range in thickness from 350 to 600 feet and are composed of the Hawthorn Group. Beneath the Hawthorn Group, the Floridan Aquifer System ranges from 2,800 to 3,400 feet thick and consists of Suwannee Limestone, Avon Park Limestone, and the Oldsmar Formations.

k. Projected Water Quantities for Various Uses

There will be no increase in the amount of water required due to the additional capacity that will result from the EPU project for existing Turkey Point Unit 4.

The estimated quantity of water required for the new Turkey Point Unit 6 for industrial processing is approximately 468 gallons per minute (gpm) for uses such as process water and service water. Approximately 27.7 million gallons per day (mgd) of cooling water would be cycled through the cooling towers. Water quantities needed for other uses such as potable water are estimated to be approximately 25,200 gallons per day (gpd) for Unit 6.

i. Water Supply Sources and Type

The source of cooling water for Turkey Point Unit 4 is the cooling canal system. There will be no increase in the amount of water withdrawn as a result of the additional capacity that will result from the EPU project. General plant service water, fire protection water, process water, and potable water are obtained from Miami-

Dade County. Process water uses include demineralizer regeneration, steam cycle makeup, and general service water use for washdowns. The water use for the facility will not change as a result of the EPU project.

In regard to Turkey Point Unit 6, the water for the various plant water needs will be obtained from a reclaimed water supply, a saltwater supply, and a potable water supply. Reclaimed water will be used as makeup water to the cooling water system with saltwater from radial collector wells as a back-up water source to be used when reclaimed water is not available in sufficient quantity or quality.

Potable water will be used as makeup water for the service water system. The potable water supply will also provide water to the fire protection system, demineralized water treatment system, and other miscellaneous uses.

m. Water Conservation Strategies

The existing water resources will not change as a result of the EPU project at Turkey Point Unit 4. Regarding Turkey Point Unit 6, use of reclaimed water from MDWASD is a beneficial and cost-effective means of increasing the use of reclaimed water. This use of reclaimed water helps Miami-Dade County meet approximately half of its wastewater reuse goals and will provide environmental benefits by reducing the volume of wastewater discharged by the County. In the absence of reuse opportunities, this treated domestic wastewater would likely continue to be discharged to the ocean or into deep injection wells.

Miami-Dade County is required to eliminate ocean outfalls and increase the amount of water that is reclaimed for environmental benefit and other beneficial uses. Turkey Point Unit 6 will use reclaimed water 24 hrs per day, 365 days per year when operating and water is available in sufficient quantity and quality.

n. Water Discharges and Pollution Control

Heated water discharges from Turkey Point Unit 4 are dissipated using the existing closed-loop cooling canal system. The additional generating capacity as a result of the EPU project for Turkey Point Unit 4 will not cause any changes in the quantity or characteristics of industrial wastewaters generated by the facility. Nor will the increased generating capacity at Turkey Point Unit 4 cause any changes in hydrologic or water quality conditions due to diversion, interception, or additions to surface water flow. The existing units at Turkey Point do not directly withdraw

groundwater under current operations and they will not do so after the EPU project is completed. Locally, groundwater is present beneath the site in the surficial or Biscayne Aquifer and in deeper aquifer zones that are part of the Floridan Aquifer System. There will be no effects on those deeper aquifer zones from the EPU project.

Turkey Point Unit 6 will dissipate heat from the power generation process using cooling towers. Blowdown water or discharge from the cooling towers, along with other wastestreams, will be injected into the boulder zone of the Floridan Aquifer. Non-point source discharges are not an issue since there will be none at this facility. Storm water runoff will be released to the closed-loop cooling canal system.

Turkey Point Unit 4 employs, and Turkey Point Unit 6 will employ, Best Management Practices (BMP) plans and Spill Prevention, Control, and Countermeasure (SPCC) plans to prevent and control the inadvertent release of pollutants.

o. Fuel Delivery, Storage, Waste Disposal, and Pollution Control

Turkey Point Unit 4 utilizes uranium-dioxide fuel that is slightly enriched uranium-235. The uranium-dioxide fuel is in the form of pellets contained in Zircaloy tubes with welded end plugs to confine radionuclides. The tubes are fabricated into assemblies designed for loading into the reactor core. Used fuel assemblies are stored in the onsite NRC-approved spent fuel storage facilities.

FPL currently replaces approximately one-third of the fuel assemblies in each reactor at refueling intervals of approximately 18 months. FPL operates each reactor such that the average fuel usage by a reactor is approximately 45,000 megawatt-days per metric ton of uranium. Following completion of the EPU project for Turkey Point Unit 4, more nuclear fuel will be used due to the increased generating capacity. No changes in the fuel handling facilities are required.

In regard to Turkey Point Unit 6, the reactor will contain enriched uranium fuel assemblies. A fuel assembly consists of 264 fuel rods in a 17-by-17 square array. The fuel rods consist of enriched uranium, in the form of cylindrical pellets of sintered uranium dioxide contained in ZIRLO™ tubing.

New fuel assemblies will be transported to Turkey Point for use in Unit 6 by truck from a fuel fabrication facility in accordance with U.S. Department of Transportation

(DOT) and NRC regulations. Spent fuel assemblies being discharged will remain in the spent fuel pool while short half-life isotopes decay.

After a sufficient decay period, the fuel would be transferred to an on-site independent spent fuel storage installation facility or an off-site disposal facility. Packaging of the fuel for off-site shipment will comply with the applicable DOT and NRC regulations for transportation of radioactive material.

The U.S. Department of Energy (DOE) is responsible for spent fuel transportation from reactor sites to a repository under the Nuclear Waste Policy Act of 1982, as amended. FPL has executed a standard spent nuclear fuel disposal contract with DOE for fuel used in Unit 6.

At Turkey Point Unit 4 diesel fuel is used in a number of emergency generators that include four main emergency generators, five smaller emergency generators, and various general purpose diesel engines. The emergency generators will not be changed as a result of the EPU project. These emergency generators are for stand-by use only and only operated for testing purposes to assure reliability and for maintenance. Diesel fuel for the emergency generators is delivered to Turkey Point by truck as needed, and stored in tanks with secondary containment.

p. **Air Emissions and Control Systems**

The normal operation of Turkey Point Unit 4 does not create fossil fuel-related air emissions. However, there are emergency generators associated with Unit 4. Four of these nine emergency generators are main plant emergency generators which are rated at 2.5 MW each. The remaining five generators are smaller emergency generators which are associated with the security system. In addition, various general purpose diesels are used as needed. No additional generators are required as part of the EPU project for Turkey Point Unit 4.

The Turkey Point Unit 4 associated emergency generators and diesel engines, together with Turkey Point Units 1, 2, and 5, are classified as a major source of air pollution. FDEP has issued a separate Title V Air Operating Permit for Turkey Point (Permit Number 0250003-004-AV). There are no operating limits for the emergency generators or diesel engines. Emergency diesel generators are limited to use ultra-low sulfur diesel fuel (0.0015% sulfur). NO_x emissions are regulated under Reasonably Available Control Technology (RACT) requirements in Rule 62-296.570(4) (b) 7 F.A.C., which limit NO_x emissions to 4.75 lb/MMBtu. The use of 0.05

percent sulfur diesel fuel and good combustion practices serve to keep NO_x emissions under this limit.

Regarding Turkey Point Unit 6, the unit will also minimize FPL system air pollutant emissions by using nuclear fuel to generate electric power. This includes avoiding emissions of particulate matter (PM), sulfur dioxide (SO₂), nitrogen oxides (NO_x), carbon monoxide (CO), carbon dioxide (CO₂), and volatile organic compounds (VOC). The circulating water cooling towers will be equipped with high-efficiency drift or mist eliminators to minimize emissions of PM to 0.0005 percent of the circulating water; this is over 99.99-percent control of potential drift emissions based on the circulating water flow.

The diesel engines necessary to support Turkey Point Unit 6 and fire pump engines will be purchased from manufacturers whose engines meet the EPA's NSPS Subpart III emission limits.

q. Noise Emissions and Control Systems

Field surveys and impact assessments of noise expected to be caused by activities associated with the Turkey Point Unit 4 EPU project and the Turkey Point Unit 6 project were conducted. Predicted noise levels associated with these projects are not expected to result in adverse noise impacts in the vicinity of the site.

r. Status of Applications

The Turkey Point Unit 4, EPU Site Certification Application (SCA), under the Florida Electrical Power Plant Siting Act, was filed in January 2008 and a final order was issued in October 2008. The FPSC voted to approve the need for additional generating capacity at Turkey Point and the final order approving the need for this additional nuclear capacity was issued in January 2008. In addition, a License Amendment request for the EPU was submitted to the NRC in October 2010. The License Amendment was approved in June 2012.

The Turkey Point Unit 6 Site Certification Application (SCA), under the Florida Electrical Power Plant Siting Act, was filed in June 2009 and a final order is currently expected in January 2014. The FPSC issued the final order approving the need for this additional nuclear capacity in April 2008.

A License Amendment request for Unit 6 was submitted to the NRC in June 2009. There are two components to that application; one is the Environmental Assessment (EA) and the other is the Safety component. The Application is still in process.

Besides the certification and the license amendment, additional permits have been issued for Turkey Point Units 6 & 7 including Miami-Dade County Unusual Use approvals that were issued in 2007 and 2013 and the Prevention of Significant Deterioration (Air permit) that was issued in 2009. In addition, a permit to construct an exploratory well and a dual zone monitoring well, under the Underground Injection Control Program, was issued in 2010. Permits from the FAA for the containment structure were originally issued in 2009 and renewed in 2012.

Preferred Site # 2: Cape Canaveral Plant, Brevard County

This site is located on the existing FPL Cape Canaveral Plant property in unincorporated Brevard County. The site is bound to the east by the Indian River Lagoon and on the west by a four-lane highway (U.S. Highway 1). The city of Port St. Johns is located less than a mile away. A rail line is located near the plant.

The site previously housed two steam generating units (Units 1 & 2) with 788 MW (Summer) of generating capacity. The units formerly occupied a portion of the 43 acres that are wholly owned by FPL. FPL is in the process of modernizing the existing Cape Canaveral Plant, to be renamed the Cape Canaveral Next Generation Clean Energy Center (CCEC), by replacing the previous two steam generating units with a single modern, highly efficient, lower-emission next-generation clean energy center using advanced CC technology. The old units have been taken out of service and dismantled. The demolition of the Cape Canaveral Plant began in mid-2010 and was completed during the first quarter of 2011. Construction for the new CC unit began in March 2011 and is expected to be completed by June 2013.

a. **Geological Survey (USGS) Map**

A USGS map of the CCEC site is found at the end of this chapter.

b. **Proposed Facilities Layout**

A map of the general layout of the CCEC generating facilities at the site is found at the end of this chapter.

c. **Map of Site and Adjacent Areas**

An overview map of the site and adjacent areas is also found at the end of this chapter.

d. **Existing Land Uses of Site and Adjacent Areas**

The existing and future land uses on the site are primarily dedicated to electrical generation; i.e., FPL's former Cape Canaveral Units 1 & 2 and the future CCEC unit. The existing land uses that are adjacent to the site consist of single- and multi-family residences to the south and southwest, commercial property to the northwest, utility systems to the west, and a private medical/office facility to the north.

e. **General Environment Features On and In the Site Vicinity**

1. **Natural Environment**

The natural environment surrounding the site includes the Indian River Lagoon to the east and upland scrub, pine and hardwoods to the north and south. Vegetation within the approximately 45-acre offsite construction laydown and parking area (located west of U.S. Highway 1) consists of open land, upland scrub, pine, hardwoods along with exotic plant species.

2. **Listed Species**

No adverse impacts to federally or state-listed terrestrial plants and animals are expected in association with construction of the CCEC at the site, due to the existing developed nature of the site and lack of suitable habitat for listed species. Federal- or state-listed terrestrial plants and animals inhabiting the offsite construction laydown and parking area are limited to the state-listed gopher tortoise and the state- and federally-listed scrub jay. The warm water discharges from the plant attract manatees, an endangered species. FPL continues to work closely with state and federal wildlife agencies to ensure protection of the manatees during the modernization process. In 2010, FPL installed a temporary heating system to warm the water for the manatees as required during manatee season. FPL has complied, and will continue to comply, with several other manatee-related conditions of certification to ensure the protection of the manatees during the modernization work and during subsequent operation of the new generating facility.

3. Natural Resources of Regional Significance Status

The construction and operation of the CCEC at this location is consistent with the existing use at the site and is not expected to have any adverse impacts on parks, recreation areas, or environmentally sensitive lands.

4. Other Significant Features

FPL is not aware of any other significant features of the site.

f. Design Features and Mitigation Options

The design option is to replace the previous steam generating units (Units 1 & 2) with one new 1,210 MW (Summer) CC unit consisting of three new combustion turbines (CTs), three new heat recovery steam generators (HRSG), and a new steam turbine. The new CC unit is projected to be in-service in mid-2013. Natural gas delivered via pipeline is the primary fuel type for this unit with ultra-low sulfur light fuel oil serving as a backup fuel.

g. Local Government Future Land Use Designations

Local government future land use designation for the site is "Public Utilities" and the area has been rezoned to GML-U. Designations for the surrounding area are primarily "Community Commercial" and "Residential". A land use map of the site and adjacent areas is also found at the end of this chapter.

h. Site Selection Criteria Process

The Cape Canaveral Plant site was selected for a site modernization due to consideration of various factors including system load and economics. Environmental issues were not a significant factor since this site was the site of a previous power plant and does not exhibit significant environmental sensitivity or other environmental issues. However, the significant reduction in cooling water withdrawal and thermal component of cooling water discharges are environmental benefits of replacing the previous steam units with a new CC unit. Other environmental benefits include a significant reduction in system fuel use, a significant reduction in system air emissions, improved aesthetics at the site, and continued warm water discharge for the manatees as required during manatee season. Further, modernizing this existing facility reduces the impact on natural resources by not requiring new land, new water sources, or additional off-site transmission siting.

i. **Water Resources**

Condenser cooling for the steam cycle portion of the new plant and auxiliary cooling will come from the existing cooling water intake system. Process, potable, and reclaimed water for the new plant will come from the existing City of Cocoa's potable water supply.

j. **Geological Features of Site and Adjacent Areas**

The site is located on the Atlantic Coastal Ridge and is at an approximate elevation of 12 feet above mean sea level (msl). The land consists primarily of fine to medium sand that parallels the coast. There is a lack of shell as it was deposited during a time of transgression. The base of the sedimentary rocks is made up of a thick, primarily carbonate sequence deposited during the Jurassic age through the Pleistocene age. Starting in the Miocene age and continuing through the Holocene age, siliciclastic sedimentation became more predominant. The basement rocks in this area consist of low-grade metamorphic and igneous intrusives, which occur several thousand feet below land surface and are Precambrian, Paleozoic, and Mesozoic in age.

k. **Projected Water Quantities for Various Uses**

The estimated quantity of water required for processing is approximately 0.232 million gallons per day (mgd) for uses such as process water and service water. Potable water demand is expected to average .001 mgd. Approximately 600 mgd of cooling water would be cycled through the once-through cooling water system.

l. **Water Supply Sources by Type**

The modernized plant will continue to use the Indian River Lagoon water as the source of once-through cooling water. Such needs for cooling water will comply with the St. John's River Water Management District (SJRWMD) conditions in the site certification. Process and potable water for the new plant will come from the existing City of Cocoa's potable water supply. Reclaimed water may be used for irrigation.

m. **Water Conservation Strategies Under Consideration**

No additional water resources will be required as a result of the modernization project. CC technology uses less water by design than traditional steam generation units.

n. **Water Discharges and Pollution Control**

The modernized site will utilize portions of the existing once-through cooling water systems for heat dissipation. The heat recovery steam generator blowdown (wastewater discharge required to maintain process water quality) will be reused to the maximum extent practicable or mixed with the cooling water flow before discharge. Reverse osmosis (R/O) reject will be mixed with the plant's once-through cooling water system. Storm water runoff will be collected and routed to storm water ponds. The facility will employ a Best Management Practices (BMP) plan and Spill Prevention, Control, and Countermeasure (SPCC) plan to prevent and control the inadvertent release of pollutants.

o. **Fuel Delivery, Storage, Waste Disposal, and Pollution Control**

Natural gas for the new unit will be transported to the site via a pipeline. New off-site gas compressors will be used to raise the gas pressure of the existing pipeline for the new unit. Ultra-low sulfur light fuel oil will be received by truck or barge from Port Canaveral and stored in an above-ground storage tank.

p. **Air Emissions and Control Systems**

The emission rates of CCEC would decrease by over 90% from the former Cape Canaveral Plant, resulting in substantial annual emission reductions and increased air quality benefits per unit of energy produced. The use of natural gas, ultra-low sulfur light fuel oil, and combustion controls would minimize air emissions from the CC unit and ensure compliance with applicable emission limiting standards. Using these clean fuels minimizes emissions of sulfur dioxide (SO₂), particulate matter, and other fuel-bound contaminants. Combustion controls similarly minimize the formation of nitrogen oxides (NO_x) and the combustor design will limit the formation of carbon monoxide and volatile organic compounds. When firing natural gas, NO_x emissions will be controlled using dry-low NO_x combustion technology and selective catalytic reduction (SCR). Water injection and SCR will be used to reduce NO_x emissions during operations when using ultra-low sulfur light fuel oil as backup fuel. These design alternatives are equivalent to the Best Available Control Technology for air emissions, and minimize such emissions while balancing economic, environmental, and energy impacts. CC facility emissions of greenhouse gases (GHGs) from combustion of natural gas achieve an emission rate substantially lower than the EPA proposed new source performance standards for GHGs. In total, the design of the new CCEC plant will incorporate features that would make it among the most efficient and cleanest power plants in the State of Florida.

q. **Noise Emissions and Control Systems**

Noise expected to be caused by unit construction at the site is expected to be below current noise levels for the residents nearest the site. Noise from the operation of the new unit will be within allowable levels.

r. **Status of Applications**

The FPSC voted to approve the need for the modernization project and the need order was issued in September 2008. The project received final state certification on October 9, 2009, through the issuance of a final order signed by the Secretary of the Department of Environmental Protection (DEP).

Preferred Site # 3: Riviera Beach Plant, Palm Beach County

This site is located on the former FPL Riviera Beach Plant property primarily within Riviera Beach, Palm Beach County (with a small portion of the Site in West Palm Beach). The site is bound to the east by the Lake Worth Lagoon (Intracoastal Waterway) and on the west by a four-lane highway (U.S. Highway 1). The site has barge access via the Port of Palm Beach. A rail line is located near the plant.

The previous site generating capacity was made up of two 300 MW (approximate) steam generating units (Units 3 & 4) that were taken out of service and dismantled in 2011. Units 1 & 2 were previously retired and dismantled and are no longer on the plant site.

FPL is in the process of modernizing the former Riviera Beach Plant, to be renamed the Riviera Beach Next Generation Clean Energy Center (RBEC), by replacing the existing generating units with a modern, highly efficient, lower-emission next-generation clean energy center using advanced CC technology.

a. **U.S. Geological Survey (USGS) Map**

A USGS map of the RBEC site is found at the end of this chapter.

b. **Proposed Facilities Layout**

A general layout of the RBEC generating facilities is found at the end of this chapter.

c. **Map of Site and Adjacent Areas**

An overview map of the site and adjacent areas is also found at the end of this chapter.

d. Existing Land Uses of Site and Adjacent Areas

The previous Riviera Beach Plant consisted of two 300 MW (approximate) units with conventional dual-fuel fired steam boilers and steam turbine units. The plant site includes minimal vegetation and a landscape buffer area south of the power plant. Adjacent land uses include port facilities and associated industrial activities, as well as light commercial and residential development.

e. General Environment Features On and In the Site Vicinity

1. Natural Environment

The existing FPL Riviera Beach Plant property is located on approximately 46 acres of flat, sandy soils on the west side of the Intracoastal Waterway. The majority of the site is comprised of seven acres containing transmission lines and facilities on the west side of U.S. Highway 1, and 39 acres comprised of facilities related to electric power generation on the east side of U.S. Highway 1. The site provides warm water as required for manatees pursuant to the facility's Manatee Protection Plan.

2. Listed Species

No adverse impacts to federally or state-listed terrestrial plants and animals are expected in association with construction at the site, due to the existing developed nature of the site and lack of suitable onsite habitat for listed species. The warm water discharges from the plant attract manatees, an endangered species. FPL continues to work closely with state and federal wildlife agencies to ensure protection of the manatees during the modernization process. In 2009, FPL installed a temporary heating system to warm the water for the manatees as required pursuant to the facility's Manatee Protection Plan. FPL will also be complying with several other manatee-related conditions of certification to ensure the protection of the manatees during the modernization work and during operation of the RBEC.

3. Natural Resources of Regional Significance Status

The construction and operation of a natural gas-fired CC generating facility at this location is consistent with the existing use at the site and is not expected to have any adverse impacts on parks, recreation areas, or environmentally sensitive lands.

4. Other Significant Features

FPL is not aware of any other significant features of the site.

f. Design Features and Mitigation Options

The design option is to replace the previous steam generating units (Units 3 & 4) with one new 1,212 MW (Summer) CC unit consisting of three new CTs, three new heat recovery steam generators (HRSG), and a new steam turbine. The new CC unit is projected to be in service in mid-2014. Natural gas delivered via pipeline is the primary fuel type for the unit with ultra-low sulfur light fuel oil serving as a backup fuel.

g. Local Government Future Land Use Designations

Local government future land use designation for the site is "Utility". The Port of Palm Beach is to the north of the site. Designation to the west of the site is "Commercial." To the south of the site is "Residential" and is in the City of West Palm Beach. A land use map of the site and adjacent areas is also found at the end of this chapter.

h. Site Selection Criteria Process

This site has been selected for site modernization due to consideration of various factors including system load and economics. Environmental issues were not a deciding factor since this site does not exhibit significant environmental sensitivity or other environmental issues. However, there are environmental benefits of replacing the existing steam units with a new CC unit including a significant reduction in system air emissions, improved aesthetics at the site, and continued warm water discharge for the manatees as required during manatee season. Further, modernizing this existing facility reduces the impact on natural resources by not requiring new land or new water resources.

i. Water Resources

Water from the Lake Worth Lagoon (Intracoastal Waterway) will be used for once-through cooling water. RBEC will utilize portions of the existing once-through cooling water intake and discharge structures. Water for cooling pump seals and irrigation will come from three onsite surficial aquifer wells. Process and potable water for the converted plant will come from the existing City of Riviera Beach potable water supply.

j. Geological Features of Site and Adjacent Areas

The site is underlain by the surficial aquifer system. The surficial aquifer system in eastern Palm Beach County is primarily composed of sand, sandstone, shell, silt, calcareous clay (marl), and limestone deposited during the Pleistocene and Pliocene Epochs. The sediments forming the aquifer system are the Pamlico Sand, Fort Thompson Formation (Pleistocene) and the Caloosahatchee Marl (Pleistocene and Pliocene). Permeable sediments in the upper part of the Tamiami Formation (Pliocene) are also part of the aquifer system.

The surficial aquifer is underlain by at least 600 feet of the Hawthorn formation (confining unit). The Floridan Aquifer System underlies the Hawthorn formation.

k. Projected Water Quantities for Various Uses

The estimated quantity of water required for processing is approximately 0.232 million gallons per day (mgd) for uses such as process water and service water. Approximately 600 mgd of cooling water would be cycled through the once-through cooling water system. Potable water demand is expected to average .001 mgd.

l. Water Supply Sources by Type

The modernized plant will continue to use Lake Worth Lagoon water as the source of once-through cooling water. Water for cooling pump seals and irrigation will come from on-site surficial aquifer wells currently authorized under SFWMD conditions of certification. Process and potable water for the new plant will come from the existing City of Riviera Beach's potable water supply.

m. Water Conservation Strategies Under Consideration

No additional water resources will be required as a result of the modernization project. CC technology uses less water by design than traditional steam generation units.

n. Water Discharges and Pollution Control

The modernized plant will utilize portions of the existing once-through cooling water system for heat dissipation. The heat recovery steam generator blowdown will be mixed with the cooling water flow before discharge. Reverse osmosis (R/O) reject will be mixed with the plant's once-through cooling water system prior to discharge. Storm water runoff will be collected and routed to storm water ponds. The facility will employ a Best Management Practices (BMP) plan and Spill Prevention, Control, and

Countermeasure (SPCC) plan to prevent and control the inadvertent release of pollutants.

o. Fuel Delivery, Storage, Waste Disposal, and Pollution Control

Natural gas for the new unit would be transported to the site via an approximately six mile FPL-owned pipeline and a 32 mile pipeline from the Martin Plant. Together, the two pipelines are known as the RBEC Lateral. New gas compressors will be installed at the existing FPL 45th Street Terminal facility in Riviera Beach to raise the gas pressure of the pipeline to the appropriate level for the new unit. Ultra-low sulfur light fuel oil would be received by truck, pipeline, or barge and stored in a new above-ground storage tank.

p. Air Emissions and Control Systems

The regulated air emission rates at the new plant would be more than 90 percent lower than the previous Riviera Beach Plant's emission rates, resulting in significant annual emissions reductions and air quality benefits per unit of energy produced. The use of natural gas, ultra-low sulfur light fuel oil, and combustion controls would minimize air emissions from the unit and ensure compliance with applicable emission limiting standards. Using these fuels minimizes emissions of sulfur dioxide (SO₂), particulate matter, and other fuel-bound contaminants. Combustion controls similarly minimize the formation of nitrogen oxides (NO_x) and the combustor design will limit the formation of carbon monoxide and volatile organic compounds. When firing natural gas, NO_x emissions will be controlled using dry-low NO_x combustion technology and selective catalytic reduction (SCR). Water injection and SCR will be used to reduce NO_x emissions during operations when using ultra-low sulfur light fuel oil as backup fuel. These design alternatives are equivalent to the Best Available Control Technology for air emissions, and minimize such emissions while balancing economic, environmental, and energy impacts. CC facility emissions of GHGs from combustion of natural gas achieve an emission rate substantially lower than the EPA proposed new source performance standards for GHGs. Taken together, the design of RBEC would incorporate features that will make it among the most efficient and cleanest power plants in the State of Florida.

q. Noise Emissions and Control Systems

Noise expected to be caused by unit construction at the site is expected to be below current noise levels for the residents nearest the site. Noise from the operation of the new unit will be within allowable levels.

r. **Status of Applications**

The FPSC voted to approve the need for the modernization project and the need order was issued in September 2008. The project received final state certification on November 24, 2009, through the issuance of a final order signed by the Secretary of the DEP. The project received final certification for the RBEC Lateral and compressor station on March 15, 2011.

Preferred Site # 4: Port Everglades Plant, Broward County

This site is located on the existing FPL Port Everglades Plant property within the City of Hollywood, Broward County. The site is surrounded by the Port of Port Everglades. The site has barge access via the Port of Port Everglades. A rail line is located near the plant.

The previous site generating capacity was made up of two 200 MW (approximate) steam generating units (Units 1 & 2) and two 400 MW (approximate) steam generating units (Units 3 & 4). The four units will be taken out of service and dismantled by mid-2013 as part of the modernization of the plant site.

The Port Everglades Plant site has been listed as a Potential Site in previous FPL Site Plans for both CC and CT generation options. On April 9, 2012, the FPSC issued the final need order for the modernization of the existing Port Everglades Plant. As a result of the modernization of the site, the new generating unit - to be renamed the Port Everglades Next Generation Clean Energy Center (PEEC) – will replace the existing steam generating units with a modern, highly efficient, lower-emission next-generation clean energy center using advanced CC technology. The existing four steam units will first be removed from the site and will be replaced by a single new CC unit.

a. **U.S. Geological Survey (USGS) Map**

A USGS map of the PEEC site is found at the end of this chapter.

b. **Proposed Facilities Layout**

A general layout of the PEEC generating facilities is found at the end of this chapter.

c. **Map of Site and Adjacent Areas**

An overview map of the site and adjacent areas is also found at the end of this chapter.

d. Existing Land Uses of Site and Adjacent Areas

The existing Port Everglades Plant consists of two 200 MW (approximate) and two 400 MW (approximate) generating units with conventional dual-fuel fired steam boilers and steam turbine units. The plant site includes minimal vegetation. Adjacent land uses include port facilities and associated industrial activities, as well as light commercial and residential development.

e. General Environment Features On and In the Site Vicinity

1. Natural Environment

The majority of the site is comprised of facilities related to electric power generation for the existing Port Everglades Plant generating units. The site is located adjacent to the Intracoastal Waterway. The site provides warm water as required for manatees pursuant to the facility's Manatee Protection Plan.

2. Listed Species

No adverse impacts to federally or state-listed terrestrial plants and animals are expected in association with construction at the site, due to the existing developed nature of the site and lack of suitable onsite habitat for listed species. The warm water discharges from the plant attract manatees, an endangered species. FPL continues to work closely with state and federal wildlife agencies to ensure protection of the manatees during the modernization process and upon operation of the new plant. FPL plans to install a temporary heating system to provide warm water for manatees as required pursuant to the facility's Manatee Protection Plan. FPL also anticipates complying with other manatee-related conditions of certification to ensure the protection of the manatees during the modernization work and during future operations of PEEC.

3. Natural Resources of Regional Significance Status

The construction and operation of a natural gas-fired CC generating facility at this location is consistent with the existing use at the site and is not expected to have any adverse impacts on parks, recreation areas, or environmentally sensitive lands.

4. Other Significant Features

FPL is not aware of any other significant features of the site.

f. Design Features and Mitigation Options

The design option is to replace the existing units (Units 1 through 4) with one new 1,277 MW (Summer) unit consisting of three new CTs, three new heat recovery steam generators (HRSG), and a new steam turbine. The new CC unit is projected to be in service in mid-2016. Natural gas delivered via the existing pipeline is the primary fuel type for the unit with ultra-low sulfur light fuel oil serving as a backup fuel.

g. Local Government Future Land Use Designations

Local government future land use designation for the site is a combination of “Electrical Generating Facility” and “Utilities Use”. A land use map of the site and adjacent areas is also found at the end of this chapter.

h. Site Selection Criteria Process

The Port Everglades Plant has been selected for site modernization due to consideration of various factors including system load, ability to provide generation in the Miami-Dade/Broward region to help balance load and generation in the region, and economics. Environmental issues were not a deciding factor since this site does not exhibit significant environmental sensitivity or other environmental issues. However, there are environmental benefits of replacing the existing steam units with a new CC unit including a significant reduction in system air emissions, improved aesthetics at the site, and continued warm water discharge for the manatees as required pursuant to the facility’s Manatee Protection Plan. Further, modernizing this existing facility reduces the impact on natural resources by not requiring new land or new water resources.

i. Water Resources

Water from the Intracoastal Waterway via the Port of Port Everglades Slip No. 3 is currently used for once-through cooling water supply. The new plant will utilize portions of the existing once-through cooling water intake and discharge structures. Process and potable water for the modernized plant will come from the existing City of Ft. Lauderdale potable water supply.

j. Geological Features of Site and Adjacent Areas

FPL’s Port Everglades Plant site is underlain by the surficial aquifer system. The surficial aquifer system in eastern Broward County is primarily composed of sand, sandstone, shell, silt, calcareous clay (marl), and limestone deposited during the

Pleistocene and Pliocene ages. The sediments forming the aquifer system are the Pamlico Sand, Miami Oolite, Anastasia Formation, Key Largo Formation, and Fort Thompson Formation (Pleistocene) and the Tamiami Formation (Pliocene). The sediments in the eastern portion of the county are appreciably more permeable than in the west.

The surficial aquifer is underlain by at least 600 feet of the Hawthorn formation (confining unit). The Floridan Aquifer System underlies the Hawthorn formation.

k. Projected Water Quantities for Various Uses

The estimated quantity of water required for processing is approximately 0.24 million gallons per day (mgd) for uses such as process water and service water. Approximately 600 mgd of cooling water would be cycled through the once-through cooling water system which is a reduction of more than 51% from the previous fossil steam unit's capability. Potable water demand is expected to average .001 mgd.

l. Water Supply Sources by Type

The modernized plant will continue to use the Intracoastal Waterway as the source of once-through cooling water. Process and potable water for the new plant will come from the existing City of Ft. Lauderdale potable water supply.

m. Water Conservation Strategies Under Consideration

No additional water resources will be required as a result of the modernization project. CC technology uses less water by design than traditional steam generation units.

n. Water Discharges and Pollution Control

The modernized plant will utilize portions of the existing once-through cooling water system for heat dissipation. The heat recovery steam generator blowdown will be reused to the maximum extent practicable or mixed with the cooling water flow before discharge. Reverse osmosis (R/O) reject will be mixed with the plant's once-through cooling water system prior to discharge. Stormwater runoff will be collected and routed to stormwater ponds. The facility will employ a Best Management Practices (BMP) plan and Spill Prevention, Control, and Countermeasure (SPCC) plan to prevent and control the inadvertent release of pollutants.

o. Fuel Delivery, Storage, Waste Disposal, and Pollution Control

Natural gas for the new unit would be transported to the site via an existing natural gas pipeline to the site. New gas compressors to raise the gas pressure of the pipeline to the appropriate level for the new unit will be installed either at the existing site or off-site. Ultra-low sulfur light fuel oil would be received by truck, pipeline, or barge and stored in a new above-ground storage tank.

p. Air Emissions and Control Systems

The regulated air emission rates at the new plant would be approximately 90 percent lower than the previous Port Everglades Plant's emission rates, resulting in significant annual emissions reductions and air quality benefits per unit of energy produced. The use of natural gas, ultra-low sulfur light fuel oil, and combustion controls would minimize air emissions from the unit and ensure compliance with applicable emission limiting standards. Using these fuels minimizes emissions of sulfur dioxide (SO₂), particulate matter, and other fuel-bound contaminants. Combustion controls similarly minimize the formation of nitrogen oxides (NO_x) and the combustor design will limit the formation of carbon monoxide and volatile organic compounds. When firing natural gas, NO_x emissions will be controlled using dry-low NO_x combustion technology and selective catalytic reduction (SCR). Water injection and SCR will be used to reduce NO_x emissions during operations when using ultra-low sulfur light fuel oil as backup fuel. CC facility emissions of GHGs from combustion of natural gas achieve an emission rate substantially lower than the EPA proposed new source performance standards for GHGs. These design alternatives are equivalent to the Best Available Control Technology for air emissions, and minimize such emissions while balancing economic, environmental, and energy impacts. Taken together, the design of PEEC would incorporate features that will make it among the most efficient and cleanest power plants in the State of Florida.

q. Noise Emissions and Control Systems

Noise expected to be caused by unit construction at the site is expected to be below current noise levels for the residents nearest the site.

r. Status of Applications

FPL filed a need determination with the FPSC on November 21, 2011. The FPSC's final need order was issued on April 9, 2012. The Site Certification Application (SCA) was submitted January 24, 2012 resulting in the issuance of Final Order PA 12-57 on

October 9, 2012. Concurrent with the SCA filing, FPL submitted applications for a Greenhouse Gas permit, a Prevention of Significant Deterioration permit and an Industrial Wastewater Facility permit revision. The revised Industrial Wastewater Facility permit was issued December 16, 2012.

Preferred Site # 5: Hendry County, Hendry County

FPL has acquired an approximately 3,120-acre site in southeast Hendry County, off CR 833. The Hendry County site has been listed as a Potential Site in previous FPL Site Plans as a possibility for a future PV facility and/or natural gas-fired CC generation. FPL currently views the Hendry site as one of the most likely sites to be used for large-scale generation additions at some future date after the last of the three modernization projects are completed in 2016.

a. **Geological Survey (USGS) Map**

A USGS map of the site is found at the end of this chapter.

b. **Proposed Facilities Layout**

A map of the property owned by FPL is found at the end of this chapter.

c. **Map of Site and Adjacent Areas**

An overview map of the site and adjacent areas is also found at the end of this chapter.

d. **Existing Land Uses of Site and Adjacent Areas**

The existing and future land uses on the site are zoned Utility. The existing land uses that are adjacent to the site are predominately agricultural. The property to the south is the Seminole Big Cypress Reservation.

e. **General Environment Features On and In the Site Vicinity**

1. **Natural Environment**

The natural environment adjacent to the north, east, and west of the site are used predominately for agricultural activities such as improved, unimproved, and woodland pasture. The majority of the pasture lands includes upland scrub, pine, and hardwoods. The Seminole Big Cypress Reservation lies to the south.

2. Listed Species

FPL strives to have no adverse impacts on federal- or state-listed terrestrial plants and animals. Much of southwest Florida is considered habitat for the endangered Florida Panther. Although few or no impacts are expected in association with future construction at the site, FPL anticipates minimizing or mitigating for unavoidable wildlife or wetland impacts.

3. Natural Resources of Regional Significance Status

Future construction and operation of a solar and/or a natural gas-fired CC generating facility at this location is not expected to have any adverse impacts on parks, recreation areas, or environmentally sensitive lands.

4. Other Significant Features

FPL is not aware of any other significant features of the site.

f. Design Features and Mitigation Options

Options include construction of CC and/or solar power generation technologies. Mitigation for unavoidable impacts may occur through a combination of on- and off-site mitigation.

g. Local Government Future Land Use Designations

Local government future land use designation for the site is Utility. A land use map of the site and adjacent areas is also found at the end of this chapter.

h. Site Selection Criteria Process

The Hendry County site has been selected as "Preferred" due to consideration of various factors including system load, transmission interconnection, and economics.

i. Water Resources

Groundwater is anticipated to supply water to the Hendry County site.

j. Geological Features of Site and Adjacent Areas

The site is at an approximate elevation of 10 to 12 feet above mean sea level (msl) and is located on the Immokalee Rise and the Big Cypress Spur considered terraces created by high sea level events. The terraces are composed of fine quartz sands that lie discontinuously upon the surficial aquifer system whose sediments are the Fort Thompson (Pleistocene), Caloosahatchee Marl (Pleistocene and Pliocene), and

Tamiami Formations (Pliocene). Other soil types in the area include limestone rock, calcareous muds, sands, organic materials, and mixed solids.

The surficial aquifer is underlain by the Hawthorn formation (confining unit). The Floridan Aquifer System underlies the Hawthorn formation.

k. Projected Water Quantities for Various Uses

The estimated quantity of water required for processing at a CC unit is approximately 0.24 million gallons per day (mgd) for uses such as process water and service water. Potable water demand is expected to average .001 mgd. Minimal amounts of water would be required for a PV facility. Approximately 7.5 mgd of cooling water would be used in cooling towers for one CC unit.

l. Water Supply Sources by Type

Potential water supply source is groundwater. Additional evaluations are necessary to determine the exact source.

m. Water Conservation Strategies Under Consideration

CC and cooling tower technologies withdraw less water by design than traditional steam generation units. Some solar technologies do not require water for process or cooling purposes. Specific water conservation strategies will be evaluated and selected during the detailed design phase of any development project.

n. Water Discharges and Pollution Control

A CC unit at the site will utilize a closed cycle cooling (towers) system for heat dissipation. The heat recovery steam generator blowdown will be reused to the maximum extent practicable or mixed with the cooling water flow before discharge. Reverse osmosis (R/O) reject will be mixed with the plant's cooling water flow prior to discharge. Wastewater disposal is anticipated via discharge to an Underground Injection Control well system. Stormwater runoff would be collected and routed to stormwater ponds. The facility will employ a Best Management Practices (BMP) plan and Spill Prevention, Control, and Countermeasure (SPCC) plan to prevent and control the inadvertent release of pollutants.

o. Fuel Delivery, Storage, Waste Disposal, and Pollution Control

Natural gas for a new CC unit will be transported to the site via a new natural gas pipeline lateral to the site. New gas compressors to raise the gas pressure of the

pipeline to the appropriate level for the new unit may be necessary. Ultra-low sulfur light fuel oil will be received by truck or pipeline and stored in an above-ground storage tank.

p. Air Emissions and Control Systems

The use of natural gas, ultra-low sulfur light fuel oil, and combustion controls would minimize regulated air emissions from a CC unit and ensure compliance with applicable emission limiting standards. Using these clean fuels minimizes emissions of SO₂, PM, and other fuel-bound contaminants. Combustion controls similarly minimize the formation of NO_x and the combustor design will limit the formation of CO and VOCs. When firing natural gas, NO_x emissions will be controlled using dry-low NO_x combustion technology and selective catalytic reduction (SCR). Water injection and SCR will be used to reduce NO_x emissions during operations when using ultra low sulfur fuel oil as backup fuel. CC facility emissions of GHGs from combustion of natural gas achieve an emission rate substantially lower than the EPA proposed new source performance standards for GHGs. These design alternatives are equivalent to the Best Available Control Technology for air emissions, and minimize such emissions while balancing economic, environmental, and energy impacts. Taken together, the design of a CC unit would incorporate features that will make it among the most efficient and cleanest power plants in the State of Florida. PV generation does not produce air emissions.

q. Noise Emissions and Control Systems

Noise anticipated to be caused by unit construction at the site is expected to be minimal.

r. Status of Applications

FPL has not submitted any application associated with the Hendry County site.

Preferred Site # 6: NE Okeechobee County, Okeechobee County

FPL has purchased a site of approximately 2,800 acres in Northeast Okeechobee County. The site is in an unincorporated, rural area and is predominantly used for agricultural production. FPL's transmission lines intersect the property. The Northeast Okeechobee County site has been listed as a Potential Site in previous FPL Site Plans as a possibility for a future PV facility or natural gas-fired CC generation. FPL currently views the Okeechobee site as one of the most likely sites to be used for large-scale

generation additions at some future date after the last of the three modernization projects are completed in 2016.

a) **U.S. Geological Survey (USGS) Map**

A USGS map of the Northeast Okeechobee site is found at the end of this chapter.

b) **Proposed Facilities Layout**

A map of the property owned by FPL is found at the end of this chapter.

c) **Map of Site and Adjacent Areas**

An overview map of the site and adjacent areas is also found at the end of this chapter.

d) **Existing Land Uses of Site and Adjacent Areas**

The Northeast Okeechobee County site is predominantly used for agricultural production (cattle and citrus). Adjacent land uses include primarily agriculture and conservation.

e) **General Environment Features On and In the Site Vicinity**

1. **Natural Environment**

The majority of the site is comprised of lands dedicated to agricultural production.

2. **Listed Species**

Minimal impacts to federal- or state-listed terrestrial plants and animals are expected in association with construction at the site, due to the existing developed nature of the site and lack of suitable onsite habitat for listed species.

3. **Natural Resources of Regional Significance Status**

The construction and operation of a power generating facility at this location is not expected to have any adverse impacts on parks, recreation areas, or environmentally sensitive lands.

4. **Other Significant Features**

FPL is not aware of any other significant features of the site.

f) **Design Features and Mitigation Options**

Options include construction of PV or CC technologies. Mitigation for unavoidable impacts may occur through a combination of on- and off-site mitigation.

g) **Local Government Future Land Use Designations**

Local government future land use designation for the site is predominantly unimproved pasture. A land use map of the site and adjacent areas is also found at the end of this chapter.

h) **Site Selection Criteria Process**

The Northeast Okeechobee County site has been selected as a Preferred Site due to consideration of various factors including system load, transmission interconnection, and economics. Environmental issues were not a deciding factor since this site does not exhibit significant environmental sensitivity.

i) **Water Resources**

Groundwater and/or surface water resources are anticipated to supply water to the Northeast Okeechobee County site.

j) **Geological Features of Site and Adjacent Areas**

The hydrostratigraphy of the Northeast Okeechobee County site is similar to that of most of South Florida. In general, the groundwater system underlying Okeechobee County consists of the Surficial Aquifer System (SAS), the Intermediate Confining Unit (ICU), and the Floridan Aquifer System (FAS). The SAS consists of approximately 100 to 250 feet of undifferentiated deposits of sand, shell, clay and silt. The ICU consists of approximately 200 feet of carbonate rocks interbedded with sandy and silty clay. The multiple layers of the FAS extend thousands of feet below the ICU.

k) **Projected Water Quantities for Various Uses**

Potable water demand is expected to average .001 mgd. The estimated quantity of water required for processing at a CC unit is approximately 0.24 million gallons per day (mgd) for uses such as process water and service water. Approximately 7.5 mgd of cooling water would be used in cooling towers for a CC unit. Minimal amounts of water would be required for a PV facility.

l) Water Supply Sources by Type

Potential water supply sources are groundwater and surface water. Additional evaluations are necessary to determine which source(s) may be used.

m) Water Conservation Strategies Under Consideration

CC technology withdraws less water by design than traditional steam generation units. PV facilities have minimal water demands. Specific water conservation strategies will be evaluated and selected during the detailed design phase of any development project.

n) Water Discharges and Pollution Control

A CC plant is anticipated to utilize a closed cycle cooling (towers) system for heat dissipation. The heat recovery steam generator blowdown will be reused to the maximum extent practicable or mixed with the cooling water flow before discharge. Reverse osmosis (R/O) reject will be mixed with the plant's cooling water flow prior to discharge. Wastewater disposal is anticipated via discharge to an Underground Injection Control well system. Stormwater runoff would be collected and routed to stormwater ponds. The facility will employ Best Management Practices (BMP) and Spill Prevention, Control, and Countermeasure (SPCC) plans to prevent and control the inadvertent release of pollutants.

o) Fuel Delivery, Storage, Waste Disposal, and Pollution Control

Natural gas for a new CC unit will be transported to the site via a new natural gas pipeline lateral. New gas compressors to raise the gas pressure of the pipeline to the appropriate level for the new unit may be necessary. Back-up fuel supplies of ultra-low sulfur light fuel oil will be received by truck or pipeline and stored in an above-ground storage tank to ensure reliability of operations.

p) Air Emissions and Control Systems

The use of natural gas, ultra-low sulfur light fuel oil, and combustion controls would minimize regulated air emissions from a CC unit and ensure compliance with applicable emission limiting standards. Using these clean fuels minimizes emissions of SO₂, PM, and other fuel-bound contaminants. Combustion controls similarly minimize the formation of NO_x and the combustor design will limit the formation of CO and VOCs. When firing natural gas, NO_x emissions will be controlled using dry-low NO_x combustion technology and selective catalytic reduction (SCR). Water injection and SCR will be used to reduce NO_x emissions during operations when

using ultra- low sulfur light fuel oil as backup fuel. CC facility emissions of GHGs from combustion of natural gas achieve an emission rate substantially lower than the EPA proposed new source performance standards for GHGs. These design alternatives are equivalent to the Best Available Control Technology for air emissions, and minimize such emissions while balancing economic, environmental, and energy impacts. Taken together, the design of a CC unit would incorporate features that will make it among the most efficient and cleanest power plants in the State of Florida. PV generation does not produce air emissions.

q) Noise Emissions and Control Systems

Noise anticipated to be caused by unit construction at the site is expected to be minimal.

r) Status of Applications

FPL has not filed any applications associated with the Northeast Okeechobee County site.

Preferred Site # 7: Palatka Site, Putnam County

FPL is currently evaluating the former FPL Palatka Plant site, which was dismantled in the 1990s, for future natural gas-fired generation. This 170 acre site is located on the west side of Highway 100 opposite the FPL Putnam Plant in East Palatka. The Palatka site has been listed as a Potential Site in previous FPL Site Plans as a possibility for future natural gas-fired CC generation. FPL currently views the Palatka site as one of the most likely sites to be used for large-scale generation additions at some future date after the last of the three modernization projects are completed in 2016.

a) U.S. Geological Survey (USGS) Map

A USGS map of the Palatka site is found at the end of this chapter.

b) Proposed Facilities Layout

A map of the property owned by FPL is found at the end of this chapter.

c) Map of Site and Adjacent Areas

An overview map of the site and adjacent areas is also found at the end of this chapter.

d) Existing Land Uses of Site and Adjacent Areas

The Palatka site is designated as Industrial land use. Adjacent land uses include power generation and associated facilities (the existing FPL Putnam Plant) as well as Mixed Wetland Hardwoods, Residential and Hardwood-Coniferous Mixed.

e) General Environment Features On and In the Site Vicinity

1. Natural Environment

The majority of site has been previously impacted by past power plant operations. No significant environmental features have been identified at this time.

2. Listed Species

Minimal impacts to federal- or state-listed terrestrial plants and animals are expected in association with construction at the site, due to the existing developed nature of the site and lack of suitable onsite habitat for listed species.

3. Natural Resources of Regional Significance Status

The construction and operation of a power generating facility at this location is not expected to have any adverse impacts on parks, recreation areas, or environmentally sensitive lands.

4. Other Significant Features

FPL is not aware of any other significant features of the site.

f) Design Features and Mitigation Options

Options include construction of CC technologies. Mitigation for unavoidable impacts may occur through a combination of on- and off-site mitigation.

g) Local Government Future Land Use Designations

Local government future land use designation for the site is Industrial. A land use map of the site and adjacent areas is also found at the end of this chapter.

h) Site Selection Criteria Process

The Palatka site has been selected as a Preferred Site due to consideration of various factors including system load, transmission interconnection, and economics.

i) Water Resources

The St John's River, ground water, and/or regional water supply initiatives are potential water sources.

j) Geological Features of Site and Adjacent Areas

The hydrostratigraphy of the Palatka site is similar to that of most of North Florida. In general, the groundwater system underlying Palatka consists of the Surficial Aquifer System (SAS), and the Floridan Aquifer System (FAS).

k) Projected Water Quantities for Various Uses

Potable water demand is expected to average .001 mgd. The estimated quantity of water required at a CC unit is approximately 0.24 million gallons per day (mgd) for uses such as process water and service water. Approximately 7.5 mgd of cooling water would be used in cooling towers for a CC unit.

l) Water Supply Sources by Type

Potential water supply sources are surface and ground water. Additional evaluations are necessary to determine which source(s) may be used.

m) Water Conservation Strategies Under Consideration

CC and cooling tower technologies withdraw less water by design than traditional steam generation units. Specific water conservation strategies will be evaluated and selected during the detailed design phase of the project development.

n) Water Discharges and Pollution Control

A CC plant is anticipated to utilize a closed cycle cooling (towers) system for heat dissipation. The heat recovery steam generator blowdown will be reused to the maximum extent practicable or mixed with the cooling water flow before discharge. Reverse osmosis (R/O) reject will be mixed with the plant's cooling water flow prior to discharge. Wastewater disposal is anticipated via discharge to surface and/or ground water as with the existing Putnam Plant. Stormwater runoff would be collected and routed to stormwater ponds. The facility will employ Best Management Practices (BMP) and Spill Prevention, Control, and Countermeasure (SPCC) plans to prevent and control the inadvertent release of pollutants.

o) Fuel Delivery, Storage, Waste Disposal, and Pollution Control

Natural gas for a new CC unit will be transported to the site via a new natural gas pipeline lateral. New gas compressors to raise the gas pressure of the pipeline to the appropriate level for the new unit may be necessary. Back-up fuel supplies of ultra-low sulfur light fuel oil will be received by water-borne delivery, truck or pipeline and stored in an above-ground storage tank to ensure reliability of operations.

p) Air Emissions and Control Systems

The use of natural gas, ultra-low sulfur light fuel oil, and combustion controls would minimize regulated air emissions from a CC unit and ensure compliance with applicable emission limiting standards. Using these clean fuels minimizes emissions of SO₂, PM, and other fuel-bound contaminants. Combustion controls similarly minimize the formation of NO_x and the combustor design will limit the formation of CO and VOCs. When firing natural gas, NO_x emissions will be controlled using dry-low NO_x combustion technology and selective catalytic reduction (SCR). Water injection and SCR will be used to reduce NO_x emissions during operations when using ultra-low sulfur light fuel oil as backup fuel. CC facility emissions of GHGs from combustion of natural gas achieve an emission rate substantially lower than the EPA proposed new source performance standards for GHGs. These design alternatives are equivalent to the Best Available Control Technology for air emissions, and minimize such emissions while balancing economic, environmental, and energy impacts. Taken together, the design of a CC unit would incorporate features that will make it among the most efficient and cleanest power plants in the State of Florida.

q) Noise Emissions and Control Systems

Noise anticipated to be caused by unit construction at the site is expected to be minimal.

r) Status of Applications

FPL has not submitted any applications associated with the Palatka site.

IV.F.2 Potential Sites for Generating Options

Five (5) sites are currently identified as Potential Sites for future generation additions to meet FPL's projected capacity and energy needs.⁸ These sites have been identified as Potential Sites due to considerations of location to FPL load centers, space, infrastructure, and/or accessibility to fuel and transmission facilities. These sites are suitable for different capacity levels and technologies, including both renewable energy and non-renewable energy technologies for various sites.

Each of these Potential Sites offer a range of considerations relative to engineering and/or costs associated with the construction and operation of feasible technologies. In addition, each Potential Site has different characteristics that will require further definition and attention. Solely for the purpose of estimating water requirements for sites more suited for non-renewable energy technologies, it was assumed that either one dual-fuel (natural gas and light oil) simple cycle CT, or a natural gas-fired CC unit, would be constructed at these Potential Sites unless otherwise noted.

A simple cycle CT would require approximately 50 gallons per minute (gpm) for both process and cooling water (assuming a cooling tower was utilized). A CC unit would require approximately up to 150 gpm for process water and up to 7.5 million gallons per day (mgd) per unit for cooling water (assuming a cooling tower is utilized). If an existing power plant site is ultimately selected for modernization (as is the case with FPL's CCEC, RBEC, and PEEC sites), the water requirements discussed above for a CC unit would be approximately correct for the modernized site. If a renewable energy generating technology is ultimately selected for one of these sites, the water requirements would be significantly less than those for simple cycle CT or CC facilities.

Permits are presently considered to be obtainable for each of these sites. No significant environmental constraints are currently known for any of these sites. The Potential Sites briefly discussed below are presented in alphabetical order. At this time, FPL considers each site to be equally viable.

⁸ As has been described in previous FPL Site Plans, FPL also considers a number of other sites as possible sites for future generation additions. These include the remainder of FPL's existing generation sites and other Greenfield sites. Greenfield sites that FPL currently does not own, or for which FPL has not currently secured the necessary rights to, are not specifically identified as Potential Sites in order to protect the economic interests of FPL and its customers.

Potential Site # 1: Babcock Ranch, Charlotte County

This site is located within the proposed Babcock Ranch Community on the north side of Tuckers Grade, approximately 10.5 miles north of the intersection of SR-80 and SR-31 and 1.1 miles east of SR-31. The project is bordered on the north by the Babcock Ranch Preserve owned by the State of Florida. This site is a possibility for an FPL PV facility. FPL has received all permits necessary to construct a 74 MW PV facility at this location.

a. **U.S. Geological Survey (USGS) Map**

A map of this site is found at the end of this chapter.

b. **Land Uses**

Existing land use on the site is the Babcock Ranch Overlay District, and it is zoned as the Babcock Ranch Overlay Zoning District. This land use and zoning allows for solar facilities.

c. **Environmental Features**

FPL anticipates mitigating for unavoidable wildlife and/or wetland impacts as needed as a result of a PV project constructed at this site.

d. **Water Quantities**

Minimal amounts of water, if any, would be required for a PV facility.

e. **Supply Sources**

Minimal water would be required for a PV facility. A small amount may be needed to occasionally clean the solar panels in the absence of sufficient rainfall. Any such water may be brought to the site by truck.

Potential Site # 2: DeSoto Solar Expansion, DeSoto County

The DeSoto site is located at 4051 Northeast Karson Street which is approximately 0.3 miles east of U.S. Highway 17 and immediately north of Bobay Road in Arcadia, Florida. The site is located in Sections 26, 27, & 35, Township 36 South, and Range 25 East. FPL owns an approximate 13,000 acre parcel in DeSoto County. FPL has designated approximately 5,177 acres for development of a PV facility.

The DeSoto site is home to a 25 MW PV facility that has been operational since 2009. Up to an additional 275 MW of PV generation could be constructed in phases on the remaining undeveloped land. FPL has initiated permitting for the additional PV facilities.

a. **U.S. Geological Survey (USGS) Map**

A map of this site is found at the end of this chapter.

b. **Land Uses**

Existing land use on the site is agricultural. The future land use is Electric Generating Facility.

c. **Environmental Features**

There are no significant environmental features on the site.

d. **Water Quantities**

Minimal amounts of water would be required for a future expansion of the existing PV facility.

e. **Supply Sources**

Minimal water would be required for an expanded PV facility. A small amount may be needed to occasionally clean the PV panels in the absence of sufficient rainfall. Potable water will be required in the administration building and maintenance building. FPL would propose to utilize existing wells onsite to accommodate water needs.

Potential Site # 3: Manatee Plant Site, Manatee County

The existing FPL Manatee Plant 9,500-acre site is located in unincorporated north-central Manatee County. The existing power generating facilities are located in all or portions of Sections 18 and 19 of Township 33S, Range 20-E. The plant site lies approximately 5 miles east of Parrish, Florida. It is approximately 5 miles east of U.S. Highway 301 and 9.5 miles east of Interstate Highway 75 (I-75). The existing plant is approximately 2.5 miles south of the Hillsborough-Manatee County line; a portion of the north property boundary of the plant site abuts the county line. State Road 62 (SR 62) is about 0.7 mile south of the plant, with the plant entrance road going north from that highway. This site is a possible location for an FPL PV facility. FPL has received the federal and state permits required to construct approximately 50 MW of PV at this location.

a. **U.S. Geological Survey (USGS) Map**

A map of the site is found at the end of this chapter.

b. **Land Uses**

Existing land use on the site is agricultural. The property is zoned Planned Development / Public Interest (PD-PI), which will allow for electrical generation.

c. **Environmental Features**

FPL anticipates mitigating for unavoidable wildlife and/or wetland impacts as needed as a result of a PV project constructed at this site.

d. **Water Quantities**

Minimal amounts of water would be required for a PV facility.

e. **Supply Sources**

Minimal water would be required for a PV facility. A small amount may be needed to occasionally clean the PV panels in the absence of sufficient rainfall. Panel cleaning water source may be existing potable water or water tank trucked to the site.

Potential Site # 4: Martin County, Martin County

FPL is currently evaluating potential sites in Martin County for a future PV facility. No specific locations have been selected at this time.

a. **U.S. Geological Survey (USGS) Map**

A USGS map of the county has been included at the end of this chapter.

b. **Land Uses**

This information is not available because a specific site has not been selected at this time.

c. **Environmental Features**

This information is not available because a specific site has not been selected at this time.

d. **Water Quantities**

Minimal amounts of water would be required for a PV facility.

e. **Supply Sources**

Minimal water would be required for a PV facility. A small amount may be needed to occasionally clean the PV panels in the absence of sufficient rainfall.

Potential Site # 5: Putnam County

FPL is currently evaluating potential sites in Putnam County for a future PV facility or natural gas power generation. Sites currently under investigation are approximately 2,800 acres. No specific locations have been selected at this time.

a. **U.S. Geological Survey (USGS) Map**

A USGS map of the county has been included at the end of this chapter.

b. **Land Uses**

This information is not available because a specific site has not been selected at this time.

c. **Environmental Features**

This information is not available because a specific site has not been selected at this time.

d. **Water Quantities**

Minimal amounts of water would be required for a PV facility. Natural gas power generation would require approximately up to 150 gallons per minute (gpm) for process water and up to 7.5 million gallons per day (mgd) per unit for cooling water (assuming a cooling tower is utilized).

e. **Supply Sources**

The St John's River, existing groundwater, and/or regional water supply initiatives are potential water sources.

(This page is left intentionally blank.)

***Environmental and Land Use Information:
Supplemental Information***

Preferred Site #1: Turkey Point Plant

(This page is left intentionally blank.)

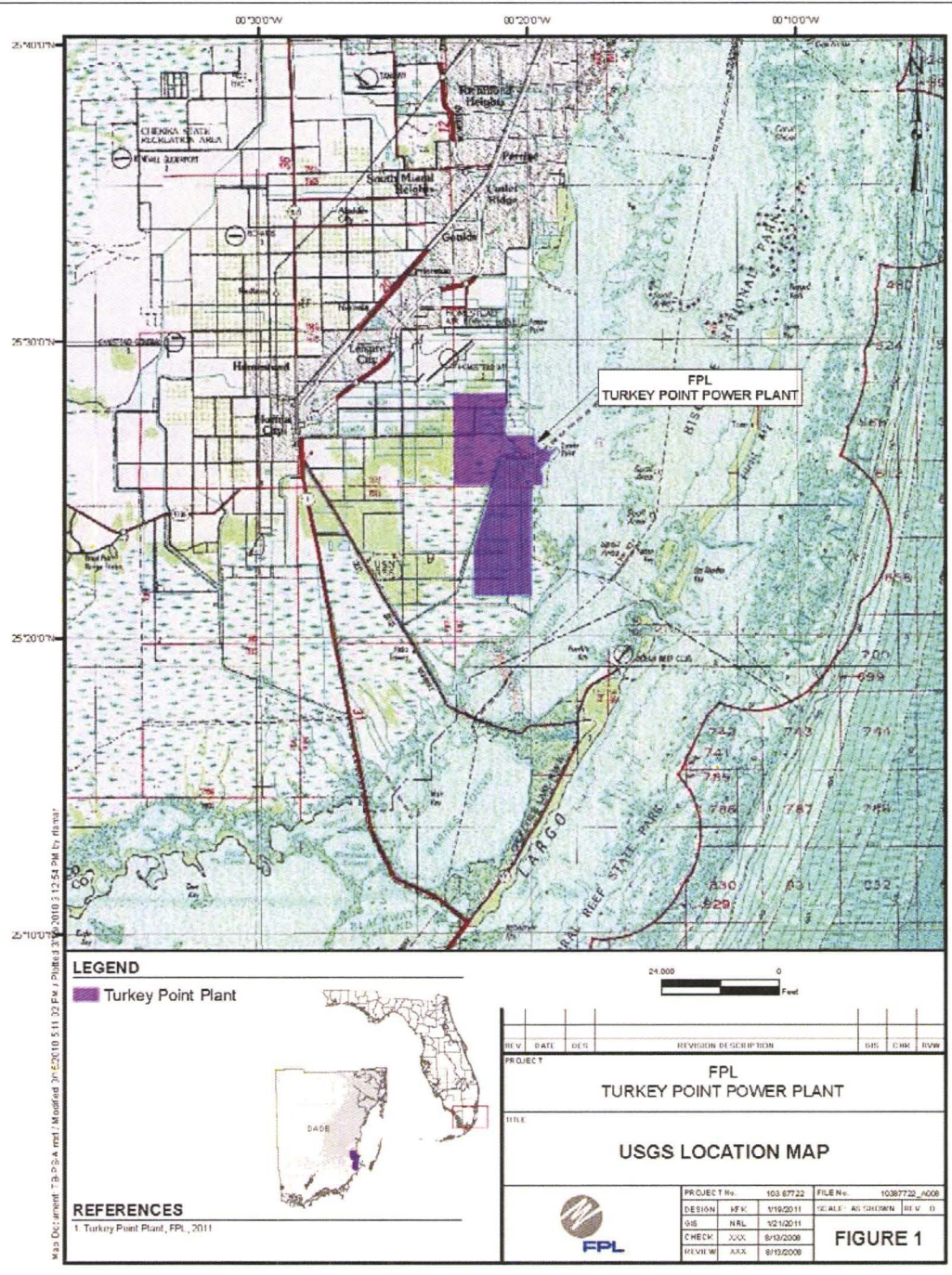

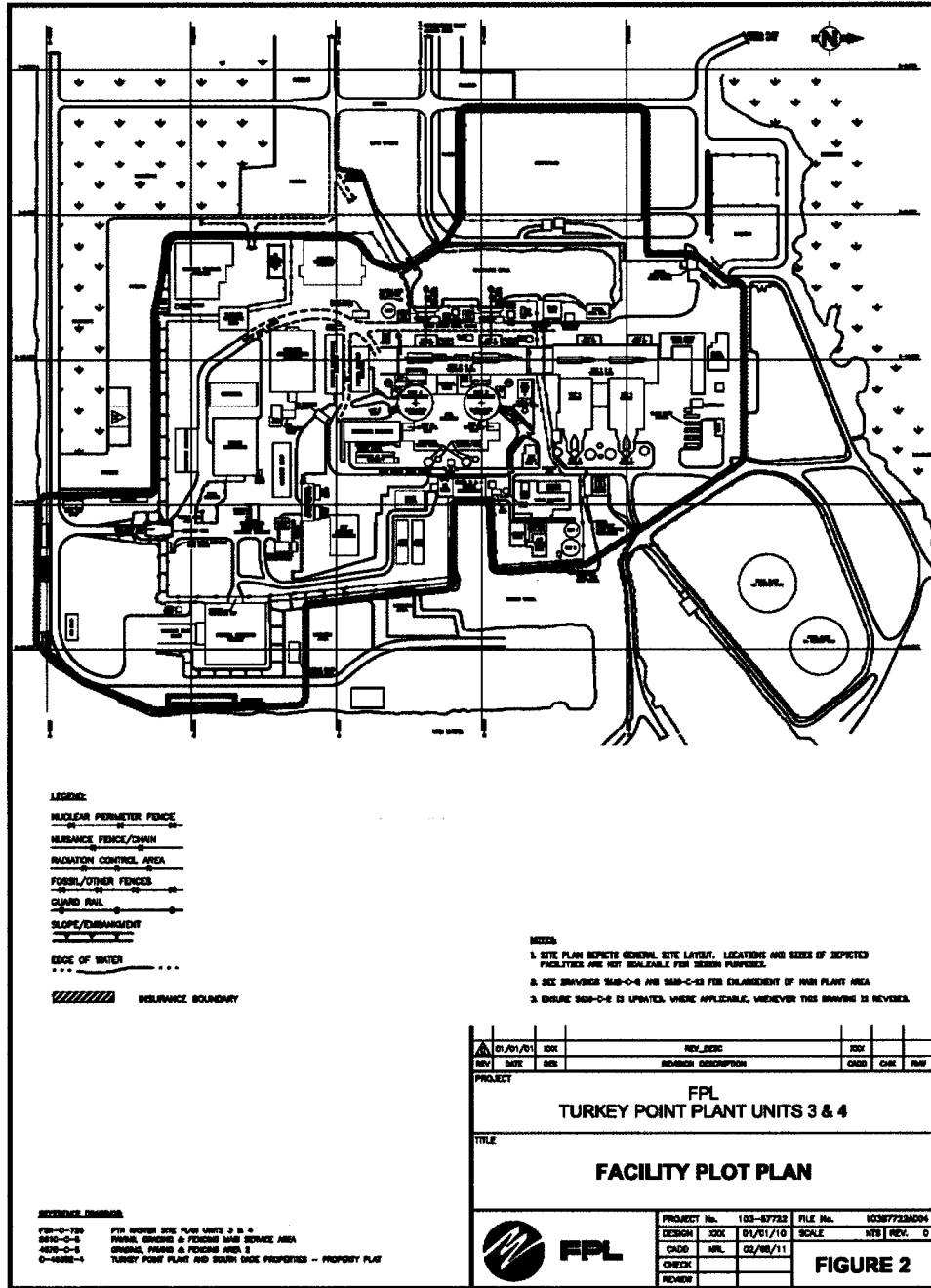



Map Document: TBP25.mxd / Modified: 9/19/2010 5:11:02 PM / Plotted: 3/19/2010 3:13:54 PM by slamar

LEGEND

001 Policy Area/Zone	002 001 - 10000	003 002 - 10000	004 003 - 10000
005 004 - 10000	006 005 - 10000	007 006 - 10000	008 007 - 10000
009 008 - 10000	010 009 - 10000	011 010 - 10000	012 011 - 10000
013 012 - 10000	014 013 - 10000	015 014 - 10000	016 015 - 10000
017 016 - 10000	018 017 - 10000	019 018 - 10000	020 019 - 10000
021 020 - 10000	022 021 - 10000	023 022 - 10000	024 023 - 10000
025 024 - 10000	026 025 - 10000	027 026 - 10000	028 027 - 10000
029 028 - 10000	030 029 - 10000	031 030 - 10000	032 031 - 10000
033 032 - 10000	034 033 - 10000	035 034 - 10000	036 035 - 10000
037 036 - 10000	038 037 - 10000	039 038 - 10000	040 039 - 10000
041 040 - 10000	042 041 - 10000	043 042 - 10000	044 043 - 10000
045 044 - 10000	046 045 - 10000	047 046 - 10000	048 047 - 10000
049 048 - 10000	050 049 - 10000	051 050 - 10000	052 051 - 10000
053 052 - 10000	054 053 - 10000	055 054 - 10000	056 055 - 10000
057 056 - 10000	058 057 - 10000	059 058 - 10000	060 059 - 10000
061 060 - 10000	062 061 - 10000	063 062 - 10000	064 063 - 10000
065 064 - 10000	066 065 - 10000	067 066 - 10000	068 067 - 10000
069 068 - 10000	070 069 - 10000	071 070 - 10000	072 071 - 10000
073 072 - 10000	074 073 - 10000	075 074 - 10000	076 075 - 10000
077 076 - 10000	078 077 - 10000	079 078 - 10000	080 079 - 10000
081 080 - 10000	082 081 - 10000	083 082 - 10000	084 083 - 10000
085 084 - 10000	086 085 - 10000	087 086 - 10000	088 087 - 10000
089 088 - 10000	090 089 - 10000	091 090 - 10000	092 091 - 10000
093 092 - 10000	094 093 - 10000	095 094 - 10000	096 095 - 10000
097 096 - 10000	098 097 - 10000	099 098 - 10000	100 099 - 10000
101 100 - 10000	102 101 - 10000	103 102 - 10000	104 103 - 10000
105 104 - 10000	106 105 - 10000	107 106 - 10000	108 107 - 10000
109 108 - 10000	110 109 - 10000	111 110 - 10000	112 111 - 10000
113 112 - 10000	114 113 - 10000	115 114 - 10000	116 115 - 10000
117 116 - 10000	118 117 - 10000	119 118 - 10000	120 119 - 10000
121 120 - 10000	122 121 - 10000	123 122 - 10000	124 123 - 10000
125 124 - 10000	126 125 - 10000	127 126 - 10000	128 127 - 10000
129 128 - 10000	130 129 - 10000	131 130 - 10000	132 131 - 10000
133 132 - 10000	134 133 - 10000	135 134 - 10000	136 135 - 10000
137 136 - 10000	138 137 - 10000	139 138 - 10000	140 139 - 10000
141 140 - 10000	142 141 - 10000	143 142 - 10000	144 143 - 10000
145 144 - 10000	146 145 - 10000	147 146 - 10000	148 147 - 10000
149 148 - 10000	150 149 - 10000	151 150 - 10000	152 151 - 10000
153 152 - 10000	154 153 - 10000	155 154 - 10000	156 155 - 10000
157 156 - 10000	158 157 - 10000	159 158 - 10000	160 159 - 10000
161 160 - 10000	162 161 - 10000	163 162 - 10000	164 163 - 10000
165 164 - 10000	166 165 - 10000	167 166 - 10000	168 167 - 10000
169 168 - 10000	170 169 - 10000	171 170 - 10000	172 171 - 10000
173 172 - 10000	174 173 - 10000	175 174 - 10000	176 175 - 10000
177 176 - 10000	178 177 - 10000	179 178 - 10000	180 179 - 10000
181 180 - 10000	182 181 - 10000	183 182 - 10000	184 183 - 10000
185 184 - 10000	186 185 - 10000	187 186 - 10000	188 187 - 10000
189 188 - 10000	190 189 - 10000	191 190 - 10000	192 191 - 10000
193 192 - 10000	194 193 - 10000	195 194 - 10000	196 195 - 10000
197 196 - 10000	198 197 - 10000	199 198 - 10000	200 199 - 10000

REFERENCES

- 1. Turkey Point Plant, FPL, 2011
- 2. Land Use, SFWMD FLUCCS, 2004-05



REV	DATE	DES	REVISION DESCRIPTION	GIS	CHK	ROW

PROJECT
FPL
TURKEY POINT POWER PLANT

TITLE
LAND USE / LAND COVER



PROJECT No	103-87722	FILE No	10387722_A013
DESIGN	KFK	1/19/2011	SCALE AS SHOWN
DESIGNED BY	NRL	2/6/2011	REV 0
CHECKED BY	JXX	8/13/2008	
REVIEWED BY	JAX	8/13/2008	

FIGURE 3

(This page is left intentionally blank.)

***Environmental and Land Use Information:
Supplemental Information***

Preferred Site #2: Cape Canaveral Plant

(This page is left intentionally blank.)

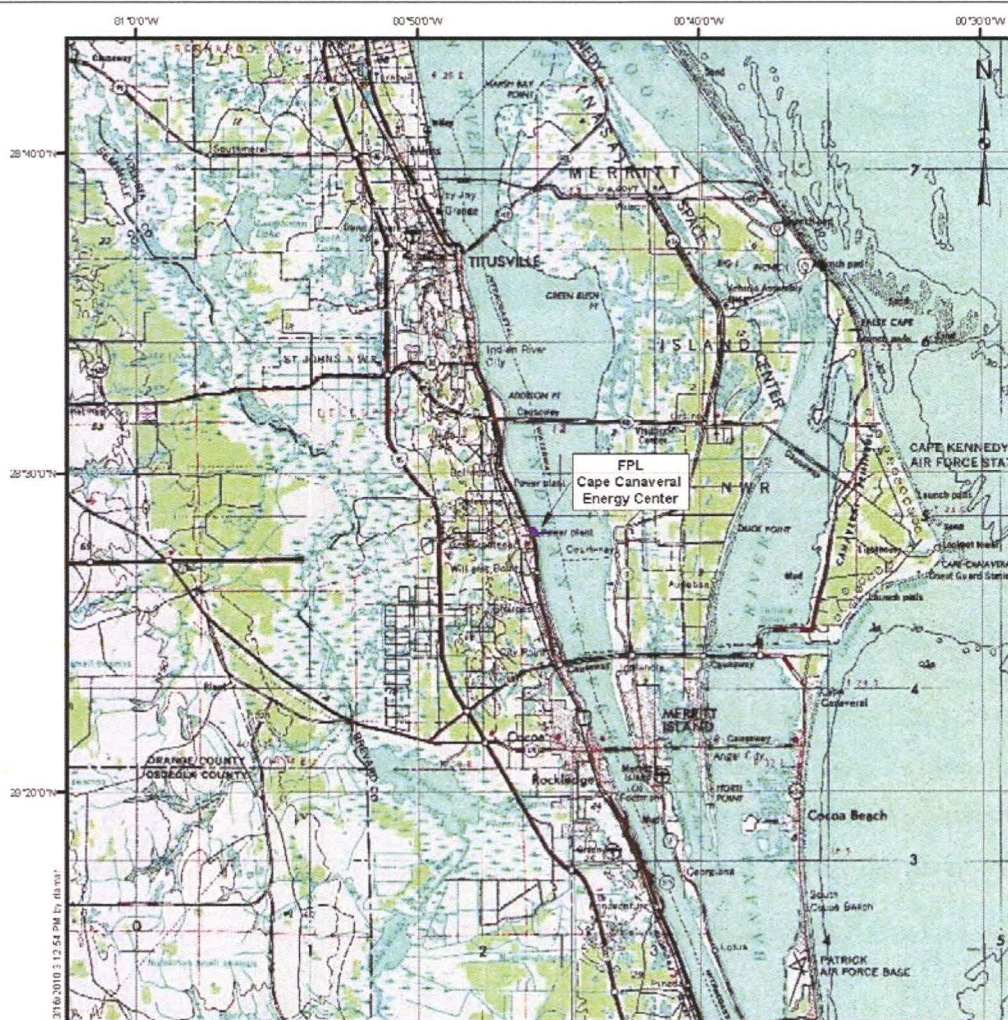

LEGEND

■ Cape Canaveral Energy Center

REFERENCES

1. Cape Canaveral Energy Center, FPL, 2011

24,000 0 Feet

REV	DATE	DES	REVISION DESCRIPTION	DES	CHK	APP
PROJECT						
FPL CAPE CANAVERAL ENERGY CENTER						
TITLE						
USGS LOCATION MAP						
PROJECT No.		103.87722	FILE No.		10387722_4000	
DESIGN	HPK	5/18/2011	SCALE:	AS SHOWN	REV	0
GIS	NRL	5/21/2011				
CHECK	JCC	8/13/2008	FIGURE 1			
REVIEW	AKA	8/13/2008				

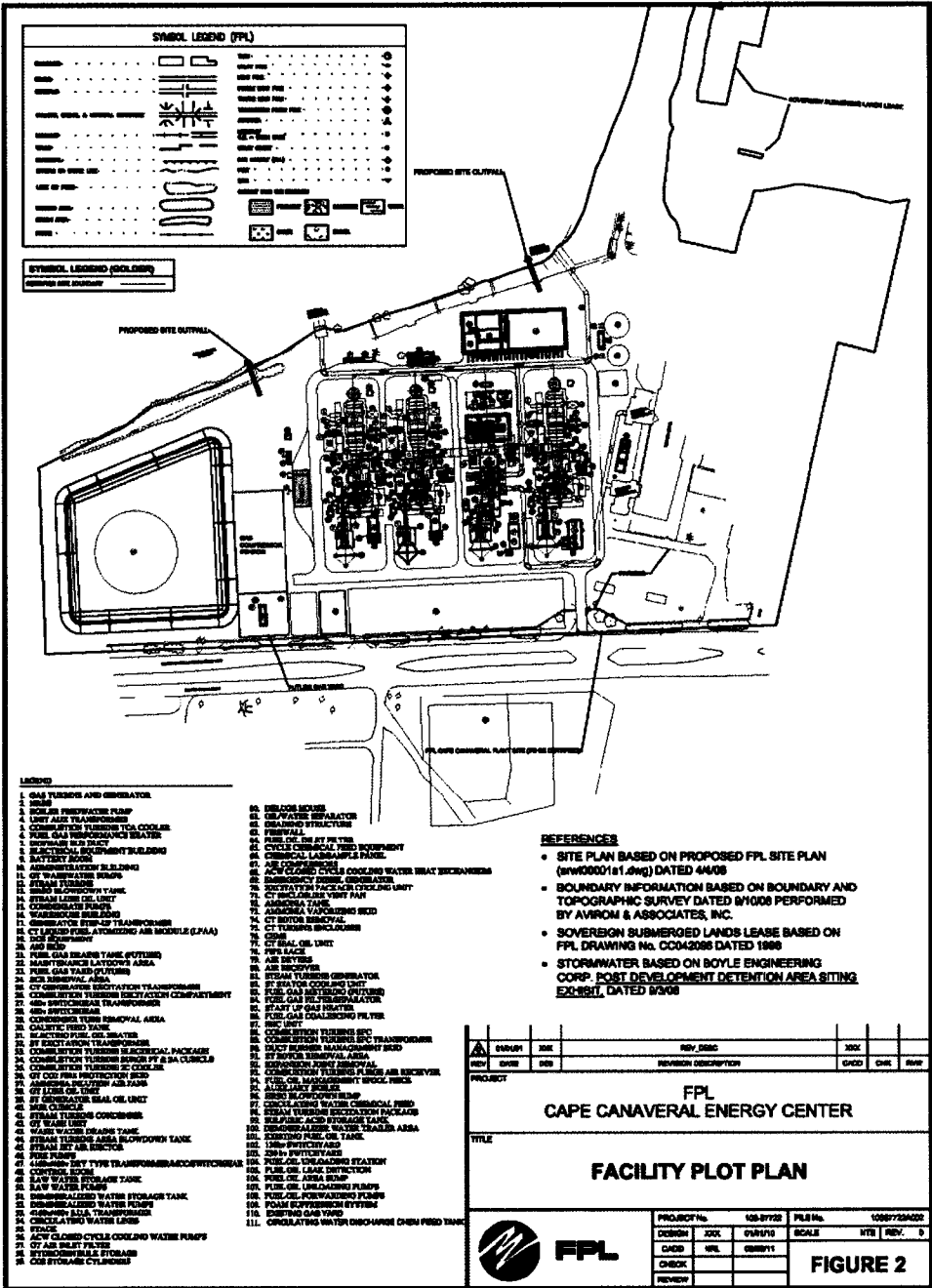

SYMBOL LEGEND (FPL)

Symbol	Description
[Symbol]	Gas Turbine
[Symbol]	Generator
[Symbol]	Combustion Turbine
[Symbol]	Water Treatment
[Symbol]	Piping
[Symbol]	Storage Tank
[Symbol]	Building
[Symbol]	Valve
[Symbol]	Control Panel
[Symbol]	Electrical Panel
[Symbol]	Structural Steel
[Symbol]	Site Boundary
[Symbol]	Proposed Site Outline

SYMBOL LEGEND (SLOTTING)

Symbol	Description
[Symbol]	Slotting
[Symbol]	Slotting
[Symbol]	Slotting

- LEGEND**
- 1. GAS TURBINES AND GENERATOR
 - 2. SEAWATER PUMP
 - 3. LOW VOLT TRANSFORMER
 - 4. COMBUSTION TURBINE TO COOLER
 - 5. FUEL GAS CONDENSATE STORAGE
 - 6. SUPPLY AIR BUILT
 - 7. ELECTRICAL EQUIPMENT BUILDING
 - 8. BATTERY ROOM
 - 9. ADMINISTRATION BUILDING
 - 10. ADMINISTRATION BUILDING
 - 11. CW WATER TREATMENT
 - 12. STRAIN TRENCH
 - 13. SEAWATER BLOWDOWN TANK
 - 14. STRAIN LINE OR UNIT
 - 15. CONDENSATE PUMPS
 - 16. WASTEWATER REUSE SYSTEM
 - 17. GENERATOR STEP-UP TRANSFORMER
 - 18. CYCLOPS FUEL VAPORIZING AIR MIDDLE (FVA)
 - 19. AIR BUILT
 - 20. FUEL GAS READING TANK (FOTR)
 - 21. SEAWATER LACTIC ACID AREA
 - 22. FUEL GAS TREATMENT
 - 23. FUEL GAS TREATMENT
 - 24. FUEL GAS TREATMENT
 - 25. CW CONDENSATE RECYCLATION TRANSFORMER
 - 26. COMBUSTION TURBINE RECYCLATION COMPARTMENT
 - 27. 400V SWITCHGEAR
 - 28. 400V SWITCHGEAR
 - 29. CONDENSATE TURBINE REMOVAL AREA
 - 30. CALTIC FUEL TANK
 - 31. SEAWATER PUMP
 - 32. SEAWATER PUMP
 - 33. SEAWATER PUMP
 - 34. COMBUSTION TURBINE REMOVAL AREA
 - 35. COMBUSTION TURBINE REMOVAL AREA
 - 36. COMBUSTION TURBINE REMOVAL AREA
 - 37. COMBUSTION TURBINE REMOVAL AREA
 - 38. COMBUSTION TURBINE REMOVAL AREA
 - 39. COMBUSTION TURBINE REMOVAL AREA
 - 40. COMBUSTION TURBINE REMOVAL AREA
 - 41. COMBUSTION TURBINE REMOVAL AREA
 - 42. COMBUSTION TURBINE REMOVAL AREA
 - 43. COMBUSTION TURBINE REMOVAL AREA
 - 44. COMBUSTION TURBINE REMOVAL AREA
 - 45. COMBUSTION TURBINE REMOVAL AREA
 - 46. COMBUSTION TURBINE REMOVAL AREA
 - 47. COMBUSTION TURBINE REMOVAL AREA
 - 48. COMBUSTION TURBINE REMOVAL AREA
 - 49. COMBUSTION TURBINE REMOVAL AREA
 - 50. COMBUSTION TURBINE REMOVAL AREA
 - 51. COMBUSTION TURBINE REMOVAL AREA
 - 52. COMBUSTION TURBINE REMOVAL AREA
 - 53. COMBUSTION TURBINE REMOVAL AREA
 - 54. COMBUSTION TURBINE REMOVAL AREA
 - 55. COMBUSTION TURBINE REMOVAL AREA
 - 56. COMBUSTION TURBINE REMOVAL AREA
 - 57. COMBUSTION TURBINE REMOVAL AREA
 - 58. COMBUSTION TURBINE REMOVAL AREA
 - 59. COMBUSTION TURBINE REMOVAL AREA
 - 60. COMBUSTION TURBINE REMOVAL AREA
 - 61. COMBUSTION TURBINE REMOVAL AREA
 - 62. COMBUSTION TURBINE REMOVAL AREA
 - 63. COMBUSTION TURBINE REMOVAL AREA
 - 64. COMBUSTION TURBINE REMOVAL AREA
 - 65. COMBUSTION TURBINE REMOVAL AREA
 - 66. COMBUSTION TURBINE REMOVAL AREA
 - 67. COMBUSTION TURBINE REMOVAL AREA
 - 68. COMBUSTION TURBINE REMOVAL AREA
 - 69. COMBUSTION TURBINE REMOVAL AREA
 - 70. COMBUSTION TURBINE REMOVAL AREA
 - 71. COMBUSTION TURBINE REMOVAL AREA
 - 72. COMBUSTION TURBINE REMOVAL AREA
 - 73. COMBUSTION TURBINE REMOVAL AREA
 - 74. COMBUSTION TURBINE REMOVAL AREA
 - 75. COMBUSTION TURBINE REMOVAL AREA
 - 76. COMBUSTION TURBINE REMOVAL AREA
 - 77. COMBUSTION TURBINE REMOVAL AREA
 - 78. COMBUSTION TURBINE REMOVAL AREA
 - 79. COMBUSTION TURBINE REMOVAL AREA
 - 80. COMBUSTION TURBINE REMOVAL AREA
 - 81. COMBUSTION TURBINE REMOVAL AREA
 - 82. COMBUSTION TURBINE REMOVAL AREA
 - 83. COMBUSTION TURBINE REMOVAL AREA
 - 84. COMBUSTION TURBINE REMOVAL AREA
 - 85. COMBUSTION TURBINE REMOVAL AREA
 - 86. COMBUSTION TURBINE REMOVAL AREA
 - 87. COMBUSTION TURBINE REMOVAL AREA
 - 88. COMBUSTION TURBINE REMOVAL AREA
 - 89. COMBUSTION TURBINE REMOVAL AREA
 - 90. COMBUSTION TURBINE REMOVAL AREA
 - 91. COMBUSTION TURBINE REMOVAL AREA
 - 92. COMBUSTION TURBINE REMOVAL AREA
 - 93. COMBUSTION TURBINE REMOVAL AREA
 - 94. COMBUSTION TURBINE REMOVAL AREA
 - 95. COMBUSTION TURBINE REMOVAL AREA
 - 96. COMBUSTION TURBINE REMOVAL AREA
 - 97. COMBUSTION TURBINE REMOVAL AREA
 - 98. COMBUSTION TURBINE REMOVAL AREA
 - 99. COMBUSTION TURBINE REMOVAL AREA
 - 100. COMBUSTION TURBINE REMOVAL AREA
 - 101. COMBUSTION TURBINE REMOVAL AREA
 - 102. COMBUSTION TURBINE REMOVAL AREA
 - 103. COMBUSTION TURBINE REMOVAL AREA
 - 104. COMBUSTION TURBINE REMOVAL AREA
 - 105. COMBUSTION TURBINE REMOVAL AREA
 - 106. COMBUSTION TURBINE REMOVAL AREA
 - 107. COMBUSTION TURBINE REMOVAL AREA
 - 108. COMBUSTION TURBINE REMOVAL AREA
 - 109. COMBUSTION TURBINE REMOVAL AREA
 - 110. COMBUSTION TURBINE REMOVAL AREA
 - 111. COMBUSTION TURBINE REMOVAL AREA

- REFERENCES**
- SITE PLAN BASED ON PROPOSED FPL SITE PLAN (REVISED 1st Aug) DATED 4/10/08
 - BOUNDARY INFORMATION BASED ON BOUNDARY AND TOPOGRAPHIC SURVEY DATED 8/10/08 PERFORMED BY AVIRON & ASSOCIATES, INC.
 - SOVEREIGN SUBMERGED LANDS LEASE BASED ON FPL DRAWING NO. CCA0208 DATED 1988
 - STORMWATER BASED ON BOYLE ENGINEERING CORP. POST DEVELOPMENT DETENTION AREA SITING EXHIBIT, DATED 8/3/08

REV	DATE	BY	DESC	CHK	APP

PROJECT: **FPL CAPE CANAVERAL ENERGY CENTER**

TITLE: **FACILITY PLOT PLAN**

PROJECT No.	108-87720	PLN No.	1080728A001
DESIGN	JOC	DATE	07/01/10
SCALE	MTS	REV.	0
CHECK			
REVIEW			



FIGURE 2



Map Document: TBPFS-A.mxd / Modified: 3/19/2010 5:11:02 PM / Plotted: 3/19/2010 3:12:54 PM by: rhamar

LEGEND		
110 - Residential, Low Density	170 - Institutional	430 - Wetland Forested Mixed
111 - Single-Family Detached	184 - Marine and Fish Cange	441 - Freshwater Marshes
112 - Single-Family Attached	185 - Parks and Zoos	442 - Wet Pannes
113 - Low-Density Under Construction	310 - Herbaceous (Dry Prairie)	644 - Emergent Aquatic Vegetation
114 - Residential, Medium Density	320 - Decid and Broadleaf	645 - Freshwater Swamps
115 - High-Density Residential	330 - Mixed Woodland	720 - Sand Other Than Beaches
116 - Medium-Density Under Construction	411 - Pine Forests	741 - Rural land in transition
117 - Residential, High Density	412 - Longleaf Pine/Koak Oak	750 - Wetland Forested Mixed
140 - Commercial and Services	420 - Upland Hardwood Forest	812 - Railroads
153 - Mineral Processing	434 - Hardwood Coniferous Mixed	814 - Roads and Highways
155 - Other Light Industrial	500 - Lakes	821 - Electric Power Facilities
162 - Sand and Gravel Pits	530 - Reservoirs	822 - Electric Power Transmission Lines
166 - Holding Ponds	540 - Barc and Estuaries	824 - Sewage Treatment
	617 - Mixed Wetland Hardwoods	

REFERENCES	
1	Cape Canaveral Energy Center, FPL, 2011
2	Land Use, SUPWMD, 2004

REV	DATE	DES	REVISION DESCRIPTION	GIS	CHK	REV
PROJECT: FPL CAPE CANAVERAL ENERGY CENTER						
TITLE: LAND USE / LAND COVER						
		PROJECT No	103-87722	FILE No	S987722_A014	
DESIGN	LJK	1/19/2011	SCALE	AS SHOWN	REV	0
GIS	NRL	1/26/2011	FIGURE 3			
CHECK	JJK	8/13/2008				
REVIEW	JJK	8/13/2008				

(This page is left intentionally blank.)

***Environmental and Land Use Information:
Supplemental Information
Preferred Site #3: Riviera Beach Plant***

(This page is left intentionally blank.)

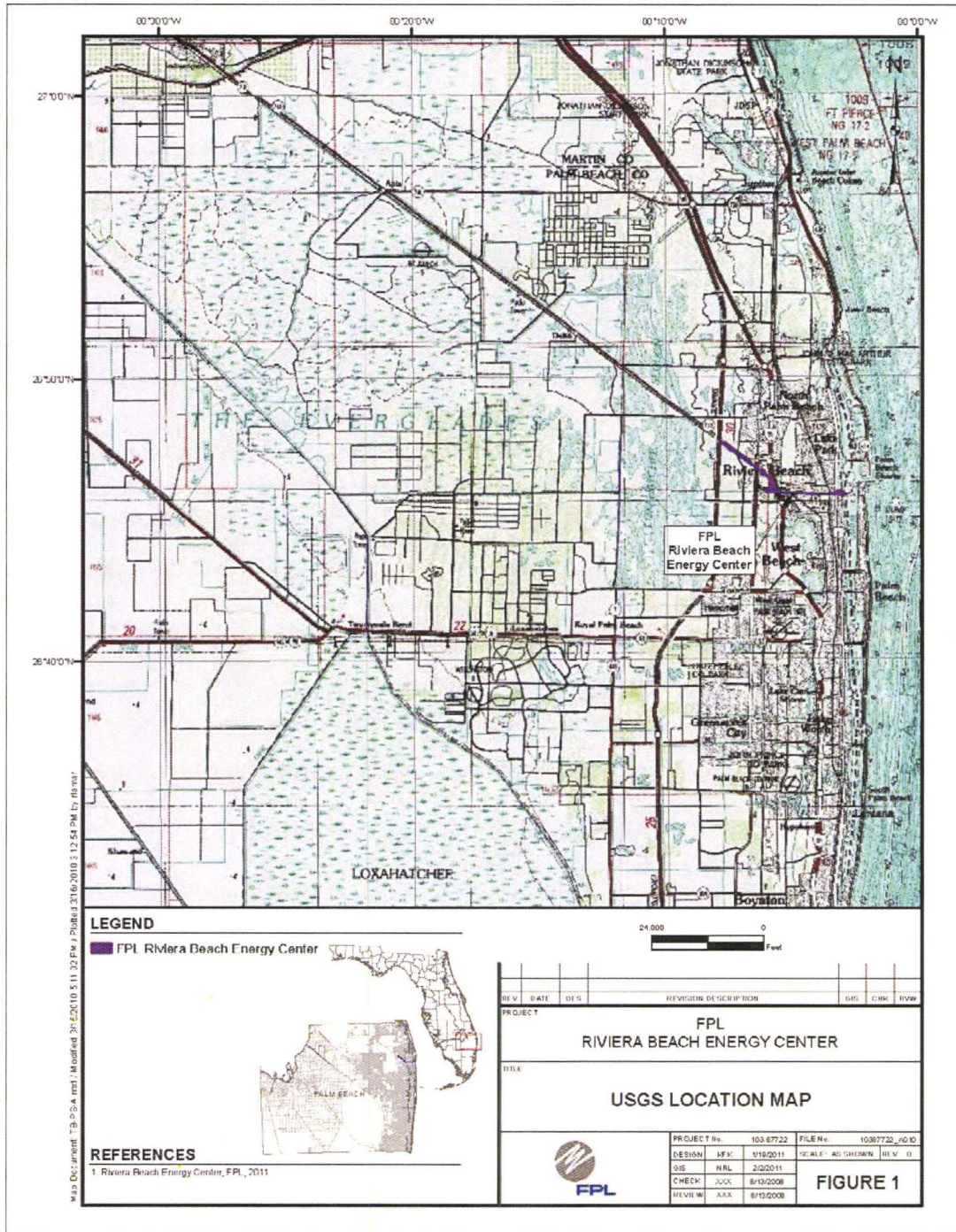

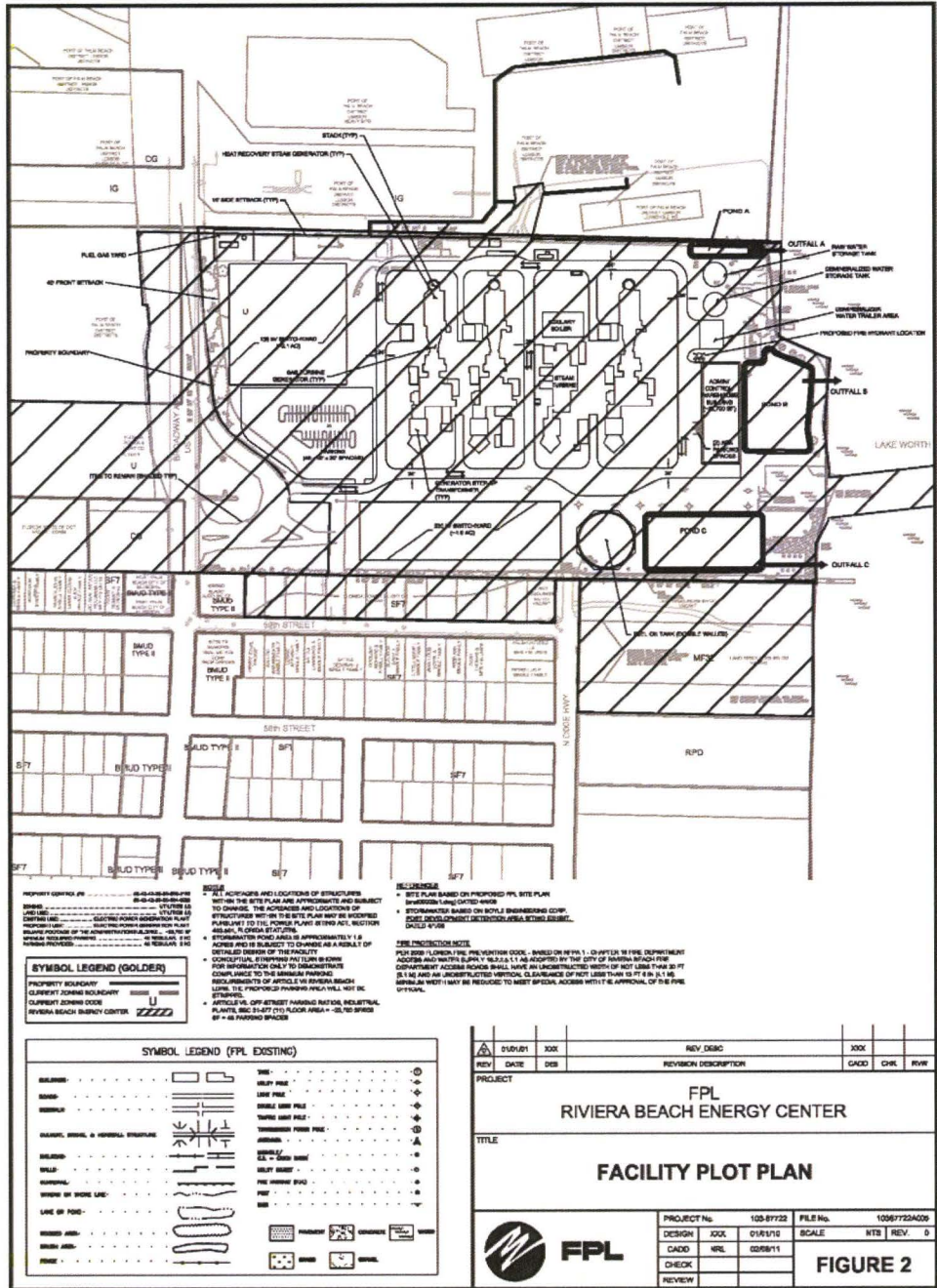



(This page is left intentionally blank.)

***Environmental and Land Use Information:
Supplemental Information
Preferred Site #4: Port Everglades Plant***

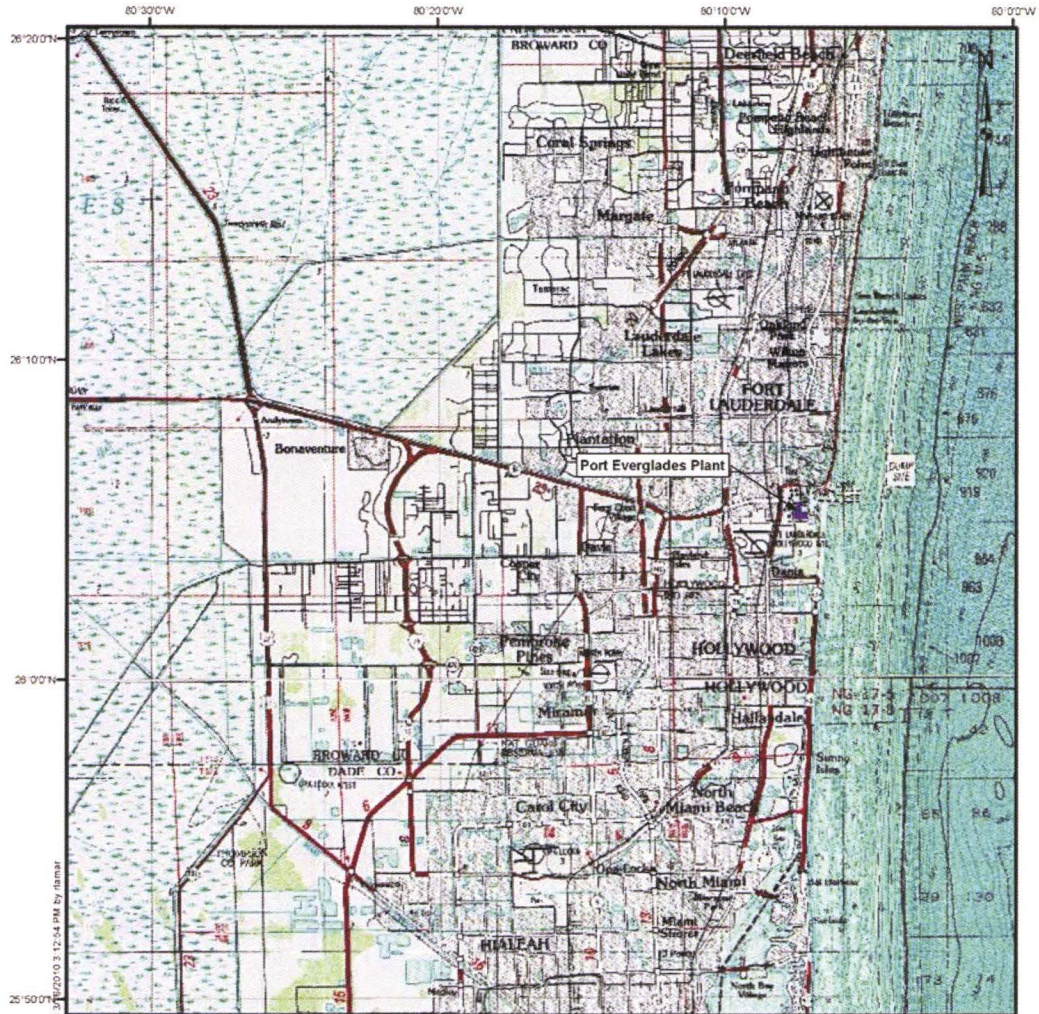
(This page is left intentionally blank.)



LEGEND

 Port Everglades Plant

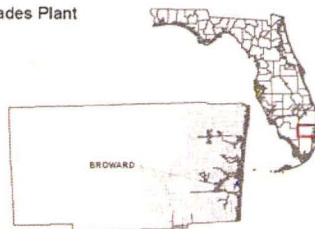

REFERENCES

1 Port Everglades Plant, FPL, 2011



REV	DATE	DES	REVISION DESCRIPTION	DES	CHK	REV
PROJECT						
FPL						
PORT EVERGLADES PLANT						
TITLE						
USGS LOCATION MAP						
PROJECT No		103-87722	FILE No		10387722_A041	
DESIGN	KPK	1/18/2011	SCALE	AS SHOWN	REV 0	
DES	NRL	3/8/2011	FIGURE 1			
CHECK	XXX	8/13/2008				
REVIEW	XXX	8/13/2008				



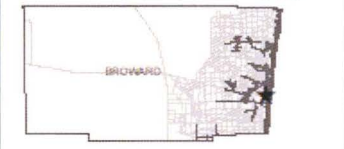
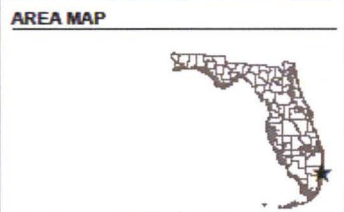
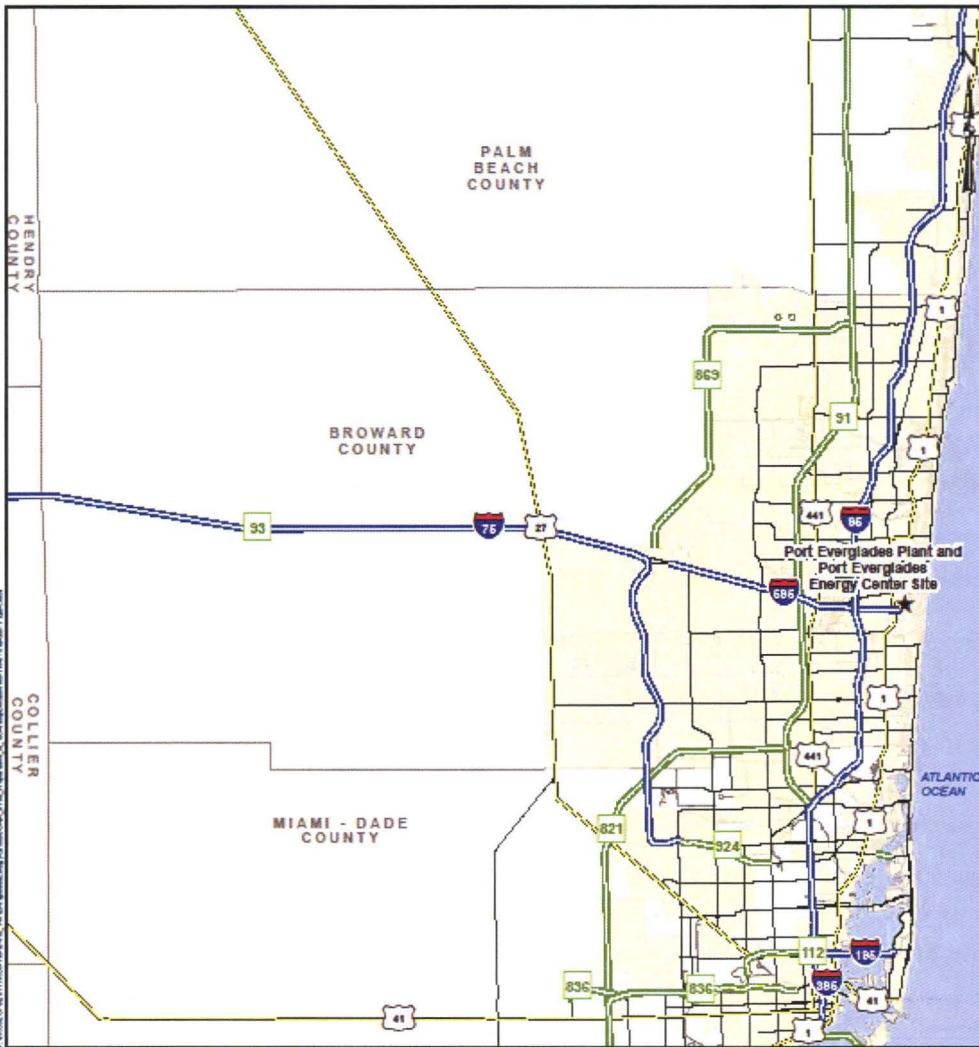

LEGEND

- ★ Port Everglades Plant and Port Everglades Energy Center Site

REFERENCES

1. Port Everglades Plant and Port Everglades Energy Center Site Location, FPL 2011
2. Municipalities, Broward County Florida, 2011, Palm Beach County Florida, 2010, and Miami Dade County Florida, 2009
3. Roads, Florida Department of Transportation, 2011



REV	DATE	BY	DESCRIPTION	APP	CHK	APP

FPL
PORT EVERGLADES ENERGY CENTER

THE
GENERAL LOCATION OF THE
FPL PORT EVERGLADES PLANT AND
PORT EVERGLADES ENERGY CENTER

	PROJECT NO.	042011	FPL No. 042011_000
	DRAWN	WCL	12/09/11
	CHK	WCL	01/04/12
	DATE	01/04/12	SCALE
REVISED	WCL	01/04/12	FIGURE 2

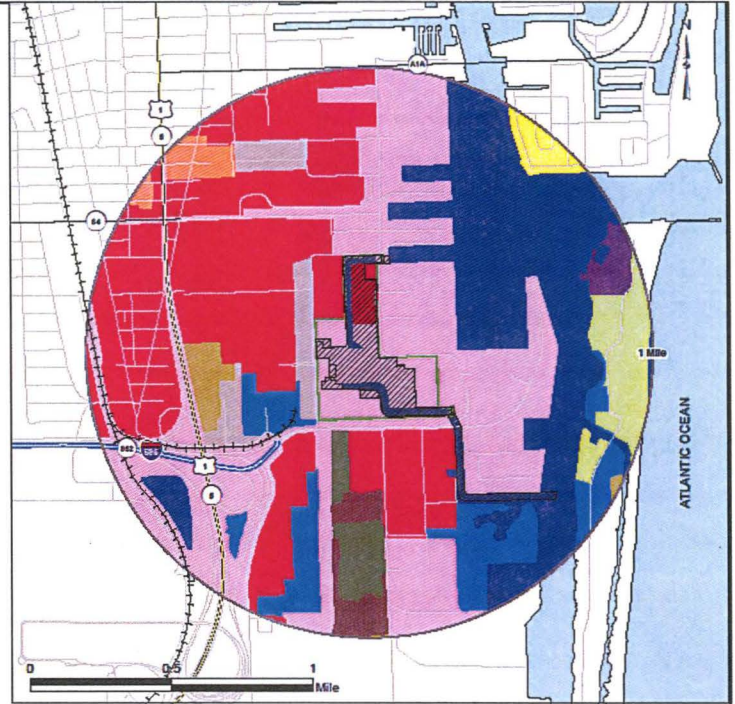
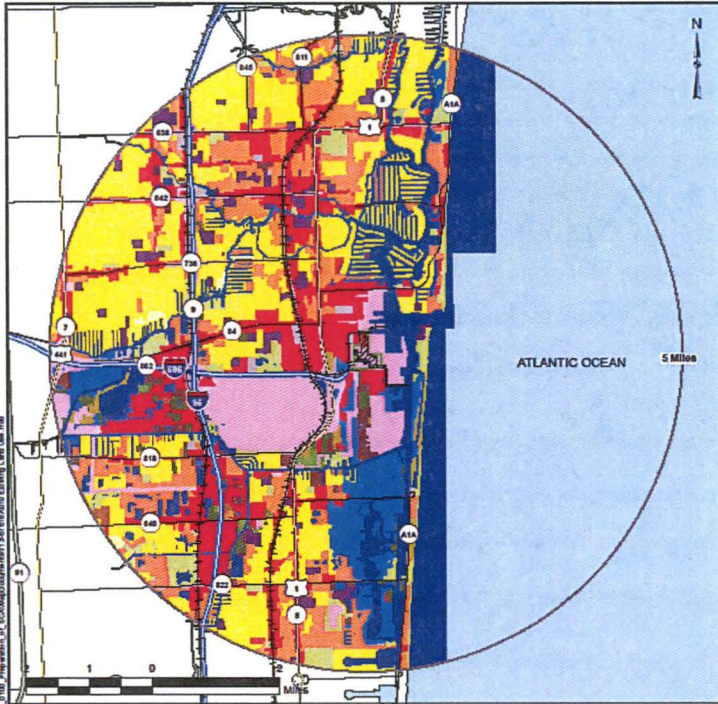

LEGEND

- Port Everglades Plant Property
- Port Everglades Energy Center Site
- Existing Land Use (SFWMD based on FLUCCS Level II)**
- Low Density Urban
- Medium Density Urban
- High Density Urban
- Commercial
- Industrial
- Mining
- Institutional
- Recreational
- Open Land
- Agriculture
- Rangeland
- Upland Forests
- Water
- Wetlands
- Barren Land
- Transportation, Communication, Utilities

REFERENCES

1. Port Everglades Plant Property, Port Everglades Energy Center Site, FPL, 2011
2. Existing Land Use, South Florida Water Management District Florida Land Use, Cover and Form Classification System Level II, 2008

REV.	DATE	DES.	REVISION DESCRIPTION	DES.	CHK.	APP.
PROJECT FPL PORT EVERGLADES ENERGY CENTER						
TITLE EXISTING LAND USE						
		PROJECT No. 004703 DESIGN No. 110102H CHECK No. 110301J REVIEW No. 110301K		FILE No. 100702 003 SCALE: AS SHOWN REV. 0		
FIGURE 4						

***Environmental and Land Use Information:
Supplemental Information
Preferred Site #5: Hendry County***

(This page is left intentionally blank.)

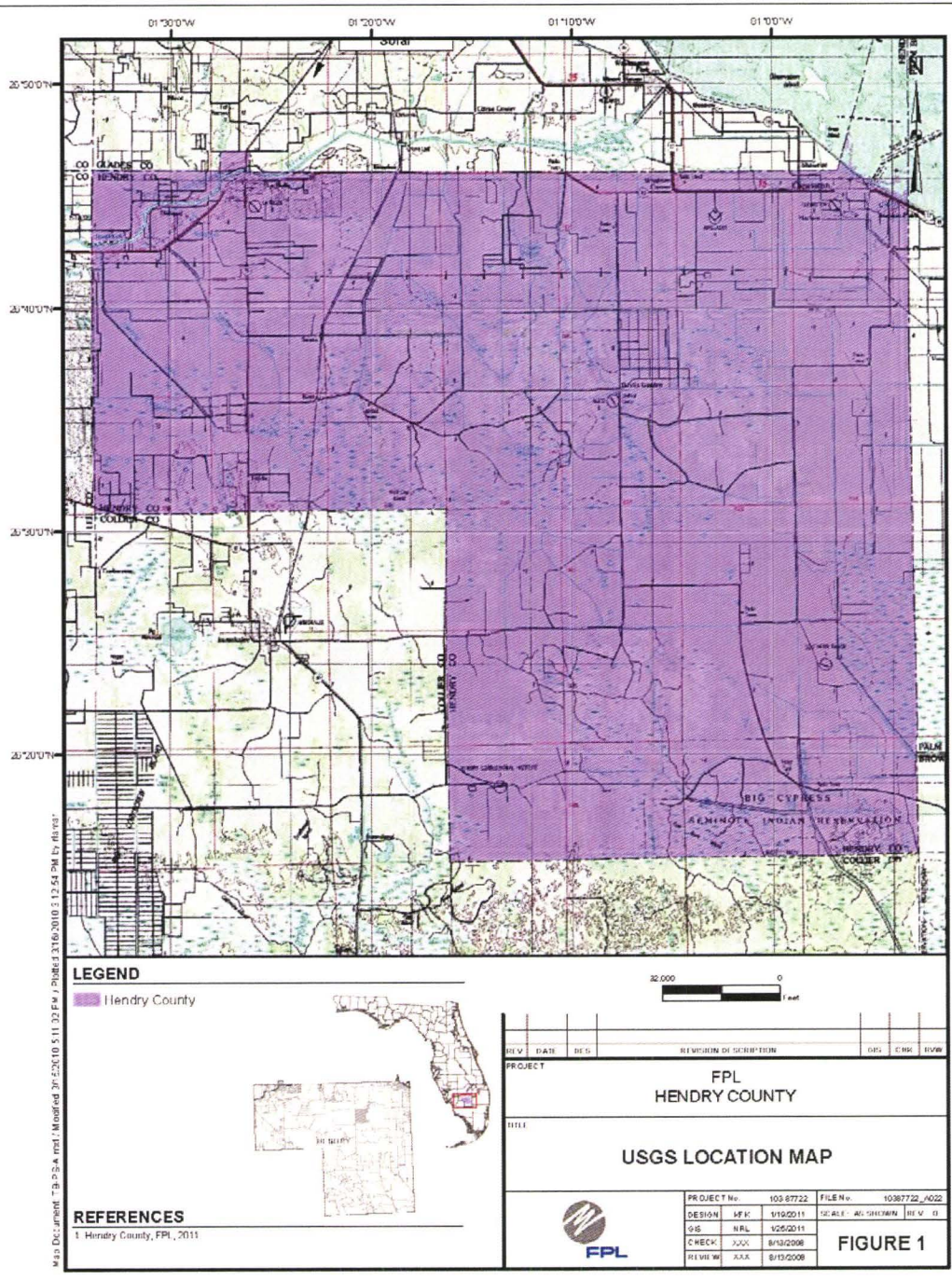

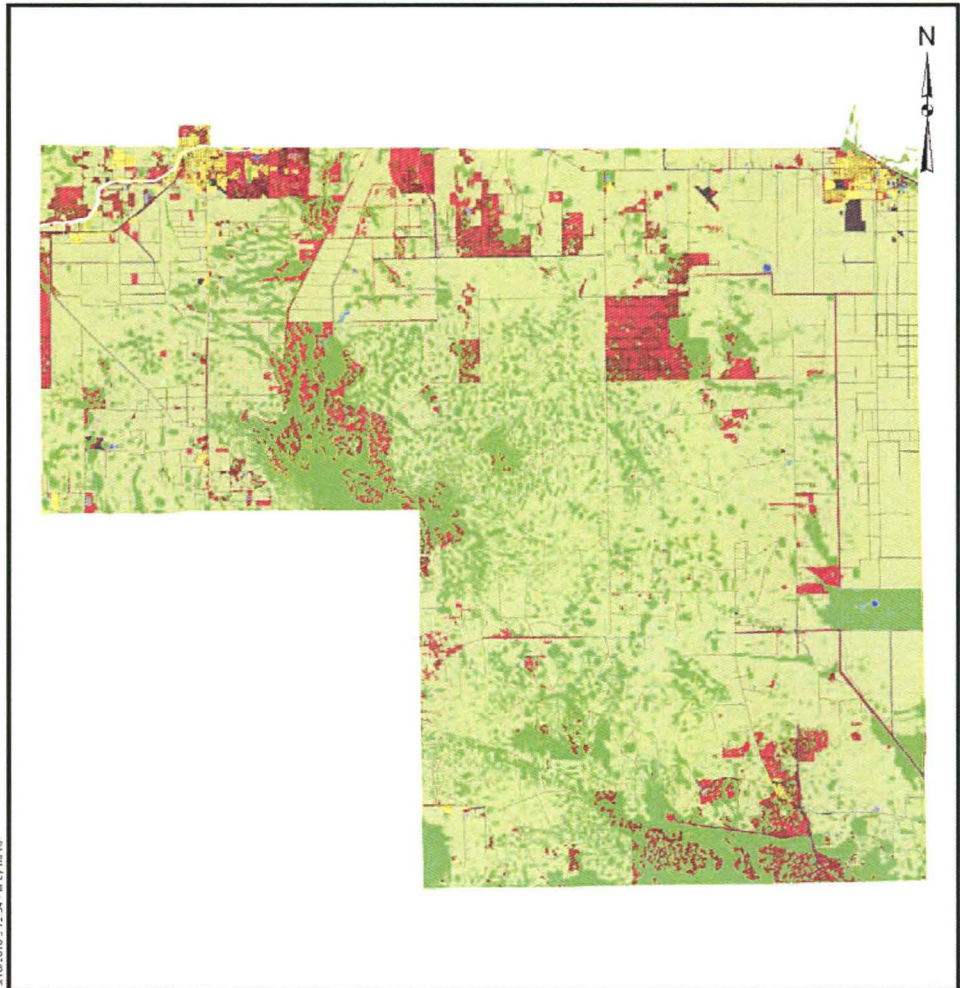

Map Document: P:\P\A\m\l\Modified 3/12/2010 5:11:32 PM / Project: 10387722_001 12:54 PM by: fpl\m

LEGEND

- Roads
- 100 - URBAN AND BUILT-UP
- 200 - AGRICULTURE
- 300 - RANGELAND
- 400 - UPLAND FORESTS
- 500 - WATER
- 600 - WETLANDS
- 700 - BARREN LAND
- 800 - TRANSPORTATION, COMMUNICATION AND UTILITIES

REFERENCES

- 1 Hendry County, FPL, 2011
- 2 Land Use, FVMD FLUCCS, 2004-05



REV	DATE	BY	DESCRIPTION	APP	CHK	BY
PROJECT						
FPL HENDRY COUNTY						
TITLE						
LAND USE / LAND COVER						
PROJECT No.		103 87722		FILE No.		
DESIGN		MFK 1/19/2011		SCALE: AS SHOWN REV: 0		
GIS		NRL 1/25/2011				
CHECK		JJC 8/13/2008		FIGURE 2		
REVIEW		JJK 8/13/2008				



***Environmental and Land Use Information:
Supplemental Information
Preferred Site #6: Northeast Okeechobee County***

(This page is left intentionally blank.)

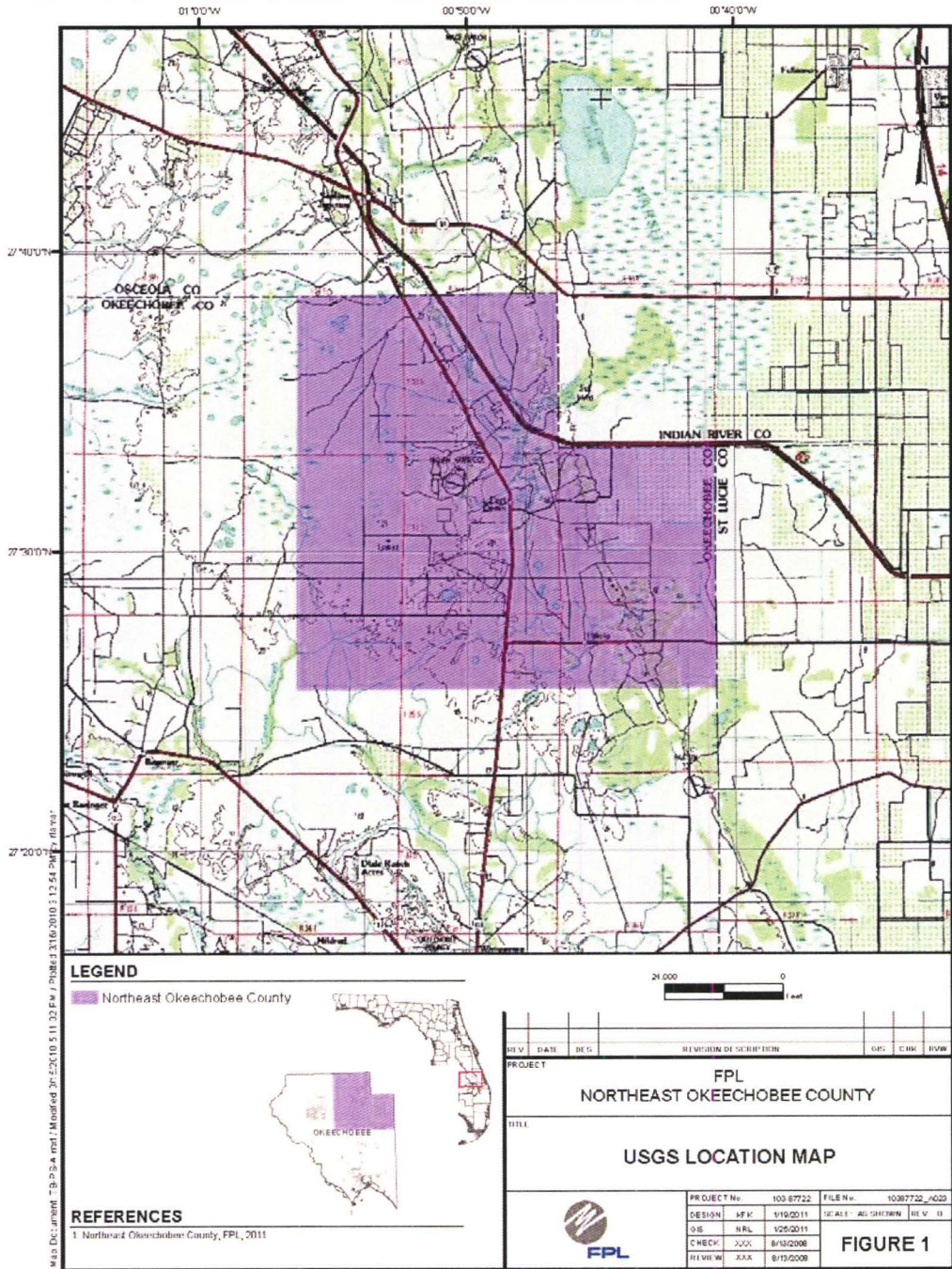

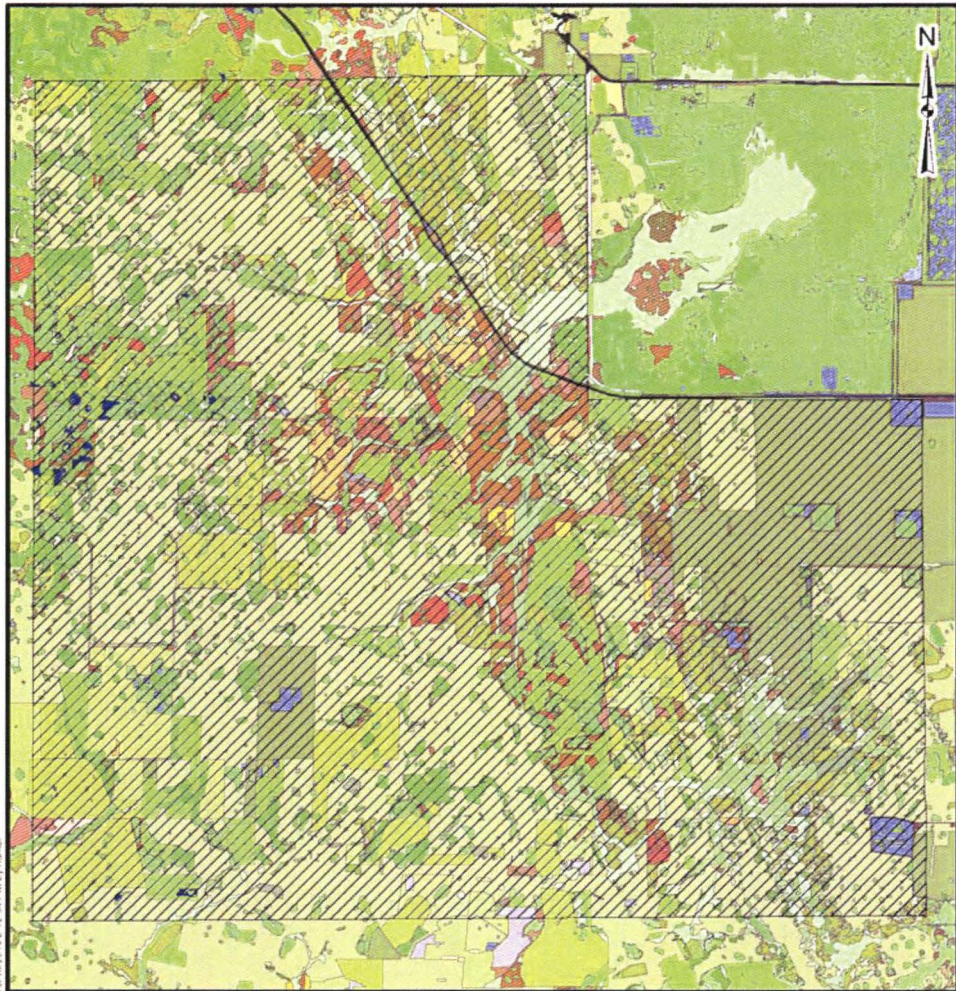

Map Document: T:\S-A\mst\MapDoc\2010-5-11-02-PM\Figured 3162010.3 12:54 PM by rlamar

LEGEND		
020 Wetland (South of Lake County)	240 Churches	410 Rice Soils
025 Residential Low Density	250 Unimproved Farms	415 Mixed Wetland Forestlands
030 Residential Medium Density	260 Vacant Farms	420 Wetland Continuous Forests
035 Forest Single Family Units	265 Dunes	425 Forest
040 Middle Density Units	270 Woodlands	430 Forest Pine
045 Forest Single Family Units	280 Forest Single Land	435 Forest Pine (Cabbage Palm)
050 Middle Density Units	285 Wetlands (Dry Flats)	440 High Pine Forestlands
055 Wetland (Cannal and Wetland)	290 Mixed Nonforest	445 Wetland Limited Mixed
060 Forest Pine	295 Forest Pine	450 Forest Pine
065 Forest Pine	300 Forest Pine	455 Forest Pine (Cabbage Palm)
070 Forest Pine	305 Forest Pine	460 Forest Pine (Cabbage Palm)
075 Forest Pine	310 Forest Pine	465 Forest Pine (Cabbage Palm)
080 Forest Pine	315 Forest Pine	470 Forest Pine (Cabbage Palm)
085 Forest Pine	320 Forest Pine	475 Forest Pine (Cabbage Palm)
090 Forest Pine	325 Forest Pine	480 Forest Pine (Cabbage Palm)
095 Forest Pine	330 Forest Pine	485 Forest Pine (Cabbage Palm)
100 Forest Pine	335 Forest Pine	490 Forest Pine (Cabbage Palm)
105 Forest Pine	340 Forest Pine	495 Forest Pine (Cabbage Palm)
110 Forest Pine	345 Forest Pine	500 Forest Pine (Cabbage Palm)
115 Forest Pine	350 Forest Pine	505 Forest Pine (Cabbage Palm)
120 Forest Pine	355 Forest Pine	510 Forest Pine (Cabbage Palm)
125 Forest Pine	360 Forest Pine	515 Forest Pine (Cabbage Palm)
130 Forest Pine	365 Forest Pine	520 Forest Pine (Cabbage Palm)
135 Forest Pine	370 Forest Pine	525 Forest Pine (Cabbage Palm)
140 Forest Pine	375 Forest Pine	530 Forest Pine (Cabbage Palm)
145 Forest Pine	380 Forest Pine	535 Forest Pine (Cabbage Palm)
150 Forest Pine	385 Forest Pine	540 Forest Pine (Cabbage Palm)
155 Forest Pine	390 Forest Pine	545 Forest Pine (Cabbage Palm)
160 Forest Pine	395 Forest Pine	550 Forest Pine (Cabbage Palm)
165 Forest Pine	400 Forest Pine	555 Forest Pine (Cabbage Palm)
170 Forest Pine	405 Forest Pine	560 Forest Pine (Cabbage Palm)
175 Forest Pine	410 Forest Pine	565 Forest Pine (Cabbage Palm)
180 Forest Pine	415 Forest Pine	570 Forest Pine (Cabbage Palm)
185 Forest Pine	420 Forest Pine	575 Forest Pine (Cabbage Palm)
190 Forest Pine	425 Forest Pine	580 Forest Pine (Cabbage Palm)
195 Forest Pine	430 Forest Pine	585 Forest Pine (Cabbage Palm)
200 Forest Pine	435 Forest Pine	590 Forest Pine (Cabbage Palm)
205 Forest Pine	440 Forest Pine	595 Forest Pine (Cabbage Palm)
210 Forest Pine	445 Forest Pine	600 Forest Pine (Cabbage Palm)
215 Forest Pine	450 Forest Pine	605 Forest Pine (Cabbage Palm)
220 Forest Pine	455 Forest Pine	610 Forest Pine (Cabbage Palm)
225 Forest Pine	460 Forest Pine	615 Forest Pine (Cabbage Palm)
230 Forest Pine	465 Forest Pine	620 Forest Pine (Cabbage Palm)
235 Forest Pine	470 Forest Pine	625 Forest Pine (Cabbage Palm)
240 Forest Pine	475 Forest Pine	630 Forest Pine (Cabbage Palm)
245 Forest Pine	480 Forest Pine	635 Forest Pine (Cabbage Palm)
250 Forest Pine	485 Forest Pine	640 Forest Pine (Cabbage Palm)
255 Forest Pine	490 Forest Pine	645 Forest Pine (Cabbage Palm)
260 Forest Pine	495 Forest Pine	650 Forest Pine (Cabbage Palm)
265 Forest Pine	500 Forest Pine	655 Forest Pine (Cabbage Palm)
270 Forest Pine	505 Forest Pine	660 Forest Pine (Cabbage Palm)
275 Forest Pine	510 Forest Pine	665 Forest Pine (Cabbage Palm)
280 Forest Pine	515 Forest Pine	670 Forest Pine (Cabbage Palm)
285 Forest Pine	520 Forest Pine	675 Forest Pine (Cabbage Palm)
290 Forest Pine	525 Forest Pine	680 Forest Pine (Cabbage Palm)
295 Forest Pine	530 Forest Pine	685 Forest Pine (Cabbage Palm)
300 Forest Pine	535 Forest Pine	690 Forest Pine (Cabbage Palm)
305 Forest Pine	540 Forest Pine	695 Forest Pine (Cabbage Palm)
310 Forest Pine	545 Forest Pine	700 Forest Pine (Cabbage Palm)
315 Forest Pine	550 Forest Pine	705 Forest Pine (Cabbage Palm)
320 Forest Pine	555 Forest Pine	710 Forest Pine (Cabbage Palm)
325 Forest Pine	560 Forest Pine	715 Forest Pine (Cabbage Palm)
330 Forest Pine	565 Forest Pine	720 Forest Pine (Cabbage Palm)
335 Forest Pine	570 Forest Pine	725 Forest Pine (Cabbage Palm)
340 Forest Pine	575 Forest Pine	730 Forest Pine (Cabbage Palm)
345 Forest Pine	580 Forest Pine	735 Forest Pine (Cabbage Palm)
350 Forest Pine	585 Forest Pine	740 Forest Pine (Cabbage Palm)
355 Forest Pine	590 Forest Pine	745 Forest Pine (Cabbage Palm)
360 Forest Pine	595 Forest Pine	750 Forest Pine (Cabbage Palm)
365 Forest Pine	600 Forest Pine	755 Forest Pine (Cabbage Palm)
370 Forest Pine	605 Forest Pine	760 Forest Pine (Cabbage Palm)
375 Forest Pine	610 Forest Pine	765 Forest Pine (Cabbage Palm)
380 Forest Pine	615 Forest Pine	770 Forest Pine (Cabbage Palm)
385 Forest Pine	620 Forest Pine	775 Forest Pine (Cabbage Palm)
390 Forest Pine	625 Forest Pine	780 Forest Pine (Cabbage Palm)
395 Forest Pine	630 Forest Pine	785 Forest Pine (Cabbage Palm)
400 Forest Pine	635 Forest Pine	790 Forest Pine (Cabbage Palm)
405 Forest Pine	640 Forest Pine	795 Forest Pine (Cabbage Palm)
410 Forest Pine	645 Forest Pine	800 Forest Pine (Cabbage Palm)
415 Forest Pine	650 Forest Pine	805 Forest Pine (Cabbage Palm)
420 Forest Pine	655 Forest Pine	810 Forest Pine (Cabbage Palm)
425 Forest Pine	660 Forest Pine	815 Forest Pine (Cabbage Palm)
430 Forest Pine	665 Forest Pine	820 Forest Pine (Cabbage Palm)
435 Forest Pine	670 Forest Pine	825 Forest Pine (Cabbage Palm)
440 Forest Pine	675 Forest Pine	830 Forest Pine (Cabbage Palm)
445 Forest Pine	680 Forest Pine	835 Forest Pine (Cabbage Palm)
450 Forest Pine	685 Forest Pine	840 Forest Pine (Cabbage Palm)
455 Forest Pine	690 Forest Pine	845 Forest Pine (Cabbage Palm)
460 Forest Pine	695 Forest Pine	850 Forest Pine (Cabbage Palm)
465 Forest Pine	700 Forest Pine	855 Forest Pine (Cabbage Palm)
470 Forest Pine	705 Forest Pine	860 Forest Pine (Cabbage Palm)
475 Forest Pine	710 Forest Pine	865 Forest Pine (Cabbage Palm)
480 Forest Pine	715 Forest Pine	870 Forest Pine (Cabbage Palm)
485 Forest Pine	720 Forest Pine	875 Forest Pine (Cabbage Palm)
490 Forest Pine	725 Forest Pine	880 Forest Pine (Cabbage Palm)
495 Forest Pine	730 Forest Pine	885 Forest Pine (Cabbage Palm)
500 Forest Pine	735 Forest Pine	890 Forest Pine (Cabbage Palm)
505 Forest Pine	740 Forest Pine	895 Forest Pine (Cabbage Palm)
510 Forest Pine	745 Forest Pine	900 Forest Pine (Cabbage Palm)
515 Forest Pine	750 Forest Pine	905 Forest Pine (Cabbage Palm)
520 Forest Pine	755 Forest Pine	910 Forest Pine (Cabbage Palm)
525 Forest Pine	760 Forest Pine	915 Forest Pine (Cabbage Palm)
530 Forest Pine	765 Forest Pine	920 Forest Pine (Cabbage Palm)
535 Forest Pine	770 Forest Pine	925 Forest Pine (Cabbage Palm)
540 Forest Pine	775 Forest Pine	930 Forest Pine (Cabbage Palm)
545 Forest Pine	780 Forest Pine	935 Forest Pine (Cabbage Palm)
550 Forest Pine	785 Forest Pine	940 Forest Pine (Cabbage Palm)
555 Forest Pine	790 Forest Pine	945 Forest Pine (Cabbage Palm)
560 Forest Pine	795 Forest Pine	950 Forest Pine (Cabbage Palm)
565 Forest Pine	800 Forest Pine	955 Forest Pine (Cabbage Palm)
570 Forest Pine	805 Forest Pine	960 Forest Pine (Cabbage Palm)
575 Forest Pine	810 Forest Pine	965 Forest Pine (Cabbage Palm)
580 Forest Pine	815 Forest Pine	970 Forest Pine (Cabbage Palm)
585 Forest Pine	820 Forest Pine	975 Forest Pine (Cabbage Palm)
590 Forest Pine	825 Forest Pine	980 Forest Pine (Cabbage Palm)
595 Forest Pine	830 Forest Pine	985 Forest Pine (Cabbage Palm)
600 Forest Pine	835 Forest Pine	990 Forest Pine (Cabbage Palm)
605 Forest Pine	840 Forest Pine	995 Forest Pine (Cabbage Palm)
610 Forest Pine	845 Forest Pine	1000 Forest Pine (Cabbage Palm)

REFERENCES	
1	Northeast Okeechobee County FPL 2011
2	Land Use, SF-VMD & SJRVMD 2004-05

REV	DATE	DES	REVISION DESCRIPTION	GIS	CHK	REV
PROJECT: FPL NORTHEAST OKEECHOBEE COUNTY						
TITLE: LAND USE / LAND COVER						
PROJECT No: 101-87722		FILE No: 10307722_40.05				
DESIGN	KFR	1/15/2011	SCALE AS SHOWN	REV	0	
GIS	NRL	1/26/2011				
CHECK	XXX	8/13/2008				
REVIEW	XXX	8/13/2008				

FIGURE 2

***Environmental and Land Use Information:
Supplemental Information
Preferred Site #7: Palatka Site***

(This page is left intentionally blank.)



Map Document: I:\P\SA.mxd / Mod Date: 3/15/2013 11:02 PM / Pld Date: 3/15/2013 11:02 PM / Pld Date: 3/15/2013 11:02 PM / Pld Date: 3/15/2013 11:02 PM

LEGEND

Palatka Site

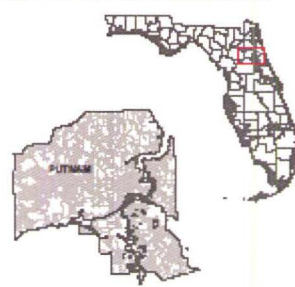

REFERENCES

1. Palatka Site, FPL, 2011.

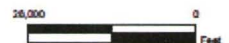

REV.	DATE	DES.	REVISION DESCRIPTION	GIS	CHK	RVW
PROJECT			FPL PALATKA SITE			
TITLE						
USGS LOCATION MAP						
PROJECT No.		100-87722		FILE No.		10087722_C028
DESIGN	KTK	1/18/2011		SCALE:	AS SHOWN (REV. 0)	
GIS	NRL	3/4/2013		FIGURE 1		
CHECK	KTK	3/4/2013				
REVIEW	KTK	3/4/2013				



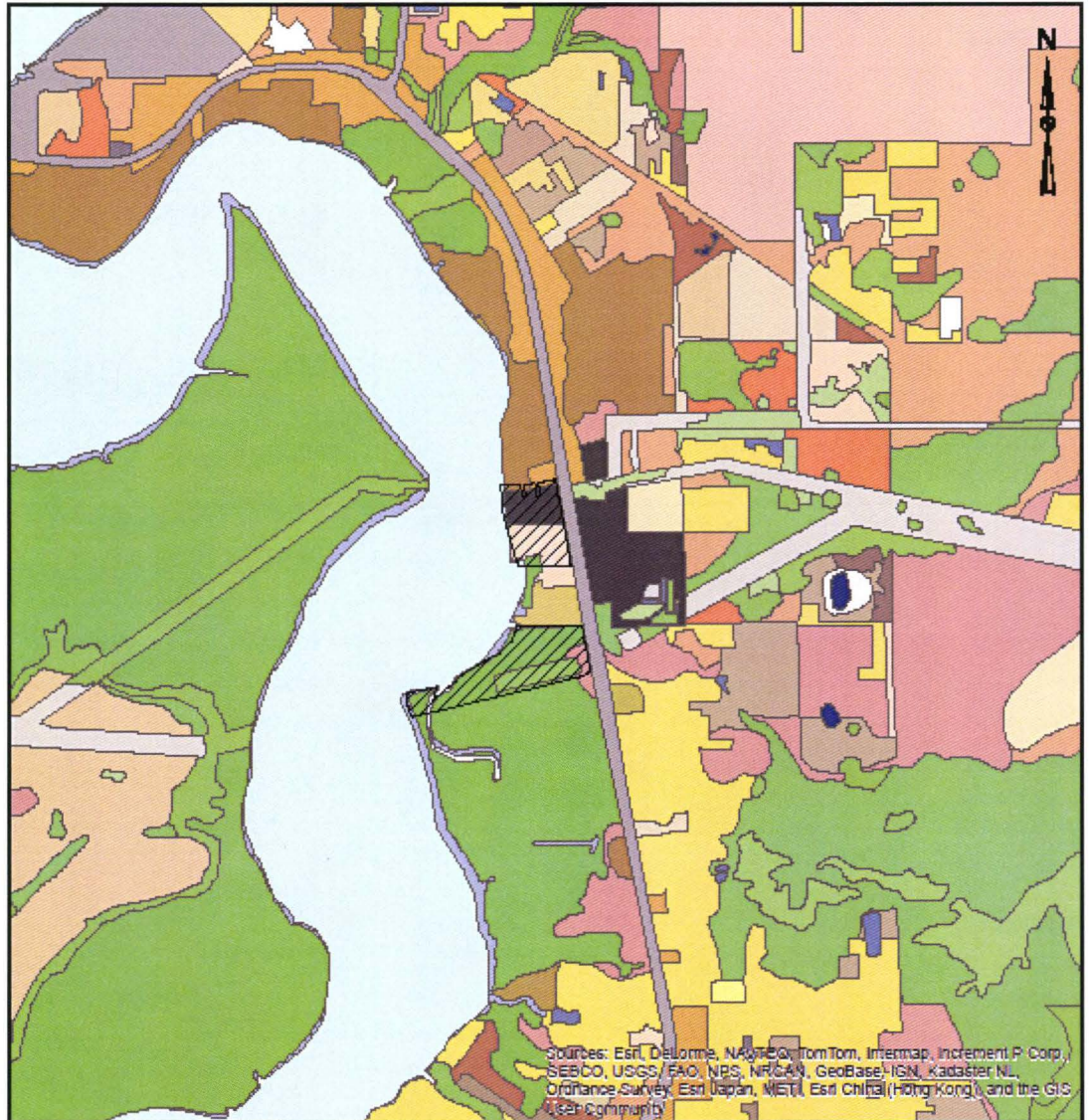

Sources: Esri, DeLorme, NAVTEQ, TomTom, Intermap, increment P Corp, SEBCO, USGS/FAO, NPS, NRCAN, GeoBase, IGN, Kadaster NL, Ordnance Survey, Esri Japan, METI, Esri China (Hong Kong), and the GIS User Community

LEGEND

- | | | |
|--|---|--|
| <ul style="list-style-type: none"> Public Site Land Use / Land Cover 10: Pastureland, Low Density 11: Pastureland, Medium Density 12: Pastureland, High Density 13: Commercial and Services 14: Open Space 15: Wetland 16: Wetland 17: Wetland 18: Wetland 19: Wetland 20: Wetland 21: Wetland 22: Wetland 23: Wetland 24: Wetland 25: Wetland 26: Wetland 27: Wetland 28: Wetland 29: Wetland 30: Wetland 31: Wetland 32: Wetland 33: Wetland 34: Wetland 35: Wetland 36: Wetland 37: Wetland 38: Wetland 39: Wetland 40: Wetland 41: Wetland 42: Wetland 43: Wetland 44: Wetland 45: Wetland 46: Wetland 47: Wetland 48: Wetland 49: Wetland 50: Wetland 51: Wetland 52: Wetland 53: Wetland 54: Wetland 55: Wetland 56: Wetland 57: Wetland 58: Wetland 59: Wetland 60: Wetland 61: Wetland 62: Wetland 63: Wetland 64: Wetland 65: Wetland 66: Wetland 67: Wetland 68: Wetland 69: Wetland 70: Wetland 71: Wetland 72: Wetland 73: Wetland 74: Wetland 75: Wetland 76: Wetland 77: Wetland 78: Wetland 79: Wetland 80: Wetland 81: Wetland 82: Wetland 83: Wetland 84: Wetland 85: Wetland 86: Wetland 87: Wetland 88: Wetland 89: Wetland 90: Wetland 91: Wetland 92: Wetland 93: Wetland 94: Wetland 95: Wetland 96: Wetland 97: Wetland 98: Wetland 99: Wetland 100: Wetland | <ul style="list-style-type: none"> 211: Impervious Pasture 212: Unimpervious Pasture 213: Woodland Pasture 214: Rice Crops 215: Field Crops 216: Rice Crops 217: Rice Crops 218: Rice Crops 219: Rice Crops 220: Rice Crops 221: Rice Crops 222: Rice Crops 223: Rice Crops 224: Rice Crops 225: Rice Crops 226: Rice Crops 227: Rice Crops 228: Rice Crops 229: Rice Crops 230: Rice Crops 231: Rice Crops 232: Rice Crops 233: Rice Crops 234: Rice Crops 235: Rice Crops 236: Rice Crops 237: Rice Crops 238: Rice Crops 239: Rice Crops 240: Rice Crops 241: Rice Crops 242: Rice Crops 243: Rice Crops 244: Rice Crops 245: Rice Crops 246: Rice Crops 247: Rice Crops 248: Rice Crops 249: Rice Crops 250: Rice Crops 251: Rice Crops 252: Rice Crops 253: Rice Crops 254: Rice Crops 255: Rice Crops 256: Rice Crops 257: Rice Crops 258: Rice Crops 259: Rice Crops 260: Rice Crops 261: Rice Crops 262: Rice Crops 263: Rice Crops 264: Rice Crops 265: Rice Crops 266: Rice Crops 267: Rice Crops 268: Rice Crops 269: Rice Crops 270: Rice Crops 271: Rice Crops 272: Rice Crops 273: Rice Crops 274: Rice Crops 275: Rice Crops 276: Rice Crops 277: Rice Crops 278: Rice Crops 279: Rice Crops 280: Rice Crops 281: Rice Crops 282: Rice Crops 283: Rice Crops 284: Rice Crops 285: Rice Crops 286: Rice Crops 287: Rice Crops 288: Rice Crops 289: Rice Crops 290: Rice Crops 291: Rice Crops 292: Rice Crops 293: Rice Crops 294: Rice Crops 295: Rice Crops 296: Rice Crops 297: Rice Crops 298: Rice Crops 299: Rice Crops 300: Rice Crops | <ul style="list-style-type: none"> 301: Rice Crops 302: Rice Crops 303: Rice Crops 304: Rice Crops 305: Rice Crops 306: Rice Crops 307: Rice Crops 308: Rice Crops 309: Rice Crops 310: Rice Crops 311: Rice Crops 312: Rice Crops 313: Rice Crops 314: Rice Crops 315: Rice Crops 316: Rice Crops 317: Rice Crops 318: Rice Crops 319: Rice Crops 320: Rice Crops 321: Rice Crops 322: Rice Crops 323: Rice Crops 324: Rice Crops 325: Rice Crops 326: Rice Crops 327: Rice Crops 328: Rice Crops 329: Rice Crops 330: Rice Crops 331: Rice Crops 332: Rice Crops 333: Rice Crops 334: Rice Crops 335: Rice Crops 336: Rice Crops 337: Rice Crops 338: Rice Crops 339: Rice Crops 340: Rice Crops 341: Rice Crops 342: Rice Crops 343: Rice Crops 344: Rice Crops 345: Rice Crops 346: Rice Crops 347: Rice Crops 348: Rice Crops 349: Rice Crops 350: Rice Crops 351: Rice Crops 352: Rice Crops 353: Rice Crops 354: Rice Crops 355: Rice Crops 356: Rice Crops 357: Rice Crops 358: Rice Crops 359: Rice Crops 360: Rice Crops 361: Rice Crops 362: Rice Crops 363: Rice Crops 364: Rice Crops 365: Rice Crops 366: Rice Crops 367: Rice Crops 368: Rice Crops 369: Rice Crops 370: Rice Crops 371: Rice Crops 372: Rice Crops 373: Rice Crops 374: Rice Crops 375: Rice Crops 376: Rice Crops 377: Rice Crops 378: Rice Crops 379: Rice Crops 380: Rice Crops 381: Rice Crops 382: Rice Crops 383: Rice Crops 384: Rice Crops 385: Rice Crops 386: Rice Crops 387: Rice Crops 388: Rice Crops 389: Rice Crops 390: Rice Crops 391: Rice Crops 392: Rice Crops 393: Rice Crops 394: Rice Crops 395: Rice Crops 396: Rice Crops 397: Rice Crops 398: Rice Crops 399: Rice Crops 400: Rice Crops |
|--|---|--|

REFERENCES

1. Palatka Site, FPL, 2011.
2. Land Use / Land Cover, SURWMD, 2009

Document Path:



REV.	DATE	DES.	REVISION DESCRIPTION	GIS	CHK	RVW
PROJECT FPL PALATKA SITE						
TITLE LAND USE / LAND COVER MAP						
PROJECT No.		100-87722		FILE No.		10087722_C010
DESIGN		KFK 1/8/2011		SCALE		AS SHOWN REV. 0
GIS		NRL 3/4/2013		FIGURE 3		
CHECK		KFK 3/4/2013				
REVIEW		KFK 3/4/2013				



***Environmental and Land Use Information:
Supplemental Information***

Potential Site #1: Babcock Ranch

(This page is left intentionally blank.)

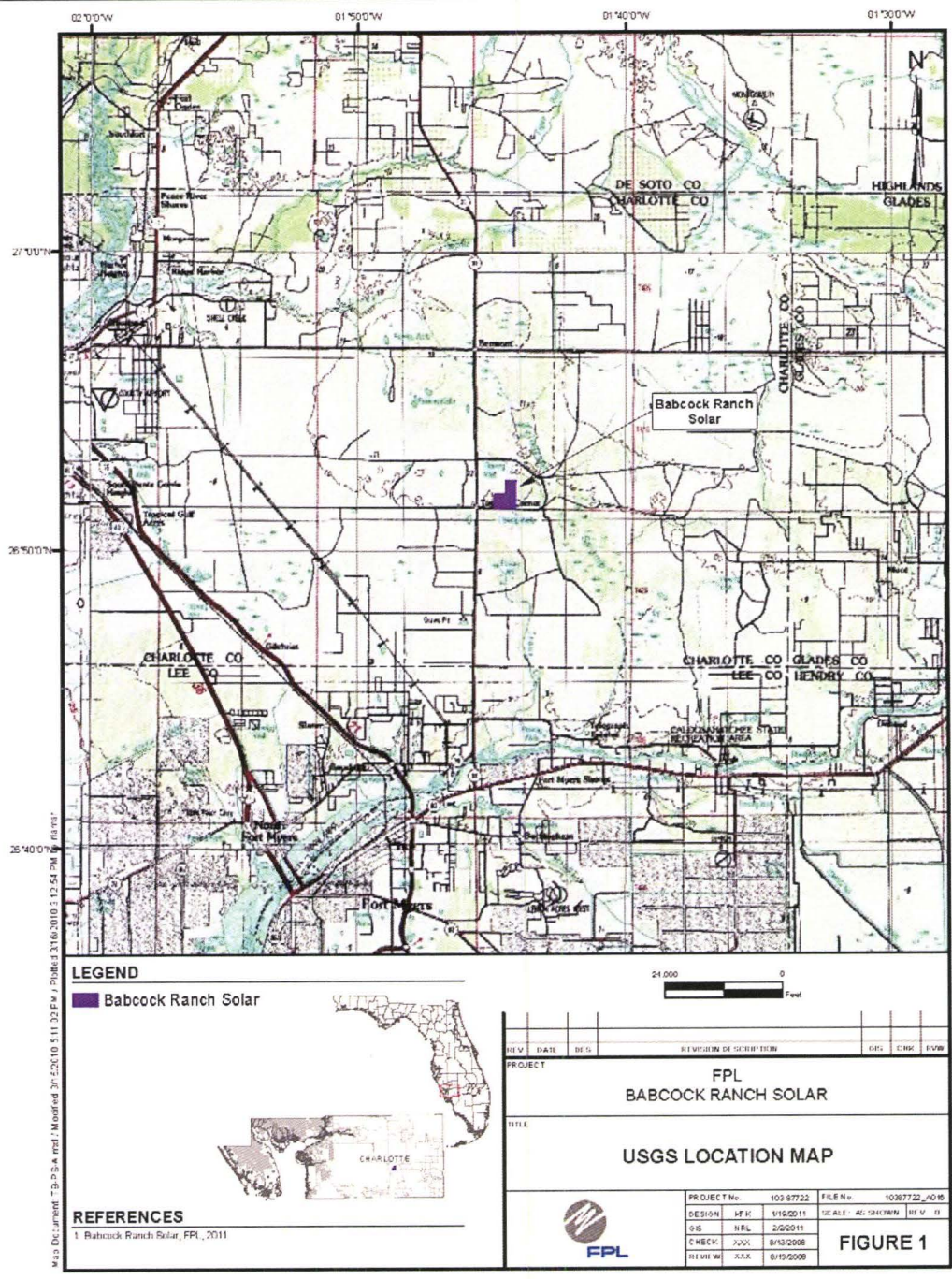



Map Document: "B:\2011\10\10\10_11_10_11.dwg" Plotted: 2/16/2011 3:12:54 PM by dfrank

LEGEND

- Roads
- Babcock Ranch Solar
- 211 - Improved Pastures
- 212 - Unimproved Pastures
- 213 - Woodland Pastures
- 215 - Field Crops
- 310 - Herbaceous (Dry Prairie)
- 320 - Shrub and Rangeland
- 321 - Palmbed Prairies
- 330 - Mixed Rangeland
- 411 - Pine Flatwoods
- 441 - Coniferous Plantations
- 443 - Forest Regeneration Areas
- 525 - Marshy Lakes
- U17 - Mixed Wetland Hardwoods
- U21 - Cypress
- U24 - Cypress/Pine Cabbage Palm
- U26 - Hydric Pine Flatwoods
- R30 - Wetland Forested Mixed
- R41 - Freshwater Marshes
- 643 - Wet Prairies

REFERENCES

- 1 Babcock Ranch Solar, FPL, 2011
- 2 Land Use, FWMD FLUCCS, 2004 DS



REV	DATE	BY	REVISION DESCRIPTION	DES	CHK	APP
PROJECT						
FPL BABCOCK RANCH SOLAR						
TITLE						
LAND USE / LAND COVER						
PROJECT No.		103 87722		FILE No.		10387722_#028
DESIGN	WFK	1/10/2011	SCALE	AS SHOWN	REV	0
GIS	NRL	2/22/11				
CHECK	JXX	8/13/2008				
REVIEW	JXX	8/13/2008				
FIGURE 2						

***Environmental and Land Use Information:
Supplemental Information***

Potential Site #2: Desoto Solar Expansion

(This page is left intentionally blank.)

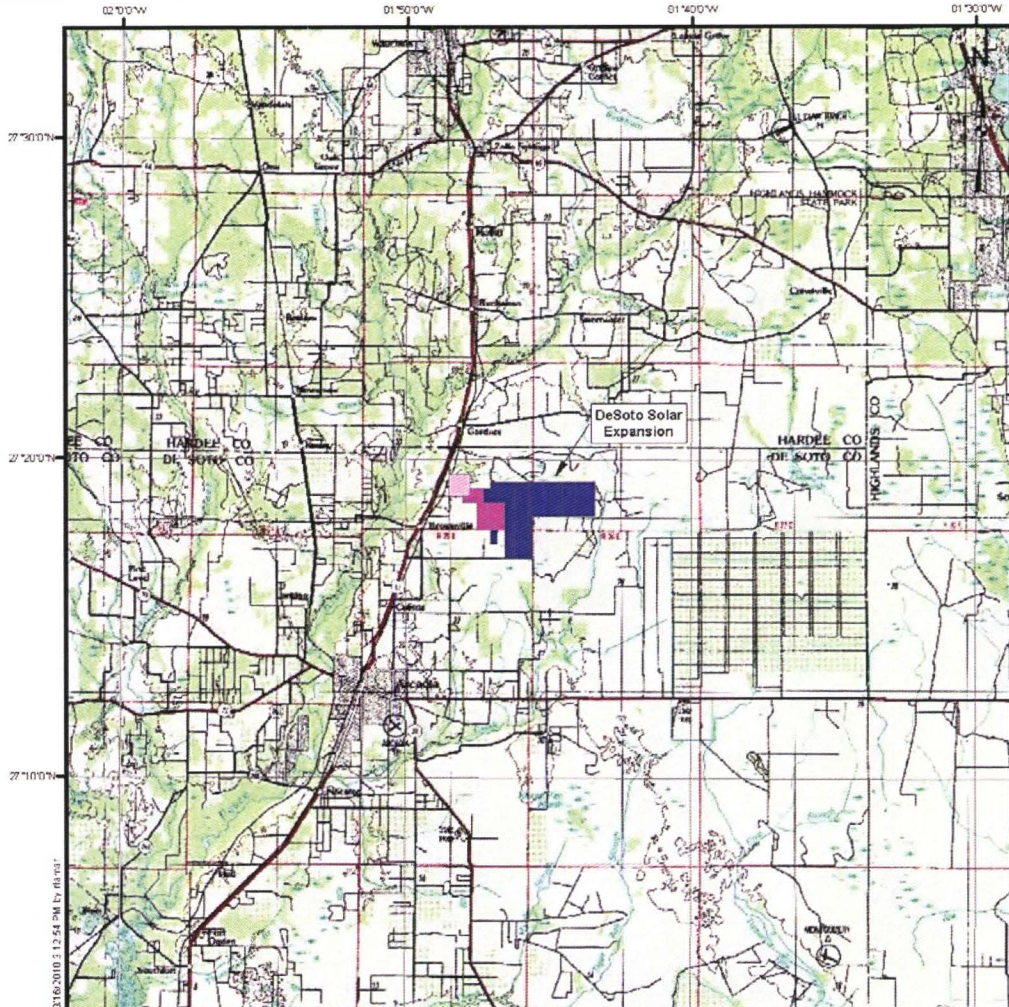

LEGEND

- DeSoto Solar Project Phase I
- DeSoto Solar Project Expansion Phase II
- DeSoto Solar Project Expansion Phase III

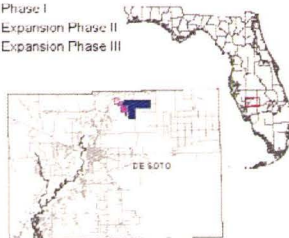

REFERENCES

1 DeSoto Solar Expansion, FPL, 2011



REV	DATE	BY	DESCRIPTION	DES	CHEK	BYWH	
PROJECT							
FPL DESOTO SOLAR EXPANSION							
TITLE							
USGS LOCATION MAP							
		PROJECT No.	105-87722	FILE No.	10387722_0017		
		DESIGN	SFK	1/10/2011	SCALE	AS SHOWN	REV. 0
		GIS	NRL	2/2/2011			
		CHECK	JXX	8/13/2008			
REVIEW	JXX	8/13/2008					
FIGURE 1							

Map Document: 10-25-11.mxd Modified: 3/1/2010 5:11:30 PM / Printed: 3/16/2010 1:25:48 PM by: fpl

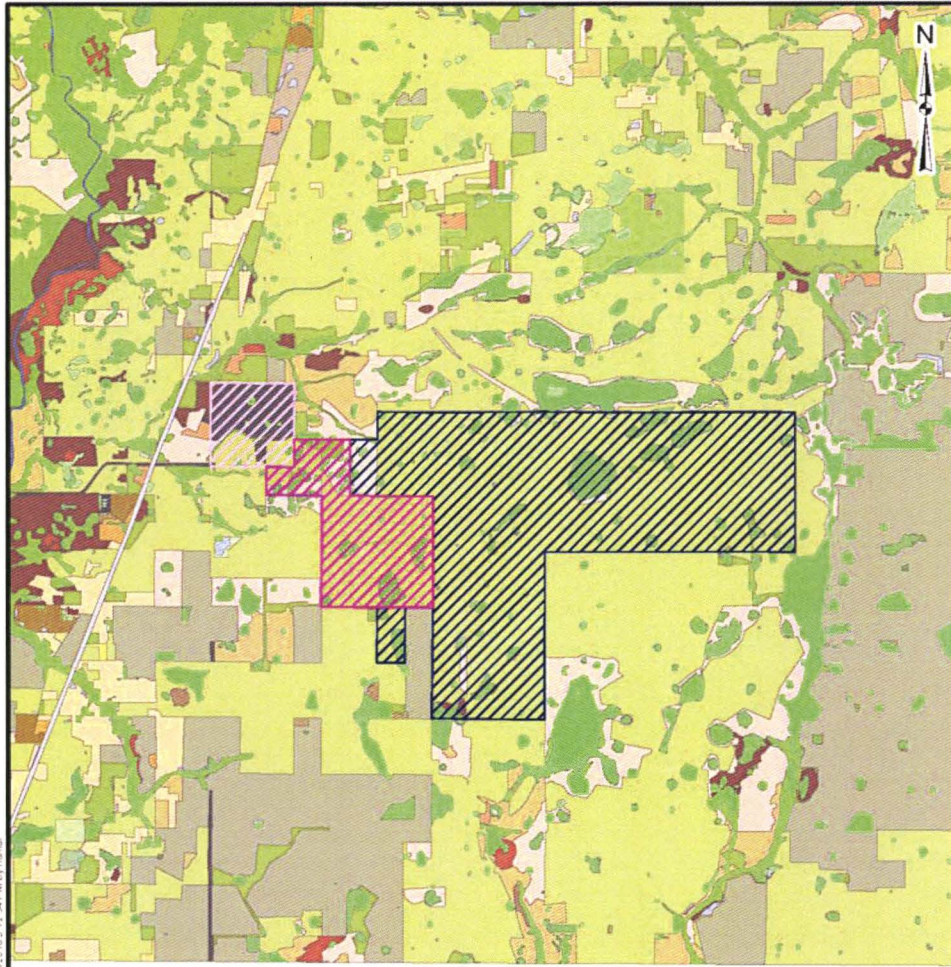

Map Document: TELP_Solar_Expansion_10102011.dwg Plot Date: 10/10/2011 10:54:48 AM by: jmmar

LEGEND

DeSoto Solar Project Phase I	330 MIXED WETLAND
DeSoto Solar Project Expansion Phase I	410 UPLAND CONIFEROUS FOREST
DeSoto Solar Project Expansion Phase II	471 PINE FL. WETLANDS
110 RESIDENTIAL LOW DENSITY - 2 DWELLING UNITS	474 HARDWOOD CONIFER MIXED
120 RESIDENTIAL MED DENSITY - 2 DWELLING UNITS	440 TREE PLANTATION
130 RESIDENTIAL HIGH DENSITY	510 STREAM AND WATERWAYS
140 COMMERCIAL AND SERVICES	520 LAKE
150 INDUSTRIAL	530 BEECH PINE
160 GOLF COURSES	615 STREAM AND LAKE SWAMPS (BOTTOMLAND)
190 OPEN LAND	620 WETLAND CONIFEROUS FORESTS
210 CROPLAND AND PASTURELAND	621 C. PINESS
220 TREE CRUISE	630 WETLAND FORESTED MIXED
240 NURSERY AND VINEYARDS	641 FRESHWATER MARSHES
250 SPECIALTY FARMS	642 PINE SWAMP
255 TROPICAL FISH FARMS	644 EMERGENT AQUATIC VEGETATION
260 OTHER OPENLAND - RURAL	653 INTERMITTENT PONDS
370 WETLANDS	655 TRANSPORTATION
320 SHRUB AND BRUSHLAND	650 UTILITIES

REFERENCES

- 1 DeSoto Solar Expansion: FPL, 2011
- 2 Land Use: SWFWMD, 2009



REV	DATE	DES	REVISION DESCRIPTION	GIS	CHK	REV	
PROJECT							
FPL DESOTO SOLAR EXPANSION							
TITLE							
LAND USE / LAND COVER							
		PROJECT No	103-67722	FILE No	10367722_4029		
		DESIGN	KFK	1/15/2011	SCALE	AS SHOWN	
		GIS	NRL	2/2/2011	REV	0	
		CHECK	XXX	6/13/2008	FIGURE 2		
REVIEW	XXX	6/13/2008					

***Environmental and Land Use Information:
Supplemental Information***

Potential Site #3: Manatee Plant Site

(This page is left intentionally blank.)



Map Doc: mmet_T9-PS-A.mxd / Modified: 3/12/2010 3:12:54 PM / Plotted: 3/16/2010 3:12:54 PM by dbrax

LEGEND

Manatee Solar

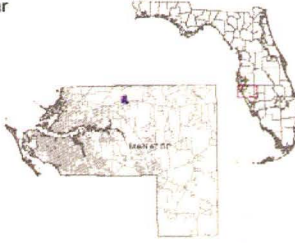

REFERENCES

1. Manatee Solar, FPL, 2011



REV	DATE	DES	REVISION DESCRIPTION	GIS	CHK	REV
PROJECT						
FPL MANATEE SOLAR						
TITLE						
USGS LOCATION MAP						
PROJECT No.		103.87722	FILE No.		10387722_0010	
DESIGN	NFL	5/19/2011	SCALE	AS SHOWN	REV. 0	
GIS	NRL	5/25/2011				
CHECK	XXX	6/13/2008	FIGURE 1			
REVIEW	AXX	8/13/2008				





Map Document: T:\9-2-11\Map\10-511-20-EM / Project: 1016-2000-12-54 PM by dlsmp

LEGEND

<ul style="list-style-type: none"> 10000 - FIELDS 10001 - Manatee Solar 110 - RESIDENTIAL LOW DENSITY 1 + 2 DWELLING UNITS 120 - RESIDENTIAL MED DENSITY 2 - 4 DWELLING UNITS 160 - INDUSTRIAL 180 - OPEN LAND 210 - UPLAND AND PASTURELAND 214 - ROW CROPS 220 - TREE CROPS 240 - NURSERIES AND VITICULTURE 243 - OTHER OPEN LANDS - FURFILL 250 - SUBURB AND BUSHLAND 270 - MIXED RANGELAND 	<ul style="list-style-type: none"> 411 - PINE FLORWOODS 434 - HARDWOOD CONIFER MIXED 440 - TREE PLANTATIONS 510 - STRIPES AND WATERWAYS 520 - LAKES 530 - RESERVOIRS 516 - STREAM AND LAKE SWAMP (BUT DRAINED) 601 - CYPRESS 620 - WETLAND FORESTED MIXED 641 - FRESHWATER MARSHES 643 - WET PRAIRIES 644 - EMERGENT AQUATIC VEGETATION 650 - UTILITIES
--	--

REFERENCES

1. Manatee Solar, FPL, 2011
2. Land Use, SWFWMD, 2009



REV	DATE	DES	REVISION DESCRIPTION	DES	CHK	APP

PROJECT: **FPL MANATEE SOLAR**

TITLE: **LAND USE / LAND COVER**

PROJECT No:	103-8722	FILE No:	10387722_001
DESIGN:	NRL	DATE:	1/19/2011
CHECK:	JCC	DATE:	8/19/2009
REVIEW:	AAA	DATE:	8/19/2009

FIGURE 2

***Environmental and Land Use Information:
Supplemental Information***

Potential Site #4: Martin County

(This page is left intentionally blank.)

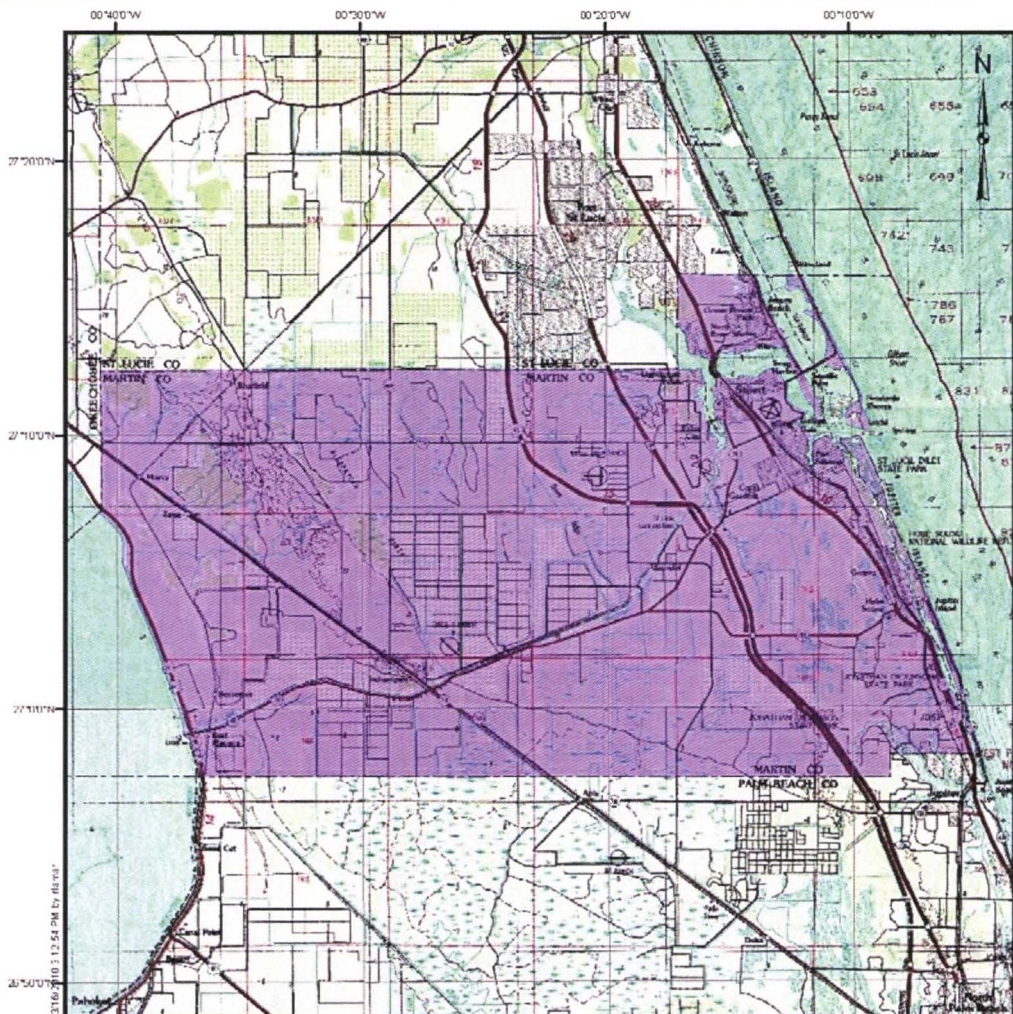

Map Doc: amlent_T19_P2-A.mxd / Modified: 3/15/2011 5:11:32 PM / Plotted: 3/16/2011 12:54:28 PM by rblvay

LEGEND

Martin County

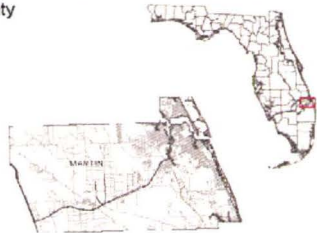

REFERENCES

1. Martin County, FPL, 2011



REV	DATE	DES	REVISION DESCRIPTION	DES	CHKD	BYWH
PROJECT						

FPL
MARTIN COUNTY

TITLE						
USGS LOCATION MAP						



PROJECT No.	100-87722	FILE No.	10387722_0026
DESIGN	HFK	DATE	5/19/2011
DRAWN	NRL	DATE	1/25/2011
CHECKED	JCC	DATE	8/13/2008
REVIEWED	AAA	DATE	8/13/2008

FIGURE 1



Map Document: P:\P\A\mst\Modified 31-2010 5:11:32 PM / Digitized 31-16-2010 3:12:54 PM by rlhmv*

LEGEND

- Roads
- 100 - URBAN AND BUILT-UP
- 200 - AGRICULTURE
- 300 - RANGELAND
- 400 - UPLAND FORESTS
- 500 - WATER
- 600 - WETLANDS
- 700 - BARREN LAND
- 800 - TRANSPORTATION, COMMUNICATION AND UTILITIES

REFERENCES

1. Martin County, FL, 2011
2. Land Use, SFWMD, 2004.05



REV	DATE	DIS	REVISION DESCRIPTION	DWG	CHK	BY

PROJECT: **FPL
MARTIN COUNTY**

TITLE: **LAND USE / LAND COVER**



PROJECT No.	103-87722	FILE No.	10387722_0038
DESIGN	MFK	1/19/2011	SCALE: AS SHOWN
DIS	NRL	1/26/2011	REV: 0
CHECK	JJK	8/13/2008	FIGURE 2
REVISE	JJK	8/13/2008	

***Environmental and Land Use Information:
Supplemental Information***

Potential Site #5: Putnam County

(This page is left intentionally blank.)

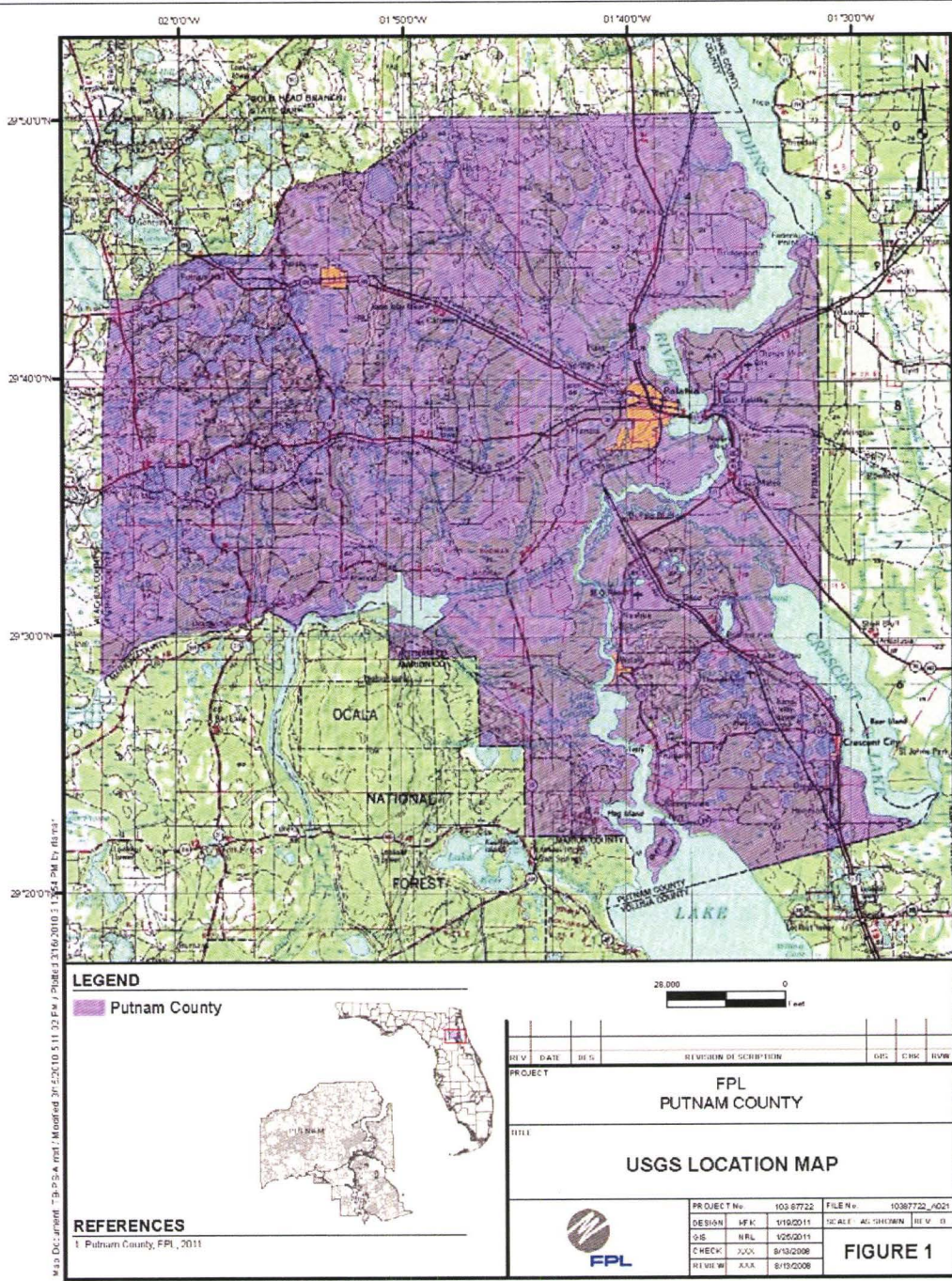

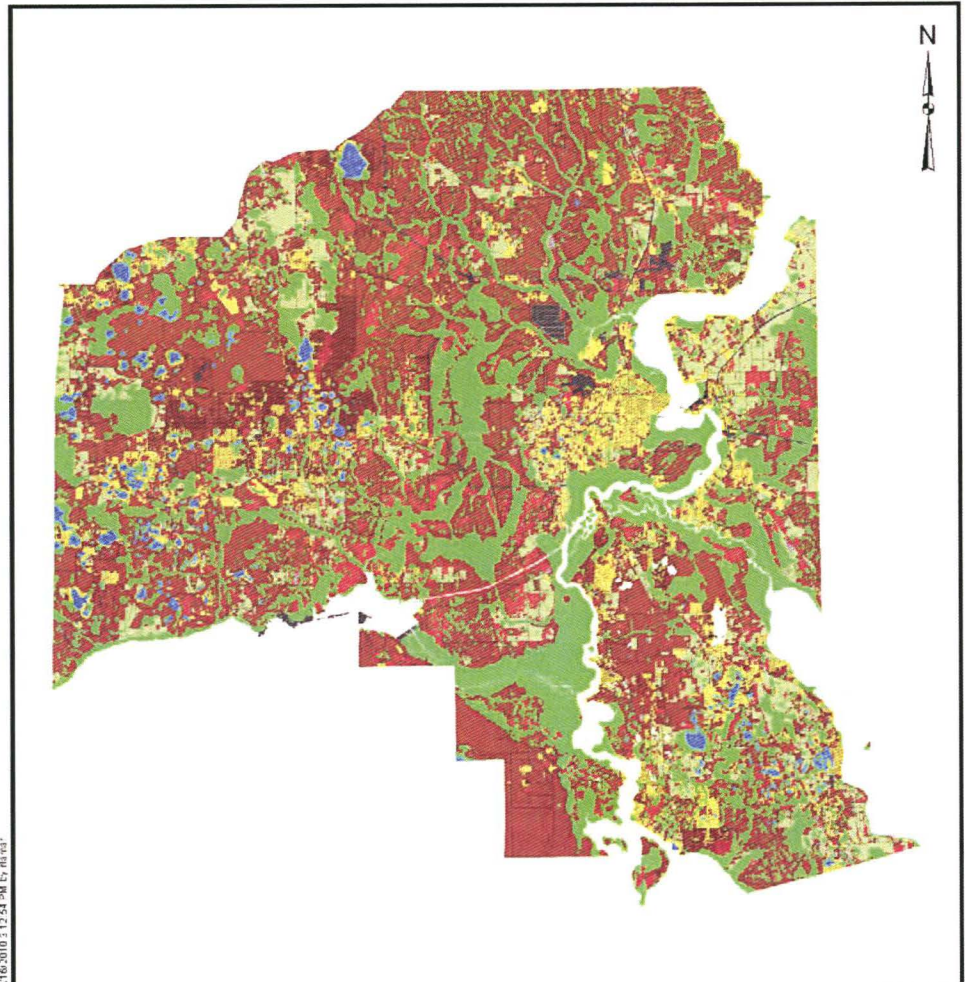

Map Doc: putnam_fpl_2011.mxd Modified: 3/1/2011 5:11:32 PM / Project: 10387722_003 1/25/11 12:54 PM by: fpl/esi

LEGEND

- Roads
- 100 - URBAN AND BUILT UP
- 200 - AGRICULTURE
- 300 - RANGELAND
- 400 - UPLAND FORESTS
- 500 - WATER
- 600 - WETLANDS
- 700 - BARREN LAND
- 800 - TRANSPORTATION, COMMUNICATION AND UTILITIES

REFERENCES

- 1 Putnam County FPL, 2011
- 2 Land Use, SJRWMD, 2004



REV	DATE	BY	DESCRIPTION	QCS	CHK	BYW	
PROJECT							
FPL PUTNAM COUNTY							
TITLE							
LAND USE / LAND COVER							
		PROJECT No.	103 87722	FILE No.	10387722_0030		
		DESIGN	WFK	5/15/2011	SCALE:	AS SHOWN	
		GIS	NPL	5/25/2011	REV:	0	
		CHECK	JJJ	8/13/2008	FIGURE 2		
REVIEW	XXX	8/13/2008					

CHAPTER V

Other Planning Assumptions & Information

(This page is left intentionally blank.)

Introduction

The Florida Public Service Commission (FPSC), in Docket No. 960111-EU, specified certain information that was to be included in an electric utility's Ten Year Power Plant Site Plan filing. Among this specified information was a group of 12 items listed under a heading entitled "Other Planning Assumptions and Information." These 12 items basically concern specific aspects of a utility's resource planning work. The FPSC requested a discussion or a description of each of these items.

These 12 items are addressed individually below as separate "Discussion Items".

Discussion Item # 1: Describe how any transmission constraints were modeled and explain the impacts on the plan. Discuss any plans for alleviating any transmission constraints.

FPL's resource planning work considers two types of transmission limitations/constraints: external limitations and internal limitations. External limitations deal with FPL's ties to its neighboring systems. Internal limitations deal with the flow of electricity within the FPL system.

The external limitations are important since they affect the development of assumptions for the amount of external assistance that is available to the FPL system as well as the amount and price of economy energy purchases. Therefore, these external limitations are incorporated both in the reliability analysis and economic analysis aspects of resource planning. The amount of external assistance which is assumed to be available is based on the projected transfer capability to FPL from outside its system as well as historical levels of available assistance. In the loss of load probability (LOLP) portion of its reliability analyses, FPL models this amount of external assistance as an additional generator within FPL's system which provides capacity in all but the peak load months. The assumed amount and price of economy energy are based on historical values and projections from production costing models.

Internal transmission limitations are addressed by identifying potential geographic locations for potential new generating units that minimize adverse impacts to the flow of electricity within FPL's system. The internal transmission limitations are also addressed by developing the direct costs for siting new units at different locations, by evaluating the cost impacts created by the new unit/unit location combination on the operation of existing units in the FPL system, and/or by evaluating the costs of transmission additions that may be needed to address regional concerns regarding an imbalance between load and generation in a given region. Both of these site- and

system-related transmission costs are developed for each different unit/unit location option or groups of options. In addition, transfer limits for capacity and energy that can be imported into the Southeastern Florida region (Miami-Dade and Broward Counties) of FPL's system are also developed for use in FPL's production costing analyses. (A further discussion of the Southeastern Florida region of FPL's system, and the need to maintain a regional balance between generation and transmission contributions to meet regional load, is found in Chapter III.)

FPL's annual transmission planning work determines transmission additions needed to address limitations and to maintain/enhance system reliability. FPL's planned transmission facilities to interconnect and integrate generating units in FPL's resource plans, including those transmission facilities that must be certified under the Transmission Line Siting Act, are presented in Chapter III.

Discussion Item # 2: Discuss the extent to which the overall economics of the plan were analyzed. Discuss how the plan is determined to be cost-effective. Discuss any changes in the generation expansion plan as a result of sensitivity tests to the base case load forecast.

FPL typically performs economic analyses of competing resource plans using as an economic criterion FPL's levelized system average electric rates (i.e., a Rate Impact Measure or RIM approach). In addition, for analyses in which DSM levels are not changed, FPL uses the equivalent criterion of the cumulative present value of revenue requirements for the FPL system.⁹

The load forecast that is presented in FPL's 2013 Site Plan was developed in February 2013. The only load forecast sensitivities analyzed during 2012/early 2013 were high load forecast sensitivities developed solely to analyze the quality of FPL's future reserves and the projected frequency at which load control might be implemented. These analyses are on-going.

⁹ FPL's basic approach in its resource planning work is to base decisions on a lowest electric rate basis. However, when DSM levels are considered a "given" in the analysis (i.e., when only new generating options are considered), the lowest electric rate basis approach and the lowest system cumulative present value of revenue requirements basis approach, yield identical results in terms of which resource options are more economic. In such cases FPL evaluates resource options on the simpler-to-calculate (but equivalent) lowest cumulative present value system revenue requirements basis.

Discussion Item # 3: Explain and discuss the assumptions used to derive the base case fuel forecast. Explain the extent to which the utility tested the sensitivity of the base case plan to high and low fuel price scenarios. If high and low fuel price sensitivities were performed, explain the changes made to the base case fuel price forecast to generate the sensitivities. If high and low fuel price scenarios were performed as part of the planning process, discuss the resulting changes, if any, in the generation expansion plan under the high and low fuel price scenario. If high and low fuel price sensitivities were not evaluated, describe how the base case plan is tested for sensitivity to varying fuel prices.

The basic assumptions FPL used in deriving its fuel price forecasts are discussed in Chapter III of this document. FPL used three fuel cost, and three environmental compliance cost, forecasts in analyses supporting its 2012 nuclear cost recovery filing.

The high and low fuel cost forecasts are derived from a calculation of the historical volatility of the 12-month forward price for one year ahead. From this range of volatility, a reasonable value from the high end of the range is applied to the medium fuel cost forecast to develop a high fuel cost forecast. Similarly, a reasonable value from the low end of the range is applied to the medium fuel cost forecast to develop a low fuel cost forecast.

The resource plan presented in this Site Plan is based, in part, on those prior analyses. For that reason, this resource plan has not been further tested for different fuel cost forecasts.

Discussion Item # 4: Describe how the sensitivity of the plan was tested with respect to holding the differential between oil/gas and coal constant over the planning horizon.

As described above in the answer to Discussion Item # 3, FPL used up to three fuel cost forecasts in its 2012/early 2013 resource planning analyses. While these forecasts did not represent a constant cost differential between oil/gas and coal, a variety of fuel cost differentials were represented in these forecasts.

Discussion Item # 5: Describe how generating unit performance was modeled in the planning process.

The performance of existing generating units on FPL's system was modeled using current projections for scheduled outages, unplanned outages, capacity output ratings, and heat rate information. Schedule 1 in Chapter I and Schedule 8 in Chapter III present the current and projected capacity output ratings of FPL's existing units. The values used for outages and heat rates are generally consistent with the values FPL has used in planning studies in recent years.

In regard to new unit performance, FPL utilized current projections for the capital costs, fixed and variable operating & maintenance costs, capital replacement costs, construction schedules, heat rates, and capacity ratings for all construction options in its resource planning work. A summary of this information for the new capacity options FPL currently projects to add over the reporting horizon for this document is presented on the Schedule 9 forms in Chapter III.

Discussion Item # 6: Describe and discuss the financial assumptions used in the planning process. Discuss how the sensitivity of the plan was tested with respect to varying financial assumptions.

During much of its 2012 resource planning work, FPL's financial assumptions were: i) a capital structure of 40.88% debt and 59.12% equity; (ii) a 5.50% cost of debt; (iii) a 10.0% return on equity; and (iv) an after-tax discount rate of 7.29%. Starting in late 2012, and continuing in 2013, FPL's financial assumptions have been based on the outcome of FPL's most recent base rate case and include: i) a capital structure of 40.38% debt and 59.62% equity; (ii) a 4.79% cost of debt; (iii) a 10.5% return on equity; and (iv) an after-tax discount rate of 7.45%. No sensitivities of these financial assumptions were used in FPL's 2012/early 2013 resource planning work.

Discussion Item # 7: Describe in detail the electric utility's Integrated Resource Planning process. Discuss whether the optimization was based on revenue requirements, rates, or total resource cost.

FPL's integrated resource planning (IRP) process is described in detail in Chapter III of this document.

The standard basis for comparing the economics of competing resource plans in FPL's basic IRP process is the impact of the plans on FPL's electricity rate levels with the objective generally

being to minimize FPL's projected levelized system average electric rate (i.e., a Rate Impact Measure or RIM approach). As discussed in response to Discussion Item # 2, both the electricity rate perspective and the cumulative present value of system revenue requirement perspective are identical yield identical results in terms of which resource options are more economic when DSM levels are unchanged between competing resource plans. Therefore, in planning work in which DSM levels were unchanged, the equivalent, but simpler-to-calculate, cumulative present value of revenue requirements perspective was utilized.

Discussion Item # 8: Define and discuss the electric utility's generation and transmission reliability criteria.

FPL uses two system reliability criteria in its resource planning work that addresses generation, purchase, and DSM options. One of these is a minimum 20% Summer and Winter reserve margin. The other reliability criterion is a maximum of 0.1 days per year loss-of-load-probability (LOLP). These two reliability criteria are discussed in Chapter III of this document.

In regard to transmission reliability analysis work, FPL has adopted transmission planning criteria that are consistent with the planning criteria established by the Florida Reliability Coordinating Council (FRCC). The FRCC has adopted transmission planning criteria that are consistent with the Reliability Standards established by the North American Electric Reliability Council (NERC). The *NERC Reliability Standards* are available on the internet site (<http://www.nerc.com/>).

In addition, FPL has developed a *Facility Connection Requirements* (FCR) document as well as a *Facility Rating Methodology* document that are also available on the internet under the FPL OATT Documents directory at <https://www.oatioasis.com/FPL/index.html>.

Generally, FPL limits its transmission facilities to 100% of the applicable thermal rating. The normal and contingency voltage criteria for FPL stations are provided below:

<u>Voltage Level (kV)</u>	<u>Normal/Contingency</u>	
	<u>Vmin (p.u.)</u>	<u>Vmax (p.u.)</u>
69, 115, 138	0.95/0.95	1.05/1.07
230	0.95/0.95	1.06/1.07
500	0.95/0.95	1.07/1.09
Turkey Point (*)	1.01/1.01	1.06/1.06
St. Lucie (*)	1.00/1.00	1.06/1.06

(*) Voltage range criteria for FPL's Nuclear Power Plants

There may be isolated cases for which FPL may have determined that it is acceptable to deviate from the general criteria stated above. There are several factors that could influence these criteria, such as the overall number of potential customers that may be impacted, the probability of an outage actually occurring, or transmission system performance, as well as others.

Discussion Item # 9: Discuss how the electric utility verifies the durability of energy savings for its DSM programs.

The projected impacts of FPL's DSM programs on demand and energy consumption are revised periodically. Engineering models, calibrated with current field-metered data, are updated at regular intervals. Participation trends are tracked for all of FPL's DSM programs in order to adjust impacts each year for changes in the mix of efficiency measures being installed by program participants. For its load management programs, FPL conducts periodic tests of the load control equipment to ensure that the equipment is functioning correctly. These tests, plus actual, non-test load management events, also allows FPL to gauge the MW reduction capabilities of its load management programs on an on-going basis.

Discussion Item # 10: Discuss how strategic concerns are incorporated in the planning process.

The Executive Summary and Chapter III provide a discussion of a variety of system concerns/issues that influence FPL's resource planning process. Please see those chapters for a discussion of those concerns/issues.

In addition to these system concerns/issues, there are other strategic factors FPL typically considers when choosing between resource options. These include the following: (1) technology risk; (2) environmental risk, and (3) site feasibility. The consideration of these factors may include both economic and non-economic aspects.

Technology risk is an assessment of the relative maturity of competing technologies. For example, a prototype technology, which has not achieved general commercial acceptance, has a higher risk than a technology in wide use and, therefore, assuming all else equal, is less desirable.

Environmental risk is an assessment of the relative environmental acceptability of different generating technologies and their associated environmental impacts on the FPL system, including environmental compliance costs. Technologies regarded as more acceptable from an environmental perspective for FPL's resource plan are those which minimize environmental impacts for the FPL system as a whole through highly efficient fuel use, state of the art environmental controls, generating technologies that do not utilize fossil fuels (such as nuclear and photovoltaics), etc.

Site feasibility assesses a wide range of economic, regulatory, and environmental factors related to successfully developing and operating the specified technology at the site in question. Projects that are more acceptable have sites with few barriers to successful development.

All of these factors play a part in FPL's planning and decision-making, including its decisions to construct capacity or to purchase power.

Discussion Item # 11: Describe the procurement process the electric utility intends to utilize to acquire the additional supply-side resources identified in the electric utility's ten-year site plan.

As shown in this 2013 Site Plan, FPL's resource plan currently projects the following major supply-side resource additions: the completion of the nuclear uprates project, the modernizations at Cape Canaveral, Riviera, and Port Everglades, the upgrading of CTs in numerous CCs throughout FPL's system, the EcoGen PPA, and Turkey Point Unit 6.

In regard to these capacity additions for which a need determination has already been approved, the nuclear uprates and Turkey Point Unit 6, do not lend themselves to a request for proposal (RFP) approach involving bids from third parties who would build new nuclear generation capacity. In addition, nuclear capacity additions are exempted from the Commission's Bid Rule by section 403.519 (4) (c). For these nuclear projects, FPL's procurement activities are conducted to ensure the best combination of quality and cost for the delivered products. Furthermore, the modernization projects at Cape Canaveral, Riviera, and Port Everglades received Commission waivers from the Bid Rule due to attributes specific to modernization projects (such as use of existing land, water, transmission, etc.) plus other economic benefits to FPL's customers. These waivers from the Bid Rule were granted in Order No. PSC-08-0591-FOF-EI for Cape Canaveral and Riviera and in Order No. PSC-11-0360-PAA-EI for Port Everglades.

CT upgrades are currently taking place at various CC units throughout the FPL system. FPL was approached by the original equipment manufacturer (OEM) of the CTs regarding the possibility of upgrading these units. Following negotiations with the OEM, and economic analyses that showed that upgrading was cost-effective for FPL's customers, the decision was made to proceed with the CT upgrades. That process is underway and is scheduled to be completed in 2015.

The EcoGen PPA was the result of negotiations between EcoGen and FPL.

Identification of self-build options, beyond those units already approved by the FPSC and Governor and Siting Board or units for which FPL may be then seeking approval, in future FPL Site Plans will not be an indication that FPL has pre-judged any capacity solicitation it may conduct. The identification of future generating units is required of FPL in its Site Plan filings and represents those alternatives that appear to be FPL's best, most cost-effective self-build options at the time. FPL reserves the right to refine its planning analyses and to identify other self-build options. Such refined analyses have the potential to yield a variety of self-build options, some of which might not require an RFP. If an RFP is issued for Supply options, FPL reserves the right to choose the best alternative for its customers, even if that option is not an FPL self-build option.

Discussion Item # 12: Provide the transmission construction and upgrade plans for electric utility system lines that must be certified under the Transmission Line Siting Act (403.52 – 403.536, F. S.) during the planning horizon. Also, provide the rationale for any new or upgraded line.

- (1) FPL has identified the need for a new 230 kV transmission line that required certification under the Transmission Line Siting Act which was issued in April 2006. The new line is to be completed in two phases connecting FPL's St. Johns Substation to FPL's Pringle Substation (shown on Table III.E.1 in Chapter III). Phase 1 was completed in May 2009 and consisted of a new line connecting Pringle to a new Pellicer Substation. Phase 2 is planned to connect St. Johns to Pellicer and is scheduled to be completed by December 2017. The construction of this line is necessary to serve existing and future customers in the Flagler and St. Johns areas in a reliable and effective manner.
- (2) FPL has identified the need for a new 230 kV transmission line (by December 2014) that required certification under the Transmission Line Siting Act which was issued on November 2008. The new line will connect FPL's Manatee Substation to FPL's proposed Bob White Substation (also shown on Table III.E.1 in Chapter III). The construction of this

line, scheduled to be completed in 2014, is necessary to serve existing and future customers in the Manatee and Sarasota areas in a reliable and effective manner.

(This page is left intentionally blank.)