

**VERIZON**

**EXPANDED INTERCONNECTION  
SERVICES**

Florida

**SUMMARY & DEVELOPMENT  
OF  
COSTS AND RATES**

**PUBLIC VERSION**

DOCUMENT NUMBER-DATE

01124 FEB-48

FPSC-COMMISSION CLERK

## **VERIZON REDACTION REASONS COLLOCATION COST STUDY**

- 1. The information contained in these files constitutes and is derived from algorithms and/or contractual prices provided to Verizon from third party vendors. Verizon's contractual obligations to those parties include the obligation not to disclose or distribute such proprietary or confidential information. Aside from violating contract terms, disclosure of this information would harm Verizon's future ability to contract for goods and/or services on favorable terms.**
- 2. This information is derived from Verizon employee salary and labor rates. Unilateral disclosure of these rates could adversely affect Verizon's ability to compete for talent in the marketplace.**
- 3. This information contains the detailed cost components underlying discrete basic collocation design and function. Disclosure of such detailed costs for such small pieces of collocation design would give competitors an advantage in designing their networks and in competing against Verizon in the most efficient manner. The fact that Verizon cannot obtain such knowledge about its competitors exacerbates the unfairness of disclosing this detailed cost information.**
- 4. This information contains central office and outside-plant specific data. Disclosure of this information gives competitors an unfair advantage in designing their networks and in competing against Verizon in the most efficient manner. The fact that Verizon cannot obtain such knowledge about its competitors exacerbates the unfairness of disclosing this detailed cost information.**

# Verizon Expanded Interconnection Services

Florida

## Table of Contents

Summary of Rates and Costs	Section 1
Collocation Study Workpapers	Section 2
Common Tables	Section 3

# Verizon Expanded Interconnection Services Summary of Rates and Costs

Florida

## Section 1

### Table of Contents

	Page
Study Overview	1
Summary of Rates and Costs	38
Collocation Drawings	49
Glossary and Acronyms	70

# Verizon Expanded Interconnection Services Cost Study

## Table of Contents

<b>Overview of Cost Study</b> .....	<b>4</b>
Introduction .....	4
Study Results .....	4
Rate Development.....	4
Description of Collocation Types.....	5
Single Cage Collocation .....	5
Shared Collocation.....	5
Sublease Collocation.....	6
Cageless Collocation.....	6
Virtual Collocation.....	6
Adjacent On-Site Collocation .....	6
Microwave Collocation .....	7
Dedicated Transit Service .....	7
Miscellaneous Services .....	7
Common Tables.....	8
Study Structure.....	8
<b>Non-recurring Cost Study Elements</b> .....	<b>9</b>
Introduction .....	9
Engineering .....	9
Regional Implementation Team.....	9
Initial Site Audit.....	9
Project Kickoff Meeting.....	10
Status Meetings .....	10
Building Modification.....	10
Security Access .....	11
Access Card Administration .....	11
Electrical.....	11
Cage Grounding Bar.....	11
Overhead Superstructure.....	11
Cage Enclosure .....	12
DC Power Cable .....	12
Cable Pull.....	12
Fiber Cable Pull .....	12

Metallic Cable Pull .....	14
Cable Splice .....	14
Fiber Cable Splice.....	14
Metallic Cable Splice.....	14
Facility Pull & Terminations.....	15
Relay Rack Installation.....	16
Cabinet Installation.....	16
Virtual Equipment.....	17
Virtual Equipment Installation .....	17
Virtual Software Upgrades.....	18
Virtual Card Installation.....	18
Virtual Equipment Access Request.....	18
<b>Miscellaneous Services .....</b>	<b>19</b>
Engineering/Major Augment Fee (Microwave Only).....	19
Facility Pull (Microwave Only).....	19
BITS Synchronized Timing .....	19
Premise Space Report .....	19
Cable Costs .....	20
Facility Cables.....	20
Power Cables .....	20
Ground Cables.....	20
Fiber Optic Patchcord - 24-Fiber (Connectorized) Cable.....	21
Fiber Optic Patchcord .....	21
Engineering Costs .....	21
Fiber Optic Patchcord Pull.....	21
Fiber Optic Patchcord Termination.....	22
Travel Time .....	22
<b>Monthly Recurring Cost Study Elements .....</b>	<b>23</b>
Introduction .....	23
Floor Space .....	23
Floor Space for Relay Racks.....	25
Floor Space for Cabinet .....	26
Cable Space.....	26
DC Power Facility .....	27
DC Power Utility.....	28
Facility Termination.....	29
Building Modification Costs.....	30
Security Access .....	30
Card Reader .....	30
Site Modification .....	30
Site Preparation.....	30

Dust Partition.....	30
HVAC - Minor (Ventilation Ducts).....	31
Electrical .....	31
Lighting.....	31
Electrical Outlet .....	31
Floor Grounding Bar.....	31
Environmental Conditioning.....	31
Cable Vault Splice Elements .....	31
Fiber Cable Vault Splice .....	31
Metallic Cable Vault Splice.....	32
Cable Vault Space.....	32
Cable Rack Shared Space .....	33
Virtual Frame .....	33
Virtual Maintenance .....	34
Microwave Collocation.....	34
<b>Miscellaneous Services .....</b>	<b>34</b>
BITS Timing.....	34
Fiber Optic Patch Cord .....	35
Chassis, Relay Rack and Floor Space.....	36
Fiber Guide Duct System .....	37
Total Investment .....	37

## Overview of Cost Study

### Introduction

This document describes the process and methodology used to calculate the costs and rates for Single Cage, Shared Cage, Subleased Cage, Cageless, Adjacent On-Site, Virtual, and Microwave Expanded Interconnection Service (EIS) processes for Verizon's central offices. EIS may also be referred to as "collocation." Both of these terms will be used interchangeably throughout this overview. An Alternative Local Exchange Carrier (ALEC) requesting collocation in a Verizon central office will be referred to as a collocator.

A team of Verizon cost personnel collaborated with a variety of Subject Matter Experts (SME) within Verizon to develop this study. It conforms with the provisions adopted by the Federal Communications Commission (FCC).

### Study Results

The results of the collocation cost study represent the forward-looking costs Verizon expects to incur to provision collocation to ALECs. The Rate and Cost Summary results are found at the end of this section (Section 1). The summaries depict the non-recurring and monthly recurring costs and rates for collocation.

### Rate Development

The first step in rate development is mapping each cost element to a relevant rate element. The total cost for each rate element is equal to the sum of its constituent cost elements. For example, the Overhead Superstructure rate is comprised of multiple cost elements including cable racking (dedicated) - engineering, which in turn is comprised of engineering costs and travel time. Combining multiple cost elements into a smaller number of rate elements greatly simplifies the rate structure and eases the ordering and administrative functions of collocation.

In the second step of the rate development process, the number of units and their frequency (or the percentage of time that cost element units will be required) are developed and applied to the costs. This results in a reflection of the average usage associated with a particular rate element. For example, the Engineering/ Augment Fee is developed by weighting the new collocation site fee by 29% and the existing collocation site fee by 71% to reflect the distribution of occurrences of that rate element Verizon expects going forward.



In the third step, if multiple collocators share a rate element, an occupancy rate is developed to divide the cost between all users. The occupancy rate is based on the average number of collocators in Verizon's central offices with collocation activity. Currently, an average of four collocators occupy Verizon's central offices.

The occupancy rate is applied to share the costs of some Building Modification cost elements, Environmental Conditioning and the Premise Space Report.

As shown in the pricing details, four collocators are used to spread the costs for Storage Security, Demolition and Site Work, and Floor Grounding Bar cost elements. Five users are used to spread the cost for the Security Access - Card Reader & Controller cost element. Verizon included itself as the fifth user of this service.

Verizon's proposed NRC rates equal the proposed costs; no additional common costs are added. The proposed MRC rates include a mark-up of the original cost as a contribution for the recovery of Verizon's common costs.

### **Description of Collocation Types**

Verizon EIS addresses eight types of collocation: Single Cage, Shared Cage, Subleased Cage, Cageless, Adjacent On-Site, Virtual, Microwave and Dedicated Transit Service. (Refer to Collocation Drawing No. 1 for a schematic of the various offerings.)

#### ***Single Cage Collocation***

Single Cage collocation provides the ALEC with dedicated caged floor space. This enables one collocator to locate their transmission equipment in a segregated, secured area of Verizon's central office. The collocator has direct access to the collocation cage to install, maintain, and repair its equipment.

#### ***Shared Collocation***

A shared collocation arrangement is a caged collocation space shared by two or more ALECs. One of the collocators is considered the Host collocator (HC) and every other collocator sharing the same area is referred to as a Guest collocator (GC). The Host collocator is responsible for ordering and paying for all shared cage services requested from Verizon. The HC is also responsible for the collection and remittance of payments to Verizon from the GCs for all activity

that takes place within the shared cage area. Each collocator establishes a separate Line Service Request (LSR) account with Verizon for requesting UNEs.

### *Sublease Collocation*

Sublease collocation occurs when an existing collocator determines that it has surplus space in its contracted cage space and chooses to lease the excess space to another ALEC. Verizon must be notified prior to a contract agreement in order to permit the contracting collocator to sublease the surplus space to a third party guest collocator. The host collocator subleases the floor space to the Guest collocator pursuant to terms and conditions agreed to by the two parties.

### *Cageless Collocation*

Cageless collocation is an arrangement in "whole equipment bay/cabinet" increments, utilizing a non-partitioned area in a Verizon central office. The ALEC has direct access to the collocation area in order to install, maintain, and repair its equipment. One or more collocators may jointly occupy the cageless collocation area.

### *Virtual Collocation*

Virtual collocation differs from caged or cageless collocation in that no separate collocation space is established in the Verizon central office. Instead, Verizon leases the equipment from the collocator for a nominal amount and installs, repairs, and maintains the collocator's equipment and cable facilities at Verizon's central office. The collocator's facilities are connected to Verizon's network. The Virtual collocation equipment is provided by the collocator and is dedicated to its exclusive use. However, the collocator does not have access to this equipment.

### *Adjacent On-Site Collocation*

Adjacent On-Site collocation is available only when physical collocation space in a Verizon central office is exhausted. The collocator constructs a separate building on Verizon's property. The ALEC installs, repairs and, maintains its equipment in the separate building. ALEC access to the Verizon central office is not necessary. All of the collocator's equipment is located and interconnected to Verizon's central office within the adjacent building. (Refer to Collocation Drawing No. 19 for additional details.)

### *Microwave Collocation*

Verizon requires that ALECs requesting the installation of microwave equipment have a physical or virtual collocation arrangement in Verizon's central office prior to the installation of microwave equipment. If the ALEC requesting microwave collocation does not have an existing collocation arrangement, one must be requested using Verizon's physical or virtual collocation tariff or the ALEC's interconnection agreement before microwave equipment can be installed.

Verizon offers two elements on an individual case basis (ICB): (1) Building Penetration for Microwave Cable to penetrate buildings for microwave cable routing and (2) Special Work for Microwave for the installation of ALEC's microwave collocation equipment that are not recovered via other microwave rate elements.

### *Dedicated Transit Service*

Dedicated Transit Service (DTS) allows a collocator to interconnect its network and collocated equipment with that of another collocator within the same Central Office. DTS is provided between the collocated arrangements of the same collocated customer or of two different collocated customers. It is available at the DS0, DS1, and DS3 electrical transmission level or via dark fiber.

DTS is ordered through an Access Service Request (ASR) and is provisioned through the same processes as the Wholesale UNE products

### **Miscellaneous Services**

Miscellaneous Services are activities that are included in Verizon's collocation cost study and may have applications associated with any collocation activity or stand-alone service. Miscellaneous Services include:

- BITS Timing;
- Premise Space Report;
- Facility and Power Cable; and
- Fiber Optic Patchcord.

## **Common Tables**

The common tables are used in calculations for various work sheets in the cost study. The tables include:

- Central Office Equipment Installer (COEI) Time Study also referred to as Hours Per Unit (HPU) Study;
- Material Loadings;
- Annual Cost Factors;
- Single Source Provider Rates; and
- Loaded Labor Rates; and
- Engineered Furnished and Installed Factors.

## **Study Structure**

The Verizon cost and rate study is structured as follows:

- Section 1 - Summary of Rates and Costs;
- Section 2 - Workpapers; and
- Section 3 - Common Tables.

Where appropriate, each section is formatted by grouping cost elements by non-recurring and recurring costs.

## **Non-recurring Cost Study Elements**

### **Introduction**

This section of the study explains the development of non-recurring collocation costs of Verizon's operations. Costs are based on collocation provisioning standards currently being used by Verizon and the most recent collocation data available. The relevant cost elements and the methodologies are described below:

### **Engineering**

Engineering costs include time spent by Verizon personnel planning and engineering a specific collocator's project. Various engineering personnel including the Central Office (CO) Equipment Engineer, Outside Plant (OSP) Engineer and Land and Building Engineer are involved in this process. The costs for the CO Equipment Engineer and OSP Engineer include the time spent on the initial site audit, the project kickoff meeting, and project status meetings. The cost for the Land and Building Engineer includes all of the time required by the engineer to complete the entire project.

Additional CO Equipment Engineering and OSP Engineering time incurred during a specific collocation activity are captured in that specific cost element.

### **Regional Implementation Team**

Brief descriptions of the Regional Implementation Team (RIT) meetings scheduled during a collocation project are provided below:

#### ***Initial Site Audit***

Once a collocator submits an application for collocation, Verizon performs an Initial Site Audit. If the ALEC requests physical collocation, the purpose of the initial walkthrough is to determine the answers to the following questions, among others:

1. What are Verizon's future needs for this office?
2. Is there sufficient space for physical collocation?
3. If sufficient space is available, where is the best location for the collocation area?
4. What building modifications are necessary to provide collocation?

5. Do sufficient DC power facilities exist in the central office to accommodate the collocation request?

If the application indicates a request for virtual collocation, the CO Equipment Engineer visits the site to determine if there is sufficient space for virtual collocation and where the virtual arrangements should be placed.

### *Project Kickoff Meeting*

The project officially begins once Verizon receives one-half of the non-recurring costs of the project from the collocator. Verizon then discusses and coordinates deadlines for completing the project with internal Verizon employees and outside contractors.

### *Status Meetings*

Once the work in the central office has begun, the parties meet for a status meeting. The purpose of the status meeting is to resolve any issues or problems identified on the project. There will always be at least one status meeting per project. Additional status meetings will be scheduled as necessary and appropriate. The amount of interaction between the parties involved will impact the number of status meetings held.

### **Building Modification**

The physical building modification cost element is designed to include all costs associated with modifying the central office to accommodate a collocator. There may be up to two external contractors, an engineering firm and a general contractor, involved in this process.

The engineering firm's purpose is twofold. First, the engineer is responsible for identifying, at a high level, the building modifications necessary to accommodate the collocator. Second, the engineer works with an architect to create blueprints that detail the construction required in the collocation area. The general contractor uses these drawings to plan the actual construction and identify the necessary subcontractors.

The general contractor is responsible for completing the construction for the building modification portion of the project. This includes hiring and coordinating all necessary subcontractors.

Due to the variability of the collocation projects, there are several building modification cost elements presented in this study. Each cost element described is the average cost incurred when the underlying work is completed for a project.

Each cost element is calculated based on prior collocation projects completed in California and Texas. The cost estimates developed from the California and Texas projects are adjusted to a national average using the National Construction Estimator. The national averages are converted to state-specific costs using the National Construction Estimator.

The building modification cost elements are described as follows:

### **Security Access**

#### ***Access Card Administration***

This element is an administrative cost associated with providing access cards to collocators to gain access to Verizon central offices and includes the time spent for ordering, assignment, filing, programming, distribution, replacing, and changing access cards.

### **Electrical**

#### ***Cage Grounding Bar***

A cage grounding bar will be placed inside the collocator's cage. It is an extension from the floor grounding bar. The cost includes the materials and labor associated with placing the cable and cage grounding bar in the caged area. (Refer to Collocation Drawing Nos. 4 and 5 for additional details.)

#### **Overhead Superstructure**

Overhead superstructure is required to extend the existing cable racking system in the central office to the collocation area and to a specific collocator's site. The costs include all engineering, labor, and materials costs required to install the system in a Verizon central office. Due to the variability of cable racking from one project to another, the cost is calculated in one-foot increments using the typically utilized 24-inch cable racking.

The engineer's cost includes time for drafting the work order, determining what is needed to provide the racking, ordering all equipment, updating the records, and closing the work order once the job is completed. The Central Office

Equipment Installer's loaded labor rate is based on the COEI's hours per unit time to install cable racking. (Refer to Collocation Drawing Nos. 8 and 9 for additional details.)

### **Cage Enclosure**

This element includes the vendor's cage fencing and gate labor and materials costs incurred to construct the collocator's cage. There are five cage enclosure rate elements based on the size of the cage: 1) 25 to 100 square feet; 2) 101 to 200 square feet; 3) 201 to 300 square feet; 4) 301 to 400; and 5) 401 to 500 square feet.

### **DC Power Cable**

This cost includes the pulling of the power cable from the Battery Distribution Fuse Bay (BDFB) to the collocator's specific location. The collocator may purchase the power cable from Verizon or provide the cable for Verizon to install. Separate power cable rates are available if the cable is purchased from Verizon.

In order to terminate the power cable, a connector tap must be placed on each end of the cable. The termination cost includes the cost of the connector tap and the time to place the tap. The placement of the tap is based on the Central Office Equipment Installer's HPU's. The source of the connector tap cost is found in Verizon's materials records (GTEAMS), which reflect invoiced costs for inventoried items and current price quotes from third party vendors.

The engineering time associated with the provisioning of power is based on Verizon's experience. This activity includes checking power requirements for available power, drafting a work order, ordering equipment and materials, updating records, and closing the work order once the work activity has been completed. One hour of travel time for the COE Installer is included in this cost element. (Refer to Collocation Drawing No. 2 for additional details.)

### **Cable Pull**

#### ***Fiber Cable Pull***

The fiber cable pull cost includes four (4) cost elements:

1. Engineering the cable pull;
2. Placing innerduct within the Verizon CO;
3. Pulling the cable; and
4. Cable Fire Retardant.



The engineering cost for the cable pull element includes the time spent by the Outside Plant Engineer to complete the project. The engineer is responsible for checking and assigning facilities, writing and issuing a work order, directing the work activity, recording updates, processing invoices, and closing the work order at the end of the project.

The cost element for placing innerduct includes the cost to run the innerduct, in which the fiber cable is placed, from the cable vault to the collocator's arrangement. This cost is developed based on Verizon's internal CO Equipment Installer's labor rate and the activity time required to perform the task.

The cost element for pulling the cable captures the cost of pulling the collocator's fiber cable into Verizon's CO vault and through the innerduct to the collocator's area. The rate is based on each foot of cable pulled. In a collocation arrangement, it is the collocator's responsibility to run its cable from its network to the first manhole outside the designated Verizon central office. It is also the collocator's responsibility to provide additional cable for the distance between the manhole and the collocator's cage. Verizon will pull the cable from the manhole to the collocator's cage inside the central office. If there is no manhole outside of the central office, Verizon will determine a point to which the collocator will need to provide the cable to. Verizon will be responsible for pulling the cable from that point to the collocator's cage.

The time estimates for pulling cable are based on Verizon's Single Source Provider (SSP) rates. Because it is the collocator's responsibility to provide the cable, the cost represents only the labor to pull the cable, the innerduct cost, and the placement of the cable. (Refer to the Collocation Drawing No. 11 for additional details.)

Cable fire retardant activity is associated with filling the space around cables with non-flammable material. This activity is required when DC power cable or transmission cable is run between floors or through a wall. The retardant prevents fire from spreading from one room or floor to another. The CO Equipment Installers must first remove the existing cable fire retardant. Once the cable has been pulled through the wall or between floors, the cable fire retardant material must be placed back in and over the hole. The number of hours assigned to perform this task does not vary, regardless of the type of cable or where the hole is drilled.

The cost for cable fire retardant is calculated on the average number of hours required by CO Equipment Installers to secure the holes between rooms with fire

retardant material. This amount is multiplied by the loaded labor rate of the CO Equipment Installers. The labor rates are Verizon's Loaded Labor Rates for the state this cost study represents. (Refer to Collocation Drawing No. 8 for additional details.)

### ***Metallic Cable Pull***

The metallic cable pull applies only to adjacent collocation. The cost is incurred for provisioning the facilities from the cable vault, out of the central office, and into the adjacent building. The collocator will provide sufficient cable into the cable vault where a splice will be made to connect it to Verizon's central office cable. The central office cable (stub) is connected to a protector that will be mounted to the vertical side of the frame. This is required to provide protection to the central office from stray voltage that may be induced on metallic cable.

The pull costs are based on SSP rates for the cable pull and are available in two cable sizes. The rates are based on the diameter size of the cable-- less than or greater than 1.5 inches in diameter.

The Outside Plant Engineer costs include activities to engineer the pull, assign the conduits, estimate lengths, order material, write a work order, arrange for the pull, update records, and close the work order upon completion of the project.

Separate cable fire retardant activities will be required if the cables pass through floors or walls within the central office. (Refer to Collocation Drawing No. 12 for additional details.)

### **Cable Splice**

#### ***Fiber Cable Splice***

This element is applied if the collocator requests Verizon to splice the fiber cable pulled into the central office. The splice may take place in the cable vault or in the collocator's cage. The costs are based on the SSP rates for splicing fiber cable only. (Refer to Collocation Drawing No. 11 for additional details.)

#### ***Metallic Cable Splice***

This cost is applied if the collocator requests Verizon to splice cable. The rate is based on the SSP rates for each state.

Metallic Cable splicing is based on the number of pairs in the cable that require splicing. Two options are available--200 pair or less and greater than 200 pair. The rate is offered on a per pair basis.

When metallic cable is introduced into the central office, it must be connected to a protector that is mounted on the vertical side of the main distribution frame. Cables from the protector (stub) are extended to the cable vault and are spliced to the outside plant cable.

This labor element recovers the cost for an Outside Plant Engineer to engineer the splicing of the cable and includes writing a work order, providing instructions for the splicing, and updating the records. (Refer to Collocation Drawing No. 12 for additional details.)

#### **Facility Pull & Terminations**

A Facility Pull includes the labor cost of running the interconnection wire from the collocation cage to the block or panel. A separate termination cost is developed for each type of cable: DS0, DS1, or DS3. (Refer to Collocation Drawings No. 1, No. 11 and No. 12 for additional details.)

The length of the wire pull varies among central offices based on the relative proximity of the collocation cage to Verizon's point of termination and the type of interconnection (DS0, DS1, or DS3) requested by the collocater. Verizon's activity-based time estimates are used to determine the time involved in pulling and terminating these cables. Cables supplied by the collocater must be pre-assembled, connectorized cables. (Refer to Collocation Drawing No. 13 for additional details.)

If Verizon must place a connector on the coaxial cable (DS3), the termination cost is greatly increased. The labor time for pulling the lines are obtained from the CO Equipment Installation HPU listing. The cost of pulling each type of cable is provided in one-foot increments.

The final labor component of the facility pull is the engineering cost of the facility cable pull. The consolidated engineering cost is based on the average number of hours required by Verizon central office engineers to develop all facility pulls, draw the plans, write the work orders, order any necessary equipment, perform record updates, and close the work order once the project is completed.

All installation and engineering hours are multiplied by the corresponding loaded labor rate. Verizon's actual labor and overhead costs are the source of the labor rates used.

### **Relay Rack Installation**

A collocator may purchase the relay rack, engineering, and installation from Verizon. The relay rack costs are derived from Verizon's GTEAMS system and includes the costs of any miscellaneous hardware. The engineering costs for the placement of the relay rack is an engineering SME estimate from the Network Design group responsible for engineering this type of equipment. The source of the installation time is found in the COEI HPU table. One hour of travel time is included for the installer. (Refer to Collocation Drawing No. 6 for additional details.)

Additionally, a 10-position fuse panel is available and may be installed in the relay rack on request.

All installation and engineering hours are multiplied by the corresponding loaded labor rate. Verizon's actual labor and overhead costs are the source of labor rates.

### **Cabinet Installation**

Cabinet installation is available on request. Verizon will provide an equipment cabinet as well as the engineering and installation of the cabinet. The telecommunications cabinet is the standard cabinet used by Verizon and the cost is from GTEAMS. Materials loadings are also applied to develop the total materials cost.

Engineering costs are provided by SMEs responsible for engineering this type of equipment. The installation hours used are Verizon's own central office Equipment Installer's time needed to install this type of equipment. The installer's time includes the hours spent to inventory the required equipment, read the engineered prints, and install the cabinet per Verizon's practices for cabinet placement. Two employees are required to assure a safe and proper installation. The cabinet is a bulky item and must be placed in an exact spot. Two hours of travel time (one hour per employee) are included for this activity.

All installation and engineering hours are multiplied by the corresponding loaded labor rate. Verizon's actual labor and overhead costs are the source of the labor rates.

### **Virtual Equipment**

In a virtual collocation arrangement, the collocator provides the equipment and Verizon personnel install it in the central office. This study develops three non-recurring costs, which are specific to the Virtual Collocation arrangement:

- Virtual Equipment Engineering and Installation;
- Virtual Software Upgrades; and
- Virtual Card Installation.

### ***Virtual Equipment Installation***

This cost element includes the time incurred by Central Office Equipment Installers to install the collocator's equipment and the CO Equipment Engineer's time spent engineering the project. If the collocator's equipment is not Verizon standard, the collocator will be responsible for training Verizon's central office personnel in the operation of their equipment. The training costs will be recovered as an ICB.

There are several equipment engineering and installation cost elements, depending on the type of equipment the collocator provides to Verizon. The two basic components are engineering and installation, as described below:

The Central Office Equipment Engineer is responsible for the technical planning and engineering of the ALEC order. The engineer must understand the type of equipment the collocator provides Verizon in order to install it properly and determine if any special issues arise (e.g., whether it is necessary for the collocator to provide equipment training for the installers). The Central Office Equipment Engineer must also identify and resolve any issues associated with interconnecting the virtual equipment to Verizon's power facilities and network. Finally, it is the engineer's responsibility to identify and order any minor materials needed to install the equipment.

The CO Equipment Installer is responsible for the actual placement of the equipment in Verizon's central office. First, the installer must inventory the equipment and materials to ensure that tools and materials needed to install the equipment are available. Once the materials are inventoried, the equipment must be mounted in the relay rack. After mounting, the CO Equipment Installer

connects the signal cables to the back of the unit and installs the cards inside the unit. The cost of card installation includes placing the cards in the relay rack and configuring the card software. After the equipment is completely installed and the DC power and signal cables have been run (separate cost elements in the study), the technician will test the collocator's equipment to make sure it is working properly.

A weighted average cost per quarter rack is calculated based on:

- The frequency of each type of equipment collocated; and
- The average number of base units that can fit into a standard Verizon relay rack.

### *Virtual Software Upgrades*

Upon a collocator's request, Verizon will install software upgrades on virtually collocated equipment. The virtual software update cost element includes the time incurred by the CO Equipment Installer to install software upgrades on a per upgrade, per base unit basis. A weighted average cost per software upgrade, per base unit is calculated based on the frequency of each type of equipment collocated.

### *Virtual Card Installation*

A collocator may request the installation or replacement of a card within a base unit. The virtual module engineering and installation cost element includes the time the central office Equipment Engineer spends engineering the installation and the CO Equipment Installers spend installing the card. Engineering time includes such tasks as:

- Determining the location of the base unit where the card is to be installed;
- Determining the appropriate cables, cable lengths and connections;
- Ordering materials required; and
- Creating and closing the work order.

A weighted average cost per card installed is calculated based on the frequency of each type of equipment collocated.

### *Virtual Equipment Access Request*

A collocator may submit a Virtual Equipment Access Request. Verizon will allow an approved contractor to access the specified Central Offices to manually

inventory the collocators' equipment. If the collocator requires identifying relay rack/bay numbers to direct the contractor to the proper relay racks/bays, Verizon will provide this information for a separate charge.

## **Miscellaneous Services**

### ***Engineering/Major Augment Fee (Microwave Only)***

The Engineering/Major Augment Fee (Microwave Only) applies when an existing Caged and Cageless collocation arrangement is augmented with newly installed microwave antennae and other exterior facilities. This charge recovers the costs of the initial walkthrough to determine if there is sufficient space for the project, where the microwave antennae and other exterior facilities would best be located, what building modifications are necessary, if any, and if sufficient support facilities exist on the premises to accommodate the microwave antennae and other exterior facilities. This fee also includes the total time for the Building Services Engineer to coordinate the entire project.

### ***Facility Pull (Microwave Only)***

The Facility Pull (Microwave Only) element is applied per linear foot and recovers the labor cost of pulling transmission cable from the microwave antennae and other exterior facilities on the rooftop to the transmission equipment in the collocation cage or relay rack.

### **BITS Synchronized Timing**

The non-recurring costs associated with the installation of an access port are based on the time and material required to place shielded cable from the port to the collocator's equipment. Labor time is based on the Central Office Equipment Installer's Hours per Unit and the loaded labor rate for that installer. The engineering costs are based on the engineer's time to make port equipment assignments, create a work order, and update the records when the work order has been completed.

### **Premise Space Report**

At the request of a collocator, Verizon will perform an analysis for caged or cageless types of collocation for a specific central office. The detailed report will provide the requesting collocator with the available collocation space within the specific central office. It also includes information on the existing occupied space

and future requirements for space within the central office. The premise space report fee is assessed on a per request, per central office basis. This report is not required prior to the submission of a collocation application.

### **Cable Costs**

GTEAMS is the source of costs for facility, power and ground cables. Materials loadings, which include freight, sales tax, and supply provisioning, are also included in the cable costs. (Refer to Collocation Drawing No. 18 for additional details.)

#### ***Facility Cables***

The facility cable cost is applied when an ALEC elects to purchase cables from Verizon rather than providing its own cables. Facility cables are connectorized cables used for plugging into the terminal connecting equipment or blocks. The cables are specific in length and pair size.

The cost for DS3 coaxial cable is based on the GTEAMS cost per linear foot and the materials loadings applied.

The cost for shielded cable (orange jacket) is based on GTEAMS cost per linear foot and materials loadings. Shielded cable is used when a shield is required to eliminate interference on the cables. This type of cable is used when a BITS port is requested.

#### ***Power Cables***

Power cables are flexible power wire cables that are used in the provisioning of power from the Battery Distribution Fuse Bay to the collocator's individual cage, relay rack, or cabinet location. The cost per linear foot is found in GTEAMS, with the appropriate loadings applied. Power cables are also used, in certain applications, as a ground cable. (Refer to Collocation Drawing No. 18 for additional details.)

#### ***Ground Cables***

A ground cable is a #6 American Wire Gauge (AWG) ground wire (cageless application) that is used in the grounding of the relay rack or cabinet to the floor ground bar. The source of the cost per linear foot is the GTEAMS database. Appropriate materials loadings are applied.



### ***Fiber Optic Patchcord – 24-Fiber (Connectorized) Cable***

The materials cost per linear foot of the fiber optic patch cord cable includes twenty-four fibers per patch cord. Each of the twenty-four fibers has a fiber connector on each end. GTEAMS is the source of the materials cost.

The collocator is responsible for providing the Fiber Optic Patch Cord, in the appropriate length, from the collocator's equipment to Verizon's collocator-designated fiber distribution panel. The collocator has the option of purchasing the fiber patch cord from Verizon.

### **Fiber Optic Patchcord**

The Fiber Optic Patchcord is available to collocated customers who require fiber access to unbundled network elements. The collocation cost study includes the development of the associated non-recurring costs for the fiber optic patch cord between the collocator's cage, cageless, or virtual arrangement and Verizon's collocator-designated fiber distribution panel. (Refer to Collocation Drawing No. 20 for additional details.)

The following costs are developed:

- Labor to place the fiber optic patch cord in a fiber duct system from the physical or virtual collocation arrangement to Verizon's designated collocation fiber distribution panel; and
- Labor to terminate the fiber optic patch cord at Verizon's collocator designated fiber distribution panel.

### ***Engineering Costs***

This element represents the cost to engineer the facility termination. The source of the loaded labor rates is the Loaded Labor Rate Tables provided by the Verizon finance group. Hours required to perform the task are SME estimates. The cost calculation is total hours multiplied by the appropriate loaded labor rates.

### ***Fiber Optic Patchcord Pull***

This element identifies the cost of the labor to pull the fiber optic patchcord from the collocation cage or the cageless arrangement to Verizon's collocator

designated fiber distribution panel. The cost is developed on a cost per linear foot basis and includes the COEI HPU.

***Fiber Optic Patchcord Termination***

The termination of the patch cord is the connection of the patchcord to the fiber distribution panel. The time to perform this activity is based on the COEI HPU.

***Travel Time***

Travel time is the time required for a Central Office Equipment Installer to travel to the central office to perform activities requested by the collocater. The travel time is one hour and based on the COEI HPU.

## Monthly Recurring Cost Study Elements

### Introduction

This section describes Verizon's collocation process and the cost methodologies used to develop monthly recurring costs. The summary of these costs is found in Section 1. The workpapers are found in Section 2.

Verizon personnel documented the processes based on observations and interviews with Verizon subject matter experts. Consistent with the long-run time horizon of the study, the cost development of these processes has been adjusted to reflect any known and measurable changes in Verizon's collocation policies or changes in technology.

The cost elements and the cost methodologies are described below. The cost elements may be applied to any of the seven types of collocation: Single Cage, Shared Cage, Sublease Cage, Cageless, Virtual, Microwave, and Adjacent On-Site. (Refer to Collocation Drawing No. 1 for additional details.)

### Floor Space

The cost to provide environmentally conditioned floor space is based on the average cost per square foot of the central offices included in the study. It includes an amount for shared square feet for the common areas of the central office. Environmentally conditioned space has the proper humidity and temperature controls to house telecommunications equipment. Only costs that relate directly to land and building space are included in the cost studies.

Floor space cost is determined by examining the building investment, square footage, and monthly maintenance/utility expenses of a selected sample of central offices. The Verizon central offices examined are varied by technology and size. Land costs are based on their original investment value.

The selected central offices are used to calculate an average cost per square foot. Each central office is examined with reference to the original building investment, relative to the date of investment. Other incremental investments incurred to date are also analyzed. The investment data are obtained from Verizon's Property Operation's Asset Management Property System (AMPS) database. The original investments are calculated to their present values using the R.S. Means Index Factor. This index is used to convert national average building costs in the past to an approximate building cost in today's dollars. The

total building investment's present value for each central office is divided by the total square footage of the central office to determine the square foot investment. Original land investment costs are used for the same central offices because a present value of land index is not available. Land values are calculated on a square foot basis and added to the square foot building values.

In order to annualize the investment for each central office, the land and building investment amounts are multiplied by the land and building's annual cost factors (ACF). The factors are obtained from Verizon Finance department's calculations. The building investment is adjusted for major Heating, Ventilation and Air Conditioning (HVAC) costs associated with providing HVAC for the building shell. HVAC costs associated with maintaining the appropriate environment for telecommunications equipment are included as a separate cost element "Environmental Conditioning."

The source of the monthly maintenance and utility expenses for each central office is the year-end expense reports obtained from the File Manager Database. The compiled reports summarize expenses in the following categories: Building Maintenance, Recurring Contract Services, Janitorial, and Utilities. The electric expense portion of the Utility Expense is excluded because this cost is calculated separately in the DC Power Utility cost element. The maintenance and remaining utility expenses are combined to arrive at a total maintenance and utility expense for each central office. The expenses are divided by the square footage of the central office to develop the monthly maintenance and utility cost per square foot.

The monthly recurring cost for floor space, per central office is determined by combining the annualized investment cost per square foot and the maintenance and utility expense per square foot for each central office, averaging the annual cost of the central offices, and dividing by twelve (months per year).

The cost per square foot of each of the central offices is analyzed in order to exclude any outlier costs. The mean and standard deviation of the costs are calculated and any cost per square foot that falls outside two standard deviations from the mean are excluded as outliers. Finally, the average cost is calculated (excluding the outliers).

In this study, the average cost per square foot for floor space is used to develop the costs for collocation that require floor space.

A shared access cost is added to the cost per square foot for the use of hallways, rest rooms, break rooms, and staging areas, if appropriate. The shared access area is calculated using actual building prints for sixteen central offices from various Verizon states. The following steps are used to calculate the shared access cost:

Step 1. Estimates of the square footage for the hallway, rest room, break room, and staging area in each of the sixteen central offices are totaled together to calculate the shared access area;

Step 2. The shared access area is divided by the total square footage of the sixteen buildings to calculate a shared access percentage;

Step 3. The shared access percentage is multiplied by the cost per square foot of the central office floor space resulting in a square foot cost for the shared access area;

Step 4. The square foot cost of the shared access area is added to the cost per square foot of the central office floor space resulting in an annual cost per square foot of floor space; and

Step 5. The annual cost per square foot of floor space is divided by twelve to calculate the cost per square foot, per month.

Shared access space is available for all collocators and Verizon personnel to gain access to central office equipment.

### **Floor Space for Relay Racks**

In cageless collocation, the square footage needed for the placement of the relay rack is calculated as follows: The standard rack is 24 15/16 inches wide with 15 inch guard rails on each side. The space in front and in back of the relay rack must be kept open in order to access equipment placed in the rack. The aisles are estimated to be 36 inches wide. Thus, the width of the aisles both in front of and behind the relay rack is 18 inches. The depth of the space is estimated to be:

- 15 inches for the equipment (guard rail to guard rail);
- 18 inches in the front of the rack for aisle space; and
- 18 inches in the rear of the rack for aisle space.

The total is fifty-one (51) inches in depth. The width of the rack is 24 15/16 inches.

These dimensions are used to determine the total square footage occupied by a relay rack. The total is divided by the width footage of the relay rack to provide a square footage per linear foot. Collocators are able to request space on a linear foot basis based on the number and size of the relay racks installed. (Refer to Collocation Drawing No. 6 for additional details.)

### **Floor Space for Cabinet**

For cageless collocation, the collocator may choose to place a telecommunications cabinet in the collocation area to house its telecommunications equipment. Verizon personnel used the standard sized cabinet their own equipment is housed in to estimate the floor space for the cabinet. The dimensions of the cabinet are 29 inches by 33 inches. An aisle must be available in the front and rear of the cabinet, as a passageway and work area. The normal width of an aisle is 36 inches. Again, technicians may work on either side of the aisle, so the aisle width is divided by two.

The following dimensions are used in the calculation of floor space for the cabinet:

- 29 inch width;
- 33 inch depth;
- 18 inches for the front aisle; and
- 18 inches for the rear aisle.

The square footage is translated to a linear foot basis. The collocator may request linear footage based on the size or number of cabinets it places in the cageless collocation area. If the cabinet requires side ventilation, the floor space can be adjusted to accommodate the additional linear footage needed. (Refer to Collocation Drawing No. 7 for additional details.)

### **Cable Space**

Cable space is the materials cost that accounts for the occupation of the cable within the manhole/conduit system. All materials costs are obtained from the GTEAMS database used to generate actual costs. Labor costs are calculated by multiplying time estimates from the Broadgauge unit's file by the appropriate Verizon loaded labor rate. Rates from the SSP file are used in determining the costs associated with activities that vendors may provide. The overall cost is determined by calculating the manhole, conduit materials and installation costs for the cable space. The manhole materials costs are calculated from the original

cost of a manhole, calculated as a cost per conduit and a cost per subduct. This calculation estimates three (3) subducts per conduit.

Manhole installation costs are calculated using the average time and labor rate required to install the manhole. Also included are the costs per conduit, per subduct labor, and per core drilling, resulting in the total manhole installation cost per conduit and per subduct.

The conduit material cost is calculated on a cost per foot, per duct basis. The total cost is calculated on a per subduct basis. The distance from the manhole to the central office can differ greatly between central offices. Therefore, the materials cost for the conduit and subduct is based on a cost per foot.

Conduit installation costs are determined by including the costs for trenching, concrete, and restoration costs per conduit, on a per foot basis. These costs are obtained from current SSP rates for each state. A typical installation of conduit is used to generate this cost and is calculated on a per subduct basis.

A materials loading factor is applied to the cable space materials cost in order to account for other relevant costs. The source of the factor is Verizon's Fact Finder System. Materials loading factors include costs for sales tax, supply provisioning, and other minor materials costs. The materials loadings are added to the cable space materials and labor costs to arrive at a total cable space cost. The Annual Cost Factor (ACF) is applied to the total cost in order to calculate the annual recurring cost for cable space. The annual recurring cost is divided by twelve to calculate the monthly cost. (Refer to Collocation Drawing Nos. 11 and No. 12 for additional details.)

#### **DC Power Facility**

DC Power Facility is the materials and installation cost to provide DC power to the collocator's area. Costs include power cable to extend power from the power plant to the collocator's area, fuse panels, relay racks, distribution bays, and a portion of the existing power plant. The power plant consists of batteries, rectifiers, main fuse panels, electrical connections, and backup generators to the main power source.

Central office power plant costs are calculated using current estimates for power plant equipment investments for CO base units by line size multiplied by the power installation factor. The individual state exchanges are identified by line size and used as weighted percentages to the line size in the power plant

calculation. This calculation is used to determine the cost of the equipment and labor on a per amp basis. The rate is specific to each state.

Power Cable refers to the cable that is needed to extend power from the main power distribution panel to a battery distribution fuse bay in the collocation area. (Refer to Collocation Drawing No. 2 and No. 3 for additional details.)

The cost of pulling the power cable is based on the central office equipment investment, multiplied by the power installation factor, and an estimated footage of 125 feet. Cost of the connector taps and a 750-mcm power cable are found in Verizon's GTEAMS system and are used to calculate the power cable costs. Each cable requires a connector tap on each end for termination. These costs are divided by the engineering capacity of the BDFB that the power cable feeds (480 amps).

The cost of a battery distribution fuse bay is based on a RELTEC model 1293B2 equipped for 600 amps. The cost includes the relay rack, common equipment, metering panels, and fuse panels. This model is provisioned for both "A" and "B" power feeds. The costs are calculated on a cost per amp based on the engineering maximum capacity (80%) of the BDFB (480 amps). The BDFB equipment investment per amp is then multiplied by the power installation factor to come up with a total installed investment cost for a BDFB on a per amp basis. An ACF is then applied to calculate an annual cost and divided by twelve for the monthly recurring cost.

When provisioning power, the distance from the main power source is a critical measurement due to power loss incurred in the cables. In some cases an ICB-Core Drill may be required to reach the collocation area via the best and shortest route.

In addition, the cable fire retardant cost element will apply for each core drill made through a wall or floor.

#### **DC Power Utility**

The DC Power Utility represents the monthly utility expense to power the termination equipment. This cost is determined by estimating a set amperage rating of equipment and a voltage rating of equipment used by collocators. By multiplying the amp rating by the volt rating and dividing by 1000, a total equipment power requirement is calculated.



Power engineers used a Lorain model V200D50 Rectifier in calculating the input-output ratios and efficiency factors for a current power facility. The power output voltage is calculated using the type of rectifier that would be purchased by Verizon today rather than using equipment found in an existing Verizon central office. This has the effect of lowering the ratio of input to output power and reducing the overall cost of this element.

The cost of commercial electricity is determined from actual electricity costs and kilowatt-hours used in Verizon's facilities throughout 2001 and is state-specific. The hourly cost to power the equipment is calculated by multiplying the cost of commercial electricity by the equipment power requirement. The hourly cost is multiplied by the efficiency and heat loss factor (ratio of input power to output power) in determining the monthly recurring cost for DC power utility.

### **Facility Termination**

A Facility Termination includes the installation and materials costs of the Main Distribution Frame (MDF), a 100 pair termination block, and the DSX facility termination panel. Facility termination can be a DS0, DS1, or DS3. A separate cost is developed for each termination. (Refer to Collocation Drawing No. 15 for additional details.)

This cost is determined by calculating the total materials and installation cost for establishing a DS0 (100 pair), DS1 (28 pair), or DS3 coaxial interconnection. It includes the costs of the cross connect panels and termination blocks, and a space occupation cost of those blocks and panels.

For each type of interconnection, a materials cost is established. All materials costs are obtained from GTEAMS. For the DS0 interconnection, the cost of a 100 pair termination block is used. Additionally, the cost of the MDF is calculated on a 100 pair, DS0 basis. The study includes DS0s only up to the point of their termination on the MDF and does not include the cross connections to Verizon's unbundled network elements or services. Therefore, only one half of the cost of the MDF is included in Verizon's collocation study.

The DS1 interconnection cost is a 56 circuit DSX panel, calculated on a cost per circuit. The panel is fully utilized when deploying four cables, each with 28 pairs (2 Transmitting and 2 Receiving). The costs used for a DS3 includes a 20 circuit DSX chassis (calculated on a per circuit basis) and a DS3 module. The panel is fully utilized when deploying all 20 modules.

The installation cost for establishing facility termination includes both engineering and installation activities. Verizon's digital circuit installation factor is multiplied by the materials investment amount to calculate the total installed investment amount. Annual cost factors are applied to the total installed investment for each type of facility termination to annualize the cost. The annual cost is divided by twelve to calculate the monthly recurring cost.

### **Building Modification Costs**

#### *Security Access*

Security Access provides Verizon the ability to install locks on Verizon's existing equipment and file cabinets. The costs are based on estimates from contractors who perform this type of activity. The placement of locking hasps or bars are based on 20 cabinets per central office. The cost for providing a chain type (bicycle) lock is also used for those pieces of equipment that can be locked in a shelf area.

#### *Card Reader*

For physical collocation arrangements, it may be necessary to install a card reader/controller, or a card reader to provide the collocator with secured access to the central office facility. These costs are presented on an equipment type basis. (Refer to Collocation Drawing No. 10 for additional details.)

#### *Site Modification*

##### **Site Preparation**

The Site Preparation element represents the costs to prepare the collocation space for collocation. The cost to clean up any associated debris caused by the site preparation is also included.

##### **Dust Partition**

The dust partition element comprises the cost to place a temporary dust curtain around the construction area. The curtain protects the existing equipment from dust and debris produced during construction projects.

### **HVAC - Minor (Ventilation Ducts)**

The ventilation ducts element includes the cost of making minor duct modifications. (Refer to Collocation Drawing No. 16 for additional details.)

### *Electrical*

#### **Lighting**

The lighting element includes the cost of installing a single four-foot long electrical light, materials, and labor. A manual switch or a motion detector can control the light.

#### **Electrical Outlet**

The electrical outlet cost includes the materials and labor to install a single courtesy AC electrical outlet inside a collocator's access area.

#### **Floor Grounding Bar**

The floor grounding bar is located in the collocation area and is used to provide ground potential to each collocator. The floor grounding bar is grounded to the central office's grounding source. The cost includes all materials and labor required to pull a cable from the main ground source to the collocation area. PVC conduit is used to enclose the ground wire. (Refer to Collocation Drawing Nos. 4 and 5 for additional details.)

#### **Environmental Conditioning**

Environment conditioning includes the costs necessary to provide conditioned space within the central office where the collocator's equipment will be placed.

### **Cable Vault Splice Elements**

#### *Fiber Cable Vault Splice*

The fiber cable vault splice closure is available when a fiber splice is performed inside the cable vault. The closures are based on the size of the fiber cable being spliced. One splice closure can hold 48 fibers and the other up to 96 fibers. The closure costs are found in Verizon's GTEAMS system and are the same type of

closures currently used by Verizon personnel. Materials loadings and an ACF are added to the materials cost. The total cost is divided by twelve to calculate the cost per month. (Refer to Collocation Drawing No. 11 for additional details.)

### ***Metallic Cable Vault Splice***

The Metallic Cable Vault Splice closure is used to splice metallic cable inside the cable vault. A splice is required when metallic cable is provisioned between the Verizon CO and an adjacent collocation arrangement. The outside plant cable is spliced to the central office cable and protection is placed on the vertical side of the main distribution frame. Protection is required to ensure that stray voltage does not enter the central office via the metallic cable.

The cost is based on a Cook type C-388 connector which Verizon personnel currently install on Verizon's own equipment. The protector modules transmit analog or digital signals. The cost for this equipment is found in GTEAMS. The space the connector occupies on the main distribution frame is calculated on a per 100 pair basis. It is calculated by summing the cost of the frame, the associated labor and the number of metallic cable pairs terminated on the vertical side of the frame.

Materials loadings are calculated for the materials used and an ACF is applied to develop the total annual cost. The annual cost is divided by twelve to calculate the cost per month.

Various cable costs are calculated for the different sized cables that may be utilized in the central office by a collocator. (Refer to Collocation Drawing No. 12 for additional details.)

### **Cable Vault Space**

The cable vault space is the area that a collocator's cable occupies inside the central office vault. Costs are based on the diameter of the collocator's cable. The diameters of the various cables are obtained from the manufacturer's specifications for the pair size of metallic cable used. For fiber cable, the outside diameter of the subduct is used to determine the cable vault space needed.

First, the cost of a cable vault space is determined. Second, the area within the vault that the cable occupies is estimated using the size of the cable. Third, the

vault and cable occupancy is calculated on a cubic foot basis. (Refer to Collocation Drawing No. 14 for additional details.)

### **Cable Rack Shared Space**

The cable rack shared space element comprises the area a collocator's cable will occupy when connected from the central office superstructure to the MDF or DSX panel or from collocator to collocator. The Network Design engineering group estimated the quantity of cables that could be placed on a 24-inch cable rack. The diameter of the central office cable is used to determine the amount of space occupied by the cable on a foot of cable rack. The DS0 and DSX cable space occupied are calculated based on the diameter of the cables. The outside diameter of the innerduct is used to calculate fiber cable. This cost is calculated as a monthly rate and based on the total length of the cable. (Refer to Collocation Drawing Nos. 9 and 14 for additional details.)

### **Virtual Frame**

The virtual frame element includes the cost to provide shelving space for a virtual collocator's equipment. The cost includes the frame, materials, and labor costs of installing the frame for the shelf space that the collocator's equipment will occupy within the relay rack. All costs are calculated on a per shelf basis.

The cost is obtained by calculating the materials and labor expenses associated with the virtual frame. Only the materials cost of the frame, using GTEAMS as the source, is included. Additionally, the labor used to engineer, install, and ground the frame is added.

The amount of space occupied by the virtual collocator may vary greatly between sites. Therefore, Verizon offers the frame space cost on a per shelf basis. Verizon estimated 8 feet as the average height of a frame and 24 inches as its width. Depth is considered to be 15 inches. Additionally, the required 36 inches in front of and behind the frame is used as the dedicated space for equipment access. It is assumed that other frames will share some of the space in front and behind the virtual collocators. Thus, Verizon reduced the dedicated space to 18 inches in front of and another 18 inches behind the equipment. The costs associated with the virtual frame include the materials cost of the frame, installation, grounding, and the square footage occupied by the frame. The cost per square foot is obtained from the floor space element calculation.

## **Virtual Maintenance**

The virtual maintenance cost for powered equipment includes:

- Routine maintenance;
- Trouble maintenance; and
- Floor space occupied by the frame in which the collocators' equipment resides.

Routine maintenance recommended by the equipment manufacturer includes cleaning fans, performing visual checks, and testing cards.

Trouble maintenance includes the labor hours that the central office technician will require to resolve trouble tickets, restore the circuit and/or replace cards from the collocator's inventory.

Time estimates for individual tasks are provided by subject matter experts' estimates, including conversations with the central office technicians. All loaded labor rates used are Verizon's actual labor and overhead rates.

A weighted average cost per quarter rack is calculated based on:

- The frequency that each type of equipment is estimated to be collocated; and
- The average number of base units that fit into a standard Verizon relay rack.

## **Microwave Collocation**

Verizon offers one microwave specific monthly recurring element:

The Microwave Rooftop Space element is the cost per square foot to provide rooftop space to the ALEC for microwave antennae and other exterior facilities. Only costs that relate directly to the land and building space are included.

## **Miscellaneous Services**

### **BITS Timing**

Building Integrated Timing Supply (BITS) is a central office timing system that provides a common source for the frequency and phase synchronization necessary in any digital transmission network. BITS clocks are used to provide timing and synchronization information to the equipment elements for a digital

transmission system or network. The clocks are embedded within switching or transport equipment or in stand-alone synchronization equipment such as Timing Signal Generators (TSG) or Primary Reference Sources (PRS). The BITS timing system is simple to administer and trouble-shoot a network of clocks for known quality and performance characteristics. The BITS system ensures that network synchronization, if correctly installed, provides the necessary level of performance demanded by a growing digital network.

The BITS concept requires that all digital equipment in a physical structure receive timing from the BITS/TSG clock. This clock is the most accurate and stable clock in the structure and the only clock that receives timing from another PRS office. The BITS clock receives primary (A) and secondary (B) timing references from another office of higher or stratum levels. These timing references must be and are traceable to a PRS. The primary timing reference serves as the active timing reference; the secondary timing reference is the alternate timing reference if the active reference fails.

The cost is determined by calculating the total material and installation costs of establishing BITS within a central office. It includes the common control equipment and associated port cards. Port cards are available for DS1 or Composite Clock (CC) signal delivery. Because the system is installed with 100 ports for connectivity, the cost is developed as a cost per port. ACFs are applied to the total investment, resulting in an annual cost. The annual cost is divided by twelve to calculate the cost per month, per port.

The standard Verizon BITS unit, Telcom Solution 's DCD-519/2E, is used to determine equipment and installation costs. It comes equipped with a GPS system. (Refer to Collocation Drawing No. 17 for additional details.)

### **Fiber Optic Patch Cord**

The fiber optic patch cord is available to collocated customers who require fiber access to Verizon's unbundled network elements. This section of the collocation cost study presents the development of the recurring costs of the fiber optic patch cord between the collocater's cage, cageless or virtual arrangement and the Verizon fiber distribution panel designated for collocaters. (Refer to Collocation Drawing No. 20 for details.)

The following costs are developed:

- The materials costs of the fiber distribution panel on a per port basis; and

- The cost of the fiber duct system calculated on a per foot basis, which is used to determine an occupancy factor.

### ***Chassis, Relay Rack and Floor Space***

This element includes the cost of the materials, labor, and floor space for the framework used to mount the fiber distribution panel designated for collocators. The cost is based on a "cost per connector" basis.

#### **Materials**

The materials costs for the fiber distribution panel chassis and the optical cross-connect modules are found in GTEAMS. The fiber distribution panel can house 12 modules and each module has six ports. The chassis cost is divided by 12 modules per chassis to derive a chassis and module cost. The cost per port is calculated by dividing the chassis and module cost by six, the number of ports required.

The materials cost for the relay rack is also found in GTEAMS. The average relay rack has the capacity of mounting seven optical cross-connect chassis or fiber distribution panels. The cost of the relay rack is divided by the number of chassis per rack and the number of modules per chassis to calculate the "subtotal relay rack cost per module." The "total material cost" is the sum of the "subtotal chassis and module cost" and the "subtotal relay rack cost per module cost."

#### **Floor Space**

The "floor space cost per relay rack" is calculated by multiplying the relay rack floor space cost per linear foot by the width of the relay rack. The cost of the "floor space per relay rack" is divided by the number of chassis per rack and the number of modules per chassis to calculate the "subtotal floor space cost per relay rack per module." Each module has six connectors. The "subtotal floor space cost per relay rack, per module" is divided by six connectors, resulting in the "floor space cost per connector."

#### **Installation**

The total installation cost is calculated by multiplying the "total materials cost" per connector to the digital circuit installation factor.



The “monthly cost per connector” is finalized by combining the materials, installation, and floor space costs. This number is then multiplied by the appropriate ACF to derive the total annual cost. Dividing the total annual cost by 12 and adding the “floor space cost per connector” results in the monthly cost.

### ***Fiber Guide Duct System***

The fiber guide duct system element includes the materials, engineering, and installation costs for the fiber guide duct system. The system is used to protect, support, and route the fiber patch cord between the collocator’s equipment and Verizon’s designated collocators fiber distribution panel. The rate is offered on a “per foot” basis.

#### **Materials**

To determine the average cost per foot of the fiber guide duct system, 100 linear feet of duct is used. The components required to construct a 100 linear foot duct system is developed from GTEAMS costs. The total cost for a 100-foot duct system is divided by 100 linear feet to develop a cost per foot.

#### **Installation**

Subject matter experts provide the estimated hours for the central office equipment engineer and the equipment installer. The individual installation costs are calculated by multiplying the digital circuit installation factor by the equipment investment.

#### ***Total Investment***

Total investment is the sum of the equipment material and the installation costs. A duct system has a capacity of 250 patch cords. The total investment (materials plus installation) is divided by 250 patch cords to derive an occupancy cost per fiber optic patch cord. This number is multiplied by the appropriate ACF to derive the total annual cost. The monthly cost is calculated by dividing the total annual cost by 12.

MRC FIXED ALLOCATOR: 14.09%

Rate Element	NRC/MRC	Increment	Rate	Source	Page #
<u>Caged, Cageless, Shared, Subleased &amp; Virtual NRC Rate Elements</u>					
1 Engineering/Major Augment - Caged/Cageless	NRC	per occurrence	\$ 1,380.25	Engineering - Major Aug-PS	90
2 Minor Augment	NRC	per occurrence	\$ 256.69	Engineering - Minor Aug-PS	91
3 Access Card Administration	NRC	per card	\$ 31.64	Access Card Admin-PS	94
4 Cage Enclosure 25-100 SF	NRC	per cage	\$ 4,352.70	Cage Enclosure 1-PS	96
5 Cage Enclosure 101-200 SF	NRC	per cage	\$ 5,645.40	Cage Enclosure 2-PS	97
6 Cage Enclosure 201-300 SF	NRC	per cage	\$ 6,938.10	Cage Enclosure 3-PS	98
7 Cage Enclosure 301-400 SF	NRC	per cage	\$ 8,239.14	Cage Enclosure 4-PS	99
8 Cage Enclosure 401-500 SF	NRC	per cage	\$ 9,531.84	Cage Enclosure 5-PS	100
9 Cage Enclosure Augment	NRC	per square foot	\$ 11.81	Cage Enclosure 6-PS	101
10 Cage Grounding Bar	NRC	per bar	\$ 1,423.65	Cage Grounding Bar-PS	104
11 Overhead Superstructure	NRC	per project	\$ 1,247.53	Overhead Superstructure-PS	106
12 Facility Pull - Engineering (Metallic & Fiber Optic Patchcord)	NRC	per project	\$ 83.61	Facility Pull - Eng-PS	109
13 Facility Pull - Labor (Metallic)	NRC	per cable run	\$ 128.80	Facility Pull-PS	110
14 Fiber Optic Patchcord Pull - Labor	NRC	per cable run	\$ 212.75	Facility Pull-PS	110
15 DS0 Cable Termination (Connectorized)	NRC	per 100 pair	\$ 4.60	NRC Facility Term-PS	111
16 DS1 Cable Termination (Connectorized)	NRC	per 28 pair	\$ 1.15	NRC Facility Term-PS	111
17 DS3 Coaxial Cable Termination (Preconnectorized)	NRC	per coaxial cable	\$ 1.15	NRC Facility Term-PS	111
18 DS3 Coaxial Cable Termination (Unconnectorized)	NRC	per coaxial cable	\$ 11.49	NRC Facility Term-PS	111
19 Category 5 Cable Termination (Connectorized)	NRC	per 25 pair	\$ 1.15	NRC Facility Term-PS	111
20 Fiber Optic Patchcord Termination	NRC	per termination	\$ 1.15	NRC Facility Term-PS	111
21 Fiber Cable Pull - Engineering	NRC	per project	\$ 1,371.12	Fiber Cable Pull-PS	115
22 Fiber Cable Pull - Place Innerduct	NRC	per innerduct ft	\$ 0.73	Fiber Cable Pull-PS	115
23 Fiber Cable Pull - Labor	NRC	per linear ft	\$ 0.49	Fiber Cable Pull-PS	115
24 Fiber Cable Pull - Cable Fire Retardant	NRC	per occurrence	\$ 45.98	Fiber Cable Pull-PS	115
25 Fiber Cable Splice - Engineering	NRC	per splicing project	\$ 68.56	Fiber Cable Splice-PS	117
26 Fiber Cable Splice	NRC	per fiber strand	\$ 41.03	Fiber Cable Splice-PS	117
27 DC Power - Engineering	NRC	per project	\$ 83.61	DC Power Cable-PS	119
28 DC Power - Cable Pull/Termination	NRC	per cable	\$ 838.79	DC Power Cable-PS	119
29 DC Power - Ground Wire	NRC	per wire	\$ 9.38	DC Power Cable-PS	119
30 Virtual Equipment Installation	NRC	per quarter rack	\$ 3,693.59	Virtual Equip Install-PS	122

MRC FIXED ALLOCATOR: 14.09%

	Rate Element	NRC/MRC	Increment	Rate	Source	Page #
31	Virtual Software Upgrades	NRC	per base unit	\$ 98.62	Virtual Software-PS	125
32	Virtual Card Installation	NRC	per card	\$ 238.54	Virtual Card Install-PS	128
33	Engineering/Major Augment - Virtual	NRC	per occurrence	\$ 756.67	Engineering - Virtual-PS	131
<b><u>Caged, Cageless, Shared, Subleased &amp; Virtual MRC Rate Elements</u></b>						
34	Building Modification	MRC	per request	\$ 237.96	Building Mod-PS	150
35	Environmental Conditioning	MRC	per 1 amp	\$ 3.21	Environmental Conditioning 1-PS	157
36	Caged Floor Space	MRC	per square ft	\$ 3.83	Floor Space-PS	162
37	Relay Rack Floor Space	MRC	per linear ft	\$ 16.29	Floor Space-PS	162
38	Cabinet Floor Space	MRC	per linear ft	\$ 22.04	Floor Space-PS	162
39	Cable Subduct Space - Manhole	MRC	per subduct	\$ 7.71	Cable Subduct Space-PS	168
40	Cable Subduct Space	MRC	per linear ft	\$ 0.05	Cable Subduct Space-PS	168
41	Fiber Cable Vault Splice - 48 Fiber-Material	MRC	per splice closure	\$ 11.95	Fiber Vault Splice-PS	172
42	Fiber Cable Vault Splice - 96 Fiber-Material	MRC	per splice closure	\$ 36.96	Fiber Vault Splice-PS	172
43	Cable Vault Space - Fiber	MRC	per innerduct	\$ 1.40	Cable Vault Space -PS	180
44	Cable Rack Shared Space - Metallic	MRC	per cable run	\$ 0.18	Cable Rack Space - Metallic-PS	188
45	Cable Rack Shared Space - Fiber	MRC	per innerduct ft	\$ 0.006	Cable Rack Space - Fiber-PS	189
46	DC Power	MRC	per 1 amp	\$ 25.45	DC Power-PS	192
47	Facility Termination - DSO	MRC	per 100 pair	\$ 3.21	Facility Term-PS	201
48	Facility Termination - DS1	MRC	per 28 pair	\$ 10.47	Facility Term-PS	201
49	Facility Termination - DS3	MRC	per coaxial cable	\$ 25.11	Facility Term-PS	201
50	Virtual Equipment Maintenance	MRC	per quarter rack	\$ 77.23	Virtual Equip Maint-PS	218
<b><u>Adjacent On-Site NRC Rate Elements</u></b>						
51	Engineering - Adjacent On Site	NRC	per occurrence	\$ 1,292.21	Engineering - On-Site-PS	134
52	Adjacent Metallic Facility Pull-Engineering	NRC	per project	\$ 83.61	On-Site Facility Pull-PS	136
53	Adjacent Metallic Facility Pull - Labor	NRC	per linear ft	\$ 1.15	On-Site Facility Pull-PS	136
54	Adjacent DSO Cable Termination (Connectorized)	NRC	per 100 pair	\$ 4.60	NRC On-Site Facility Term-PS	137
55	Adjacent DSO Cable Termination (Unconnectorized)	NRC	per 100 pair	\$ 45.98	NRC On-Site Facility Term-PS	137
56	Adjacent DS1 Cable Termination (Connectorized)	NRC	per 28 pair	\$ 1.15	NRC On-Site Facility Term-PS	137
57	Adjacent DS1 Cable Termination (Unconnectorized)	NRC	per 28 pair	\$ 34.48	NRC On-Site Facility Term-PS	137

MRC FIXED ALLOCATOR: 14.09%

	Rate Element	NRC/MRC	Increment	Rate	Source	Page #
58	Adjacent DS3 Coaxial Termination (Connectorized)	NRC	per coaxial cable	\$ 1.15	NRC On-Site Facility Term-PS	137
59	Adjacent DS3 Coaxial Termination (Unconnectorized)	NRC	per coaxial cable	\$ 11.49	NRC On-Site Facility Term-PS	137
60	Adjacent Category 5 Cable Termination (Connectorized)	NRC	per 25 pair	\$ 1.15	NRC On-Site Facility Term-PS	137
61	Adjacent Fiber Cable Termination	NRC	per fiber term	\$ 41.03	NRC On-Site Facility Term-PS	137
62	Adjacent Fiber Cable Pull-Engineering	NRC	per project	\$ 1,371.12	On-Site Fiber Cable Pull-PS	138
63	Adjacent Fiber Cable Pull-Place Innerduct	NRC	per innerduct ft	\$ 0.73	On-Site Fiber Cable Pull-PS	138
64	Adjacent Fiber Cable Pull - Labor	NRC	per linear ft	\$ 0.49	On-Site Fiber Cable Pull-PS	138
65	Adjacent-Cable Fire Retardant	NRC	per occurrence	\$ 45.98	On-Site Fiber Cable Pull-PS	138
66	Adjacent Metallic Cable Pull-Engineering	NRC	per project	\$ 1,371.12	On-Site Metallic Cable Pull-PS	139
67	Adjacent Metallic Cable Pull - Labor	NRC	per linear ft	\$ 0.60	On-Site Metallic Cable Pull-PS	139
68	Adjacent Metallic Cable Splice-Engineering	NRC	per splicing project	\$ 68.56	On-Site Metallic Cable Splice-PS	141
69	Adjacent Metallic Cable Splicing (greater than 200 pair)	NRC	per pair	\$ 0.65	On-Site Metallic Cable Splice-PS	141
70	Adjacent Metallic Cable Splicing (less than 200 pair)	NRC	per pair	\$ 1.20	On-Site Metallic Cable Splice-PS	141
71	Adjacent Fiber Cable Splicing-Engineering	NRC	per splicing project	\$ 68.56	On-Site Fiber Cable Splice-PS	142
72	Adjacent Fiber Cable Splicing (48 fiber cable or less)	NRC	per fiber strand	\$ 41.03	On-Site Fiber Cable Splice-PS	142
73	Adjacent Fiber Cable Splicing (greater than 48 fiber)	NRC	per fiber strand	\$ 38.64	On-Site Fiber Cable Splice-PS	142
<b><u>Adjacent On-Site MRC Rate Elements</u></b>						
74	Adjacent Subduct Space-Manhole	MRC	per subduct	\$ 7.71	On-Site Subduct Space-PS	224
75	Adjacent Subduct Space	MRC	per linear ft	\$ 0.05	On-Site Subduct Space-PS	224
76	Adjacent Conduit Space (4" Duct)-Metallic-Manhole	MRC	per conduit	\$ 14.64	On-Site Conduit Space-PS	225
77	Adjacent Conduit Space (4" Duct)-Metallic Cable	MRC	per linear ft	\$ 0.07	On-Site Conduit Space-PS	225
78	Adjacent Facility Termination DSO Cable-Material	MRC	per 100 pair	\$ 3.21	On-Site Facility Term-PS	226
79	Adjacent Facility Termination DS1 Cable-Material	MRC	per 28 pair	\$ 10.47	On-Site Facility Term-PS	226
80	Adjacent Facility Termination DS3 Cable-Material	MRC	per coaxial cable	\$ 25.11	On-Site Facility Term-PS	226
81	Adjacent Cable Vault Splice (per 1200 pr)-Material	MRC	per splice closure	\$ 593.08	On-Site Cable Vault Splice-PS	227
82	Adjacent Cable Vault Space (per 1200 pr)	MRC	per cable	\$ 5.45	Cable Vault Space-PS	180
83	Adjacent Cable Vault Splice (per 900 pr)-Material	MRC	per splice closure	\$ 432.26	On-Site Cable Vault Splice-PS	227
84	Adjacent Cable Vault Space (per 900 pr)	MRC	per cable	\$ 4.20	Cable Vault Space-PS	178
85	Adjacent Cable Vault Splice (per 600 pr)-Material	MRC	per splice closure	\$ 287.46	On-Site Cable Vault Splice-PS	227
86	Adjacent Cable Vault Space (per 600 pr)	MRC	per cable	\$ 3.00	Cable Vault Space-PS	180

MRC FIXED ALLOCATOR: 14.09%

Rate Element	NRC/MRC	Increment	Rate	Source	Page #
87 Adjacent Cable Vault Splice (per 100 pr) - Material	MRC	per splice closure	\$ 60.76	On-Site Cable Vault Splice-PS	227
88 Adjacent Cable Vault Space (per 100 pr)	MRC	per cable	\$ 0.68	Cable Vault Space-PS	180
89 Adjacent Cable Vault Splice (48 fiber)-Material	MRC	per splice closure	\$ 11.95	On-Site Cable Vault Splice-PS	227
90 Adjacent Cable Vault Splice (96 fiber)-Material	MRC	per splice closure	\$ 36.96	On-Site Cable Vault Splice-PS	227
91 Adjacent Cable Vault Space (fiber)	MRC	per subduct	\$ 1.40	Cable Vault Space-PS	180
92 Adjacent Cable Rack Shared Space - Metallic DSO	MRC	per linear ft	\$ 0.004	On-Site Cable Rack Space-PS	228
93 Adjacent Cable Rack Shared Space - Metallic DS1	MRC	per linear ft	\$ 0.002	On-Site Cable Rack Space-PS	228
94 Adjacent Cable Rack Shared Space - Fiber	MRC	per innerduct ft	\$ 0.006	On-Site Cable Rack Space-PS	228
95 Adjacent Cable Rack Shared Space - Coaxial	MRC	per linear ft	\$ 0.010	On-Site Cable Rack Space-PS	228
<b><u>Miscellaneous NRC Rate Elements</u></b>					
96 BITS Timing	NRC	per project	\$ 209.66	NRC BITS Timing-PS	133
97 Collocation Premise Space Report - Optional	NRC	per co request	\$ 1,354.56	Premise Space Report-PS	143
98 Engineering/Major Augment - Microwave	NRC	per occurrence	\$ 1,091.17	Engineering - Microwave-PS	92
99 Microwave Facility Pull - Labor	NRC	per linear ft	\$ 1.15	Facility Pull-PS	110
100 Facility Cable-DS0 Cable (Connectorized) 100 pair	NRC	per cable run	\$ 265.43	Cable-PS	120
101 Facility Cable-DS1 Cable (Connectorized)	NRC	per cable run	\$ 121.70	Cable-PS	120
102 Facility Cable-DS3 Coaxial Cable	NRC	per cable run	\$ 36.12	Cable-PS	120
103 Facility Cable-Category 5 Connectorized	NRC	per linear ft	\$ 1.14	Cable-PS	120
104 Power Cable-Wire Power 1/0	NRC	per cable run	\$ 32.83	Cable-PS	120
105 Power Cable-Wire Power 2/0	NRC	per cable run	\$ 40.20	Cable-PS	120
106 Power Cable-Wire Power 3/0	NRC	per cable run	\$ 49.58	Cable-PS	120
107 Power Cable-Wire Power 4/0	NRC	per cable run	\$ 62.98	Cable-PS	120
108 Power Cable-Wire Power 350 MCM	NRC	per cable run	\$ 111.89	Cable-PS	120
109 Power Cable-Wire Power 500 MCM	NRC	per cable run	\$ 219.09	Cable-PS	120
110 Power Cable-Wire Power 750 MCM	NRC	per cable run	\$ 337.68	Cable-PS	120
111 Fiber Optic Patchcord-24 Fiber (Connectorized)	NRC	per cable run	\$ 775.15	Cable-PS	120
112 Misc Svcs-Labor-Basic Bus Day-First 1/2 Hr	NRC	per technician	\$ 48.31	Labor-PS	145
113 Misc Svcs-Labor-Basic Bus Day-Each Additional 1/2 Hr	NRC	per technician	\$ 24.15	Labor-PS	145
114 Misc Svcs-Labor-OT Non-Bus Day - First 1/2 Hr	NRC	per technician	\$ 100.00	Labor-PS	145
115 Misc Svcs-Labor-OT Non-Bus Day - Each Addtl 1/2 Hr	NRC	per technician	\$ 75.00	Labor-PS	145
116 Misc Svcs-Labor-Premium Non-Bus Day - First 1/2 Hr	NRC	per technician	\$ 150.00	Labor-PS	145
117 Misc Svcs-Labor-Premium Non-Bus Day - Each Addtl 1/2 Hr	NRC	per technician	\$ 125.00	Labor-PS	145

MRC FIXED ALLOCATOR: 14.09%

Rate Element	NRC/MRC	Increment	Rate	Source	Page #
<b><u>Miscellaneous MRC Rate Elements</u></b>					
118 Microwave Rooftop Space	MRC	per sq ft	\$ 3.83	Floor Space-PS	162
119 BITS Timing	MRC	per port	\$ 10.28	BITS Timing-PS	208
120 Facility Termination - Fiber Optic Patchcord	MRC	per connector	\$ 0.47	Fac Term - Fiber Optic-PS	211
121 Cable Duct Space - Fiber Optic Patchcord	MRC	per fiber strand	\$ 0.14	Duct Space - Fiber Optic-PS	214
<b><u>ICBs for Microwave Collocation</u></b>					
122 Building Penetration for Cable					
123 Special Work					
<b><u>Dedicated Transit Service - DSO</u></b>					
124 Service Order-Semi-Mechanized	NRC	per order	\$ 42.46	Wholesale NRC Study-Rate Summary-Section 1	4
125 Service Order-Manual	NRC	per order	\$ 74.99	Wholesale NRC Study-Rate Summary-Section 1	4
126 Service Connection-CO Wiring	NRC	per circuit	\$ 18.24	Wholesale NRC Study-Rate Summary-Section 1	4
127 Service Connection-Provisioning	NRC	per order	\$ 133.60	Wholesale NRC Study-Rate Summary-Section 1	4
128 Service Order-Disconnect-Semi-Mechanized	NRC	per order	\$ 38.01	Wholesale NRC Study-Rate Summary-Section 1	4
129 Service Order-Disconnect-Manual	NRC	per order	\$ 67.58	Wholesale NRC Study-Rate Summary-Section 1	4
130 Service Connection-Disconnect-Provisioning	NRC	per order	\$ 46.67	Wholesale NRC Study-Rate Summary-Section 1	4
131 Service Connection-Disconnect-CO Wiring	NRC	per circuit	\$ 2.94	Wholesale NRC Study-Rate Summary-Section 1	4
<b><u>Dedicated Transit Service - DS1/DS3</u></b>					
132 Service Order-Semi-Mechanized	NRC	per order	\$ 42.46	Wholesale NRC Study-Rate Summary-Section 1	4
133 Service Order-Manual	NRC	per order	\$ 74.99	Wholesale NRC Study-Rate Summary-Section 1	4
134 Service Connection-CO Wiring - DS1	NRC	per circuit	\$ 19.29	Wholesale NRC Study-Rate Summary-Section 1	4
135 Service Connection-CO Wiring - DS3	NRC	per circuit	\$ 65.59	Wholesale NRC Study-Rate Summary-Section 1	4
136 Service Connection-Provisioning	NRC	per order	\$ 132.73	Wholesale NRC Study-Rate Summary-Section 1	4
137 Service Order-Disconnect-Semi-Mechanized	NRC	per order	\$ 40.30	Wholesale NRC Study-Rate Summary-Section 1	4
138 Service Order-Disconnect-Manual	NRC	per order	\$ 69.87	Wholesale NRC Study-Rate Summary-Section 1	4
139 Service Connection-Disconnect-Provisioning	NRC	per order	\$ 46.67	Wholesale NRC Study-Rate Summary-Section 1	4
140 Service Connection-Disconnect-CO Wiring	NRC	per circuit	\$ 2.94	Wholesale NRC Study-Rate Summary-Section 1	4

MRC FIXED ALLOCATOR: 14.09%

Rate Element	NRC/MRC	Increment	Rate	Source	Page #
<b><u>Dedicated Transit Service - Dark Fiber</u></b>					
141 Service Order-Semi-Mechanized	NRC	per order	\$ 71.47	Wholesale NRC Study-Rate Summary-Section 1	4
142 Service Order-Manual	NRC	per order	\$ 74.43	Wholesale NRC Study-Rate Summary-Section 1	4
143 Service Connection-CO Wiring	NRC	per circuit	\$ 60.29	Wholesale NRC Study-Rate Summary-Section 1	4
144 Service Connection-Provisioning	NRC	per order	\$ 36.20	Wholesale NRC Study-Rate Summary-Section 1	4
145 Service Order-Disconnect-Semi-Mechanized	NRC	per order	\$ 39.53	Wholesale NRC Study-Rate Summary-Section 1	4
146 Service Order-Disconnect-Manual	NRC	per order	\$ 39.53	Wholesale NRC Study-Rate Summary-Section 1	4
147 Service Connection-Disconnect-Provisioning	NRC	per order	\$ 36.20	Wholesale NRC Study-Rate Summary-Section 1	4
148 Service Connection-Disconnect-CO Wiring	NRC	per circuit	\$ 2.94	Wholesale NRC Study-Rate Summary-Section 1	4

Verizon: EIS Study - Florida  
 Cost Summary

Cost Elements	Increment	Single/Shared/ Sublease Cage		Cageless		Adjacent On-Site		Virtual		Miscellaneous Services		Source
		NRC	MRC	NRC	MRC	NRC	MRC	NRC	MRC	NRC	MRC	
<b>Non-recurring Costs</b>												
<b>Engineering/Major Augment</b>												
Initial C.O. Collocation Site	per occ	\$ 1,584.46		\$ 1,584.46								Engineering-CS
Additional Collocation Site	per occ	\$ 1,296.84		\$ 1,296.84								Engineering-CS
<b>Engineering/Minor Augment</b>												
Engineering Microwave	per occ	\$ 256.69		\$ 256.69							\$ 1,091.17	Engineering-CS
Engineering Adjacent On-Site	per occ					\$ 1,292.21						Engineering - On-Site-CS
Engineering Virtual	per occ							\$ 756.67				Engineering - Virtual-CS
<b>Building Modification</b>												
<b>Access Card Administration</b>												
New/Replacement	per card	\$ 27.75		\$ 27.75								Access Card Admin-CS
Change	per card	\$ 3.89		\$ 3.89								Access Card Admin-CS
<b>Cage Enclosure</b>												
<b>Cage Fencing</b>												
100 and Over square feet Floor Space	1SF fencing	\$ 8.34										Cage Enclosure 1-CS
75 - 99 square feet Floor Space	1SF fencing	\$ 8.88										Cage Enclosure 1-CS
50 - 74 square feet Floor Space	1SF fencing	\$ 9.78										Cage Enclosure 1-CS
25 - 49 square feet Floor Space	1SF fencing	\$ 11.81										Cage Enclosure 1-CS
Cage Gate	per gate	\$ 518.79										Cage Enclosure 1-CS
Cage Grounding Bar	per bar	\$ 1,423.65										Cage Grounding Bar-CS
<b>Overhead Superstructure</b>												
Installation	1 lin ft	\$ 31.99		\$ 31.99								Overhead Superstructure 1-CS
Materials - Racking	1 lin ft	\$ 21.84		\$ 21.84								Overhead Superstructure 1-CS
<b>Facility Pull</b>												
<b>Engineering</b>												
Engineering	per project	\$ 37.63		\$ 37.63		\$ 37.63		\$ 37.63		\$ 37.63		Facility Pull & Term-CS
Travel Time for Installer	per project	\$ 45.98		\$ 45.98		\$ 45.98		\$ 45.98				Facility Pull & Term-CS
<b>Per DSO Cable</b>												
Per Foot Pull (labor)	1 lin ft	\$ 1.15		\$ 1.15		\$ 1.15		\$ 1.15				Facility Pull & Term-CS
Per Termination (C)	per 100 pr	\$ 4.60		\$ 4.60		\$ 4.60		\$ 4.60				Facility Pull & Term-CS
Per Termination (UC)	per 100 pr					\$ 45.98						Facility Pull & Term-CS
<b>Per DS1 Cable</b>												
Per Foot Pull (labor)	1 lin ft	\$ 1.15		\$ 1.15		\$ 1.15		\$ 1.15				Facility Pull & Term-CS
Per Termination (C)	per 28 pr	\$ 1.15		\$ 1.15		\$ 1.15		\$ 1.15				Facility Pull & Term-CS
Per Termination (UC)	per 28 pr					\$ 34.48						Facility Pull & Term-CS
<b>Per DS3 (coaxial)</b>												
Per Foot Pull (labor)	1 lin ft	\$ 1.15		\$ 1.15		\$ 1.15		\$ 1.15				Facility Pull & Term-CS
Per Termination (Preconnectorized)	per term	\$ 1.15		\$ 1.15		\$ 1.15		\$ 1.15				Facility Pull & Term-CS
Per Termination (Unconnectorized)	per term	\$ 11.49		\$ 11.49		\$ 11.49		\$ 11.49				Facility Pull & Term-CS



Verizon: EIS Study - Florida  
 Cost Summary

Cost Elements	Increment	Single/Shared/ Sublease Cage		Cageless		Adjacent On-Site		Virtual		Miscellaneous Services		Source
		NRC	MRC	NRC	MRC	NRC	MRC	NRC	MRC	NRC	MRC	
<b>Non-recurring Costs</b>												
<b>Per Fiber Cable</b>												
Per Termination (48 fiber cable or less)	per fiber					\$ 41.03						Facility Pull & Term-CS
Per Termination (greater than 48 fiber cable)	per fiber					\$ 38.64						Facility Pull & Term-CS
<b>Fiber Optic Patchcord</b>												
Per Foot Pull (labor)	1 lin ft	\$ 1.15		\$ 1.15				\$ 1.15				Facility Pull & Term-CS
Per Termination	per term	\$ 1.15		\$ 1.15				\$ 1.15				Facility Pull & Term-CS
<b>Category 5 Cable</b>												
Per Foot Pull (labor)	1 lin ft	\$ 1.15		\$ 1.15		\$ 1.15		\$ 1.15				Facility Pull & Term-CS
Per Termination	per 25 pr	\$ 1.15		\$ 1.15		\$ 1.15		\$ 1.15				Facility Pull & Term-CS
<b>Per DS3 (coaxial)-Microwave</b>												
Per Foot Pull (labor)	1 lin ft									\$ 1.15		Facility Pull & Term-CS
<b>Fiber Cable Pull</b>												
Engineering	per project	\$ 1,371.12		\$ 1,371.12		\$ 1,371.12		\$ 1,371.12				Fiber Cable Pull-CS
Place Innerduct	1 lin ft	\$ 0.73		\$ 0.73		\$ 0.73		\$ 0.73				Fiber Cable Pull-CS
Labor	1 lin ft	\$ 0.49		\$ 0.49		\$ 0.49		\$ 0.49				Fiber Cable Pull-CS
Cable Fire Retardant	per occ	\$ 45.98		\$ 45.98		\$ 45.98		\$ 45.98				Fiber Cable Pull-CS
<b>Metallic Cable Pull</b>												
Engineering	per project					\$ 1,371.12						Metallic Cable Pull-CS
Labor (< 1.5" Dia.)	1 lin ft					\$ 0.60						Metallic Cable Pull-CS
Labor (> 1.5" Dia.)	1 lin ft					\$ 0.60						Metallic Cable Pull-CS
Cable Fire Retardant	per occ					\$ 45.98						Metallic Cable Pull-CS
<b>Cable Splice</b>												
<b>Metallic</b>												
Engineering	per splicing project					\$ 68.56						Cable Splice-CS
Splicing (greater than 200 pair)	per pair					\$ 0.65						Cable Splice-CS
Splicing (200 pair or less)	per pair					\$ 1.20						Cable Splice-CS
<b>Fiber</b>												
Engineering	per splicing project	\$ 68.56		\$ 68.56		\$ 68.56		\$ 68.56				Cable Splice-CS
Splicing (48 fiber cable or less)	per fiber strand	\$ 41.03		\$ 41.03		\$ 41.03		\$ 41.03				Cable Splice-CS
Splicing (greater than 48 fiber cable)	per fiber strand	\$ 38.64		\$ 38.64		\$ 38.64		\$ 38.64				Cable Splice-CS
<b>DC Power Cable</b>												
Termination	per pwt run	\$ 68.96		\$ 68.96				\$ 68.96				Cable Run Labor-CS
Power Cable Pull - Labor	1 lin ft	\$ 11.49		\$ 11.49				\$ 11.49				Cable Run Labor-CS
Engineering	per project	\$ 37.63		\$ 37.63				\$ 37.63				Cable Run Labor-CS
Wire Ground #6	1 lin ft	\$ 0.14		\$ 0.14				\$ 0.14				Cable-CS
Travel Time	per project	\$ 45.98		\$ 45.98				\$ 45.98				Cable Run Labor-CS

Verizon: EIS Study - Florida  
 Cost Summary

Cost Elements	Increment	Single/Shared/ Sublease Cage		Cageless		Adjacent On-Site		Virtual		Miscellaneous Services		Source
		NRC	MRC	NRC	MRC	NRC	MRC	NRC	MRC	NRC	MRC	
<b>Non-recurring Costs</b>												
<b>Cable</b>												
<b>Facility Cable</b>												
DS-0 Cable (Connectorized) 100 pair	100 ft									\$ 155.22		Cable-CS
DS-1 Cable (Connectorized)	100 ft									\$ 154.05		Cable-CS
DS-3 Coax Cable	1 lin ft									\$ 0.42		Cable-CS
Shielded Cable (Orange jacket)	1 lin ft									\$ 0.15		Cable-CS
Category 5 Connectorized (per100 feet)	100 ft									\$ 116.52		Cable-CS
Category 5 Connectorized (per150 feet)	150 ft									\$ 169.80		Cable-CS
Category 5 Connectorized (per200 feet)	200 ft									\$ 223.09		Cable-CS
<b>Power Cable</b>												
Wire Power 1/0	1 lin ft									\$ 0.49		Cable-CS
Wire Power 2/0	1 lin ft									\$ 0.60		Cable-CS
Wire Power 3/0	1 lin ft									\$ 0.74		Cable-CS
Wire Power 4/0	1 lin ft									\$ 0.94		Cable-CS
Wire Power 350 MCM	1 lin ft									\$ 1.67		Cable-CS
Wire Power 500 MCM	1 lin ft									\$ 3.27		Cable-CS
Wire Power 750 MCM	1 lin ft									\$ 5.04		Cable-CS
<b>Ground Cable</b>												
Wire Ground #6	1 lin ft									\$ 0.14		Cable-CS
<b>Fiber Optic Patchcord</b>												
24 Fiber Strands (Connectorized)	1 lin ft									\$ 4.19		Cable-CS
<b>Virtual Equipment Installation</b>	per quarter rack								\$ 3,693.59			Virtual Equip Blended-CS
<b>Software Upgrades (per upgrade)</b>	per base unit								\$ 98.62			Virtual Software Blended-CS
<b>Card Installation</b>	per card								\$ 238.54			Virtual Card Install Blended-CS
<b>BITS Timing</b>												
Engineering	per project									\$ 37.63		Cable Run Labor-CS
Pull Shielded Cable	1 lin ft									\$ 1.15		Cable Run Labor-CS
Terminate Shielded Cable	per term									\$ 1.15		Cable Run Labor-CS
Material Cost (orange shielded cable)	1 lin ft									\$ 0.15		Cable-CS
<b>Premise Space Report</b>												
Comprehensive Evaluation	per project									\$ 6,020.26		Premise Space Report-CS
Annual Evaluation	per project									\$ 4,816.21		Premise Space Report-CS

Verizon: EIS Study - Florida  
 Cost Summary

Cost Elements	Increment	Single/Shared/ Sublease Cage		Cageless		Adjacent On-Site		Virtual		Miscellaneous Services		Source
		NRC	MRC	NRC	MRC	NRC	MRC	NRC	MRC	NRC	MRC	
<b>Monthly Recurring Costs</b>												
<b>Building Modification</b>												
Storage Security	per collo office	/	\$ 61.82	/	\$ 61.82	/	/	/	/	/	/	Storage Security-CS
<b>Security Access</b>												
Card Reader	per reader	/	\$ 176.18	/	\$ 176.18	/	/	/	/	/	/	Carder Reader-CS
Controller	per controller	/	\$ 73.81	/	\$ 73.81	/	/	/	/	/	/	Carder Reader-CS
<b>Site Modifications</b>												
Site Preparation	per request	/	\$ 29.47	/	\$ 29.47	/	/	/	/	/	/	Site Mod-CS
Dust Partition	per request	/	\$ 44.50	/	\$ 44.50	/	/	/	/	/	/	Site Mod-CS
HVAC - Minor (Heating, Ventilating & Air Conditioning)	per occ	/	\$ 36.46	/	\$ 36.46	/	/	/	/	/	/	Site Mod-CS
<b>Electrical</b>												
Light	per unit	/	\$ 21.74	/	\$ 21.74	/	/	/	/	/	/	Lighting Fixture-CS
Electrical Outlet	per outlet	/	\$ 19.51	/	\$ 19.51	/	/	/	/	/	/	Elect Outlet-CS
Floor Ground Bar	per bar	/	\$ 54.14	/	\$ 54.14	/	/	/	/	/	/	Floor Ground Bar-CS
Environmental Conditioning	per 1 amp	/	\$ 2.81	/	\$ 2.81	/	/		\$ 2.81	/	/	Environmental Conditioning 1-C
<b>Floor Space</b>												
Caged Floor Space	1 sq ft	/	\$ 3.36	/		/	/	/	/	/	/	Floor Space 1-CS
Microwave Rooftop Space	1 sq ft	/		/		/	/	/		\$ 3.36	/	Floor Space 1-CS
Relay Rack Floor Space	1 lin ft	/		/	\$ 14.28	/	/	/	/	/	/	Floor Space 1-CS
Cabinet Floor Space	1 lin ft	/		/	\$ 19.32	/	/	/	/	/	/	Floor Space 1-CS
<b>Cable Space</b>												
<b>Subduct</b>												
Manhole	per subduct	/	\$ 6.76	/	\$ 6.76	/	\$ 6.76	/	\$ 6.76	/	/	Cable Space 1-CS
Subduct	1 lin ft	/	\$ 0.04	/	\$ 0.04	/	\$ 0.04	/	\$ 0.04	/	/	Cable Space 1-CS
<b>Conduit Space - 4" Duct - Metallic Cable</b>												
Manhole	per conduit	/		/		/	\$ 12.83	/		/	/	Cable Space 1-CS
Conduit	1 lin ft	/		/		/	\$ 0.06	/		/	/	Cable Space 1-CS
<b>Cable Vault Splice</b>												
<b>Metallic Cable per 1200 pair</b>												
Material	per splice closure	/		/		/	\$ 519.83	/		/	/	Cable Vault Splice 1-CS
Utilization Factor in Cable Vault	per cable	/		/		/	\$ 4.78	/		/	/	Cable Vault Space 1-CS
<b>Metallic Cable per 900 pair</b>												
Material	per splice closure	/		/		/	\$ 378.87	/		/	/	Cable Vault Splice 1-CS
Utilization Factor in Cable Vault	per cable	/		/		/	\$ 3.68	/		/	/	Cable Vault Space 1-CS
<b>Metallic Cable per 600 pair</b>												
Material	per splice closure	/		/		/	\$ 251.95	/		/	/	Cable Vault Splice 1-CS
Utilization Factor in Cable Vault	per cable	/		/		/	\$ 2.63	/		/	/	Cable Vault Space 1-CS
<b>Metallic Cable per 100 pair</b>												
Material	per splice closure	/		/		/	\$ 53.25	/		/	/	Cable Vault Splice 1-CS
Utilization Factor in Cable Vault	per cable	/		/		/	\$ 0.60	/		/	/	Cable Vault Space 1-CS
<b>Fiber - 48 fiber strand cable</b>												
Material	per splice closure	/	\$ 10.48	/	\$ 10.48	/	\$ 10.48	/	\$ 10.48	/	/	Cable Vault Splice 1-CS

Verizon: EIS Study - Florida  
 Cost Summary

Cost Elements	Increment	Single/Shared/ Sublease Cage		Cageless		Adjacent On-Site		Virtual		Miscellaneous Services		Source
		NRC	MRC	NRC	MRC	NRC	MRC	NRC	MRC	NRC	MRC	
Utilization Factor in Cable Vault	per innerduct	/	\$ 1.23	/	\$ 1.23	/	\$ 1.23	/	\$ 1.23	/	/	Cable Vault Space 1-CS
<b>Fiber - 96 fiber strand cable</b>												
Material	per splice closure	/	\$ 32.39	/	\$ 32.39	/	\$ 32.39	/	\$ 32.39	/	/	Cable Vault Splice 1-CS
Utilization Factor in Cable Vault	per innerduct	/	\$ 1.23	/	\$ 1.23	/	\$ 1.23	/	\$ 1.23	/	/	Cable Vault Space 1-CS
<b>Monthly Recurring Costs</b>												
<b>Cable Rack Shared Space</b>												
Metallic DSO Cable	per LF	/	\$ 0.004	/	\$ 0.004	/	\$ 0.004	/	\$ 0.004	/	/	Cable Rack Space 1-CS
Metallic DS1 Cable	per LF	/	\$ 0.002	/	\$ 0.002	/	\$ 0.002	/	\$ 0.002	/	/	Cable Rack Space 1-CS
Fiber Cable	per LF innerduct	/	\$ 0.005	/	\$ 0.005	/	\$ 0.005	/	\$ 0.005	/	/	Cable Rack Space 1-CS
Coaxial Cable	per LF	/	\$ 0.001	/	\$ 0.001	/	\$ 0.001	/	\$ 0.001	/	/	Cable Rack Space 1-CS
<b>DC Power Facility</b>												
Power Supply	1 amps	/	\$ 17.69	/	\$ 17.69	/		/	\$ 17.69	/	/	DC Power Fac 1-CS
Fuses and Fuse Panels (BDFB)	1 amps	/	\$ 0.38	/	\$ 0.38	/		/	\$ 0.38	/	/	DC Power Fac 1-CS
Power Cable Pull - Labor	1 amps	/	\$ 1.22	/	\$ 1.22	/		/	\$ 1.22	/	/	DC Power Fac 1-CS
<b>DC Power Utility</b>												
	1 amps	/	\$ 3.02	/	\$ 3.02	/		/	\$ 3.02	/	/	DC Power Util 1-CS
<b>Facility Termination</b>												
DSO Cable - Material	per 100 pr.	/	\$ 2.81	/	\$ 2.81	/	\$ 2.81	/	\$ 2.81	/	/	Fac Term 1-CS
DS1 Cable - Material	per 28	/	\$ 9.18	/	\$ 9.18	/	\$ 9.18	/	\$ 9.18	/	/	Fac Term 3-CS
DS3 Cable - Material	per coaxial	/	\$ 22.01	/	\$ 22.01	/	\$ 22.01	/	\$ 22.01	/	/	Fac Term 5-CS
<b>BITS Timing</b>												
BITS Timing - Material and Labor	per port	/		/		/		/		/	\$ 9.01	BITS Timing 1-CS
<b>Facility Termination - Fiber Optic Patchcord</b>												
	per connector	/		/		/		/		/	\$ 0.41	Fac Term - Fiber Optic 1-CS
<b>Cable Duct Space - Fiber Optic Patchcord</b>												
	per foot per strand	/		/		/		/		/	\$ 0.001	Duct Space - Fiber Optic 1-CS
<b>Virtual Frame Space and Maintenance</b>												
Virtual Frame Space	per quarter rack	/		/		/		/	\$ 9.07	/	/	Virtual Frame Space 1-CS
Virtual Equipment Maintenance	per base unit	/		/		/		/	\$ 58.62	/	/	Virtual Equip Maint Blended-CS

## Verizon Expanded Interconnection Services Collocation Drawings

	Page	
No. 1	Types of Collocation	50
No. 2	DC Power Layout	51
No. 3	Battery Distribution Fuse Bay	52
No. 4	Collocation Grounding System	53
No. 5	Types of Grounding	54
No. 6	Cageless - Relay Rack	55
No. 7	Cageless - Telephone Equipment Cabinet	56
No. 8	Cable Racking Detail	57
No. 9	Shared - Dedicated Cable Racking	58
No. 10	Security Access	59
No. 11	Fiber - Cable Pull, Cable Facility & Cable Space	60
No. 12	Metallic - Cable Pull, Cable Facility & Cable Space	61
No. 13	Connectorized and Unconnectorized Connections	62
No. 14	Utilization Factors	63
No. 15	Cable Termination	64
No. 16	Ventilation Ducts ( HVAC-Minor)	65
No. 17	BITS Timing	66
No. 18	Collocation Provisioning	67
No. 19	Adjacent On-Site Provisioning	68
No. 20	Fiber Optic Patch Cord	69

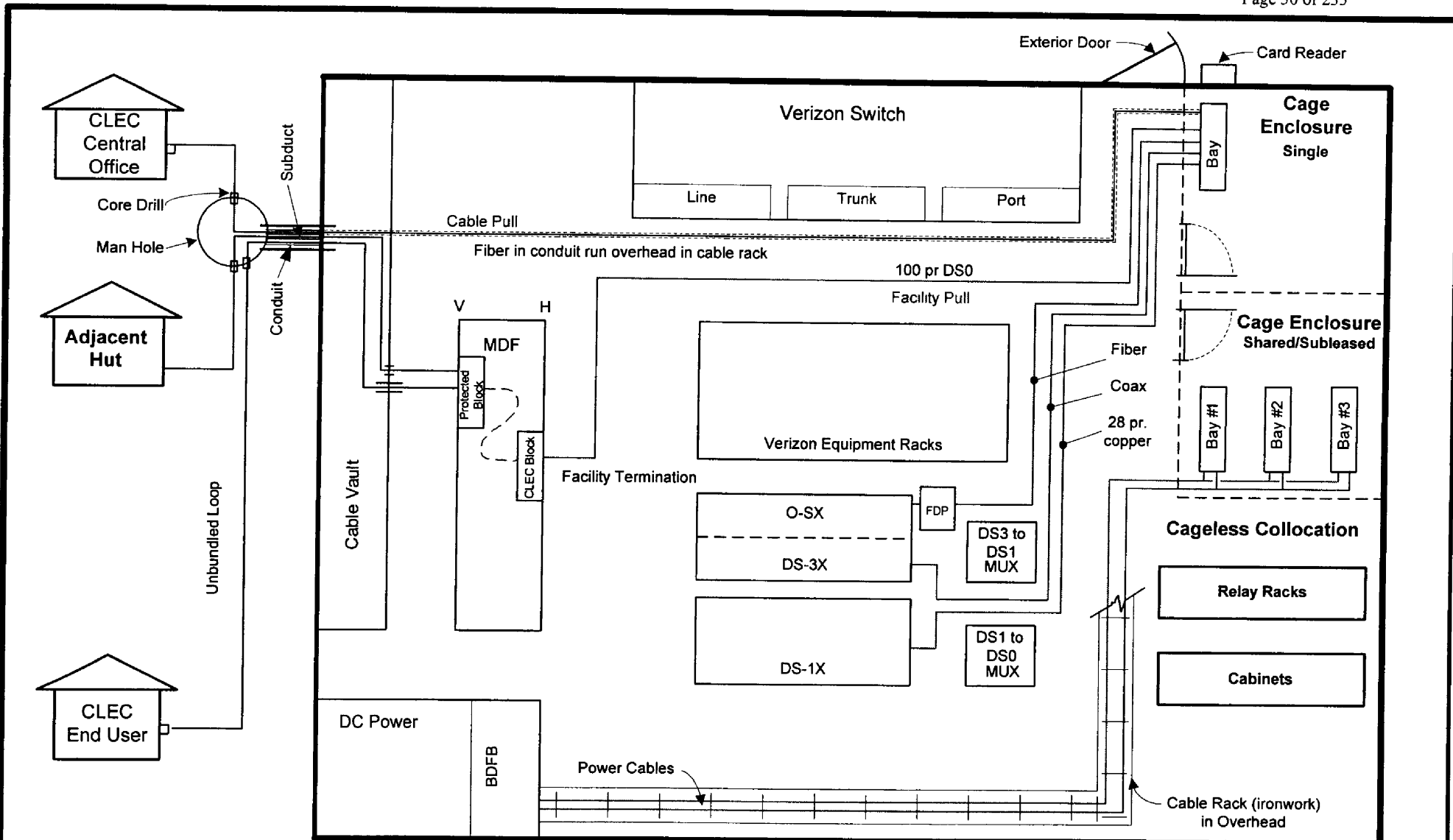

GTE Central Office

Note:  
 This drawing is presented for illustrative purposes only. It presents one of many office layouts and construction alternatives. It is not intended as a contract document. Drawing is not to scale. 09/27/00 - d

**Types of Collocation**  
**Collocation Office Layout**

**Collocation Drawing No. 1**

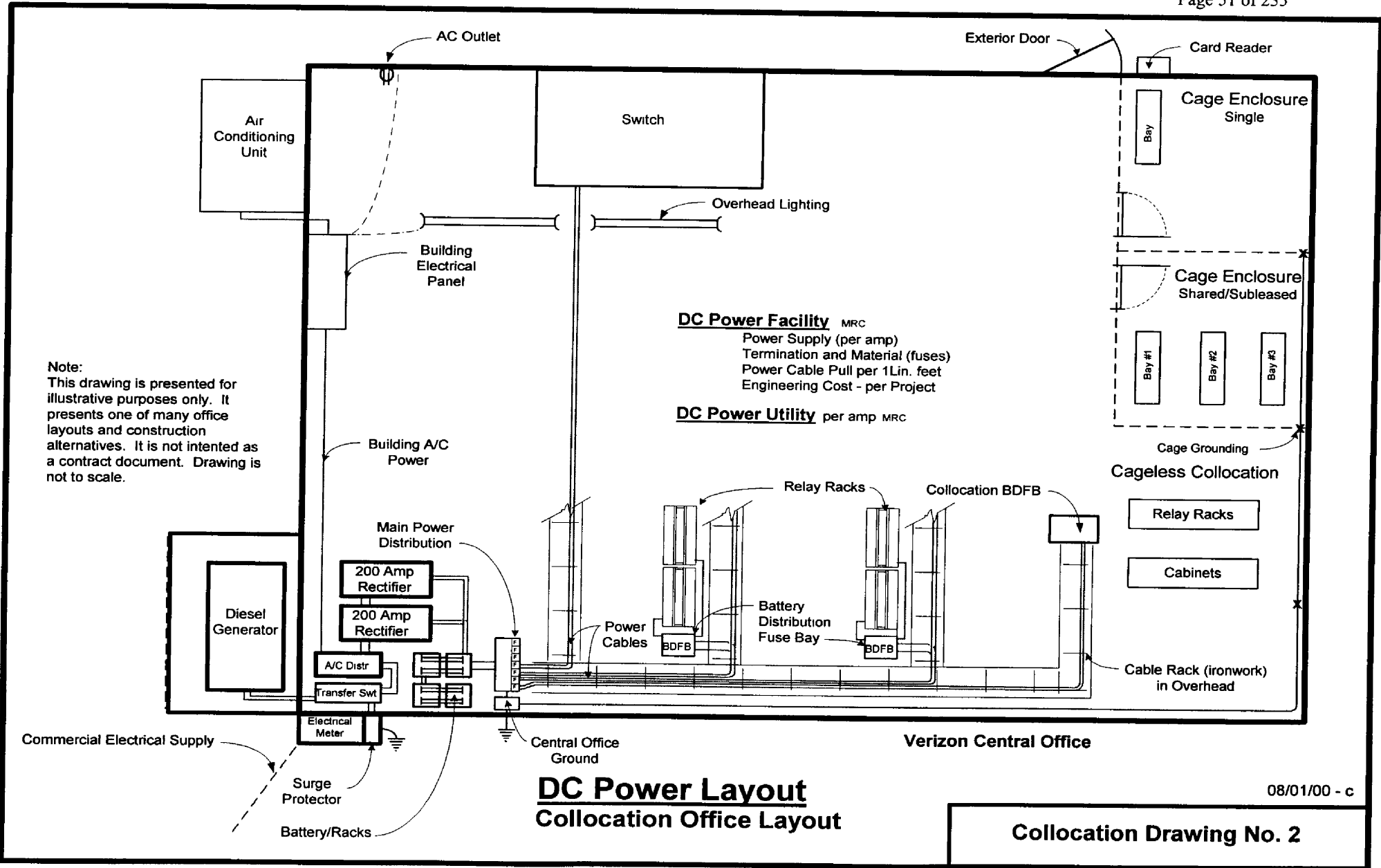

750 MCM Power  
Cables from Main  
Power Distribution

Power Cables to  
Equipment Based on  
Amps

750 MCM Power  
Cables from Main  
Power Distribution

Power Cables to  
Equipment Based on  
Amps

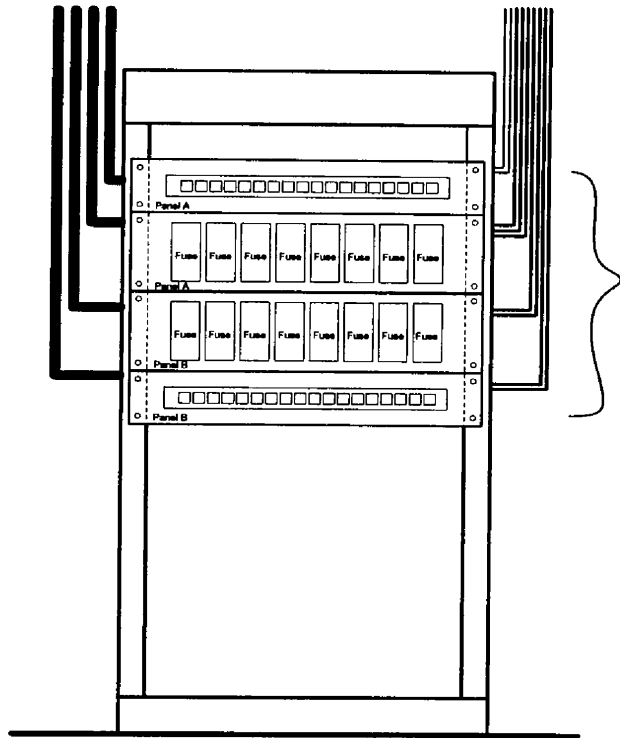

Output to  
Equipment is  
Based on per  
amp increments

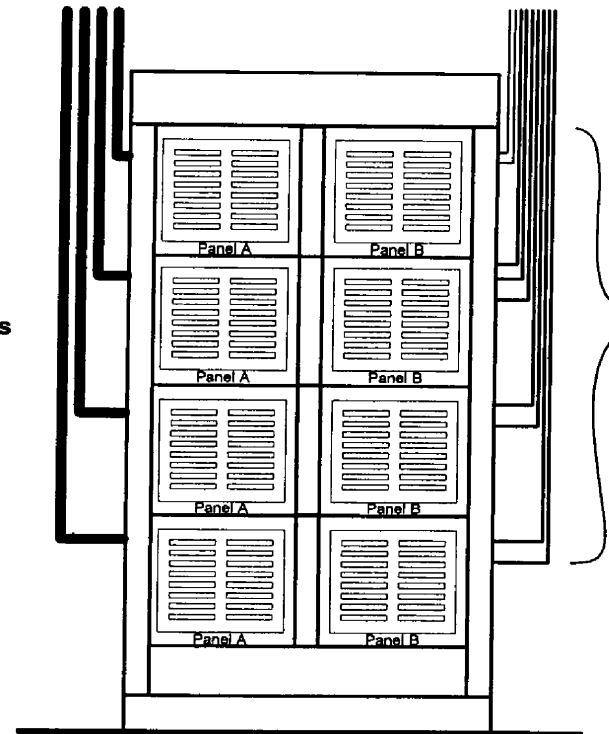

Output to  
Equipment is  
Based on per amp  
increments

Note.  
This drawing is presented for illustrative purposes  
only. It presents one of many office layouts and  
construction alternatives. It is not intended as a  
contract document. Drawing is not to scale.

**Battery Distribution Fuse Bay**  
Collocation Office Layout

08/01/00 - c

**Collocation Drawing No. 3**



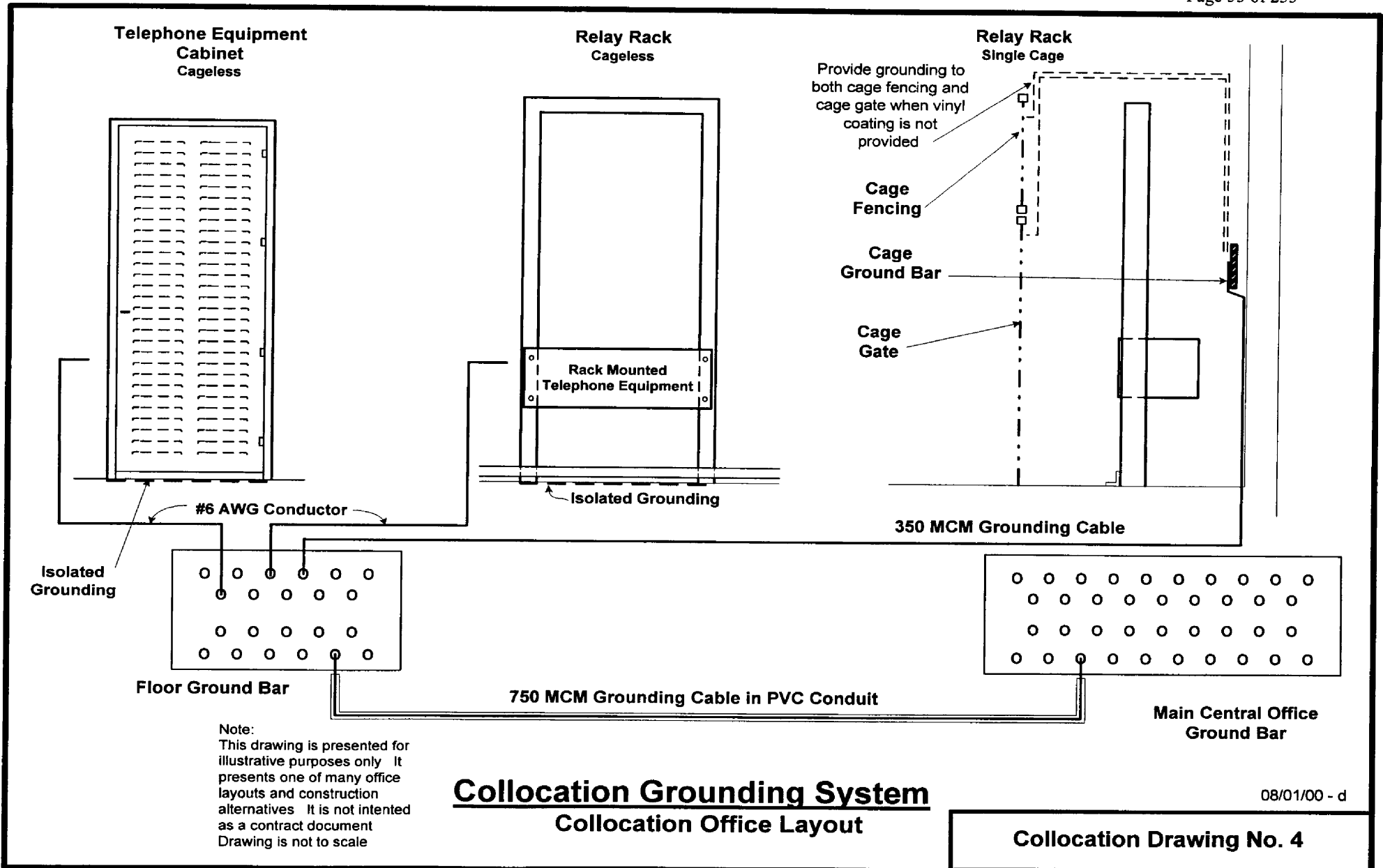

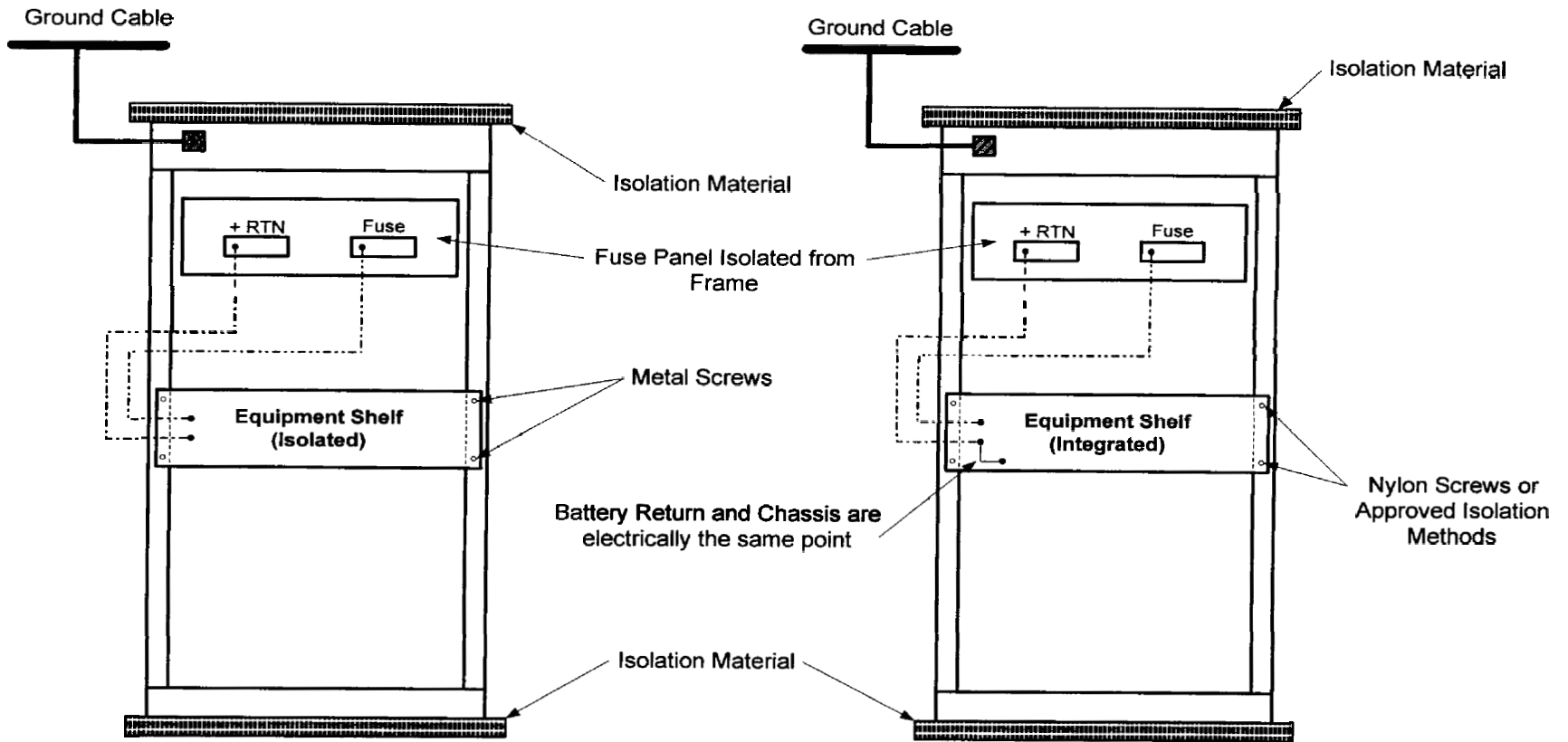

**Isolated Grounding**  
**in a Single Point Grounded Relay Rack**

**Integrated Grounding**  
**in a Single Point Grounded Relay Rack**

**Types of Grounding**  
**Collocation Office Layout**

Note:  
This drawing is presented for illustrative purposes only. It presents one of many office layouts and construction alternatives. It is not intended as a contract document. Drawing is not to scale.

08/01/00 - b

**Collocation Drawing No. 5**

Note:  
 This drawing is presented for illustrative purposes only. It presents one of many office layouts and construction alternatives. It is not intended as a contract document. Drawing is not to scale.

**Relay Rack Floor Space is calculated based on a 12" by 51" area basis. This equates to 4.25 square feet per linear foot.**

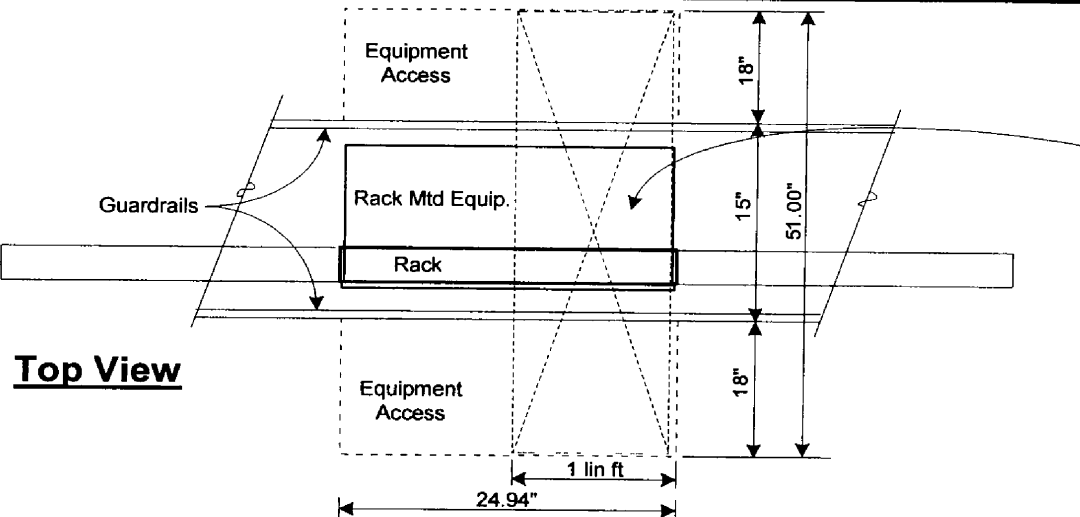

**Top View**

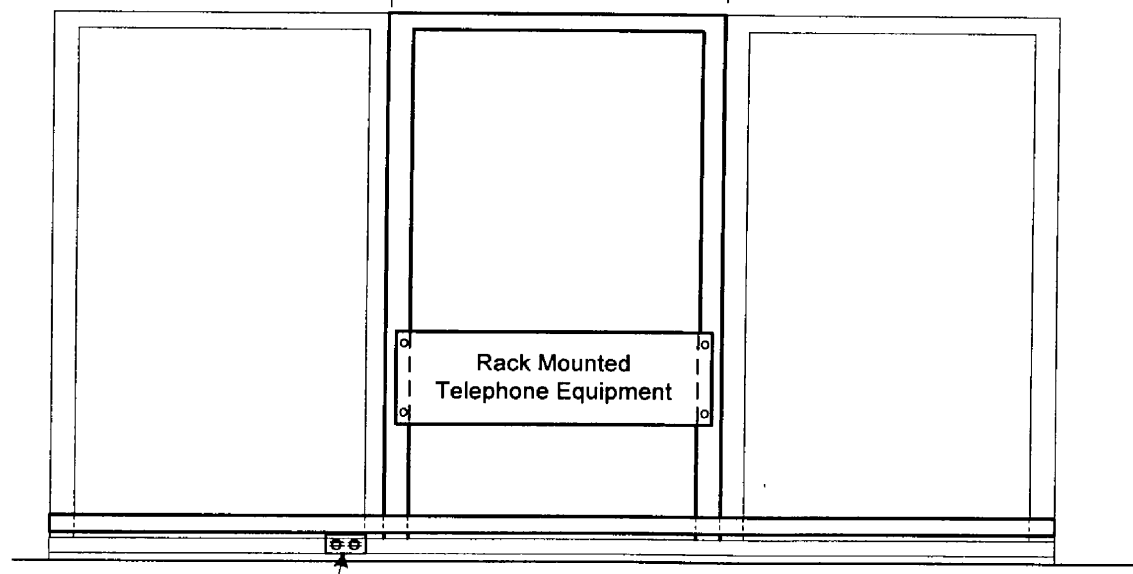

**Front View**

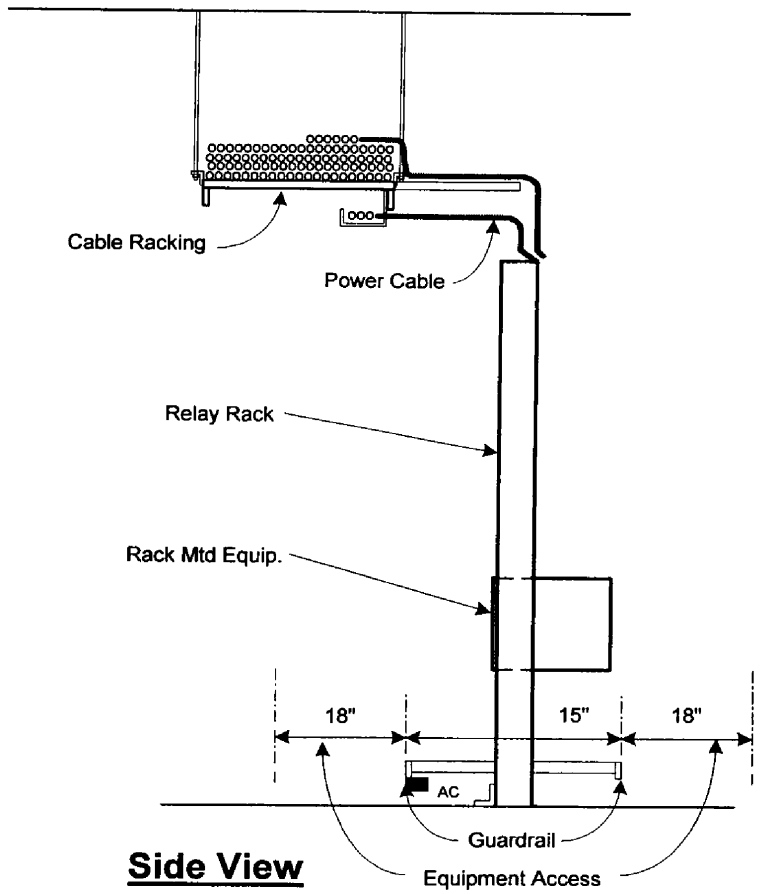

**Side View**

**Cageless - Relay Rack  
 Collocation Typical Office Layout**

09/01/99

**Collocation Drawing No. 6**

**Top View**

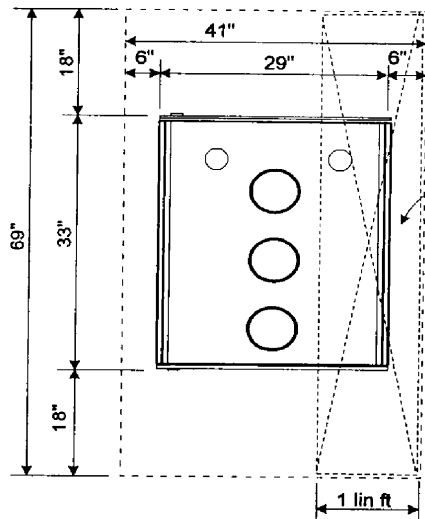

Note:  
 This drawing is presented for illustrative purposes only. It presents one of many office layouts and construction alternatives. It is not intended as a contract document. Drawing is not to scale.

Cabinet Floor Space is calculated based on a 12" by 69" area basis. This equates to 5.75 square feet per linear foot.

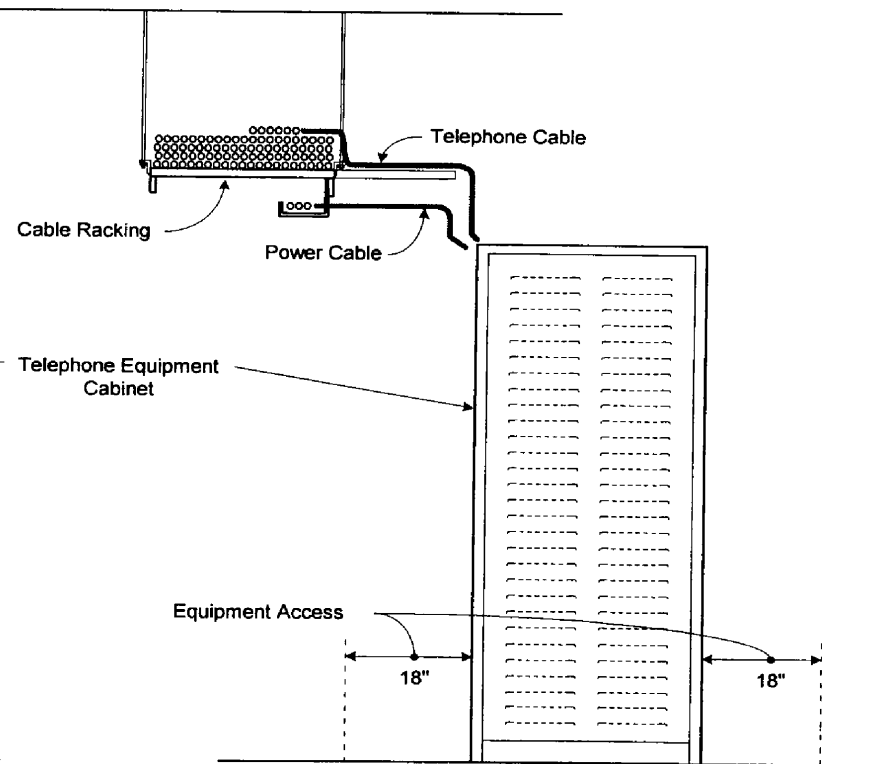

**Front View**

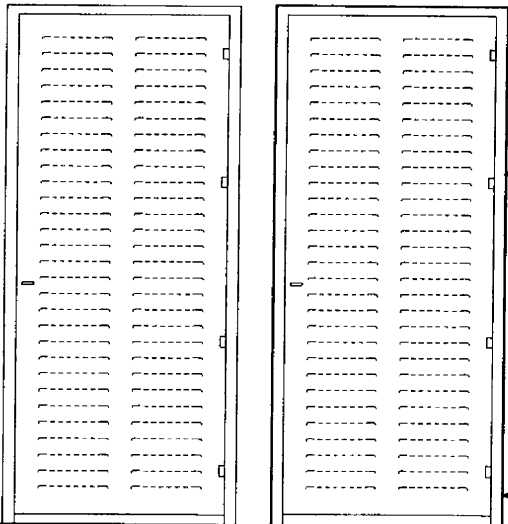

**Cageless - Telephone Equipment Cabinet**

Collocation Office Layout

**Side View**

Collocation Drawing No. 7

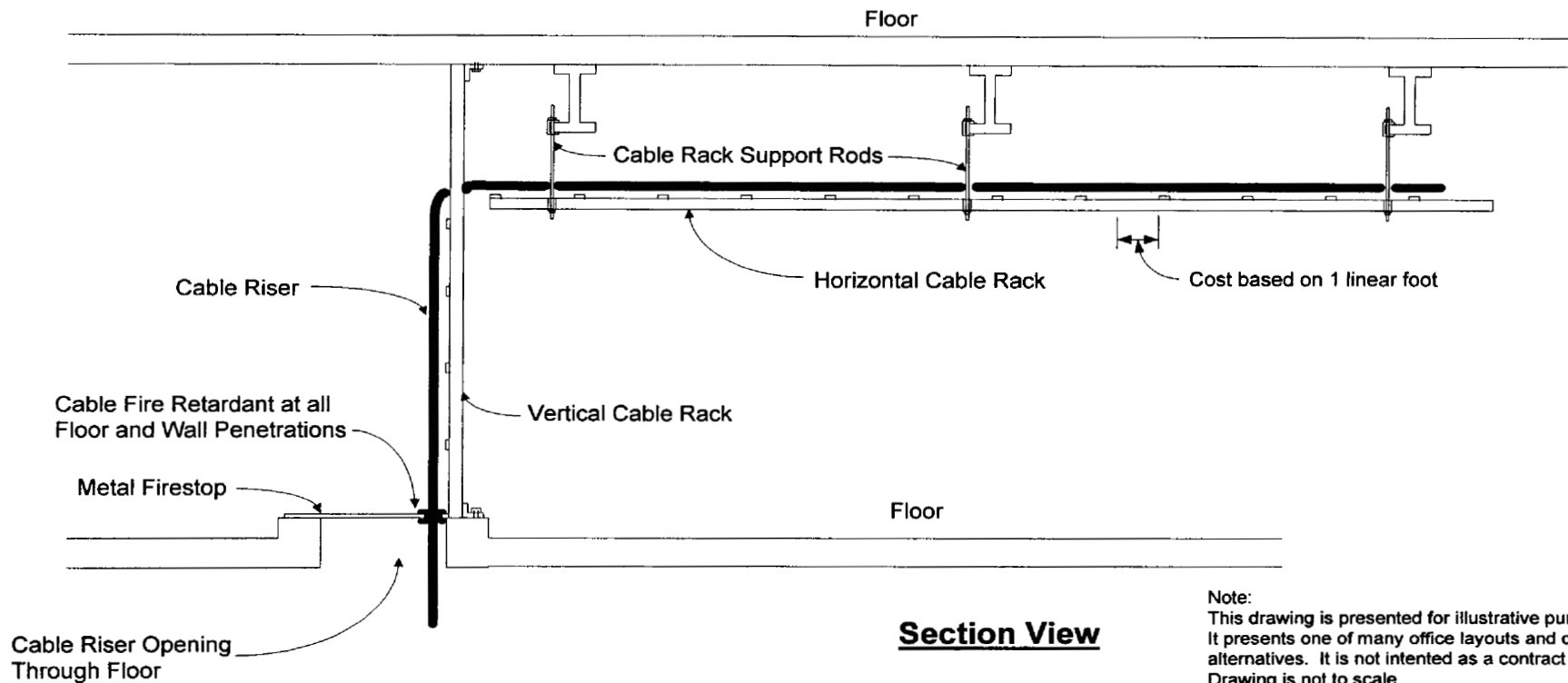
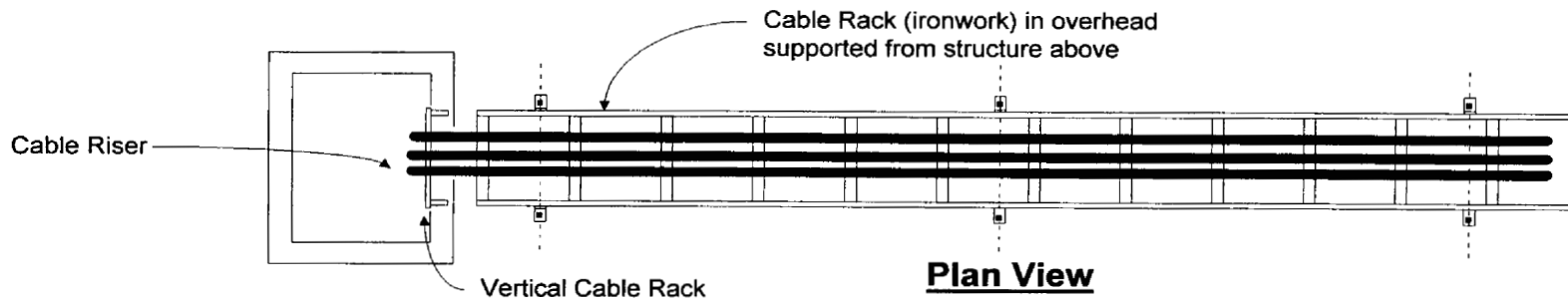

Note:  
This drawing is presented for illustrative purposes only.  
It presents one of many office layouts and construction  
alternatives. It is not intended as a contract document.  
Drawing is not to scale.

**Overhead Superstructure Detail**  
**Collocation Office Layout**

08/01/00 - c

**Collocation Drawing No. 8**

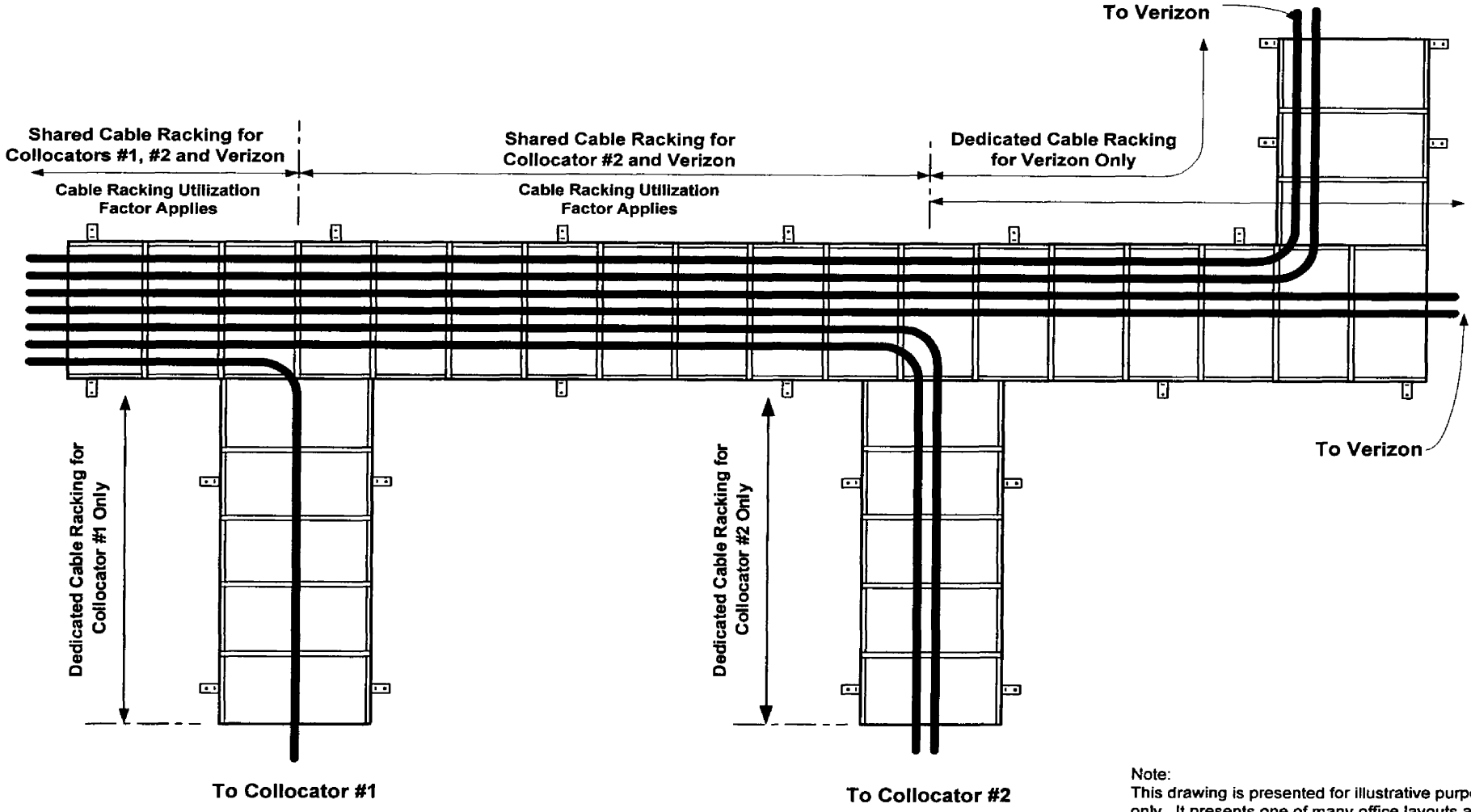

Note:  
This drawing is presented for illustrative purposes only. It presents one of many office layouts and construction alternatives. It is not intended as a contract document. Drawing is not to scale.

**Shared - Dedicated Cable Racking**  
**Collocation Office Layout**

08/01/00 - b

**Collocation Drawing No. 9**

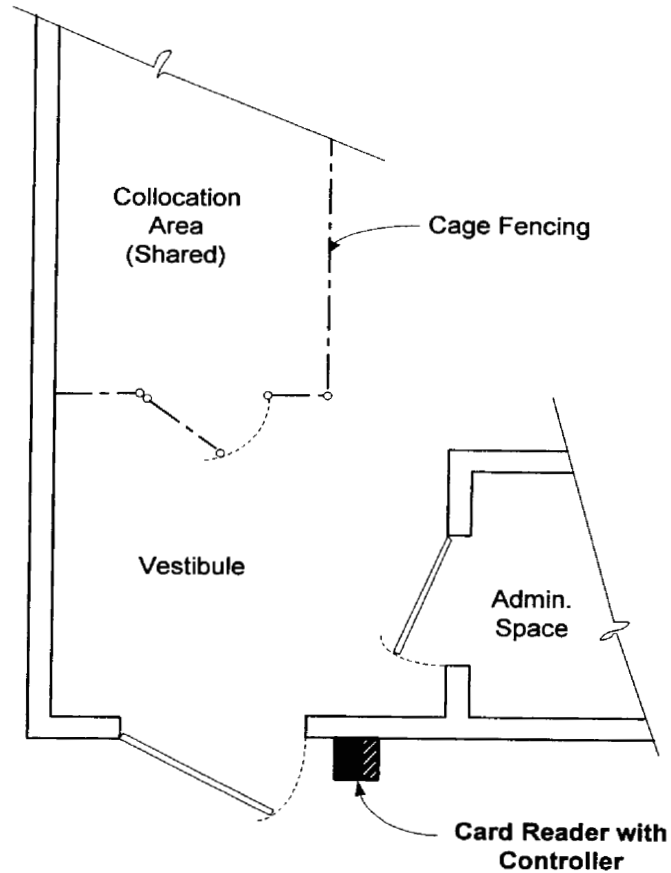

Note:  
This drawing is presented for illustrative purposes only. It presents one of many office layouts and construction alternatives. It is not intended as a contract document. Drawing is not to scale.

**Card Reader with Controller**

**Security Access**  
**Collocation Office Layout**

08/01/00 - c

**Collocation Drawing No. 10**

**Note:**  
 This drawing is presented for illustrative purposes only.  
 It presents one of many office layouts and construction  
 alternatives. It is not intended as a contract document.  
 Drawing is not to scale.

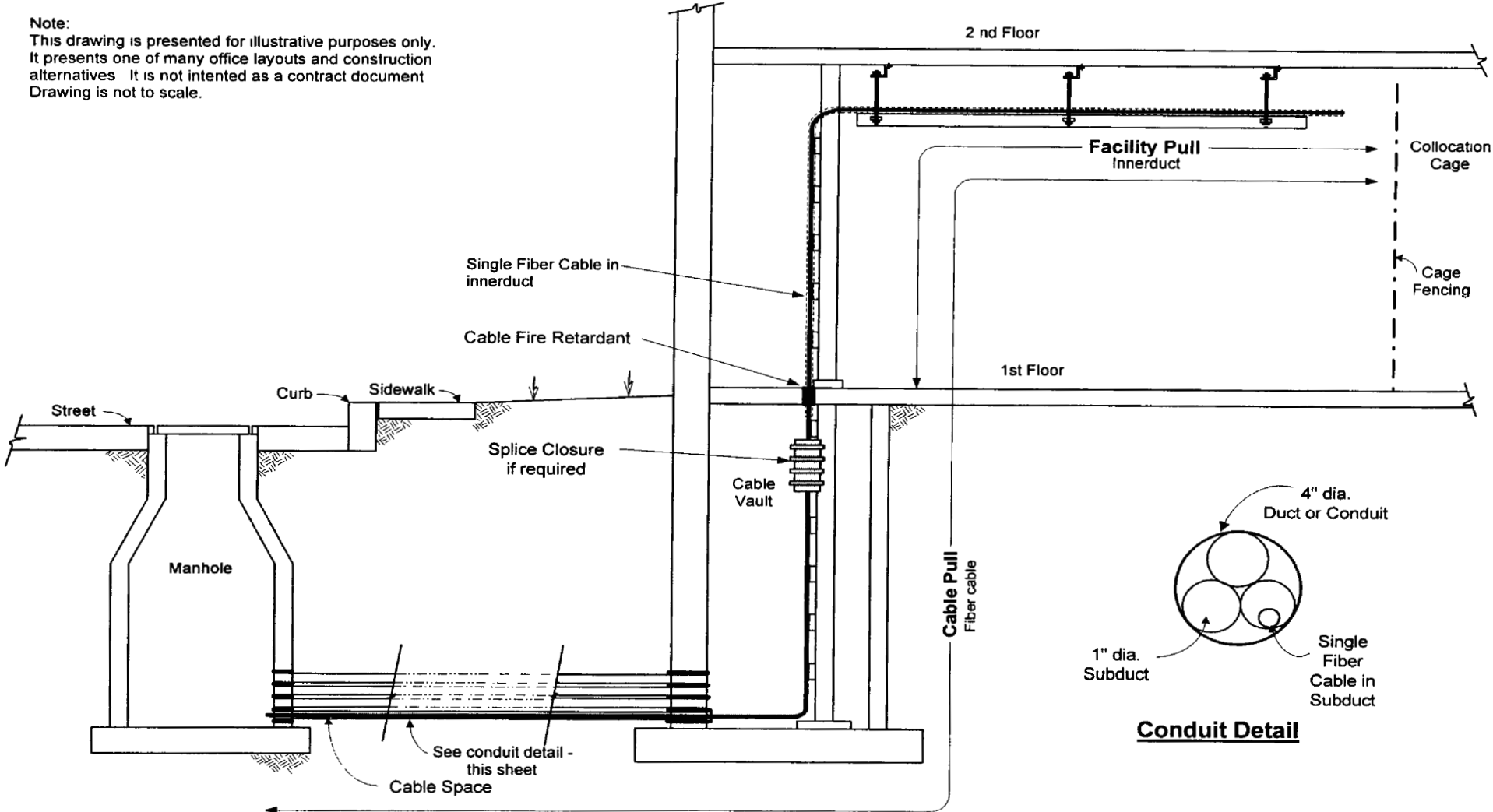

**Fiber - Cable Pull, Cable Facility & Cable Space**

**Collocation Office Layout**

08/01/00 - c

**Collocation Drawing No. 11**



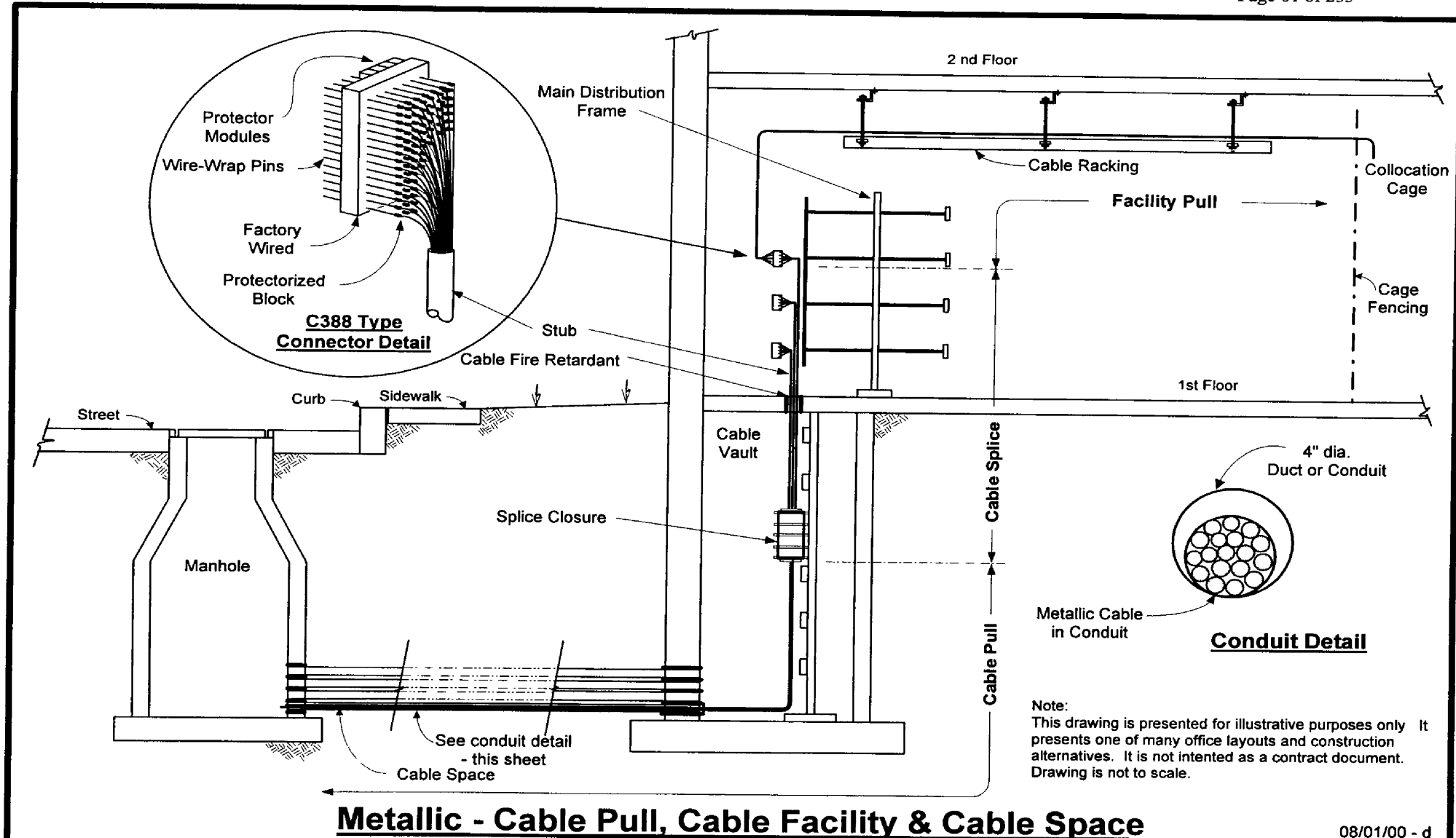

**Metallic - Cable Pull, Cable Facility & Cable Space**

Collocation Office Layout

Collocation Drawing No. 12

08/01/00 - d

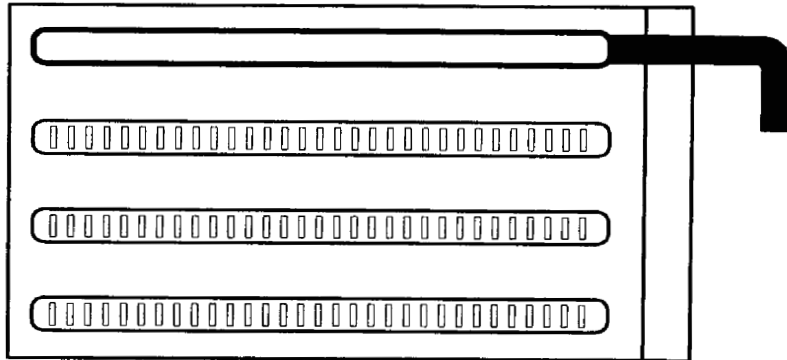

Top View

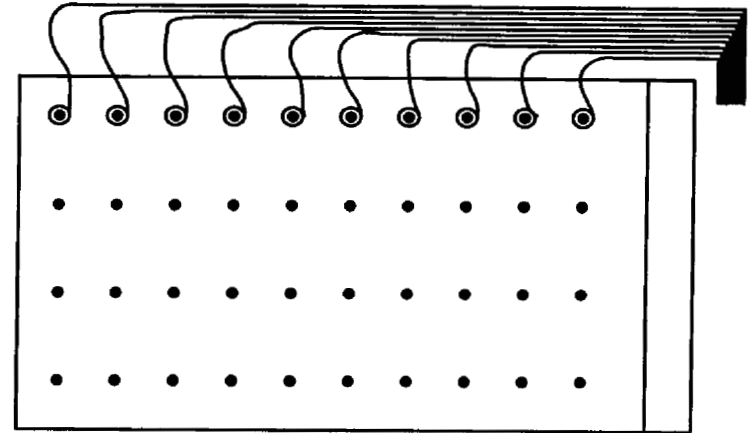

Top View

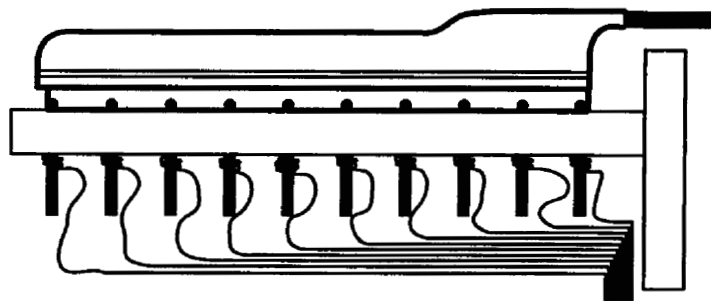

Side View

Connectorized

Wire-wrapped  
Connections

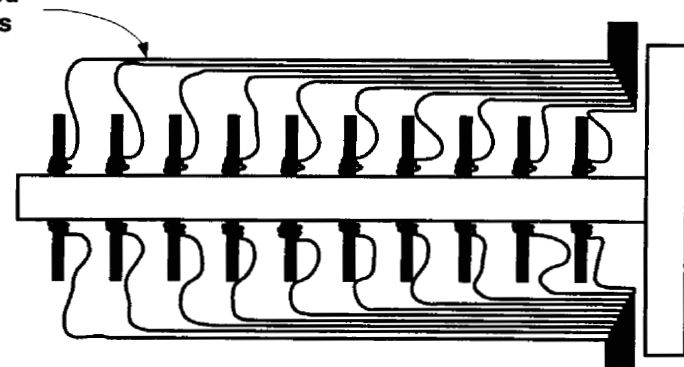

Side View

Unconnectorized

Note:  
 This drawing is presented for illustrative purposes only. It presents one of many office layouts and construction alternatives. It is not intended as a contract document. Drawing is not to scale.

Connectorized and Unconnectorized Connections

Collocation Office Layout

08/01/00 - b

Collocation Drawing No. 13

**Cable Racking Utilization**

Cable Racking Utilization is based on the cable capacity (number of cables) for a 24" wide cable rack for the following cable types:

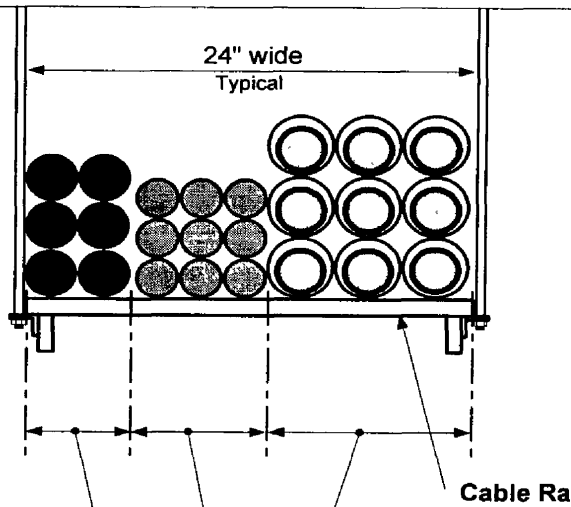

**Rack Capacity**

**Fiber Cable in innerduct:** Capacity based on innerduct encasing fiber cable.  
 145 Innerducts at 1.66" diameter each

**DS1 Metallic Cable:** 324 28-pair cables at .74" diameter each

**DSO Metallic Cable:** 200 100-pair cables at 1.20" diameter each

**Cable Vault Utilization**

- DS0 Metallic 1200 pr. Cable: 2.50" diameter each
- DS0 Metallic 900 pr. Cable: 2.38" diameter each
- DS0 Metallic 600 pr. Cable: 2.01" diameter each
- DS1 Metallic 100 pr. Cable: .96" diameter each
- Fiber Cable in Subduct: Subduct = 1.30" dia. each

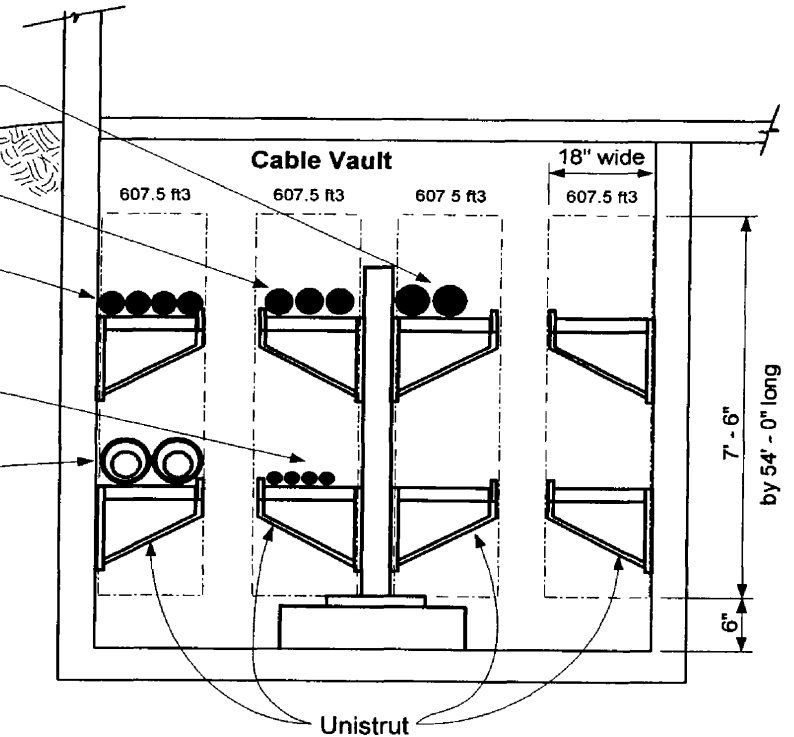

Note:  
 This drawing is presented for illustrative purposes only. It presents one of many office layouts and construction alternatives. It is not intended as a contract document. Drawing is not to scale.

**Utilization Factors**  
**Collocation Office Layout**

08/01/00 - b

**Collocation Drawing No. 14**

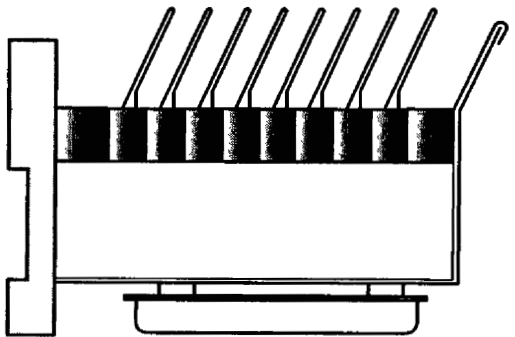

**DSO Telzon (CTB) Terminal Block**

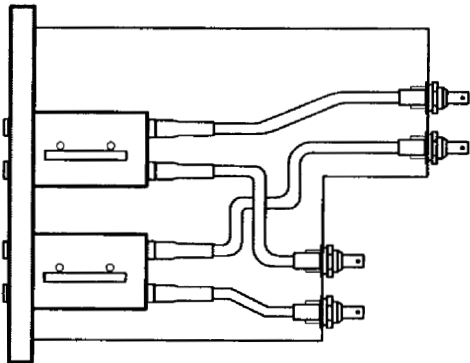

**DS3 Cross-Connect Panel**

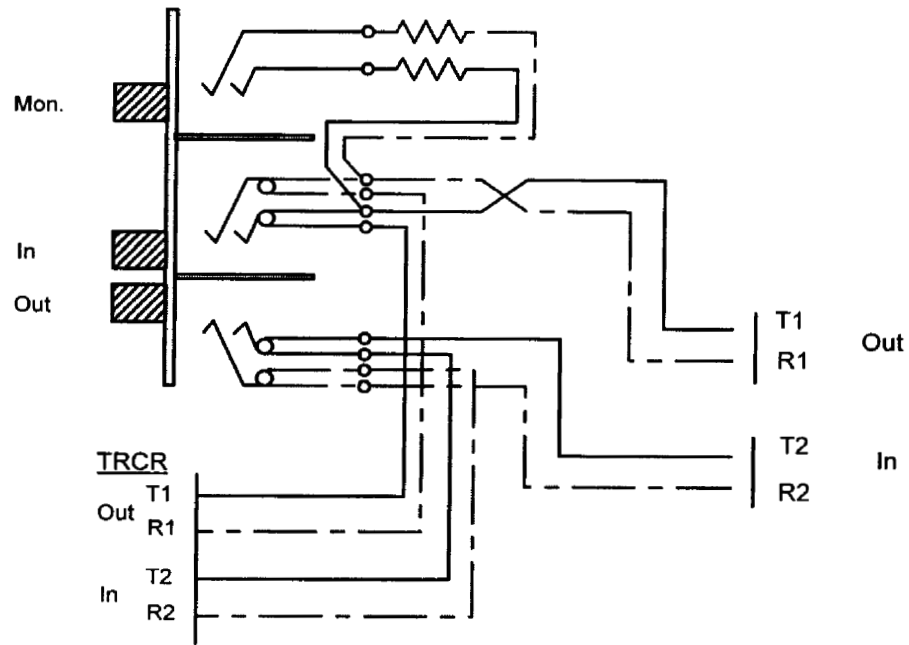

**DS1 Cross-Connect Panel**

Note:  
 This drawing is presented for illustrative purposes only. It presents one of many office layouts and construction alternatives. It is not intended as a contract document. Drawing is not to scale.

08/01/00 - b

**Cable Terminations**  
**Collocation Office Layout**

**Collocation Drawing No. 15**

Additional air conditioning loads will be incurred due to "heat-generating" collocation equipment, additional people and lights

Ventilation ducts is indicated by a dashed line and includes only minimal additional ductwork and diffusers.

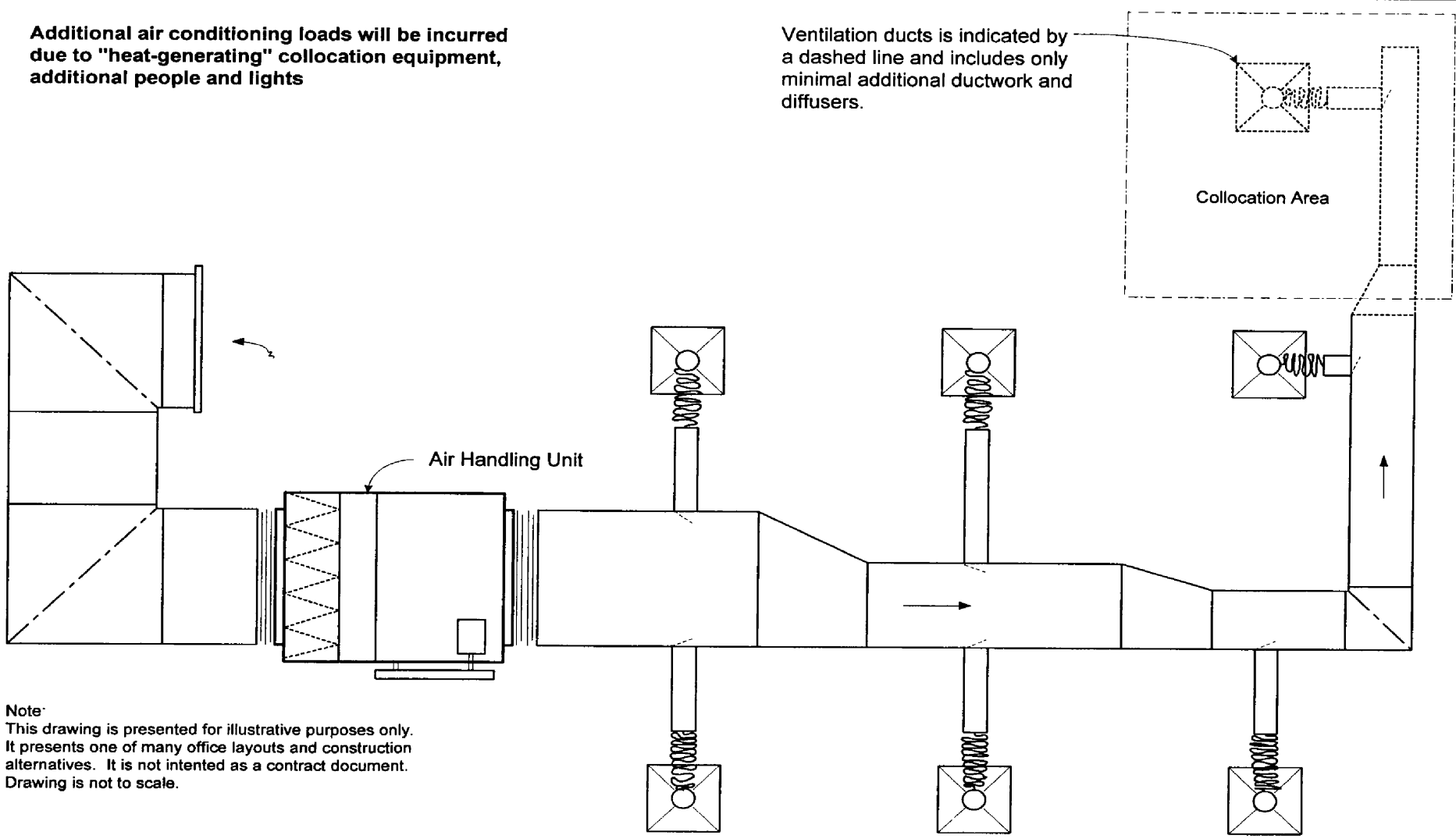

Note:  
This drawing is presented for illustrative purposes only.  
It presents one of many office layouts and construction alternatives. It is not intended as a contract document.  
Drawing is not to scale.

**Ventilation Ducts HVAC - Minor**  
**Collocation Office Layout**

08/01/00 - e  
**Collocation Drawing No. 16**

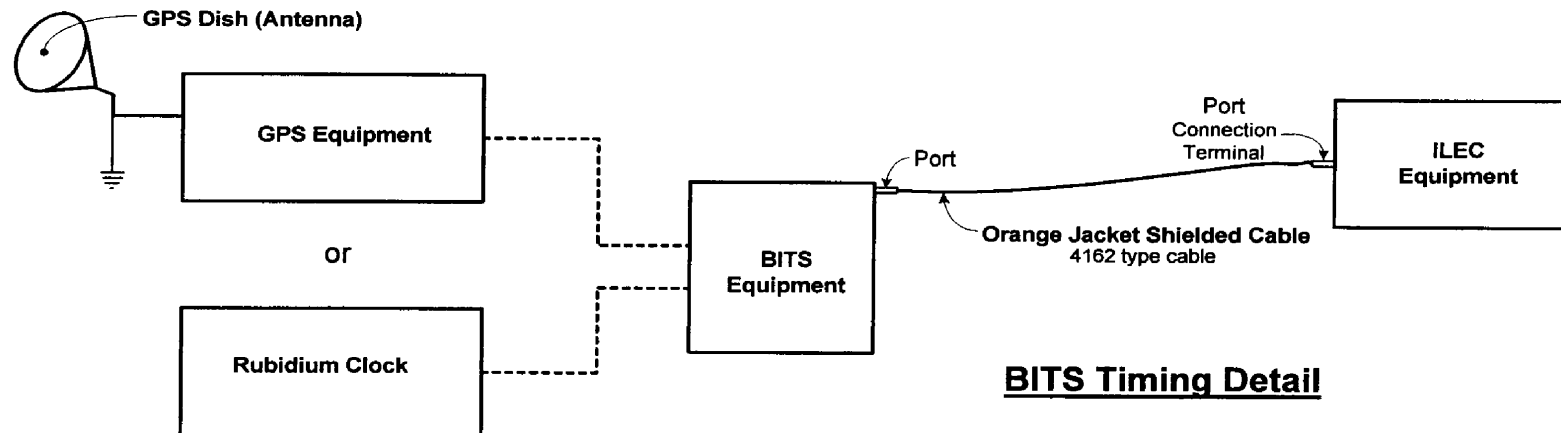

**BITS Timing Detail**

Note:  
This drawing is presented for illustrative purposes only. It presents one of many office layouts and construction alternatives. It is not intended as a contract document. Drawing is not to scale.

**BITS Timing**  
Collocation Office Layout

08/01/00 - b

**Collocation Drawing No. 17**

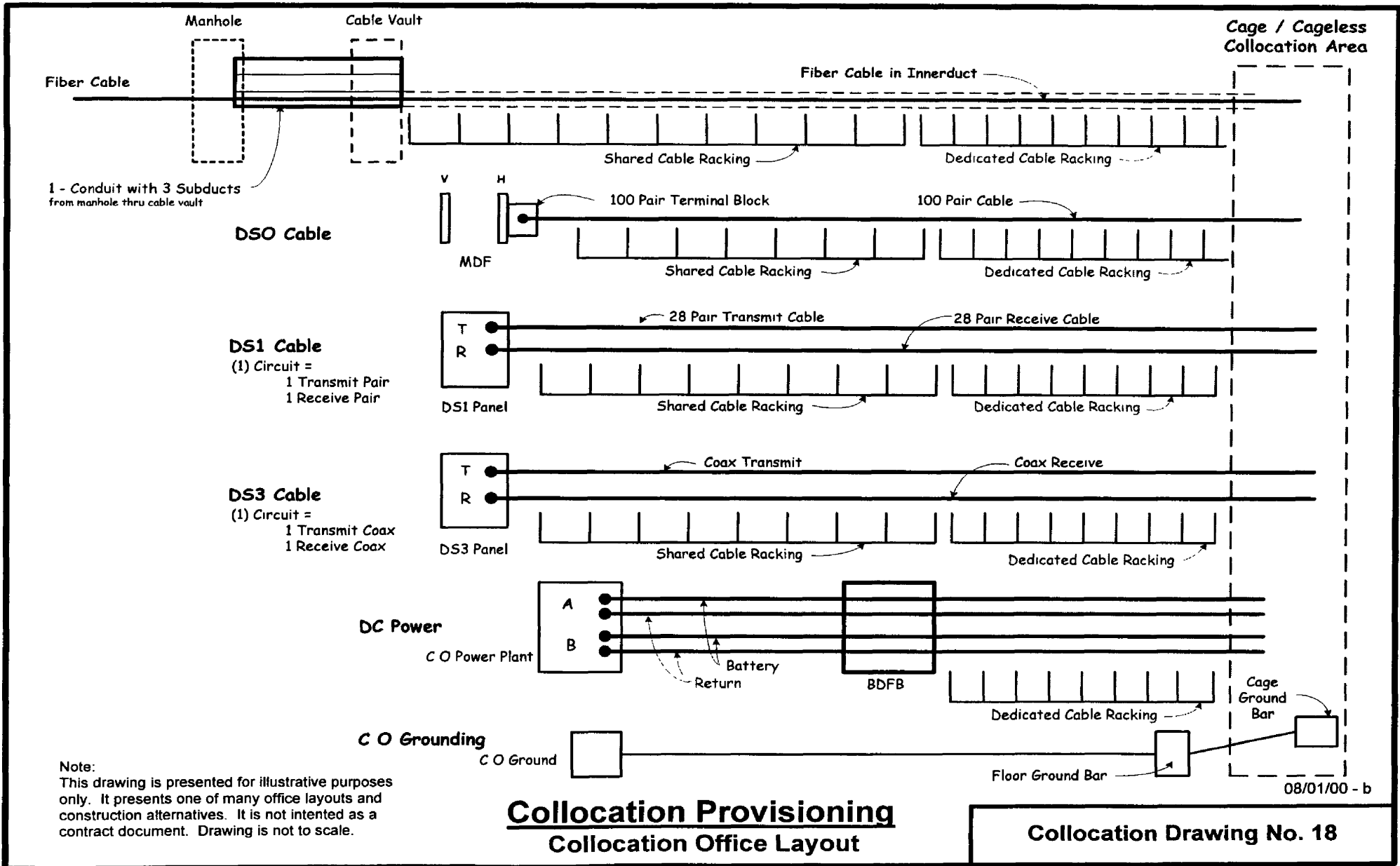

**Collocation Provisioning**  
**Collocation Office Layout**

**Collocation Drawing No. 18**

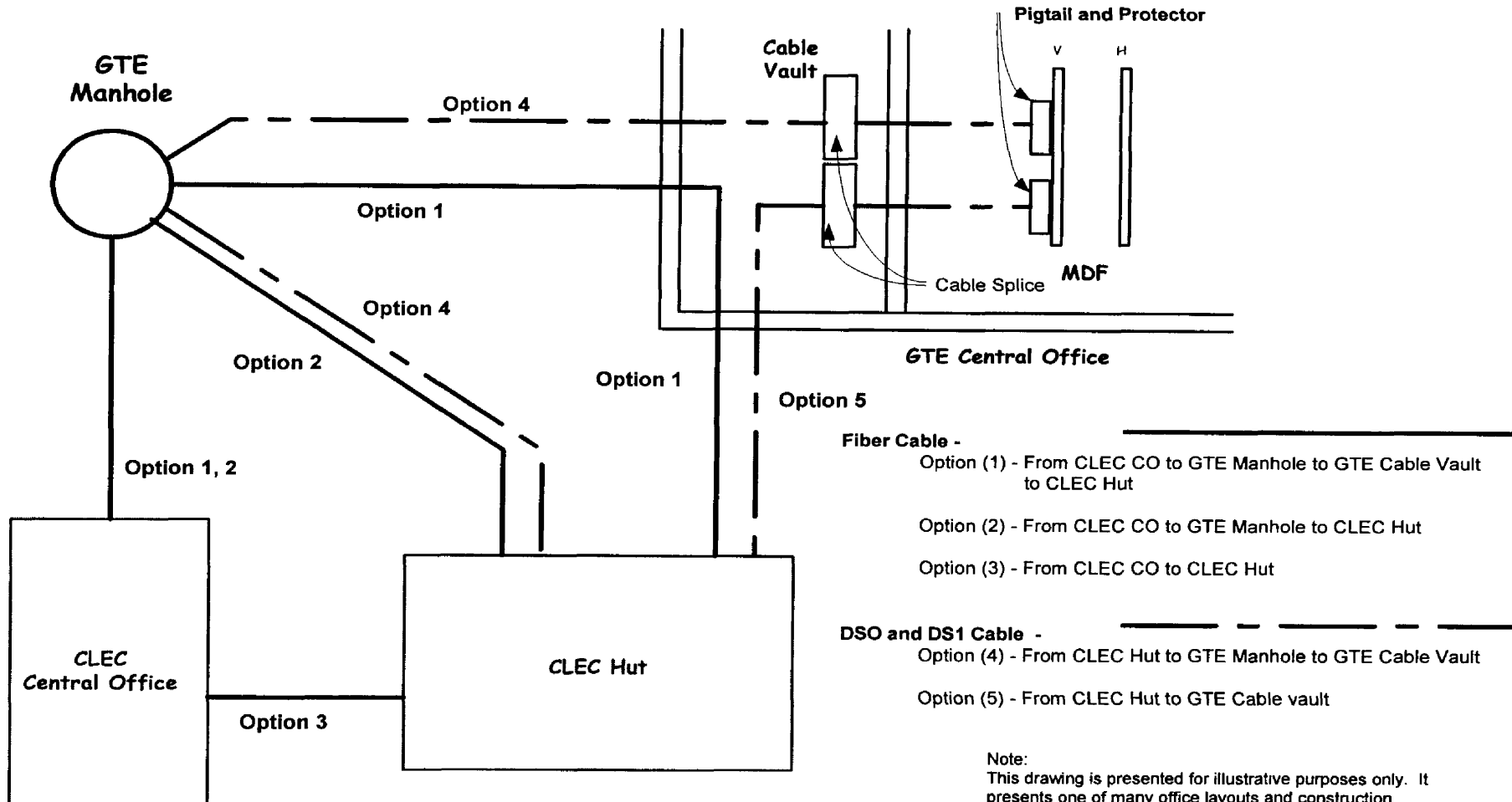

Note:  
 This drawing is presented for illustrative purposes only. It presents one of many office layouts and construction alternatives. It is not intended as a contract document. Drawing is not to scale.

**Adjacent On-Site Provisioning  
 Collocation Typical Office Layout**

02/20/00

**Collocation Drawing No. 19**



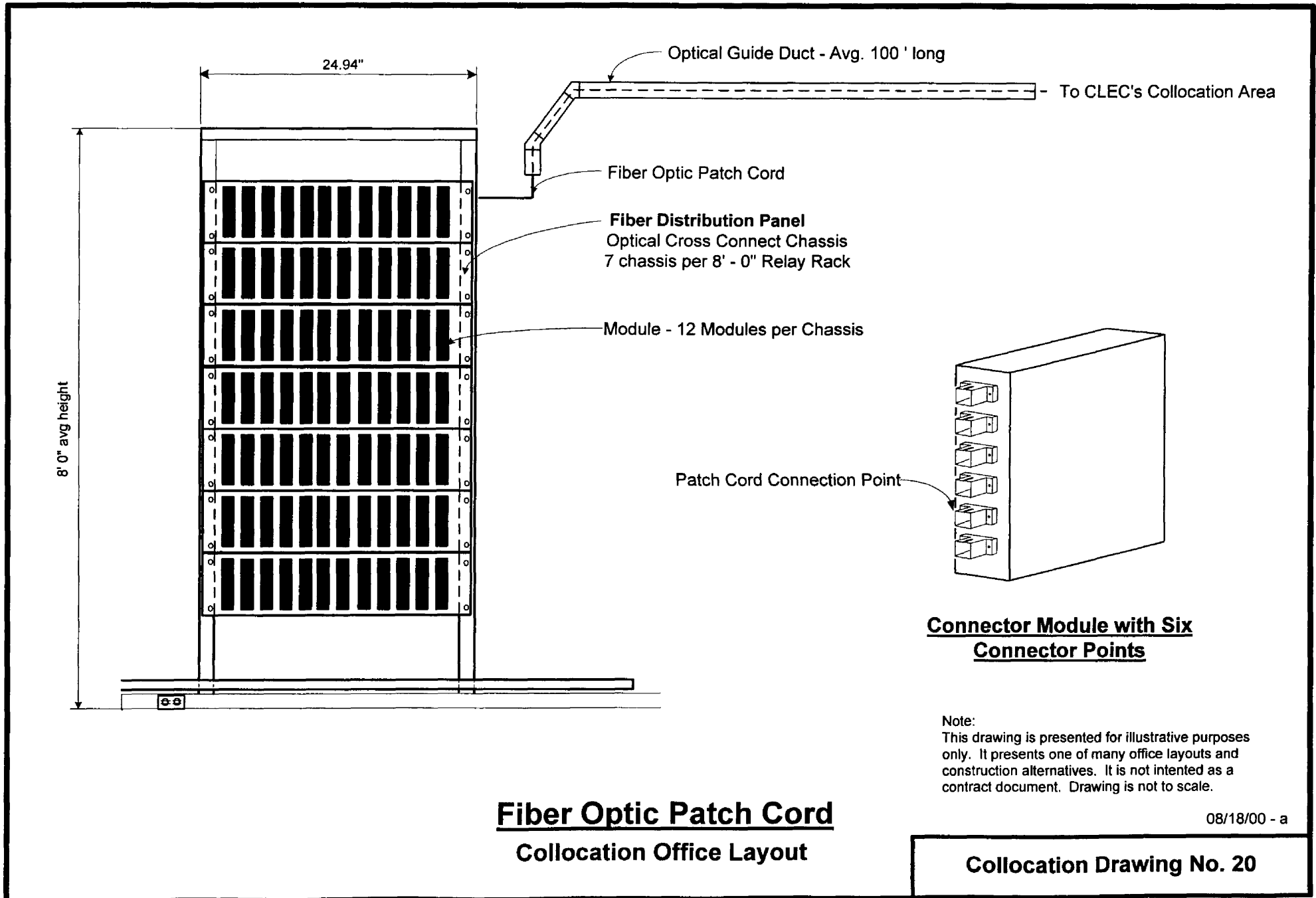

**Expanded Interconnection Services  
Glossary of Elements**

**NON-RECURRING CHARGES**

**(1) Engineering/Major Augment Fee – Caged/Cageless**

The Engineering/Major Augment Fee applies for each initial Caged or Cageless collocation request and major augment requests for existing Caged or Cageless collocation arrangements. This charge recovers the costs of the initial walkthrough to determine if there is sufficient collocation space, the best location for the collocation area, what building modifications are necessary to provide collocation, and if sufficient DC power facilities exist in the premises to accommodate collocation. This fee also includes the total time for the Building Services Engineer and the time for the Outside Plant and Central Office Engineers to attend status meetings. Major Augments are those requests that require power, add equipment that generates more BTUs of heat, or require an increase in the caged or cageless floor space, over what the ALEC requested in its original application. A complete application and Engineering Fee will be required when submitting a caged or cageless request that requires a major augment.

**(2) Minor Augment Fee**

The Minor Augment Fee applies for each minor augment request of an Existing Caged, Cageless, Virtual, or Microwave collocation arrangement that does not require additional power systems, HVAC system upgrades, or additional cage space.

**(3) Access Card Administration**

The Access Card Administration rate covers activities associated with the issuance and management of premises access cards. The rate is applied on a per card basis.

**(4-8) Cage Enclosure**

The Cage Enclosure rate is applied per caged arrangement. This rate includes the labor and materials to recover the costs incurred in constructing the ALEC's cage, cage gate, and grounding bar. There are five caged enclosure rate elements based on the size of the cage: 25 to 100 square feet; 101 to 200 square feet; 201 to 300 square feet; 301 to 400 square feet; and 401 to 500 square feet.

**Expanded Interconnection Services  
Glossary of Elements**

**(9) Cage Enclosure Augment**

The Cage Enclosure Augment rate is applied per square foot of fencing when a ALEC requests additional fencing for an existing caged arrangement.

**(10) Cage Grounding Bar**

The Cage Grounding Bar charge applies in situations where the ALEC makes arrangements to install its own cage enclosure. The charge applied per cage enclosure and recovers the material and labor costs to install the grounding bar, including necessary grounding wire.

**(11) Overhead Superstructure**

The Overhead Superstructure charge is applied for each initial caged and cageless collocation application. The Overhead Superstructure charge is designed to recover the Company's engineering, material, and installation costs for extending dedicated overhead superstructure.

**(12) Facility Pull – Engineering**

The Facility Pull Engineering charge is applied per project to recover the engineering costs of pulling metallic or fiber optic patchcord cables from the collocation cage or relay rack to the Main Distribution Frame block, DSX panel or fiber distribution panel. The charge would also apply per project to recover the engineering costs of pulling transmission cable from microwave antennae facilities on the rooftop to the collocation cage or relay rack.

**(13-14) Facility Pull – Labor**

The Facility Pull charge is applied per cable run and recovers the labor cost of pulling the metallic or fiber optic patchcord cables from the collocation cage or relay rack to the Main Distribution Frame block, DSX panel, or fiber distribution panel.

**(15) DSO Cable Termination (Connectorized)**

The DSO Cable Termination non-recurring charge is applied per 100 pair DSO cable terminated and is designed to recover the labor cost of

**Expanded Interconnection Services  
Glossary of Elements**

terminating preconnectorized DSO cable from the collocation cage or relay rack to the Main Distribution Frame block or DSX panel.

**(16) DS1 Cable Termination (Connectorized)**

The DS1 Cable Termination non-recurring charge is applied per 28 pair DS1 cable terminated and is designed to recover the labor cost of terminating preconnectorized DS1 cable from the collocation cage or relay rack to the DSX panel.

**(17) DS3 Coaxial Cable Termination (Preconnectorized)**

The DS3 Coaxial Cable Termination (Preconnectorized) non-recurring charge is applied per termination to recover the labor cost of terminating preconnectorized DS3 cable from the collocation cage or relay rack to the DSX panel.

**(18) DS3 Coaxial Cable Termination (Unconnectorized)**

The DS3 Coaxial Cable Termination (Unconnectorized) non-recurring charge is applied per termination to recover the labor cost of terminating unconnectorized DS3 cable from the collocation cage or relay rack to the DSX panel.

**(19) Category 5 Cable Termination (Connectorized)**

The Category 5 Cable Termination (Connectorized) non-recurring charge is applied per termination to recover the labor cost of terminating connectorized Category 5 cable from the collocation cage or relay rack to the DSX panel.

**(20) Fiber Optic Patchcord Termination**

The Fiber Optic Patch Cord Termination non-recurring cost includes the labor cost of terminating Fiber Optic Patch Cord cable from the collocation cage or relay rack to the designated Fiber Optic Distribution Panel. This fee is applied on a per termination basis.

**Expanded Interconnection Services  
Glossary of Elements**

**(21) Fiber Cable Pull-Engineering**

The Fiber Cable Pull-Engineering charge is applied per project to cover the engineering costs for pulling the ALEC's fiber cable, when necessary, into the Company's central office.

**(22) Fiber Cable Pull-Place Innerduct**

The Fiber Cable Pull-Place Innerduct charge is applied per linear foot to cover the cost of placing innerduct between the cable vault and the

collocation arrangement. Innerduct is the split plastic duct placed from the cable vault to the ALEC's equipment area through which the ALEC's fiber cable is pulled.

**(23) Fiber Cable Pull-Labor**

This charge is applied per linear foot and covers the labor costs of pulling the ALEC's fiber cable from the closest manhole (or equivalent) to the collocation arrangement.

**(24) Fiber Cable Pull-Cable Fire Retardant**

This charge is associated with the filling of space around cables extending through walls and between floors with a non-flammable material to prevent fire from spreading from one room or floor to another.

**(25) Fiber Cable Splice-Engineering**

The Fiber Splice-Engineering charge is applied per splicing project and covers the engineering costs for fiber cable splicing projects.

**(26) Fiber Cable Splice**

The Fiber Splice charge is applied per fiber cable strand and recovers the labor cost associated with the splicing.

**(27) DC Power-Engineering**

The DC Power-Engineering charge is applied per project for each caged, cageless, and virtual collocation application. This charge recovers the

**Expanded Interconnection Services  
Glossary of Elements**

Company's engineering costs for providing and terminating DC power runs to the collocation area.

**(28) DC Power Cable Pull/Termination**

The DC Power Cable Pull/Termination charge is applied per cable run for each caged, cageless, and virtual collocation application. This charge recovers the Company's installation costs for providing and terminating DC power runs to the collocation area.

**(29) DC Power Ground Wire**

The DC Power Ground Wire charge is applied per wire for each caged, cageless, and virtual collocation application. This charge recovers the Company's material costs for providing and terminating DC power runs to the collocation area.

**(30) Virtual Equipment Installation**

The Virtual Equipment Installation charge is applied on a per quarter rack (or quarter bay) basis and recovers the costs incurred by the Company for engineering and installation of the virtual collocation equipment. This charge would apply to the installation of powered equipment including but not limited to ATM, DSLAM, frame relay, routers, OC3, OC12, OC24, OC48, and NGDLC.

**(31) Virtual Software Upgrades**

The Virtual Software Upgrade is applied per base unit when the Company, upon ALEC request, installs software to upgrade equipment for an existing Virtual Collocation arrangement.

**(32) Virtual Card Installation**

The Virtual Card Installation charge is applied per card when the Company, upon ALEC request, installs additional cards for an existing Virtual Collocation arrangement.

**Expanded Interconnection Services  
Glossary of Elements**

**(33) Engineering/Major Augment Fee – Virtual**

The Engineering/Major Augment Fee applies for each initial Virtual collocation request and major augment requests for existing Virtual collocation arrangements. This charge recovers the costs of the initial walkthrough to determine if there is sufficient collocation space, the best location for the collocation area and if sufficient DC power facilities exist in the premises to accommodate collocation. This fee also includes the total time for the Building Services Engineer and the time for the Outside Plant and Central Office Engineers to attend status meetings.

Major Augments are those requests that require AC or DC power, add equipment that generates more BTUs of heat over what the ALEC requested in its original application. A complete application and Engineering Fee will be required when submitting a virtual collocation request that requires a major augment.

**MONTHLY RECURRING CHARGES**

**(34) Building Modification**

The Building Modification charge is applied to each caged and cageless arrangement and is associated with provisioning the following items in the Company's premises: security, dust partition, ventilation ducts, demolition/site work, lighting, outlets, and grounding equipment.

**(35) Environmental Conditioning**

The Environmental Conditioning charge is applied to each caged and cageless arrangement on a per 40 amp increment based on the ALEC's DC Power requirements. This charge is associated with the provisioning of heating, ventilation, and air conditioning systems for the ALEC's equipment in the Company's premises.

**(36) Caged Floor Space**

The Caged Floor Space is the cost per square foot to provide environmentally conditioned caged floor space to the ALEC. Environmentally conditioned space is that which has proper humidification and temperature controls to house telecommunications equipment. The

**Expanded Interconnection Services  
Glossary of Elements**

cost includes only that which relates directly to the land and building space itself.

**(37) Relay Rack Floor Space**

The Relay Rack Floor Space charge provides for the environmentally conditioned floor space that a relay rack occupies based on linear feet.

**(38) Cabinet Floor Space**

The Cabinet Floor Space charge provides for the environmentally conditioned floor space that a telecommunications equipment cabinet occupies based on linear feet.

**(39) Cable Subduct Space—Manhole**

This charge applies per subduct and recovers the cost of the space that the outside plant fiber occupies within the manhole.

**(40) Cable Subduct Space**

The Subduct Space charge covers the cost of the subduct space that the outside plant fiber occupies and applies on a per linear foot basis from the manhole (or equivalent) to the cable vault.

**(41-43) Fiber Cable Vault Splice and Space**

The Fiber Cable Vault Splice charge applies per fiber splice closure (i.e., per 48 and 96 fiber cable) and covers the material cost associated with the ALEC's fiber cable splice within the cable vault. The Fiber Cable Vault utilization monthly charge applies per subduct and covers the space that the ALEC's fiber cable utilizes in the cable vault.

**(44) Cable Rack Shared Space-Metallic**

The Cable Rack Space—Metallic charge is applied for each DSO, DS1, and DS3 cable run (e.g. from the cage or cageless arrangement to the Main Distribution Frame or equivalent). The charge is designed to recover the space utilization cost that the ALEC's metallic and coaxial cable occupies within the Company's cable rack system.



**Expanded Interconnection Services  
Glossary of Elements**

**(45) Cable Rack Shared Space-Fiber**

The Cable Rack Space-Fiber charge per innerduct foot recovers the space utilization cost that the ALEC's fiber cable occupies within the Company's cable rack system (e.g., from the vault to the cage or cageless arrangement; from the cage or cageless arrangement to the Fiber Distribution Panel).

**(46) DC Power**

The DC Power charge is applied on a per 40 amp (load) basis. This charge is designed to recover the monthly facility and utility expense to power the collocation equipment.

**(47) Facility Termination - DS0**

This charge is applied per 100 pair cable terminated. This charge is designed to recover the labor and material cost of the main distribution frame 100 pair circuit block.

**(48) Facility Termination - DS1**

The Facility Termination (DS1) charge is applied per 28 pair DS1 cable terminated. This charge is designed to recover the labor and material cost of the DSX facility termination panel.

**(49) Facility Termination - DS3**

The Facility Termination (DS3) charge is applied per DS3 cable terminated. This charge recovers the labor and material cost of the DSX facility termination panel.

**(50) Virtual Equipment Maintenance**

The Virtual Equipment Maintenance charge is applied on a per quarter rack (or bay) basis and recovers the costs incurred by the Company for maintenance of the ALEC's virtual collocation equipment. This charge would apply to the maintenance of equipment including, but not limited to, ATM, DSLAM, frame relay, routers, OC3, OC12, OC24, OC48 and NGDLC.

**Expanded Interconnection Services  
Glossary of Elements**

**ADJACENT NON-RECURRING CHARGES**

**(51) Adjacent-Engineering Fee**

The Adjacent Engineering Fee provides for the initial activities of the Central Office Equipment Engineer, Land & Building Engineer and the Outside Plant Engineer associated with determining the capabilities of providing Adjacent On-Site collocation. The labor charges are for an on-site visit, preliminary investigation of the manhole/conduit systems, wire center and property, and contacting other agencies that could impact the provisioning of adjacent collocation.

**(52) Adjacent Metallic Facility Pull-Engineering**

This charge covers the engineering cost associated with the interconnection wire (cable) from the main distribution frame connector to a termination block or DSX panel.

**(53) Adjacent Metallic Facility Pull - Labor**

This charge covers the labor of running the interconnection wire (cable) from the main distribution frame connector to a termination block or DSX panel.

**(54-55) Adjacent DS0 Cable Termination (Connectorized)/Adjacent DS0  
Cable Termination (Unconnectorized)**

These charges cover the labor to terminate these types of interconnection wire (cable) for adjacent collocation to the main distribution frame block or equivalent.

**(56-57) Adjacent DS1 Cable Termination (Connectorized)/Adjacent DS1  
Cable Termination (Unconnectorized)**

These charges cover the labor of terminating these types of interconnection wire (cable) for adjacent collocation to the DSX panel.

**Expanded Interconnection Services  
Glossary of Elements**

**(58-59) Adjacent DS3 Coaxial Cable Termination (Preconnectorized)/  
Adjacent DS3 Coaxial Cable Termination (Unconnectorized)**

These charges cover the labor of terminating this type of interconnection wire (cable) for adjacent collocation to the DSX panel.

**(60) Adjacent Category 5 Cable Termination (Connectorized)**

These charges cover the labor cost of terminating this type of interconnection wire (cable) for adjacent collocation to the DSX panel

**(61) Adjacent Fiber Cable Termination**

This charge covers the labor of terminating fiber cable, per fiber strand, for adjacent collocation to the fiber distribution panel.

**(62) Adjacent Fiber Cable Pull-Engineering**

The Adjacent Fiber Cable Pull-Engineering fee provides for engineering associated with pulling the ALEC's fiber cable in an adjacent collocation arrangement. The Adjacent Fiber Cable Pull-Engineering charge includes the time incurred by the Outside Plant Engineer on the project to determine the conduit/subduct assignment and associated outside plant activity to complete the work.

**(63) Adjacent Fiber Cable Pull-Place Innerduct**

This charge covers the cost for innerduct on a per linear foot basis from the cable vault to the ALEC's equipment area through which the ALEC's fiber is pulled.

**(64) Adjacent Fiber Cable Pull - Labor**

This charge covers the labor costs for pulling ALEC fiber cable for an adjacent collocation arrangement. Refer to Adjacent Fiber Cable Pull-Engineering above.

**Expanded Interconnection Services  
Glossary of Elements**

**(65) Adjacent-Cable Fire Retardant**

This charge is associated with the filling of space around cables extending through walls and between floors with a non-flammable material to prevent fire from spreading from one room or floor to another.

**(66) Adjacent Metallic Cable Pull-Engineering**

This charge covers the engineering costs of pulling metallic cable for Adjacent collocation into the Company wire center. For Adjacent collocation, the metallic cable will be spliced in the cable vault to a stubbed connector located on the vertical side of the main distribution frame to provide proper protection for central office equipment.

**(67) Adjacent Metallic Cable Pull - Labor**

This charge per linear foot covers the labor costs of pulling metallic cable for Adjacent collocation into the Company wire center.

**(68) Adjacent Metallic Cable Splice-Engineering**

This charge covers the outside plant engineering costs for cable splice projects associated with an Adjacent collocation arrangement.

**(69) Adjacent Metallic Cable Splicing (greater than 200 pair)**

This charge is for the labor to splice metallic cables and is based on a per pair spliced.

**(70) Adjacent Metallic Cable Splicing (less than 200 pair)**

This charge is for the labor to splice metallic cables and is based on a per pair spliced.

**(71) Adjacent Fiber Cable Splicing-Engineering**

This charge covers the outside plant engineering costs for cable splice projects associated with an Adjacent collocation arrangement.

**Expanded Interconnection Services  
Glossary of Elements**

**(72) Adjacent Fiber Cable Splicing (48 fiber cable or less)**

This charge per fiber strand covers the labor to splice fiber cables.

**(73) Adjacent Fiber Cable Splice (greater than 48 fiber)**

This charge per fiber stand covers the labor to splice fiber cables.

**ADJACENT MONTHLY RECURRING CHARGES**

**(74) Adjacent Subduct Space–Manhole**

This charge per subduct covers the space utilization cost that the outside plant fiber cable occupies within the manhole.

**(75) Adjacent Subduct Space**

This charge per linear foot covers the space utilization cost of the subduct that the outside plant fiber cable occupies within the conduit system.

**(76) Adjacent Conduit Space (4” Duct)-Metallic-Manhole**

This charge covers the space utilization cost that the outside plant metallic cable occupies within the manhole.

**(77) Adjacent Conduit Space (4” Duct)-Metallic Cable**

This charge covers the space utilization cost that the outside plant metallic cable occupies within the conduit system.

**(78) Adjacent Facility Termination DS0 Cable-Material**

This charge is applied per 100 pair cable terminated. This charge is designed to recover the labor and material cost of the main distribution frame 100 pair circuit block.

**(79) Adjacent Facility Termination DS1 Cable-Material**

The Facility Termination (DS1) charge is applied per 28 pair DS1 cable terminated. This charge is designed to recover the labor and material cost of the DSX facility termination panel.

**Expanded Interconnection Services  
Glossary of Elements**

**(80) Adjacent Facility Termination DS3 Cable-Material**

The Facility Termination (DS3) charge is applied per DS3 cable terminated. This charge recovers the labor and material cost of the DSX facility termination panel.

**(81-91) Adjacent Cable Vault Splice and Space**

The Adjacent Cable Vault Splice applies per splice enclosure (e.g., per 1200 pair cable) and covers the cost associated with the ALEC's cable splice closure within the cable vault. The Adjacent Cable Vault Space charge applies per cable for metallic cable and per subduct for fiber cable, and covers the space that the ALEC's cable utilizes in the cable vault.

**(92-95) Adjacent Cable Rack Shared-Space**

This charges cover the space utilization cost that the ALEC's fiber, metallic or coaxial cables occupies within the cable rack system. The charge is based on the linear feet occupied.

**MISCELLANEOUS NON-RECURRING CHARGES**

**(96) BITS Timing**

The charge for BITS Timing includes engineering, materials, and labor costs to wire a BITS port to the ALEC's equipment. If requested, it is applied on a per project basis.

**(97) Collocation Premise Space Report - Optional**

When requested by a ALEC, the Company will submit a report that indicates the Company's available collocation space in particular premises. The report will be issued within ten calendar days of the request. The report will specify the amount of collocation space available at each requested premises, the number of collocators and any modifications in the use of the space since the last report. The report will also include measures that the Company is taking to make additional space available for collocation.

**Expanded Interconnection Services  
Glossary of Elements**

**(98) Engineering/Major Augment Fee – Microwave**

The Engineering for Microwave Collocation applies when an existing Caged and Cageless collocation arrangement is augmented with newly installed microwave antennae and other exterior facilities. This charge recovers the costs of the initial walkthrough to determine if there is sufficient space, the best location for the microwave antennae and other exterior facilities, what building modifications are necessary, if any, and if sufficient support facilities exist in the premises to accommodate the microwave antennae and other exterior facilities. This fee also includes the total time for the Building Services Engineer to coordinate the entire project.

**(99) Facility Pull (Microwave) - Labor**

The charge applies on a per linear foot basis to recover the facility pull costs of pulling transmission cable from microwave antennae facilities on the rooftop to the collocation cage or relay rack for microwave collocation arrangements.

**(100-111) Cable Material Charges**

The ALEC has the option of providing its own cable or the Company may, at the ALEC's request, provide the necessary transmission and power cables. If the Company provides these cables, the applicable Cable Material Charge will be charged.

**(112-117) Miscellaneous Services-Labor**

These Miscellaneous Service-Labor non-recurring charges cover the additional cost of labor, if required by the ALEC, to complete a collocation request.

**MISCELLANEOUS MONTHLY RECURRING CHARGES**

**(118) Microwave Rooftop Space**

Microwave Rooftop Space is the cost per square foot to provide rooftop space to the ALEC for microwave antennae and other exterior facilities. The cost includes only that which relates directly to the land and building space itself.

**Expanded Interconnection Services  
Glossary of Elements**

**(119) BITS Timing**

The BITS Timing monthly charge per port is designed to recover the equipment and installation cost of provide synchronized timing for electronic communications equipment.

**(120) Facility Termination – Fiber Optic Patchcord**

The Facility Termination (Optical) charge is applied per optical connector terminated. This charge recovers the labor and material cost of the optical termination.

**(121) Cable Duct Space - Fiber Optic Patchcord**

The Cable Duct Space (Optical) charge is applied per fiber strand. This charge is for the material, engineering and installation cost for the fiber guide duct system material used to protect, support and route the fiber patch cord between the collocators equipment and the Verizon's designated collocators Fiber Distribution Panel.

**ICBs for Microwave Collocation**

**(122) Building Penetration for Cable**

The reasonable costs to penetrate buildings for microwave cable to connect microwave antennae facilities and other exterior facilities to the transmission equipment in the collocation cage or relay rack will be determined and applied on an individual case basis, where technically feasible, as determined by the initial and subsequent Engineering surveys.

**(123) Special Work**

The costs incurred by the Company for installation of ALEC's microwave antennae and other exterior facilities that are not recovered via other microwave rate elements will be determined and applied on an individual case basis.



**Expanded Interconnection Services  
Glossary of Elements**

**DEDICATED TRANSIT SERVICE NON-RECURRING CHARGES**

**(124, 132, 141) Service Order-Semi-Mechanized**

The Service Order-Semi-mechanized rate is applied per DTS order to the requesting ALEC for the recovery of DTS order placement and issuance costs when the semi-mechanized ordering interface is utilized.

**(125, 133, 142) Service Order-Manual**

The Service Order-Manual rate is applied per DTS order to the requesting ALEC for the recovery of DTS order placement and issuance costs when the semi-mechanized ordering interface is not utilized.

**(126, 134-135, 143) Service Connection-CO Wiring**

The Service Connection-CO Wiring rate is applied per DTS circuit to the requesting ALEC for recovery of DTS jumper material, wiring, and service turn-up for DS0, DS1, DS3 and dark fiber circuits.

**(128-131,137-140,145-148) Service Order/Service Connection-Disconnect**

The Service Order-Disconnect and Service Connection-Disconnect rates are applied per DTS order or circuit, as necessary, to the requesting ALEC for the recovery of DTS disconnect costs for DS0, DS1, DS3 and dark fiber.

**(127, 136, 144) Service Connection-Provisioning**

The Service Connection-Provisioning rate is applied per DTS order to the requesting ALEC for recovery of circuit design and labor costs associated with the provisioning of DS0, DS1, DS3 and dark fiber circuits for DTS.

# Expanded Interconnection Services Cost Study Acronyms

## A

AC	Alternating Current
ACF	Annual Cost Factors
ACTL	Access Carrier Location (CLLI)
AMPS	Asset Management Property Systems
amps	Amperage
ASR	Access Service Request

## B

BDFB	Battery Distribution Fuse Bay
BITS	Building Integrated Timing System
BRPC	Business Response Provisioning Center
BZT	Business Zone Technician

## C

CC	Composite Clock
CKT	Circuit
CLEC	Competitive Local Exchange Carrier
CO	Central Office
COE	Central Office Equipment
COEI	Central Office Equipment Installation
CPE	Customer Premise Equipment
CPMS	Capital Programs Management System
CZT	Customer Zone Technician

## D

DC	Direct Current
DSX	Digital Signal Cross-connect

## E

EIS	Expanded Interconnection Service
-----	----------------------------------

**Expanded  
Interconnection  
Services  
Cost Study  
Acronyms**

**F**

FCC Federal Communications Commission  
FOT Fiber Option Terminal

**G**

GC Guest Collocator  
GTEAMS GTE Advanced Materials Systems

**H**

HC Host Collocator  
HPU Hours Per Unit  
HVAC Heating, Ventilation and Air Conditioning

**I**

IC Interconnect Company (IXC)  
ICB Individual Case Basis  
ICM Incremental Costing Model  
ILEC Incumbent Local Exchange Carrier  
IXC Interexchange Carrier (IC)

**J**

**K**

kw Kilowatts  
kwh Kilowatt Hour

**L**

L&B Land and Buildings  
LEC Local Exchange Carrier  
Lin ft Linear Feet

**Expanded  
Interconnection  
Services  
Cost Study  
Acronyms**

**M**

---

MDF	Main distribution Frame
mh	Manhole
MRC	Monthly Recurring Cost
MCM	Thousand Circular Mils

**N**

---

NACC	National Access Contact Center
"N" ASR	New - Access Service Request
NOMC	National Open Market Center
NRC	Non-recurring Cost

**O**

---

OMT	Open Market Transition
OSP	Outside Plant

**P**

---

POTS	Plain Old Telephone Service
PRS	Primary Reference Source
PUC	Public Utilities Commission

**Q**

---

**R**

---

RIT	Regional Implementation Team
-----	------------------------------

**S**

---

SME	Subject Matter Expert
sf	Square Foot
sq ft	Square Foot
SSP	Single Source Provider
SWB	Switchboard

**Expanded  
Interconnection  
Services  
Cost Study  
Acronyms**

T

TBL Trouble  
TELRIC Total Element Long Run Incremental Cost  
TSG Timing Signal Generator  
TSLRIC Total Service Long Run Incremental Cost

U

UC Unconnectorized

V

W

WM Wholesale Markets

X, Y, Z

Verizon Expanded Interconnection Services  
**Workpapers**

Florida  
Section 2

Table of Contents

	Page
<b>Non-recurring Rates</b>	
Engineering	90
Access Card Administration	94
Cage Enclosure	96
Cage Grounding Bar	104
Overhead Superstructure	106
Facility Pull	109
Fiber Cable Pull	115
Fiber Cable Splice	117
DC Power Cable	119
Cable Material	120
Virtual Equipment Installation	122
Vitual Software Upgrades	125
Virtual Card Installation	128
Virtual Engineering	131
BITS Timing	133
Engineering - Adjacent On-Site	135
On-Site Facility Pull	136

Verizon Expanded Interconnection Services  
**Workpapers**

Florida  
Section 2

Table of Contents

	Page
<b>Non-recurring Rates</b>	
On-Site Cable Termination	137
On-Site Cable Pull	138
On-Site Cable Splice	139
Premise Space Reports	143
Labor	145
Relay Rack	146
Telecommunications Equipment Cabinet	148

Verizon Expanded Interconnection Services  
**Workpapers**

Florida  
Section 2

Table of Contents

	Page
<b>Monthly Recurring Rates</b>	
Building Modification	150
Environmental Conditioning	157
Floor Space	162
Cable Space	168
Fiber Cable Vault Splice	172
Cable Vault Space	180
Cable Rack Shared Space	188
DC Power	192
Facility Termination	201
BITS Timing	208
Facility Termination - Fiber Optic Patch Cord	211
Cable Duct Space - Fiber Optic Patch Cord	213
Virtual Equipment Maintenance and Frame Space	218
On-Site Cable Space	224
On-Site Facility Termination	226
On-Site Cable Vault Splice	227
On-Site Cable Rack Shared Space	228



**Verizon: EIS Study - Florida**  
**Non-recurring Rate Development**  
**Engineering/Major Augment - Caged/Cageless**

Ln	Cost Elements	Increment	Source	Cost (a)	Frequency (b)	Units (c)	Subtotal (d) = (a)*(b)*(c)
<b>Engineering Costs</b>							
1	Initial Central Office Collocation Site	per occurrence	Engineering-CS	\$ 1,584.46	29%	1	\$ 459.49
2	Additional Central Office Collocation Site	per occurrence	Engineering-CS	\$ 1,296.84	71%	1	\$ 920.76
3	<b>Non-recurring Cost per Unit</b>		Sum(Ln 1.. Ln 2)				<u>\$ 1,380.25</u>
4	<b>Rate Element</b>		Ln 3				<u><u>\$ 1,380.25</u></u>

Note:  
 The frequencies for the Engineering/Major Augment Fee NRC are the number of initial collocation applications for a given central office (29%) and the number of applications in central offices where collocation applications have been already received (71%). These percentages are applied to the "Initial" and "Additional" cost elements in order to derive one rate.

**Verizon: EIS Study - Florida**  
**Non-recurring Rate Development**  
**Minor Augment**

<b>Ln</b>	<b>Cost Elements</b>	<b>Increment</b>	<b>Source</b>	<b>Cost</b>	<b>Units</b>	<b>Subtotal</b>
				(a)	(b)	(c) = (a)*(b)
<b>Engineering Costs</b>						
1	Minor Augment Fee	per occurrence	Engineering-CS	\$ 256.69	1	\$ 256.69
2	<b>Non-recurring Cost per Unit</b>		Ln 1			<u>\$ 256.69</u>
3	<b>Rate Element</b>		Ln 2			<u><u>\$ 256.69</u></u>

**Verizon: EIS Study - Florida**  
**Non-recurring Rate Development**  
**Engineering/Major Augment - Microwave**

Ln	Cost Elements	Increment	Source	Cost (a)
1	Microwave Only	per occurrence	Engineering-CS	<u>1,091.17</u>
2	<b>Non-recurring Cost per Unit</b>		Ln 1	<u>1,091.17</u>
3	<b>Rate Element</b>		Ln 2	<u><u>1,091.17</u></u>

**Verizon: EIS Study - Florida**  
**Non-recurring Cost Development**  
**Engineering**

Description	Loaded Labor Rate A = LLR-1	Engineering/Major Augment				Minor Augment		Microwave Collocation Site	
		Initial C.O. Collocation Site <sup>1</sup>		Additional C.O. Collocation Sites or Major Augment to Current site <sup>2</sup>		Minor Augmentation to Current Service Arrangements <sup>3</sup>		Microwave Collocation Site	
		Initial Site Hours B	Initial Site Cost C = A * B	Additional or Major Augment Site Hours D	Additional or Major Augment Site Cost E = A * D	Change Site Hours F	Change Site Cost G = A * F	Microwave Site Hours H	Microwave Site Cost I = A * H
<b>Pre-Acceptance (Internal Site Audit)</b> (Review of CO on initial application from collocator)									
Building Engineer CO Equipment Engineer									
<b>Post-Acceptance</b> (Collocators final decision to collocate in a specific CO)									
Building Engineer Engineers time to oversee construction									
CO Equipment Engineer Engineers time for Kick-Off Meeting Engineers time for 3 - 30 min. status meetings Engineers time for 1- 30 min. status meetings									
Outside Plant Engineering Engineers time for Kick-Off Meeting Engineers time for 3 - 30 min. status meetings Engineers time for 1 - 30 min. status meetings									
<b>Total Cost</b>		\$	1,584.46	\$	1,296.84	\$	256.69	\$	1,091.17

Notes.

- 1) "Initial" site represents a CO in which no previous collocation has taken place.
- 2) "Major Augment" represents a physical change or modification to an existing collocation site, remodel, expansion, add OSP cable, DC Power or additional new collocator.  
"Additional CO Collocation" site represents a new site at a CO with existing collocation.
- 3) "Minor Augmentation" is a change in current service provisioning for a specific collocator within the central office, specific to blocks, panels, intra-office cables.

Highlighted information is redacted for reason #2. Parties may obtain this information by signing a non-disclosure agreement.

Verizon: EIS Study - Florida  
 Non-recurring Rate Development  
 Access Card Administration

Docket No. 981834-TP/990321-TP  
 Direct Testimony of Barbara K. Ellis  
 Exhibit BKE-1  
 FPSC Exhibit \_\_\_\_\_  
 Page 94 of 235

Ln	Cost Elements	Increment	Source	Cost (a)	Units (b)	Subtotal (c) = (a) * (b)
<b>Access Card Administration</b>						
1	New/Replacement	per card	Access Card Admin-CS	\$ 27.75	1	\$ 27.75
2	Change	per card	Access Card Admin-CS	\$ 3.89	1	\$ 3.89
3	<b>Non-recurring Cost per Unit</b>		Ln 1			<u>\$ 31.64</u>
4	<b>Rate Element</b>		Ln 2			<u><u>\$ 31.64</u></u>

Verizon: EIS Study - Florida  
 Non-recurring Cost Development  
 Access Card Administration

<b>New/Replacement Processing Time Tasks</b>	<b>Process Time (min)</b>	<b>Hours</b>	<b>Loaded Labor Rate</b>	<b>Cost Per Card</b>	<b>Probability</b>	<b>Cost</b>
Request for Card						
Order cards/site						
Receipt for card						
Program card						
Program controller						
Ship CLEC card to Whls Mkts						
Call CLEC/Issue card						
Wholesale Markets Admin						
Ship Sheet to Security						
Receive/Log in/out/file						
	<b>Total</b>					
<b>Cards</b>						<b>Cost</b>
Card - each						
Card - Shipping Charges						
	<b>Total</b>					
<b>Total New/Replacement Cost</b>						<b>\$ 27.75</b>
<b>Change/Add/Del Sites</b>	<b>Process Time (min)</b>	<b>Convert to Hrs.</b>	<b>Loaded Labor Rate</b>	<b>Cost Per Card</b>	<b>Probability</b>	<b>Cost</b>
Request to Wholesale Markets						
Request handled by Security						
Call back when complete						
<b>Total Change Cost</b>						<b>\$ 3.89</b>
<b>Total Access Card Administration</b>						<b>\$ 31.64</b>

Note:

- 1) Cost, time and probability was provided by SMEs in Verizon's Security Group.
- 2) Loaded Labor Rates are for Clerk and Management positions.

**Highlighted information is redacted for reason #2. Parties may obtain this information by signing a non-disclosure agreement.**

Verizon: EIS Study - Florida  
 Non-recurring Rate Development  
 Cage Enclosure 25-100 SF

Ln	Cost Elements	Increment	Source	Cost (a)	Units (b)	Subtotal (c) = (a) * (b)
1	25 - 100 SF	1 SF fencing	Cage Encls 1-CS	\$ 8.34	289	\$ 2,410.26
2	Cage Gate	per gate	Cage Encls 1-CS	\$ 518.79	1	\$ 518.79
3	Cage Grounding Bar	per bar	Cage Ground Bar-CS	\$ 1,423.65	1	\$ 1,423.65
4	<b>Non-recurring Cost per Unit</b>		Sum(Ln 1..Ln 3)			<u>\$ 4,352.70</u>
5	<b>Rate Element</b>		Ln 4			<u><u>\$ 4,352.70</u></u>

Note:

The average square feet of fencing required for the cage sizes are based on typical caged arrangements previously provided to various ALECs across Verizon's service areas. Those average lengths by cage size are 289, 444, 599, 755 and 910 respectively.

Ln	Cost Elements	Increment	Source	Cost (a)	Units (b)	Subtotal (c) = (a) * (b)
1	101 - 200 SF	1 SF fencing	Cage Encls 1-CS	\$ 8.34	444	\$ 3,702.96
2	Cage Gate	per gate	Cage Encls 1-CS	\$ 518.79	1	\$ 518.79
3	Cage Grounding Bar	per bar	Cage Ground Bar-CS	\$ 1,423.65	1	\$ 1,423.65
4	<b>Non-recurring Cost per Unit</b>		Sum(Ln 1..Ln 3)			<u>\$ 5,645.40</u>
5	<b>Rate Element</b>		Ln 4			<u><u>\$ 5,645.40</u></u>

Note:

The average square feet of fencing required for the cage sizes are based on typical caged arrangements previously provided to various ALECs across Verizon's service areas. Those average lengths by cage size are 289, 444, 599, 755 and 910 respectively.



Verizon: EIS Study - Florida  
 Non-recurring Rate Development  
 Cage Enclosure 201-300 SF

Ln	Cost Elements	Increment	Source	Cost (a)	Units (b)	Subtotal (c) = (a) * (b)
1	201 - 300 SF	1 SF fencing	Cage Encls 1-CS	\$ 8.34	599	\$ 4,995.66
2	Cage Gate	per gate	Cage Encls 1-CS	\$ 518.79	1	\$ 518.79
3	Cage Grounding Bar	per bar	Cage Ground Bar-CS	\$ 1,423.65	1	\$ 1,423.65
4	<b>Non-recurring Cost per Unit</b>		Sum(Ln 1..Ln 3)			<u>\$ 6,938.10</u>
5	<b>Rate Element</b>		Ln 4			<u><u>\$ 6,938.10</u></u>

Note:  
 The average square feet of fencing required for the cage sizes are based on typical caged arrangements previously provided to various ALECs across Verizon's service areas. Those average lengths by cage size are 289, 444, 599, 755 and 910 respectively.

**Verizon: EIS Study - Florida**  
**Non-recurring Rate Development**  
**Cage Enclosure 301-400 SF**

Ln	Cost Elements	Increment	Source	Cost (a)	Units (b)	Subtotal (c) = (a) * (b)
1	301 - 400 SF	1 SF fencing	Cage Encls 1-CS	\$ 8.34	755	\$ 6,296.70
2	Cage Gate	per gate	Cage Encls 1-CS	\$ 518.79	1	\$ 518.79
3	Cage Grounding Bar	per bar	Cage Ground Bar-CS	\$ 1,423.65	1	\$ 1,423.65
4	<b>Non-recurring Cost per Unit</b>		Sum(Ln 1..Ln 3)			<u>\$ 8,239.14</u>
5	<b>Rate Element</b>		Ln 4			<u><u>\$ 8,239.14</u></u>

Note:  
 The average square feet of fencing required for the cage sizes are based on typical caged arrangements previously provided to various ALECs across Verizon's service areas. Those average lengths by cage size are 289, 444, 599, 755 and 910 respectively.

Verizon: EIS Study - Florida  
 Non-recurring Rate Development  
 Cage Enclosure 401-500 SF

Ln	Cost Elements	Increment	Source	Cost (a)	Units (b)	Subtotal (c) = (a) * ( b)
1	401 - 500 SF	1 SF fencing	Cage Encls 1-CS	\$ 8.34	910	\$ 7,589.40
2	Cage Gate	per gate	Cage Encls 1-CS	\$ 518.79	1	\$ 518.79
3	Cage Grounding Bar	per bar	Cage Ground Bar-CS	\$ 1,423.65	1	\$ 1,423.65
4	Non-recurring Cost per Unit		Sum(Ln 1..Ln 3)			<u>\$ 9,531.84</u>
5	Rate Element		Ln 4			<u><u>\$ 9,531.84</u></u>

Note:  
 The average square feet of fencing required for the cage sizes are based on typical caged arrangements previously provided to various ALECs across Verizon's service areas. Those average lengths by cage size are 289, 444, 599, 755 and 910 respectively.

Verizon: EIS Study - Florida  
 Non-recurring Rate Development  
 Cage Enclosure Augment

Ln	Cost Elements	Increment	Source	Cost (a)
	<b>Cage Enclosure Augment</b>			
1	Cage Fencing	per square foot	Cage Encls 1-CS	\$ 11.81
2	<b>Non-recurring Cost per Unit</b>		Ln 1	<u>\$ 11.81</u>
3	<b>Rate Element</b>		Ln 2	<u><u>\$ 11.81</u></u>

Summary of Cage Fencing Costs:	
Over 100 Square Feet Floor Space (per Square Foot)	\$ 8.34
75 - 99 Square Feet Floor Space (per Square Foot)	\$ 8.88
50 - 74 Square Feet Floor Space (per Square Foot)	\$ 9.78
25 - 49 Square Feet Floor Space (per Square Foot)	\$ 11.81
Cage Gate	\$ 518.79

Description	Cage Fencing Sq. Ft Surface (Note 1)	Cage Cost	Gate Cost
California Costs -- Adjusted (Note 2)			
Texas Costs -- Adjusted (Note 3)			
National Average Cost			
Adjustment to Make National Average Specific to Florida (-8%)			
Florida Cost	338.30	\$ 2,821.57	\$ 518.79

Note:

Highlighted information is redacted for reasons #3 and #4. Parties may obtain this information by signing a non-disclosure agreement.

Ln	Description	Source	Cage Fencing Space Area			
			Over 100 Square Feet A	75 - 99 Square Feet B	50 - 74 Square Feet C	25 - 49 Square Feet D
1	Cage Fencing Floor Space Area (Square Feet)					
2	Square Root of Cage Floor Space	SQRT Ln 1				
3	Percent of Cage Floor Space	Ln 2 / Ln2A				
4	Average Cage Fencing Area (Square Feet)	Ln 3 * Ln 4A				
5	Cage Cost per Square Foot	Note 1				
6	Average Cage Fencing Area Cost	Ln 4A * Ln 5A				
7	Average Cage Enclosure Cost	Cage Enclosure - 1				
8	Vendor Engineering & Overhead Cost	Ln 7 - Ln 6				
9	Vendor Engineering & Overhead Cost per Square Foot	Ln 8A / Ln 4				
10	Total Cage Enclosure Cost per Square Foot of Fence Surface	Ln 5A + Ln 9	\$ 8.34	\$ 8.88	\$ 9.78	\$ 11.81

Note:

**Highlighted information is redacted for reasons #1 and #3. Parties may obtain this information by signing a non-disclosure agreement.**

Verizon: EIS Study - Florida  
 Non-recurring Rate Development  
 Cage Grounding Bar

Ln	Cost Elements	Increment	Source	Cost
1	Cage Grounding Bar	per bar	Cage Ground Bar-CS	\$ 1,423.65
2	Non-recurring Cost per Unit		Ln 1	<u>\$ 1,423.65</u>
3	Rate Element		Ln 2	<u><u>\$ 1,423.65</u></u>

Verizon: EIS Study - Florida  
 Non-recurring Cost Development  
 Cage Grounding Bar

Collocation Grounding System

Qty	Cost/LF	Footage	Hours	LLR	Total	
						<b>Cage Grounding Bar</b>
						<b>Material</b>
						20" Ground Bar /w Wall Mounting Assy.
						350 MCM Ground Cable
						Connector Lug
						<b>Total Material</b>
						<b>Material Factor</b>
						<b>Material Loadings</b>
						<b>Equipment Investment</b>
						<b>Labor</b>
						Equipment Engineer
						Equipment Installer
						Travel
						Mount Ground Bar
						Run 350 MCM Cable
						Tap Ground Cable (per end)
						<b>Total Labor and Installation</b>
						<b>Total Engineering and Installation Labor</b>
						<b>Total Collocation Grounding System</b>
					<b>\$ 1,423.65</b>	

Source: GTE Advanced Materials System.

Highlighted information is redacted for reasons #1, #2 and #3.  
 Parties may obtain this information by signing a non-disclosure  
 agreement.



Verizon: EIS Study - Florida  
 Non-recurring Rate Development  
 Overhead Superstructure

Ln	Cost Elements	Increment	Source	Cost (a)	Units (b)	Subtotal (c) = (a) * (b)
<b>Overhead Superstructure</b>						
1	Cable Racking (Dedicated) - Materials	per linear foot	Overhead Superstructure 1-CS	\$ 21.84	39	\$ 851.91
2	Cable Racking (Dedicated) - Installation	per linear foot	Overhead Superstructure 1-CS	\$ 10.14	39	\$ 395.63
3	<b>Non-recurring Cost per Element</b>		Sum(Ln 1.. Ln 3)			\$ 1,247.53
4	<b>Rate Element</b>		Ln 4			\$ 1,247.53

Verizon: EIS Study - Florida  
 Non-recurring Cost Development  
 Overhead Superstructure

Ln	Description	Source	Calculation
Overhead Superstructure - Materials			
1	Overhead Superstructure and Hardware - per ft. Increments	Overhead Superstructure 2-CS	
Overhead Superstructure - Installation			
2	Installation Factor	EF&I-CS	
3	Installation Amount	Ln 1 * Ln 2	_____
4	Total Investment - per ft. Increments	Ln 1 + Ln 3	

**Highlighted information is redacted for reason #3. Parties may obtain this information by signing a non-disclosure agreement.**

Verizon: EIS Study - Florida  
 Non-recurring Cost Development  
 Overhead Superstructure

	<u>Cost</u>	<u>Quantity</u>	<u>Extended Amount</u>
24" Cable Rack			
Cable Rack Junction			
Power & Signal Bracket			
Cable Rack Support			
10' Thread Rod			
10' Aux Frame Bar			
Ceiling Support			
Material Cost			
Material Loading Factor			
Material Loading Cost			
Total Cost for 10' Rack			
<b>Overhead Superstructure and Hardware - per ft. Increments</b>			

1) Source: GTE Advanced Materials System.

**Highlighted information is redacted for reasons #1 and #3. Parties may obtain this information by signing a non-disclosure agreement.**

Verizon: EIS Study - Florida  
 Non-recurring Rate Development  
 Facility Pull - Engineering (Metallic & Fiber Optic Patchcord)

Ln	Cost Elements	Increment	Source	Cost
1	Facility Cable/Fiber Optic Patchcord - Pull - Engineering	per project	Facility Pull & Term-CS	\$ 37.63
2	Travel Time	per project	Facility Pull & Term-CS	\$ 45.98
3	<b>Non-recurring Cost per Element</b>		Sum(Ln 1.. Ln 2)	\$ 83.61
4	<b>Rate Element</b>		Ln 3	\$ 83.61

Verizon: EIS Study - Florida  
 Non-recurring Rate Development  
 Facility Pull - Labor/Fiber Optic Patchcord Pull - Labor/Microwave Facility Pull - Labor

Ln	Cost Elements	Increment	Source	Cost	Units	Subtotal
				(a)	(b)	(c) = (a) *( b)
1	Facility Cable - Pull	per cable run	Facility Pull & Term-CS	\$ 1.15	112	\$ 128.80
2	Fiber Optic Patchcord - Pull	per cable run	Facility Pull & Term-CS	\$ 1.15	185	\$ 212.75
3	Microwave - Pull	per linear ft	Facility Pull & Term-CS	\$ 1.15	1	\$ 1.15

Note:

- 1) The 112 units represent the average DS0, DS1, and DS3 cable lengths for 59 central offices in Florida.
- 2) The length for Fiber Optic Patchcord was derived from the average number of feet ordered through all central offices for a two year period.

Verizon: EIS Study - Florida  
 Non-recurring Rate Development  
 Facility Cable/Fiber Optic Patchcord - Termination

Ln	Cost Elements	Increment	Source	Cost (a)	Units (b)	Total (c) = (a) *( b)
1	DS0 Cable Termination	per 100 pair	Facility Pull & Term-CS	\$ 4.60	1	\$ 4.60
2	Category 5 Cable Termination	per 25 pair	Facility Pull & Term-CS	\$ 1.15	1	\$ 1.15
3	DS1 Cable Termination	per 28 pair	Facility Pull & Term-CS	\$ 1.15	1	\$ 1.15
4	DS3 Coaxial Cable Termination (Preconnectorized)	per coaxial cable	Facility Pull & Term-CS	\$ 1.15	1	\$ 1.15
5	DS3 Coaxial Cable Termination (Unconnectorized)	per coaxial cable	Facility Pull & Term-CS	\$ 11.49	1	\$ 11.49
6	Fiber Optic Patchcord Termination	per termination	Facility Pull & Term-CS	\$ 1.15	1	\$ 1.15

**Verizon: EIS Study - Florida**  
**Non-recurring Cost Development**  
**Facility Cable/Fiber Optic Patchcord/Microwave - Pull and Termination**

Ln	Description	Source	Calculation
<u>Transmission Line DS0 / Voicegrade Level</u>			
1	100 pair DS0 - Facility Pull (per foot) Cost	Cable Run Labor-CS	
2	Termination (100 pair DS0s) Cost (C)	Cable Run Labor-CS	
3	Termination (100 pair DS0s) Cost (UC)	Cable Run Labor-CS	
<u>Transmission Line DS1</u>			
4	28 pair DS1 - Facility Pull (per foot) Cost	Cable Run Labor-CS	
5	Termination Cost (C)	Cable Run Labor-CS	
6	Termination Cost per 28 pair (UC)	Cable Run Labor-CS	
<u>Transmission Line DS3/Microwave</u>			
7	Coax DS3 - Facility Pull (per foot)	Cable Run Labor-CS	
8	Termination Cost (C)	Cable Run Labor-CS	
9	Termination Cost (UC)	Cable Run Labor-CS	
<u>Orange Shielded Cable</u>			
10	Facility Pull (per foot)	Cable Run Labor-CS	
11	Termination (25pr)	Cable Run Labor-CS	
12	Material Cost (per Foot)	Cable-CS	
<u>Category 5 Cable</u>			
13	Facility Pull (per foot)	Cable Run Labor-CS	
14	Termination (25 pr)	Cable Run Labor-CS	

**Highlighted information is redacted for reasons #1 and #2. Parties may obtain this information by signing a non-disclosure agreement.**

Verizon: EIS Study - Florida  
 Non-recurring Cost Development  
 Facility Cable/Fiber Optic Patchcord/Microwave - Pull and Termination

Ln	Description	Source	Calculation
<u>Transmission Line Fiber</u>			
15	Fiber - Facility Pull (per foot)	Cable Run Labor-CS	
16	Termination Cost per Fiber (48 fiber cable or less)	Cable Run Labor-CS	
17	Termination Cost per Fiber (greater than 48 fiber cable)	Cable Run Labor-CS	
<u>Fiber Optic Patchcord</u>			
18	Fiber Optic Patchcord - Pull (per foot)	Cable Run Labor-CS	
19	Termination Cost per Fiber ( C )	Cable Run Labor-CS	
<u>DS0/DS1/DS3/Shielded/Category 5/Fiber/BITS Timing Facility Pull Engineering</u>			
20	Engineering for Facility Pull (per Collocation Request per CO)	Cable Run Labor-CS	
21	Travel Time for Installer (per Collocation Request per CO)	Cable Run Labor-CS	

Note:  
 "C" designates the cable with a connector, "UC" designates a cable without a connector.

**Highlighted information is redacted for reasons #1 and #2. Parties may obtain this information by signing a non-disclosure agreement.**



**Verizon: EIS Study - Florida**  
**Non-recurring Cost Development**  
**Facility Cable/Power Cable/Fiber Optic Patchcord/Microwave - Pull and Termination**

Facility Pull - Transmission - Power/Ground Line Run and Installation Details

Ln	Description	Number of Feet	Hours per Foot	Total	Loaded	Cost
		(Ln 1-2)	(Ln 1-2)			
		Number of Terms	Hours per Terms	Hours	Labor Rate	
		(Ln 3-6, 9-11)	(Ln 3-6, 9-11)	C = A * B	D = Note 1	E = C * D
		A	B = Note 2			
1	Telecommunications Facility Pull Cost					
2	Power/Ground Cable Pull Cost (Note 5, 7)					
	Termination:					
3	DS-0 (100 pair DS0s) (C) (Note 4)					
4	DS1 (28 pair DS1s) (C) (Note 4)					
5	DS3 (1 DS3) (C) (Note 4)					
6	DS-3 (UC) (Note 4)					
7	Per Fiber (48 fiber cable or less) (Note 6)					
8	Per Fiber (greater than 48 fiber cable) (Note 6)					
9	Power Cable (2 terminations per cable)					
10	Shielded Cable					
11	Category 5 (25 pair) (C)					
12	Fiber Optic Patchcord (C) (Note 4)					
13	Engineering Facility Cable/Fiber Optic Patchcord (Note 3) - Equipment Engineer					
14	Engineering Power (Note 3)					
15	Travel Time - Equipment Installer					
16	DS0 Termination to OSP Connector at MDF (Vertical side) (UC) (Note 8)					
17	DS1 Termination to OSP Connector at MDF (Vertical side) (UC) (Note 8)					

Note:

Highlighted information is redacted for reasons #1, #2, #3 and #4. Parties may obtain this information by signing a non-disclosure agreement.

Verizon: EIS Study - Florida  
 Non-recurring Rate Development  
 Fiber Cable Pull

Ln	Cost Elements	Increment	Source	Cost
1	Fiber Cable Pull-Engineering	per project	Fiber Cable Pull-CS	\$ 1,371.12
2	Fiber Cable Pull-Place Innerduct	per innerduct foot	Fiber Cable Pull-CS	\$ 0.73
3	Fiber Cable Pull-Labor	per linear foot	Fiber Cable Pull-CS	\$ 0.49
4	Fiber Cable Pull-Cable Fire Retardant	per occurrence	Fiber Cable Pull-CS	\$ 45.98

Verizon: EIS Study - Florida  
 Non-recurring Cost Development  
 Fiber Cable Pull

Fiber Cable Pull	
Description	Fiber Cable Placement per Foot (labor) A = Note 1
Fiber Cable Pull	\$ 0.49

Innerduct				
Description	Innerduct Material per Foot B = Note 3	EF&I Factor C = EF&I-CS	Innerduct Placement per Foot (Installation Cost) D = B * C	Innerduct - Total installed Cost per Foot E = B + D
Innerduct Placement				\$ 0.73

Engineering for Cable Pull			
Description	Hours J = Note 4	Loaded Labor Rate K = LLR-CS	Engineering for Cable Pull Cost L = J * K
OSP Engineer - per Collocation Request per CO			\$ 1,371.12

Cable Fire Retardant Costs			
Description	Total Hours M = Note 5	Loaded Labor Rate N = LLR-CS	Cable Fire Retardant Cost O = M * N
Cable Fire Retardant Cost			\$ 45.98

Note:

Highlighted information is redacted for reasons #1, #2, #3 and #4. Parties may obtain this information by signing a non-disclosure agreement.

Verizon: EIS Study - Florida  
 Non-recurring Rate Development  
 Fiber Cable Splice

Ln	Cost Elements	Increment	Source	Cost
1	Fiber Cable Splice - Engineering	per splicing project	Cable Splice-CS	\$ 68.56
2	Fiber Cable Splice	per fiber strand	Cable Splice-CS	\$ 41.03

**Verizon: EIS Study - Florida**  
**Non-recurring Cost Development**  
**Cable Splice**

Ln	Description	Source	Cost per Pair/Fiber	Loaded Labor Rate	Hours	Total Cost
<b>Metallic Cable</b>						
<b>Labor</b>						
1	Engineering Cable Splice (per Collocation Request per CO)	Note 2				\$ 68.56
2	Splice cost per pair(greater than 200 pair)	Note 1				\$ 0.65
3	Splice cost per pair(200 pair or less)	Note 1				\$ 1.20
<b>Fiber Cable</b>						
<b>Labor</b>						
4	OSP Engineer (per Collocation Request per CO)	Note 2				\$ 68.56
5	Splice cost per fiber strand (48 fiber strand cable or less)	Note 1				\$ 41.03
6	Splice cost per fiber strand (greater than 48 fiber strand cable)	Note 1				\$ 38.64

Note:

**Highlighted information is redacted for reasons #1, #2 and #3. Parties may obtain this information by signing a non-disclosure agreement.**

Verizon: EIS Study - Florida  
 Non-recurring Rate Development  
 DC Power Cable

Ln	Cost Elements	Increment	Source	Cost (a)	Frequency (b)	Units (c)	Rate Element (d) = (a)*(b)*(c)
<b>DC Power Cable</b>							
1	DC Power Cable - Termination	per power run	Cable Run Labor-CS	\$ 68.96	1.00	1	\$ 68.96
2	DC Power Cable - Pull	per linear foot	Cable Run Labor-CS	\$ 11.49	1.00	67	\$ 769.83
3	Total DC Power Cable Pull/Termination	per cable					<u>\$ 838.79</u>
4	DC Power Cable - Engineering/Travel	per project	Cable Run Labor-CS	\$ 83.61	1.00	1	<u>\$ 83.61</u>
5	Wire Ground #6	per linear foot	Cable-CS	\$ 0.14	1.00	67	<u>\$ 9.38</u>

Note:

The average length from the power source (BDFB) to the collocation arrangement is 67 feet. The units (67) for DC Power-Cable Pull is the average linear feet of power cable pulled for 1 cable run. The Ground Wire units (67) is the average linear feet of Ground Wire for each collocation arrangement.

Verizon: EIS Study - Florida  
Non-recurring Rate Development  
Cable

Ln	Cost Elements	Increment	Source	Cost (a)	Units (b)	Total (c) = (a) * (b)
<b>Facility Cable</b>						
1	DS0 Cable (Connectorized/100 feet) 100 pair	per cable run	Cable-CS	\$ 155.22	171	\$ 265.43
2	DS1 Cable (Connectorized/100 feet)	per cable run	Cable-CS	\$ 154.05	79	\$ 121.70
3	DS3 Coax Cable	per cable run	Cable-CS	\$ 0.42	86	\$ 36.12
4	Category 5 Connectorized 100ft	per linear foot	Cable-CS	\$ 1.17		
5	Category 5 Connectorized 150ft	per linear foot	Cable-CS	\$ 1.13		
6	Category 5 Connectorized 200ft	per linear foot	Cable-CS	\$ 1.12		
7	Average Cost per linear foot	per linear foot		\$ 1.14	1	\$ 1.14
<b>Power Cable</b>						
8	Wire Power 1/0	per cable run	Cable-CS	\$ 0.49	67	\$ 32.83
9	Wire Power 2/0	per cable run	Cable-CS	\$ 0.60	67	\$ 40.20
10	Wire Power 3/0	per cable run	Cable-CS	\$ 0.74	67	\$ 49.58
11	Wire Power 4/0	per cable run	Cable-CS	\$ 0.94	67	\$ 62.98
12	Wire Power 350 MCM	per cable run	Cable-CS	\$ 1.67	67	\$ 111.89
13	Wire Power 500 MCM	per cable run	Cable-CS	\$ 3.27	67	\$ 219.09
14	Wire Power 750 MCM	per cable run	Cable-CS	\$ 5.04	67	\$ 337.68
<b>Fiber Optic Patch Cord</b>						
15	Fiber Optic Patch Cord -24 Fiber (Connectorized)	per cable run	Cable-CS	\$ 4.19	185	\$ 775.15

Note:

- 1) The units for DSO, DS1, DS3 and Shielded cables are based on the average linear feet of cable for 59 central offices in Florida.
- 2) The cost for Category 5 Connectorized cable is the average cost for 100', 150' and 200' cable lengths then divided by the average length of 150'  $((\$116.52 + \$169.8 + \$223.09) / 3 / 150 \text{ ft.})$ .
- 3) The units for power cables are based on the average linear feet of cable for 59 central offices in Florida. The average length from the BDFB to the collocation arrangement is 67 feet.
- 4) The length for Fiber Optic Patch Cord was derived from the average number of feet ordered in all Verizon central offices over a two year period.

Description	Cost A	Mat'l Loadings Factor B	Mat'l Loadings Cost C=A*B	Extended Cost D=C+A
<b>Facility Cable</b>				
DS0 Cable (Connectorized/100 feet) 100 pair				
DS1 Cable (Connectorized/100 feet)				
DS3 Coax Cable (per foot)				
Orange Shielded Cable (per foot)				
Category 5 Connectorized (per100 feet)				
Category 5 Connectorized (per150 feet)				
Category 5 Connectorized (per200 feet)				
<b>Power Cable</b>				
Wire Power 1/0 (per foot)				
Wire Power 2/0 (per foot)				
Wire Power 3/0 (per foot)				
Wire Power 4/0 (per foot)				
Wire Power 350 MCM (per foot)				
Wire Power 500 MCM (per foot)				
Wire Power 750 MCM (per foot)				
<b>Ground Cable</b>				
Wire Ground #6 (per foot)				
<b>Fiber Optic Patch Cord</b>				
Fiber Optic Patch Cord-24 fiber (connectorized) (per foot)				

Note:

Highlighted information is redacted for reasons #1 and #3. Parties may obtain this information by signing a non-disclosure agreement.



Verizon: EIS Study - Florida  
 Non-recurring Rate Development  
 Virtual Equipment Installation

Ln	Cost Elements	Increment	Source	Cost
1	Virtual Equipment Installation	per quarter rack	Virtual Equip Blended-CS	\$ 3,693.59
2	Non-recurring Cost per Unit		Ln 1	\$ 3,693.59
3	Rate Element		Ln 2	\$ 3,693.59

Verizon: EIS Study - Florida  
 Non-recurring Cost Development  
 Virtual Equipment Installation

Engineering and Installation (E&I)

Ln	Description	Source	Total E&I Cost per Base Unit A	Average # of Base Units per Rack B = Note 1	E&I Cost per Rack C=A*B	Frequency of Equipment D	Weighted E&I Cost per Rack of Equipment E=C*D
<b>Circuit Equipment:</b>							
1	ATM	Virtual Equip-CS					
2	DSLAM	Virtual Equip-CS					
3	Frame Relay	Virtual Equip-CS					
4	Routers	Virtual Equip-CS					
5	OC3	Virtual Equip-CS					
6	OC12	Virtual Equip-CS					
7	OC24	Virtual Equip-CS					
8	OC48	Virtual Equip-CS					
9	NGDLC	Virtual Equip-CS					
10	Cost per Rack	Sum(Ln 1..Ln 9)					
11	Engineering & Installation per Quarter Rack	Ln 10 / 4					\$ 3,693.59

Note:

**Highlighted information is redacted for reasons #1, #3 and #4. Parties may obtain this information by signing a non-disclosure agreement.**

Verizon: EIS Study - Florida  
 Non-recurring Cost Development  
 Virtual Equipment Installation

Equipment and Installation per Base Unit (E&I)

Description	Source	CO Equipment	CO Equipment	CO Equipment	CO Equipment	Total E&I Cost E=(A*B)+(C*D)
		Engineering Hours A	Engineering Loaded Labor Rate B	Installation Tech Hours C	Installation Tech Loaded Labor Rate D	

Equipment (per Base Unit):

ATM	Note 1, 2
DSLAM	Note 1, 2
Frame Relay	Note 1, 2
Routers	Note 1, 2
OC3	Note 3
OC12	Note 3
OC24	Note 3
OC48	Note 3
NGDLC	Note 3

Note:

**Highlighted information is redacted for reasons #2 and #3. Parties may obtain this information by signing a non-disclosure agreement.**

Verizon: EIS Study - Florida  
 Non-recurring Rate Development  
 Virtual Software Upgrades

Ln	Cost Elements	Increment	Source	Cost
1	Software Upgrades	per base unit	Virtual Software Blended-CS	\$ 98.62
2	Non-recurring Cost per Unit		Ln 1	\$ 98.62
3	Rate Element		Ln 2	\$ 98.62

Verizon: EIS Study - Florida  
 Non-recurring Cost Development  
 Virtual Software Upgrades

Ln	Description	Source	Software Upgrades		
			Total Cost	Frequency of Software Upgrade	Weighted Cost per Software Upgrade
			A	B	C = A * B
Equipment (per Upgrade per Base Unit)					
1	ATM	Virtual Software-CS			
2	DSLAM	Virtual Software-CS			
3	Frame Relay	Virtual Software-CS			
4	Routers	Virtual Software-CS			
5	SMDS	Virtual Software-CS			
6	Cost per Software Upgrade	Sum(Ln 1..Ln 5)		1.000 \$	98.62

**Highlighted information is redacted for reasons #1 and #3. Parties may obtain this information by signing a non-disclosure agreement.**

Verizon: EIS Study - Florida  
 Non-recurring Cost Development  
 Virtual Software Upgrades

Ln	Description	Source	Software Upgrades		
			Loaded Labor Rate	Labor Hours per	
				Software Upgrade	Labor Cost per Upgrade
A	B	C=A*B			
Equipment (per Upgrade per Base Unit)					
1	ATM	Note 1, 3			
2	DSLAM	Note 2, 3			
3	Frame Relay	Note 1, 3			
4	Routers	Note 2, 3			
5	SMDS	Note 2, 3			

Note:

**Highlighted information is redacted for reasons #2 and #3. Parties may obtain this information by signing a non-disclosure agreement.**

Verizon: EIS Study - Florida  
 Non-recurring Rate Development  
 Virtual Card Installation

Ln	Cost Elements	Increment	Source	Cost
1	Card Installation	per card	Virtual Card Install Blended-CS	\$ 238.54
2	Non-recurring Cost per Unit		Ln 1	\$ 238.54
3	Rate Element		Ln 2	\$ 238.54

Verizon: EIS Study - Florida  
 Non-recurring Cost Development  
 Virtual Card Installation

				Virtual Card Installation		
Ln	Description	Source	Total Cost	Frequency of Card Install	Weighted Cost per Card Installed	
			A	B	C=A*B	
Module (per Module)						
1	ATM	Virtual Card Install-CS				
2	DSLAM	Virtual Card Install-CS				
3	Frame Relay	Virtual Card Install-CS				
4	Routers	Virtual Card Install-CS				
5	SMDS	Virtual Card Install-CS				
6	DS1	Virtual Card Install-CS				
7	DS3	Virtual Card Install-CS				
8	NGDLC	Virtual Card Install-CS				
9	Cost per Card Installed	Sum (Ln 1..Ln 8)		1.000	\$ 238.54	

Highlighted information is redacted for reasons #1 and #3. Parties may obtain this information by signing a non-disclosure agreement.



Verizon: EIS Study - Florida  
 Non-recurring Cost Development  
 Virtual Card Installation

Module Installation (per Module)

Description	Source	CO Equipment		CO Equipment		Total Virtual Card Install Cost
		Engineering Hours	Loaded Labor Rate	Installation Tech Hours	Installation Tech Loaded Labor Rate	
		A	B	C	D	$E=(A*B)+(C*D)$
Module (per Module)						
ATM	Note 1, 2					
DSLAM	Note 1, 2					
Frame Relay	Note 1, 2					
Routers	Note 1, 2					
SMDS	Note 1, 2					
DS1	Note 1					
DS3	Note 1					
NGDLC	Note 1					

Note:

Highlighted information is redacted for reasons #2 and #3. Parties may obtain this information by signing a non-disclosure agreement.

Verizon: EIS Study - Florida  
 Non-recurring Rate Development  
 Engineering/Major Augment - Virtual

Ln	Cost Elements	Increment	Source	Cost
1	Engineering/Major Augment - Virtual	per occurrence	Engineering - Virtual-CS	\$ 756.67
2	Non-recurring Cost Per Unit		Ln 1	\$ 756.67
3	Rate Element		Ln 2	\$ 756.67

Verizon: EIS Study - Florida  
 Non-recurring Cost Development  
 Engineering/Major Augment - Virtual

Description	Loaded Labor		Cost
	Rate A = LLR-1	Hours B	
<hr/>			
Pre-Acceptance (Initial Site Audit)			
Building Engineer			
CO Equipment Engineer			<hr/>
Post-Acceptance			
CO Equipment Engineer (Note 1)			
Outside Plant Engineer (Note 1)			<hr/>
Total			\$ 756.67

Note:

**Highlighted information is redacted for reasons #2 and #3. Parties may obtain this information by signing a non-disclosure agreement.**

**Verizon: EIS Study - Florida**  
**Non-recurring Rate Development**  
**BITS Timing**

Ln	Cost Elements	Increment	Source	Cost (a)	Frequency (b)	Units (c)	Subtotal (d) = (a)*(b)*(c)
<b>Bits Timing</b>							
1	Engineering	per project	Facility Pull & Term-CS	\$ 37.63	1.00	1	\$ 37.63
2	Pull Shielded Cable	1 lin ft	Facility Pull & Term-CS	\$ 1.15	1.00	131	\$ 150.65
3	Material Cost - Orange Shielded Cable	1 lin ft	Cable-CS	\$ 0.15	1.00	131	\$ 19.65
4	Terminate Shielded Cable	per termination	Facility Pull & Term-CS	\$ 1.15	1.50	1	\$ 1.73
5	<b>Non-recurring Cost per Unit</b>		Sum(Ln 1.. Ln 4)				\$ 209.66
6	<b>Rate Element</b>		Ln 5				\$ 209.66

Note:  
 The units (131) for Material and Labor is the average length, in feet, from the Main Distribution Frame (MDF) to the Collocation arrangement for 59 central offices in Florida. This information was retrieved from Collocation Engineering Specification worksheets for these arrangements. Since no data was available to calculate an average length of the BITS Clock to the Collocation arrangement, the average MDF to Collocation length is being used as a surrogate. The frequency of 1.5 for the Terminate Shielded Cable cost element is derived from the assumption that there is a 50% probability of having one termination and a 50% probability of having two terminations.

**Verizon: EIS Study - Florida  
 Non-recurring Rate Development  
 Engineering - Adjacent On-Site**

<b>Ln</b>	<b>Cost Elements</b>	<b>Increment</b>	<b>Source</b>	<b>Cost</b>
1	Engineering - Adjacent On-Site	per occurrence	Engineering - On Site-CS	<u>\$ 1,292.21</u>
2	<b>Non-recurring Cost Per Unit</b>		Ln 1	<u>\$ 1,292.21</u>
3	<b>Rate Element</b>		Ln 2	<u><u>\$ 1,292.21</u></u>

**Verizon: EIS Study - Florida  
 Non-recurring Cost Development  
 Engineering - Adjacent On-Site**

Description	Loaded Labor Rate	Adjacent On-Site	
	A = LLR-1	On-Site Hours	On-Site Costs
		B	C = A * B
<b>Building Engineer</b>			
Review CO plans for critical on-site locations			
Contact local municipality for codes			
Contact/visit utility companies			
Travel to Site			
Inspect CO premise for hut location			
Obtain soil sample			
Inspect power entrance/transfer switch			
Work up order			
<b>CO Equipment Engineer</b>			
Travel to Site			
Inspect power entrance/transfer switch			
Inspect CO premise for hut location			
Work up order			
<b>OSP Engineer</b>			
Travel to Site			
Inspect vault/manhole conduit system			
Inspect CO premise for hut location			
Work up order			
<b>Total</b>			<b>\$ 1,292.21</b>

**Highlighted information is redacted for reasons #2, #3 and #4. Parties may obtain this information by signing a non-disclosure agreement.**

Verizon: EIS Study - Florida  
 Non-recurring Rate Development  
 Adjacent On-Site Metallic Facility Pull

Ln	Cost Elements	Increment	Source	Cost
1	Adjacent Metallic Facility Pull - Engineering	per project	Facility Pull & Term-CS	\$ 37.63
2	Adjacent Metallic Facility Pull - Travel	per project	Facility Pull & Term-CS	\$ 45.98
3	Total		Ln 1 + Ln 2	<u>\$ 83.61</u>
4	Adjacent Metallic Facility Pull - Labor	per linear foot	Facility Pull & Term-CS	<u>\$ 1.15</u>

Verizon: EIS Study - Florida  
 Non-recurring Rate Development  
 Adjacent On-Site - Facility Cable Termination

Ln	Cost Elements	Increment	Source	Cost
1	Adjacent-DSO Cable Termination (Connectorized)	per 100 pair	Facility Pull & Term-CS	\$ 4.60
2	Adjacent-DSO Cable Termination (Unconnectorized)	per 100 pair	Facility Pull & Term-CS	\$ 45.98
3	Adjacent-Category 5 Cable Termination (Connectorized)	per 25 pair	Facility Pull & Term-CS	\$ 1.15
4	Adjacent-DS1 Cable Termination (Connectorized)	per 28 pair	Facility Pull & Term-CS	\$ 1.15
5	Adjacent-DS1 Cable Termination (Unconnectorized)	per 28 pair	Facility Pull & Term-CS	\$ 34.48
6	Adjacent-DS3 Coaxial Cable Termination (Connectorized)	per coaxial cable	Facility Pull & Term-CS	\$ 1.15
7	Adjacent-DS3 Coaxial Cable Termination (Unconnectorized)	per coaxial cable	Facility Pull & Term-CS	\$ 11.49
8	Adjacent-Fiber Cable Termination	per fiber termination	Facility Pull & Term-CS	\$ 41.03



Verizon: EIS Study - Florida  
 Non-recurring Rate Development  
 Adjacent On-Site Fiber Cable Pull

Ln	Cost Elements	Increment	Source	Cost
1	Adjacent Fiber Cable Pull Engineering	per project	Fiber Cable Pull-CS	\$ 1,371.12
2	Adjacent Fiber Cable Pull-Place Innerduct	per innerduct foot	Fiber Cable Pull-CS	\$ 0.73
3	Adjacent Fiber Cable Pull - Labor	per linear foot	Fiber Cable Pull-CS	\$ 0.49
4	Adjacent Cable Fire Retardant	per occurrence	Fiber Cable Pull-CS	\$ 45.98

**Verizon: EIS Study - Florida**  
**Non-recurring Rate Development**  
**Adjacent On-Site Metallic Cable Pull**

Ln	Cost Elements	Increment	Source	Cost
1	Adjacent Metallic Cable Pull - Engineering	per project	Metallic Cable Pull-CS	\$ 1,371.12
2	Adjacent Metallic Cable Pull - Labor	per linear foot	Metallic Cable Pull-CS	\$ 0.60

Verizon: EIS Study - Florida  
 Non-recurring Cost Development  
 Metallic Cable Pull Cost

Metallic Cable Pull
---------------------

Description	Metallic Cable Placement per Foot (labor) A = Note 1
Metallic Cable Pull < 1.5" Dia.	
Metallic Cable Pull > 1.5" Dia.	

Engineering for Cable Pull
----------------------------

Description	Hours D = Note 2	Loaded Labor Rate E = LLR-CS	Engineering for Cable Pull Cost F = D * E
OSP Engineer - per Collocation Request per CO			\$ 1,371.12

Cable Fire Retardant Costs
----------------------------

	Total Hours G = Note 3	Loaded Labor Rate H = LLR-CS	Cable Fire Retardant Cost I = G * H
Cable Fire Retardant Cost			\$ 45.98

Note:

Highlighted information is redacted for reasons #1, #2 and #3. Parties may obtain this information by signing a non-disclosure agreement.

Verizon: EIS Study - Florida  
 Non-recurring Rate Development  
 Adjacent On-Site Metallic Cable Splice

Ln	Cost Elements	Increment	Source	Cost
1	Adjacent Metallic Cable Splice - Engineering	per splicing project	Cable Splice-CS	\$ 68.56
2	Adjacent Metallic Cable Splicing (greater than 200 pair)	per pair	Cable Splice-CS	\$ 0.65
3	Adjacent Metallic Cable Splicing (less than 200 pair)	per pair	Cable Splice-CS	\$ 1.20

Verizon: EIS Study - Florida  
 Non-recurring Rate Development  
 Adjacent On-Site Fiber Cable Splice

Ln	Cost Elements	Increment	Source	Cost
1	Adjacent Fiber Cable Splice - Engineering	per splicing project	Cable Splice-CS	\$ 68.56
2	Adjacent Fiber Cable Splicing (48 fiber strand cable or less)	per fiber strand	Cable Splice-CS	\$ 41.03
3	Adjacent Fiber Cable Splicing (greater than 48 fiber strand)	per fiber strand	Cable Splice-CS	\$ 38.64

Verizon: EIS Study - Florida  
 Non-recurring Rate Development  
 Collocation Premise Space Report - Optional

Ln	Cost Elements	Increment	Source	Cost (a)	Frequency (b)	Fill Factor (c)	Total (d) = (a)*(b)/(c)
1	Comprehensive Evaluation	per CO request	Premise Space Report-CS	\$ 6,020.26	50.00%	4	\$ 752.53
2	Annual Evaluation	per CO request	Premise Space Report-CS	\$ 4,816.21	50.00%	4	\$ 602.03
3	<b>Non-recurring Cost Per Unit</b>		Sum(Ln 1.. Ln 2)				\$ 1,354.56
4	<b>Rate Element</b>		Ln 3				\$ 1,354.56

Note:

The \$6,020.26 represents the cost associated with a Comprehensive Evaluation in Year #1. The \$4,816.21 represents the cost associated with an Annual Evaluation in Year #2 and beyond. Each of these two costs are weighted 50% in the algorithm to represent both costs. These costs are then divided by 4 to represent the forecasted ALEC demand for the Space Report on a per CO basis.

Verizon: EIS Study - Florida  
Non-recurring Cost Development  
Collocation Premise Space Report - Optional

Report Description	Network Designer & Building Services	Local Network Designer	Total Hours	Loaded Labor Rate	Total Cost
Comprehensive Evaluation					\$ 6,020.26
Limited Evaluation					\$ 2,408.10
Annual Evaluation					\$ 4,816.21

Note:

See job description of activities in the narrative.

**Highlighted information is redacted for reasons #2 and #3. Parties may obtain this information by signing a non-disclosure agreement.**

Verizon: EIS Study - Florida  
 Non-recurring Rate Development  
 Misc Svcs-Labor

Ln	Cost Elements	Increment	Source	Cost
1	Misc Svcs-Labor-Basic Bus Day-First 1/2 Hr	per Technician	Loaded Labor Rates 1-CS	\$ 48.31
2	Misc Svcs-Labor-Basic Bus Day-Each Additional 1/2 Hr	per Technician	Ln 1 * .50 hr	\$ 24.15
3	Misc Svcs-Labor-OT Non-Bus Day - First 1/2 Hr	per Technician	FCC Tariff #1, Section 6, Page 226	\$ 100.00
4	Misc Svcs-Labor-OT Non-Bus Day - Each Additional 1/2 Hr	per Technician	FCC Tariff #1, Section 6, Page 226	\$ 75.00
5	Misc Svcs-Labor-Premium Non-Bus Day - First 1/2 Hr	per Technician	FCC Tariff #1, Section 6, Page 226	\$ 150.00
6	Misc Svcs-Labor-Premium Non-Bus Day - Each Additional 1/2 Hr	per Technician	FCC Tariff #1, Section 6, Page 226	\$ 125.00



Verizon: EIS Study - Florida  
 Non-recurring Cost Development  
 Relay Rack

Ln	Description	Source	Material
1	Equipment Investment	Relay Rack 2-CS	
2	Material Loadings Factor	Material Loading-CS	
3	Material Loadings	Ln 1 * Ln 2	
4	Equipment Costs	Ln 1 + Ln 3	\$ 255.24
5	10 Position Fuse Panel	Relay Rack 2-CS	
6	Material Loadings Factor	Material Loading-CS	
7	Material Loadings	Ln 5 * Ln 6	
8	Equipment Costs	Ln 5 + Ln 7	\$ 391.07
9	Engineering Costs	Relay Rack 2-CS	
10	Installation Costs	Relay Rack 2-CS	
11	Travel Time	Relay Rack 2-CS	

**Highlighted information is redacted for reasons #1, #2 and #3. Parties may obtain this information by signing a non-disclosure agreement.**

Verizon: EIS Study - Florida  
 Non-recurring Cost Development  
 Relay Rack

Material Costs

Item ID	Description	Qty.	Unit Cost	Material Cost
	Average Cost of Relay Rack			
	<b>Relay Rack Total</b>			

Labor Costs	Hours	Loaded Labor Rate	Labor Cost
CO Equipment Engineer			
Equipment Installer			
Travel Time			

Note:

Highlighted information is redacted for reasons #1, #2 and #3. Parties may obtain this information by signing a non-disclosure agreement.

**Verizon: EIS Study - Florida**  
**Non-recurring Cost Development**  
**Telecommunications Equipment Cabinet**

Ln	Description	Source	Material
1	Equipment Investment	Cabinet 2-CS	
2	Material Loadings Factor	Material Loading-CS	
3	Material Loadings	Ln 1 * Ln 2	
	Equipment Costs	Ln 1 + Ln 3	
4	Engineering	Cabinet 2-CS	
5	Installation	Cabinet 2-CS	
6	Travel Time	Cabinet 2-CS	

**Highlighted information is redacted for reasons #1, #2 and #3. Parties may obtain this information by signing a non-disclosure agreement.**

**Verizon: EIS Study - Florida**  
**Non-recurring Cost Development**  
**Telecommunications Equipment Cabinet**

**Material Costs**

No.	Item ID	Description	Qty.	Unit Cost	Total Cost
1.					

Labor Costs	Hours	Loaded Labor Rate	Total Cost
CO Equipment Engineer			
Equipment Installer			

**Travel Time**

Note:

**Highlighted information is redacted for reasons #1, #2 and #3. Parties may obtain this information by signing a non-disclosure agreement.**

Verizon: EIS Study - Florida  
 Monthly Recurring Rate Development  
 Building Modification

Fixed Allocator: 14.09%

Ln	Cost Elements	Increment	Source	Cost (a)	Occupancy Rate (b)	Subtotal (c) = (a) / (b)
<b>Security Access</b>						
1	Card Reader	per reader	Card Reader-CS	\$ 176.18	5	\$ 35.24
2	Controller	per controller	Card Reader-CS	\$ 73.81	5	\$ 14.76
3	Storage Security	per collocation office	Storage Security-CS	\$ 61.82	4	\$ 15.45
<b>Site Modifications (for Construction inside Verizon CO only)</b>						
4	Demolition and Site Work	per request	Site Mod-CS	\$ 29.47	4	\$ 7.37
5	HVAC - Minor	per occurrence	Site Mod-CS	\$ 36.46	1	\$ 36.46
6	Dust Partition	per request	Site Mod-CS	\$ 44.50	1	\$ 44.50
<b>Electrical</b>						
7	Light	per unit	Light Fixture-CS	\$ 21.74	1	\$ 21.74
8	Electrical Outlet	per outlet	Elect Outlet-CS	\$ 19.51	1	\$ 19.51
9	Floor Ground Bar	per bar	Floor Ground Bar-CS	\$ 54.14	4	\$ 13.54
10	<b>Total Incremental Monthly Cost</b>		Sum(Ln 1..Ln 9)			\$ 208.57
11	<b>Contribution Amount</b>		Ln 10 * Fixed Allocator			\$ 29.39
12	<b>Rate Element</b>		Ln 10 + Ln 11			\$ 237.96

Note:

- 1) Occupancy rate was developed to reflect the average number of collocators expected to share certain rate elements. The occupancy rate was based on the average number of collocators in Verizon central offices that had collocators in them.
- 2) Fixed Allocator is a method used by Verizon to recover common costs.

Verizon: EIS Study - Florida  
 Monthly Recurring Cost Development  
 Security Access - Card Reader/Controller

Description	Card Reader with Controller	
	Reader Cost	Controller Cost
California Costs -- Adjusted (Note 2)		
Texas Costs -- Adjusted (Note 3)		
National Average Cost		
Adjustment to Make National Average Specific to Florida (-8%) (Note 1)		
Florida Cost		
Annual Cost Factor (ACFs-CS)		
Total Annual Costs		
Monthly Costs	\$ 176.18	\$ 73.81

Note:

Highlighted information is redacted for reasons #1 and #3. Parties may obtain this information by signing a non-disclosure agreement.

Verizon: EIS Study - Florida  
 Monthly Recurring Cost Development  
 Storage Security

Storage Cabinet Security							
Description	Source	Cost Per Cabinet	Cabinets Per CO	Hasp Lock	Bar-Type Lock	Core Lock	Cost
<b>Equipment</b>							
1	Note 1						
2	Note 1						
3							
Subtotal Storage Cabinet Security							_____

**Labor**

4 Note 1

Rack Storage Security							
Description	Source	Cost Per Cabinet	Cable Locks Per CO		Core Lock	Cost	
<b>Equipment</b>							
5	Note 1						
6	Ln 3 + Ln 4 + Ln 5						
Total Storage Security per CO							_____
7	Annual Cost Factor (ACFs-CS)					_____	
8	Total Annual Cost						
9	Monthly Cost					\$ 61.82	

Note:

Highlighted information is redacted for reasons #1 and #3. Parties may obtain this information by signing a non-disclosure agreement.

Verizon: EIS Study - Florida  
 Monthly Recurring Cost Development  
 Site Modifications

Sites	Site Preparation	Dust Partition	Minor HVAC
California Costs -- Adjusted (Note 2&3)			
Texas Costs -- Adjusted (Note 2&4)			
National Average Cost			
Adjustment to Make National Average Specific to Florida (-8%) (Note 2)			
Florida Cost			
Annual Cost Factor (ACFs-CS)			
Total Annual Cost			
Monthly Cost	\$ 29.47	\$ 44.50	\$ 36.46

Note:

Highlighted information is redacted for reasons #1, #3 and #4. Parties may obtain this information by signing a non-disclosure agreement.



Verizon: EIS Study - Florida  
Monthly Recurring Cost Development  
Electrical Outlet

Individual AC Electrical Outlet

Qty	Material	Labor	Contractor	
			Markup	Total

per LF      per LF

per LF      per LF

\_\_\_\_\_

\_\_\_\_\_

\_\_\_\_\_

\_\_\_\_\_

\$ 19.51      Monthly Costs

Highlighted information is redacted for reasons #1, #3 and #4. Parties may obtain this information by signing a non-disclosure agreement.

Note:

Verizon: EIS Study - Florida  
 Monthly Recurring Cost Development  
 Light Fixture

Individual Lighting Fixture

Qty	Material	Labor	Contractor		Total
			Markup		

per LF      per LF

per LF      per LF

\_\_\_\_\_  
 \_\_\_\_\_  
 \_\_\_\_\_  
 \_\_\_\_\_

\$ 21.74      Monthly Costs

Highlighted information is redacted for reasons #1, #3 and #4. Parties may obtain this information by signing a non-disclosure agreement.

Note:

Verizon: EIS Study - Florida  
 Monthly Recurring Cost Development  
 Floor Ground Bar

Caged/Shared/Sublease Collocation Grounding System

<u>Qty</u>	<u>Material</u>	<u>Labor</u>	<u>Contractor Markup</u>	<u>Total</u>	
				\$ 54.14	Monthly Costs

Note:

Highlighted information is redacted for reasons #1, #2, #3 and #4. Parties may obtain this information by signing a non-disclosure agreement.

Verizon: EIS Study - Florida  
 Monthly Recurring Rate Development  
 Environmental Conditioning

Fixed Allocator: 14.09%

Ln	Cost Elements	Increment	Source	Cost (a)
1	Environmental Conditioning	per 1 amp	Environmental Conditioning 1-CS	\$ 2.81
2	<b>Total Incremental Monthly Cost</b>		Ln 1	\$ 2.81
3	<b>Contribution Amount</b>		Ln 2 * Fixed Allocator	\$ 0.40
4	<b>Rate Element</b>		Ln 2 + Ln 3	<u>\$ 3.21</u>

Note:  
 Fixed Allocator is a method used by Verizon to recover common costs.

**Verizon: EIS Study - Florida  
Monthly Recurring Cost Development  
Environmental Conditioning**

Description	Cost
Average Cost of HVAC per Amp	
Adjustment to Make National Average Specific to Florida (-8%)	_____
Florida Cost	
Annual Cost Factor (ACFs-CS)	_____
Total Annual Cost per Amp	
Monthly Cost per Amp	
Monthly Cost per 1 Amp	\$ 2.81

**Highlighted information is redacted for reasons #3 and #4. Parties may obtain this information by signing a non-disclosure agreement.**

**Verizon: EIS Study - Florida**  
**Monthly Recurring Cost Development**  
**Environmental Conditioning**

**Calculation of HVAC Investment per DC Amp**

---

**Engineering Assumptions**

---

A	BTU/hr equivalent of one ton of air conditioning	BTU/hr	
B	BTU/hr equivalent of one Watt of power	BTU/hr	
C	Conversion of one nominal ton of air conditioning to watt equivalent	watts	$C = A / B$
D	Battery Float Voltage	volts DC	
E	Conversion of one nominal ton of air conditioning to amperage equivalent	amps	$E = C / D$
F	Sensible Cooling Capacity to Nominal Cooling Capacity Factor		
G	Conversion of one nominal ton air conditioning to one sensible ton	amps	$G = E * F$

**Investment Calculation**

---

H	Cost of one ton of air conditioning		
I	Cost of one amp equivalent of air conditioning		$I = H / G$

**Highlighted information is redacted for reasons #3 and #4. Parties may obtain this information by signing a non-disclosure agreement.**

**Verizon: EIS Study - Florida  
Monthly Recurring Cost Development  
Environmental Conditioning**

HVAC Cost Estimate

Item	Description	Unit	\$/ Unit	Quantity	Cost
1					
2					
3					
4					
5					
6					
7					
8					
9					
	Electrical Subtotal				
10					
11					
12					
13					
14					
15					
16					
17					
	Mechanical Subtotal				
	Total Cost Without Factors				
	Factors				
	General Conditions				
	Engineering Fees				
	Total National Cost				
	Cost per ton				

Highlighted information is redacted for reasons #3 and #4. Parties may obtain this information by signing a non-disclosure agreement.

**Verizon: EIS Study - Florida  
Monthly Recurring Cost Development  
Environmental Conditioning - HVAC Costs**

Assumptions:

- 1
- 2
- 3
- 4
- 5
- 6
- 7
  
- 8
- 9
- 10
- 11
  
- 12

**Heat Generation due to Electrical Equipment**

Item	Watts

Heat Loads

Highlighted information is redacted for reasons #3 and #4. Parties may obtain this information by signing a non-disclosure agreement.



Verizon: EIS Study - Florida  
 Monthly Recurring Rate Development  
 Floor Space

Fixed Allocator (FA): 14.09%

Ln	Cost Elements	Increment	Source	Cost	Contribution	
					Amount	Rate Element
				(a)	(b) = (a) * FA	(c) = (a)+(b)
1	Caged Floor Space	per square foot	Floor Space 1-CS	\$ 3.36	\$ 0.47	\$ 3.83
2	Microwave Rooftop Space	per square foot	Floor Space 1-CS	\$ 3.36	\$ 0.47	\$ 3.83
3	Relay Rack Floor Space	per linear foot	Floor Space 1-CS	\$ 14.28	\$ 2.01	\$ 16.29
4	Cabinet Floor Space	per linear foot	Floor Space 1-CS	\$ 19.32	\$ 2.72	\$ 22.04

Note:  
 Fixed Allocator is a method used by Verizon to recover common costs.

Verizon: EIS Study - Florida  
 Monthly Recurring Cost Development  
 Floor Space - Square Footage Calculation

Ln	Description	Source	Width in inches A	Depth in inches B
<b>Floor Space for Relay Rack Calculation</b>				
1	Front of Rack (24 15/16" wide)	Note 1		
2	Inside Distance of Rack (guardrail to guardrail)	Note 1		
3	Front Half-Distance Between Aisles (guardrail to guardrail)	Note 1		
4	Rear Half-Distance Between Aisles (guardrail to guardrail)	Note 1		
5		Width and Depth in Inches	Sum(Ln 1:Ln 4)	
6		Conversion to Feet	Ln 5/12	
7	Square Feet per Linear Foot	Ln 6		
8	CO Floor Space Cost per Square Feet per year	Floor Space 2-CS		
9	Shared Access Additive Cost per Square Foot per year	Floor Space 3-CS		
10		Annual Cost for Floor Space per Square Foot	Ln 8 + Ln 9	
11		Monthly Rate for Floor Space per Square Foot	Ln 10 / 12	
12	Cost of Floor Space incl.Shared Access Area (per linear foot)	Ln 7 * Ln 11		
13	Cost of Floor Space incl.Shared Access Area (per relay rack)	Ln 6A * Ln 12		

**Highlighted information is redacted for reasons #3 and #4. Parties may obtain this information by signing a non-disclosure agreement.**

Verizon: EIS Study - Florida  
 Monthly Recurring Cost Development  
 Floor Space - Square Footage Calculation

Ln	Description	Source	Width in inches A	Depth in inches B
<b>Floor Space for Cabinet Calculation</b>				
14	Front of Cabinet	Note 1		
15	Side of Cabinet	Note 1		
16	Front Access Area	Note 1		
17	Rear Access Area	Note 1		
18		Width and Depth in Inches		
19		Conversion to Feet		
20	Square Feet per Linear Foot	Sum(Ln 14:Ln 17) Ln 18 / 12		
21	CO Floor Space Cost per Square Foot per year	Ln 19		
22	Shared Access Additive Cost per Square Foot per year	Floor Space 2-CS		
23		Floor Space 3-CS		
24		Annual Cost for Floor Space per Square Foot		
		Monthly Rate for Floor Space per Square Foot		
25	Cost of Floor Space incl.Shared Access Area (per linear foot)	Ln 21 +Ln 22 Ln 23 / 12		
26	Cost of Floor Space incl.Shared Access Area (per cabinet)	Ln 20 * Ln 24		
		Ln 19A * Ln 25		

Highlighted information is redacted for reasons #3 and #4. Parties may obtain this information by signing a non-disclosure agreement.



Verizon: EIS Study - Florida  
 Monthly Recurring Cost Development  
 Floor Space - Shared Access Area

No.	State	Total Square Feet	Square Root of Total	3'-0" Walkway	Restroom	Staging Area	Break room	Total Shared	Source
(a)		(b)	(c)	(d)	(e)	(f)	(g)	(h)	

1  
2  
3  
4  
5  
6  
7  
8  
9  
10  
11  
12  
13  
14  
15  
16  
17

18	Percentage of Shared Access Floor Space to Total Floor Space	_____	Ln 17h / Ln 17b
19	Cost per Square Foot of Central Office Floor Space	_____	Floor Space 2-CS
20	Annual Cost per Square Foot of Central Office Floor Space with Shared Access added	_____	Ln 19 / (1 - Ln 18)
21	Shared Access Additive Cost per Square Foot per year	_____	Ln 20 - Ln 19
22	Monthly Cost per Square Foot	_____	Ln 20 / 12

Highlighted information is redacted for reasons #3 and #4. Parties may obtain this information by signing a non-disclosure agreement.



Verizon: EIS Study - Florida  
 Monthly Recurring Rate Development  
 Cable Subduct Space

Fixed Allocator (FA): 14.09%

Ln	Cost Elements	Increment	Source	Incremental Cost (a)	Contribution Amount (b) = (a) * FA	Rate Element (c) = (a) + (b)
1	Cable Subduct Space - Manhole	per subduct	Cable Space 1-CS	\$ 6.76	\$ 0.95	\$ 7.71
2	Cable Subduct Space	per linear foot	Cable Space 1-CS	\$ 0.04	\$ 0.006	\$ 0.05

Note:  
 Fixed Allocator is a method used by Verizon to recover common costs.

Subduct and Conduit Cost Calculation				
Ln	Description	Source	Subduct Calculation per subduct	4" Conduit Calculation per conduit
1	Equipment Investment	Cable Space 3-CS		
2	Material Loadings Factor	Material Loading-CS		
3	Material Loadings	Ln 1 * Ln 2		
4	Installation	Cable Space 3-CS		
5	Total Investment	Ln 1 + Ln 3 + Ln 4		
6	Annual Cost Factor	ACFs-CS		
7	Total Annual Costs	Ln 5 * Ln 6		
8	Monthly Cost per foot	Ln 7 / 12	\$ 0.04	\$ 0.06

Manhole Cost Calculation				
Ln	Description	Source	Subduct Calculation per subduct	4" Conduit Calculation per conduit
1	Equipment Investment	Cable Space 2-CS		
2	Material Loadings Factor	Material Loading-CS		
3	Material Loadings	Ln 1 * Ln 2		
4	Installation	Cable Space 2-CS		
5	Total Investment	Ln 1 + Ln 3 + Ln 4		
6	Annual Cost Factor	ACFs-CS		
7	Total Annual Costs	Ln 5 * Ln 6		
8	Monthly Cost per Subduct or Conduit	Ln 7 / 12	\$ 6.76	\$ 12.83

Highlighted information is redacted for reasons #1 and #3. Parties may obtain this information by signing a non-disclosure agreement.



Verizon: EIS Study - Florida  
 Monthly Recurring Cost Development  
 Cable Space

Ln	Description	Subduct Calculation Source	Subduct Calculation (a)	4" Conduit Calculation (b)	Conduit Calculation Source
<u>Manhole Cost per Subduct</u>					
Manhole Cost - Material					
1	Manhole Material	Note 1			Note 1
2	Number of Ducts	Note 4			
3	Number of Subducts	Note 4			
4	Capital Cost per subduct or conduit - Material	Ln 1(a)/ Ln 2(a)/ Ln 3(a)	\$ 37.47	\$ 112.41	Ln 1A/ Ln 2A
Manhole Cost - Installation					
5	Manhole Installation	Note 2			Note 2
6	Core Drilling per core drill	Note 3			Note 3
7	Number of Ducts	Note 4			
8	Number of Subducts	Note 4			
9	Capital Cost per subduct or conduit - Installation	(Ln 5(a)/ Ln 7(a)/ Ln 8(a)) + Ln 6(a)	\$ 204.53	\$ 289.75	(Ln 5A/Ln 7A) + Ln 6A

Note:

Highlighted information is redacted for reasons #1, #3 and #4. Parties may obtain this information by signing a non-disclosure agreement.

Verizon: EIS Study - Florida  
 Monthly Recurring Cost Development  
 Cable Space

Ln	Description	Subduct Calculation Source	Subduct Calculation (a)	4" Conduit Calculation (b)	Conduit Calculation Source
<u>Conduit Cost per Foot</u>					
Conduit Cost - Material					
1	Conduit Material per Foot per Conduit	Note 1			
2	Number of Subducts	Cable Space 2-CS; Note 4			
3	Capital Cost per subduct - Material	Ln 1(a) / Ln 2(a)			
Conduit Cost - Installation					
4	Conduit Installation per Foot per Conduit	Note 2			
5	Number of Subducts	Cable Space 2-CS; Note 4			
6	Capital Cost per subduct- Installation	Ln 4(a) / Ln 5(a)			
Subduct Cost - Material					
7	Subduct Material per Foot per Subduct	Note 1			
8	Number of Subducts				
9	Capital Cost per subduct - Material	Ln 7(a) / Ln 8(a)			
Subduct Cost - Installation					
10	Subduct Installation per Foot per Subduct	Note 2			
11	Number of Subducts				
12	Capital Cost per subduct- Installation	Ln 10(a)/ Ln 11(a)			
<u>Subduct Costs per Subduct</u>					
13	Total Material Capital Cost for Cable Space	Ln 3a+ Ln 9a			
14	Total Installation Capital Cost for Cable Space	Ln 6a+ Ln 12a			
<u>Conduit Costs per Conduit</u>					
15	Total Material Capital Cost for Cable Space				Ln 1b
16	Total Installation Capital Cost for Cable Space				Ln 4b

Note:

Highlighted information is redacted for reasons #1, #3 and #4. Parties may obtain this information by signing a non-disclosure agreement.

Verizon: EIS Study - Florida  
 Monthly Recurring Rate Development  
 Fiber Cable Vault Splice

Fixed Allocator (FA): 14.09%

Ln	Cost Elements	Increment	Source	Contribution		
				Cost (a)	Amount (b) = (a) * FA	Rate Element (c) = (a) + (b)
1	Fiber Cable Vault Splice-48 Fiber-Material	per splice closure	Cable Vault Splice 3-CS	\$ 10.48	\$ 1.48	\$ 11.95
2	Fiber Cable Vault Splice-96 Fiber-Material	per splice closure	Cable Vault Splice 3-CS	\$ 32.39	\$ 4.56	\$ 36.96

Note:  
 Fixed Allocator is a method used by Verizon to recover common costs.

Verizon: EIS Study - Florida  
 Monthly Recurring Cost Development  
 Cable Vault Splice

DSO 1200 pair			
Ln	Description	Source	Material
1	Equipment Investment	Cable Vault Splice 4-CS	
2	Material Loadings Factor	Material Loading-CS	
3	Material Loadings	Ln 1 * Ln 2	
4	Total Equipment Investment	Ln 1 + Ln 3	
5	MDF Engineer & Installation Labor	Cable Vault Splice 4-CS	
6	Total Equipment and MDF Investment	Ln 4 + Ln 5	
7	Annual Cost Factor	ACFs-CS	
8	Total Annual Cost	Ln 6 * Ln 7	
9	Monthly Cost per DSO Cable Splice Closure	Ln 8 / 12	\$ 519.83

DSO 900 pair			
Ln	Description	Source	Material
10	Equipment Investment	Cable Vault Splice 4-CS	
11	Material Loadings Factor	Material Loading-CS	
12	Material Loadings	Ln 10 * Ln 11	
13	Total Equipment Investment	Ln 10 + Ln 12	
14	MDF Engineer & Installation Labor	Cable Vault Splice 4-CS	
15	Total Equipment and MDF Investment	Ln 13 + Ln 14	
16	Annual Cost Factor	ACFs-CS	
17	Total Annual Cost	Ln 15 * Ln 16	
18	Monthly Cost per DSO Cable Splice Closure	Ln 17 / 12	\$ 378.87

Highlighted information is redacted for reasons #2 and #3. Parties may obtain this information by signing a non-disclosure agreement.

Verizon: EIS Study - Florida  
 Monthly Recurring Cost Development  
 Cable Vault Splice

DS0 600 pair			
Ln	Description	Source	Material
1	Equipment Investment	Cable Vault Splice 4-CS	
2	Material Loadings Factor	Material Loading-CS	
3	Material Loadings	Ln 1 * Ln 2	
4	Total Equipment Investment	Ln 1 + Ln 3	
5	MDF Engineer & Installation Labor	Cable Vault Splice 4-CS	
6	Total Equipment and MDF Investment	Ln 4 + Ln 5	
7	Annual Cost Factor	ACFs-CS	
8	Total Annual Cost	Ln 6 * Ln 7	
9	Monthly Cost per DS0 Cable Splice Closure	Ln 8 / 12	\$ 251.95

DS1 100 pair			
Ln	Description	Source	Material
10	Equipment Investment	Cable Vault Splice 5-CS	
11	Material Loadings Factor	Material Loading-CS	
12	Material Loadings	Ln 10 * Ln 11	
13	Total Equipment Investment	Ln 10 + Ln 12	
14	MDF Engineer & Installation Labor	Cable Vault Splice 5-CS	
15	Total MDF Investment	Ln 13 + Ln 14	
16	Annual Cost Factor	ACFs-CS	
17	Total Annual Cost	Ln 15 * Ln 16	
18	Monthly Cost per DS1 Cable Splice Closure	Ln 17 / 12	\$ 53.25

Highlighted information is redacted for reasons #2 and #3. Parties may obtain this information by signing a non-disclosure agreement.

**Verizon: EIS Study - Florida**  
**Monthly Recurring Cost Development**  
**Cable Vault Splice**

Fiber Cable - 48 fiber			
Ln	Description	Source	Material
1	Equipment Investment	Cable Vault Splice 5-CS	
2	Material Loadings Factor	Material Loading-CS	
3	Material Loadings	Ln 1 * Ln 2	
4	Total Investment	Ln 1 + Ln 3	
5	Annual Cost Factor	ACFs-CS	
6	Total Annual Cost	Ln 4 * Ln 5	
7	Monthly Cost per Fiber Cable Splice Closure	Ln 6 / 12	\$ 10.48

Fiber Cable - 96 fiber			
Ln	Description	Source	Material
8	Equipment Investment	Cable Vault Splice 5-CS	
9	Material Loadings Factor	Material Loading-CS	
10	Material Loadings	Ln 8 * Ln 9	
11	Total Investment	Ln 8 + Ln 10	
12	Annual Cost Factor	ACFs-CS	
13	Total Annual Cost	Ln 11 * Ln 12	
14	Monthly Cost per Fiber Cable Splice Closure	Ln 13 / 12	\$ 32.39

**Highlighted information is redacted for reasons #1 and #3. Parties may obtain this information by signing a non-disclosure agreement.**

Verizon: EIS Study - Florida  
 Monthly Recurring Cost Development  
 Cable Vault Splice

Ln	Description	Source	Cost per Pair/Fiber	Cost per 100pair	Total Cost
<u>DSO Cable - 1200 pair</u>					
Equipment					
1					
2					
3					
4					
5					
6					
7	Total Equipment	Sum(Ln 1:Ln 6)			
8					
<u>DSO Cable - 900 pair</u>					
Equipment					
9					
10					
11					
12					
13					
14					
15	Total Equipment	Sum(Ln 9:Ln 14)			
16					
<u>DSO Cable - 600 pair</u>					
Equipment					
17					
18					
19					
20					
21					
22					
23		Sum(Ln 17:Ln 22)			
24					

Note:

Highlighted information is redacted for reasons #1, #2 and #3. Parties may obtain this information by signing a non-disclosure agreement.

Verizon: EIS Study - Florida  
 Monthly Recurring Cost Development  
 Cable Vault Splice

Ln	Description	Source	Cost per Pair/Fiber	Cost per 100pair	Total Cost
<hr/>					
DS1 Cable - 100 pair					
<b>Equipment</b>					
1					
2					
3					
4					
5					
6					
7	Total Equipment	Sum(Ln 1:Ln 6)			<hr/>
8					
<hr/>					
Fiber Cable - 48 fiber					
<b>Equipment</b>					
9					
10					
11					
12					<hr/>
13	Total Equipment	Ln 10 * Ln 11 Ln 9 + Ln 12			
<hr/>					
Fiber Cable - 96 fiber					
<b>Equipment</b>					
14					
15					
16					
17	Total Tray Splice	Ln 15 * Ln 16			<hr/>
18	Total Equipment	Ln 14 + Ln 17			

Note:

Highlighted information is redacted for reasons #1, #2 and #3. Parties may obtain this information by signing a non-disclosure agreement.



**Frame Cost Calculation**

Ln	Description	Per Increment	Loaded Labor Rates	Hours	Total Cost
1					
2					
3					
4					
5					
6					
7					
8					
9					
10					
11					
12					

NO Loadings      Eng & Install  
Equipment Only      Only

Highlighted information is redacted for reasons #1, #2 and #3. Parties may obtain this information by signing a non-disclosure agreement.



Verizon: EIS Study - Florida  
 Monthly Recurring Rate Development  
 Cable Vault Space

Fixed Allocator (FA): 14.09%

Ln	Cost Elements	Increment	Source	Incremental Cost (a)	Contribution Amount (b) = (a) * FA	Rate Element (c) = (a)+(b)
1	Adjacent Cable Vault Space (per 1200 pr)	per cable	Cable Vault Space 1-CS	\$ 4.78	\$ 0.67	\$ 5.45
2	Adjacent Cable Vault Space (per 900 pr)	per cable	Cable Vault Space 1-CS	\$ 3.68	\$ 0.52	\$ 4.20
3	Adjacent Cable Vault Space (per 600 pr)	per cable	Cable Vault Space 1-CS	\$ 2.63	\$ 0.37	\$ 3.00
4	Adjacent Cable Vault Space (per 100 pr)	per cable	Cable Vault Space 1-CS	\$ 0.60	\$ 0.08	\$ 0.68
5	Cable Vault Space (fiber)	per subduct	Cable Vault Space 1-CS	\$ 1.23	\$ 0.17	\$ 1.40

Note:  
 Fixed Allocator is a method used by Verizon to recover common costs.

Verizon: EIS Study - Florida  
Monthly Recurring Cost Development  
Cable Vault Space

Cable Vault Space				
Ln	Description	Source	Diameter In Inches	Monthly Cost Per Cable
1	Metallic DS0 Cable - 1200 pair	Note 1		
2	Metallic DS0 Cable - 900 pair	Note 1		
3	Metallic DS0 Cable - 600 pair	Note 1		
4	Metallic DS1 Cable	Note 1		
5	Fiber Cable	Note 1, 2		

Note:

**Highlighted information is redacted for reasons #1 and #3. Parties may obtain this information by signing a non-disclosure agreement.**

Verizon: EIS Study - Florida  
 Monthly Recurring Cost Development  
 Cable Vault Space

Cable Vault Space Calculations - Metallic DS0 Cable - 1200 pair

Ln	Description	Source	Unit	Hours per Unit
<u>Cubic Feet Utilized</u>				
1	Diameter of Cable	Note 1	Inches	
2	Diameter of Cable (in Feet)	Ln 1 / 12	Feet	
3	Length of Cable Vault	Note 2	Feet	
4	Radius of Cable	Ln 2 / 2	Feet	
5	Area of Width of Cable	Pi * (Ln 4) <sup>2</sup>	Feet	
6	Volume of Cable	Ln 3 * Ln 5	Cubic Feet	
<u>Cost per Cubic Foot</u>				
7	Cost of Cable Vault		Note 3	
8	Cubic Feet for Unistrut / Extenders	Cable Vault Space 7-CS	Cubic Feet	
9	Cost per Cubic Foot			
<u>Cost for Cable Vault Space Utilized</u>				
10	Cost per Cubic Foot		Cost per Cubic Foot	
11	Volume of Cable		Cubic Ft per Cable	
12	Cost for Cable Vault Space Utilized per Cable		Cost per Cable	
13	Annual Cost Factor - #212100		ACFs	
14	Total Annual Cost		Ln 12 * Ln 13	
15	Monthly Cost for Cable Vault Space Utilized per Cable		Ln 14 / 12	\$ 4.78

Highlighted information is redacted for reasons #1 and #3. Parties may obtain this information by signing a non-disclosure agreement.

Verizon: EIS Study - Florida  
 Monthly Recurring Cost Development  
 Cable Vault Space

Cable Vault Space Calculations - Metallic DSO Cable - 900 pair				
Ln	Description	Source	Unit	Hours per Unit
<u>Cubic Feet Utilized</u>				
1	Diameter of Cable	Note 1	Inches	
2	Diameter of Cable (in Feet)	Ln 1 / 12	Feet	
3	Length of Cable Vault	Note 2	Feet	
4	Radius of Cable	Ln 2 / 2	Feet	
5	Area of Width of Cable	$\text{Pi} * (\text{Ln } 4)^2$	Feet	
6	Volume of Cable	$\text{Ln } 3 * \text{Ln } 5$	Cubic Feet	
<u>Cost per Cubic Foot</u>				
7	Cost of Cable Vault		Note 3	
8	Cubic Feet for Unistrut / Extenders	Cable Vault Space 7-CS	Cubic Feet	
9	Cost per Cubic Foot			
<u>Cost for Cable Vault Space Utilized</u>				
10	Cost per Cubic Foot		Cost per Cubic Foot	
11	Volume of Cable		Cubic Ft per Cable	
12	Cost for Cable Vault Space Utilized per Cable		Cost per Cable	
13	Annual Cost Factor - #212100		ACFs	
14	Total Annual Cost		$\text{Ln } 12 * \text{Ln } 13$	
15	Monthly Cost for Cable Vault Space Utilized per Cable		$\text{Ln } 14 / 12$	\$ 3.68

Highlighted information is redacted for reasons #1 and #3. Parties may obtain this information by signing a non-disclosure agreement.

Verizon: EIS Study - Florida  
 Monthly Recurring Cost Development  
 Cable Vault Space

Cable Vault Space Calculations - Metallic DS0 Cable - 600 pair

Ln	Description	Source	Unit	Hours per Unit
<u>Cubic Feet Utilized</u>				
1	Diameter of Cable	Note 1	Inches	
2	Diameter of Cable (in Feet)	Ln 1 / 12	Feet	
3	Length of Cable Vault	Note 2	Feet	
4	Radius of Cable	Ln 2 / 2	Feet	
5	Area of Width of Cable	Pi * (Ln 4) <sup>2</sup>	Feet	
6	Volume of Cable	Ln 3 * Ln 5	Cubic Feet	
<u>Cost per Cubic Foot</u>				
7	Cost of Cable Vault		Note 3	
8	Cubic Feet for Unistrut / Extenders	Cable Vault Space 7-CS	Cubic Feet	
9	Cost per Cubic Foot			
<u>Cost for Cable Vault Space Utilized</u>				
10	Cost per Cubic Foot		Cost per Cubic Foot	
11	Volume of Cable		Cubic Ft per Cable	
12	Cost for Cable Vault Space Utilized per Cable		Cost per Cable	
13	Annual Cost Factor - #212100		ACFs	
14	Total Annual Cost		Ln 12 * Ln 13	
15	Monthly Cost for Cable Vault Space Utilized per Cable		Ln 14 / 12	\$ 2.63

Highlighted information is redacted for reasons #1 and #3. Parties may obtain this information by signing a non-disclosure agreement.

Verizon: EIS Study - Florida  
 Monthly Recurring Cost Development  
 Cable Vault Space

Cable Vault Space Calculations - Metallic DS1 Cable - 100 pair				
Ln	Description	Source	Unit	Hours per Unit
<u>Cubic Feet Utilized</u>				
1	Diameter of Cable	Note 1	Inches	
2	Diameter of Cable (in Feet)	Ln 1 / 12	Feet	
3	Length of Cable Vault	Note 2	Feet	
4	Radius of Cable	Ln 2 / 2	Feet	
5	Area of Width of Cable	Pi * (Ln 4) <sup>2</sup>	Feet	
6	Volume of Cable	Ln 3 * Ln 5	Cubic Feet	
<u>Cost per Cubic Foot</u>				
7	Cost of Cable Vault		Note 3	
8	Cubic Feet for Unistrut / Extenders	Cable Vault Space 7-CS	Cubic Feet	
9	Cost per Cubic Foot			
<u>Cost for Cable Vault Space Utilized</u>				
10	Cost per Cubic Foot		Cost per Cubic Foot	
11	Volume of Cable		Cubic Ft per Cable	
12	Cost for Cable Vault Space Utilized per Cable		Cost per Cable	
13	Annual Cost Factor - #212100		ACFs	
14	Total Annual Cost		Ln 12 * Ln 13	
15	Monthly Cost for Cable Vault Space Utilized per Cable		Ln 14 / 12	\$ 0.60

Highlighted information is redacted for reasons #1 and #3. Parties may obtain this information by signing a non-disclosure agreement.



Verizon: EIS Study - Florida  
 Monthly Recurring Cost Development  
 Cable Vault Space

Cable Vault Space Calculations - Fiber Cable				
Ln	Description	Source	Unit	Hours per Unit
<u>Cubic Feet Utilized</u>				
1	Diameter of Cable	Note 1	Inches	
2	Diameter of Cable (in Feet)	Ln 1 / 12	Feet	
3	Length of Cable Vault	Note 2	Feet	
4	Radius of Cable	Ln 2 / 2	Feet	
5	Area of Width of Cable	$\text{Pi} * (\text{Ln } 4)^2$	Feet	
6	Volume of Cable	$\text{Ln } 3 * \text{Ln } 5$	Cubic Feet	
<u>Cost per Cubic Foot</u>				
7	Cost of Cable Vault		Note 3	
8	Cubic Feet for Unistrut / Extenders	Cable Vault Space 7-CS	Cubic Feet	
9	Cost per Cubic Foot			
<u>Cost for Cable Vault Space Utilized</u>				
10	Cost per Cubic Foot		Cost per Cubic Foot	
11	Volume of Cable		Cubic Ft per Cable	
12	Cost for Cable Vault Space Utilized per Cable		Cost per Cable	
13	Annual Cost Factor - #212100		ACFs	
14	Total Annual Cost		$\text{Ln } 12 * \text{Ln } 13$	
15	Monthly Cost for Cable Vault Space Utilized per Cable		$\text{Ln } 14 / 12$	\$ 1.23

Highlighted information is redacted for reasons #1 and #3. Parties may obtain this information by signing a non-disclosure agreement.

Verizon: EIS Study - Florida  
 Monthly Recurring Cost Development  
 Cable Vault Space

Cable Vault Space Calculations - Unistrut and Extenders				
Ln	Description	Source	Unit	Hours per Unit
<u>Cubic Feet Occupied by Unistrut / Extenders</u>				
1	Width of Extenders	Note 1	Feet	
2	Height of Unistrut	Note 2	Feet	
3	Length of Cable Vault	Note 3	Feet	
4	Number of Unistruts	Note 4		
5	Cubic Feet for Unistrut / Extenders	$Ln\ 1 * Ln\ 2 * Ln\ 3 * Ln\ 4$		

**Highlighted information is redacted for reason #3. Parties may obtain this information by signing a non-disclosure agreement.**

Verizon: EIS Study - Florida  
 Monthly Recurring Rate Development  
 Cable Rack Shared Space - Metallic

Fixed Allocator: 14.09%

Ln	Cost Elements	Increment	Source	Cost (a)	Units (b)	Frequency (c)	Subtotal (d) = (a)*(b)*(c)
<b>Cable Rack Shared Space</b>							
1	Cable Rack Shared Space-DS0	per cable run	Cable Rack Space 1-CS	\$ 0.0035	73	0.33	\$ 0.09
2	Cable Rack Shared Space-DS1	per cable run	Cable Rack Space 1-CS	\$ 0.0022	73	0.33	\$ 0.05
3	Cable Rack Shared Space-Coaxial	per cable run	Cable Rack Space 1-CS	\$ 0.0007	73	0.33	\$ 0.02
4	<b>Total Incremental Monthly Cost</b>		Sum(Ln 1.. Ln 3)				\$ 0.15
5	<b>Contribution Amount</b>		Ln 4 * Fixed Allocator				\$ 0.02
6	<b>Rate Element</b>		Ln 4 + Ln 5				\$ 0.18

Note:

- 1) The units for DS0, DS1 and DS3 cables are based on the average linear feet of cable for 59 central offices less 39 linear feet used in the Overhead Superstructure calculation.
- 2) Frequency was developed to reflect the weighting of these three costs into one rate element.
- 3) Fixed Allocator is a method used by Verizon to recover common costs.

Verizon: EIS Study - Florida  
 Monthly Recurring Rate Development  
 Cable Rack Shared Space - Fiber

Fixed Allocator: 14.09%

Ln	Cost Elements	Increment	Source	Cost
1	Cable Rack Shared Space-Fiber	per innerduct ft	Cable Rack Space 1-CS	\$ 0.0049
2	Total Incremental Monthly Cost		Ln 1	<u>\$ 0.0049</u>
3	Contribution Amount		Ln 2 * Fixed Allocator	<u>\$ 0.0007</u>
4	Rate Element		Ln 2 + Ln 3	<u><u>\$ 0.0056</u></u>

Note:

Fixed Allocator is a method used by Verizon to recover common costs.

**Verizon: EIS Study - Florida**  
**Monthly Recurring Cost Development**  
**Cable Rack Shared Space**

Cable Rack Shared Space				
Ln	Description	Source	Unit	Costs
1	Annual Cost per 100-pair cable	Cable Rack Space 2-CS	Foot	
2	Monthly Cost per 100-pair cable	Ln 1 / 12	Foot	
3	Annual Cost per 28-pair cable	Cable Rack Space 2-CS	Foot	
4	Monthly Cost per 28-pair cable	Ln 3 / 12	Foot	
5	Annual Cost per Fiber cable	Cable Rack Space 2-CS	Foot	
6	Monthly Cost per Fiber cable	Ln 5 / 12	Foot	
7	Annual Cost per Coaxial cable	Cable Rack Space 2-CS	Foot	
8	Monthly Cost per Coaxial cable	Ln 7 / 12	Foot	

Note:

**Highlighted information is redacted for reasons #1 and #3. Parties may obtain this information by signing a non-disclosure agreement.**

Verizon: EIS Study - Florida  
 Monthly Recurring Cost Development  
 Cable Rack Shared Space

Cable Rack Shared Space Calculations				
Ln	Description	Source	Unit	Dimensions/Costs
Cubic Feet Utilized				
1	Diameter of 100-pair cable	Note 1	Inches	
2	# of 100-pair cable in 24" cable rack	Note 1	100-pair cable	
3	Diameter of 28-pair cable	Note 2	Inches	
4	# of 28-pair cable in 24 " cable rack	(Ln 1/Ln 3) * Ln 2	28-pair cable	
5	Diameter of Fiber cable	Note 2	Inches	
6	# of innerduct in 24 " cable rack	(Ln 1/Ln 5) * Ln 2	Innerduct	
7	Diameter of Coaxial cable	Note 2	Inches	
8	# of coaxial cable in 24 " cable rack	(Ln 1/Ln 7) * Ln 2	Coaxial cable	
Cost per Foot for Cable Rack Shared Space				
9	Cable Rack - Equipment	NRC Overhead Superstructure 1-CS	Feet	
10	Cable Rack - Installation	NRC Overhead Superstructure 1-CS	Feet	
11	Cost per Foot	Sum (Ln 9 : Ln10)		
12	Annual Cost Factor	ACFs - 1		
13	Total Annual Cost per foot	Ln 13 * Ln 14		
Annual Cost for Cable Rack Shared Space				
14	Annual Cost per 100-pair cable	Ln 15 / Ln 2	Foot	
15	Annual Cost per 28-pair cable	Ln 15 / Ln 4	Foot	
16	Annual Cost per Fiber cable	Ln 15 / Ln 6	Foot	
17	Annual Cost per Coaxial cable	Ln 15 / Ln 8	Foot	

Note:

Highlighted information is redacted for reasons #1 and #3. Parties may obtain this information by signing a non-disclosure agreement.

Verizon: EIS Study - Florida  
 Monthly Recurring Rate Development  
 DC Power

Fixed Allocator: 14.09%

Ln	Cost Elements	Increment	Source	Cost
<b>DC Power</b>				
1	DC Power - Power Supply	per 1 amps	DC Power Fac 1-CS	\$ 17.69
2	DC Power - Fuses and Fuse Panels (BDFB)	per 1 amps	DC Power Fac 1-CS	\$ 0.38
3	DC Power - Power Cable Pull - Labor	per 1 amps	DC Power Fac 1-CS	\$ 1.22
4	DC Power Utility	per 1 amps	DC Power Util 1-CS	\$ 3.02
5	<b>Total Incremental Monthly Cost</b>		Sum(Ln 1.. Ln 4)	\$ 22.31
6	<b>Contribution Amount</b>		Ln 5 * Fixed Allocator	\$ 3.14
7	<b>Rate Element</b>		Ln 5 + Ln 6	<u>\$ 25.45</u>

Note:  
 Fixed Allocator is a method used by Verizon to recover common costs.

Verizon: EIS Study - Florida  
 Monthly Recurring Cost Development  
 DC Power Facility

Ln	Description	Source	Power Supply Cost (per 1 amps) (a)	BDFB Fuses and Fuses Panels (per 1 amps) (b)	Power Cable Pull (per 1 amps) (c)
1	Equipment Investment	DC Power Fac 3,2-CS			
2	Installation Factor	EF&I-CS			
3	Installation Amount	DC Power Fac 3, Ln 1 * Ln 2			
4	Total Investment	Ln 1 + Ln 3			
5	Annual Cost Factor	ACFs-CS			
6	Total Annual Costs	Ln 4 * Ln 5			
7	Floor Space Cost per BDFB	DC Power Fac 2-CS			
8	Monthly Cost	Ln 6 / 12 + Ln 7	\$ 17.69	\$ 0.38	\$ 1.22

Highlighted information is redacted for reasons #1 and #3. Parties may obtain this information by signing a non-disclosure agreement.



Verizon: EIS Study - Florida  
 Monthly Recurring Cost Development  
 DC Power BDFB Material/Labor Cost

Ln	Description	Source	Hours	Rate	Total Cost	Unit Cost (a) = Note 1	Quantity (b) = Note 1	Calculation (c)= (a)*(b)
	BDFB Material							
	Fuse and Fuse Position	DC Power Fac 5-CS				per amp	1 amps	
	Floor Space Cost per Relay Rack							
	Two BDFBs per Relay Rack							
	Floor Space Cost per BDFB					per amp	1 amps	
	Power Cable Costs	DC Power Fac 5-CS				per amp	1 amps	
	Connector Taps	DC Power Fac 5-CS				per amp	1 amps	
	Total							

Note:

Highlighted information is redacted for reasons #1 and #3. Parties may obtain this information by signing a non-disclosure agreement.

Verizon: EIS Study - Florida  
 Monthly Recurring Cost Development  
 DC Power Facility - Equipment and Labor Costs

Description			Power Equipment		Power Install	
CO Line Sizes	Amps	Line %	Power Equipment Cost	Cost per Amp	Power Install Cost	Cost per Amp
	(a)	(b)	(c)	(d)=(c)/(a)*(b)	(e)	(f)=(e)/(a)*(b)

Total per Amp

1 Amp Total

Note:

Highlighted information is redacted for reasons #1 and #3. Parties may obtain this information by signing a non-disclosure agreement.

Verizon Engineering Planning Guidelines

Line Size	Power Equipment						Total	Installation Factor	Installation Amount	Total Inv Amount	Per Line
	Generator	Rectifier	Batteries	Pwr Bd	Misc	Inverter					
Small Switch											
Medium Switch	Up to:										
Large Switch	Up to:										
Remotes											
Small	Up to:										
Large	Up to:										

Power Investment Per Cost Study Line Size

Size	Base/Host		Pwr Install	Total EF&I
	Pwr Eqpt			

Size	Remote		
	Pwr Eqpt	Pwr Install	Total EF&I

Mapping Criteria  
 Small Sw  
 Small Sw  
 Small Sw  
 Small Sw  
 Medium Sw  
 Large Sw  
 Large Sw+add'l rect/batt  
 Large Sw+add'l rect/batt  
 +add'l pwr bd

Note:

Highlighted information is redacted for reasons #1 and #3. Parties may obtain this information by signing a non-disclosure agreement.

**Verizon: EIS Study - Florida**  
**Monthly Recurring Cost Development**  
**DC Power Facility - Equipment and Labor Costs**

Power Cost for Provisioning BDFB

Ln	Description	Quantity	Cost	Total Cost	Cost/AMP Based on 480
<b>Battery Distribution Fuse Bay</b>					
RELTEC 1293B2					
1	Dual Load Common Equipment				
2	Analog meter panel				
3	DC/600A Analog metering				
4	Distribution Fuse Panel				
5	E/W (8) 31-60A Fuse Positions 2 Panels "A" and 2 Panels "B"				
6	<b>Total Equipment</b>				

**Cable Costs**

		Quantity	
		Feet	Runs
			Cost/ft
7	750 MCM Flexible Power Cable		
	Based on 125' runs from Main Power		
8	Connector Taps 750MCM		

**Highlighted information is redacted for reasons #1 and #3. Parties may obtain this information by signing a non-disclosure agreement.**

Verizon: EIS Study - Florida  
 Monthly Recurring Cost Development  
 DC Power Utility

Ln	Description	Source	Calculation
1	Amperage Rating of Equipment (AMPS)		
2	Voltage Rating of Equipment (Volts)	DC Power Util 2-Cs	
3	Equipment Power Requirement	(Ln 1 * Ln 2) / 1000	
4	Florida Cost of Commercial Electricity (\$/KWH)	DC Power Util 3-CS	
5	Hourly Cost to Power Equipment	Ln 3 * Ln 4	
6	Hours per Day		
7	Days per Year		
8	Annual Cost to Power Equipment	Ln 5 * Ln 6 * Ln 7	
9	Efficiency and Heat Loss Factor	DC Power Util 2-Cs	
10	Annual Power Cost Corrected for Power Loss	Ln 8 * Ln 9	
11	Monthly Power Cost	Ln 10/12	\$ 3.02

Note:

**Highlighted information is redacted for reasons #1 and #3. Parties may obtain this information by signing a non-disclosure agreement.**

Verizon: EIS Study - Florida  
Monthly Recurring Cost Development  
DC Power Utility

**DC Power Engineering Calculations:**

Power In (PI)      Power Factor (PF)      Power Out (PO)

Rectifier Amps  
Rectifier Voltage

**Efficiency & Heat Loss Factor**

Ratio Formula: Power In divided by Power Out (PI/PO)

Power In      Power Out

Ratio

**Highlighted information is redacted for reason #3. Parties may obtain this information by signing a non-disclosure agreement.**

Verizon: EIS Study - Florida  
Monthly Recurring Cost Development  
Cost per Kilo Watt Hour

State	2001 Cost Per kwh
AL	
AZ	
CA	
CT	
DC	
DE	
FL	
HI	
ID	
IL	
IN	
KY	
MA	
MD	
ME	
MI	
MO	
NC	
NH	
NJ	
NY	
NV	
OH	
OR	
PA	
RI	
SC	
TX	
VA	
VT	
WA	
WI	
WV	

Note:

Highlighted information is redacted for reason #3. Parties may obtain this information by signing a non-disclosure agreement.

Verizon: EIS Study - Florida  
 Monthly Recurring Rate Development  
 Facility Termination

Fixed Allocator (FA): 14.09%

Ln	Cost Elements	Increment	Source	Contribution		
				Cost	Amount	Rate Element
				(a)	(b) = (a) * FA	(c) = (a)+(b)
1	Facility Termination-DS0	per 100 pr	Facility Term 1-CS	\$ 2.81	\$ 0.40	\$ 3.21
2	Facility Termination-DS1	per 28 pr	Facility Term 3-CS	\$ 9.18	\$ 1.29	\$ 10.47
3	Facility Termination-DS3	per coaxial cable	Facility Term 5-CS	\$ 22.01	\$ 3.10	\$ 25.11

Note:  
 Fixed Allocator is a method used by Verizon to recover common costs.



Verizon: EIS Study - Florida  
 Monthly Recurring Cost Development  
 Facility Termination: DS0

DS0			
Ln	Description	Source	Material
1	Equipment Investment	Fac Term 2-CS	
2	Installation Factor	EF&I-CS	
3	Installation Amount	Ln 1 * Ln 2	
4	Total Investment	Ln 1 + Ln 3	
5	Annual Cost Factor	ACFs-CS	
6	Total Annual Costs	Ln 4 * Ln 5	
7	Monthly Cost per 100 pair DS0 Cable	Ln 6 / 12	\$ 2.81

**Highlighted information is redacted for reasons #1 and #3. Parties may obtain this information by signing a non-disclosure agreement.**

Verizon: EIS Study - Florida  
 Monthly Recurring Cost Development  
 Facility Termination: DS0

Ln	Description	Source	Loaded Labor Rate	Hours	Calculation
<u>Material</u>					
1	Block Connector 100 Pair Cost	Note 1			
2	Main Distribution Frame (Per DS0 Pair) Cost	Cable Vault Splice 6-CS			
3	Number of DS0 Pairs				
4	MDF Cost for 100 Pair DS0	Ln 2 * Ln 3			
5	Total Material Cost	Ln 1 + Ln 4			<b>\$ 86.92</b>

Note:

Highlighted information is redacted for reasons #1 and #3. Parties may obtain this information by signing a non-disclosure agreement.

Verizon: EIS Study - Florida  
 Monthly Recurring Cost Development  
 Facility Termination: DS1

DS1			
Ln	Description	Source	Material
1	Equipment Investment	Fac Term 4-CS	
2	Installation Factor	EF&I-CS	
3	Installation Amount	Ln 1 * Ln 2	
4	Total Investment	Ln 1 + Ln 3	
5	Annual Cost Factor	ACFs-CS	
6	Total Annual Costs	Ln 4 * Ln 5	
7	Floor Space Cost per Relay Rack per DS1	Fac Term 4-CS	
8	Monthly Cost	Ln 6 / 12 + Ln 7	\$ 9.18

Note:

Highlighted information is redacted for reasons #1 and #3. Parties may obtain this information by signing a non-disclosure agreement.

Verizon: EIS Study - Florida  
 Monthly Recurring Cost Development  
 Facility Termination: DS1

Ln	Description	Source	Loaded Labor Rate	Hours	Calculation
<b>Material</b>					
1	56 Circuit DSX1 Panel Cost	Note 1			
2	Number of 28 pair DS1s in 56 DSX Panel				
3	DSX Panel Cost per DS1	Ln 1 / Ln 2			
4	Relay Rack				
5	Total Relay Rack Cost	Relay Rack 2-CS			
6	Number of DSX Panels per Rack				
7	Number of 28 pair DS1s in 56 DSX Panel				
8	Total Relay Rack Cost per 28 pair DS1	Ln 5 / Ln 6 / Ln 7			
9	Total Material per 28 pair DS1 Cost	Ln 3 + Ln 8			\$ 245.71
10	Floor Space Cost per Relay Rack				
11	Floor Space Cost per Relay Rack	Note 2			
12	Number of DSX Panels per Rack				
13	Number of 28 pair DS1s in 56 DSX Panel				
14	Total Floor Space Cost per Relay Rack per DS1	Ln 11 / Ln 12 / Ln 13			\$ 1.24

Note:

Highlighted information is redacted for reasons #1 and #3. Parties may obtain this information by signing a non-disclosure agreement.

Verizon: EIS Study - Florida  
 Monthly Recurring Cost Development  
 Facility Termination: DS3

DS3			
Ln	Description	Source	Material
1	Equipment Investment	Fac Term 6-CS	
2	Installation Factor	EF&I-CS	
3	Installation Amount	Ln 1 * Ln 2	
4	Total Investment	Ln 1 + Ln 3	
5	Annual Cost Factor	ACFs-CS	
6	Total Annual Costs	Ln 4 * Ln 5	
7	Floor Space Cost per Relay Rack per DS3	Fac Term 6-CS	
8	Monthly Cost	Ln 6 / 12 + Ln 7	\$ 22.01

Note:

**Highlighted information is redacted for reasons #1 and #3. Parties may obtain this information by signing a non-disclosure agreement.**

Verizon: EIS Study - Florida  
 Monthly Recurring Cost Development  
 Facility Termination: DS3

Ln	Description	Source	Loaded Labor Rate	Hours	Calculation
<u>Material</u>					
1	DS3 Cross Connect Chassis Cost	Note 1			
2	Number of Slots per Chassis				
3	DS3 Cross Connect Cost per Slot	Ln 1 / Ln 2			
4	DS3 Cross Connect - Module (Each DS3 Circuit)	Note 1			
5	Subtotal Chassis Slot and Module Cost	Ln 3 + Ln 4			
6	Number of DS3 per Module				
7	Subtotal Chassis and Module Cost per DS3	Ln 5 * Ln 6			
8	Relay Rack				
9	Total Relay Rack Cost	Relay Rack 2-CS			
10	Number of Chassis per Rack				
11	Number of DS3s per Chassis				
12	Subtotal Relay Rack Cost per DS3	Ln 9 / Ln 10 / Ln 11			
13	Total Material	Ln 7 + Ln 12			
14	Floor Space Cost per Relay Rack				
15	Floor Space Cost per Relay Rack	Floor Space 1-CS			
16	Number of Chassis per Rack				
17	Number of DS3s per Chassis				
18	Subtotal Floor Space Cost per Relay Rack per DS3	Ln 15 / Ln 16 / Ln 17			

Note:

Highlighted information is redacted for reasons #1 and #3. Parties may obtain this information by signing a non-disclosure agreement.

Verizon: EIS Study - Florida  
 Monthly Recurring Rate Development  
 BITS Timing

Fixed Allocator: 14.09%

Ln	Cost Elements	Increment	Source	Cost
1	BITS Timing	per port	BITS Timing 1-CS	\$ 9.01
2	<b>Total Incremental Monthly Cost</b>		Ln 1	<u>\$ 9.01</u>
3	<b>Contribution Amount</b>		Ln 2 * Fixed Allocator	\$ 1.27
4	<b>Rate Element</b>		Ln 3 + Ln 2	<u><u>\$ 10.28</u></u>

Note:  
 Fixed Allocator is a method used by Verizon to recover common costs.

Verizon: EIS Study - Florida  
 Monthly Recurring Cost Development  
 BITS Timing

BITS Timing per Port			
Ln	Description	Source	Calculation
1	Equipment Investment	BITS Timing 2-CS	
2	Installation Factor	EF&I-CS	
3	Installation Amount	Ln 1 * Ln 2	
4	Total Investment	Ln 1 + Ln 3	
5	Annual Cost Factor	ACFs-CS	
6	Total Annual Costs	Ln 4 * Ln 5	
7	Monthly Cost per port	Ln 6 / 12	\$ 9.01

Note:

**Highlighted information is redacted for reasons #1 and #3. Parties may obtain this information by signing a non-disclosure agreement.**



Verizon: EIS Study - Florida  
 Monthly Recurring Cost Development  
 Bits Timing Equipment

Bits Timing Cost Calculation - Material					
Ln	Description	Quantity (a)	Unit Price (b)	Source (c)	Total Cost (d) = (a)*(b)
Material					
1	Shelf Master DCD-519 e/w WW PNL				
2	Shelf EXP DCD-519 e/w WW Panel				
3	Unit Clock Input (CI)				
4	Clock ST2E				
5	Controller Matrix (MCA 5)				
6	Interface Maintenance RS-232				
7	Interface Sys Alarm (SAI)				
8	Unit Output Automatic (TOCA)				
9	Unit T1 Output Automatic (TOTA)				
10	Shelf DCD-LPRS				
11	Kit GPS Timing T1 Verizon				
12	Cables 2 Fiber w/Conn, 200'				
13	Cable GPS Power, 200'				
14	Unit Blank LPR				
15	KIT Isolation Module				
16	Total Material Cost				
17	Number of ports per system				
	Material Cost per Port			Ln 16D / Ln 17A	\$ 278.75

Note:

Highlighted information is redacted for reasons #1 and #3. Parties may obtain this information by signing a non-disclosure agreement.

Verizon: EIS Study - Florida  
 Monthly Recurring Rate Development  
 Facility Termination - Fiber Optic Patchcord

Fixed Allocator: 14.09%

Ln	Cost Elements	Increment	Source	Cost
1	Fiber Optic Patchcord - Termination	per connector	Fac Term - Fiber Optic 1-CS	\$ 0.41
2	<b>Total Incremental Monthly Cost</b>		Ln 1	<u>\$ 0.41</u>
3	<b>Contribution Amount</b>		Ln 2 * Fixed Allocator	\$ 0.06
4	<b>Rate Element</b>		Ln 2 + Ln 3	<u><u>\$ 0.47</u></u>

Note:  
 Fixed Allocator is a method used by Verizon to recover common costs.

Verizon: EIS Study - Florida  
 Monthly Recurring Cost Development  
 Facility Termination - Fiber Optic Patchcord

Ln	Description	Source	Material
1	Equipment Investment per Connector	Fac Term - Fiber Optic 2-CS	
2	Installation Factor	EF&I-CS	
3	Installation Amount	Ln 1 * Ln 2	_____
4	Total Investment per Connector	Ln 1 + Ln 3	_____
5	Annual Cost Factor	ACFs-CS	
6	Total Annual Costs	Ln 4 * Ln 5	
7	Floor Space Cost per Connector	Fac Term - Fiber Optic 2-CS	
8	Monthly Cost per Connector	Ln 6 / 12 + Ln 7	_____

**Highlighted information is redacted for reasons #1 and #3. Parties may obtain this information by signing a non-disclosure agreement.**

Verizon: EIS Study - Florida  
 Monthly Recurring Cost Development  
 Facility Termination - Fiber Optic Patchcord

Ln	Description	Source	Loaded Labor Rate	Hours	Calculation
<u>Material</u>					
1	Optical Cross Connect Chassis Cost	Note 1			
2	Number of Cards per Chassis	Note 1			
3	Optical Cross Connect Chassis Cost per Card	Ln 1 / Ln 2			
4	Optical Cross Connect Card Cost	Note 1			
5	Subtotal Chassis and Card Cost	Ln 3 + Ln 4			
<u>Relay Rack</u>					
6	Total Relay Rack Cost	Relay Rack 2-CS			
7	Number of Chassis per Rack	Note 2			
8	Number of Cards per Chassis	Note 1			
9	Subtotal Relay Rack Cost per Card	Ln 6 / Ln 7 / Ln 8			
10	Total Material	Ln 5 + Ln 9			
11	Number of Connectors per Card	Note 1			
12	Material Cost per Connector	Ln 10 / Ln 11			\$ 10.85
<u>Floor Space</u>					
13	Floor Space Cost per Relay Rack				
14	Floor Space Cost per Relay Rack	Floor Space 1-CS			
15	Number of Chassis per Rack	Note 2			
16	Number of Cards per Chassis	Note 1			
17	Subtotal Floor Space Cost per Relay Rack per Card	Ln 14 / Ln 15 / Ln 16			
18	Number of Connectors per Card	Note 1			
19	Floor Space Cost per Connector	Ln 17 / Ln 18			\$ 0.06

Note:

Highlighted information is redacted for reasons #1 and #3. Parties may obtain this information by signing a non-disclosure agreement.

Verizon: EIS Study - Florida  
 Monthly Recurring Rate Development  
 Cable Duct Space - Fiber Optic Patchcord

Fixed Allocator: 14.09%

Ln	Cost Elements	Increment	Source	Cost (a)	Units (b)	Subtotal (c) = (a)*(b)
1	Cable Duct Space - Fiber Optic Patchcord	per fiber strand	Duct Space - Fiber Optic 1-CS	\$ 0.0006	185	\$ 0.12
2	<b>Total Incremental Monthly Cost</b>		Ln 1			<u>\$ 0.12</u>
3	<b>Contribution Amount</b>		Ln 2 * Fixed Allocator			<u>\$ 0.02</u>
4	<b>Rate Element</b>		Ln 2 + Ln 3			<u><u>\$ 0.14</u></u>

Note:

- 1) Fixed Allocator is a method used by Verizon to recover common costs.
- 2) The length for Fiber Optic Patchcord was derived from the average number of feet ordered through all central offices for a two year period.

Verizon: EIS Study - Florida  
 Monthly Recurring Cost Development  
 Cable Duct Space - Fiber Optic Patchcord

Ln	Description	Source	Cost
1	Equipment Investment	Duct Space - Fiber Optic 2-CS	
2	Installation Factor	EF&I-CS	
3	Installation Amount	Ln 1 * Ln 2	
4	Total Investment	Ln 1 + Ln 3	_____
5	Number of 2mm Patch Cords in 2" Duct System		_____
6	Fiber Guide Duct System Cost per ft. per Fiber Optic Patchcord	Ln 4 / Ln 5	
7	Annual Cost Factor	ACFs-CS	
8	Total Annual Costs	Ln 6 * Ln 7	_____
9	Monthly Cost per ft. per Fiber Optic Patchcord	Ln 8 / 12	\$ 0.0006

**Highlighted information is redacted for reasons #1 and #3. Parties may obtain this information by signing a non-disclosure agreement.**

Verizon: EIS Study - Florida  
 Monthly Recurring Cost Development  
 Cable Duct Space - Fiber Optic Patchcord

Ln	Description	Source	Loaded Labor Rate	Hours	Calculation
	<u>Material</u>				
	Fiber Guide Duct System				
1	Seventeen (17), Horizontal Straight Sections w/ Cover - 2" x 6'	Duct Space - Fiber Optic 3-CS			
2	Two (2), 45-degree down elbows - 2"	Duct Space - Fiber Optic 3-CS			
3	Sixteen (16), Junction Kit - 2"	Duct Space - Fiber Optic 3-CS			
4	Subtotal Fiber Guide Duct System	Ln 1 + Ln 2 + Ln 3			
5	Number of Feet in Fiber Duct System	Note 1			
6	Fiber Guide Duct System Cost per Foot	Ln 4 / Ln 5		\$	5.02

Note:

**Highlighted information is redacted for reasons #1 and #3. Parties may obtain this information by signing a non-disclosure agreement.**

Verizon: EIS Study - Florida  
Monthly Recurring Cost Development  
Cable Duct Space - Fiber Optic Patchcord

Docket No. 981834-TP/990321-TP  
Direct Testimony of Barbara K. Ellis  
Exhibit BKE-1  
FPSC Exhibit \_\_\_\_\_  
Page 217 of 235

<u>Item #</u>	<u>Description</u>	<u>Cost</u>	<u>Quantity</u>	<u>Extension</u>
---------------	--------------------	-------------	-----------------	------------------

**Highlighted information is redacted for reasons #1 and #3. Parties may obtain this information by signing a non-disclosure agreement.**



Verizon: EIS Study - Florida  
 Monthly Recurring Rate Development  
 Virtual Equipment Maintenance

Fixed Allocator (FA): 14.09%

Ln	Cost Elements	Increment	Source	Cost (a)	Units (b)	Subtotal (c) = (a)*(b)
1	Virtual Equipment Maintenance	per base unit	Virtual Equip Maint Blended-CS	\$ 58.62	1	\$ 58.62
2	Virtual Frame Space	per quarter rack	Virtual Frame Space 1-CS	\$ 9.07	1	\$ 9.07
3	<b>Total Incremental Monthly Cost</b>		Ln 1 + Ln 2			\$ 67.69
4	<b>Contribution Amount</b>		Ln 3 * Fixed Allocator			\$ 9.54
5	<b>Rate Element</b>		Ln 4 + Ln 3			\$ 77.23

Note:  
 Fixed Allocator is a method used by Verizon to recover common costs.

Verizon: EIS Study - Florida  
 Monthly Recurring Cost Development  
 Virtual Equipment Maintenance

Ln	Description	Source	Maintenance Costs per Base Unit A	Average # of Base Units per Rack B = Note 1	Cost per Rack C=A*B	Frequency of Maintenance D=Note 2	Weighted Cost of Maintenance per Rack E=C*D
Circuit Equipment							
1	ATM	Virtual Equip Maint 1-CS					
2	DSLAM	Virtual Equip Maint 1-CS					
3	Frame Relay	Virtual Equip Maint 1-CS					
4	Routers	Virtual Equip Maint 1-CS					
5	SMDS	Virtual Equip Maint 1-CS					
6	OC3	Virtual Equip Maint 1-CS					
7	OC12	Virtual Equip Maint 1-CS					
8	OC24	Virtual Equip Maint 1-CS					
9	OC48	Virtual Equip Maint 1-CS					
10	NGDLC	Virtual Equip Maint 1-CS					
11	Maintenance Cost per Equipment	Sum(Ln 1..Ln 10)				1.000	
12	Maint Cost for Equip per Quarter Rack	Ln 11 / 4					\$ 58.62

Note:

Highlighted information is redacted for reasons #1 and #3. Parties may obtain this information by signing a non-disclosure agreement.

**Verizon: EIS Study - Florida**  
**Monthly Recurring Cost Development**  
**Virtual Equipment Maintenance**

Ln	Description	Source	Loaded Labor Rate A	Trouble and Routine Maintenance		
				Labor Hours B	Annual Calculation C=A*B	Monthly Calculation D=C/12
Circuit Equipment						
1	ATM	Virtual Equip Maint 2-CS				
2	DSLAM	Virtual Equip Maint 2-CS				
3	Frame Relay	Virtual Equip Maint 2-CS				
4	Routers	Virtual Equip Maint 2-CS				
5	SMDS	Virtual Equip Maint 2-CS				
6	OC3	Virtual Equip Maint 2-CS				
7	OC12	Virtual Equip Maint 2-CS				
8	OC24	Virtual Equip Maint 2-CS				
9	OC48	Virtual Equip Maint 2-CS				
10	NGDLC	Virtual Equip Maint 2-CS				

Note:

**Highlighted information is redacted for reasons #2 and #3. Parties may obtain this information by signing a non-disclosure agreement.**

Ln	Description	Source	Type of Advanced Data Services Equipment						
			ATM	DSLAM	Frame Relay	Routers	SMDS	OC3 / OC48	NGDLC
<u>Trouble Maintenance</u>									
1	Circuit Equipment Labor (per trouble ticket)								
2	Circuit Equipment - Troubleshooting	Note 1							
3	Circuit Equipment - Restoration	Note 1							
4	Total Trouble Maintenance per Trouble Ticket	Ln 1 + Ln 2							
5	Average Trouble Tickets per Base Unit per Year	Note 2							
6	Trouble Maintenance Labor per Year	Ln 4 * Ln 5							
<u>Routine Maintenance</u>									
7	Routine Maint Labor per Base Unit per Year	Note 1							
8	Total Trouble and Routine Maintenance per Base Unit per Year	Ln 6 + Ln 7							

Note:

**Highlighted information is redacted for reasons #3 and #4. Parties may obtain this information by signing a non-disclosure agreement.**

Verizon: EIS Study - Florida  
 Monthly Recurring Cost Development  
 Virtual Frame Space

Ln	Description	Source	Calculation
<b><u>Per Quarter Rack</u></b>			
1	Equipment Investment (per quarter rack)	Virtual Frame Space 2-CS	
2	Installation Cost (per quarter rack)	Virtual Frame Space 2-CS	
3	Total Investment (per quarter rack)	Ln 1 + Ln 2	
4	Annual Cost Factor	ACFs-CS	
5	Total Frame Cost (per quarter rack)	Ln 3 * Ln 4	
6	Floor Space Cost (per quarter rack)	Virtual Frame Space 2-CS	
7	Monthly Cost (per quarter rack)	Ln 5 / 12 + Ln 6	\$ 9.07
<b><u>Per Shelf</u></b>			
8	Equipment Investment (per shelf)	Virtual Frame Space 2-CS	
9	Installation Cost (per shelf)	EF&I-CS	
10	Total Investment (per shelf)	Ln 8 + Ln 9	
11	Annual Cost Factor	ACFs-CS	
12	Total Frame Cost (per shelf)	Ln 10 * Ln 11	
13	Floor Space Cost (per shelf)	Virtual Frame Space 2-CS	
14	Monthly Cost (per shelf)	Ln 12 / 12 + Ln 13	\$ 2.27

Highlighted information is redacted for reasons #1 and #3. Parties may obtain this information by signing a non-disclosure agreement.

Verizon: EIS Study - Florida  
 Monthly Recurring Cost Development  
 Virtual Frame Space

Ln	Description	Source	Calculation
1	Frame/Relay Rack	Relay Rack-CS	
2	Floor Space Cost per Frame	Floor Space 1-CS	
	Installation and Grounding of Relay Rack		
3	Installation Factor	EF&I-CS	
4	Installation Cost	Ln 1 * Ln 3	_____
5	Number of quarter racks per Relay Rack		
6	Number of shelves per Relay Rack		
7	Material Cost per quarter rack	Ln 1 / Ln 5	
8	Installation Cost per quarter rack	Ln 4 / Ln 5	
9	Floor Space Cost per Frame per quarter rack	Ln 2 / Ln 5	
10	Material Cost per shelf	Ln 1 / Ln 6	
11	Installation Cost per shelf	Ln 4 / Ln 6	
12	Floor Space Cost per Frame per shelf	Ln 2 / Ln 6	

Note:

**Highlighted information is redacted for reasons #1 and #3. Parties may obtain this information by signing a non-disclosure agreement.**

Verizon: EIS Study - Florida  
 Monthly Recurring Rate Development  
 Adjacent On-Site - Subduct Space

Fixed Allocator (FA): 14.09%

Ln	Cost Elements	Increment	Source	Incremental Cost	Contribution Amount	Rate Element
				(a)	(b) = (a) * FA	(c) = (a)+(b)
1	Adjacent Subduct Space - Manhole	per subduct	Cable Space 1-CS	\$ 6.76	\$ 0.95	\$ 7.71
2	Adjacent Subduct Space	per linear foot	Cable Space 1-CS	\$ 0.04	\$ 0.01	\$ 0.05

Note:  
 Fixed Allocator is a method used by Verizon to recover common costs.

Verizon: EIS Study - Florida  
 Monthly Recurring Rate Development  
 Adjacent On-Site - Conduit Space

Fixed Allocator (FA): 14.09%

Ln	Cost Elements	Increment	Source	Incremental Cost (a)	Contribution Amount (b) = (a) * FA	Rate Element (c) = (a)+(b)
1	Adjacent Conduit Space - (4" Duct) Metallic - Manhole	per conduit	Cable Space 1-CS	\$ 12.83	\$ 1.81	\$ 14.64
2	Adjacent Conduit Space - (4" Duct) Metallic Cable	per linear foot	Cable Space 1-CS	\$ 0.06	\$ 0.01	\$ 0.07

Note:  
 Fixed Allocator is a method used by Verizon to recover common costs.



Verizon: EIS Study - Florida  
 Monthly Recurring Rate Development  
 Adjacent On-Site - Facility Termination

Fixed Allocator (FA): 14.09%

Ln	Cost Elements	Increment	Source	Incremental Cost	Contribution Amount	Rate Element
				(a)	(b) = (a) * FA	(c) = (a)+(b)
1	Adjacent Facility Termination DSO Cable - Material	per 100 pr	Facility Term 1-CS	\$ 2.81	\$ 0.40	\$ 3.21
2	Adjacent Facility Termination DS1 Cable - Material	per 28 pr	Facility Term 3-CS	\$ 9.18	\$ 1.29	\$ 10.47
3	Adjacent Facility Termination DS3 Cable - Material	per coaxial cable	Facility Term 5-CS	\$ 22.01	\$ 3.10	\$ 25.11

Note:

Fixed Allocator is a method used by Verizon to recover common costs.

Verizon: EIS Study - Florida  
 Monthly Recurring Rate Development  
 Adjacent On-Site - Cable Vault Splice

Fixed Allocator (FA): 14.09%

Ln	Cost Elements	Increment	Source	Incremental	Contribution	Rate Element
				Cost	Amount	
				(a)	(b) = (a) * FA	(c) = (a)+(b)
1	Adjacent Cable Vault Splice (per 1200 pr) Material	per splice closure	Cable Vault Splice 1-CS	\$ 519.83	\$ 73.26	\$ 593.08
2	Adjacent Cable Vault Splice (per 900 pr) Material	per splice closure	Cable Vault Splice 1-CS	\$ 378.87	\$ 53.39	\$ 432.26
3	Adjacent Cable Vault Splice (per 600 pr) Material	per splice closure	Cable Vault Splice 2-CS	\$ 251.95	\$ 35.51	\$ 287.46
4	Adjacent Cable Vault Splice (per 100 pr) Material	per splice closure	Cable Vault Splice 2-CS	\$ 53.25	\$ 7.50	\$ 60.76
5	Adjacent Cable Vault Splice (48 fiber) Material	per splice closure	Cable Vault Splice 3-CS	\$ 10.48	\$ 1.48	\$ 11.95
6	Adjacent Cable Vault Splice (96 fiber) Material	per splice closure	Cable Vault Splice 3-CS	\$ 32.39	\$ 4.56	\$ 36.96

Note:  
 Fixed Allocator is a method used by Verizon to recover common costs.

Verizon: EIS Study - Florida  
 Monthly Recurring Rate Development  
 Adjacent On-Site - Cable Rack Space

Fixed Allocator (FA): 14.09%

Ln	Cost Elements	Increment	Source	Incremental Cost (a)	Contribution Amount (b) = (a) * FA	Rate Element (c) = (a)+(b)
1	Adjacent Cable Rack Space - Metallic DSO	per linear foot	Cable Rack Space 1-CS	\$ 0.0035	\$ 0.0005	\$ 0.0040
2	Adjacent Cable Rack Space - Metallic DS1	per linear foot	Cable Rack Space 1-CS	\$ 0.0022	\$ 0.0003	\$ 0.0025
3	Adjacent Cable Rack Space - Fiber	per innerduct foot	Cable Rack Space 1-CS	\$ 0.0049	\$ 0.0007	\$ 0.0056
4	Adjacent Cable Rack Space - Coaxial	per linear foot	Cable Rack Space 1-CS	\$ 0.0007	\$ 0.0001	\$ 0.0100

Note:  
 Fixed Allocator is a method used by Verizon to recover common costs.

Verizon Expanded Interconnection Services  
**Common Tables**

Florida

Section 3

Table of Contents

	Page
COEI Time Study	229
Material Loadings	230
Annual Cost Factors	231
Single Source Provider Rates	232
Loaded Labor Rates	233
Engineered Furnished and Installed Factors	235

Description	HPU	Labor Group
TERMINATE SWB CABLE (.025 PER END)		
RUN & SECURE SWB/SHIELD/COAX CA/INNERDUCT (.025/FT)		
TERMINATE SHIELD/COAX CA. (.25 PER END)		
RUN & SECURE PWR CA 250 TO 1000 (.25 PER FT)		
TERM PWR CA 250 TO 1000 (.75 HRS PER TAP)		
ERECT RELAY RACK (3 HRS/RACK)		
ERECT SUPER STRUCTURE (.3 HRS/FT.)		
TRAVEL TIME - INSTALLATION		

**Highlighted information is redacted for reason #3. Parties may obtain this information by signing a non-disclosure agreement.**

**MATERIAL LOADING FACTORS**

State		Description	Supply	Minormat	Matload
FL1G	CKT	Circuit			
FL1G	COE	Central Office Equipment			
FL1G	FIBC	Fiber Cable			
FL1G	METC	Metallic Cable			

State		Description	Freight	Sales tax	Provisioning
FL1G	CKT	Circuit			
FL1G	COE	Central Office Equipment			
FL1G	FIBC	Fiber Cable			
FL1G	METC	Metallic Cable			

**Highlighted information is redacted for reason #3. Parties may obtain this information by signing a non-disclosure agreement.**

Verizon: EIS Study - Florida  
Monthly Recurring Costs  
Annual Cost Factors (ACFs)  
Rate of Return = 18.36%

Account	Description	Capital Recovery	Composite Tax	Pool Factor	Property Tax	Total ACF
211100	Land					
212100	Buildings					
221200	Digital Electronic Switching					
223200	Circuit Equipment					
242210	Underground Cable-Metallic					
242220	Underground Cable-Fiber					
244100	Conduit Systems					

**Highlighted information is redacted for reason #3. Parties may obtain this information by signing a non-disclosure agreement.**

Verizon: EIS Study - Florida  
SSP Rate

<u>OUTSIDE PLANT ACTIVITIES</u>	<u>Average Cost per foot</u>
P43C (Place fiber in Conduit)	
P43D (Place metallic cable up to < 1.5" Dia.)	
P43E (Place metallic cable > 1.5" Dia.)	
S50A (Cable Splice - per Fiber, 48 Fiber Cable or Less)	
S50B (Cable Splice - per Fiber, Greater than 48 Fiber Cable)	
S02C (Cable Splice - Metallic > 200pr)	
S02A (Cable Splice - Metallic < 200pr)	

**Highlighted information is redacted for reasons #1, #3 and #4. Parties may obtain this information by signing a non-disclosure agreement.**



Verizon: EIS Study - Florida  
Loaded Labor Rates

	DIRECT BASIC	OVERTIME PREMIUM	PAID ABSENT	DIRECT DEPT	DIRECT SUP/SUPV	INDIRECT SUP/SUPV	INDIRECT DEPT	MOTOR VEHICLE	TOOLS	BENEFITS	LOADED RATE
SAP COST POOL	10	10	10	10	20	30	30	40	50	90	
DOC TYPE	OA	OB	OB	OB	OC	OD	OD	OF	OG	OE	

LABOR GROUP

011 - EQUIP ENGR

011 - LAND & BUILDING ENGR

021 - OUTSIDE PLANT ENGR

031 - SALES ENGR

101 - EQUIP INSTALL

111 - CONSTR PLACER

121 - CONSTR SPLICER

201 - I&R/MAINT SPLICER

211 - SWITCHING SVC

221 - PBX INSTAL & MAINT

231 - COIN COLL/MAINT

Highlighted information is redacted for reason #2. Parties may obtain this information by signing a non-disclosure agreement.

STATE	JOBTITLE	BASERATE	OT & PD Absence	Indirect Rate	Direct Support	VIP	Labor Rate	BENEFITS	LOADED RATE
FL	Clerk								
FL	5								

**Highlighted information is redacted for reason #2. Parties may obtain this information by signing a non-disclosure agreement.**

Verizon: EIS Study - Florida  
Engineered Furnished and Installed Factor

Description	Account #	Factors
Digital Circuit Installation	2232	
Power Installation	2212	

**Highlighted information is redacted for reasons #3 and #4. Parties may obtain this information by signing a non-disclosure agreement.**



**Service Costs**

# **Florida**



## **Dedicated Transit Service**

**Filed - 02-04-2003**

PUBLIC VERSION



**Wholesale Non-recurring Study**

**Florida  
Dedicated Transit Service  
Table of Contents**

	Tab	Page
Summary of Rate Elements -----	1	1-4
Ordering		
Summary of Costs -----	2	2-1
Provisioning		
Summary of Costs -----	3	3-1
Field Work		
Summary of Costs -----	4	4-1
Loaded Labor Rates -----	5	5-1



Wholesale Non-recurring Study  
**Florida**  
**Dedicated Transit Service**  
**Table of Exhibits - Summary by Page**

	Exhibit Name	Page
Summary Narrative _____		1-1
Dedicated Transit Service _____	RNWE	1-4
Dedicated Transit Service _____	RDTS	1-5
Ordering Factors _____	RORF	1-6



**Wholesale Non-recurring Study**  
**Florida**  
**Dedicated Transit Service**  
**Table of Exhibits - Summary by Exhibit**

	Exhibit Name	Page
Summary Narrative _____		1-1
Dedicated Transit Service _____	RDTs	1-5
Dedicated Transit Service _____	RNWE	1-4
Ordering Factors _____	RORF	1-6

# Verizon - Florida

## Dedicated Transit Service Wholesale Non-Recurring Study

---

Docket No. 981834-TP/990321-TP  
Direct Testimony of Barbara K. Ellis  
Exhibit BKE-2  
FPSC Exhibit \_\_\_\_\_  
Page 4 of 67

### Introduction

This study accounts for the activities associated with installation and removal of Dedicated Transit Service. Dedicated Transit Service (DTS) allows a collocator to interconnect its network and collocated equipment with that of another collocator within the same Central Office. DTS is provided between the collocated arrangements of the same collocated customer or of two different collocated customers. DTS is available at the DS0, DS1, and DS3 electrical transmission level or using dark fiber.

DTS is ordered through an Access Service Request (ASR) and provisioned through the same processes as the Wholesale UNE products.

This cost study is a Verizon work product.

### Dedicated Transit Service UNE NRC Study Organization

The Dedicated Transit Service UNE NRC study is organized into the following sections:

- Work Group Costs
- Data Inputs

### Cost Study Methodology

The Ordering and Service Connections were developed from work sampling studies, time-and-motion studies, and estimates from Subject Matter Experts (SMEs). The most current Loaded Labor Rates for each of the workgroups was used.

The NRC rates reflect the cost of the set of activities required to install and disconnect Dedicated Transit Service. The charge is non-recurring in that the constituent costs are encountered only once, at the time a service is activated or discontinued in response to a CLEC request.



# Verizon - Florida

## Dedicated Transit Service Wholesale Non-Recurring Study

---

Docket No. 981834-TP/990321-TP  
Direct Testimony of Barbara K. Ellis  
Exhibit BKE-2  
FPSC Exhibit \_\_\_\_\_  
Page 5 of 67

### Cost Development

Dedicated Transit NRCs were developed using the following methods of data collection:

- ◆ Time and motion studies for the National Accounts Customer Center (NACC).
- ◆ SME inputs and database reports for the provisioning activities.
- ◆ Time and motion studies for Central Office Installation activities.

The SMEs and cost team collected activity times and determined task probabilities. Using the most current Loaded Labor Rates, the cost team then calculated the costs using the standard non-recurring cost calculation:

$$\text{Activity Time} \times \text{Probability} \times \text{Labor Rate} = \text{Cost}$$

### Cost Methodology - Dedicated Transit Service

#### *Order Entry*

The National Access Customer Center processes all ASRs for the Network Wholesale UNEs.

NACC - The CLEC sends an ASR to Verizon's NACC Service Representative using the EXACT system, fax or mail. The cost team conducted a time and motion study of the activities required to process ASRs.

The cost team calculated the ordering costs for Dedicated Transit Service on a per order basis.

**Verizon - Florida**  
**Dedicated Transit Service Wholesale Non-Recurring Study**

---

Docket No. 981834-TP/990321-TP  
Direct Testimony of Barbara K. Ellis  
Exhibit BKE-2  
FPSC Exhibit \_\_\_\_\_  
Page 6 of 67

***Provisioning***

Two work centers are involved in the provisioning process for Dedicated Transit Service orders:

APC/RCMAC - The APC/RCMAC has the responsibility for assignment of central office line equipment and outside plant facilities. SMEs provided the work times.

BRPC - Cost managers used data from the TBS database to determine the number and type of orders or lines, as appropriate, worked by each of the following BRPC groups: SOE, Design and Admin. Only those orders handled by a workgroup during provisioning are included in determining that group's cost per order.

The cost per order for each workgroup is developed separately, based on the number of orders worked by that group, and the group's productive hours spent on those orders.

***Field Work***

Field Work involves all activities directly related to outside plant connectivity performed in the central office for Dedicated Transit Service.

CO Work - activities involve running jumpers for inter-office access. Jumper studies were used to develop the costs for this workgroup.

**Verizon - Florida**  
**Wholesale Non-recurring Study**  
**Rate Summary**  
**Dedicated Transit Service**

Description	Ordering		Service Connection	
	100% Manual	Semi- Mech.	Provisioning	CO Wiring
<b>Dedicated Transit Service</b>				
Dedicated Transit Service DS0 - Initial	\$74.99	\$42.46	\$133.60	\$18.24
Dedicated Transit Service DS0 - Disconnect	\$67.58	\$38.01	\$46.67	\$2.94
Dedicated Transit Service DS1 - Initial	\$74.99	\$42.46	\$132.73	\$19.29
Dedicated Transit Service DS1 - Disconnect	\$69.87	\$40.30	\$46.67	\$2.94
Dedicated Transit Service DS3 - Initial	\$74.99	\$42.46	\$132.73	\$65.59
Dedicated Transit Service DS3 - Disconnect	\$69.87	\$40.30	\$46.67	\$2.94
Dedicated Transit Service Dark Fiber - Initial	\$74.43	\$71.47	\$36.20	\$60.29
Dedicated Transit Service Dark Fiber - Disconnect	\$39.53	\$39.53	\$36.20	\$2.94

**Verizon - Florida**  
**Wholesale Non-recurring Study**  
**Rate Development**  
**Dedicated Transit Service**

Ln	Description	Source	Ordering		Service Connection - Per Order			Destination
			100% Manual	Semi- Mech.	Provisioning	CO Work	Field Installation	
			A=Source	B=Source	C=PRO	D=FWS	E	
<b>Dedicated Transit Service</b>								
<b>DS0</b>								
1	Disconnect	ORS	\$67.58	\$38.01	\$46.67	\$2.94	n/a	RNWE
<b>Subsequent</b>								
2	Change	ORS	\$68.21	\$38.64	\$133.60	\$18.24	n/a	
3	Record Order	RORF	\$6.78	\$3.82	n/a	n/a	n/a	
4	Total	Ln 2+Ln 3	\$74.99	\$42.46	\$133.60	\$18.24	n/a	RNWE
<b>DS1</b>								
5	Disconnect	ORS	\$69.87	\$40.30	\$46.67	\$2.94	n/a	RNWE
<b>Subsequent</b>								
6	Change	ORS	\$68.21	\$38.64	\$132.73	\$19.29	n/a	
7	Record Order	RORF	\$6.78	\$3.82	n/a	n/a	n/a	
8	Total	Ln 6+Ln 7	\$74.99	\$42.46	\$132.73	\$19.29	n/a	RNWE
<b>DS3</b>								
9	Disconnect	ORS	\$69.87	\$40.30	\$46.67	\$2.94	n/a	RNWE
<b>Subsequent</b>								
10	Change	ORS	\$68.21	\$38.64	\$132.73	\$65.59	n/a	
11	Record Order	RORF	\$6.78	\$3.82	n/a	n/a	n/a	
12	Total	Ln 10+Ln 11	\$74.99	\$42.46	\$132.73	\$65.59	n/a	RNWE
<b>Dark Fiber</b>								
13	Disconnect	ORS	\$39.53	\$39.53	\$36.20	\$2.94	n/a	RNWE
<b>Initial</b>								
14	New	ORS	\$67.65	\$67.65	\$36.20	\$60.29	n/a	
15	Record Order	RORF	\$6.78	\$3.82	n/a	n/a	n/a	
16	Total	Ln 14+Ln 15	\$74.43	\$71.47	\$36.20	\$60.29	n/a	RNWE

**Verizon - Florida**  
**Wholesale Non-recurring Study**  
**Rate Development**  
**Ordering Factors**

Ln	Description	Source	Ordering Cost		Weighting Factor		Destination
			100% Manual	Semi-Mech.	100% Manual	Semi-Mech.	
			A=Source	B=Source	C=Source	D=Source	
	<b>Order Weighting</b>						
	<b>Network Wholesale Elements</b>						
1	Record Order	ORS	\$67.80	\$38.23			
2	Occurrence Rate	Note 1			10%	10%	
3	<b>Weighted Record Order</b>	Ln 1*Ln 2	<b>\$6.78</b>	<b>\$3.82</b>			RDTS

Note 1: Weighting Factors provided by Product Management.



**Wholesale Non-recurring Study**  
**Florida**  
**Dedicated Transit Service**  
**Table of Exhibits - Ordering by Page**

	Exhibit	Page
	Name	
Summary of Costs -----	ORS	2-1
Cost Calculations -----	ORD	2-2
Appendix Summary -----	AOIS	2-4
Weighted Loaded Labor Rates Calculation -----	AOLR	2-6
Dark Fiber Order Processing - Minutes per Order -----	ADFO	2-7
Network Wholesale Elements Minute per Order Calculations - DTS -----	AIDC	2-8
Network Wholesale Elements - Record Order Minutes per Order -----	AARD	2-10
Network Wholesale Elements - Order Entry Time per Order - Trunk Ports (SS7) -----	AAEP	2-11
Network Wholesale Elements - Order Entry Time per Order - DTS -----	AAEE	2-12
Network Wholesale Elements - Quality Check Time per Order - Trunk Ports -----	AAQP	2-13
Network Wholesale Elements - Quality Check Time per Order - DTS -----	AAQE	2-14
Network Wholesale Elements - Order Entry Time Study Results -----	AATT	2-15
Network Wholesale Elements - Quality Check Time Study Results -----	AATQ	2-17
Network Wholesale Elements - Project Minutes per Order -----	AAPO	2-18
Network Wholesale Elements - MOG Minutes per Order -----	AAMO	2-19
Network Wholesale Elements - Escalation and Unguided Usage Minutes per Order -----	AAEU	2-20
Network Wholesale Elements - Additional Time per Manual Order -----	AAME	2-21
Network Wholesale Elements - Relationship of Trunk Only to Facilities and Trunk -----	AATF	2-22
Network Wholesale Elements - Trunk Port Orders -----	AAPV	2-23
Network Wholesale Elements - Entrance Facilities Orders -----	AAEF	2-25



**Wholesale Non-recurring Study**  
**Florida**  
**Dedicated Transit Service**  
**Table of Exhibits - Ordering by Exhibit**

	Exhibit	Page
	Name	
Network Wholesale Elements - Order Entry Time per Order - DTS -----	AAEE	2-12
Network Wholesale Elements - Entrance Facilities Orders -----	AAEF	2-25
Network Wholesale Elements - Order Entry Time per Order - Trunk Ports (SS7) -----	AAEP	2-11
Network Wholesale Elements - Escalation and Unguided Usage Minutes per Order -----	AAEU	2-20
Network Wholesale Elements - Additional Time per Manual Order -----	AAME	2-21
Network Wholesale Elements - MOG Minutes per Order -----	AAMO	2-19
Network Wholesale Elements - Project Minutes per Order -----	AAPO	2-18
Network Wholesale Elements - Trunk Port Orders -----	AAPV	2-23
Network Wholesale Elements - Quality Check Time per Order - DTS -----	AAQE	2-14
Network Wholesale Elements - Quality Check Time per Order - Trunk Ports -----	AAQP	2-13
Network Wholesale Elements - Record Order Minutes per Order -----	AARD	2-10
Network Wholesale Elements - Relationship of Trunk Only to Facilities and Trunk -----	AATF	2-22
Network Wholesale Elements - Quality Check Time Study Results -----	AATQ	2-17
Network Wholesale Elements - Order Entry Time Study Results -----	AATT	2-15
Dark Fiber Order Processing - Minutes per Order -----	ADFO	2-7
Network Wholesale Elements Minute per Order Calculations - DTS -----	AIDC	2-8
Appendix Summary -----	AOIS	2-4
Weighted Loaded Labor Rates Calculation -----	AOLR	2-6
Cost Calculations -----	ORD	2-2
Summary of Costs -----	ORS	2-1

**Verizon - Florida**  
**Wholesale Non-recurring Study**  
**Ordering**  
**Summary of Costs**

Description	Source	Manual Order	Semi-Mechanized Order	Destination
		A=Source	B=Source	
<b>Unbundled Network Elements (UNEs)</b>				
<b>Dedicated Transit Service</b>				
<b>DS0</b>				
Disconnect	ORD-1			RDTS
Change	ORD-1			RDTS
<b>DS1/DS3</b>				
Disconnect	ORD-2			RDTS
Change	ORD-2			RDTS
<b>Dark Fiber</b>				
New	ORD-2			RDTS
Disconnect	ORD-2			RDTS
<b>Record Order</b>	ORD-2			RORF

Highlighted information is redacted for reason #3. Parties may obtain this information by signing a non-disclosure agreement.



**Verizon - Florida**  
**Wholesale Non-recurring Study**  
**Ordering**  
**Cost Calculations**

Ln	Description	Source	Manual Order		Semi-Mechanized Order		Destination
			LLR per Minute	Minutes per Order	Cost per Order	Minutes per Order	
			A=Source	B=Source	C=A*B	D=Source	E=A*D
<b>Unbundled Network Elements (UNEs)</b>							
<b>Dedicated Transit Service</b>							
<b>DS0</b>							
Disconnect							
1	Manual Order Receipt	AOIS-1					
2	Production Order Entry	AOIS-1					
3	Error Correction	AOIS-1					
4	Jeopardies	AOIS-1					
5	Projects	AOIS-1					
6	MOG Order Entry	AOIS-1					
7	Quality Check	AOIS-1					
8	Total	Sum Lns (1..7)					ORS
<b>DS0</b>							
Change							
9	Manual Order Receipt	AOIS-1					
10	Production Order Entry	AOIS-1					
11	Error Correction	AOIS-1					
12	Jeopardies	AOIS-1					
13	Projects	AOIS-1					
14	MOG Order Entry	AOIS-1					
15	Escalations	AOIS-1					
16	Quality Check	AOIS-1					
17	Total	Sum Lns (9..16)					ORS

**Verizon - Florida**  
**Wholesale Non-recurring Study**  
**Ordering**  
**Cost Calculations**

Ln	Description	Source	LLR per Minute	Manual Order		Semi-Mechanized Order		Destination
				Minutes per Order	Cost per Order	Minutes per Order	Cost per Order	
			A=Source	B=Source	C=A*B	D=Source	E=A*D	
<b>Unbundled Network Elements (UNEs)</b>								
<b>Dedicated Transit Service</b>								
<b>DS1/DS3</b>								
Disconnect								
18	Manual Order Receipt	AOIS-1						
19	Production Order Entry	AOIS-2						
20	Error Correction	AOIS-2						
21	Jeopardies	AOIS-2						
22	Projects	AOIS-2						
23	MOG Order Entry	AOIS-2						
24	Quality Check	AOIS-2						
25	Total	Sum Lns (18..24)						ORS
<b>DS1/DS3</b>								
Change								
26	Manual Order Receipt	AOIS-1						
27	Production Order Entry	AOIS-2						
28	Error Correction	AOIS-2						
29	Jeopardies	AOIS-2						
30	Projects	AOIS-2						
31	MOG Order Entry	AOIS-2						
32	Escalations	AOIS-2						
33	Quality Check	AOIS-2						
34	Total	Sum Lns (26..33)						ORS
<b>Dark Fiber</b>								
35	New	AOIS-2						ORS
36	Disconnect	AOIS-2						ORS
<b>Record Order</b>								
37	Manual Order Receipt	AOIS-2						
38	Order Processing	AOIS-2						
39	Total	Ln 37+Ln 38						ORS

Highlighted information is redacted for reason #3. Parties may obtain this information by signing a non-disclosure agreement.

**Verizon - Florida**  
**Wholesale Non-recurring Study**  
**Ordering**  
**Appendix Summary**

Description	Source	Manual	Semi-	LLR per	Shared/Fixed	Destination
		Minutes per	Mechanized			
		Order	Order	Minute	Costs	
		A=Source	B=Source	C=AOLR		
Network Wholesale Elements Manual Order Additional Order Entry	AAME					ORD-1
Network Wholesale Elements Dedicated Transit Service DS0 Disconnect						
Production Order Entry	AIDC-1					ORD-1
Error Correction	AIDC-1					ORD-1
Jeopardies	AIDC-1					ORD-1
Projects	AIDC-1					ORD-1
MOG Order Entry	AIDC-1					ORD-1
Quality Check	AIDC-1					ORD-1
DS0 Change						
Production Order Entry	AIDC-1					ORD-1
Error Correction	AIDC-1					ORD-1
Jeopardies	AIDC-1					ORD-1
Projects	AIDC-1					ORD-1
MOG Order Entry	AIDC-1					ORD-1
Escalations	AIDC-1					ORD-1
Quality Check	AIDC-1					ORD-1

**Verizon - Florida  
 Wholesale Non-recurring Study  
 Ordering  
 Appendix Summary**

Description	Source	Manual	Semi-	LLR per	Shared/Fixed	Destination
		Minutes per Order	Mechanized Minutes per Order			
		A=Source	B=Source	C=AOLR		
<b>Network Wholesale Elements</b>						
<b>Dedicated Transit Service</b>						
<b>DS1/DS3</b>						
Disconnect						
Production Order Entry	AIDC-2					ORD-2
Error Correction	AIDC-2					ORD-2
Jeopardies	AIDC-2					ORD-2
Projects	AIDC-2					ORD-2
MOG Order Entry	AIDC-2					ORD-2
Quality Check	AIDC-2					ORD-2
<b>DS1/DS3</b>						
Change						
Production Order Entry	AIDC-2					ORD-2
Error Correction	AIDC-2					ORD-2
Jeopardies	AIDC-2					ORD-2
Projects	AIDC-2					ORD-2
MOG Order Entry	AIDC-2					ORD-2
Escalations	AIDC-2					ORD-2
Quality Check	AIDC-2					ORD-2
<b>Dark Fiber</b>						
New	ADFO					ORD-2
Disconnect	ADFO					ORD-2
<b>Record Order</b>	AIDC-2					ORD-2

Highlighted information is redacted for reason #3. Parties may obtain this information by signing a non-disclosure agreement.

**Verizon - Florida  
 Wholesale Non-recurring Study  
 Ordering  
 Weighted Loaded Labor Rates Calculation**

Ln	Description	Source	LLR per Minute	Number of Reps	Percent of Reps	Weighted LLR per Minute	Destination
			A=ALLR-1	B=Note 1	C=Source	D=A*C	
	NACC Personnel						
1	North Carolina NACC - Service Consultant	Note 1					AOIS-1, 2
2	North Carolina NACC - Coordinator	Note 1					AOIS-1, 2
3	North Carolina NACC - Senior Administrator	Note 1					AOIS-1, 2

Note 1: There is one job class performing this work, therefore weighting of the LLR per minute is unnecessary and the percent is 100%.

Highlighted information is redacted for reason #3. Parties may obtain this information by signing a non-disclosure agreement.

**Verizon - Florida**  
**Wholesale Non-recurring Study**  
**Ordering**  
**Dark Fiber Order Processing - Minutes per Order**

Description	Manual and Semi-Mechanized Minutes per Order	Destination
Dark Fiber New Disconnect	A=Note 1	AOIS-2 AOIS-2

Note 1: Data provided by NACC Staff Support personnel.

Highlighted information is redacted for reason #3. Parties may obtain this information by signing a non-disclosure agreement.

**Verizon - Florida**  
**Wholesale Non-recurring Study**  
**Ordering - NACC**  
**Network Wholesale Elements Minute per Order Calculations - DTS**

Description	Source	Minutes per Activity	Probability of Occurrence	Manual and Semi Mechanized	Destination
				Minutes per Order	
		A=Source	B=Source	C=A*B	
<b>Network Wholesale Elements</b>					
<b>Dedicated Transit Service</b>					
<b>DS0</b>					
Disconnect					
Production Order Entry	AAEE				AOIS-1
Error Correction	AAEE				AOIS-1
Jeopardies	AAEE				AOIS-1
Projects	AAPO				AOIS-1
MOG Order Entry	AAMO				AOIS-1
Quality Check	AAQE				AOIS-1
<b>Dedicated Transit Service</b>					
<b>DS0</b>					
Change					
Production Order Entry	AAEE				AOIS-1
Error Correction	AAEE				AOIS-1
Jeopardies	AAEE				AOIS-1
Projects	AAPO				AOIS-1
MOG Order Entry	AAMO				AOIS-1
Escalations	AAEU				AOIS-1
Quality Check	AAQE				AOIS-1

**Verizon - Florida**  
**Wholesale Non-recurring Study**  
**Ordering - NACC**  
**Network Wholesale Elements Minute per Order Calculations - DTS**

Description	Source	Minutes per	Probability of	Manual and	Destination
		Activity	Occurrence	Semi Mechanized Minutes per Order	
		A=Source	B=Source	C=A*B	
<b>Network Wholesale Elements</b>					
<b>Dedicated Transit Service</b>					
<b>DS1/DS3</b>					
Disconnect					
Production Order Entry	AAEE				AOIS-2
Error Correction	AAEE				AOIS-2
Jeopardies	AAEE				AOIS-2
Projects	AAPO				AOIS-2
MOG Order Entry	AAAO				AOIS-2
Quality Check	AAQE				AOIS-2
<b>DS1/DS3</b>					
Change					
Production Order Entry	AAEE				AOIS-2
Error Correction	AAEE				AOIS-2
Jeopardies	AAEE				AOIS-2
Projects	AAPO				AOIS-2
MOG Order Entry	AAAO				AOIS-2
Escalations	AAEU				AOIS-2
Quality Check	AAQE				AOIS-2
<b>Record Order</b>	AARD				AOIS-2

Highlighted information is redacted for reason #3. Parties may obtain this information by signing a non-disclosure agreement.



**Verizon - Florida**  
**Wholesale Non-recurring Study**  
**Ordering - NACC**  
**Network Wholesale Elements - Record Order Minutes per Order**

Ln	Description	Source	Minutes per Occurrence	Percent Quality Check	Minutes per Order	Total Record Orders	Percent of Record Orders	Weighted Minutes per Order	Destination
			A=Source	B=Source	C=A*B	D=AAEP, AAEE	E=D/D Ln 7	F=C*E	
	<b>Record Order Trunk Ports</b>								
1	Order Entry	AAEP							
2	Quality Check	AAQP							
3	Total Trunk Port	Ln 1 + Ln 2							
	<b>Entrance Facilities</b>								
4	Order Entry	AAEE							
5	Quality Check	AAQE							
6	Total Entrance Facilities	Ln 4 + Ln 5							
7	Total	Ln 3 + Ln 6							AIDC-2

Highlighted information is redacted for reason #3. Parties may obtain this information by signing a non-disclosure agreement.

**Verizon - Florida**  
**Wholesale Non-recurring Study**  
**Ordering - NACC**  
**Network Wholesale Elements - Order Entry Time per Order - Trunk Ports (SS7)**

Ln	Description	Time Index	Orders	Productive Minutes	Time Base Calculation	Trunk Ports Factors	Average Trunk Ports Minutes per Order	Facilities and Trunks Minutes per Order	Trunk Only Minutes per Order	Probability of Occurrence	Destination
		A=AATT-1	B=AAPV-1,2	C=Note 1	D=Note 2	E=AAQP	F=A*D	G=F*E Ln 11	H=F*E Ln 12	I=AAPV-1,2	
	<b>Trunk Ports</b>										
	Production Order Entry										
1	New Orders										
2	Disconnect Orders										
3	Change Orders										
4	Jeopardies										
5	Meetpoints										
6	Error Corrections										
7	Record Orders										AARD
8	Expedites										
9	Productive Minutes										
10	Time Base Factor										
11	Facilities and Trunk Factor										
12	Trunk Only Factor										

Note 1: Resource Management provided the productive minutes.

Note 2: The Time Base Factor is calculated using the following equation:  $Time\ Base = C Ln 9 / [(A Ln 1 * B Ln 1) + \dots + (A Ln 8 * B Ln 8)]$

Highlighted information is redacted for reason #3. Parties may obtain this information by signing a non-disclosure agreement.

**Verizon - Florida**  
**Wholesale Non-recurring Study**  
**Ordering - NACC**  
**Network Wholesale Elements - Order Entry Time per Order - DTS**

Ln	Description	Time Index	Orders	Productive Minutes	Time Base Calculation	Minutes per Order	Probability of Occurrence	Destination
		A=AATT-2	B=AAEF-1	C=Note 1	D=Note 2	E=A*D	F=AAEF-1,2	
	Basic							
1	New Orders							
2	Disconnect Orders							
3	Change Orders							
	Entrance Facilities							
	DS0							
4	New/Migration Orders							
5	Disconnect Orders							AIDC-1
	DS1/DS3							
6	New Orders							
7	Disconnect Orders							AIDC-2
8	Change Orders							AIDC-1,2
9	Jeopardies							AIDC-1,2
10	Meetpoints							
11	Error Corrections							AIDC-1,2
12	Record Orders							AARD
13	Expedites							
14	Productive Minutes							
15	Time Base Factor							

Note 1: Resource Management provided the productive minutes.

Note 2: The Time Base Factor is calculated using the following equation: Time Base = C Ln 14 / [(A Ln 1\*B Ln 1) + ... + (A Ln 13\*B Ln 13)]

Highlighted information is redacted for reason #3. Parties may obtain this information by signing a non-disclosure agreement.

**Verizon - Florida**  
**Wholesale Non-recurring Study**  
**Ordering - NACC**  
**Network Wholesale Elements - Quality Check Time per Order - Trunk Ports**

Ln	Description	Time Index	Orders	Productive Minutes	Time Base Calculation	Trunk Ports Factors	Average Trunk Ports Minutes per Order	Facilities and Trunks Minutes per Order	Trunk Only Minutes per Order	Probability of Occurrence	Destination
		A=AATQ	B=AAPV-2	C=Note 1	D=Note 2	E=AAMO	F=A*D	G=F*E Ln 7	H=F*E Ln 8	I=AAPV-2	
	<b>Trunk Ports</b>										
1	New Orders										
2	Disconnect Orders										
3	Change Orders										
4	Record Orders										AARD
5	Productive Minutes										
6	Time Base Factor										
7	Facilities and Trunk Factor										AAEP
8	Trunk Only Factor										AAEP

Note 1: Resource Management provided the productive minutes.

Note 2: The Time Base Factor is calculated using the following equation:  $Time\ Base = C\ Ln\ 5 / [(A\ Ln\ 1 * B\ Ln\ 1) + \dots + (A\ Ln\ 4 * B\ Ln\ 4)]$

Highlighted information is redacted for reason #3. Parties may obtain this information by signing a non-disclosure agreement.

**Verizon - Florida**  
**Wholesale Non-recurring Study**  
**Ordering - NACC**  
**Network Wholesale Elements - Quality Check Time per Order - DTS**

Ln	Description	Time Index	Orders	Productive Minutes	Time Base Calculation	Minutes per Order	Probability of Occurrence	Destination
		A=AATQ	B=AAEF-2	C=Note 1	D=Note 2	E=A*D	F=AAEF-2	
	<b>Entrance Facilities</b>							
1	New Orders							
2	Disconnect Orders							AIDC-1,2
3	Change Orders							AIDC-1,2
4	Record Orders							AARD
5	Productive Minutes							
6	Time Base Factor							

Note 1: Resource Management provided the productive minutes.

Note 2: The Time Base Factor is calculated using the following equation:  $\text{Time Base} = C \text{ Ln } 5 / [(A \text{ Ln } 1 * B \text{ Ln } 1) + \dots + (A \text{ Ln } 4 * B \text{ Ln } 4)]$

Highlighted information is redacted for reason #3. Parties may obtain this information by signing a non-disclosure agreement.

**Verizon - Florida**  
**Wholesale Non-recurring Study**  
**Ordering - NACC**  
**Network Wholesale Elements - Order Entry Time Study Results**

Ln	Description	Source	Time Study				Destination
			Time Study Minutes	Time Study Activities	Minutes per Order	Time Index	
			A=Note 1	B=Note 1	C=A/B	D=Source	
<b>Trunk Ports</b>							
1	New Orders	C Ln 1/MIN Lns (1.8)					AAEP
2	Disconnect Orders	C Ln 2/MIN Lns (1.8)					AAEP
3	Change Orders	C Ln 3/MIN Lns (1.8)					AAEP
4	Jeopardies	C Ln 4/MIN Lns (1.8)					AAEP
5	Meetpoints	C Ln 5/MIN Lns (1.8)					AAEP
6	Error Corrections	C Ln 6/MIN Lns (1.8)					AAEP
7	Record Orders	C Ln 7/MIN Lns (1.8)					AAEP
8	Expedites	C Ln 8/MIN Lns (1.8)					AAEP

**Verizon - Florida**  
**Wholesale Non-recurring Study**  
**Ordering - NACC**  
**Network Wholesale Elements - Order Entry Time Study Results**

Ln	Description	Source	Time Study	Time Study	Time Study	Time Index	Destination
			Minutes	Activities	Minutes per Order		
			A=Note 1	B=Note 1	C=A/B	D=Source	
	<b>Basic</b>						
9	New Orders	C Ln 9/MIN Lns (9..21)					AAEE
10	Disconnect Orders	C Ln 10/MIN Lns (9..21)					AAEE
11	Change Orders	C Ln 11/MIN Lns (9..21)					AAEE
	<b>Entrance Facilities</b>						
	<b>DS0</b>						
12	New Orders	C Ln 12/MIN Lns (9..21)					AAEE
13	Disconnect Orders	C Ln 13/MIN Lns (9..21)					AAEE
	<b>DS1/ DS3</b>						
14	New Orders	C Ln 14/MIN Lns (9..21)					AAEE
15	Disconnect Orders	C Ln 15/MIN Lns (9..21)					AAEE
16	Change Orders	C Ln 16/MIN Lns (9..21)					AAEE
17	Record Orders	C Ln 17/MIN Lns (9..21)					AAEE
18	Jeopardies	C Ln 18/MIN Lns (9..21)					AAEE
19	Expedites	C Ln 19/MIN Lns (9..21)					AAEE
20	Meetpoints	C Ln 20/MIN Lns (9..21)					AAEE
21	Error Corrections	C Ln 21/MIN Lns (9..21)					AAEE

Note 1: Data obtained through a time and motion study at the NACC.

Highlighted information is redacted for reason #3. Parties may obtain this information by signing a non-disclosure agreement.

**Verizon - Florida**  
**Wholesale Non-recurring Study**  
**Ordering - NACC**  
**Network Wholesale Elements - Quality Check Time Study Results**

Ln	Description	Source	Time Study				Destination
			Time Study Minutes	Time Study Orders	Minutes per Order	Time Index	
			A=Note 1	B=Note 1	C=A/B	D=Source	
	<b>Trunk Ports</b>						
1	New Orders	C Ln 1/MIN Lns (1..4)					AAQP
2	Disconnect Orders	C Ln 2/MIN Lns (1..4)					AAQP
3	Change Orders	C Ln 3/MIN Lns (1..4)					AAQP
4	Record Orders	C Ln 4/MIN Lns (1..4)					AAQP
	<b>Entrance Facilities</b>						
5	New Orders	C Ln 5/MIN Lns (5..8)					AAQE
6	Disconnect Orders	C Ln 6/MIN Lns (5..8)					AAQE
7	Change Orders	C Ln 7/MIN Lns (5..8)					AAQE
8	Record Orders	C Ln 8/MIN Lns (5..8)					AAQE

Note 1: Data obtained through a time and motion study at the NACC.

Highlighted information is redacted for reason #3. Parties may obtain this information by signing a non-disclosure agreement.



**Verizon - Florida**  
**Wholesale Non-recurring Study**  
**Ordering - NACC**  
**Network Wholesale Elements - Project Minutes per Order**

Ln	Description	Source	Minutes	Orders	Minutes per Order	Probability of Occurrence	Destination
			A=Note 1	B=Source	C=A/B	D=Source	
	<b>Project Orders</b>						
1	Trunk Ports	AAPV-2					
2	New Orders	AAPV-2					
3	Change Orders	AAPV-2					
4	Disconnect Orders	AAPV-2					
5	<b>Entrance Facilities</b>	AAEF-2					
6	New Orders	AAEF-2					
7	Change Orders	AAEF-2					AIDC-1,2
8	Disconnect Orders	AAEF-2					AIDC-1,2
9	Total Project	Ln 1+Ln 5					AIDC-1,2

Note 1: Resource Management provided the productive minutes.

Highlighted information is redacted for reason #3. Parties may obtain this information by signing a non-disclosure agreement.

**Verizon - Florida**  
**Wholesale Non-recurring Study**  
**Ordering - NACC**  
**Network Wholesale Elements - MOG Minutes per Order**

Ln	Description	Source	Minutes	Orders	Facilities and			Probability of Occurrence	Destination
					Minutes per Order	Trunk Ports Factors	Trunk Only Minutes per Order		
			A=Note 1	B=Source	C=A/B	D=AATF	E=C*D Ln 10	F=C*D Ln 11	G=Source
	<b>MOG Orders</b>								
1	Trunk Ports	AAPV-1							
2	New Orders	AAPV-1							
3	Change Orders	AAPV-1							
4	Disconnect Orders	AAPV-1							
5	<b>Entrance Facilities</b>	AAEF-1							
6	New Orders	AAEF-1							
7	Change Orders	AAEF-1							AIDC-1,2
8	Disconnect Orders	AAEF-1							AIDC-1,2
9	Total MOG	Ln 1 + Ln 5							AIDC-1,2
10	Facilities and Trunk Factor								AAQP
11	Trunk Only Factor								AAQP

Note 1: Resource Management provided the productive minutes.

Highlighted information is redacted for reason #3. Parties may obtain this information by signing a non-disclosure agreement.

**Verizon - Florida**  
**Wholesale Non-recurring Study**  
**Ordering - NACC**  
**Network Wholesale Elements - Escalation and Unguided Usage Minutes per Order**

Docket No. 981834-TP/990321-TP  
 Direct Testimony of Barbara K. Ellis  
 Exhibit BKE-2  
 FPSC Exhibit \_\_\_\_\_  
 Page 31 of 67

Ln	Description	Source	Minutes	Orders	Minutes per Order	Probability of Occurrence	Destination
			A=Note 1	B=Source	C=A/B	D=Source	
<b>Escalations</b>							
1	Trunk Ports	AAPV-2					
2	Entrance Facilities	AAEF-2					AIDC-1,2
3	Total	Ln 1 + Ln 2					AIDC-1,2
4	Unguided Usage	AAPV-2					

Note 1: Resource Management provided the productive minutes.

Highlighted information is redacted for reason #3. Parties may obtain this information by signing a non-disclosure agreement.

**Verizon - Florida  
 Wholesale Non-recurring Study  
 Ordering - NACC  
 Network Wholesale Elements - Additional Time per Manual Order**

Ln	Description	Source	Minutes per Order	Destination
A=Source				
<b>Additional Time per Manual Order</b>				
1	Manual Fax Load	Note 1		
2	FOC Fax	Note 1		
3	Total	Ln 1+Ln 2		AOIS-1

Note 1: Data provided by NACC personnel.

Highlighted information is redacted for reason #3. Parties may obtain this information by signing a non-disclosure agreement.

**Verizon - Florida**  
**Wholesale Non-recurring Study**  
**Ordering - NACC**  
**Network Wholesale Elements - Relationship of Trunk Only to Facilities and Trunk**

Ln	Description	Source	Coefficient	Order Percentages	Trunk Port Factors	Destination
			A=Note 1	B=Note 2	C=Source	
1	Facilities and Trunk to Trunk Only Coefficient					
2	Facilities and Trunk Percent of Orders					
3	Trunk Only Percent of Orders					
4	Facilities and Trunk Factor		$1/((1/A * B \text{ Ln } 3) + B \text{ Ln } 2)$			AAMO
5	Trunk Only Factor		$(1 - (C \text{ Ln } 4 * B \text{ Ln } 2))/B \text{ Ln } 3$			AAMO

Note 1: A Facilities and Trunk order averages 3.10 time longer to process than a Trunk Only order. The relationship between Trunk Only and Trunk and Facility Order times was developed from work times observed during a NACC time and motion study.

Note 2: Percents provided by NACC personnel.

**Highlighted information is redacted for reason #3. Parties may obtain this information by signing a non-disclosure agreement.**

**Verizon - Florida**  
**Wholesale Non-recurring Study**  
**Ordering - NACC**  
**Network Wholesale Elements - Trunk Port Orders**

Docket No. 981834-TP/990321-TP  
 Direct Testimony of Barbara K. Ellis  
 Exhibit BKE-2  
 FPSC Exhibit \_\_\_\_\_  
 Page 34 of 67

Ln	Description	Source	Total Orders	Percent	Production vs.	Destination
					MOG Percent	
			A=Note 1	B=Source	C=Source	
	Production Orders					
1	New Orders	A Ln 1/A Ln 11				AAEP
2	Change Orders	A Ln 2/A Ln 12				AAEP
3	Subtotal	Ln 1+Ln 2				
4	Disconnect Orders	A Ln 4/A Ln 13				AAEP
5	Record Orders					AAEP
6	Subtotal	Sum Lns (3..5)				
	MOG Orders					
7	New Orders	A Ln 7/A Ln 11				AAMO
8	Change Orders	A Ln 8/A Ln 12				AAMO
9	Disconnect Orders	A Ln 9/A Ln 13				AAMO
10	Total MOG	Sum Lns (7..8)				AAMO
	Total Orders					
11	New	Ln 1+Ln 7				
12	Change	Ln 2+Ln 8				
13	Disconnect	Ln 4+Ln 9				
14	Total Orders	Ln 6+Ln 10				

**Verizon - Florida**  
**Wholesale Non-recurring Study**  
**Ordering - NACC**  
**Network Wholesale Elements - Trunk Port Orders**

Ln	Description	Source	Total Orders	Percent	Production vs. MOG Percent	Destination
			A=Note 1	B=Source	C=Source	
	Quality Check					
15	New Orders	Note 1				AAQP
16	Disconnect Orders	Note 1				AAQP
17	Change Orders	Note 1				AAQP
18	Record Orders	Note 1				AAQP
19	Jeopardies	A Ln 19/A Ln 14				AAEP
20	Meet Point	Note 2				AAEP
21	Escalations	A Ln 21/A Ln 3				AAEU
22	Projects	A Ln 22/A Ln 6				AAPO
23	New Orders	B Ln 22*C Ln 1				AAPO
24	Change Orders	B Ln 22*C Ln 2				AAPO
25	Disconnect Orders	B Ln 22*C Ln 4				AAPO
26	Unguided Usage	A Ln 26/A Ln 14				AAEU
27	Errors	A Ln 27/A Ln 6				AAEP
28	Expedites					AAEP

Note 1: Data provided by NACC personnel.

Note 2: Verizon Florida does not have any meet points with other Local Exchange Carriers.

Highlighted information is redacted for reason #3. Parties may obtain this information by signing a non-disclosure agreement.

**Verizon - Florida**  
**Wholesale Non-recurring Study**  
**Ordering - NACC**  
**Network Wholesale Elements - Entrance Facilities Orders**

Docket No. 981834-TP/990321-TP  
 Direct Testimony of Barbara K. Ellis  
 Exhibit BKE-2  
 FPSC Exhibit \_\_\_\_\_  
 Page 36 of 67

Ln	Description	Source	Basic	DS-0 and Fractional T-1	DS-1 and higher	Other Activities	Total	Percent of Order	Production vs. MOG Percent	Destination
		A=Note 1	B=Note 1	C=Note 1	D=Note 1	E=Sum (A..D)	F=Source	G=Source		
<b>Production Orders</b>										
1	New Order	E Ln 1/E Ln 11								A AEE
2	Change Order	E Ln 2/E Ln 12								A AEE
3	Subtotal	Ln 1+Ln 2								
4	Disconnect Order	E Ln 4/E Ln 13								A AEE
5	Record Order									A AEE,AARD
6	Subtotal	Sum Lns (3..5)								
<b>MOG Orders</b>										
7	New Orders	E Ln 7/E Ln 11								A AMO
8	Change Orders	E Ln 8/E Ln 12								A AMO
9	Disconnect Orders	E Ln 9/E Ln 13								A AMO
10	Total MOG	Sum Lns (7..9)								A AMO
<b>Total Orders</b>										
11	New	Ln 1+Ln 7								
12	Change	Ln 2+Ln 8								
13	Disconnect	Ln 4+Ln 9								
14	Total Orders	Ln 6+Ln 10								



**Verizon - Florida**  
**Wholesale Non-recurring Study**  
**Ordering - NACC**  
**Network Wholesale Elements - Entrance Facilities Orders**

Docket No. 981834-TP/990321-TP  
 Direct Testimony of Barbara K. Ellis  
 Exhibit BKE-2  
 FPSC Exhibit \_\_\_\_\_  
 Page 37 of 67

Ln	Description	Source	Basic	DS-0 and Fractional T-1	DS-1 and higher	Other Activities	Total	Percent of Order	Production vs. MOG Percent	Destination
			A=Note 1	B=Note 1	C=Note 1	D=Note 1	E=Sum (A..D)	F=Source	G=Source	
	Quality Check									
15	New Orders	Note 1								AAQE
16	Disconnect Orders	Note 1								AAQE
17	Change Orders	Note 1								AAQE
18	Record Orders	Note 1								AAQE
19	Jeopardies	E Ln 19/E Ln 14								AAEE
20	Meet Point	Note 2								AAEE
21	Escalations	E Ln 21/E Ln 3								AAEU
22	Projects	E Ln 22/E Ln 6								AAPO
23	New Orders	F Ln 22*G Ln 1								AAPO
24	Change Orders	F Ln 22*G Ln 2								AAPO
25	Disconnect Orders	F Ln 22*G Ln 4								AAPO
26	Errors	E Ln 26/E Ln 6								AAEE
27	Expedite									AAEE

Note 1: Data provided by NACC personnel.

Note 2: Verizon Florida does not have any meet points with other Local Exchange Carriers.

Highlighted information is redacted for reason #3. Parties may obtain this information by signing a non-disclosure agreement.



**Wholesale Non-recurring Study**  
**Florida**  
**Dedicated Transit Service**  
**Table of Exhibits - Provisioning by Page**

	Exhibit	
	Name	Page
Provisioning Group Summary _____	PRO	3-1
Provisioning Calculations _____	PRC	3-2
Appendix Summary _____	APRI	3-3
Work Time Calculations _____	APMC	3-5
Weighted Loaded Labor Rate Calculation _____	APLC	3-6
APC LLR Computation _____	AFLC	3-7
Local Loop Assignment Work Times _____	ALLA	3-8
Admin and DBM-WCC Productive Minutes and LLRs _____	AEXP	3-9
Orders and Circuits - Percentages _____	APOP	3-10
Orders and Circuits - Counts _____	APOC	3-12



**Wholesale Non-recurring Study**

**Florida**  
**Dedicated Transit Service**  
**Table of Exhibits - Provisioning by Exhibit**

	Exhibit	
	Name	Page
Admin and DBM-WCC Productive Minutes and LLRs -----	AEXP	3-9
APC LLR Computation -----	AFLC	3-7
Local Loop Assignment Work Times -----	ALLA	3-8
Weighted Loaded Labor Rate Calculation -----	APLC	3-6
Work Time Calculations -----	APMC	3-5
Orders and Circuits - Counts -----	APOC	3-12
Orders and Circuits - Percentages -----	APOP	3-10
Appendix Summary -----	APRI	3-3
Provisioning Calculations -----	PRC	3-2
Provisioning Group Summary -----	PRO	3-1

**Verizon - Florida**  
**Wholesale Non-recurring Study**  
**Provisioning**  
**Provisioning Group Summary**

Description	Source	SOE	Facility Assign	Design Group	Switch Update	Testing	Admin Group	Total Cost	Destination
		A	B	C	D	E	F	G=Sum (A..F)	
<b>Network Wholesale Elements</b>									
<b>Dedicated Transit Service</b>									
<b>DS0</b>									
Disconnect	PRC								RDTS
Change	PRC								RDTS
<b>DS1/DS3</b>									
Disconnect	PRC								RDTS
Change	PRC								RDTS
<b>Dark Fiber</b>									
New	PRC								RDTS
Disconnect	PRC								RDTS

Highlighted information is redacted for reason #3. Parties may obtain this information by signing a non-disclosure agreement.

**Verizon - Florida**  
**Wholesale Non-recurring Study**  
**Provisioning**  
**Provisioning Calculations**

Description	Probability					Destination
	Minutes per Occurrence	of Occurrence	Minutes per Order	LLR per Minute	Cost per Order	
	A=APRI-2	B=APRI-2	C=A*B	D=APRI-1	E=C*D	
<b>Network Wholesale Elements</b>						
<b>Dedicated Transit Service</b>						
DS0						
Disconnect						
Service Order Entry - Non-Message						PRO
Facility Assignment - Local Loop Assignment						PRO
Admin Group - Non-Message						PRO
Change						
Service Order Entry - Non-Message						PRO
Design Group - DS0						PRO
Admin Group - Non-Message						PRO
DS1/DS3						
Disconnect						
Service Order Entry - Non-Message						PRO
Facility Assignment - Local Loop Assignment						PRO
Admin Group - Non-Message						PRO
Change						
Service Order Entry - Non-Message						PRO
Design Group - Hi-Cap						PRO
Admin Group - Non-Message						PRO
Dark Fiber						
Design Group - Hi-Cap						PRO

Highlighted information is redacted for reason #3. Parties may obtain this information by signing a non-disclosure agreement.

**Verizon - Florida  
 Wholesale Non-recurring Study  
 Provisioning  
 Appendix Summary**

Description	Source	Minutes per	Probability of	LLR per Minute	Destination
		Occurrence	Occurrence		
		A=Source	B=APOP-1, 2	C=Source	
<b>Weighted Loaded Labor Rate</b>					
BRPC					
Service Order Entry					
Non-Message	APLC				PRC
Admin					
Non-Message	AEXP				PRC
Facility Assignment					
Local Loop Assignment	AFLC				PRC
Design Group					
DSO	APLC				PRC
Hi-Cap	APLC				PRC

**Verizon - Florida**  
**Wholesale Non-recurring Study**  
**Provisioning**  
**Appendix Summary**

Description	Source	Minutes per Occurrence	Probability of Occurrence	LLR per Minute	Destination
		A=Source	B=APOP-1, 2	C=Source	
<b>Unbundled Network Elements (UNEs)</b>					
<b>Design Group</b>					
Hi-Cap					
Complex	APMC				PRC
<b>Network Wholesale Elements</b>					
<b>Service Order Entry</b>					
Non-Message	APMC				PRC
<b>Facility Assignment</b>					
Local Loop Assignment					
Dedicated Transport					
DS0					
Disconnect	ALLA				PRC
Disconnect	ALLA				PRC
<b>Design Group</b>					
Dedicated Transport					
DS0	APMC				PRC
DS1/DS3	APMC				PRC
<b>Admin</b>					
Non-Message	APMC				PRC

Highlighted information is redacted for reason #3. Parties may obtain this information by signing a non-disclosure agreement.

**Verizon - Florida  
 Wholesale Non-recurring Study  
 Provisioning  
 Work Time Calculations**

Description	Source	Productive	Orders	Minutes per	Destination
		Minutes		Occurrence	
		A=Source	B=Source	C=A/B	
<b>Unbundled Network Elements (UNEs)</b>					
<b>Design Group</b>					
Hi-Cap	APLC-APOC-1				APRI-2
<b>Network Wholesale Elements</b>					
<b>Service Order Entry</b>					
Non-Message	APLC, APOC-1				APRI-2
<b>Design Group</b>					
DSO	APLC, APOC-2				APRI-2
Hi-Cap	APLC, APOC-2				APRI-2
<b>Admin</b>					
Non-Message	AEXP, APOC-2				APRI-2

**Highlighted information is redacted for reason #3. Parties may obtain this information by signing a non-disclosure agreement.**



**Verizon - Florida  
 Wholesale Non-recurring Study  
 Provisioning  
 Weighted Loaded Labor Rate Calculation**

Ln	Description	Source	Productive		Total Productive Cost	Weighted LLR per Minute	Destination
			Minutes	LLR per Minute			
			A=Source	B=ALLR-2, Source	C=A*B	D=C/A	
<b>Service Order Entry</b>							
Non-Message							
1	Facility Clerk	Note 1					
2	Design Tech	Note 1					
3	<b>Total</b>	Ln 1+Ln 2					APMC, APRI-1
<b>Design Group</b>							
DS0							
4	Facility Clerk	Note 1					
5	Admin Support Clerk	Note 1					
6	Design Technician	Note 1					
7	Business Response Specialist	Note 1					
8	<b>Total</b>	Sum Lns (4..7)					APMC, APRI-1
<b>Hi-Cap</b>							
9	Facility Clerk	Note 1					
10	Admin Support Clerk	Note 1					
11	Design Technician	Note 1					
12	Business Response Specialist	Note 1					
13	<b>Total</b>	Sum Lns (9..12)					APMC, APRI-1

Note 1: The productive minutes were provided by the BRPC Group Supervisors.

**Highlighted information is redacted for reason #3. Parties may obtain this information by signing a non-disclosure agreement.**

**Verizon - Florida**  
**Wholesale Non-recurring Study**  
**Provisioning**  
**APC LLR Computation**

Ln	Description	Source	Productive Hours A=Note 1	Productive Minutes B=A*60	LLR per Minute C=ALLR-2	Extended Group Cost D=B*C	Weighted LLR per Minute E=D/B	Destination
	<b>Lakeland, FL</b>							
1	Select Assignment							
2	Admin Support Clerk							
3	APC Total							
	<b>Tampa, FL</b>							
4	Select Assignment							
5	SPAG							
6	OMT							
7	Admin Support Clerk							
8	APC Total							
	<b>Clearwater, FL</b>							
9	Select Assignment							
10	Pending Order Inquiry							
11	SPAG							
12	Admin Support Clerk							
13	APC Total							
	<b>Bradenton, FL</b>							
14	Select Assignment							
15	APC Total							
	APC Total							
16	Lakeland, FL	Ln 3						
17	Tampa, FL	Ln 8						
18	Clearwater, FL	Ln 13						
19	Bradenton, FL	Ln 15						
20	Total	Sum Lns (16..19)						
21	APC LLR	D20/B20						APRI-1

Note 1: APC hours provided by APC senior supervisors.

Highlighted information is redacted for reason #3. Parties may obtain this information by signing a non-disclosure agreement.

**Verizon - Florida**  
**Wholesale Non-recurring Study**  
**Provisioning**  
**Local Loop Assignment Work Times**

Ln	Description	Source	Job Title	Work Minutes	Destination
			A	B=Note 1	
	Facility Assignment				
	Local Loop Assignment				
	Advanced/Special Elements				
	Disconnect				
1	Determine disconnect request		Complex Line Assignor		
2	Recover cable pairs, note conditioning		Complex Line Assignor		
3	Total	Ln 1+Ln 2			APRI-2

Note 1: The work times listed were provided by APC and Outside Plant Engineering personnel.

Highlighted information is redacted for reason #3. Parties may obtain this information by signing a non-disclosure agreement.

**Verizon - Florida**  
**Wholesale Non-recurring Study**  
**Provisioning**  
**Admin and DBM-WCC Productive Minutes and LLRs**

Docket No. 981834-TP/990321-TP  
 Direct Testimony of Barbara K. Ellis  
 Exhibit BKE-2  
 FPSC Exhibit \_\_\_\_\_  
 Page 48 of 67

Ln	Description	Source	Minutes per Expedites	Number of Expedites	Productive Minutes	LLR per Minute	Total Productive Cost	Weighted LLR per Minute	Destination
			A=Source	B=Source	C=Source	D=ALLR-2	E=C*D	F=E/C	
	<b>Admin</b>								
	Non-Message								
1	Facility Clerk	Note 1							
2	Additional Job Title								
3	Subtotal	Ln 1+Ln 2							APRI-1
	<b>Expedites</b>								
4	Minutes per Expedite	Note 2							
5	Number of Expedites	Note 3							
6	Productive Time - Expedites	Ln 4*Ln 5							
7	Total Productive Time less Expedites	Ln 3-Ln 6							APMC

Note 1: The productive minutes were provided by the Group Supervisors.

Note 2: The work times were provided by the Group Supervisor.

Note 3: The expedites counts were extracted from the TBS system.

Highlighted information is redacted for reason #3. Parties may obtain this information by signing a non-disclosure agreement.

**Verizon - Florida**  
**Wholesale Non-recurring Study**  
**Provisioning**  
**Orders and Circuits - Percentages**

Ln	Description	Source	Circuits	Orders	Probability of Occurrence	Destination
			A=APOC-1	B=APOC-1	B=Source	
	<b>Unbundled Network Elements (UNEs) and UNE-Platforms</b>					
	<b>Design Group</b>					
	DS0					
	Complex					
1	Complex (DS0) circuits requiring Design					
2	Complex (Hi-Cap) circuits requiring Design					
3	Total	Ln 1+Ln 2				
	Hi-Cap					
4	Complex	Note 1				APRI-2
	<b>Network Wholesale Elements</b>					
	<b>Service Order Entry</b>					
	Non-message					
5	Trunk Ports and Dedicated Transport	Note 2				APRI-2

**Verizon - Florida  
 Wholesale Non-recurring Study  
 Provisioning  
 Orders and Circuits - Percentages**

Ln	Description	Source	Circuits		Orders		Probability of Occurrence	Destination
			A=APOC-1	B=APOC-1	B=APOC-1	B=Source		
<b>Unbundled Network Elements (UNEs) and UNE-Platforms</b>								
<b>Network Wholesale Elements</b>								
<b>Facility Assignment</b>								
Local Loop Assignment								
Dedicated Transport								
DS0 and Fractional T-1								
6	DS0	Ln 6/Ln 8						
7	Fractional T-1	Ln 7/Ln 8						
8	Total	Ln 6+Ln 7						APRI-2
9	DS1/DS3	Note 3						APRI-2
<b>Design Group</b>								
Dedicated Transport								
10	DS0	Note 4						APRI-2
11	DS1/DS3	Note 1						APRI-2
<b>Admin</b>								
12	Non-Message	Note 5						APRI-2

Note 1. The Hi-Cap designers work all DS1 level Dedicated Transport - IDT/CDT, DS1 and higher orders, therefore the percent is 100%.  
 Note 2. The Service Order Entry clerks work on all service orders.  
 Note 3: Local Loop Assignment work all Hi-Cap new orders, therefore the percent is 100%.  
 Note 4: The DS0 designers work all Trunk Port New, Change with Engineering Review and Dedicated Transport - IDT/CDT, DS0 and Fractional T-1 orders, therefore the percent is 100%.  
 Note 5: All Non-message service orders are completed and monitored by the Administration group.

**Highlighted information is redacted for reason #3. Parties may obtain this information by signing a non-disclosure agreement.**

**Verizon - Florida**  
**Wholesale Non-recurring Study**  
**Provisioning**  
**Orders and Circuits - Counts**

Ln	Description	Source	Circuits	Orders	Destination
			A=Note 1	B=Note 1	
	<b>Unbundled Network Elements (UNEs) and UNE-Platforms</b>				
	<b>Design Group</b>				
	DS0 and Hi-Cap Design				
	DS0 Circuits (Design Date)				
1	Basic				
2	Complex				APOP-1
3	Total				
4	Total Hi-Cap Circuits (Design Date)				APOP-1, APMC
	<b>Network Wholesale Elements</b>				
	<b>Service Order Entry Group</b>				
	Non-Message Order Entry				
	Non-Message Orders (Issue Date)				
5	Basic DS0				
6	Complex DS0				
7	Hi-Cap				
8	Total	Sum Lns (5..7)			APMC
	<b>Facility Assignment</b>				
	Dedicated Transport-IDT/CDT Orders, DS0 and Fractional T-1 (Issue Date)				
9	Telcordia Code YG (Frame Relay DS0)				APOP-2
10	Telcordia Code DK (Fractional T-1)				APOP-2
11	Total	Ln 9+Ln 10			

**Verizon - Florida**  
**Wholesale Non-recurring Study**  
**Provisioning**  
**Orders and Circuits - Counts**

Ln	Description	Source	Circuits	Orders	Destination
			A=Note 1	B=Note 1	
	<b>Network Wholesale Elements</b>				
	<b>Design Group</b>				
	DS0 and Hi-Cap Design				
	DS0 Orders (Design Date)				
12	Basic				
13	Complex				
14	Total	Ln 12+Ln 13			APMC
15	Total Hi-Cap Orders (Design Date)				APMC
	<b>Admin</b>				
	Non-Message Clerks				
	Non-Message Orders (Completion Date)				
16	Basic DS0 Orders				
17	Complex DS0 Orders				
18	Complex Hi-Cap Orders				
19	Total	Sum Lns (16..18)			APMC

Note 1: The Circuit and Order counts were extracted from TBS data.

Highlighted information is redacted for reason #3. Parties may obtain this information by signing a non-disclosure agreement.





Wholesale Non-recurring Study  
**Florida**  
Dedicated Transit Service  
Table of Exhibits - Field Work by Page

	Exhibit	
	Name	Page
Summary - CO Wiring _____	FWS	4-1
Jumper Installation _____	CJIS	4-2
Jumper Study - Summary of Jumper/Drive Time - Central Office Installation _____	AJDT	4-3
Jumper Study - Activity Summary Sheet _____	AJSS	4-5
Jumper Study - Other Jumper Activities Calculation _____	AAJT	4-6
Jumper Study - Appendix Summary _____	AJIS	4-7
Jumper Material _____	AJMS	4-8



**Wholesale Non-recurring Study**  
**Florida**  
**Dedicated Transit Service**  
**Table of Exhibits - Field Work by Exhibit**

	<b>Exhibit</b>	
	<b>Name</b>	<b>Page</b>
Jumper Study - Other Jumper Activities Calculation _____	AAJT	4-6
Jumper Study - Summary of Jumper/Drive Time - Central Office Installation _____	AJDT	4-3
Jumper Study - Appendix Summary _____	AJIS	4-7
Jumper Material _____	AJMS	4-8
Jumper Study - Activity Summary Sheet _____	AJSS	4-5
Jumper Installation _____	CJIS	4-2
Summary - CO Wiring _____	FWS	4-1

**Verizon - Florida**  
**Wholesale Non-recurring Study**  
**Field Work**  
**Summary - CO Wiring**

Description	Jumper Activity Cost	Jumper Material Cost	Total Cost	Destination
	A=CJIS	B=AJMS	C=A+B	
<b>Unbundled Network Elements (UNEs)</b>				
<b>Advanced/Special Products</b>				
Jumper Installation				
DS0				RDTS
DS1				RDTS
DS3				RDTS
Dark Fiber				RDTS
Jumper Break				
DS0/DS1/DS3/Dark Fiber				RDTS

Highlighted information is redacted for reason #3. Parties may obtain this information by signing a non-disclosure agreement.

**Verizon - Florida**  
**Wholesale Non-recurring Study**  
**Field Work**  
**Jumper Installation**

Description	Minutes	LLR per Minute	Total Cost	Destination
Network Wholesale Services Dedicated Transit Service Jumper Installation DS0/DS1/DS3/Dark Fiber  Jumper Break DS0/DS1/DS3/Dark Fiber	A=AJDT-1,2	B=ALLR-3	C=A*B	   FWS   FWS

**Verizon - Florida  
 Wholesale Non-recurring Study  
 Field Work**

**Jumper Study - Summary of Jumper/Drive Time - Central Office Installation**

Ln	Description	Source	Average Time	Central Office	Time * Wtg.	Destination
			per Line/Circuit	Weighting	Factor	
			A=Source	B=Note 2	C=A*B	
	<b>Line/Circuit - "Runs" Exchange</b>					
1	Average Drive Time per Line/Circuit	Note 1				
2	Average Host Time per Line/Circuit	AJSS				
3	Average Remote Time per Line/Circuit	Ln 1+Ln 2				
4	Average Host time per Line/Circuit	AJSS				
5	Average Time per Line/Circuit	Ln 3+Ln 4				
	<b>Advanced/Special Products</b>					
6	Average Drive Time per Line/Circuit	Note 1				
7	Average Host Time per Line/Circuit	AJSS				
8	Average Remote Time per Line/Circuit	Ln 6+Ln 7				
9	Average Host Time per Line/Circuit	AJSS				
10	Average Time per Line/Circuit	Ln 8+Ln 9				CJIS

**Verizon - Florida**  
**Wholesale Non-recurring Study**  
**Field Work**  
**Jumper Study - Summary of Jumper/Drive Time - Central Office Installation**

Ln	Description	Source	Average Time	Central Office	Time * Wtg.	Destination
			per	Weighting	Factor	
			Line/Circuit			
			A=Source	B=Note 2	C=A*B	
	<b>Jumper Breaks</b>					
	All Products					
11	Average Drive Time Line/Circuit	Note 1				
12	Average Time for Line/Circuit Break	AJSS				
13	Average Remote Time per Line/Circuit	Ln 11+Ln 12				
14	Average Host Time for Line/Circuit Break	AJSS				
15	Average Time per Line/Circuit	Ln 13+Ln 14				CJIS
	<b>Change CO Connection</b>					
	Exchange Product					
16	Average Drive Time Line/Circuit	Note 1				
17	Average Time for Line/Circuit Run & Break	Ln 2+Ln 12				
18	Average Remote Time per Line/Circuit	Ln 16+Ln 17				
19	Average Time for Line/Circuit Run & Break	Ln 2+Ln 12				
20	Average Time per Line/Circuit	Ln 18+Ln 19				

Note 1: Results taken from Drive Time Study.  
 Note 2: Weighting based on Host/Remote ratio of state-wide central offices.

**Highlighted information is redacted for reason #3. Parties may obtain this information by signing a non-disclosure agreement.**

**Verizon - Florida**  
**Wholesale Non-recurring Study**  
**Field Work**  
**Jumper Study - Activity Summary Sheet**

Description	Jumper Work	Jumper Admin	AAIS Jumper	Program	Resolve Service	Total Minutes	Destination
	A=AAJT	B=AAJT	C=AAJT	D=AAJT	E=AAJT	F=Sum (A..E)	
<b>Jumper Runs</b>							
Exchange Order Minutes per Line							
Advanced/Special Order Minutes per Line							CJIS
<b>Jumper Breaks</b>							
All Services Minutes per Line							CJIS

Highlighted information is redacted for reason #3. Parties may obtain this information by signing a non-disclosure agreement.

**Verizon - Florida**  
**Wholesale Non-recurring Study**  
**Field Work**  
**Jumper Study - Other Jumper Activities Calculation**

Ln	Description	Source	Lines	Minutes	Minutes per Line	Destination
			A=Source	B=AJIS	C=B/A	
<b>Jumper Runs</b>						
1	Exchange Orders	AJIS				AJSS
2	Advanced/Special Orders	AJIS				AJSS
<b>Jumper Breaks</b>						
3	All Services	AJIS				AJSS
<b>Other Jumper Activities</b>						
4	Jumper Admin	Sum Lns (1..3)				AJSS
5	AAIS Jumper List	Ln 1+Ln 3				AJSS
6	Programming	Ln 2				AJSS
7	Resolve Service Order	Ln 1				AJSS

Highlighted information is redacted for reason #3. Parties may obtain this information by signing a non-disclosure agreement.



**Verizon - Florida  
 Wholesale Non-recurring Study  
 Field Work  
 Jumper Study - Appendix Summary**

Description	Total Lines	Total Minutes	Destination
	A=Note 1	B=Note 1	
<b>Jumper Runs</b>			
Exchange Orders			AAJT
Advanced/Special Orders			AAJT
<b>Jumper Breaks</b>			
All Services			AAJT
<b>Other Jumper Activities</b>			
Jumper Admin			AAJT
AAIS Jumper List			AAJT
Programming			AAJT
Resolve Service Order			AAJT

Note 1: Data obtained from a Time and Motion study conducted by Arthur Anderson, LLP.

Highlighted information is redacted for reason #3. Parties may obtain this information by signing a non-disclosure agreement.

**Verizon - Florida**  
**Wholesale Non-recurring Study**  
**Field Work**  
**Jumper Material**

Description	Span Increments	Cost per Increment	Material Loading Factor	Material Loadings Cost	Extended Cost	Destination
	A=Note 1	B=Note 2	C=Note 2	D=B*C	E=B+D	
Network Wholesale Services						
Dedicated Transit Service						
Jumper Required to Span 25 Feet						
Cross Connect Jumper - DS0						RDTS
Cross Connect Jumper - DS1						RDTS
Cross Connect Jumper - DS3						RDTS
Cross Connect Jumper - Dark Fiber						RDTS

Note 1: Increments reflect standard minimum lengths necessary to span the typical jumper distance of 25 feet.  
 Note 2: Costs obtained from GTEAMS. The Material Loading includes freight, sales tax and provisioning.

Highlighted information is redacted for reason #3. Parties may obtain this information by signing a non-disclosure agreement.



**Wholesale Non-recurring Study**  
**Florida**  
**Dedicated Transit Service**  
**Table of Exhibits - Loaded Labor Rates by Page**

	Exhibit	
	Name	Page
Ordering -----	ALLR	5-1
Provisioning -----	ALLR	5-2
Field Work -----	ALLR	5-3



**Wholesale Non-recurring Study**

**Florida**  
**Dedicated Transit Service**  
**Table of Exhibits - Loaded Labor Rates by Exhibit**

	Exhibit Name	Page
Field Work _____	ALLR	5-3
Ordering _____	ALLR	5-1
Provisioning _____	ALLR	5-2

**Verizon - Florida  
Wholesale Non-recurring Study  
Loaded Labor Rates  
Ordering**

State	Work Center	Job Title	LLR per hour	LLR per minute
-------	-------------	-----------	--------------	----------------

Highlighted information is redacted for reason #2. Parties may obtain this information by signing a non-disclosure agreement.

**Verizon - Florida  
Wholesale Non-recurring Study  
Loaded Labor Rates  
Provisioning**

State	Work Center	Job Title	Job Duties	LLR per hour	LLR per minute
-------	-------------	-----------	------------	-----------------	----------------------

Highlighted information is redacted for reason #2. Parties may obtain this information by signing a non-disclosure agreement.

