



Leigh A. Hyer
Vice President-General Counsel, Southeast Region
Legal Department

FLTC0717
201 North Franklin Street (33602)
Post Office Box 110
Tampa, Florida 33601-0110

Phone 813 483-1256
Fax 813 204-8870
leigh.a.hyer@verizon.com

March 24, 2006

Ms. Blanca S. Bayo, Director
Division of the Commission Clerk
and Administrative Services
Florida Public Service Commission
2540 Shumard Oak Boulevard
Tallahassee, FL 32399-0850

Re: Docket No. 050419-TP
Petition of MCImetro Access Transmission Services, LLC for Arbitration of
Interconnection Agreement with BellSouth Telecommunications, Inc.

Dear Ms. Bayo:

Enclosed are an original and 15 copies of the Supplemental Testimony of Don Price
On Behalf of MCImetro Access Transmission Services, LLC d/b/a Verizon Access
Transmission Services for filing in the above-referenced matter. Service has been
made as indicated on the Certificate of Service. If there are any questions regarding
this filing, please contact me at 813-483-1256.

Sincerely,

Leigh A. Hyer

LAH:tas
Enclosures

DOCUMENT NUMBER-DATE

02692 MAR 24 06

FPSC-COMMISSION CLERK

CERTIFICATE OF SERVICE

I hereby certify that copies of the Supplemental Testimony of Don Price On Behalf of MCImetro Access Transmission Services, LLC d/b/a Verizon Access Transmission Services in Docket No. 050419-TP were sent via U.S. mail on March 24, 2006 to:

Staff Counsel
Florida Public Service Commission
2540 Shumard Oak Boulevard
Tallahassee, FL 32399-0850

BellSouth Telecommunications, Inc.
N. White/R. D. Lackey/J. Meza
c/o Nancy H. Sims
150 South Monroe Street, Suite 400
Tallahassee, FL 32301-1556

Verizon Communications
Dulaney L. O'Roark/Kennard B. Woods
Six Concourse Parkway, Suite 600
Atlanta, GA 30328

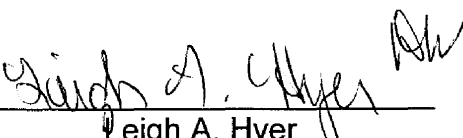

Leigh A. Hyer

BEFORE THE FLORIDA PUBLIC SERVICE COMMISSION

**In the Matter of: Petition of MCImetro Access
Transmission Services, LLC for Arbitration of
Interconnection Agreement with BellSouth
Telecommunications, Inc.**

Docket No. 050419-TP

**SUPPLEMENTAL TESTIMONY OF DON PRICE
ON BEHALF OF MCIMETRO ACCESS TRANSMISSION SERVICES, LLC
d/b/a VERIZON ACCESS TRANSMISSION SERVICES ("VERIZON ACCESS")**

March 24, 2006

TABLE OF CONTENTS

I. INTRODUCTION.....	1
II. PURPOSE OF TESTIMONY.....	3
III. UPDATE OF EVENTS	3
IV. ISSUES REMAINING IN DISPUTE	5
ISSUE 12: SHOULD VERIZON ACCESS BE REQUIRED TO INDEMNIFY BST FOR BST'S NEGLIGENCE FOR CLAIMS BY THIRD PARTIES WHO ARE NOT VERIZON ACCESS CUSTOMERS IN CONJUNCTION WITH BST'S PROVISION OF PBX LOCATE SERVICE TO VERIZON ACCESS?	5
ISSUE 22: A) SHOULD VIRTUAL NXX SERVICES OFFERED BY VERIZON ACCESS TO ITS CUSTOMERS BE TREATED AS LOCAL TRAFFIC OR SWITCHED ACCESS TRAFFIC FOR COMPENSATION PURPOSES. B) IF THEY SHOULD BE TREATED AS SWITCHED ACCESS TRAFFIC, HOW WILL SUCH TRAFFIC BE IDENTIFIED FOR PURPOSES OF THE SEPARATE TREATMENT?	9
ISSUE 26: IS BST OBLIGATED TO ACT AS A TRANSIT CARRIER? IF SO, WHAT IS THE APPROPRIATE TRANSIT RATE?.....	22
ISSUE 32: WHAT CHARGES, IF ANY, SHOULD BE IMPOSED FOR RECORDS CHANGES MADE BY THE PARTIES TO REFLECT CHANGES IN CORPORATE NAMES OR OTHER LEC IDENTIFIERS SUCH AS OCN, CC, CIC AND ACNA?	25
ISSUE 33: HOW SHOULD THE RATE FOR THE CALCULATION OF LATE PAYMENTS BE DETERMINED?	27
ISSUE 34: WHAT PROCESS SHOULD BE USED FOR THE DISCONTINUING OF SERVICE?	28
V. CONCLUSION.....	28

I. INTRODUCTION

Q. PLEASE STATE YOUR NAME AND BUSINESS ADDRESS.

A. My name is Don Price. My business address is 701 Brazos, Suite 600, Austin, Texas 78701.

Q. BY WHOM ARE YOU EMPLOYED AND WHAT IS YOUR POSITION?

A. I am employed by Verizon Business as Director – State Regulatory Policy in the Verizon Business Regulatory and Litigation department.

Q. WHAT IS YOUR PROFESSIONAL EXPERIENCE AND EDUCATIONAL BACKGROUND?

A. I have more than 27 years experience in telecommunications, most of which is in the area of public policy. For the past 11 years, my job responsibilities have focused on policy issues relating to competition in local telecommunications markets. I have testified in a number of state commission arbitration proceedings on a wide range of issues related to interconnection agreements between Verizon Business (formerly MCI) and incumbent local exchange carriers.

Shortly after passage of the federal Telecommunications Act of 1996 (“the Act”), I participated in the initial interconnection negotiations with SBC Communications Corporation. Those negotiations led to the first interconnection agreement between the SBC incumbent local exchange carrier (“ILEC”) affiliate in Texas and MCI, paving the way for MCI’s entry in 1997 into various Texas markets. Since that time, I have had continued involvement with competitive policy issues in MCI’s interconnection agreements with both BellSouth Telecommunications and SBC. In my current position, my responsibilities require

that I work closely with many different organizations in Verizon Business, including those involved with the products Verizon Business sells and those who engineer and construct Verizon Access's network.

My educational credentials include a Master of Arts degree from the University of Texas at Arlington in 1978, and a BA earned in 1977, also from U.T. Arlington.

- Q. HAVE YOU PREVIOUSLY TESTIFIED BEFORE ANY STATE COMMISSIONS?**
- A. Yes. I have testified before state regulators in twenty-two states. My detailed qualifications, including a list of the various proceedings in which I have provided testimony, are included in Attachment DGP-1.
- Q. WOULD YOU PLEASE EXPLAIN TO THE COMMISSION THE STATUS OF PETITIONER MCI IN LIGHT OF THE MERGER WITH VERIZON?**
- A. Yes. As the Commission is likely aware, the merger of Verizon and MCI closed on January 6, 2006. At completion of the merger, a new business unit called "Verizon Business" was created. This new Verizon Business unit encompasses large business and government customers and related functions of the former MCI, as well as similar businesses that previously were part of Verizon Telecom, including the former Verizon Enterprise Solutions Group. The products now sold to commercial and enterprise customers are marketed under the "Verizon Business" brand. As part of that branding, MCImetro Access Transmission Services LLC, which is part of Verizon Business, is now doing business as Verizon Access Transmission Services. Because of the new d/b/a, I use the term "Verizon Access" throughout my testimony instead of MCImetro or MCI.

Importantly, however, the creation of the new Verizon Business brand does not affect the status of MCImetro Access Transmission Services LLC as a legal and certificated entity, and the merger with Verizon did not change the relationship between the parties to this proceeding.

II. PURPOSE OF TESTIMONY

Q. WHAT IS THE PURPOSE OF YOUR SUPPLEMENTAL TESTIMONY?

A. My testimony is intended to accomplish two things. First, given the parties' continuing efforts to settle outstanding issues, I provide an update on events that have transpired since the filing of Verizon Access's direct and rebuttal testimony in this proceeding. Second, I furnish supplemental testimony outlining each issue that remains in dispute. To the extent that an issue has been modified through the parties' continuing discussions, or that Verizon Access's position on the issue has changed, I describe the nature of the remaining dispute and present Verizon Access's recommendation on how the Commission should decide the issue.

III. UPDATE OF EVENTS

Q. PLEASE DESCRIBE THE PARTIES' EFFORTS TO NARROW OR RESOLVE ISSUES PREVIOUSLY PRESENTED FOR RESOLUTION BY THE COMMISSION.

A. Verizon Access and BellSouth have sought to resolve or narrow as many of the disputed issues as possible. Review of the disputed issues matrix filed on March

3, 2006 is proof of just how far the parties have come in the last few months, reflecting the resolution of 14 issues. Since then two additional issues have been resolved.

Q. WHICH ISSUES HAVE BEEN ELIMINATED THROUGH THE PARTIES' CONTINUING NEGOTIATIONS?

A. The following issues have been resolved since testimony was filed in this proceeding:

Resolved Issue #	
1	19
2	23
3	24
9	25
11	27
15	29
17	30
18	31

Note that subparts A) and C) of Issue 17 were resolved, while subpart B) was merged into Issue 22. In addition, Issue 21 shown in the March 3, 2006 issues matrix has been resolved with respect to Florida.

Q. YOU STATED ABOVE THAT CERTAIN ISSUES HAVE EVOLVED OR BEEN NARROWED SINCE TESTIMONY WAS INITIALLY FILED IN THIS PROCEEDING. WOULD YOU PROVIDE A MORE DETAILED EXPLANATION REGARDING THOSE ISSUES?

A. Certainly. In the next portion of my testimony, I discuss each issue that remains in dispute. Where the dispute has evolved, I explain the nature of the dispute as it now stands. If the issue remains as initially described to the Commission and there is no change in the parties' position on that issue, I reference the relevant prefiled testimony as the testimony I will adopt at hearing. On the other hand, if

either the issue has changed or Verizon Access has modified its position on the issue, I present supplemental testimony to assist the Commission in resolving the dispute as it now stands.

IV. ISSUES REMAINING IN DISPUTE

Issue 12: Should Verizon Access be required to indemnify BST for BST's negligence for claims by third parties who are not Verizon Access customers in conjunction with BST's provision of PBX Locate Service to Verizon Access?

Contract Provisions: A2 – 7.4.2.2

Q. HAVE THE PARTIES BEEN ABLE TO NARROW THIS ISSUE?

A. Yes. Through additional negotiations and resolution of related issues, this issue has been narrowed, as reflected in the statement of the issue above and in the updated issues matrix filed March 3, 2006.

Q. ARE YOU PRESENTING SUPPLEMENTAL TESTIMONY ON THIS ISSUE?

A. Yes. In the following discussion, I explain the basis for Verizon Access's current position on this issue. This supplemental testimony is in addition to the prefiled testimony of MCI witness Greg Darnell on this issue – his direct testimony dated October 21, 2005 (pp. 32-33) and his rebuttal testimony dated December 1, 2005 (pp. 22-24) – that I will adopt at the hearing.

Q. WHAT IS THE DISPUTED LANGUAGE ON THIS ISSUE?

A. The language to which Verizon Access takes issue is the BellSouth proposed language (in bold underline) in the following paragraph. MCI's proposed language is in plain text.

MCI agrees to release, indemnify, defend and hold harmless BellSouth from any and all loss, claims, demands, suits, or other action, or any liability whatsoever, whether suffered, made, instituted or asserted by MCI's customer or by any other party or person, for any personal injury to or death of any person or persons, or for any loss, damage or destruction of any property, whether owned by MCI or others, or for any infringement or invasion of the right of privacy of any person or persons, caused or claimed to have been caused, directly or indirectly, by the installation, operation, failure to operate, maintenance, removal, presence, condition, location or use of PBX Locate Service features or by any services which are or may be furnished by BellSouth in connection therewith, including but not limited to the identification of the telephone number, address or name associated with the telephone used by the party or parties accessing 911 services using 911 PBX Locate Service hereunder, except to the extent caused by BellSouth's gross negligence or wilful misconduct. MCI is responsible for assuring that its authorized customers comply with the provisions of these terms and that unauthorized persons do not gain access to or use the 911 PBX Locate Service through user names, passwords, or other identifiers assigned to MCI's customer or DMA pursuant to these terms. Specifically, MCI's customer or DMA must keep and protect from use by any unauthorized individual identifiers, passwords, and any other security token(s) and devices that are provided for access to this product.

Q. WHAT ARE VERIZON ACCESS' CONCERNS WITH BELLSOUTH'S LANGUAGE?

A. The primary concern is the astonishing breadth of BellSouth's language, which goes far beyond Verizon Access's relationship with its own customers. The BellSouth language would have Verizon Access indemnify BellSouth against "... any and all loss, claims, demands, suits, or other action, or any liability whatsoever, whether suffered, made, instituted or asserted by ... any other party or person"

Q. WHAT IS THE APPROPRIATE SCOPE OF VERIZON ACCESS'S INDEMNIFICATION OBLIGATION?

A. The indemnification obligation should be the same as what the parties have agreed to for other services. In the General Terms and Conditions of the interconnection agreement (“ICA”) being arbitrated, Verizon Access has agreed to indemnify BellSouth against BellSouth’s simple negligence resulting in a claim from a Verizon Access customer, but not against BellSouth’s gross negligence or intentional misconduct. This indemnification covers all services in the ICA, including PBX Locate Service. Thus, Verizon Access has agreed to indemnify BellSouth against BellSouth’s simple negligence in providing PBX Locate Service where such negligence results in a claim from a Verizon Access customer. Verizon Access believes that its proposed language is reasonable and should be adopted.

Q. PLEASE CONTINUE.

A. Verizon Access has a direct relationship with its own customers, and can include in its tariffs and contracts with those customers provisions to limit liability. Thus, Verizon Access can control the exposure and risk associated with the indemnification for claims from Verizon Access’s own customers. Verizon Access does not, however, have a similar relationship with unknown persons in the general public. Verizon Access has no control over what claims may be brought by the general public, and there is no reason why it should have to indemnify BellSouth against claims from the general public. That is a service sold by insurance companies. If BellSouth desires such coverage, it should buy insurance.

Q. IS BELLSOUTH'S RATIONALE FOR ITS POSITION ON THIS ISSUE CONSISTENT WITH ITS PROPOSED CONTRACT LANGUAGE?

A. No, I do not believe it is. BellSouth's position statement begins with the following assertion:

BellSouth is not requiring any more restrictions or obligations to MCI [sic] than BellSouth requires or obligates its own retail customers for retail equivalent service.

The relationship between BellSouth and its retail customer with respect to PBX Locate Service is very different than the relationship between BellSouth and Verizon Access. When BellSouth provides the PBX Locate Service to a BellSouth retail customer, that retail customer is in a reasonable position to control – and therefore indemnify for – claims by third parties on that customer's premises. But when BellSouth provides the service to Verizon Access as part of the ICA, it is for use by a customer of Verizon Access, rather than by Verizon Access itself. This is a critical difference from the BellSouth retail situation, because, unlike BellSouth's retail customer, Verizon Access is in no position to control or supervise the activities of fourth-party users of the end-user customer's premises.

Q. DO YOU HAVE ADDITIONAL COMMENT ON THIS ISSUE?

A. Yes. Although I am not an attorney, it is my understanding that provisions in the Florida statutes (§365.171(14)) provide civil immunity to a telephone company such as BellSouth in conjunction with its operation of a 9-1-1 system. Coupling that statutory provision with the indemnification and limitation of liability language in the General Terms and Conditions section of the ICA, Verizon Access believes

BellSouth's concerns on this issue should be satisfied. Verizon Access's position on this issue should be adopted.

Issue 22: A) Should virtual NXX services offered by Verizon Access to its customers be treated as local traffic or switched access traffic for compensation purposes. B) If they should be treated as switched access traffic, how will such traffic be identified for purposes of the separate treatment?

Contract Provisions: A3 – 7.1, 7.5.4, 7.5.5

Q. HAS THERE BEEN A CHANGE IN THE SCOPE OF THIS ISSUE?

A. No. Although Issue 17 B) has been merged into this issue, the statement of the issue remains the same. Verizon Access has modified its position, however, and presented that modified position to BellSouth in an effort to resolve the issue. Notwithstanding the parties' continuing discussions, the issue remains as previously presented to the Commission.

Q. ARE YOU PRESENTING SUPPLEMENTAL TESTIMONY ON THIS ISSUE?

A. Yes. The following discussion provides an explanation of Verizon Access's modified position, beginning with background information to put this complex issue in context.

Q. CAN YOU BRIEFLY EXPLAIN THE ESSENCE OF THE HISTORIC DIFFERENCES IN THE PARTIES' POSITIONS ON THIS ISSUE?

A. Yes. The parties' differences revolve around the following questions: 1) which entity is entitled to compensation for handling the particular type of network traffic referred to as "virtual NXX" traffic, and 2) at what rate level is compensation to be paid?

Q. WHAT IS “VIRTUAL NXX” TRAFFIC AND WHY IS SUCH TRAFFIC DIFFERENT FROM OTHER TYPES OF TRAFFIC THAT THE PARTIES EXCHANGE?

A. The answer to this question requires a brief discussion of the operation of legacy ILEC networks for purposes of contrasting the design and operation of Verizon Access’s CLEC network.

Because of their long histories in operating telephony networks, ILEC network design remains essentially the same as it was in the first half of the 20th Century. That basic network design consists of a hub-and-spoke architecture with a switch located centrally in each “exchange.” The switch located in each exchange provides dial tone service to customers within that relatively small geographic area, and customers in the area share the same NPA/NXX – e.g., 305-372 – as the first part of each unique 10-digit telephone number. Stated differently, the phone numbers assigned in that area are all assigned from the same NPA/NXX. This represents a slight oversimplification because switches in more populous exchanges may utilize several NXXs to serve the customers in the area.¹ An ILEC such as BellSouth that serves large geographic areas would in this manner have many “exchanges,”² with a switch physically located in each exchange, and with each switch containing only those few NPA/NXXs required for number assignments within that exchange.

¹ A single NXX contains 10,000 individual phone numbers.

² The term “exchange” is sometimes synonymous with the term “rate center” and/or “local calling area.” Particularly in metropolitan areas, however, a “rate center” may encompass numerous exchanges in a large local calling area.

Verizon Access's CLEC networks do not share this historical heritage, nor do they share the same network design. Most CLEC networks were designed in the late 1990s based on then-current design principles and technologies to efficiently meet the contemporary needs of their new customer bases. For these reasons, in contrast to legacy ILEC networks, CLEC networks typically use many fewer switches to serve an area comparable to numerous ILEC exchange areas. Unlike the traditional hub-and-spoke ILEC network design, there is not a one-for-one correspondence between CLEC switches and a particular exchange, and it is not unusual for a single CLEC switch to contain many more NPA/NXXs than reside in one ILEC switch. A single Verizon Access switch in Orlando, for example, utilizes 40 NXXs in three different NPAs to serve Verizon Access's customers within the LATA.

Telecommunications traffic does not arrive at the correct destination switch by magic, but rather on the basis of industry standard, regularly published routing rules -- the Local Exchange Routing Guide (or, "LERG") -- that must be honored by all carriers: ILECs, wireless ("CMRS") carriers, and interexchange carriers.³ For any carrier to receive traffic from another carrier, at least one NPA/NXX code must be "activated" in the LERG (and in the carrier's switch) for a specific geographic area. For purposes of the LERG, the relevant geographic

³ The LERG is constantly maintained so that all carriers will have the latest information on how to route calls to each others' networks.

areas are "rate centers," as defined by the ILECs' service territories and state-approved tariffs.⁴

With this in mind, a CLEC activating an NPA/NXX in the LERG assigns the NPA/NXX to a specific rate center based on internal business decisions as to the area within which it offers service. The assignment of that NPA/NXX to a particular rate center by the CLEC means that other customers within that rate center can reach the CLEC's customers using a local dialing plan -- i.e., without having to dial 1+.

Q. IS THERE A FLORIDA EXAMPLE YOU COULD PROVIDE?

A. Yes. For example, the LERG contains information for BellSouth's Cocoa, Florida service territory that identifies the appropriate switch or switches in the BellSouth network to which a call should be sent so it can be delivered in Cocoa. For incoming calls from interexchange carriers, the designation likely would be an access tandem (also known as a toll tandem) somewhere in the LATA. For calls from another LEC (including a CLEC), the designation would perhaps be a local tandem in the vicinity. In either case, the call would be handed from the BellSouth tandem to the local central office serving the particular NPA/NXX of the called party in Cocoa. That ILEC switch is probably located in or near Cocoa.

Similarly, in the case of calls destined for Verizon Access's network, the LERG also identifies the appropriate Verizon Access switch for delivery of a call

⁴ A rate center may be synonymous with the "exchange" concept I have described. Or, it may encompass numerous exchanges that make up a large metropolitan local calling area, depending on the ILEC's tariffs and prior regulatory decisions in the state.

in the same Cocoa, Florida rate center. As noted above, the LERG identification is based on assignments by the respective carriers rather than where the switches are located, especially for non-legacy CLEC networks, like Verizon Access's. As a result, the Verizon Access switch serving Cocoa may well be located elsewhere in the LATA (e.g., Orlando).

Q. WITH THIS BACKGROUND INFORMATION, COULD YOU PROVIDE AN ILLUSTRATION TO HELP EXPLAIN THE OPPOSING VIEWS ON COMPENSATION?

A. Yes. Following are two schematics representing two call situations. The comparison between the two scenarios is designed to underscore both their similarities and differences, and thus highlight the traditional views of ILECs and CLECs on compensation.

Local Call Example: ILEC to CLEC

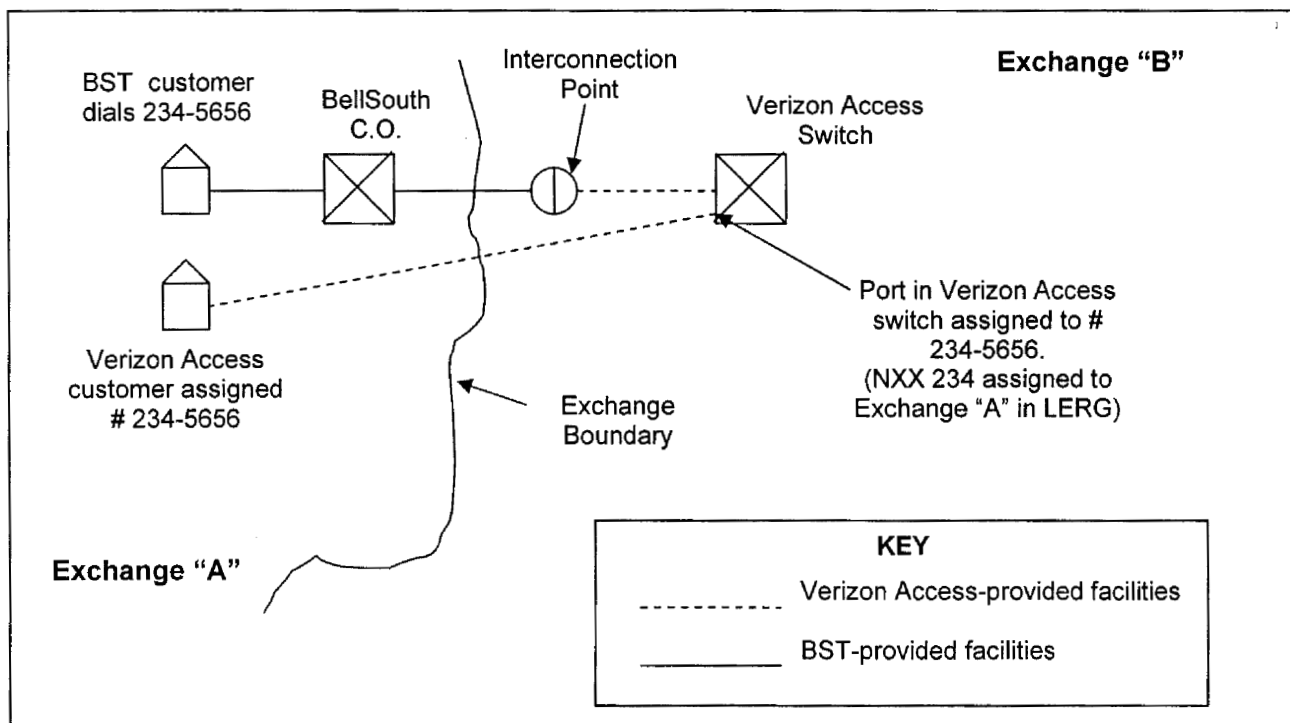

"vNXX" Call Example: ILEC to CLEC

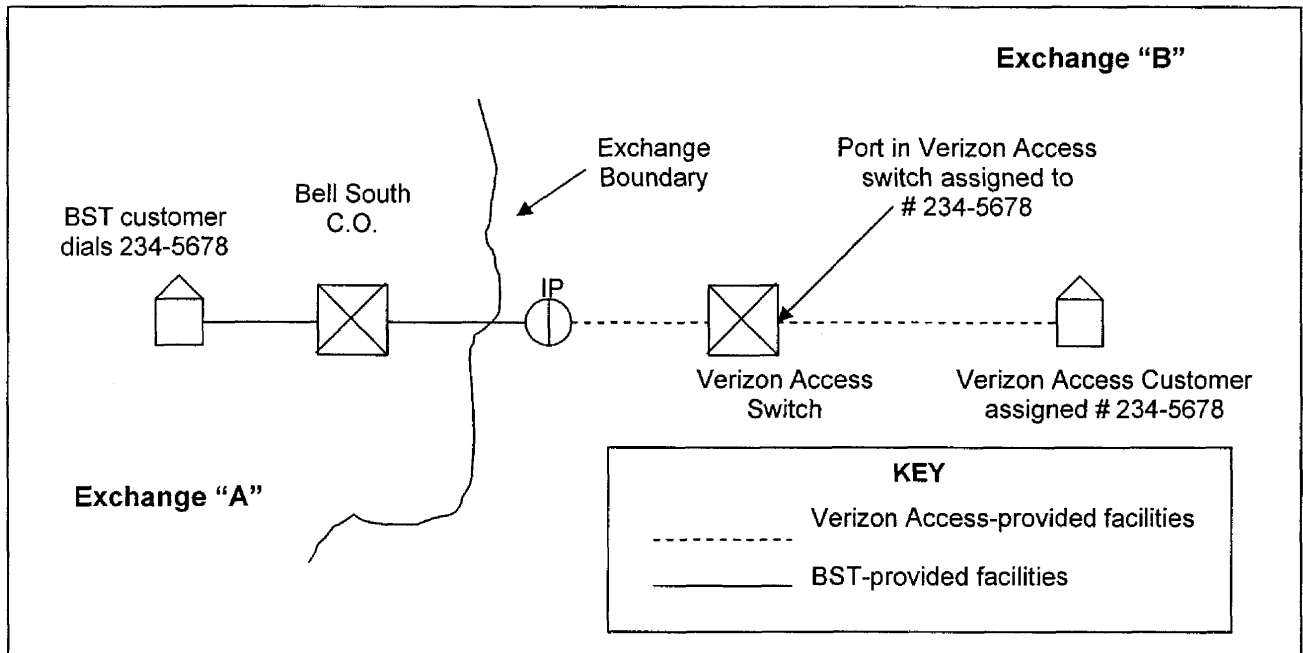

Q. WHAT ARE THE SIMILARITIES IN THE TWO SCENARIOS?

A. In both scenarios, the calls from the BellSouth customer to the Verizon Access customer are handled by both carriers in precisely the same manner. In both scenarios, BellSouth's switch routes its customer's call to interconnection trunks with Verizon Access, and BellSouth hands the call off to Verizon Access at the Interconnection Point, or "IP." And in both scenarios, when Verizon Access recognizes the incoming call from the BellSouth customer, it switches that call to the appropriate facility for termination to its customer. Note that the LERG assignment of the "234" NXX by Verizon Access is for BellSouth's Exchange "A" rate center.

Q. WHAT ARE THE DIFFERENCES BETWEEN THE TWO SCENARIOS?

A. There is only one difference between the two scenarios, and that is the location of the Verizon Access customer. In the first “Local Call Example” scenario, both the BellSouth and the Verizon Access customers’ locations are in Exchange “A” (as defined by BellSouth). In the second “vNXX Call Example” however, the Verizon Access customer’s location is no longer in the same Exchange “A” as the BellSouth customer. (The industry has coined the term “virtual NXX” or “vNXX” to apply to this second situation in which the Verizon Access customer in Exchange B (as defined by BellSouth) has been assigned a telephone number (NXX) associated with the Exchange “A” rate center.) That one difference between these two scenarios serves to illustrate the policy dispute within the industry on vNXX traffic.

Q. USING THE ILLUSTRATIONS AND YOUR DISCUSSION, BRIEFLY SUMMARIZE THE TRADITIONAL OPPOSING VIEWS OF CLECS AND ILECS ON VNXX COMPENSATION.

A. The traditional CLEC perspective derives from two basic points. First, the CLEC’s LERG assignment for the NXX – 234 in the illustrations – was made for the Exchange “A” rate center. Calls to numbers assigned to the same rate center are typically rated as “local” for retail billing to the calling party. Second, following from the previous point, the CLEC view is based on an interpretation of the Act and the FCC’s rules that it should receive the compensation applicable to local calls – “reciprocal compensation” – for the functions it provides in terminating the traffic from the ILEC’s customer.

The traditional ILEC perspective arises from their historic position as providers of exchange access services to interexchange carriers. In the

exchange access arena, ILECs are entitled to compensation for the access functions they provide to originate jurisdictionally interexchange "toll" calls to interexchange carriers. This "jurisdictional" view is reflected in BellSouth's position statement on Issue 22, which states in part:

The physical end points of a call are the appropriate mechanism for determining jurisdiction.

As this discussion has explained, the ILEC and CLEC positions on the jurisdictional nature of such traffic are diametrically opposite. The ILEC position is that, because it is providing an originating exchange access function, it should be compensated according to its switched access tariffs. ILECs have also expressed concern that vNXX traffic may increase the amount of traffic for which the ILEC is providing a substantial amount of transport without compensation, especially if the CLEC has only a single point of interconnection in the LATA.

From the CLEC perspective, it is terminating or handling "local" traffic originated by another LEC and is thus entitled to compensation for the functions it provides in handling traffic originated by the ILEC's customers. The nature of the dispute is further complicated by fact that the overwhelming majority of virtual NXX traffic is dial-up Internet traffic (that is, Internet service providers have been assigned most of the vNXX telephone numbers). The ILECs' customers are dialing these virtual NXX numbers with their computer modems for purposes of accessing Internet service providers such as America Online, Microsoft Networks, Earthlink and others.

Q. AS YOU HAVE EXPLAINED THE ILEC VERSUS CLEC VIEWS ON THIS ISSUE, IT SEEMS THAT THE ISSUE CRIES OUT FOR INDUSTRY-WIDE RESOLUTION. HAS THE FCC ATTEMPTED TO PROVIDE CLARITY ON THIS MATTER?

A. Yes. The FCC has attempted to clarify applicable law and its rules regarding such intercarrier compensation, but disputes nonetheless frequently have been brought before the states – often, as here, in the form of a request for arbitration. Recognizing this reality, the FCC has expressed its intention to deal with this matter in its broad rulemaking on intercarrier compensation issues.⁵ Any solution reached in this arbitration should recognize the FCC's role and should therefore be interim pending nationwide action by the FCC. The interconnection agreement should contemplate rapid implementation in Florida, on a going-forward basis, of any new national intercarrier compensation program following its adoption by the FCC.

Q. GIVEN THE ABOVE, IS RESOLUTION ON A STATE-BY-STATE BASIS THROUGH ARBITRATION PROCEEDINGS THE BEST WAY TO RESOLVE THE PARTIES' DISPUTE ON THIS ISSUE IN THE INTERIM?

A. No. A state-specific resolution is clearly not ideal, even while waiting for FCC action. It creates the likelihood that different outcomes will be ordered by different states as each commission decides the issue independently. Such a result will create billing and invoicing problems between Verizon Access and BellSouth as the carriers seek to implement the disparate outcomes across the nine-state BellSouth region. In part to avoid such problems in other regions,

⁵ *In the Matter of Developing a Unified Intercarrier Compensation Regime*, Notice of Proposed Rulemaking, CC Docket No. 01-92 (rel. April 27, 2001), at ¶ 115.

Verizon Access (and other CLECs) have been able successfully to negotiate and implement region-wide agreements with SBC (prior to the January 31, 2005 announcement of its merger with AT&T Inc.) and with Verizon (before the February 14, 2005 announcement of the Verizon-MCI merger).

These multi-state agreements are superior to disparate, state-specific regulatory outcomes. First, such agreements avoid the uncertainty associated with state-by-state litigation. Second, because they apply across a broad geographic area, these agreements do not create the sorts of billing and invoicing problems described above. Third, because the agreements are the product of arm's-length bilateral negotiations, they allow both parties to give appropriate weight to their respective business interests and achieve an outcome that reflects a balanced marketplace solution to what would otherwise be a thorny regulatory problem. In sum, these remarkably similar intercarrier agreements present a win-win market solution, instead of the traditional polarized win-lose outcome of regulatory decision-making.

Q. WOULD YOU PLEASE DESCRIBE THE PRIMARY ELEMENTS CONTAINED IN THE NEGOTIATED AGREEMENTS WITH WHICH YOU ARE FAMILIAR?

A. Yes. In essence, these agreements all provide that the CLEC is entitled to some compensation for handling virtual NXX traffic (that is ISP-bound traffic) originated by the ILEC, in exchange for, among other things, some commitment by the CLEC to extend its network deeper toward the ILEC, thereby reducing the ILEC's cost of transporting the traffic. The level of compensation provided for by the agreement varies from one agreement to another. Similarly, the CLEC's network

commitment differs between agreements, but is typically tied to the ILEC architecture in a given region.⁶

In Verizon Access's experience, its commitment to extend its CLEC network toward the ILEC addresses the traditional ILEC concern that ILECs bear a disproportionate burden in interconnecting with CLECs. The two largest ILECs – AT&T, Inc. (formerly SBC) and Verizon – were willing to abandon their litigation positions and agreed to compensate Verizon Access for various types of traffic, including virtual NXX traffic (that is ISP-bound traffic), in exchange for a commitment by Verizon Access to build its network closer to the originating points of the traffic, such as by interconnecting at or near each ILEC tandem, rather than just at a single point in the LATA.

Q. YOU ALSO NOTED ABOVE THAT THE PARTIES TO THESE MULTI-STATE AGREEMENTS HAVE RESOLVED THE QUESTION OF COMPENSATION FOR VNXX TRAFFIC. COULD YOU ELABORATE ON THIS POINT?

A. Yes. The Verizon/MCI agreement resolved the issue by establishing a “unitary rate.” That is, by agreement of the parties, compensation for ISP-bound vNXX traffic is paid at a single, uniform rate across all the states in which the parties exchange traffic, without regard to the state-specific rate established for reciprocal compensation pursuant to § 251 of the federal Telecommunications Act. In that agreement, ISP-bound vNXX traffic is compensated at a single blended rate (a blend of the varying rates that may be applicable in various

⁶ For example, former MCI's agreement with former SBC imposes different network obligations on MCI in the old Southwestern Bell territory than in the old Ameritech operating territory, in recognition of architectural differences between those ILEC regions.

jurisdictions) that is capped at the level of \$0.0007 per minute of use, the default rate for information services traffic established by the FCC in its “ISP Remand Order.”⁷

The MCI/SBC agreement also uses a “blended rate” that recognizes the various types of traffic exchanged (such as voice traffic and dial-up Internet traffic), and the effective blended rate varies by state to give meaning to each state commission’s established reciprocal compensation rate. That said, the effective compensation rate Verizon Access receives for traffic it receives from and terminates for SBC is slightly below 1/10th cent per minute – close to the capped rate negotiated between Verizon and MCI.

These “Unitary Rate Agreements” negotiated by either the Verizon ILECs or the former SBC ILECs with major CLECs – and then adopted by yet more CLECs – appear to represent a relatively consistent marketplace resolution by sophisticated adversaries of an otherwise difficult regulatory problem.

Q. HAS MCI APPROACHED BELLSOUTH TO DISCUSS THE POSSIBLE SETTLEMENT OF ISSUE 22 ALONG THE LINES OF THE AGREEMENTS YOU HAVE JUST DESCRIBED?

A. Yes. Having successfully negotiated such agreements with the nation’s two largest BOCs that apply to traffic carried throughout 42 states, Verizon Access sought to reach a similar agreement with BellSouth in the southeastern United

⁷ *In the Matter of Implementation of the Local Competition Provisions of the Telecommunications Act of 1996, Intercarrier Compensation for ISP-Bound Traffic*, Order on Remand and Report and Order, CC Docket No. 96-98; CC Docket No. 99-68, ¶ 78 (rel. April 27, 2001). My description of the MCI/Verizon agreement above is intended to address only the key elements, and does not cover all the detailed provisions in the agreement.

States. The proposal presented by Verizon Access to BellSouth was in large part an amalgam of the above-referenced commercial agreements into which the former MCI has entered.

Q. PLEASE ELABORATE.

A. Verizon Access proposed to BellSouth that compensation for the termination of vNXX traffic would be linked to the scope of Verizon Access's interconnection network with BellSouth. For each LATA, Verizon Access would be entitled to compensation for ISP-bound virtual NXX traffic that is originated by BellSouth customers and handled by Verizon Access only if it establishes at least one Interconnection, or IP, at each BellSouth tandem. Under that proposal, if Verizon Access meets that condition, BellSouth would compensate Verizon Access at the rate of \$0.0007 – the default ISP-bound access rate set by the FCC.

In a LATA where Verizon Access does not establish at least one IP at each BellSouth tandem, Verizon Access under its proposal would agree to forego compensation for such traffic; the parties instead would exchange traffic in that LATA on a bill-and-keep basis – meaning that neither party would receive compensation from the other party for this traffic.

Q. GIVEN THE ABOVE, WHAT IS YOUR RECOMMENDATION TO THE COMMISSION FOR RESOLUTION OF THIS ISSUE?

A. Even if BellSouth does not agree to resolve the issue in the manner I have described, Verizon Access believes the Commission can look to this marketplace solution as a guide to a reasonable interim resolution of the vNXX issue in this case. As I have explained, Verizon Access's modified position represents a

significant departure from the typical CLEC litigation position, and is based instead on commercial agreements successfully entered into with major BOCs in the absence of regulatory intervention. For this reason, Verizon Access believes its modified position represents a "middle ground" that this Commission can adopt in this arbitration, pending final resolution of intercarrier compensation issues by the FCC.

Issue 26: Is BST obligated to act as a transit carrier? If so, what is the appropriate transit rate?

Contract Provisions: A3 – 7.10.2, pricing attachment

Q. HAS THERE BEEN A CHANGE IN THE SCOPE OF THIS ISSUE?

A. No, the scope of the issue remains as originally presented to the Commission. As reflected in the updated issues matrix dated March 3, 2006, however, Verizon Access has modified its position. For this reason, I am presenting supplemental testimony on this issue.

Q. TO AID THE COMMISSION AND PROVIDE CONTEXT FOR THIS ISSUE, WOULD YOU PLEASE BRIEFLY EXPLAIN WHAT YOU MEAN BY THE PHRASE "THE TRANSIT FUNCTION?"

A. Certainly. As that phrase is used in my testimony, "the transit function" is the function of switching traffic that neither originates from, nor terminates to, a BellSouth customer. Because of BellSouth's historic position as the largest (and oldest) provider of telecommunications services within its service areas, BellSouth is sometimes in the position of performing the "transit function."

BellSouth continues to serve many more customers within its service areas than other carriers. For this reason, virtually every carrier operating in a

given area requires interconnection with BellSouth to exchange calls with BellSouth's customers in that area. The following hypothetical will help demonstrate this point.

We will assume that BellSouth serves 80% of the customers in its service areas, and further assume two competing carriers – Carrier "A" and Carrier "B" – who each serve 4% of the customers within that same geographic area. If traffic generally is proportionate to the percentage of customers served, there is a very high probability (80%) that any call generated by a customer of either Carrier "A" or Carrier "B" is destined for a BellSouth customer. And the same is true as to traffic *to* a customer of either Carrier "A" or Carrier "B." Because BellSouth has the predominant customer base, its customers will generate a much higher amount of traffic in total than the traffic generated by much smaller carriers.

Shifting the focus of our hypothetical, consider the likelihood of traffic being exchanged between Carrier "A" and Carrier "B." Because both carriers have small customer bases, the probability that a call from one of their customers is destined to a customer of another is quite small – roughly equivalent to their 4% customer share. Similarly, the total amount of traffic exchanged between Carrier "A" and Carrier "B" is much smaller than the amount that either exchanges with BellSouth.

Q. WHAT CONCLUSION SHOULD BE DRAWN BASED ON YOUR HYPOTHETICAL?

A. The hypothetical demonstrates that the networking focus of any carrier with a small customer base -- such as our hypothetical Carrier "A" or Carrier "B" – is to

ensure that interconnection exists for the preponderance of the carrier's traffic: the traffic it exchanges with BellSouth. Such *direct* interconnection with BellSouth is essential, but the same is not true with respect to traffic the smaller carriers exchange with each other. And, the fact that both of the smaller carriers directly interconnect with BellSouth allows them to exchange traffic with each other *indirectly* using their existing direct interconnections with BellSouth.

"The transit function" is the phrase used to describe what BellSouth provides in the situation where a customer of one of these smaller carriers places a call to a customer of another such carrier. Where both carriers are directly interconnected with BellSouth, the call "transits" BellSouth's switching network even though no BellSouth customer is involved in the call. For all the reasons discussed above, this "transit function" accounts for a relatively small portion of the overall traffic switched by BellSouth.

Q. PLEASE CONTINUE WITH YOUR PRESENTATION OF SUPPLEMENTAL TESTIMONY ON ISSUE 26.

A. During negotiations, the parties discussed BellSouth's intentions for providing the transit function, and were able to agree on language in section A2-7.4.2.2 obligating BST to perform transit functionality. Notwithstanding that agreement, however, the parties were unsuccessful in negotiating a rate for that transit function BST has agreed to provide. The rate level for the transit function is the sole remaining dispute on this issue before the Commission, and it is ripe for resolution.

Q. HAS BELL SOUTH PROVIDED JUSTIFICATION FOR THE RATE LEVEL IT HAS PROPOSED?

A. No.

Q. IN THE ABSENCE OF SUCH JUSTIFICATION BY BELLSOUTH, WHAT ARE THE COMMISSION'S CHOICES AS TO RATES FOR THE TRANSIT FUNCTION PERFORMED BY BELLSOUTH?

A. Absent evidence demonstrating that Bell South's proposed rates are just and reasonable, the Commission really has no choice but to rely on the rates it previously approved as compensatory for the transit function. It is my understanding that the issue of the appropriate compensation for the transit function is being considered by the Commission at this time in Docket Nos. 050119-TP and 050125-TP. Should the Commission determine a new rate or rates for the transit function when provided by BellSouth, that new rate would be incorporated into the BellSouth/Verizon Access ICA in accordance with the ICA's provisions in the General Terms and Conditions section pertaining to change of law.

Issue 32: What charges, if any, should be imposed for records changes made by the Parties to reflect changes in corporate names or other LEC identifiers such as OCN, CC, CIC and ACNA?

Contract Provisions: A7 – 1.14.1

Q. HAS THERE BEEN A CHANGE IN THE SCOPE OF THIS ISSUE?

A. No. However, I am offering supplemental testimony on this issue to refocus the Commission's attention on the true nature of the dispute.

Q. WHAT IN VERIZON ACCESS'S VIEW IS THE "TRUE NATURE OF THE DISPUTE" ON THIS ISSUE?

A. The heart of the dispute is that, during negotiations, BellSouth raised this issue of charging Verizon Access for certain “records changes” that might be made to reflect identifiers used in billing. Although BellSouth raised the issue, it does not propose any charges. It is Verizon Access’s position that the open-ended language BellSouth is proposing should be rejected, as the Commission should not be asked to approve what is in effect a “blank check.”

Q. DO YOU HAVE ADDITIONAL INFORMATION THAT WOULD BE USEFUL TO THE COMMISSION IN RESOLVING THIS DISPUTE?

A. Yes. As the Commission is no doubt aware, Verizon Access’s predecessor company was part of the bankruptcy proceedings in the Bankruptcy Court for the Southern District of New York that involved MCI and its corporate parent and affiliates. Although I am not an attorney, it is my understanding as a layman that the Court expressly authorized the reorganization of those companies, including the mergers of MCI and affiliated local exchange carriers, and transfers of local exchange-related assets to MCI from other affiliated carriers. The MCI Plan of Reorganization in the bankruptcy case precludes carriers, including BellSouth, from assessing charges on MCI for the consolidation of entities carried out pursuant to the Plan. The bankruptcy court entered an order approving the Plan. BellSouth was a party to the bankruptcy cases and is therefore bound by the court’s order. To the extent BellSouth seeks recovery of costs relating to such mergers and transfers, it is foreclosed by the bankruptcy court’s order.

For the reasons I have discussed, the Commission should dismiss this issue. If, however, the Commission chooses not to dismiss this issue, it should

expressly reject the open-ended language proposed by BellSouth giving it the discretion to charge anything it likes for records changes.

Issue 33: How should the rate for the calculation of late payments be determined?

Contract Provisions: A7 – 1.17

Q. HAS THERE BEEN A CHANGE IN THE SCOPE OF THIS ISSUE?

A. No, the scope remains the same, although Verizon Access has presented an updated proposal to BellSouth in an effort to resolve the issue. I am presenting supplemental testimony to explain Verizon Access's proposal.

Q. PLEASE DESCRIBE VERIZON ACCESS'S NEW PROPOSAL.

A. Verizon Access proposed language to BellSouth setting the rate for late payment at either 18%, or the rate set by applicable law, whichever is less. BellSouth rejected that offer. If the applicable law in a given state provides for a rate less than 18%, then the rate set by state law would – indeed, should -- apply. Verizon Access is unable to understand BellSouth's reasoning in rejecting the proposal. Verizon Access's proposal is reasonable, and the Commission should adopt the proposal in resolution of this issue. As an alternative, Verizon Access also has proposed that the parties be allowed to charge **any** rate less than or equal to a maximum. In this alternative, the maximum would be the lesser of 18% or the maximum amount allowed by law. This alternative would permit BellSouth to apply the various rates that it prefers to use, but such rates would be capped.

Issue 34: What process should be used for the Discontinuing of Service?

Contract Provisions: A7 – 1.19

Q. HAS THERE BEEN A CHANGE IN THE SCOPE OF THIS ISSUE?

A. Yes. Issue 34 previously involved disputes over non-payment of a requested deposit and non-payment of disputed amounts, but those disputes have been resolved. The remaining dispute concerns the suspension, discontinuance or termination of all Verizon Access services region-wide for nonpayment of an undisputed bill for any service in any state, regardless of the size of the bill. I will thus adopt at hearing the prefiled testimony of MCI witness Greg Darnell on this issue – his direct testimony dated October 21, 2005 (pp. 50-52) and his rebuttal testimony dated December 1, 2005 (pp. 28-30).

V. CONCLUSION

Q. DOES THIS CONCLUDE YOUR TESTIMONY?

A. Yes, at this time.

**DON PRICE
ACADEMIC AND PROFESSIONAL QUALIFICATIONS, AND
TESTIMONY PRESENTED BEFORE
REGULATORY AGENCIES**

Academic Background:

My academic background is in the social sciences. I received my Bachelor of Arts degree in Sociology from the University of Texas at Arlington May of 1977 and was awarded a Master of Arts degree in Sociology by the University of Texas at Arlington in 1978.

Professional Qualifications:

I have more than 27 years experience in telecommunications, the vast majority of which is in the area of public policy. In the early 1980s I was employed by GTE in the Southwest operating company territory where I held several positions of increasing responsibility in Economic Planning. In those positions I became quite familiar with local exchange telephone company functions such as the workings and design of the local exchange switching and outside plant networks, the network planning process, business office operation, and the design and operation of large billing systems.

At the time of the divestiture of the Bell Operating Companies from the AT&T system in January, 1984, I was employed by the Public Utility Commission of Texas where I was responsible for analysis and expert testimony on behalf of the public interest on a variety of policy and rate setting issues. In 1986 I was promoted to Manager of Rates and Tariffs, and was directly responsible for staff analyses of rate design and tariff policy issues in all telecommunications proceedings before the PUC.

In late 1986, I was hired into the MCI Regulatory organization to provide rate and tariff analyses affecting MCI's growing long distance business. Over my nineteen years with MCI, my job functions were focused on public policy issues relating to competition in telecommunications markets. When MCI acquired Western Union Access Transmission

Services in 1993, that public policy focus narrowed to issues pertaining to competition in local telecommunications markets. Since that time, I have been involved directly and indirectly in contract negotiations for interconnection agreements, including a landmark agreement with Bell South that predated passage of the 1996 Telecommunications Act, and have presented policy testimony in numerous state arbitrations. The key aspects of my role were to develop, coordinate, and communicate MCI's public policy positions working with all affected internal client groups, including marketing and sales, network planning and engineering, and to articulate those positions to external decision-makers.

On January 6, 2006, with the close of Verizon's merger with MCI, I assumed my current position as Director --- State Regulatory Policy in Verizon Business' Regulatory and Litigation department. In that position, I am involved with various corporate departments in developing and coordinating policies that permit Verizon Business to offer the variety of enterprise and wholesale products demanded by our customers.

I have appeared as a panelist and/or speaker before various professional and trade associations and public seminars during my professional career, including the Texas Society of CPAs, the University of Texas Department of Electrical and Computer Engineering Telecommunications Conference, the Alabama Telephone Association, the Arkansas Telephone Association, and the National Association of Regulatory Utility Attorneys.

I have testified before a number of regulatory commissions, including the Federal Communications Commission, and the state regulatory bodies in Arizona, Arkansas, California, Colorado, Florida, Georgia, Illinois, Kansas, Kentucky, Louisiana, Minnesota, Missouri, New Jersey, Nevada, North Carolina, Ohio, Oklahoma, Oregon, South Carolina, Tennessee, Texas, and Washington. A list of those proceedings in which I have furnished testimony is provided below.

Testimony Presented:

FCC

CC Docket No. 00-4: In the Matter of Application by SBC Communications, Inc., Southwestern Bell Telephone Company, and Southwestern Bell Communications Services, Inc. d/b/a Southwestern Bell Long Distance for Provision of In-Region, InterLATA Services in Texas

Arkansas

Docket No. 91-051-U: IN RE IMPLEMENTATION OF TITLE IV OF THE AMERICANS WITH DISABILITIES ACT OF 1990

Docket No. 92-079-R: IN THE MATTER OF A PROCEEDING FOR THE DEVELOPMENT OF RULES AND POLICIES CONCERNING OPERATOR SERVICE PROVIDERS

Arizona

Docket No. T-00000A-97-238: IN THE MATTER OF U S WEST COMMUNICATIONS, INC.'S COMPLIANCE WITH SECTION 271 OF THE TELECOMMUNICATIONS ACT OF 1996

Docket No. T-00000D-00-0672: IN THE MATTER OF INVESTIGATION OF THE COST OF TELECOMMUNICATIONS ACCESS

California

APPLICATION A.05-05-027: APPLICATION BY PACIFIC BELL TELEPHONE COMPANY D/B/A SBC CALIFORNIA (U 1001 C) FOR ARBITRATION OF AN INTERCONNECTION AGREEMENT WITH MCIMETRO ACCESS TRANSMISSION SERVICES LLC (U 5253 C) PURSUANT TO SECTION 252(B) OF THE TELECOMMUNICATIONS ACT OF 1996.

APPLICATION 01-01-010: APPLICATION BY PACIFIC BELL TELEPHONE COMPANY (U 1001 C) FOR ARBITRATION OF AN INTERCONNECTION AGREEMENT WITH MCIMETRO ACCESS TRANSMISSION SERVICES, L.L.C. (U 5253 C) PURSUANT TO SECTION 252(B) OF THE TELECOMMUNICATIONS ACT OF 1996

RULEMAKING R.93-04-003, INVESTIGATION I.93-04-002: ON THE COMMISSION'S OWN MOTION TO GOVERN OPEN ACCESS TO BOTTLENECK SERVICES AND ESTABLISH A FRAMEWORK FOR NETWORK ARCHITECTURE DEVELOPMENT OF DOMINANT CARRIER NETWORKS; INVESTIGATION ON THE COMMISSION'S OWN MOTION INTO OPEN ACCESS AND NETWORK ARCHITECTURE DEVELOPMENT OF DOMINANT CARRIER NETWORKS

Colorado

Docket No. 02A-538T: IN THE MATTER OF THE JOINT APPLICATION FOR APPROVAL OF A PLAN TO RESTRUCTURE REGULATED INTRASTATE SWITCHED ACCESS RATES AND PETITION FOR A DECLARATORY ORDER

Docket Nos. 04A-411T & 04D-440T: IN THE MATTER OF THE COMBINED APPLICATION OF QWEST CORPORATION FOR RECLASSIFICATION AND DEREGULATION OF CERTAIN PART 2 PRODUCTS AND SERVICES AND DEREGULATION OF CERTAIN PART 3 PRODUCTS AND SERVICES; and STAFF OF THE COLORADO PUBLIC UTILITIES COMMISSION'S PETITION FOR A DECLARATORY ORDER CONCERNING THE RECLASSIFICATION AND DEREGULATION OF TELECOMMUNICATIONS SERVICES UNDER PARTS 2 AND 3, TITLE 40, ARTICLE 15 OF THE COLORADO REVISED STATUTES

Florida

Docket No. 941272-TL: IN RE: SOUTHERN BELL TELEPHONE AND TELEGRAPH COMPANY'S PETITION FOR APPROVAL OF NUMBERING PLAN AREA RELIEF FOR 305 AREA CODE

Docket No.950696-TP: IN RE: DETERMINATION OF FUNDING FOR UNIVERSAL SERVICE AND CARRIER OF LAST RESORT RESPONSIBILITIES.

Docket No. 950737-TP: IN RE: INVESTIGATION INTO TEMPORARY LOCAL TELEPHONE NUMBER PORTABILITY SOLUTION TO IMPLEMENT COMPETITION IN LOCAL EXCHANGE TELEPHONE MARKETS.

Docket No. 950984-TP: IN RE: RESOLUTION OF PETITION(S) TO ESTABLISH NON-DISCRIMINATORY RATES, TERMS, AND CONDITIONS FOR RESALE INVOLVING LOCAL EXCHANGE COMPANIES AND ALTERNATIVE LOCAL EXCHANGE COMPANIES PURSUANT TO SECTION 364.162, FLORIDA STATUTES.

Docket No. 950985-TP: IN RE: RESOLUTION OF PETITION(S) TO ESTABLISH NON-DISCRIMINATORY RATES, TERMS, AND CONDITIONS FOR INTERCONNECTION INVOLVING LOCAL EXCHANGE COMPANIES AND ALTERNATIVE LOCAL EXCHANGE COMPANIES PURSUANT TO SECTION 364.162, FLORIDA STATUTES.

Docket No. 000649-TP: IN RE: PETITION OF MCIMETRO ACCESS TRANSMISSION SERVICES, LLC AND MCI WORLDCOM COMMUNICATIONS, INC. FOR ARBITRATION OF CERTAIN TERMS AND CONDITIONS OF PROPOSED AGREEMENT WITH BELL SOUTH TELECOMMUNICATIONS, INC. CONCERNING INTERCONNECTION AND RESALE UNDER THE TELECOMMUNICATIONS ACT OF 1996.

Georgia

Docket No. 5548-U: IN RE: INVESTIGATION INTO THE FUNDING OF UNIVERSAL SERVICE.

Docket No. 6537-U: IN THE MATTER OF: MCIMETRO PETITION TO ESTABLISH NONDISCRIMINATORY RATES, TERMS AND CONDITIONS FOR UNBUNDLING AND RESALE OF LOCAL LOOPS.

Docket No. 11901-U: IN RE: PETITION OF MCIMETRO ACCESS TRANSMISSION SERVICES, LLC AND MCI WORLDCOM COMMUNICATIONS, INC. FOR ARBITRATION OF CERTAIN TERMS AND CONDITIONS OF PROPOSED AGREEMENT WITH BELLSOUTH TELECOMMUNICATIONS, INC. CONCERNING INTERCONNECTION AND RESALE UNDER THE TELECOMMUNICATIONS ACT OF 1996.

Illinois

Docket No. 04-0469: PETITION FOR ARBITRATION OF INTERCONNECTION RATES, TERMS AND CONDITIONS AND RELATED ARRANGEMENTS WITH ILLINOIS BELL TELEPHONE COMPANY PURSUANT TO SECTION 252(b) OF THE TELECOMMUNICATIONS ACT OF 1996.

Kansas

Docket No. 190,492-U: IN THE MATTER OF A GENERAL INVESTIGATION INTO COMPETITION WITHIN THE TELECOMMUNICATIONS INDUSTRY IN THE STATE OF KANSAS

Docket No. 02-GIMT-678-GIT: IN THE MATTER OF A GENERAL INVESTIGATION INTO WINBACK/RETENTION PROMOTIONS AND PRACTICES

Louisiana

Docket No. U-17957: IN RE: INVESTIGATION OF OPERATING PRACTICES OF ALTERNATIVE OPERATOR SERVICES PROVIDERS TO INCLUDE RATES AND CHARGES.

Docket No. U-19806: IN RE: PETITION OF AT&T COMMUNICATIONS OF THE SOUTH CENTRAL STATES, INC., FOR REDUCED REGULATION OF INTRASTATE OPERATIONS.

Docket No. U-20237: IN RE: OBJECTIONS TO THE FILING OF REDUCED WATS SAVER SERVICE RATES, INTRALATA, STATE OF LOUISIANA.

Docket No. U-20710: IN RE: GENERIC HEARING TO CLARIFY THE PRICING/IMPUTATION STANDARD SET FORTH IN COMMISSION ORDER NO. U- 17949-N ON A PROSPECTIVE BASIS ONLY, AS THE STANDARD RELATES TO LEC COMPETITIVE TOLL OFFERINGS.

Docket No. U-20883: IN RE: THE DEVELOPMENT OF RULES AND REGULATIONS APPLICABLE TO THE ENTRY AND OPERATIONS OF, AND THE PROVIDING OF SERVICES BY, COMPETITIVE AND ALTERNATE ACCESS PROVIDERS IN THE LOCAL, INTRASTATE AND/OR INTEREXCHANGE TELECOMMUNICATIONS MARKET IN LOUISIANA. SUBDOCKET A: UNIVERSAL SERVICE.

Docket No. U-25350: IN RE: PETITION OF MCIMETRO ACCESS TRANSMISSION SERVICES, LLC FOR ARBITRATION OF CERTAIN TERMS AND CONDITIONS OF PROPOSED AGREEMENT WITH BELL SOUTH TELECOMMUNICATIONS, INC. CONCERNING INTERCONNECTION AND RESALE UNDER THE TELECOMMUNICATIONS ACT OF 1996.

Minnesota

Docket No. P-421/CI-01-1371: IN THE MATTER OF A COMMISSION INVESTIGATION INTO QWEST'S COMPLIANCE WITH SECTION 271(c)(2)(B) OF THE TELECOMMUNICATIONS ACT OF 1996; CHECKLIST ITEMS 1, 2, 4, 5, 6, 11, 13, AND 14

Missouri

Case No. TO-87-42: IN THE MATTER OF SOUTHWESTERN BELL TELEPHONE COMPANY FILING ACCESS SERVICES TARIFF REVISIONS AND WIDE AREA TELECOMMUNICATIONS SERVICE (WATS) TARIFF, INDEX, 6th REVISED SHEET, ORIGINAL SHEET 16.01.

Case No. TO-95-289, ET AL: IN THE MATTER OF AN INVESTIGATION INTO THE EXHAUSTION OF TELEPHONE NUMBERS IN THE 314 NUMBERING PLAN AREA.

CASE NO. TC-2000-225, ET AL.: MCI WORLDCOM COMMUNICATIONS, INC., BROOKS FIBER COMMUNICATIONS OF MISSOURI, INC., BROADSPAN COMMUNICATIONS, INC., D/B/A PRIMARY NETWORK COMMUNICATIONS, INC., COMPLAINANTS, VS. SOUTHWESTERN BELL TELEPHONE COMPANY, RESPONDENT.

CASE NO. TO-2001-467: IN THE MATTER OF THE INVESTIGATION OF THE STATE OF COMPETITION IN THE EXCHANGES OF SOUTHWESTERN BELL TELEPHONE COMPANY.

CASE No. TO-2002-222: PETITION OF MCImetro ACCESS TRANSMISSION SERVICES LLC, BROOKS FIBER COMMUNICATIONS OF MISSOURI, INC. AND MCI WORLDCOM COMMUNICATIONS, INC. FOR ARBITRATION OF AN INTERCONNECTION AGREEMENT WITH SOUTHWESTERN BELL TELEPHONE COMPANY UNDER THE TELECOMMUNICATIONS ACT OF 1996

CASE Nos. TT-2002-472 and TT-2002-473: IN THE MATTER OF SOUTHWESTERN BELL TELEPHONE COMPANY'S TARIFF FILING TO INITIATE RESIDENTIAL CUSTOMER WINBACK PROMOTION; AND IN THE MATTER OF SOUTHWESTERN BELL TELEPHONE COMPANY'S TARIFF FILING TO EXTEND BUSINESS CUSTOMER WINBACK PROMOTIONS

CASE No. TO-2005-0336: SOUTHWESTERN BELL TELEPHONE, L.P. d/b/a SBC MISSOURI'S PETITION FOR COMPULSORY ARBITRATION OF UNRESOLVED ISSUES FOR A SUCCESSOR INTERCONNECTION AGREEMENT TO THE MISSOURI 271 AGREEMENT ("M2A")

Nevada

CASE NO. 01-12047: IN RE: APPLICATION OF CENTRAL TELEPHONE COMPANY - NEVADA d/b/a SPRINT OF NEVADA TO CONTINUE PARTICIPATION IN THE PLAN OF ALTERNATIVE REGULATION, INCLUDING A REQUEST TO INCREASE PRICES

DOCKET NO. 01-12047: IN RE APPLICATION OF CENTRAL TELEPHONE COMPANY - NEVADA D/B/A SPRINT OF NEVADA TO CONTINUE PARTICIPATION IN THE PLAN OF ALTERNATIVE REGULATION, INCLUDING A REQUEST TO INCREASE PRICES.

New Jersey

Docket No. TO01020095: IN THE MATTER OF THE APPLICATION OF VERIZON NEW JERSEY, INC. FOR APPROVAL (I) OF A NEW PLAN FOR AN ALTERNATIVE FORM OF REGULATION AND (II) TO RECLASSIFY MULTI-LINE RATE REGULATED BUSINESS SERVICES AS COMPETITIVE SERVICES, AND COMPLIANCE FILING

North Carolina

Docket No. P-100, SUB 119: IN THE MATTER OF: ASSIGNMENT OF N11 DIALING CODES.

Docket No. P-141, SUB 29: IN THE MATTER OF: PETITION OF MCI TELECOMMUNICATIONS CORPORATION FOR ARBITRATION OF INTERCONNECTION WITH BELLSOUTH TELECOMMUNICATIONS, INC.

Docket No. P-474, SUB 10: IN RE: PETITION OF MCIMETRO ACCESS TRANSMISSION SERVICES, LLC FOR ARBITRATION OF CERTAIN TERMS AND CONDITIONS OF PROPOSED AGREEMENT WITH BELL SOUTH TELECOMMUNICATIONS, INC. CONCERNING INTERCONNECTION AND RESALE UNDER THE TELECOMMUNICATIONS ACT OF 1996.

Ohio

Docket No. 01-1319-TP-ARB: IN THE MATTER OF MCIMETRO ACCESS TRANSMISSION SERVICES, LLC PETITION FOR ARBITRATION PURSUANT TO SECTION 252(b) OF THE TELECOMMUNICATIONS ACT OF 1996 TO ESTABLISH AN INTERCONNECTION AGREEMENT WITH AMERITECH OHIO.

Oklahoma

Consolidated Dockets PUD NO. 000237: IN THE MATTER OF THE APPLICATION OF SOUTHWESTERN BELL TELEPHONE COMPANY FOR AN ORDER APPROVING PROPOSED CHANGES AND ADDITIONS IN APPLICANTS' WIDE AREA TELECOMMUNICATIONS SERVICE PLAN TARIFF; and,
PUD NO. 000254: IN THE MATTER OF THE APPLICATION OF SOUTHWESTERN BELL TELEPHONE COMPANY FOR AN ORDER APPROVING PROPOSED ADDITIONS AND CHANGES IN APPLICANTS' ACCESS SERVICE TARIFF AND WIDE AREA TELECOMMUNICATIONS SERVICE PLAN TARIFF

Consolidated Dockets PUD NO.920001335: IN THE MATTER OF THE APPLICATION OF THE OKLAHOMA RURAL TELEPHONE COALITION, GTE SOUTHWEST, INC., ALLTEL OKLAHOMA, INC., AND OKLAHOMA ALLTEL, INC. FOR AN ORDER ADOPTING THE OKLAHOMA ALTERNATIVE SETTLEMENT PLAN; and
PUD NO.920001213: IN THE MATTER OF THE APPLICATION OF SOUTHWESTERN BELL TELEPHONE COMPANY FOR AN ORDER IMPLEMENTING TERMINATING ACCESS CHARGES IN LIEU OF INTRALATA TOLL AND SURCHARGE POOLS; and
PUD NO.940000051: IN RE: INQUIRY OF THE OKLAHOMA CORPORATION COMMISSION REGARDING WHETHER THE INTRALATA TOLL POOL AND SURCHARGE POOL SHOULD CONTINUE TO EXIST IN THE STATE OF OKLAHOMA

Oregon

Docket UN 1038: IN THE MATTER OF AN INVESTIGATION INTO ISSUES RELATED TO THE COMMISSION POLICY OF POSTING SERVICE QUALITY REPORTS TO ITS WEBSITE, PURSUANT TO ORS 756.510

South Carolina

Docket No. 92-606-C: IN RE: N11 SERVICE CODES.

Tennessee

Docket No.93-07799: IN RE: SHOW CAUSE PROCEEDING AGAINST CERTIFIED IXCS AND LECS TO PROVIDE TOLL FREE, COUNTY-WIDE CALLING.

Docket No.93-08793: IN RE: APPLICATION OF MCI METRO ACCESS TRANSMISSION SERVICES, INC. FOR AUTHORITY TO OFFER LOCAL EXCHANGE SERVICES WITHIN TENNESSEE.

Docket No.94-00184: INQUIRY FOR TELECOMMUNICATIONS RULEMAKING REGARDING COMPETITION IN THE LOCAL EXCHANGE.

Docket No.95-02499: UNIVERSAL SERVICE PROCEEDING, PART 1 - COST OF UNIVERSAL SERVICE AND CURRENT SOURCES OF UNIVERSAL SERVICE SUPPORT, AND PART 2 - ALTERNATIVE UNIVERSAL SERVICE SUPPORT MECHANISMS.

Docket No. 00-00309: PETITION OF MCIMETRO ACCESS SERVICES, LLC AND BROOKS FIBER COMMUNICATIONS OF TENNESSEE, INC. FOR ARBITRATION UNDER THE TELECOMMUNICATIONS ACT OF 1996

Texas

Docket 4992: APPLICATION OF GENERAL TELEPHONE COMPANY OF THE SOUTHWEST FOR A RATE/TARIFF REVISION.

Docket 5113: PETITION OF PUBLIC UTILITY COMMISSION FOR AN INQUIRY CONCERNING THE EFFECTS OF THE MODIFIED FINAL JUDGMENT AND THE ACCESS CHARGE ORDER UPON SW BELL AND THE INDEPENDENT TELEPHONE COMPANIES OF TEXAS (Phase II).

Docket 5610: APPLICATION OF GENERAL TELEPHONE COMPANY OF THE SOUTHWEST FOR A RATE INCREASE.

Docket 5800: APPLICATION OF AT&T COMMUNICATIONS FOR AUTHORITY TO IMPLEMENT "REACH OUT TEXAS."

Docket 5898; APPLICATION OF SAN ANGELO FOR REMOVAL OF THE EXTENDED AREA SERVICE CHARGE FROM GENERAL TELEPHONE COMPANY OF THE SOUTHWEST'S RATES IN SAN ANGELO, TEXAS.

Docket 5926: APPLICATION OF SOUTHWESTERN BELL TELEPHONE COMPANY TO ESTABLISH FEATURE GROUP "E" (FGE) ACCESS SERVICE FOR RADIO AND CELLULAR COMMON CARRIERS.

Docket 5954: INQUIRY OF THE PUBLIC UTILITY COMMISSION OF TEXAS INTO OFFERING EXTENDED AREA SERVICE IN THE CITY OF ROCKWALL.

- Docket 6095: APPLICATION OF AT&T COMMUNICATION FOR A RATE INCREASE.
- Docket 6200: PETITION OF SOUTHWESTERN BELL TELEPHONE COMPANY FOR AUTHORITY TO CHANGE RATES.
- Docket 6264: PETITION OF THE GENERAL COUNSEL FOR INITIATION OF AN EVIDENTIARY PROCEEDING TO ESTABLISH TELECOMMUNICATIONS SUBMARKETS.
- Docket 6501: APPLICATION OF VALLEY VIEW TELEPHONE COMPANY FOR AN AMENDMENT TO CERTIFICATE OF CONVENIENCE AND NECESSITY.
- Docket 6635: APPLICATION OF MUSTANG TELEPHONE COMPANY FOR AUTHORITY TO CHANGE RATES.
- Docket 6740: APPLICATION OF SOUTHWEST TEXAS TELEPHONE COMPANY FOR RATE INCREASE.
- Docket 6935: APPLICATION OF SOUTHWESTERN BELL TELEPHONE COMPANY TO INTRODUCE MICROLINK II- PACKET SWITCHING DIGITAL SERVICE.
- Docket 8730: INQUIRY OF THE GENERAL COUNSEL INTO THE MEET-POINT BILLING PRACTICES OF GTE SOUTHWEST, INC.
- Docket 8218: INQUIRY OF THE GENERAL COUNSEL INTO THE WATS PRORATE CREDIT.
- Docket 8585: INQUIRY OF THE GENERAL COUNSEL INTO THE REASONABLENESS OF THE RATES AND SERVICES OF SOUTHWESTERN BELL TELEPHONE COMPANY.
- Docket 10127: APPLICATION OF SOUTHWESTERN BELL TELEPHONE COMPANY TO REVISE SECTION 2 OF ITS INTRASTATE ACCESS SERVICE TARIFF.
- Docket 11441: PETITIONS OF INFODIAL, INC., AND OTHERS FOR ASSIGNMENT OF ABBREVIATED N11 DIALING CODES.
- Docket 11840: JOINT PETITION OF SOUTHWESTERN BELL TELEPHONE COMPANY AND GTE SOUTHWEST, INC. TO PROVIDE EXTENDED AREA SERVICE TO CERTAIN COMMUNITIES IN THE LOWER RIO GRANDE VALLEY.
- Docket 14447: PETITION OF MCI TELECOMMUNICATIONS CORPORATION FOR AN INVESTIGATION OF THE PRACTICES OF SOUTHWESTERN BELL TELEPHONE COMPANY REGARDING THE EXHAUSTION OF TELEPHONE NUMBERS IN THE 214 NUMBERING PLAN AREA AND REQUEST FOR A CEASE AND DESIST ORDER AGAINST SOUTHWESTERN BELL TELEPHONE COMPANY.

Dockets 14940 and 14943: APPLICATION OF SOUTHWESTERN BELL TELEPHONE COMPANY FOR INTERIM NUMBER PORTABILITY PURSUANT TO §3.455 OF THE PUBLIC UTILITY REGULATORY ACT; AND APPLICATION OF GTE SOUTHWEST, INC. AND CONTEL OF TEXAS, INC. FOR INTERIM NUMBER PORTABILITY PURSUANT TO §3.455 OF THE PUBLIC UTILITY REGULATORY ACT.

Docket 16251: INVESTIGATION OF SOUTHWESTERN BELL TELEPHONE COMPANY'S ENTRY INTO THE INTERLATA TELECOMMUNICATIONS MARKET.

Docket 16285: PETITION OF MCI TELECOMMUNICATIONS CORPORATION AND ITS AFFILIATE MCIMETRO ACCESS TRANSMISSION SERVICES, INC. FOR ARBITRATION AND REQUEST FOR MEDIATION UNDER THE FEDERAL TELECOMMUNICATIONS ACT OF 1996.

Docket 18117: COMPLAINT OF MCI TELECOMMUNICATIONS CORPORATION AND MCIMETRO ACCESS TRANSMISSION SERVICE, INC. AGAINST SWBT FOR VIOLATION OF COMMISSION ORDER IN DOCKET NOS. 16285 AND 17587 REGARDING PROVISIONING OF UNBUNDLED DEDICATED TRANSPORT.

Docket 19075: PETITION OF MCI TELECOMMUNICATIONS CORPORATION FOR ARBITRATION OF DIRECTORY ASSISTANCE LISTINGS ISSUES UNDER FEDERAL TELECOMMUNICATIONS ACT OF 1996.

Docket 21706: COMPLAINT OF MFS COMMUNICATIONS COMPANY, INC. AGAINST GTE SOUTHWEST, INCORPORATED REGARDING GTE'S NONPAYMENT OF RECIPROCAL COMPENSATION

Docket 21791: PETITION OF SOUTHWESTERN BELL TELEPHONE COMPANY FOR ARBITRATION WITH MCI WORLDCOM COMMUNICATIONS, INC. PURSUANT TO SECTION 252(B)(1) OF THE FEDERAL TELECOMMUNICATIONS ACT OF 1996.

Docket 21982: PROCEEDING TO EXAMINE RECIPROCAL COMPENSATION PURSUANT TO SECTION 252 OF THE FEDERAL TELECOMMUNICATIONS ACT OF 1996.

Dockets 22168/22469: PETITION OF IP COMMUNICATIONS CORPORATION TO ESTABLISH EXPEDITED PUBLIC UTILITY COMMISSION OF TEXAS OVERSIGHT CONCERNING LINE SHARING ISSUES; COMPLAINT OF COVAD COMMUNICATIONS COMPANY AND RHYTHMS LINKS, INC. AGAINST SOUTHWESTERN BELL TELEPHONE COMPANY AND GTE SOUTHWEST INC. FOR POST-INTERCONNECTION AGREEMENT DISPUTE RESOLUTION AND ARBITRATION UNDER THE TELECOMMUNICATIONS ACT OF 1996 REGARDING RATES, TERMS, CONDITIONS AND RELATED ARRANGEMENTS FOR LINE SHARING

Docket 24542: PETITION OF MCIMETRO ACCESS TRANSMISSION SERVICES LLC FOR ARBITRATION OF AN INTERCONNECTION AGREEMENT WITH SOUTHWESTERN BELL TELEPHONE COMPANY UNDER THE TELECOMMUNICATIONS ACT OF 1996

DOCKET 28821: ARBITRATION OF NON-COSTING ISSUES FOR SUCCESSOR INTERCONNECTION AGREEMENTS TO THE TEXAS 271 AGREEMENT

Washington

Docket No. UT-003022: IN THE MATTER OF THE INVESTIGATION INTO U S WEST COMMUNICATIONS, INC.'S COMPLIANCE WITH SECTION 271 OF THE TELECOMMUNICATIONS ACT OF 1996

DOCKET NO. UT-003013, Part D: IN THE MATTER OF THE CONTINUED COSTING AND PRICING OF UNBUNDLED NETWORK ELEMENTS, TRANSPORT, AND TERMINATION