



Suite 1200  
106 East College Avenue  
Tallahassee, FL 32301  
www.akerman.com  
850 224 9634 tel 850 222 0103 fax

Dallas  
Denver  
Fort Lauderdale  
Jacksonville  
Las Vegas  
Los Angeles  
Madison  
Miami  
New York  
Orlando  
Tallahassee  
Tampa  
Tysons Corner  
Washington, DC  
West Palm Beach

RECEIVED-PPSC  
10 MAY 28 PM 3:32  
COMMISSION  
CLERK

May 28, 2010

**VIA HAND DELIVERY**

Ms. Ann Cole  
Commission Clerk  
Florida Public Service Commission  
2540 Shumard Oak Boulevard  
Tallahassee, FL 32399-0850

**Docket No. 100264-EI: Review Of 2010 Electric Infrastructure Storm Hardening Plan filed pursuant to Rule 25-6.0342, Florida Administrative Code, submitted by Florida Public Utilities Company**

Dear Ms. Cole:

Enclosed for filing, please find the original and 7 copies of Florida Public Utilities Company's Petition for Approval of **Amended** Updated Storm Hardening Plan, along with its 2010-2012 Storm Hardening Plan, submitted in accordance with Rule 25-6.0342, Florida Administrative Code.

Please kindly confirm receipt by stamping the enclosed extra copy of this cover letter and

COM \_\_\_\_\_  
APA \_\_\_\_\_  
ECR 6  
GCL 1  
RAB \_\_\_\_\_  
SSC \_\_\_\_\_  
ADP \_\_\_\_\_  
OPC \_\_\_\_\_  
CLK \_\_\_\_\_

{TL227599;1}

DOCUMENT NUMBER-DATE  
04494 MAY 28 0  
FPSC-COMMISSION CLERK

Ms. Ann Cole  
May 28, 2010  
Page 2

---

returning it to me. Thank you for your assistance with this filing. As always, if you have any questions whatsoever about this filing, please do not hesitate to contact me.

Sincerely,

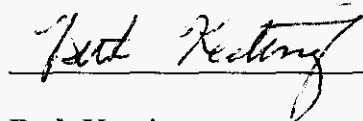

---

**Beth Keating**  
**AKERMAN SENTERFITT**  
106 East College Avenue, Suite 1200  
Tallahassee, FL 32302-1877  
Phone: (850) 224-9634  
Fax: (850) 222-0103

Enclosures

cc: Office of Public Counsel

**BEFORE THE FLORIDA PUBLIC SERVICE COMMISSION**

In Re: Petition of Florida Public Utilities )  
Company for approval of its 2010 Storm Hardening ) Docket No. 100264-EI  
Plan. ) Filed: May 28, 2010  
\_\_\_\_\_ )

**PETITION OF FLORIDA PUBLIC UTILITIES COMPANY FOR APPROVAL OF  
AMENDED UPDATED STORM HARDENING PLAN**

Florida Public Utilities Company ("FPUC" or "Company"), pursuant to Rule 25-6.0342(2), Florida Administrative Code, and Order No. PSC-08-0327-FOF-EI, hereby files its updated Storm Hardening Plan and petitions the Florida Public Service Commission (PSC) to approve the Company's amended, updated 2010-2012 Storm Hardening Plan. This filing is made to provide the Commission with the Company's amended 2010-2012 Storm Hardening Plan, which includes additional updates and detail as suggested in the Company's May 3, 2010 Petition in this Docket.

In support of this Petition, FPUC states:

1. The Company is a utility with its principal office located at:

Florida Public Utilities Company  
401 South Dixie Highway  
West Palm Beach, FL 33401

2. The name and mailing address of the persons authorized to receive notices are:

Beth Keating  
Akerman Senterfitt  
106 East College Avenue  
Suite 1200  
Tallahassee, Florida 32301

Mr. P. Mark Cutshaw  
Florida Public Utilities Company  
P.O. Box 418  
Fernandina Beach, FL  
32035-0418

3. Rule 25-6.0342(2), Florida Administrative Code, provides as follows:

(2) Storm Hardening Plans. Each utility shall, no later than 90 days after the effective date of this rule, file with the Commission for its approval a detailed storm hardening plan. Each utility's plan shall be updated every 3

years, unless the Commission, on its own motion or on petition by a substantially affected person or utility, initiates a proceeding to review and, if appropriate, modify the plans. In a proceeding to approve a utility's plan, the Commission shall consider whether the utility's plan meets the desired objectives of enhancing reliability and reducing restoration costs and outage times in a prudent, practical, and cost-effective manner to the affected parties.

4. Attached hereto as Exhibit 1, is FPUC's 2010-2012 Storm Hardening Plan and storm hardening specifications. As noted in the Company's May 3 filing, FPUC also continues to conform with the "Process to Engage," as well as the stipulation between FPUC and the Florida Cable Telecommunications Association, which were entered into, and approved, in Docket No. 070300-EI. These agreements were attached to FPUC's May 3 filing.

5. FPUC's updated 2010-2012 Plan will provide significant storm resilience benefits, in a cost-effective manner, consistent with the requirements of Rule 25-6.0342, Florida Administrative Code.

WHEREFORE, Florida Public Utilities Company hereby respectfully asks that the Commission accept the Company's amended 2010-2012 Storm Hardening Plan and, upon review, make a determination that FPUC's 2010-2012 Storm Hardening Plan complies with Rule 25-6.0342, Florida Administrative Code.

RESPECTFULLY SUBMITTED this 28th day of May, 2010.

  
Beth Keating  
Akerman Senterfitt Attorneys at Law  
106 East College Avenue, Suite 1200  
Tallahassee, FL 32301  
(850) 224-9634

*Attorneys for Florida Public Utilities Company*

FLORIDA PUBLIC UTILITIES COMPANY  
2010 – 2012 STORM HARDENING PLAN

**EXHIBIT 1**

2010-2012  
UPDATED STORM HARDENING PLAN AND SPECIFICATIONS



# Florida Public Utilities Company

Storm Hardening Plan  
2010 - 2012

Rule 25-6.0342 F.A.C.

May 2010

# Table of Contents

## Introduction

- 1.0 Wood Pole Inspection Plan
- 2.0 Ten Part Storm Preparedness Plan
  - 2.1 Vegetation Management
  - 2.2 Joint Use Pole Attachment Audits
  - 2.3 Inspection Cycle of Transmission Structures
  - 2.4 Storm Hardening Activities for Transmission Structures
  - 2.5 Geographic Information System (GIS)
  - 2.6 Post Storm Data Collection and Forensics Analysis
  - 2.7 Outage Data for Overhead and Underground Systems
  - 2.8 Coordination with Local Governments
  - 2.9 Collaborative Research
  - 2.10 Disaster Prepared and Recovery Plans
- 3.0 Compliance with NESC Overhead Requirements
  - 3.1 Distribution
  - 3.2 Transmission
  - 3.3 Substation
  - 3.4 Extreme Wind Loading for Distribution Facilities
- 4.0 Mitigation of Damage Due to Storm Surge and Flooding
- 5.0 Placement of New and Replacement Facilities
- 6.0 Deployment Strategy
  - 6.1 Description of Facilities Affected
  - 6.2 Communities and Areas Affected by Electric Infrastructure Improvements
  - 6.3 Upgrading of Joint Use Facilities
  - 6.4 Estimated Cost and Benefits
- 7.0 Joint Use Impacts
  - 7.1 Wood Pole Inspections
  - 7.2 Joint Use Audits
  - 7.3 Attachment Standards and Procedures
  - 7.4 Soliciting Input from Third Party Attachments
  - 7.5 Estimates of Cost and Benefits from Third Party Attachments
- Attachments Joint Use Attachment Specifications
- Appendix A Osmose Inspection Groundline Decay by Age Group Composite – CCA Poles Only/ 2008-2009 Distribution Poles

# FLORIDA PUBLIC UTILITIES COMPANY

## COMPLIANCE WITH FLORIDA PUBLIC SERVICE COMMISSION REQUIREMENT FOR INVESTOR OWNED ELECTRIC UTILITIES TO ADDRESS ONGOING STORM HARDENING PLANS, CONSTRUCTION STANDARDS AND IMPLEMENTATION COST ESTIMATES

### INTRODUCTION

This filing is to fulfill the Requirement for Investor Owned Electric Utilities to File Ongoing Storm Hardening Plans and Implementation Cost Estimates as set forth in Rule 25-6.0342(2), Florida Administrative Code, FPSC Order PSC-07-0043A-FOF-EU, and Order No. PSC-08-0327-FOF-EI.

FPUC is currently in the process of developing a specification manual that will take into consideration all the plans shown below. Based on this, some of the information requested has not yet been developed but will be provided to all interested parties upon completion.

#### **1.0 Wood Pole Inspection Plan**

In 2008, Florida Public Utilities Company (FPUC) implemented an eight year inspection cycle program for all wooden transmission and distribution poles. The current edition of the National Electric Safety Code (NESC) is used as the basis for pole inspections. The results of these inspections are reported to the FPSC in the FPUC annual distribution reliability report.

FPUC performs inspections of all wooden transmission and distribution poles in accordance with the predetermined cycles. Cycles have been established, for each FPUC division, based on a logical and efficient method for inspecting poles. The cycles may fluctuate year to year based on unforeseen factors but FPUC will ensure that all poles are inspected at least once every eight years.

During 2008 and 2009 cycle inspections, FPUC used an industry recognized pole inspection and treatment contractor to collect two years of data for all CCA poles inspected for FPUC. The data was used to evaluate the need to do a complete visual, sound and bore, and excavation inspection on newer chromated copper arsenate (CCA) poles. Inspection data was collected and consolidated for both FPUC electric divisions. Two thousand six hundred and twenty five (2,625) CCA poles were inspected during this two year inspection period. CCA pole ages ranged from one year to 28 years old. None of the poles inspected failed inspection. A summary table of inspection results was prepared by the inspection contractor and is attached (see Appendix A). Based upon this conclusive data, and to be consistent with inspection criteria for CCA pole inspections performed by other investor owned utility companies in Florida, FPUC proposes to visually inspect, sound, and selectively bore (if internal decay is suspected) all CCA poles under 16 years of age. Unless a pole fails sound and bore, a full excavation will not be performed on these poles. In order to ensure that more rigorous inspections are not warranted, FPUC will augment its annual pole inspection program to include full excavation sampling of approximately



1.0% of CCA poles planned for current cycle inspection that would not normally qualify for full excavation. The sampling results will be filed in the FPUC annual distribution reliability report.

### Inspection Process

The typical inspection consists of a visual inspection to determine if any defects are found that would require that the pole be replaced. Should this inspection indicate that the pole is not suited for continued use, it will be rejected and the appropriate corrective action (replacement, bracing, etc.) will be planned.

If the pole is found acceptable on the visual inspection, except certain CCA poles previously discussed, the pole will be sound and bored to determine the internal condition of the pole. Should this test indicate that the pole is not suited for continued use, it will be rejected and the appropriate corrective action (replacement, bracing, etc.) will be planned.

If the pole is found acceptable in the sound and bore test, all poles, except certain CCA poles previously discussed, will be excavated and tested. If this test indicates the pole is suitable for continued service, the pole will be treated and backfilled. Should this test indicate that the pole is not suited for continued use, it will be rejected and the appropriate corrective action (replacement, bracing, etc) will be planned. Methods are available from Contractors that will allow below ground inspection of poles in concrete or asphalt areas. These methods will be utilized to inspect in accordance with procedures above.

FPUC will perform both strength and loading assessments on each pole inspected should the above mentioned test indicate that the pole is suitable for continued use.

### Strength and Loading Assessment

The Strength Assessment will compare the current measured circumference to the original circumference of the pole. The effective circumference of the pole will be determined to ensure that the current condition of the pole meets the requirements in Table 261-1A of the NESC. Should this test indicate that the pole is not suited for continued use, it will be rejected and the appropriate corrective action (replacement, bracing, etc.) will be planned.

The Loading Assessment will consider actual attachments on the pole. In performing this test, field measurements, span lengths, attachment heights, wire sizes and other attachments (including 3<sup>rd</sup> party attachments) will be analyzed in order to determine if current FPUC specifications are met and if this application meets NESC requirements. Should this test indicate that the pole is not suited for continued use, it will be rejected and the appropriate corrective action (replacement, bracing, etc.) will be planned.

Should poles be encountered that are of the same size, condition and construction, sampling will be conducted in order to ensure the strength and loading characteristics are sufficient.

FPUC will collect all relevant information on the pole inspections on an annual basis for all FPUC owned poles. Information will be maintained in a spreadsheet format by location, pole size, pole class, test results, etc. and be in such a form that summary information can be developed. Poles owned by other companies will be inspected in accordance with their specific procedures and FPUC will cooperate with any work caused by pole replacements. FPUC will

work closely with 3<sup>rd</sup> party owners to share information on all poles in order to ensure work is completed in a timely manner.

In order to ensure the integrity of the pole inspection procedure, the contractor will be required to perform quality control assessments of work in order to ensure pole inspection requirements are being met and provide documentation that this has occurred. FPUC will also random sample the results presented in order to verify and document results.

FPUC will submit a summary report, as required, to the Florida Public Service Commission by March 1 of each year outlining results of the previous year's inspection. The summary will include type of inspection, poles inspected, pole data, poles rejected, reasons for rejection, and poles replaced or braced. This information will be analyzed on a continuing basis to determine trends associated with pole replacements in order to improve the overall inspection program.

The estimated annual cost to perform pole inspections is \$152,000. It is estimated that 3800 poles will be inspected each year. The anticipated pole failure rate based on recent performance is 10%. Therefore, approximately 380 poles will require replacement. The associated cost to replace or brace the poles will be approximately \$513,000 per year.

## **2.0 Ten Part Storm Preparedness Plan**

### **2.1 Vegetation Management**

FPUC is currently working towards the accomplishment of a three year vegetation management cycle on main feeders effective beginning in June 2008. The plan also includes a six year vegetation management cycle on laterals on the system. Although data was not readily available for the FPUC system, other companies with the necessary data have justified this increased trim cycle based on that data.

The program will include the following:

1. Three year vegetation management cycle on all main feeders.
2. Six year vegetation management cycle on all laterals.
3. Increased participation with local governments to address vegetation management and alternatives in order to improve overall reliability due to tree related outages.
4. Information will be made available to customers regarding the maintenance and placement of trees.

Based upon the current tree trimming crew level, the Company will work make reasonable efforts to address the following items if and when tree trimming crews become available.

1. Annual inspection of main feeders to critical infrastructure prior to the storm season to identify and perform the necessary trimming.
2. Address danger trees located outside the normal trim zone and located near main feeders as reported.

Based on 2007 information, as shown below, the total system to be maintained in the vegetation management program involves 723 miles of distribution lines and 21.5 miles of transmission lines. The distribution lines are made up of 147 miles of main feeders and 576 miles of laterals. Below is an analysis of the resources necessary to achieve the desired results to complete a three year main feeder and six year lateral cycle. The overall year to date average for 2007 is 36 miles per year per crew in Northwest Florida and 17 miles per year per crew in Northeast Florida.

Number of tree trimming crews for main feeder three year cycle and six year lateral cycle

Line Miles	36/17 miles/crew
147 miles (feeders)	1.7
576 miles (laterals)	3.0
Total Resources	4.7
Line Miles (NW FL)	36 miles/crew
112 miles (feeders)	1.0
514 miles (laterals)	2.4
Total Resources	3.4
Line Miles (NE FL)	17 miles/crew
35 miles (feeders)	0.7
62 miles (laterals)	0.6
Total Resources	1.3

Based on the available 2007 average trim rate and the three year main feeder and six year lateral cycle, a total of five crews are required in order to maintain this cycle. Transmission lines in NE FL will be accomplished as possible with the existing tree trimming crews. As indicated above regarding completion of danger tree removal and annual inspection and trimming of critical infrastructure, the company will make reasonable efforts to address these if and when tree trimming crews become available.

FPUC will make reasonable efforts to increase the data collected for the vegetation management program. This data will include the miles of line trimmed annually to ensure the program meets the objectives outlined. Data collected will include detail on trees trimmed, tree density, danger trees removed, etc. which will be used to begin comparing vegetation management productivity with the number of tree related outages. This information will be used to either justify or modify the existing program to ensure maximum cost benefits and reliability improvements. The following table provides year-to-date (2008 to 2009) statistics of our progress within the program.

**FPUC - D&T Vegetation Management Program (3 Yr. Feeder and 6 Yr. Lateral)  
Miles Cleared and Crew Productivity - Program YTD**

Year	Program Yr.	FPUC Combined (NW & NE)					NW - Division					NE - Division				
		Feeders (Miles)	Laterals (Miles)	Total (F & L) Miles	# of Crews	Productivity Avg. (Miles/Crews)	Feeders (Miles)	Laterals (Miles)	Total (F & L) Miles	# of Crews	Productivity Avg. (Miles/Crews)	Feeders (Miles)	Laterals (Miles)	Total (F & L) Miles	# of Crews	Productivity Avg. (Miles/Crews)
2008	1	68.45	87.9	156.35	5	31.27	49.73	86.08	135.81	4	33.95	18.72	1.82	20.54	1	20.54
2009	2	50.59	109	159.59	4.3	37.11	40.23	98.14	138.37	3.3	41.93	10.36	10.86	21.22	1	21.22
2010	3															
2011	4															
2012	5															
2013	6															
<b>YTD Totals</b>		<b>119.04</b>	<b>196.9</b>	<b>315.94</b>	<b>4.7</b>	<b>33.97</b>	<b>89.96</b>	<b>184.22</b>	<b>274.18</b>	<b>3.7</b>	<b>37.56</b>	<b>29.08</b>	<b>12.68</b>	<b>41.76</b>	<b>1</b>	<b>20.88</b>
<b>Total Program Requirements - Miles to be Cleared (MTBC)* Vs. Remaining Miles</b>																
MTBC*		183.42	555.81	739.23			130.21	491.00	621.21			53.21	64.81	118.02		
Remaining		64.38	358.91	423.29			40.25	306.78	347.03			24.13	52.13	76.26		

\*Based on 2008 GIS Information (includes transmission)

## **2.2 Joint-Use Pole Attachment Audit**

FPUC currently has joint use agreements with multiple telecommunication and cable television providers. Although the agreements allow joint use attachments audits, these audits have not been completed as allowed in the contracts. Beginning in 2010, audits will be initiated with all joint use attachers in order to identify the total number of attachments and identify any violations that may exist. GIS mapping information is now available and will be used as a basis when conducting the audits.

FPUC currently has identified a total of 5,877 (2,788 – NW FL and 3,089 – NE FL) telecommunication attachments and 9,341 (6,343 – NW FL and 2,998 – NE FL) cable television attachments within the distribution system. FPUC is also attached to 679 (102 – NW FL and 577 – NE FL) telecommunication poles and 2 (2 – NW FL and 0 – NE FL) cable television poles.

During the inspection process, the following data will be collected for use in analyzing the integrity of joint use poles. Based upon the significant length of time since the last joint use audit, strength and loading assessments will not be completed in this audit. The assessments will be conducted in the pole inspection program described above.

1. Pole Location (GPS information from mapping system)
2. Owner of the pole
3. City/County location
4. Pole type
5. Pole height
6. Pole class
7. Pole treatment
8. Date manufactured
9. Date Inspected (if known)
10. Date retreated (if known)
11. Joint use attachers (company name)
12. Type of joint use attachment
13. Violations
14. Miscellaneous Comments

The information collected in the audit will be compiled and handled in accordance with the specific joint use agreement for that attachment. Any dangerous conditions identified that could result in a failure of the pole will be addressed immediately. The cost to manage the joint use audit and attachment process will be approximately \$25,000 on an annual basis. The joint use audits will be conducted in accordance with the contracts for the third party attachers.

Data collected during the audit process will be analyzed in order to determine the number of poles found to be overloaded, the number of unauthorized joint use attachments and customer outages related to these situations.

## **2.3 Inspection Cycle of Transmission Structures**

Transmission inspections will be completed on all transmission facilities and will include climbing patrols of the 138 KV and 69 KV transmission lines owned by FPUC. This inspection

will ensure that all structures have a detailed inspection performed at a minimum of every six years. The inspection will include ninety five (95) 138 KV structures and two hundred twelve (212) 69 KV structures. A local industrial customer who own 69 KV transmission line structures connected to the FPUC will be strongly encouraged to complete a similar type inspection. Total cost to perform a complete inspection on all structures will be approximately \$ 139,000 (\$23,200 annually).

Transmission substation equipment will also be inspected annually to document the integrity of the facility and identify any deficiencies that require action.

The inspections will ensure that all transmission towers and other transmission line supporting equipment such as insulators, guying, grounding, conductor splicing, cross-braces, cross-arms, bolts, etc structurally sound and firmly attached. Similarly, all transmission substations will be inspected to ensure that all structures, buss work, insulators, grounding, bracing, bolts, etc are structurally sound and firmly attached.

Each inspection will be fully documented in order to provide information in accordance with FPSC guidelines and will reported annually.

#### **2.4 Storm Hardening Activities for Transmission Structures.**

FPUC's existing 138 KV system is constructed using concrete and steel poles or towers and generally comply with the new storm hardening requirements. This system will continue to be inspected as outlined above to ensure the integrity of the system.

FPUC's 69 KV system consist of a total of 212 poles of which 39 are concrete poles. All installations met the NESC code requirements at the time of construction. A policy of replacing all existing wood poles with concrete has been in place for some time. This policy requires that when it becomes necessary to replace a wood pole due to construction requirements or concerns with the integrity of the pole, a concrete pole meeting the current NESC requirements will be utilized.

#### **2.5 Geographic Information System (GIS)**

FPUC has implemented a GIS mapping system in both divisions and had the systems completed and operational in January 2008. The Trimble/UAI system is an ESRI based system using ArcGIS to identify the distribution and transmission facilities overlaid on a land base system. The system locates the facilities on the land base while allowing the ability to enter data on all physical assets within the system. The system also communicates with the Customer Information System to identify usage information and functions as a Customer Outage System that will allow for collection of outage information for use in determining reliability indices.

The GIS will be used as an integral part of the data collection in many of the programs mentioned in this document. This system will also collect information regarding joint use attachments which will provide additional information in conducting joint use audits.

## **2.6 Post-Storm Data Collection and Forensic Analysis**

FPUC has started the process of establishing a forensics oversight team to coordinate communications, schedule data collection activities, and final reporting requirements. Our plans are to utilize a consultant to collect, analyze, and report on field data collected which will be entered into the FPUC Outage manage System (OMS). FPUC will utilize the standard reporting forms located at <http://www.rodtec.org/PURC/> for submitting forensic data to the FPSC.

The following is a copy of the FPUC "FORENSIC DATA COLLECTION AND REPORTING" procedure:

### **FORENSIC DATA COLLECTION AND REPORTING**

#### **PURPOSE:**

To set standards and responsibilities for the collection, assessment, and reporting of storm related damage to FPUC transmission, substation, and distribution structures and equipment. To accomplish these tasks in an orderly manner, safely, and with a minimum of interference with the process of system restoration following a storm.

#### **PROCESS:**

A minimum of 72 hours prior to the storm; FPU will initiate the forensic process by alerting team members both in-house and external of the impending event. All contact information will be verified for accuracy and all equipment will be checked to make sure it is in good working order.

48 hours prior to the storm; begin the process of accessing where the storm is most likely to strike and determine the best locations for forensic teams. Inform team members of more specific information as it becomes available.

24 hours prior to the storm; notify all team members of actual crew personnel, mobilization plan, safety procedures, and reporting instructions.

After the storm; perform a forensic investigation at each location encountered that meets reportable criteria. Damage locations to include but not limited to poles, wires, crossarms, insulators, transformers, reclosers, capacitor banks, cutouts, any other equipment that is damaged or has caused a customer outage.

Damage areas will be determined and teams dispatched utilizing FPU's outage management system, reports from customers, and reports from restoration crews.

#### **RESPONSIBILITIES:**

An FPUC Forensic Team Leader will be assigned and will be responsible for managing the overall forensic effort. This will include tracking storm progress, coordinating team deployment, communication with local ERT Centers, review findings, and generating final reports.

Florida Public Utilities Company will hire a consultant to provide forensic investigative teams that will be responsible for safely collecting information on storm damage. Damaged facilities are defined as broken poles, leaning poles, broken or downed wires, damaged line equipment, and any other incident that has caused a customer outage.

### **REPORTING:**

All post storm forensic data collected will be entered in the PURC form that can be accessed at <http://www.rodtec.org/PURC/> in your browser. The form allows both overhead and underground damage to be entered and data must be entered separately for each incident.

## **2.7 Outage Data for Overhead and Underground Systems**

FPUC will continue to collect outage data for overhead and underground systems in order to evaluate the reliability indices associated with the two systems. The systems are in place for this type analysis and will be further improved with the installation of the automated Customer Outage system.

## **2.8 Coordination with Local Governments**

FPUC actively participates with local governments in planning for emergency situations and necessary communications are established for these situations. Past practice has not included having FPUC personnel at certain government locations at all times during an emergency situation. However, futures plans are to have personnel located at the county EOC's on a 24 hour basis in the future in order to ensure good communications. This will also allow for improved updating of outage information as the storm restoration occurs.

FPUC will also continue to cooperate with local governments in actively discussing both undergrounding and tree trimming issues as they arise. Involvement and discussion regarding both undergrounding and vegetation management issues have allowed for additional communication and education of both parties.

## **2.9 Collaborative Research**

FPUC is currently participating with The Public Utility Research Center (PURC) as well as other investor owned, cooperative and municipal electric utilities in order to perform beneficial research regarding hurricane winds and storm surge within the state PURC has demonstrated the ability to lead and coordinate multiple groups in the research activity. FPUC will continue to support this effort but does not intend to conduct other types of research at this time.

## **2.10 Disaster Preparedness and Recovery Plans**



The primary objective of the Disaster Preparedness and Recovery Plan is to provide guidelines under which Florida Public Utilities Company will operate in emergency conditions. This information is contained with the Emergency Procedures that are updated on an annual basis. The following objectives are included to ensure orderly and efficient service restoration.

1. The safety of employees, contractors and the general public will have the highest priority.
2. Early damage assessment is required in order to develop manpower requirements.
3. Request additional manpower as soon as conditions and information indicate the need.
4. Provide for orderly restoration activities in order to provide efficient and rapid restoration.
5. Provide all logistical needs for employees and contractors.
6. Provide ongoing preparation of our employees, buildings, equipment and support function in advance of an emergency.
7. Provide support and additional resources for employees and their families should they need assistance to address injury or damage as a result of the emergency situation.

FPUC will utilize the plan to prepare for storms annually and will ensure all employees are aware of their responsibilities should the need arise. Based on the location of the storm, the division office in that area will be designated as the operations center and all restoration and logistical activities will be coordinated from that location. Restoration activities will be handled in the following manner:

1. During the early stages of the emergency, restoration will be handled in the usual manner. All service will be restored as soon as possible.
2. As the storm intensifies and trouble reaches major proportions, the main restoration activities will be limited to keeping main feeders energized by clearing trouble without making repairs.
3. When the intensity of the storm is such that work can no longer be done safely, all work will cease and personnel will report to the office or other safe locations.
4. When the storm has subsided to a reasonable level and it is safe to begin restoration activities damage assessment and restoration of main feeders to critical customers will begin.
5. Restoration activities will continue in an effort to restore service in the following manner:
  - a) Substations
  - b) Main feeders to critical customers
  - c) Other main feeders
  - d) Undamaged primary
  - e) Damaged primary, secondary, service, street lights, security lights

These guidelines are not intended to prevent responding to emergency situations. Any life threatening emergency will be handled immediately, in such a manner as to not endanger the lives of others.

Communication efforts with local governments, County EOC's and the media will be a key in ensuring a safe and efficient restoration effort. Key personnel will be designated as the media liaison and will ensure that communications regarding the status of the restoration activities are available on a scheduled basis.

### **3.0 Compliance with NESC Overhead Requirements**

#### **3.1 Distribution**

FPUC distribution facilities have been installed in accordance with NESC requirements in effect at the time of installation. New specifications have been developed that will allow for certain future installations to exceed the NESC by utilizing the extreme wind loading standards.

#### **3.2 Transmission**

FPUC transmission facilities have been installed in accordance with NESC requirements in effect at the time of installation. This plan includes a provision that all remaining wood transmission poles will be replaced with concrete poles that will meet or exceed the NESC extreme wind loading standards. This requires that when it becomes necessary to replace a wood pole due to construction requirements or concerns with the integrity of the pole, a concrete pole meeting the current NESC requirements will be utilized.

#### **3.3 Substation**

FPUC substation facilities have been installed in accordance with NESC requirements in effect at the time of installation. Work has been completed around certain substations that will reduce the possibility of wind blown debris impacting the substation facilities. Efforts will continue to address these situations as practical.

#### **3.4 Extreme Wind Loading for Distribution Facilities**

As required by commission order, FPUC has developed plans to begin incorporating the extreme wind loading standards shown in Figure 250-2(d) of the 2007 NESC code. These standards will be evaluated when new construction and major planned projects are being designed to determine the overall value and contribution to the reliability of the system. If it is determined through a cost benefit analysis that these standards are prudent in the design, they will be incorporated into the design.

The primary focus using the extreme wind loading standards is for distribution facilities along major highways and providing service to critical infrastructure such as hospitals, water plants and sewer treatment plants. FPU is currently developing the list of projects for the 2010 - 2012 time period. This information will be provided when available.

<u>2010</u>	<u>Division</u>	<u>Critical Load</u>	<u>Feeder</u>	<u>Miles</u>	<u>Estimated Cost</u>
	NW	City Hall	9992	0.66	\$150,000.00
<u>2011</u>	<u>Division</u>	<u>Critical Load</u>	<u>Feeder</u>	<u>Miles</u>	<u>Estimated Cost</u>
	NW	Prison/Storm Shelter	9732	2.37	\$180,000.00
	NE	Hospital	209	1.2	\$206,000.00
<u>2012</u>	<u>Division</u>	<u>Critical Load</u>	<u>Feeder</u>	<u>Miles</u>	<u>Estimated Cost</u>
	NW	Water Sanitation	9992	0.91	\$160,000.00
	NE	Sewage Plant	214	0.4	\$77,500.00

#### **4.0 Mitigation of Damage Due to Storm Surge and Flooding**

FPUC is continuing to develop an expanded specifications book that will include details on mitigating damage of underground/overhead distribution and overhead transmission facilities.

Transmission facilities are located only in the Northeast Florida Division. The transmission lines are constructed near and across coastal waterways and were originally designed to meet NESC requirements for these applications. Where necessary, foundations and casings were used to stabilize the structures due to the soil conditions.

Overhead distribution lines in both divisions could be subject to storm surges and flooding. Lines located near the coast or inland rivers that are subject to storm surges or flooding will be evaluated and additional supporting mechanisms placed on them if needed and practical. This may include storm guys or pole bracing where necessary. The storm guys or bracing will be placed so that additional support is achieved perpendicular to the distribution line. Should the affected lines include reclosers, capacitors or regulators that require electronic controls, the controls shall be mounted above maximum surge or flood levels.

Underground distribution lines that could be subject to storm surges and flooding are mainly located in the Northeast Florida Division. Based upon the significant amount of underground infrastructure in place, it is impractical to make a significant impact on what is installed. Current specifications include the use of pads that are placed approximately two feet into the ground that provide additional stability to the installation. Equipment can then be securely attached to the pad. At this time, underground distribution lines are placed in conduit but are not typically encased in concrete. Future installations of underground distribution feeders will be evaluated based on the location. Should a possibility exist that storm surges may impact these facilities, the installation will be evaluated and may be encased in concrete ducts if necessary.

#### **5.0 Placement of New and Replacement Facilities**

FPUC agrees that having facilities located in areas that are easily accessible and pursuant to Rule 25-6.0341, F.A.C. Facilities will be placed along public rights of way or located on private easements that are readily accessible from public streets. These requirements are necessary in order efficiently and safely perform all necessary installation and maintenance on those facilities. Placement of facilities along rear lot lines will not occur except in certain commercial applications where open access concrete/asphalt driveways are located at the rear of the development.

## **6.0 Deployment Strategy**

### **6.1 Description of Facilities Affected**

During the deployment of storm hardening strategy, many changes will be instituted that may have an impact on future storm restoration activities. The changes have been developed; however, the detail specifications and necessary engineering review have not been completed. The technical detail is yet to be developed and is not available for inclusion in this document.

As previously mentioned, these initiatives should be implemented on or before May 2008. The significant areas of implementation are as follows:

1. Wood poles will be inspected so that all poles are inspected at least every eight years. (Note: Based on approval of criteria to exempt certain poles from inspection, this section will be modified)
2. Vegetation management activities will be increased in order to trim main feeders every three years, laterals every six years.
3. Joint use audits will be conducted in an effort to identify pole loading issues. These audits will be conducted once every five years. Additional detailed inspection of pole loading will be completed in conjunction with the wood pole inspection program.
4. Detailed climbing inspections on all transmission line will be conducted so all poles are inspected at least once every six years.
5. The company will continue to replace wood transmission structures with concrete based on development or business needs.
6. A plan has been developed to begin rebuilding distribution lines to critical infrastructure incorporating the extreme wind loading criteria into the design of these systems. The details of this are shown in Section 4.4 above.
7. As new specifications are developed for underground facilities, consideration will be given to techniques that will mitigate damage for storm surges and floods.
8. FPUC will continue the current practice of attempting to place facilities on public rights of way and will ensure private easements are secured if this is not possible.

### **6.2 Communities and Areas Affected by Electric Infrastructure Improvements**

The majority of the items listed in 6.1, Description of Facilities Affected, will affect all areas of the FPUC service territory. The intent is to ensure all areas benefit from these strategies over the term of the work. The transmission line inspections and transmission pole replacements will only affect the Northeast Florida Division since there are no transmission facilities in the Northwest Florida Division. The distribution line rebuilding to comply with the NESC extreme wind loading standards will equally benefit both divisions.

### **6.3 Upgrading of Joint Use Facilities**

FPUC currently proposes that several projects be considered for 2010 – 2012 time period that are intended to upgrade existing facilities to critical infrastructure. It is anticipated that a significant portion of the poles upgraded will have one or more joint use attachments. FPU is currently developing the list of projects for the 2010 -2012 time period. This information will be provided when available.

<u>2010</u>	<u>Division</u>	<u>Critical Load</u>	<u>Feeder</u>	<u>Miles</u>	<u>Pole Est.</u>
	NW	City Hall	9992	0.66	25

<u>2011</u>	<u>Division</u>	<u>Critical Load</u>	<u>Feeder</u>	<u>Miles</u>	<u>Pole Est.</u>
	NW	Prison/Storm Shelter	9732	2.37	40
	NE	Hospital	209	1.2	31

<u>2012</u>	<u>Division</u>	<u>Critical Load</u>	<u>Feeder</u>	<u>Miles</u>	<u>Pole Est.</u>
	NW	Water Sanitation	9992	0.91	30
	NE	Sewage Plant	214	0.4	15

During the design phase of these projects, the NESC extreme wind loading standards will be applied to all poles to be installed and will include all joint use attachments. Current contract language for the joint use attachers involved will be used as a guide for this rebuilding process.

### **6.4 Estimated Cost and Benefits**

Below are shown the items and the associated cost during the 2010 – 2012 time period. Each item should have an impact on the reliability and restoration during storms as well as the normal reliability indices. As previously mentioned, FPUC does not have the supporting data to develop the benefits analysis for these programs. However, as these programs are implemented, data will be collected that can be used in the future to develop the associated benefits.

<u>Item</u>	<u>Description</u>	<u>2010</u>	<u>2011</u>	<u>2012</u>	<u>Comments</u>
1.0	Pole Inspections	\$152,000	\$156,000	\$162,000	3800 poles/year
2.1	Vegetation Management	\$690,000	\$710,000	\$732,000	
2.2	Joint Use Audits	\$25,000	\$26,000	\$27,000	

2.3	Transmission Inspections	\$23,200	\$24,000	\$24,600	
2.4	Trans. Storm Hardening	\$60,000	\$46,000	\$46,000	
2.5	GIS	\$4,000	\$4,000	\$4,000	
2.6	Post Storm Forensics	TBD	TBD	TBD	Dependant on Storm
2.7	OH/UG Data	N/A	N/A	N/A	No Incremental Cost
2.8	Coordination Local Govt.	\$0	\$0	\$0	
2.9	Collaborative Research	\$1,000	\$1,000	\$1,000	
2.10	Disaster Preparedness	N/A	N/A	N/A	No Incremental Cost
3.4	Extreme Wind Loading	\$150,000	\$386,000	\$237,500	Distribution Upgrade

## **7.0 Joint Use Impacts**

### **7.1 Wood Pole Inspections**

During the wood pole inspection process, FPUC will inspect company owned poles in accordance with this plan while all third party poles will be inspected by the owner of those poles. The wood pole inspection process will evaluate the structural soundness of existing poles and perform strength and load test. Documentation will be developed on poles that do not meet the current requirements and corrective actions scheduled.

Based on past experience it is anticipated that approximately 380 joint use poles will be identified annually that need to be replaced. Although it is possible to consider additional bracing for certain poles, most will require replacement. As this occurs, the current contacts with the joint use parties will be utilized to develop the procedures for the replacement and transfer of necessary attachments.

### **7.2 Joint Use Audits**

Joint use audits will be scheduled with all joint users in order to determine attachment amounts and to identify possible loading issues that need to be addressed. All parties should be available for participation in the audits in accordance with the joint use agreements. Due to the length of time since the last audit, it is important that all parties participate.

### **7.3 Attachment Standards and Procedures**

FPUC currently has contracts with each third party attacher that contains the Attachment Standards and Procedures. These contracts will continue in effect and will govern the standards and procedures at this time. As previously mentioned, additional construction specifications will be developed that can be used in conjunction with the contracts. As the additional specifications are developed, third party attachers will have the ability to provide input into the new specifications. Attached to this document are the current Joint Use Attachment Specifications.

### **7.4 Soliciting Input from Third Party Attachers**

At this time, FPUC has sent notification to the following third party attachers concerning the initial Storm Hardening Plan for the years 2010 – 2012 that was submitted to the FPSC on May 3, 2010. There has been no information submitted by third party attachers regarding that plan. Now that this plan has been updated, FPUC will forward this version to the same set of third

party attachers in the near future The "Process to Engage Third Party Attachers" stipulation filed January 29, 2008 and signed by all parties and attached below is still in place. The following is the list of the attachers that were notified:

- Florida Cable Telecommunications Association (FCTA)
- Bellsouth / AT&T
- Embarq (d.b.a. Century Link)

An additional stipulation and agreement with the Florida Cable Telecommunications Association regarding overlashing, pole strength assessments and pole inspections is currently in place but will expire with the approval of this plan.

As information is received from third party attachers regarding this plan, the information will be assembled forwarded to the appropriate parties.

#### **7.5 Estimate of Costs and Benefits from Third Party Attachers**

The estimate of costs and benefits from third party attachers will be forwarded after receipt from third party attachers.





APPENDIX A

Osmose Inspection  
Groundline Decay by Age Group  
Composite

Florida Public Utilities  
Florida - CCA Poles Only / 2008-2009 Distribution Poles

Age Span	Total Poles Inspected	POLES REJECTED				POLES DECAYING AND WEAKENED					TOTAL POLES REJECTED OR DECAYED	
		Interior Decay	Exterior Decay	Other	% of Age Group Total	Interior Decay	Exterior Decay	Interior & Exterior Decay	Other	% of Age Group Total	Pole Count	% of Age Group Total
0-5 Years	547	0	0	0	0.0%	0	14	24	1	7.3%	40	7.3%
6-10 Years	689	0	0	0	0.0%	1	42	31	11	12.3%	85	12.3%
11-15 Years	660	0	0	0	0.0%	1	58	38	25	18.4%	122	18.4%
16-20 Years	550	0	0	0	0.0%	4	66	26	26	22.2%	122	22.2%
21-25 Years	172	0	0	0	0.0%	0	20	19	12	29.7%	51	29.7%
26-30 Years	7	0	0	0	0.0%	0	0	0	2	28.6%	2	28.6%
31-35 Years	0	0	0	0	0.0%	0	0	0	0	0.0%	0	0.0%
36-40 Years	0	0	0	0	0.0%	0	0	0	0	0.0%	0	0.0%
41-45 Years	0	0	0	0	0.0%	0	0	0	0	0.0%	0	0.0%
46-50 Years	0	0	0	0	0.0%	0	0	0	0	0.0%	0	0.0%
51-55 Years	0	0	0	0	0.0%	0	0	0	0	0.0%	0	0.0%
56-60 Years	0	0	0	0	0.0%	0	0	0	0	0.0%	0	0.0%
61+ Years	0	0	0	0	0.0%	0	0	0	0	0.0%	0	0.0%
Unknown	0	0	0	0	0.0%	0	0	0	0	0.0%	0	0.0%
<b>TOTALS</b>	<b>2,625</b>	<b>0</b>	<b>0</b>	<b>0</b>	<b>0.0%</b>	<b>6</b>	<b>200</b>	<b>138</b>	<b>77</b>	<b>16.0%</b>	<b>421</b>	<b>16.0%</b>

Average Age - 12.3



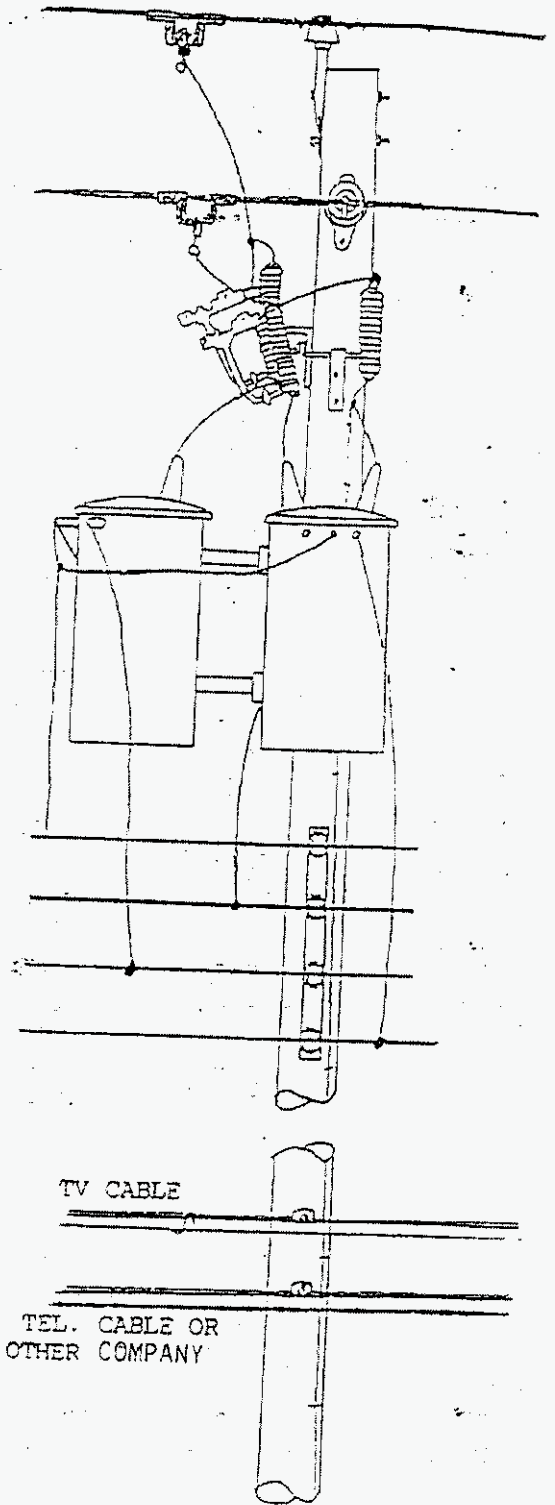
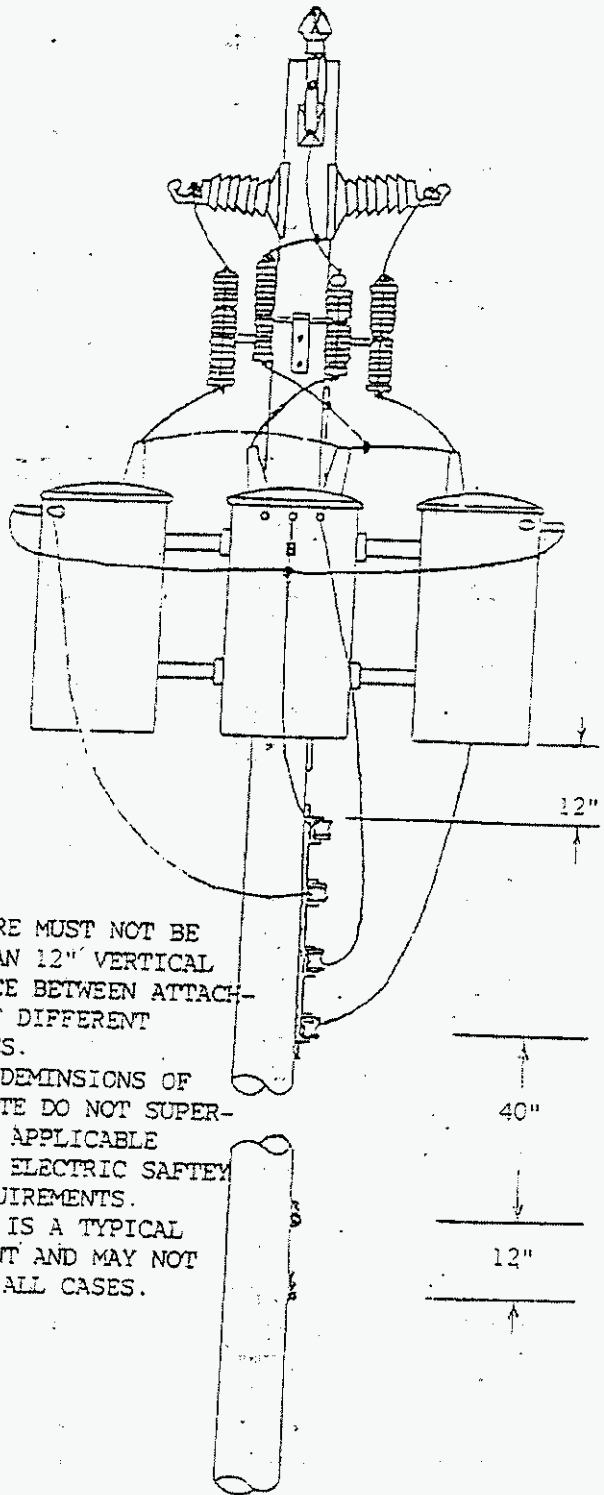

NOTES:

- (1) THERE MUST NOT BE LESS THAN 12" VERTICAL CLEARANCE BETWEEN ATTACHMENTS OF DIFFERENT COMPANIES.
- (2) THE DEMINSIONS OF THIS PLATE DO NOT SUPERSEDE ANY APPLICABLE NATIONAL ELECTRIC SAFTEY CODE REQUIREMENTS.
- (3) THIS IS A TYPICAL ATTACHMENT AND MAY NOT APPLY IN ALL CASES.

Florida Public Utilites, Company  
 Marianna Division  
 STANDARDS

References

dwg. no.

approved by

date

12-29-87

drawn by

B. O'PRY

revised

Supersedes

T CAL COMPANY ATTACHMENT TO FPU POLE

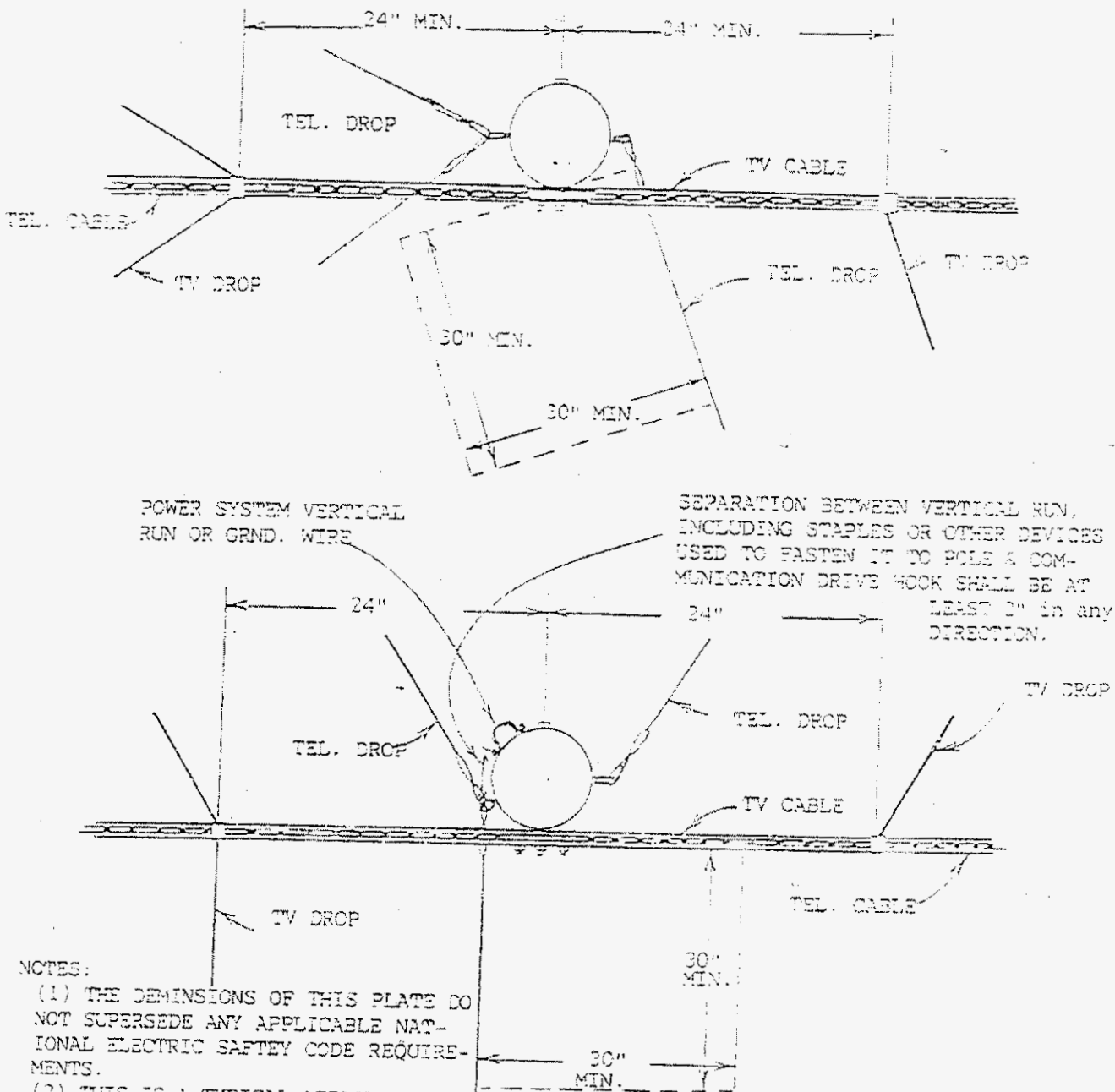

- NOTES:
- (1) THE DIMENSIONS OF THIS PLATE DO NOT SUPERSEDE ANY APPLICABLE NATIONAL ELECTRIC SAFETY CODE REQUIREMENTS.
  - (2) THIS IS A TYPICAL ATTACHMENT AND MAY NOT APPLY IN ALL CASES.
  - (3) THERE MUST NOT BE LESS THAN 12" CLEARANCE BETWEEN ATTACHMENTS OF DIFFERENT COMPANIES.

Florida Public Utilities Company  
 Marianna Division  
**STANDARDS**

References

dwg. no.

Approved by  
 date

10-29-87

drawn by  
 revised

B. D'PRY

Supersedes

GENERAL RULES & SPECIFICATIONS FOR JOINT USE OF FACILITIES

TYPICAL CO. ATTACHMENT TO FPU CO POLE

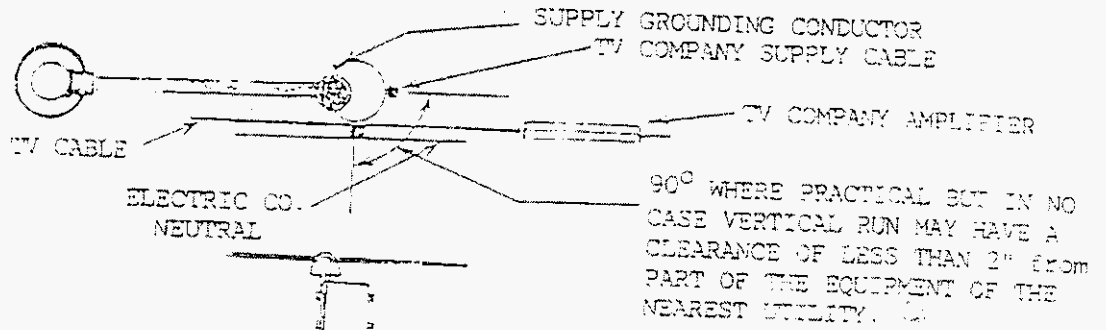

NOTES:

- (1) THERE MUST NOT BE LESS THAN 12" VERTICAL CLEARANCE BETWEEN ATTACHMENTS OF DIFFERENT COMPANIES.
- (2) THE DIMENSIONS OF THIS PLATE DO NOT SUPERSEDE ANY APPLICABLE NATIONAL ELECTRIC SAFETY CODE REQUIREMENTS.
- (3) THIS IS A TYPICAL ATTACHMENT AND MAY NOT APPLY IN ALL CASES.

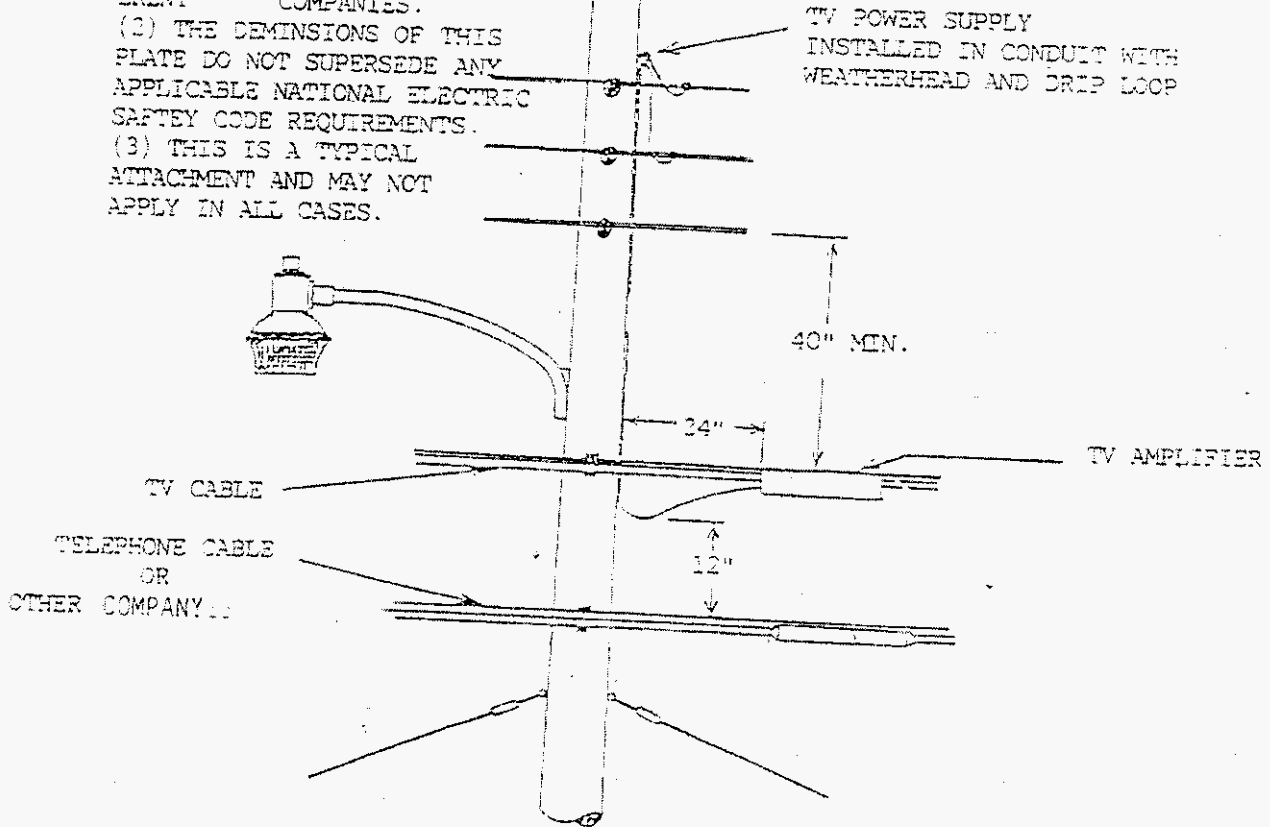

<p>Florida Public Utilities Company Marianna Division STANDARDS</p>	<p>References</p>	<p>dwg. no.</p>	<p>Approved by _____ date 10-29-87 drawn by B. C. PRY revised _____ Supersedes _____</p>
---	-------------------	-----------------	--

TYPE AL CO. ATTACHMENT TO FPU POLE

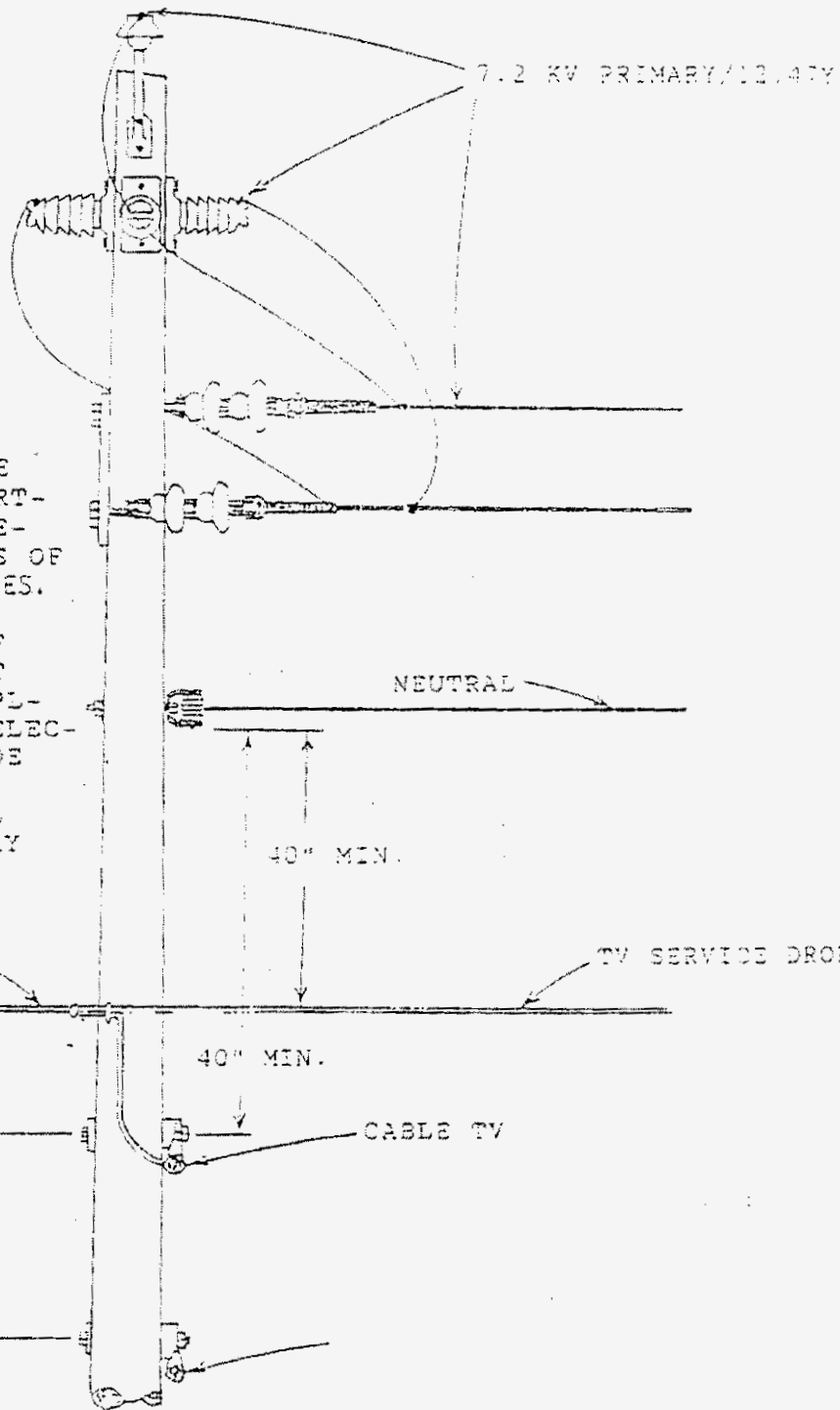

NOTES:

- (1) THERE MUST NOT BE LESS THAN 12" VERTICAL CLEARANCE BETWEEN ATTACHMENTS OF DIFFERENT COMPANIES.
- (2) THE DIMENSIONS OF THIS PLATE DO NOT SUPERSEDE ANY APPLICABLE NATIONAL ELECTRICAL SAFETY CODE REQUIREMENTS.
- (3) THIS IS A TYPICAL ATTACHMENT AND MAY NOT APPLY IN ALL CASES.

TV SERVICE DROP

TV SERVICE DROP

40" MIN.

CABLE TV

12" MIN.

Florida Public Utilities Company  
 Marianna Division  
 STANDARDS

References

dwg. no.

approved by  
 date

12-29-87

drawn by  
 revised

B. J. PRY

Supersedes

GENERAL RULES & SPECIFICATIONS FOR JOINT USE OF FACILITIES

TYPICAL CO. ATTACHMENT TO FPU POLE  
SINGLE TRANSFORMER INSTALLATION

7.2 KV CONSTRUCTION

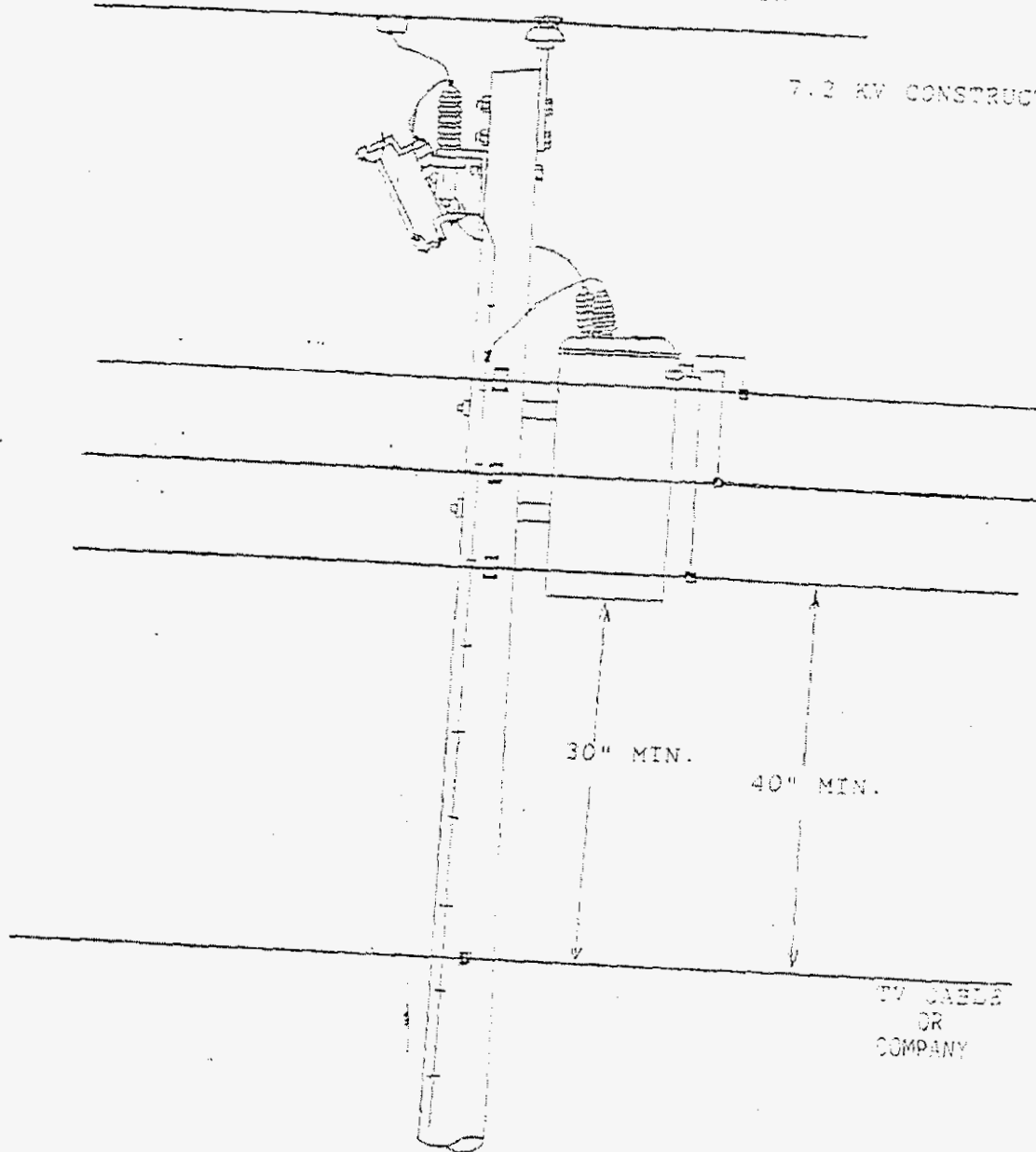

TV CABLES  
OR  
COMPANY

NOTES:

- (1) THERE MUST NOT BE LESS THAN 12" VERTICAL CLEARANCE BETWEEN ATTACHMENTS OF DIFFERENT COMPANIES.
- (2) THE DIMENSIONS OF THIS PLATE DO NOT SUPERSEDE ANY APPLICABLE NATIONAL ELECTRIC SAFETY CODE REQUIREMENTS.
- (3) THIS IS A TYPICAL ATTACHMENT AND MAY NOT APPLY IN ALL CASES.

<p>Florida Public Utilities Company Marianna Division STANDARDS</p>	<p>References</p>	<p>dwg. no.</p>	<p>approved by date drawn by revised supercedes</p>	<p>12-29-87 B. CIPRY</p>
---	-------------------	-----------------	---	------------------------------

GENERAL RULES & SPECIFICATIONS FOR JOINT USE OF FACILITIES

TYPICAL COMPANY ATTACHMENT TO EEP CO POLE

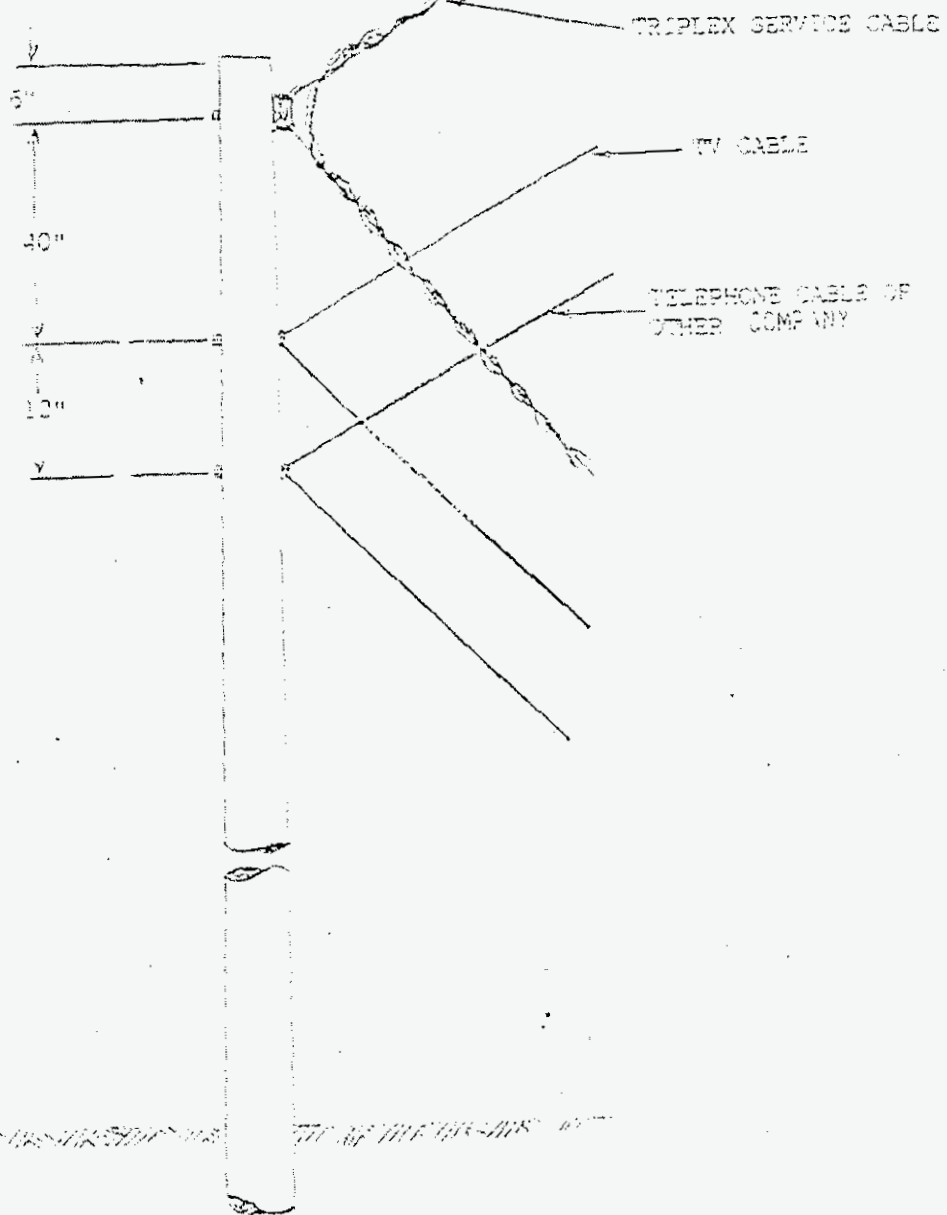

NOTES:

- (1) THERE MUST NOT BE LESS THAN 12" VERTICAL CLEARANCE BETWEEN ATTACHMENTS OF DIFFERENT COMPANIES.
- (2) THE DIMENSIONS OF THIS PLATE DO NOT SUPERSEDE ANY APPLICABLE NATIONAL ELECTRIC SAFTEY CODE REQUIREMENTS.
- (3) THIS IS A TYPICAL ATTACHMENT AND MAY NOT APPLY IN ALL CASES.

Florida Public Utilities Company  
 Marianna Division  
 STANDARDS

References

dwg. no.

Approved by  
 date  
 drawn by  
 revised  
 superseded

11-20-87  
 B. CERRY

ATTACHMENT OF TV DISTRIBUTION

SYSTEM TO POLES

ADDITIONAL REQUIREMENTS

1. Clearance to ground as per National Electrical Safety Code:
  - 20' minimum over streets or alleys
  - 27' minimum over railroad tracks
2. Attachment of telephone and television facilities to be on same side of pole.
3. Metal case on amplifier and terminal boxes and metal case of service switch to be effectively grounded.
4. No amplifiers, distribution terminals and/or fused disconnect switches may be mounted directly to pole, but shall be installed upon a suitable crossarm in approved manner.
5. Telephone and television contacts shall maintain same relative position on poles.
6. Underground cable trays shall be installed on road quarter of pole but shall not conflict with telephone attachments.
7. No amplifier, distribution terminal or fused disconnect switch to be installed upon transformer poles.

FLORIDA PUBLIC UTILITIES  
COMPANY

By \_\_\_\_\_

EXHIBIT V