

State of Florida



Public Service Commission

CAPITAL CIRCLE OFFICE CENTER • 2540 SHUMARD OAK BOULEVARD
TALLAHASSEE, FLORIDA 32399-0850

-M-E-M-O-R-A-N-D-U-M-

DATE: November 22, 2016,
TO: Carlotta S. Stauffer, Commission Clerk, Office of Commission Clerk
FROM: Clayton Lewis, U S Engineering Specialist, Division of Engineering *RES CKL*
RE: Docket No.160144- WU- Application for transfer of Certificate No. 288-W in
Pasco County from Orangeland Water Supply to Orange Land Utilities, LLC.

Please file the attached system identifier information; Consumer Confidence Report and Sanitary Surveys from DEP websites in the above metioned docket file.

Thank you

Terri Jones

From: Clayton Lewis
Sent: Tuesday, November 22, 2016 8:45 AM
To: Terri Jones
Subject: Docket No. 160144-WU et al. (Orange Land Utilities, LLC et al.)
Attachments: Orangeland.pdf

Please file the attached document in Docket No. 160144-WU.

The document includes system identifier information; Consumer Confidence Report and Sanitary Surveys from DEP websites.

Thank you.



Florida
Department of Environmental Protection

[DEP Home](#) / [About DEP](#) / [Programs](#) / [Contact](#) / [Site Map](#) / [Search](#)



Source Water Assessment & Protection Program

- » SWAPP Homepage
- » Search By County
- » Search by PWS Name or Number
- » How to Help?

Definitions

- » Aquifers
- » Public Water Systems
- » Assessment
- » Potential Contaminants
- » Susceptibility
- » Prevention

Contact Us

- » Email
- » Mailing Address
- » Source Water Protection Workshop

EPA Source Water Protection website



Results for: 2014

ORANGELAND SUBDIVISION

2109 OVERVIEW DR
NEW PORT RICHEY, FL 34655

Public Water System ID: 6511307

County: PASCO

DEP Regulatory Office: DEP Southwest District
13051 N Telecom Parkway
Temple Terrace, FL 33637
813-470-5700

Public Water System Type : COMMUNITY

Public Water System Source : GROUND

Primary Use: RESTAURANT

Population Served: 186

Size of Assessment Area:

GROUND: For this system, a 1000-foot radius circle around each well was used to define the assessment area.

Number of Wells: 2

Well ID	Owner ID	FLUWID Status	Well Depth (ft)	Aquifer
15399	WELL #2	AAB4608 ACTIVE	Not Available	
15398	ORANGELAND S/D WELL #1	AAB4607 ACTIVE	Not Available	

Results:

GROUND WATER:

A search of the data sources indicated no potential sources of contamination.

Last updated: May 27, 2016

[Accessibility Information](#)

Copyright © 2012

State of Florida

[Disclaimer](#)

[Exit Disclaimer](#)

[Privacy](#)

[Statement](#)

3900 Commonwealth
Boulevard M.S. 49
Tallahassee, Florida 32399
850-245-2118 (phone) /
850-245-2128 (fax)

[DEP Home](#) | [About DEP](#) | [Contact Us](#) | [Search](#) | [Site Map](#)



Certification of Delivery of Consumer Confidence Report

GENERAL INSTRUCTIONS: This form shall be completed by all community water systems (CWSs) that have prepared a Consumer Confidence Report (CCR) in accordance with Rule 62-550.824, F.A.C., Consumer Confidence Reports. At the end of this form is a certification in which a system's authorized representative shall certify that the reported information is accurate and is in conformance with Rule 62-550.824, F.A.C. **COMPLETE THIS FORM AND SUBMIT IT BY AUGUST 10**, together with a copy of your system's CCR, sample email or water bill (with URL notification of CCR, if applicable), and any newspaper notice(s) and posted notice(s) of your CCR, to the appropriate DEP district office or Approved County Health Department (ACHD). Systems serving 100,000 or more persons posting their CCRs on publicly accessible Internet sites shall provide the information on the appropriate Internet link(s). All information provided on this form must be typed or printed in ink.

I. General Water System Information. (To be completed by all community water systems.)

System name: Orange Land Utilities, LLC Contact person: Mike Smelbridge
PWS Identification number (PWS ID): 6511307 Contact phone number: 863-904-5574
Mailing address: 3336 Grand Blvd. Suite 102 City: Holiday
State: FL Zip: 34690 Population served (not the number of "service connections"):

II. CCR Distribution Method. (To be completed by all community water systems. Choose A or B as appropriate.)

- A. We mailed, emailed, or otherwise directly delivered a copy of our CCR to each customer on 6/1/16 (enter date(s) of mailing or delivery) using the method(s) checked below:
- a. Mailed CCR
 - b. Mailed notice (e.g. water bill) with direct URL to the CCR
 - c. Emailed CCR as an embedded image or as an attachment
 - d. Emailed notice with a direct URL to the CCR
 - e. Otherwise directly delivered CCR to every customer. Explain.

B. We were eligible to use a mailing waiver and used a mailing waiver. (Systems are eligible to use a mailing waiver only if they serve fewer than 10,000 persons, have not had any MCL or monitoring and reporting (M/R) violations, nor have been issued any formal Notices of Violations (NOVs), Consent Orders, Administrative Orders, or court-ordered civil actions during the calendar year before the year the CCR is due to the customers).

Answer a, b, and c below.)

- a. Date of newspaper: _____
- b. Name of newspaper/newsletter that published our CCR: _____
- c. A copy of our notice to customers, informing them that our CCR will not be mailed to them, is attached. This notice was: mailed with bill; published in newspaper/newsletter; or other (describe)

III. Posting of CCR on the Internet. (To be completed by all CWSs serving 100,000 or more persons.)

We posted our CCR on this publicly accessible internet site: _____

IV. Report on Your Effort to Distribute Your CCR to Your Water Consumers.

In addition to the methods selected in Part II,

- A. We posted our CCR on this publicly accessible internet site: _____
- B. We published our CCR in the local newspaper(s). The name(s) and date(s) of the newspaper(s) are: _____

C. We advertised the availability of our CCR as a press release, radio announcement, or TV announcement.
The type(s) and date(s) of the advertisement(s) are: _____

D. We delivered multiple copies of our CCR to single bill addresses serving several persons.

E. We delivered multiple copies of our CCR to the following community organizations:

F. Our CCR was posted in the following public locations: _____

G. Our CCR was distributed by other methods (e.g., additional copies placed in entrance hall to facility). Describe.

V. Use of Non-English Language in CCR. (To be completed by all community water systems.)

Information in a non-English language was included in our CCR because 20% or more of our customers do not speak English but speak _____. The method we used to determine the proportion of non-English speaking customers is _____

This requirement does not apply to our system, because we have no non-English speaking group among our customers equal to or exceeding 20% of our total number of customers.

VI. Other Delivery Requirements. (To be completed by all community water systems.)

(A) Was a copy of your CCR sent to your county health department, as required by rule? Yes No

(B) Is your system regulated by the Public Service Commission (PSC)? Yes No

If Yes, was a copy of your CCR sent to the PSC, as required by rule? Yes No

(C) If your system sells water to other systems, have you provided them with either a copy of your CCR or the required consumer confidence information? Yes No Not Applicable

VII. Certification of Delivery of CCR and Compliance with Regulations. (To be completed by all CWSs.)

This statement certifies that the above named community public water system has distributed its CCR for the time period starting January 1, 2015, and ending December 31, 2015, to its customers on 10/1/16 (mm/dd/yy) and provided the appropriate notices of availability according to the requirements listed in this form, which are also found in Rule 62-550.824, F.A.C. This statement also certifies that the reported information is correct and consistent with the compliance monitoring data for the same period previously submitted to the Department, and that the report has been delivered to the agencies identified in Rules 62-550.824(3)(e)3., and 4., F.A.C.

SIGNATURE OF AUTHORIZED REPRESENTATIVE: Michael Smalbridge

NAME (please print): Michael Smalbridge

TITLE: Managing member DATE: 10/1/16

A copy of our CCR is attached, and

If using electronic delivery, a copy of our sample email or notice (e.g. water bill), with URL leading directly to the CCR and not a general information website, is attached.

2015 Water Quality Report for Orangeland Water Supply PWS ID# 651-1307

We're pleased to present to you this year's Annual Water Quality Report. We want to keep you informed about the excellent water and services we deliver to you over the past year. Our goal is and always has been, to provide you with a safe and dependable supply of drinking water. Our water is obtained from two wells which draw from the Floridan Aquifer. The water is chlorinated for disinfection purposes. This report shows our water quality results and what they mean.

In 2015 the Department of Environmental Protection performed a Source Water Assessment on our water system and a search of the data sources indicated no potential source of contamination near our wells. The assessment results are available on the FDEP Source Water Assessment and Protection Program website at www.dep.state.fl.us/swapp.

Orangeland Water Supply routinely monitors for contaminants in your drinking water according to Federal and State laws, rules, and regulations. Except where indicated otherwise, this report is based on the results of our monitoring for the period of January 1 to December 31, 2015. Data obtained before January 1, 2015, and presented in this report are from the most recent testing done in accordance with the laws, rules, and regulations.

If you have any questions about this report or concerning your water utility, please contact Aqua Environmental Solutions, Inc. at (352) 848-5415. We encourage our valued customers to be informed about their water utility.

In the table below, you may find unfamiliar terms and abbreviations. To help you better understand these terms we've provided the following definitions:

Action Level (AL): The concentration of a contaminant which, if exceeded, triggers treatment or other requirements that a water system must follow.
Initial Distribution System Evaluation (IDSE): An important part of the Stage 2 Disinfection Byproducts Rule (DBPR). The IDSE is a one-time study conducted by water systems to identify distribution system locations with high concentrations of trihalomethanes (THMs) and haloacetic acids (HAAs). Water systems will use results from the IDSE, in conjunction with their Stage 1 DBPR compliance monitoring data, to select compliance monitoring locations for the Stage 2 DBPR.

Maximum Contaminant Level or MCL: The highest level of a contaminant that is allowed in drinking water. MCLs are set as close to the MCLGs as feasible using the best available treatment technology.

Maximum Contaminant Level Goal or MCLG: The level of a contaminant in drinking water below which there is no known or expected risk to health. MCLGs allow for a margin of safety.

Maximum residual disinfectant level or MRDL: The highest level of a disinfectant allowed in drinking water. There is convincing evidence that addition of a disinfectant is necessary for control of microbial contaminants.

Maximum residual disinfectant level goal or MRDLG: The level of a drinking water disinfectant below which there is no known or expected risk to health. MRDLGs do not reflect the benefits of the use of disinfectants to control microbial contaminants.

ND: means not detected and indicates that the substance was not found by laboratory analysis.

Parts per million (ppm) or Milligrams per liter (mg/l): one part by weight of analyte to 1 million parts by weight of the water sample.

Parts per billion (ppb) or Micrograms per liter (µg/l): one part by weight of analyte to 1 billion parts by weight of the water sample.

Pecurie per liter (pCi/L): measure of the radioactivity in water.

Water Quality Monitoring Results

Radioactive Contaminants							
Contaminant and Unit of Measurement	Dates of sampling (mo./yr.)	MCL Violation Y/N	Level Detected	Range of Results	MCLG	MCL	Likely Source of Contamination
Uranium (µg/L)	Dec 2015	N	2.3	N/A	0	30	Erosion of natural deposits
Inorganic Contaminants							
Contaminant and Unit of Measurement	Dates of sampling (mo./yr.)	MCL Violation Y/N	Level Detected	Range of Results	MCLG	MCL	Likely Source of Contamination
Arsenic (ppb)	Dec 2015	N	4.1	N/A	0	10	Erosion of natural deposits; runoff from orchards; runoff from glass and electronics production wastes
Barium (ppm)	Dec 2015	N	0.022	N/A	2	2	Discharge of drilling wastes; discharge from metal refineries; erosion of natural deposits
Beryllium (ppb)	Dec 2015	N	0.13	N/A	4	4	Discharge from metal refineries and coal-burning factories; discharge from electrical, aerospace, and defense industries
Chromium (ppb)	Dec 2015	N	14	N/A	100	100	Discharge from steel and pulp mills; erosion of natural deposits
Fluoride (ppm)	Dec 2015	N	0.096	N/A	4	4.0	Erosion of natural deposits; discharge from fertilizer and aluminum factories. Water additive which promotes strong teeth when at the optimum level of 0.7ppm
Lead (point of entry) (ppb)	Dec 2015	N	1.4	N/A	0	15	Residue from man-made pollution such as auto emissions and paint; lead pipe, casing, and solder
Nitrate (as Nitrogen) (ppm)	Dec 2015	N	1.4	N/A	10	10	Runoff from fertilizer use; leaching from septic tanks, sewage; erosion of natural deposits

Nickel (ppb)	Dec 2015	N	5.2	N/A	N/A	100	Pollution from mining and refining operations. Natural occurrence in soil
Selenium (ppb)	Dec 2015	N	5.2	N/A	50	50	Discharge from petroleum and metal refineries; erosion of natural deposits; discharge from mines
Sodium (ppm)	Dec 2015	N	15	N/A	N/A	160	Salt water intrusion, leaching from soil
Stage 2 Disinfectants and Disinfection By-Products (1)							
Disinfectant or Contaminant and Unit of Measurement	Dates of sampling (mo./yr.)	MCL or MRDL Violation Y/N	Level Detected	Range of Results	MCLG or MRDLG	MCL or MRDL	Likely Source of Contamination
Chlorine (ppm)	2015 (monthly)	N	0.9	0.6 - 1.2	MRDLG = 4	MRDL = 4.0	Water additive used to control microbes
Haloacetic Acids (five) (HAAS) (ppb)	Sept 2015	N	4.07	N/A	NA	MCL = 60	By-product of drinking water disinfection
TTHM [Total trihalomethanes] (ppb)	Sept 2015	N	5.5	N/A	NA	MCL = 80	By-product of drinking water disinfection
Lead & Copper (Tap Water)							
Contaminant and Unit of Measurement	Dates of sampling (mo./yr.)	AL Exceeded (Y/N)	90 th Percentile Result	No. of sampling sites exceeding the AL	MCLG	AL (Action Level)	Likely Source of Contamination
Lead and Copper (Tap Water)							
Copper (tap water) (ppm)	Sept 2015	N	.532	0	1.3	1.3	Corrosion of household plumbing systems; erosion of natural deposits; leaching from wood preservatives
Lead (tap water) (ppb)	Sept 2015	N	1.95	0	15	15	Corrosion of household plumbing systems, erosion of natural deposits

If present, elevated levels of lead can cause serious health problems, especially for pregnant women and young children. Lead in drinking water is primarily from materials and components associated with service lines and home plumbing. Holiday Oaks is responsible for providing high quality drinking water, but cannot control the variety of materials used in plumbing components. When your water has been sitting for several hours, you can minimize the potential for lead exposure by flushing your tap for 30 seconds to 2 minutes before using water for drinking or cooking. If you are concerned about lead in your water, you may wish to have your water tested. Information on lead in drinking water, testing methods, and steps you can take to minimize exposure is available from the Safe Drinking Water Hotline or at <http://www.epa.gov/safewater/lead>.

The sources of drinking water (both tap water and bottled water) include rivers, lakes, streams, ponds, reservoirs, springs, and wells. As water travels over the surface of the land or through the ground, it dissolves naturally occurring minerals and, in some cases, radioactive material, and can pick up substances resulting from the presence of animals or from human activity.

Contaminants that may be present in source water include:

- (A) Microbial contaminants, such as viruses and bacteria, which may come from sewage treatment plants, septic systems, agricultural livestock operations, and wildlife.
- (B) Inorganic contaminants, such as salts and metals, which can be naturally-occurring or result from urban stormwater runoff, industrial or domestic wastewater discharges, oil and gas production, mining, or farming.
- (C) Pesticides and herbicides, which may come from a variety of sources such as agriculture, urban stormwater runoff, and residential uses.
- (D) Organic chemical contaminants, including synthetic and volatile organic chemicals, which are by-products of industrial processes and petroleum production, and can also come from gas stations, urban stormwater runoff, and septic systems.
- (E) Radioactive contaminants, which can be naturally occurring or be the result of oil and gas production and mining activities.

In order to ensure that tap water is safe to drink, the EPA prescribes regulations, which limit the amount of certain contaminants in water provided by public water systems. The Food and Drug Administration (FDA) regulations establish limits for contaminants in bottled water, which must provide the same protection for public health.

Drinking water, including bottled water, may reasonably be expected to contain at least small amounts of some contaminants. The presence of contaminants does not necessarily indicate that the water poses a health risk. More information about contaminants and potential health effects can be obtained by calling the Environmental Protection Agency's Safe Drinking Water Hotline at 1-800-426-4791.

Some people may be more vulnerable to contaminants in drinking water than the general population. Immuno-compromised persons such as persons with cancer undergoing chemotherapy, persons who have undergone organ transplants, people with HIV/AIDS or other immune system disorders, some elderly, and infants can be particularly at risk from infections. These people should seek advice about drinking water from their health care providers. EPA/CDC guidelines on appropriate means to lessen the risk of infection by *Cryptosporidium* and other microbiological contaminants are available from the Safe Drinking Water Hotline (800-426-4791).

We at Orangeland Water Supply are committed to ensuring the quality of your water. If you have any questions or concerns about the information provided, please feel free to call any of the numbers listed.



Florida Department of Environmental Protection

Southwest District Office
13051 North Telecom Parkway
Temple Terrace, FL 33637-0926

Rick Scott
Governor

Carlos Lopez-Cantera
Lt. Governor

Jonathan P. Steverson
Secretary

July 15, 2015

Fred Snell, Owner
Orangeland Subdivision
2109 Overview Drive
New Port Richey, FL 34655
BSNELL5@HOTMAIL.COM

Re: CAO Closure Letter
Orangeland Subdivision
Facility ID Number 651-1307
Pasco County

Dear Mr. Snell:

Department personnel conducted a file review of the above-referenced system on July 6, 2015. Based on the information provided, the system was determined to be in compliance.

The Department appreciates your efforts to maintain this system in compliance with state and federal rules. Should you have any questions or comments, please contact James Brock at (813) 470-5737, or via e-mail at: james.brock@dep.state.fl.us.

Sincerely,

A handwritten signature in blue ink that reads "Kelly Bishop".

Kelly L. Bishop, PG
Assistant Director
Compliance Assurance Program
Southwest District
Florida Department of Environmental Protection

Craciun, Cynthia

From: Craciun, Cynthia on behalf of Watson, Edward
Sent: Tuesday, August 19, 2014 2:17 PM
To: 'phenti32@msn.com'
Cc: Henry, Danielle D.; Watson, Edward; SWD_Clerical (Shared Mailbox)
Subject: PWS-651-1307-CAO-ltr and Insp. Rpt.
Attachments: CAO.pdf; Orangeland Subdivision 05-27-14 CI.pdf

Sent on behalf of
Edward Watson.

A copy was mailed to:
Fred Snell, Owner
Orangeland Subdivision
2109 Overview Drive
New Port Richey, FL 34655

Dear Mr. Findlay:

Attached please find the above subject documents. In an effort to reduce costs and waste, our agency is moving to electronic rather than paper correspondence. This is the only copy that you will receive, unless you request otherwise.

Acrobat Reader 6.0 or greater is required to read this document. It is available for downloading at:
<http://www.adobe.com/products/acrobat/readstep.html>.

If you have any questions concerning the contents of the attached document, please contact the FDEP Environmental Manager Edward Watson at (813)470-5796 or via email Edward.Watson@dep.state.fl.us.

Sincerely,

Cynthia Craciun
Department of Environmental Protection
13051 North Telecom Parkway
Temple Terrace, FL 33637-0926

The Department of Environmental Protection values your feedback as a customer. DEP Secretary Herschel T. Vinyard Jr. is committed to continuously assessing and improving the level and quality of services provided to you. Please take a few minutes to comment on the quality of service you received. Simply click on this link to the DEP Customer Survey. Thank you in advance for completing the survey.



**FLORIDA DEPARTMENT OF
ENVIRONMENTAL PROTECTION**
13051 North Telecom Parkway
Temple Terrace, Florida 33637-0926

RICK SCOTT
GOVERNOR

CARLOS LOPEZ-CANTERA
LT. GOVERNOR

HERSCHEL T. VINYARD JR.
SECRETARY

August 19, 2014

Fred Snell, Owner
Orangeland Subdivision
2109 Overview Drive
New Port Richey, FL 34655

Re: Compliance Assistance Offer
Orangeland Subdivision
Facility ID No.: 651-1307
Pasco County

Dear Mr. Snell,

A compliance inspection was conducted at your facility on May 27, 2014, under the authority of Section 403.061, Florida Statutes (F.S.). During this inspection, possible violations of Chapter 403, F.S., Chapter 62-550, Florida Administrative Code (F.A.C.), and Chapter 62-555, F.A.C. were observed. The purpose of this letter is to offer you compliance assistance as a means of resolving these matters.

Please see the attached inspection report for a full account of Department observations and be advised this Compliance Assistance Offer is part of an agency investigation preliminary to agency action in accordance with Section 120.57(5), F.S. We request you review the items of concern noted in the attached inspection report and respond in writing within **15 days** of receipt of this Compliance Assistance Offer. Your written response should either:

1. Describe what you have done to resolve the issue (see "Recommendations for Corrective Action" section of the report),
2. Provide information that either mitigates the concerns or demonstrates them to be invalid, or
3. Arrange for one of our inspectors to visit your facility to offer suggested actions to return to compliance without enforcement.

It is the Department's desire that you are able to document compliance or corrective actions concerning the possible violations identified in the attached inspection report so that this matter can be closed without enforcement. Your failure to respond promptly in writing (or by e-mail) may result in the initiation of formal enforcement proceedings.

Orangeland Subdivision
Facility ID No.: 651-1307
Compliance Assistance Offer
Page 2 of 2

Please address your response and any questions to Edward Watson of the Southwest District Office at (813) 470-5875, or via e-mail at Edward.Watson@dep.state.fl.us. We look forward to your cooperation with this matter.

Sincerely,



Kelly L. Bishop, PG
Assistant Director
Southwest District
Florida Department of Environmental Protection

KLB/xx/xx

Enclosures: Inspection Report

cc: Scott Findlay, Operator, phenti32@msn.com

ec: Danielle Henry, FDEP, Danielle.D.Henry@dep.state.fl.us

SYSTEM	Water system: <u>ORANGELAND SUBDIVISION</u>	System PWS #: <u>6511307</u>	Inspection Date: <u>05/27/2014</u>
	Inspector: <u>JOSEPHINE BENWELL</u>	Person(s) contacted: <u>SCOTT FINDLAY</u>	System Type: <u>C</u>
System address: <u>8323 LIMAN DRIVE</u>		City: <u>NEW PORT RICHEY</u>	State: <u>FL</u> Zip: <u>34653</u>
OWNER	Owner name: <u>FRED SNELL</u>	Owner title: <u>OWNER</u>	
	Owner address: <u>2109 OVERVIEW DRIVE</u>	City: <u>NEW PORT RICHEY</u>	State: <u>FL</u> Zip: <u>34655</u>
	Owner phone: <u>727-514-1778</u>	Email: <u>See Remarks</u>	
Operator required? <input checked="" type="checkbox"/> Yes <input type="checkbox"/> No (If "No", Operator sections not applicable)		Operator class & cert. number: <u>B 4804</u>	
Operator name: <u>SCOTT FINDLAY</u>		Phone: <u>727-403-8306</u>	

S = SATISFACTORY U = UNSATISFACTORY ~ = NOT APPLICABLE * = SEE COMMENT BELOW

SOURCE - WELL INFORMATION				STORAGE			
Well Number/Well ID #	1	2	AAB4607; AAB4608 - SEE REMARKS	Tank(s)/Type(s)	1	Hydro - 1000 gallons	
Well head sealed? (Pad/conduit/openings)	S	S		Inspections compliant? (annual/5yr)	~		
Well casing 12" above grade?	S	S		Pressure Gauge Compliant	S		
Casing vent compliant? (2003)	S	S		Pressure relief valve provided? (hydro)	S		
Check valve compliant?	*	S		Security measures compliant?	S		
Raw tap compliant?	S	S		DISTRIBUTION			
Flowmeter/Timeclock	S		Model: Elster	Water system map compliant?	~		
Well Pad Compliant?	S	S		Flushing of dead ends compliant?	See Remarks		
Security measures compliant?	S	S		Valve maintenance compliant?	See Remarks		
TREATMENT				Chlorine residual > 0.2 mg/L	Yes		
O & M logbook compliant?	S			MANAGEMENT			
O & M manual compliant?	S			Number of high service pumps?	~		
Auxiliary Power	~			Flow meter accuracy checked?	See Recommendations		
Loss of chlorine alarm compliant?	~			ERP / CCC Plans Onsite?	~ / Yes		
Treated sample tap provided?	S			OPERATOR			
Cl solution NSF approved?	S			Operator visits compliant?	Yes		
Cl storage complaint	S			Plant checked 5 times per week?	No - 3 visits/week		
Chlorinator	S		Model: Chem-Tech 30 GPD	Last inspection fully compliant? <input type="checkbox"/> Yes <input checked="" type="checkbox"/> No (see below)			
Cl room compliant?				Have deficiencies been addressed?	No		
Scales compliant?				Were any of the deficiencies "repeat"?	Yes		
Auto switchover provided?				FIELD SAMPLING RESULTS			
Safety switch compliant?				Plant Cl (mg/L)	0.75		
OTHER				Distribution Cl mg/L	3.68	Location:	7423 Knoll Drive
Aeration							
pH adjustment							
Orthophosphate							

* Was not able to verify during the inspection because there was no handle on the raw tap.

REMARKS AND RECOMMENDATIONS

- Please provide an owner contact email address to the Department.
- Well 1 (AAB4607) is the eastern well and Well 2 (AAB4608) is the western well. The western well has a new submersible pump installed (see previous deficiency from 3/26/2010 inspection).
- The floor drain appeared rusted and did not appear to have a grate.
- Records indicated that blow-offs were conducted on a quarterly basis.



DEFICIENCIES

BIO-GROWTH ON THE DRAIN PIPE OF THE TANK

REGULATION REFERENCE: 62-555.350(2), F.A.C.

RECOMMENDED ACTION: Please either remove the bio-growth and flush on a regular basis, or, if you plan to not use this drain pipe, please install an end cap.

RUST ON THE WESTERN WELL (AAB4608) CASING

REGULATION REFERENCE: 62-555.350(2), F.A.C.

RECOMMENDED ACTION: Please provide the Department a schedule to remove the rust from the well casing.

UN-SCREENED PIPE AT THE EASTERN WELL (AAB4607)

REGULATION REFERENCE: 62-555.320(8)(c), F.A.C.

RECOMMENDED ACTION: Please screen the pipe at the eastern well (AAB4607).

TECHNICAL ASSISTANCE PROVIDERS

FLORIDA RURAL WATER ASSOCIATION

2970 Wellington Circle W, Suite 101



Tallahassee FL 32309-6885

E-Mail: FRWA@frwa.net

Home Page: <http://www.frwa.net>

850.668.2746

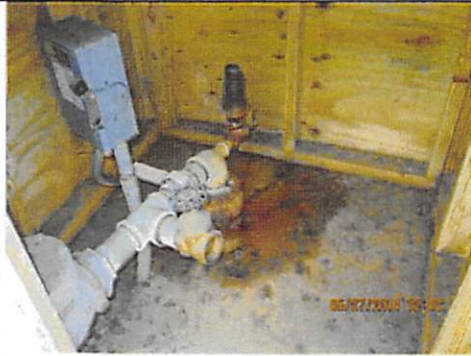
PICTURES

		
<p>Well 2 (Western) – AAB4608</p>	<p>Well 2 (Western) – AAB4608</p>	<p>Well 1 (Eastern) – AAB4607</p>



Well 1 (Eastern) – AAB4607



Well 1 (Eastern) – Pipe without mesh screen



Pressure Gauge

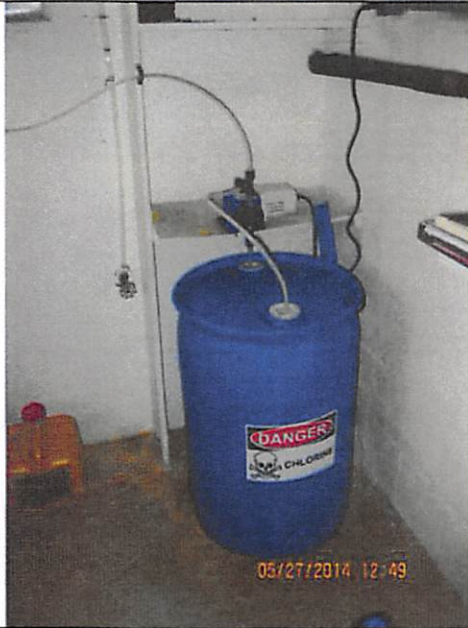

Chlorine Storage and Pump



Floor Drain

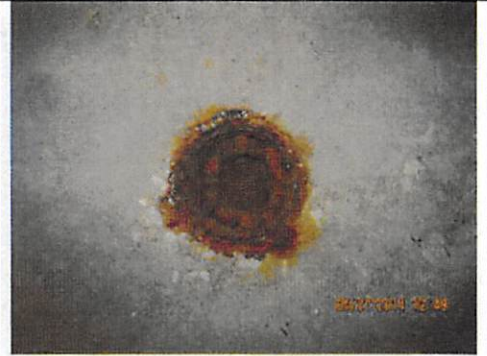

Floor Drain



Sight Glass



Flow Meter



Hydro Tank



Well ID Labels



Treated Sample Tap on Hydro Tank



Air Leaking



Hydro Tank



Tank Drain Pipe with bio-growth

Type of Camera Used: Canon Powershot A1000 IS
 Digital Recording Media: Kingston Technology 2GB Memory Card
 Were the Photos Altered? (Yes or No): No
 Photographer: Josephine Benwell

PHOTOGRAPH INFORMATION

INSPECTOR'S SIGNATURE Josephine Benwell

TITLE Environmental Specialist II DATE AUGUST 13, 2014

REVIEWED BY Ed [Signature]

TITLE Environmental Manager DATE AUGUST 13, 2010



Florida Department of Environmental Protection

Southwest District Office
13051 North Telecom Parkway
Temple Terrace, Florida 33637-0926

August 22, 2011

Rick Scott
Governor

Jennifer Carroll
Lt. Governor

Herschel T. Vinyard Jr.
Secretary

Mr. Fred Snell
2109 Overview Drive
New Port Richey, Florida 34655

Re: Sanitary Survey Report
Orangeland Subdivision
PWS-ID No. 651-1307
Pasco County

Dear Mr. Snell:

Enclosed please find a copy of the Sanitary Survey Report for the above-referenced potable water system. You are requested to review all listed deficiencies and to notify this office within 30 days, in writing, of the corrective actions taken or planned.

If you have any questions or concerns, please contact me at, (813) 632-7600, extension 317, or e-mail: jamie.l.lewis@dep.state.fl.us.

Sincerely,

Jamie Lewis
Environmental Specialist II
Drinking Water Section

JL/dsm

Enclosure

cc: Scott Findlay, Operator, phenti32@msn.com

SURVEY	Water system: <u>ORANGELAND SUBDIVISION</u>	System PWS #: <u>6511307</u>	Date of survey: <u>08/5/2011</u>
	Inspector name: <u>JAMIE LEWIS</u>	Person(s) contacted: <u>SCOTT FINDLAY</u>	
	System type: <u>C</u> Population: <u>186</u> Connections: <u>75</u> Design capacity: <u>100,000</u> Storage capacity: <u>1,000</u>		
SYSTEM	System address: <u>8323 LIMAN DRIVE</u>	City <u>NEW PORT RICHEY</u> State <u>FL</u> Zip <u>34653</u>	
	System phone: _____	Cell: _____	
	Fax number: _____	Email: _____	
OWNER	Owner name: <u>FRED SNELL</u>	Owner title: <u>OWNER</u>	
	Owner address: <u>2109 OVERVIEW DRIVE</u>	City: <u>NEW PORT RICHEY</u> State <u>FL</u> Zip <u>34655</u>	
	Owner phone: <u>727-848-1590</u>	Cell: _____	
	Fax number: _____	Email: _____	
OPERATOR	Operator required? <input checked="" type="checkbox"/> Yes <input type="checkbox"/> No (If "No", Operator sections not applicable)	Operator class & cert. number: <u>B 4804</u>	
	Operator name: <u>SCOTT FINDLAY</u>	Phone: <u>727-403-8306</u>	
	Fax number: <u>727-939-1015</u>	Email: <u>phenti32@msn.com</u>	

SOURCE - WELL INFORMATION	Well 1	Well 2	STORAGE FACILITIES		
	Well Name and/or FL Unique Well ID	AAB4607		AAB4608	Storage type used: <input checked="" type="checkbox"/> Hydro <input type="checkbox"/> Ground <input type="checkbox"/> Elevated <input type="checkbox"/> Bladder <input type="checkbox"/> N/A
Well head sealed? (Pad/conduit/openings)	Yes	Yes	Inspections compliant? (annual/5yr)	NA-no hatch	
Well casing 12" above grade?	No < 12"	No < 12"	Washouts compliant? (every 5 yrs)	*	
Casing vent compliant?(installed, screened)	See Deficiencies	See Deficiencies	Storage capacity compliant?(1/4 max)	*	
Check valve compliant? (installed/no leak)	Yes	Yes	HYDRO APPURTENANCES: "X" box below if not compliant, <input type="checkbox"/> PRV <input type="checkbox"/> Gauge <input type="checkbox"/> Sight glass <input type="checkbox"/> Bypass <input type="checkbox"/> Drain <input checked="" type="checkbox"/> Compliant		
Tap Compliant? (Smooth/1/2" high/precheck)	Yes	Yes	GROUND/ELEVATED APPURTENANCES: "X" box below if not compliant . NA <input type="checkbox"/> Hatch <input type="checkbox"/> Vent <input type="checkbox"/> Overflow <input type="checkbox"/> Drain <input type="checkbox"/> Bypass <input type="checkbox"/> Compliant		
Flow measurable? (if applicable, GPM@psi)	Yes Kent 2" in-line meter		Manual or automatic controls?	Automatic	
Flow meter accuracy checked?	See Deficiencies		On/Off pressure of pumps?	Well 1: 45/60 Well 2: 42/50	
Well capacity > maximum day?	*	*	HSP High Service Pumps functional?	N/A	
Setbacks compliant?(hazard type and distance)	*	*	HSP HSP capacity compliant?	N/A	
Name of plant & type of chlorination	Main Plant/ Hypo		Chlorine test kit compliant?	Yes	
O & M log compliant?	Yes		Chlorine grab sampling compliant?	Yes	
O & M manual compliant?	Yes		Bacti sampling compliant?	Yes	
Cl storage compliant? (no organics/acid/sun)	Yes		Chemical sampling compliant?	Yes	
Chlorinator flow proportionate?	Yes Pulsafeeder 30 GPD		Lead/copper sampling compliant?(C,P)	Yes	
Treated sample tap provided?	Yes		DBP monitoring compliant?(C,P)	Yes	
TREATMENT	HYPO CL	Cl solution strength?	10.5%	MONITORING PLANS: "X" box below if not compliant <input checked="" type="checkbox"/> Bacteriological <input checked="" type="checkbox"/> Disinfection By-Products (C,P) <input checked="" type="checkbox"/> Lead & Copper (C,P)	
		Solution tank compliant?(covered/etc)	Yes	MANAGERIAL NSF: "X" box below if not compliant <input type="checkbox"/> Treatment Chemicals/Components <input type="checkbox"/> Storage <input type="checkbox"/> Pipe <input type="checkbox"/> New Meters	
		Antisiphon protection compliant?	Yes		
GAS CL	AERATE	Safety: (Gloves/Apron/Eyewash/etc)	No	CCC / Plan(C) implemented?	Yes
		Cl room compliant?(separate/ventilation)	N/A	Record keeping compliant?	See Deficiencies and Recommendations
		Scales compliant? (installed/functional)	N/A	Security measures compliant?	Yes
DISTRIBUTION	AERATE	Safety: (SCBA/Gloves/Ammonia)	N/A	Plant category and type?	Cat V / Class D
		Choose type: "X" box below if not compliant Not applicable <input type="checkbox"/> Screen <input type="checkbox"/> Tray <input type="checkbox"/> Lid <input type="checkbox"/> Bypass <input type="checkbox"/> Drain <input type="checkbox"/> Algae Free <input type="checkbox"/> Compliant		Plant checked 5 days/week? (owner/rep)	Yes
		Flushing of dead ends compliant?	See Recommendations	Operator visits compliant?	Yes 3 visits/week
		Valve maintenance compliant?	See Recommendations	MORs submittal compliant?	Yes
		Distribution PSI compliant? (> 20 PSI)	Yes		
		Chlorine residual above minimum?	Yes		

FIELD SAMPLING RESULTS	Plant Cl (mg/L) /pH	1.36/	Distribution Cl (mg/L) /pH	1.23**/
TECHNICAL ASSISTANCE PROVIDERS (TAP) RECOMMENDED?	<input type="checkbox"/> Yes (see enclosed TAP information)		<input type="checkbox"/> No TAP recommended at this time	
COMMENTS: *Unable to verify at time of inspection. **Distribution system chlorine sample taken at 7335 Knoll Drive.				

DEFICIENCIES

DEFICIENCY: INADEQUATE WELL CASING VENT SCREEN.

REGULATION REFERENCE: Rule 62-555.320(8)(c), Florida Administrative Code, (F.A.C.)

RECOMMENDED ACTION: Water systems are required to provide a proper well casing vent, (screen), to prevent suction of insects, rodents, or debris. The vent shall terminate in a downturned position, at or above the top of the casing or pitless unit, no less than 12 inches above grade or floor, in a minimum 1 ½ inch diameter opening covered with a 24 mesh, corrosion resistant screen. The pipe connecting the casing to the vent shall be of adequate size to provide rapid venting of the casing. Please install a 24 mesh, corrosion resistant screen on the well casing vents for both wells.

REPEAT DEFICIENCY: NO RECORDS OF FLOW METER ACCURACY CHECK.

REGULATION REFERENCE: Rule 62-555.350(2), F.A.C.

RECOMMENDED ACTION: Systems are required to maintain and calibrate master meters in accordance with the manufacturer's recommendation. Schedule a flow meter accuracy testing within the next 30 days. A copy of the report is to be maintained onsite and a copy sent to the Department.

DEFICIENCY: RUSTED AND LEAKING CHLORINE INJECTION POINT.

REGULATION REFERENCE: Rule 62-555.350 (2), F.A.C.

RECOMMENDED ACTION: Repair the leak at the Chlorine injection point.

DEFICIENCY: LEAKS IN STORAGE TANK.

REGULATION REFERENCE: Rule 62-555.350 (2), F.A.C.

RECOMMENDED ACTION: Rehabilitate the exterior of the hydropneumatic storage tank.

DEFICIENCY: NO WRITTEN BACTERIOLOGICAL SAMPLING PLAN.

REGULATION REFERENCE: Rule 62-550.518(1), F.A.C.

RECOMMENDED ACTION: All public water systems must have a written Bacteriological sampling plan that addresses, at a minimum, location, timing, frequency and rotation period of sample sites that are representative of water throughout the distribution system. Please submit the plan to this office within 30 days and have available for review during your next inspection.

DEFICIENCY: NO WRITTEN DISINFECTION BY-PRODUCT MONITORING PLAN, (DBPP).

REGULATION REFERENCE: Rule 62-550.821(10), F.A.C.

RECOMMENDED ACTION: Water systems shall make their monitoring plan available for review during sanitary surveys conducted by the Department and shall submit their monitoring plan if requested by the Department in accordance with Rule 62-550.821, F.A.C. Please submit the plan to this office within 30 days and have available for review during your next inspection.

DEFICIENCY: NO LEAD AND COPPER MONITORING PLAN.

REGULATION REFERENCE: Rule 62-555.900(12), F.A.C.

RECOMMENDED ACTION: All community and non-transient non-community public water systems must have a Lead and Copper sampling plan. Please submit the plan to this office within 30 days and have available for review during your next inspection.

REMARKS AND RECOMMENDATIONS**NO RECORDS OF DEAD-END WATER MAINS FLUSHING.**

Rule 62-555.350 (2), F.A.C., provides that dead-end water mains conveying finished drinking water shall be flushed quarterly or in accordance with a written flushing program established by the supplier of water; additionally, dead-end or other water mains conveying finished water shall be flushed as necessary whenever legitimate water quality complaints are received. Please ensure that flushing will be performed as required and documented in the operation and maintenance log.

NO RECORDS OF VALVE EXERCISING.

Rule 62-555.350 (2), F.A.C., provides that preventive maintenance on electrical or mechanical equipment, including exercising of isolation valves, shall be performed in accordance with the equipment manufacturer's recommendations. Please ensure that the valves are exercised as required and documented in the operation and maintenance log.

NO SCREEN ON PRESSURE RELIEF VALVE FOR STORAGE TANK.

Rule 62-555.350(2), F.A.C., requires that storage tanks are checked annually to ensure screens are in place. Please place a screen on the pressure relief valve located on the hydropneumatic storage tank.

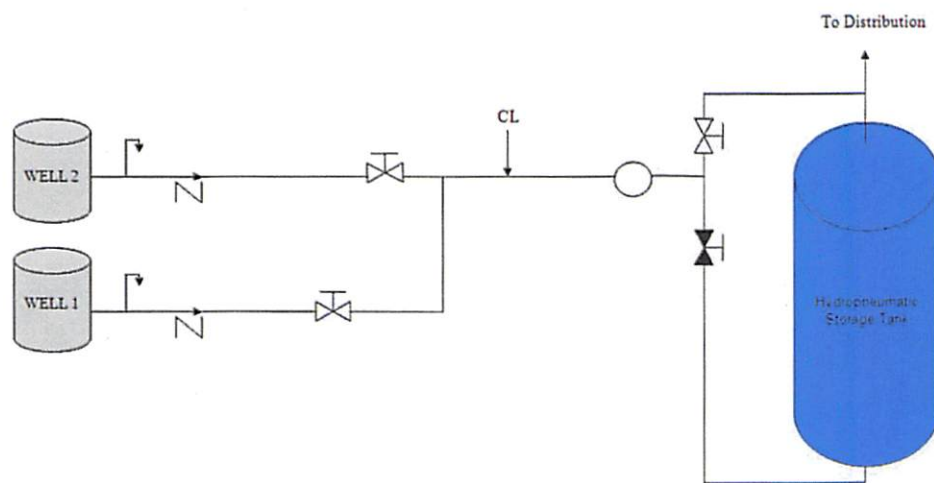
SYSTEM SCHEMATIC**TECHNICAL ASSISTANCE PROVIDERS**

FLORIDA RURAL WATER ASSOCIATION
2970 Wellington Circle W, Suite 101
Tallahassee FL 32309-6885
E-Mail: FRWA@frwa.net
Home Page: <http://www.frwa.net>
850.668.2746

MAPS OR DIRECTIONS TO SYSTEM (text and/or graphics)

Take FL-54 west. Turn right and head north on Little Road. Turn left and head west on Liman Road.

DIGITAL PHOTOS



Well #1 (AAB4607) - well casing vent needs screen



Well #2 (AAB4608) - well casing vent needs screen



Chlorine injection point is rusted and leaking



Pressure relief valve on tank needs screen



Leak on the underside of storage tank

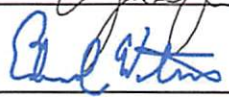

Leak on the underside of storage tank

INSPECTOR'S SIGNATURE  TITLE ES DATE: 8/15/11
REVIEWED BY  TITLE ENV. MGR. DATE: 8-19-11

COMPLIANCE MONITORING COMMUNITY PUBLIC WATER SYSTEMS WITH POPULATION LESS THAN 350					
CONTAMINANT	# Samples Require d	Sampling			
		Location	Frequency	Sample Date	Due Date
Microbiological (Bacte)	1	Each well	monthly	monthly	monthly
	2	Distribution	monthly	monthly	monthly
Volatile Organics	1	POE	3 years (Notes A, 2)	2012	2012
Synthetic Organics	1	POE	3 years (Note 2)(may submit SOC waiver in 2015 & 2018)	2012	2012
Nitrate & Nitrite (as N)	1	POE	annually	2011	2011
Inorganics	1	Each POE	3 years (Note 2)	2012	2012
Asbestos	1 (Note F)	Distribution	9 years (Note 4)	2012	2012
Secondaries	1	Each POE	3 years (Note 2)	2012	2012
Radionuclides	(Note C)	Each POE	3, 6, or 9 years (Note 2)	2015	2015
Lead and Copper	(Note D)	---	---	June-Sept. 2012	October 10, 2012
DBP (Stage 1)	1 / plant	Max Res	Quarterly, annually, or triennial (Note 7)	July-Sept. 2012	October 10, 2012

POE = Point of Entry (Samples shall be taken at each entry point to the distribution system that is representative of each source after treatment.)

Note A See Rule 62-550.515(1), F.A.C. Each system shall take four consecutive quarterly samples during its assigned year in the system's first compliance period. If no contaminant is detected, the system shall monitor annually during the next three-year compliance period. If still no contaminants are detected, systems shall take one sample during each subsequent three-year compliance period.

Note C See Rule 62-550.519, F.A.C

Note D Contact the Southwest District Drinking Water Program at 813-632-7600 or contact the Florida Rural Water Association.

Note F See Rule 62-550.511(4), F.A.C. A system without asbestos-containing components shall certify to the Department in writing, using DEP Form No. 62-555.910(10), that it is asbestos free. Certification shall satisfy subsections (1), (2), and (3) of the referenced rule, and shall be submitted each nine-year compliance cycle during the specified year the system is required to monitor.

Note 2 Second year of each three-year compliance period (calendar years 2006, 2009, 2012, etc.).

Note 4 Second year of each nine-year compliance cycle (calendar years 2006, 2009, etc.).

Note 7 Requirements vary. Please contact your local District/County office for specific information.