

451

RECEIVED-FPSC



BellSouth Telecommunications, Inc  
Suite 400  
150 South Monroe Street  
Tallahassee, Florida 32301-1556

NOV 10 PM 4:39

Marshall M. Criser III  
Regulatory Vice President

RECORDS AND REPORTING

November 10, 1999

Mrs. Blanca S. Bayo  
Director, Division of Records and Reporting  
Florida Public Service Commission  
2540 Shumard Oak Boulevard  
Tallahassee, Florida 32399

991696-TP

Re: Approval of the Interconnection Agreement Negotiated by BellSouth Telecommunications, Inc. ("BellSouth") and Supra Telecommunications & Information Systems, Inc. pursuant to Sections 251, 252 and 271 of the Telecommunications Act of 1996

Dear Mrs. Bayo:

Pursuant to section 252(e) of the Telecommunications Act of 1996, BellSouth and Supra Telecommunications & Information Systems, Inc. are submitting to the Florida Public Service Commission their renegotiated agreement for the interconnection of their networks, the unbundling of specific network elements offered by BellSouth and the resale of BellSouth telecommunications services to Supra Telecommunications & Information Systems, Inc. The agreement was negotiated pursuant to sections 251, 252 and 271 of the Act.

Pursuant to section 252(e) of the Act, the Commission is charged with approving or rejecting the renegotiated agreement between BellSouth and Supra Telecommunications & Information Systems, Inc. within 90 days of its submission. The Commission may only reject such an agreement if it finds that the agreement or any portion of the agreement discriminates against a telecommunications carrier not a party to the agreement or the implementation of the agreement or any portion of the agreement is not consistent with the public interest, convenience and necessity. Both parties represent that neither of these reasons exists as to the agreement they have negotiated and that the Commission should approve their agreement.

Very truly yours,

*Marshall M. Criser III*  
Regulatory Vice President  
(22)

DOCUMENT NUMBER-DATE  
~~12071~~ NOV 10 99  
FPSC-RECORDS/REPORTING

## ATTACHMENT TO TRANSMITTAL LETTER

The Agreement entered into by and between BellSouth Telecommunications, Inc. and Supra Telecommunications and Information Systems, Inc., dated October 5, 1999, for the state of Florida consists of the following:

ITEM	NO. PAGES
Adoption Papers	3
Exhibit 1	1
Title Page	1
Table of Contents	3
General Terms and Conditions	66
Attachment 1	9
Attachment 2	109
Attachment 3	49
Attachment 4	8
Attachment 5	5
Attachment 6	27
Attachment 7	49
Attachment 8	6
Attachment 9	4
Attachment 10	7
Attachment 11	9
Attachment 12	18
Attachment 13	12
Attachment 14	2
Attachment 15	12
Letter dated 06/10/97	1
Replacement pages	21
Letter dated 08/21/97	1
Replacement pages	5
Letter dated 07/24/98	1
Replacement pages	8
Amendment	4
TOTAL	441

## AGREEMENT

*09/29/99* This Agreement, which shall become effective as of the *5th* day of 1999, is entered into by and between Supra Telecommunications and Information Systems, Inc., ("Supra") a Florida corporation on behalf of itself, and BellSouth Telecommunications, Inc., ("BellSouth"), a Georgia corporation, having an office at 675 W. Peachtree Street, Atlanta, Georgia, 30375, on behalf of itself and its successors and assigns.

**WHEREAS**, the Telecommunications Act of 1996 (the "Act") was signed into law on February 8, 1996; and

**WHEREAS**, section 252(i) of the Act and 47 C.F.R. §51.809 require BellSouth to make available any individual interconnection, service, or network element provided under an agreement approved by the appropriate state regulatory body to any other requesting telecommunications carrier upon the same terms and conditions as those provided in the agreement;

**NOW, THEREFORE**, in consideration of the promises and mutual covenants of this Agreement, Supra and BellSouth hereby agree as follows:

1. Supra and BellSouth shall adopt the interconnection agreement executed between BellSouth and AT&T Communications of the Southern States, Inc. for the state of Florida ("BellSouth/AT&T Interconnection Agreement") dated June 10, 1997 and any and all amendments to said agreement executed and approved by the appropriate state regulatory commission as of the date of the execution of this Agreement. The BellSouth/AT&T Interconnection Agreement and all amendments are attached hereto as Exhibit 1 and incorporated herein by this reference. The adoption of this agreement with amendment(s) consists of the following:

ITEM	NO. PAGES
Adoption Papers	3
Title Page	1
Table of Contents	3
General Terms and Conditions	66
Attachment 1	9
Attachment 2	109
Attachment 3	49
Attachment 4	8
Attachment 5	5
Attachment 6	27
Attachment 7	49
Attachment 8	6

*PCF*  
09/29/99

Attachment 9	4
Attachment 10	7
Attachment 11	9
Attachment 12	18
Attachment 13	12
Attachment 14	2
Attachment 15	12
Letter dated 06/10/97	1
Replacement pages	21
Letter dated 08/21/97	1
Replacement pages	5
Letter dated 07/24/98	1
Replacement pages	8
Amendment	4
TOTAL	440

2. The term of this Agreement shall be from the effective date as set forth above and shall expire as set forth in section 2 of the BellSouth/AT&T Interconnection Agreement. For the purposes of determining the expiration date of this Agreement pursuant to section 2 of the BellSouth/AT&T Interconnection Agreement, the effective date shall be June 10, 1997.
3. Supra shall accept and incorporate any amendments to the BellSouth/AT&T Interconnection Agreement executed as a result of any final judicial, regulatory, or legislative action.
4. Every notice, consent, approval, or other communications required or contemplated by this Agreement shall be in writing and shall be delivered in person or given by postage prepaid mail, addressed to:

**BellSouth Telecommunications, Inc.**

CLEC Account Team  
9<sup>th</sup> Floor  
600 North 19<sup>th</sup> Street  
Birmingham, Alabama 35203

And

General Attorney – COU  
Suite 4300  
675 W. Peachtree St.  
Atlanta, GA 30375

**Supra Telecommunications and  
Information Systems, Inc.**



*PIT*

09/29/99



Olukayode Ramos  
2620 SW 27<sup>th</sup> Ave  
Miami, FL 33133

Or at such other address as the intended recipient previously shall have designated by written notice to the other Party. Where specifically required, notices shall be by certified or registered mail. Unless otherwise provided in this Agreement, notice by mail shall be effective on the date it is officially recorded as delivered by return receipt or equivalent, and in the absence of such record of delivery, it shall be presumed to have been delivered the fifth day, or next business day after the fifth day, after it was deposited in the mail.

IN WITNESS WHEREOF, the Parties have executed this Agreement through their authorized representatives.

**BellSouth Telecommunications, Inc.**

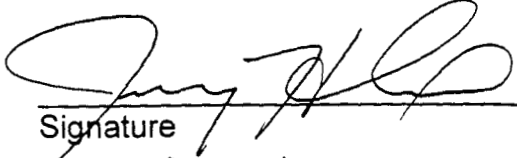
  
\_\_\_\_\_  
Signature

Jerry D. Hendrix  
\_\_\_\_\_  
Name

10/5/99  
\_\_\_\_\_  
Date

**Supra Telecommunications and Information Systems, Inc.**

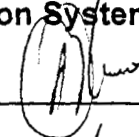
  
\_\_\_\_\_  
Signature

O.A. Ramos  
\_\_\_\_\_  
Name

10/04/99  
\_\_\_\_\_  
Date

 PC7  
09/29/99

**Exhibit 1  
To  
Supra Telecommunication and Information Systems, Inc.  
Agreement**

*LB*

AGREEMENT

between

BellSouth Telecommunications, Inc.  
and AT&T Communications of the Southern States, Inc.

Effective Date: June 10, 1997

FLORIDA

*UB*

FL6/10/97

## TABLE OF CONTENTS

<u>Section</u>	<u>Page</u>
AGREEMENT .....	•
PREFACE .....	•
RECITALS .....	•
DEFINITIONS and ACRONYMS .....	•
GENERAL TERMS AND CONDITIONS .....	2
1. Provision of Local Service and Unbundled Network Elements.....	2
2. Term of Agreement .....	4
3. Termination of Agreement; Transitional Support.....	4
4. Good Faith Performance .....	4
5. Option to Obtain Local Services, Network Elements and Combinations Under Other Agreements .....	5
6. Responsibility of Each Party.....	5
7. Governmental Compliance.....	5
8. Responsibility For Environmental Contamination.....	6
9. Regulatory Matters .....	7
10. Liability and Indemnity.....	8
11. Audits and Inspections .....	10
12. Remedies for Failure to Meet DMOQs .....	12
13. Customer Credit History .....	12
14. Force Majeure .....	12
15. Certain Federal, State and Local Taxes.....	13
16. Alternative Dispute Resolution .....	16
17. Notices .....	17

*JB*  
FL5/10/97

18. Confidentiality and Proprietary information	17
19. Branding	19
20. Directory Listings Requirements	20
21. Subscriber List Information/Local Number Portability	21
22. Miscellaneous	23
<b>Part I: Local Services Resale</b>	<b>27</b>
23. Telecommunications Services Provided for Resale	27
24. General Terms and Conditions for Resale	28
25. Requirements for Specific Services	29
26. DELETED	35
27. Support Functions	36
28. Service Functions	39
<b>PART II: UNBUNDLED NETWORK ELEMENTS</b>	<b>48</b>
29. Introduction	48
30. Unbundled Network Elements	48
<b>PART III: ANCILLARY FUNCTIONS</b>	<b>51</b>
31. Introduction	51
32. BellSouth Provision of Ancillary Functions	51
33. Standards for Ancillary Functions	51
<b>PART IV: PRICING</b>	<b>53</b>
34. General Principles	55
35. Local Service Resale	55
36. Unbundled Network Elements	55
37. Compensation For Call and Transport Termination	55
38. Ancillary Functions	55

39. Local Number Portability	55
40. Recorded Usage Data	55
41. Electronic Interfaces	55

## ATTACHMENTS

Attachment 1	Alternative Dispute Resolution
Attachment 2	Services Description: Unbundled Network Elements
Attachment 3	Service Description: Ancillary Functions
Attachment 4	Provisioning and Ordering
Attachment 5	Maintenance
Attachment 6	Connectivity Billing and Recording
Attachment 7	Provision of Customer Usage Data
Attachment 8	Local Number Portability
Attachment 9	Network Security
Attachment 10	Acronyms
Attachment 11	Definitions
Attachment 12	Performance Measurement
Attachment 13	BAPCO Agreement
Attachment 14	Bona Fide Request Process
Attachment 15	Interface Requirements for Ordering and Provisioning, Maintenance and Repair, and Pre-Ordering

## AGREEMENT

### PREFACE

This Agreement, which shall become effective as of the 10th day of June, 1997, is entered into by and between AT&T Communications of the Southern States, Inc., a New York Corporation, having an office at 1200 Peachtree Street, N.E., Atlanta, Georgia 30309, on behalf of itself, its successors and assigns, (individually and collectively "AT&T"), and BellSouth Telecommunications, Inc. ("BellSouth"), a Georgia corporation, on behalf of itself, its successors and assigns, having an office at 675 West Peachtree Street, Atlanta, Georgia 30375.

### RECITALS

WHEREAS, The Telecommunications Act of 1996 (the "Act") was signed into law on February 8, 1996; and

WHEREAS, the Act places certain duties and obligations upon, and grants certain rights to Telecommunications Carriers; and

WHEREAS, BellSouth is an Incumbent Local Exchange Carrier; and

WHEREAS, BellSouth is willing to provide Telecommunications Services for resale, Interconnection, Unbundled Network Elements and Ancillary Functions which include, but are not limited to, access to poles, ducts, conduits and rights-of-way, and collocation of equipment at BellSouth's Premises on the terms and subject to the conditions of this Agreement; and

WHEREAS, AT&T is a Telecommunications Carrier and has requested that BellSouth negotiate an Agreement with AT&T for the provision of Interconnection, Unbundled Network Elements, and Ancillary Functions as well as Telecommunications Services for resale, pursuant to the Act and in conformance with BellSouth's duties under the Act.

NOW, THEREFORE, in consideration of the promises and the mutual covenants of this Agreement, AT&T and BellSouth hereby agree as follows:

### DEFINITIONS and ACRONYMS

For purposes of this Agreement, certain terms have been defined in Attachment 11 and elsewhere in this Agreement to encompass meanings that may differ from, or be in addition to, the normal connotation of the defined word. Unless the context clearly indicates otherwise, any term defined or used

  
FLB/10/97

in the singular shall include the plural. The words "shall" and "will" are used interchangeably throughout this Agreement and the use of either connotes a mandatory requirement. The use of one or the other shall not mean a different degree of right or obligation for either Party. A defined word intended to convey its special meaning is capitalized when used. Other terms that are capitalized, and not defined in this Agreement, shall have the meaning in the Act. For convenience of reference, Attachment 10 provides a list of acronyms used throughout this Agreement.

## GENERAL TERMS AND CONDITIONS

### Provision of Local Service and Unbundled Network Elements

This Agreement sets forth the terms, conditions and prices under which BellSouth agrees to provide (a) Telecommunications Service that BellSouth currently provides, or may offer hereafter for resale along with the Support Functions and Service Functions set forth in this Agreement (hereinafter collectively referred to as "Local Services") and (b) certain unbundled Network Elements, or combinations of such Network Elements ("Combinations") and (c) Ancillary Functions to AT&T (Local Services, Network Elements, Combinations, and Ancillary Functions, collectively referred to as "Services and Elements"). This Agreement also sets forth the terms and conditions for the interconnection of AT&T's network to BellSouth's network and the mutual and reciprocal compensation for the transport and termination of telecommunications. BellSouth may fulfill the requirements imposed upon it by this Agreement by itself or, in the case of directory listings for white pages may cause BellSouth Advertising and Publishing Company ("BAPCO") to take such actions to fulfill BellSouth's responsibilities. This Agreement includes Parts I through IV, and their Attachments 1 - 15 and all accompanying Appendices and Exhibits. Unless otherwise provided in this Agreement, BellSouth will perform all of its obligations hereunder throughout its entire service area. The Parties further agree to comply with all provisions of the Act, including Section 271(e) (1).

- 1 A The Services and Elements provided pursuant to this Agreement may be connected to other Services and Elements provided by BellSouth or to any Services and Elements provided by AT&T itself or by any other vendor. AT&T may purchase unbundled Network Elements for the purpose of combining Network Elements in any manner that is technically feasible, including recreating existing BellSouth services.
- 1 1 Subject to the requirements of this Agreement, AT&T may, at any time add, relocate or modify any Services and Elements purchased hereunder. Requests for additions or other changes shall be handled pursuant to the Bona Fide Request Process provided in Attachment 14. Terminations of any



FL6/10/97



Services or Elements shall be handled pursuant to Section 3.1 of the General Terms and Conditions of this Agreement.

1.2 BellSouth shall not discontinue any Network Element, Ancillary Function, or Combination provided hereunder without the prior written consent of AT&T. Such consent shall not be unreasonably withheld. BellSouth shall not discontinue any Local Service provided hereunder unless BellSouth provides AT&T prior written notice of intent to discontinue any such service. BellSouth agrees to make any such service available to AT&T for resale to AT&T's Customers who are subscribers of such services from AT&T until the date BellSouth discontinues any such service for BellSouth's customers. BellSouth also agrees to adopt a reasonable, nondiscriminatory transition schedule for BellSouth or AT&T Customers who may be purchasing any such service.

1.3 This Agreement may be amended from time to time as mutually agreed in writing between the Parties. The Parties agree that neither Party will take any action to proceed, nor shall either have any obligation to proceed on a requested change unless and until a modification to this Agreement is signed by authorized representatives of each Party.

## 2. Term of Agreement

2.1 When executed by authorized representatives of BellSouth and AT&T, this Agreement shall become effective as of the Effective Date stated above, and shall expire three (3) years from the Effective Date unless terminated in accordance with the provisions of Section 3.2 of the General Terms and Conditions.

2.2 No later than one hundred and eighty (180) days prior to the expiration of this Agreement, the Parties agree to commence negotiations with regard to the terms, conditions, and prices of a follow-on agreement for the provision of Services and Elements to be effective on or before the expiration date of this Agreement ("Follow-on Agreement"). The Parties further agree that any such Follow-on Agreement shall be for a term of no less than three (3) years unless the Parties agree otherwise.

2.3 If, within one hundred and thirty-five (135) days of commencing the negotiation referenced to Section 2.2, above, the Parties are unable to satisfactorily negotiate new terms, conditions and prices, either Party may petition the Commission to establish an appropriate Follow-on Agreement pursuant to 47 U.S.C. § 252. The Parties agree that in such event they shall encourage the Commission to issue its order regarding such Follow-on Agreement no later than the expiration date of this Agreement. The Parties further agree that in the event the Commission does not issue its order by the expiration date of this Agreement, or if the Parties continue beyond the expiration date of this

  
FL5/10/97

Agreement to negotiate without Commission intervention, the terms, conditions and prices ultimately ordered by the Commission, or negotiated by the Parties will be effective, retroactive to the day following the expiration date of this Agreement. Until the Follow-on Agreement becomes effective, BellSouth shall provide Services and Elements pursuant to the terms, conditions and prices of this Agreement that are then in effect. Prior to filing a Petition pursuant to this Section 2.3, the Parties agree to utilize the informal dispute resolution process provided in Section 3 of Attachment 1.

### **3 Termination of Agreement; Transitional Support**

3.1 AT&T may terminate any Local Service(s), Network Element(s), Combination(s), or Ancillary Function(s) provided under this Agreement upon thirty (30) days written notice to BellSouth unless a different notice period or different conditions are specified for termination of such Local Service(s), Network Element(s), or Combination(s) in this Agreement or pursuant to any applicable tariff, in which event such specific period or conditions shall apply, provided such period or condition is reasonable, nondiscriminatory and narrowly tailored. Where there is no such different notice period or different condition specified, AT&T's liability shall be limited to payment of the amounts due for any terminated Local Service(s), Network Element(s), Combination(s) or Ancillary Service provided up to and including the date of termination. Notwithstanding the foregoing, the provisions of section 10, infra, shall still apply. Upon termination, BellSouth agrees to cooperate in an orderly and efficient transition to AT&T or another vendor such that the level and quality of the Services and Elements is not degraded and to exercise its best efforts to effect an orderly and efficient transition. AT&T agrees that it may not terminate the entire Agreement pursuant to this section.

3.2 If a Party is in breach of a material term or condition of this Agreement ("Defaulting Party"), the other Party shall provide written notice of such breach to the Defaulting Party. The Defaulting Party shall have ten (10) business days from receipt of notice to cure the breach. If the breach is not cured, the Parties shall follow the dispute resolution procedure of Section 16 of the General Terms and Conditions and Attachment 1. If the Arbitrator determines that a breach has occurred and the Defaulting Party fails to comply with the decision of the Arbitrator within the time period provided by the Arbitrator (or a period of thirty (30) days if no time period is provided for in the Arbitrator's order), this Agreement may be terminated in whole or part by the other Party upon sixty (60) days prior written notice.

### **4 Good Faith Performance**

In the performance of their obligations under this Agreement, the Parties shall act in good faith and consistently with the intent of the Act. Where notice,

*UB*  
PLS/10/97

approval or similar action by a Party is permitted or required by any provision of this Agreement, including, without limitation, the obligation of the Parties to further negotiate the resolution of new or open issues under this Agreement; such action shall not be unreasonably delayed, withheld or conditioned

5 **Option to Obtain Local Services, Network Elements and Combinations Under Other Agreements**

If as a result of any proceeding or filing before any Court, State Commission or the Federal Communications Commission, voluntary agreement or arbitration proceeding pursuant to the Act or pursuant to any applicable state law BellSouth becomes obligated to provide Services and Elements, whether or not presently covered by this Agreement, to a third Party at rates or on terms and conditions more favorable to such third Party than the applicable provisions of this Agreement, AT&T shall have the option to substitute such more favorable rates, terms, and conditions for the relevant provisions of this Agreement which shall apply to the same States as such other Party, and such substituted rates, terms or conditions shall be deemed to have been effective under this Agreement as of the effective date thereof. BellSouth shall provide to AT&T any BellSouth agreement between BellSouth and any third Party within fifteen (15) days of the filing of such agreement with any state Commission.

6. **Responsibility of Each Party**

Each Party is an independent contractor, and has and hereby retains the right to exercise full control of and supervision over its own performance of its obligations under this Agreement and retains full control over the employment, direction, compensation and discharge of all employees assisting in the performance of such obligations. Each Party will be solely responsible for all matters relating to payment of such employees, including compliance with social security taxes, withholding taxes and all other regulations governing such matters. Each Party will be solely responsible for proper handling, storage, transport and disposal at its own expense of all (i) substances or materials that it or its contractors or agents bring to, create or assume control over at Work Locations or, (ii) Waste resulting therefrom or otherwise generated in connection with its or its contractors' or agents' activities at the Work Locations. Subject to the limitations on liability and except as otherwise provided in this Agreement, each Party shall be responsible for (i) its own acts and performance of all obligations imposed by Applicable Law in connection with its activities, legal status and property, real or personal and, (ii) the acts of its own affiliates, employees, agents and contractors during the performance of that Party's obligations hereunder.

7 **Governmental Compliance**

AT&T and BellSouth each shall comply at its own expense with all Applicable Law that relates to (i) its obligations under or activities in connection with this Agreement or (ii) its activities undertaken at, in connection with or relating to Work Locations. AT&T and BellSouth each agree to indemnify, defend, (at the other Party's request) and save harmless the other, each of its officers, directors and employees from and against any losses, damages, claims, demands, suits, liabilities, fines, penalties and expenses (including reasonable attorneys' fees) that arise out of or result from (i) its failure or the failure of its contractors or agents to so comply or (ii) any activity, duty or status of it or its contractors or agents that triggers any legal obligation to investigate or remediate environmental contamination. BellSouth, at its own expense, will be solely responsible for obtaining from governmental authorities, building owners, other carriers, and any other persons or entities, all rights and privileges (including, but not limited to, space and power), which are necessary for BellSouth to provide the Services and Elements pursuant to this Agreement. AT&T, at its own expense, will be solely responsible for obtaining from governmental authorities, building owners, other carriers, and any other persons or entities, all rights and privileges which are AT&T's obligation as a provider of telecommunications services to its Customers pursuant to this Agreement.

7.2 BellSouth shall accept orders for Service and Elements in accordance with the Federal Communications Commission Rules or State Commission Rules.

#### 8. Responsibility For Environmental Contamination

8.1 AT&T shall in no event be liable to BellSouth for any costs whatsoever resulting from the presence or Release of any Environmental Hazard or Hazardous Materials that AT&T did not introduce to the affected Work Location so long as AT&T's actions do not cause or substantially contribute to the release of any Environmental Hazard or Hazardous Materials. BellSouth shall indemnify, defend (at AT&T's request) and hold harmless AT&T, each of its officers, directors and employees from and against any losses, damages, claims, demands, suits, liabilities, fines, penalties, and expenses (including reasonable attorneys' fees) that arise out of or result from (i) any Environmental Hazard or Hazardous Materials that BellSouth, its contractors or agents introduce to the Work Locations or (ii) the presence or Release of any Environmental Hazard or Hazardous Materials for which BellSouth is responsible under Applicable Law, to the extent the release of any Environmental Hazard or Hazardous Materials is not caused or substantially contributed to by AT&T's actions.

8.2 BellSouth shall in no event be liable to AT&T for any costs whatsoever resulting from the presence or Release of any Environmental Hazard or Hazardous Materials that BellSouth did not introduce to the affected Work

location, so long as BellSouth's actions do not cause or substantially contribute to the release of any Environmental Hazard or Hazardous Materials. AT&T shall indemnify (and BellSouth, at BellSouth's request) and hold harmless BellSouth, each of its officers, directors and employees from and against any losses, damages, claims, demands, suits, liabilities, fines, penalties and expenses (including reasonable attorneys' fees) that arise out of or result from (i) any Environmental Hazard or Hazardous Materials that AT&T, its contractors or agents introduce to the Work Locations or (ii) the presence or Release of any Environmental Hazard or Hazardous Materials for which AT&T is responsible under Applicable Law, to the extent the release of any Environmental Hazard or Hazardous Materials is not caused or substantially contributed to by BellSouth's actions.

9. Regulatory Matters

9.1 BellSouth shall be responsible for obtaining and keeping in effect all Federal Communications Commission, State Commissions, franchise authority and other regulatory approvals that may be required in connection with the performance of its obligations under this Agreement. AT&T shall be responsible for obtaining and keeping in effect all Federal Communications Commission, state regulatory Commission, franchise authority and other regulatory approvals that may be required in connection with its offering of services to AT&T Customers contemplated by this Agreement. AT&T shall reasonably cooperate with BellSouth in obtaining and maintaining any required approvals for which BellSouth is responsible, and BellSouth shall reasonably cooperate with AT&T in obtaining and maintaining any required approvals for which AT&T is responsible.

9.2 In the event that BellSouth is required by any governmental authority to file a tariff or make another similar filing ("Filing") in order to implement this Agreement, BellSouth shall (i) consult with AT&T reasonably in advance of such Filing about the form and substance of such Filing, (ii) provide to AT&T its proposed tariff and obtain AT&T's agreement on the form and substance of such Filing, and (iii) take all steps reasonably necessary to ensure that such Filing imposes obligations upon BellSouth that are no less favorable than those provided in this Agreement and preserves for AT&T the full benefit of the rights otherwise provided in this Agreement. In no event shall BellSouth file any tariff to implement this Agreement that purports to govern Services and Elements that is inconsistent with the rates and other terms and conditions set forth in this Agreement unless such rate or other terms and conditions are more favorable than those set forth in this Agreement.

9.3 In the event that any final and nonappealable legislative, regulatory, judicial or other legal action materially affects any material terms of this Agreement, or the ability of AT&T or BellSouth to perform any material terms of this Agreement,

*UB*  
FL6/10/97

AT&T or BellSouth may, on thirty (30) days written notice (delivered not later than thirty (30) days following the date on which such action has become legally binding and has otherwise become final and nonappealable) require that such terms be renegotiated, and the Parties shall renegotiate in good faith such mutually acceptable new terms as may be required. In the event that such new terms are not renegotiated within ninety (90) days after such notice the Dispute shall be referred to the Alternative Dispute Resolution procedures set forth in Attachment 1.

10. **Liability and Indemnity**

- 10.1 **Liabilities of BellSouth** - Unless expressly stated otherwise in this Agreement, the liability of BellSouth to AT&T during any Contract Year resulting from any and all causes shall not exceed the amount due and owing by AT&T to BellSouth during the Contract Year in which such cause arises or accrues.
- 10.2 **Liabilities of AT&T** - Unless expressly stated otherwise in this Agreement, the liability of AT&T to BellSouth during any Contract Year resulting from any and all causes shall not exceed the amount due and owing by AT&T to BellSouth during the Contract Year in which such cause arises or accrues.
- 10.3 Each party shall, to the greatest extent permitted by Applicable Law, include in its local switched service tariff (if it files one in a particular State) or in any State where it does not file a local service tariff, in an appropriate contract with its customers that relates to the Services and Elements provided under this Agreement, a limitation of liability (i) that covers the other Party to the same extent the first Party covers itself and (ii) that limits the amount of damages a customer may recover to the amount charged the applicable customer for the service that gave rise to such loss.
- 10.4 **No Consequential Damages** - NEITHER AT&T NOR BELLSOUTH SHALL BE LIABLE TO THE OTHER PARTY FOR ANY INDIRECT, INCIDENTAL, CONSEQUENTIAL, RELIANCE, OR SPECIAL DAMAGES SUFFERED BY SUCH OTHER PARTY (INCLUDING WITHOUT LIMITATION DAMAGES FOR HARM TO BUSINESS, LOST REVENUES, LOST SAVINGS, OR LOST PROFITS SUFFERED BY SUCH OTHER PARTIES), REGARDLESS OF THE FORM OF ACTION, WHETHER IN CONTRACT, WARRANTY, STRICT LIABILITY, OR TORT, INCLUDING WITHOUT LIMITATION NEGLIGENCE OF ANY KIND WHETHER ACTIVE OR PASSIVE, AND REGARDLESS OF WHETHER THE PARTIES KNEW OF THE POSSIBILITY THAT SUCH DAMAGES COULD RESULT. EACH PARTY HEREBY RELEASES THE OTHER PARTY AND SUCH OTHER PARTY'S SUBSIDIARIES AND AFFILIATES, AND THEIR RESPECTIVE OFFICERS, DIRECTORS, EMPLOYEES AND AGENTS FROM ANY SUCH CLAIM. NOTHING CONTAINED IN THIS SECTION 10 SHALL LIMIT BELLSOUTH'S OR AT&T'S

*MB*

LIABILITY TO THE OTHER FOR (i) WILLFUL OR INTENTIONAL MISCONDUCT (INCLUDING GROSS NEGLIGENCE), (ii) BODILY INJURY, DEATH OR DAMAGE TO TANGIBLE REAL OR TANGIBLE PERSONAL PROPERTY PROXIMATELY CAUSED BY BELLSOUTH'S OR AT&T'S NEGLIGENT ACT OR OMISSION OR THAT OF THEIR RESPECTIVE AGENTS, SUBCONTRACTORS OR EMPLOYEES, NOR SHALL ANYTHING CONTAINED IN THIS SECTION 10 LIMIT THE PARTIES' INDEMNIFICATION OBLIGATIONS AS SPECIFIED HEREIN.

- 10.5 **Obligation to Indemnify** - Each Party shall, and hereby agrees to, defend at the other's request, indemnify and hold harmless the other Party and each of its officers, directors, employees and agents (each, an "Indemnitee") against and in respect of any loss, debt, liability, damage, obligation, claim, demand, judgment or settlement of any nature or kind, known or unknown, liquidated or unliquidated, including without limitation all reasonable costs and expenses incurred (legal, accounting or otherwise) (collectively, "Damages") arising out of, resulting from or based upon any pending or threatened claim, action, proceeding or suit by any third Party (a "Claim") (i) alleging any breach of any representation, warranty or covenant made by such indemnifying Party (the "Indemnifying Party") in this Agreement, (ii) based upon injuries or damage to any person or property or the environment arising out of or in connection with this Agreement that are the result of the Indemnifying Party's actions, breach of Applicable Law, or status of its employees, agents and subcontractors, or (iii) for actual or alleged infringement of any patent, copyright, trademark, service mark, trade name, trade dress, trade secret or any other intellectual property right, now known or later developed (referred to as "Intellectual Property Rights") to the extent that such claim or action arises from AT&T or AT&T's Customer's use of the Services and Elements provided under this Agreement.
- 10.6 **Obligation to Defend; Notice; Cooperation** - Whenever a Claim shall arise for indemnification under this Section 10, the relevant Indemnitee, as appropriate, shall promptly notify the Indemnifying Party and request the Indemnifying Party to defend the same. Failure to so notify the Indemnifying Party shall not relieve the Indemnifying Party of any liability that the Indemnifying Party might have, except to the extent that such failure prejudices the Indemnifying Party's ability to defend such Claim. The Indemnifying Party shall have the right to defend against such liability or assertion in which event the Indemnifying Party shall give written notice to the Indemnitee of acceptance of the defense of such Claim and the identity of counsel selected by the Indemnifying Party. Except as set forth below, such notice to the relevant Indemnitee shall give the Indemnifying Party full authority to defend, adjust, compromise or settle such Claim with respect to which such notice shall have been given, except to the extent that any compromise or settlement shall prejudice the Intellectual Property Rights of the relevant Indemnitees. The

Indemnifying Party shall consult with the relevant Indemnitee prior to any compromise or settlement that would affect the Intellectual Property Rights or other rights of any Indemnitee, and the relevant Indemnitee shall have the right to refuse such compromise or settlement and, at the refusing Party's or refusing Parties' cost, to take over such defense, provided that in such event the Indemnifying Party shall not be responsible for, nor shall it be obligated to indemnify the relevant Indemnitee against, any cost or liability in excess of such refused compromise or settlement. With respect to any defense accepted by the Indemnifying Party, the relevant Indemnitee shall be entitled to participate with the Indemnifying Party in such defense if the Claim requests equitable relief or other relief that could affect the rights of the Indemnitee and also shall be entitled to employ separate counsel for such defense at such Indemnitee's expense. In the event the Indemnifying Party does not accept the defense of any indemnified Claim as provided above, the relevant Indemnitee shall have the right to employ counsel for such defense at the expense of the Indemnifying Party. Each Party agrees to cooperate and to cause its employees and agents to cooperate with the other Party in the defense of any such Claim and the relevant records of each Party shall be available to the other Party with respect to any such defense.

#### 11. Audits and Inspections

- 11.1 For carrier billing purposes, the Parties have agreed pursuant to Section 12 of Attachment 6, to create a process for pre-bill certification. Until such time as that process is in place, the audit process provided in Section 11.1 shall apply.
- 11.1.1 Subject to BellSouth's reasonable security requirements and except as may be otherwise specifically provided in this Agreement, AT&T may audit BellSouth's books, records and other documents once in each Contract Year for the purpose of evaluating the accuracy of BellSouth's billing and invoicing. AT&T may employ other persons or firms for this purpose. Such audit shall take place at a time and place agreed on by the Parties no later than thirty (30) days after notice thereof to BellSouth.
- 11.1.2 BellSouth shall promptly correct any billing error that is revealed in an audit, including making refund of any overpayment by AT&T in the form of a credit on the invoice for the first full billing cycle after the Parties have agreed upon the accuracy of the audit results. Any Disputes concerning audit results shall be resolved pursuant to the Alternate Dispute Resolution procedures described in Section 16 of the General Terms and Conditions and Attachment 1.
- 11.1.3 BellSouth shall cooperate fully in any such audit, providing reasonable access to any and all appropriate BellSouth employees and books, records and other documents reasonably necessary to assess the accuracy of BellSouth's bills.

*MB*  
FL6/10/97



- 11.1.4 AT&T may audit BellSouth's books, records and documents more than once during any Contract Year if the previous audit found previously uncorrected net variances or errors in invoices in BellSouth's favor with an aggregate value of at least two percent (2%) of the amounts payable by AT&T for Services and Elements or Combinations provided during the period covered by the audit.
- 11.1.5 Audits shall be at AT&T's expense, subject to reimbursement by BellSouth in the event that an audit finds an adjustment in the charges or in any invoice paid or payable by AT&T hereunder by an amount that is, on an annualized basis greater than two percent (2%) of the aggregate charges for the Services and Elements during the period covered by the audit.
- 11.1.6 Upon (i) the discovery by BellSouth of overcharges not previously reimbursed to AT&T or (ii) the resolution of disputed audits, BellSouth shall promptly reimburse AT&T the amount of any overpayment times the highest interest rate (in decimal value) which may be levied by law for commercial transactions, compounded daily for the number of days from the date of overpayment to and including the date that payment is actually made. In no event, however, shall interest be assessed on any previously assessed or accrued late payment charges.
- 11.2 Subject to reasonable security requirements, either Party may audit the books, records and other documents of the other for the purpose of evaluating usage pertaining to transport and termination of local traffic. Where such usage data is being transmitted through CABS, the audit shall be conducted in accordance with CABS or other applicable requirements approved by the appropriate State Commission. If data is not being transferred via CABS, either Party may request an audit for such purpose once each Contract Year. Either Party may employ other persons or firms for this purpose. Any such audit shall take place no later than thirty (30) days after notice thereof to the other Party.
- 11.2.1 Either Party shall promptly correct any reported usage error that is revealed in an audit, including making payment of any underpayment after the Parties have agreed upon the accuracy of the audit results. Any Disputes concerning audit results shall be resolved pursuant to the Alternate Dispute Resolution procedures described in Section 16 of the General Terms and Conditions and Attachment 1.
- 11.2.2 The Parties shall cooperate fully in any such audit, providing reasonable access to any and all appropriate employees and books, records and other documents reasonably necessary to assess the usage pertaining to transport and terminating of local traffic.

12 Performance Measurement

12.1 In providing Services and Elements, BellSouth will provide AT&T with the quality of service BellSouth provides itself and its end-users. BellSouth's performance under this Agreement shall provide AT&T with the capability to meet standards or other measurements that are at least equal to the level that BellSouth provides or is required to provide by law or its own internal procedures. BellSouth shall satisfy all service standards, measurements, and performance requirements set forth in the Agreement and the Direct Measures of Quality ("DMOQs") that are specified in Attachment 12 of this Agreement. In the event that BellSouth demonstrates that the level of performance specified in Attachment 12 of this Agreement are higher than the standards or measurements that BellSouth provides to itself and its end users pursuant to its own internal procedures, BellSouth's own level of performance shall apply.

12.2 The Parties acknowledge that the need will arise for changes to the DMOQ's specified in Attachment 12 during the term of this Agreement. Such changes may include the addition or deletion of measurements or a change in the performance standard for any particular metric. The parties agree to review all DMOQ's on a quarterly basis to determine if any changes are appropriate.

12.3 The Parties agree to monitor actual performance on a monthly basis and develop a Process Improvement Plan to continually improve quality of service provided as measured by the DMOQs.

13. **DELETED**

14. Force Majeure

14.1 Neither Party shall be liable for any delay or failure in performance of any part of this Agreement caused by a Force Majeure condition, including acts of the United States of America or any state, territory or political subdivision thereof, acts of God or a public enemy, fires, floods, disputes, freight embargoes, strikes, earthquakes, volcanic actions, wars, civil disturbances, or other causes beyond the reasonable control of the Party claiming excusable delay or other failure to perform. Force Majeure shall not include acts of any Governmental Authority relating to environmental, health or safety conditions at Work Locations. If any Force Majeure condition occurs, the Party whose performance fails or is delayed because of such Force Majeure condition shall give prompt notice to the other Party, and upon cessation of such Force Majeure condition, shall give like notice and commence performance hereunder as promptly as reasonably practicable.

14.2 Notwithstanding Subsection 1, no delay or other failure to perform shall be excused pursuant to this Section 14 by the acts or omission of a Party's

  
FL6/10/97

subcontractors, material persons, suppliers or other third persons providing products or services to such Party unless: (i) such acts or omissions are themselves the product of a Force Majeure condition; (ii) such acts or omissions do not relate to environmental, health or safety conditions at Work Locations; and, (iii) unless such delay or failure and the consequences thereof are beyond the control and without the fault or negligence of the Party claiming excusable delay or other failure to perform. Notwithstanding the foregoing, this Section 14 shall not excuse failure or delays where BellSouth is required to implement Disaster Recovery plans to avoid such failures and delays in performance.

15. **Certain Federal, State and Local Taxes**

15.1 **Definition** For purposes of this Section 15, the terms "taxes" and "fees" shall include but not be limited to federal, state or local sales, use, excise, gross receipts or other taxes or tax-like fees of whatever nature and however designated (including tariff surcharges and any fees, charges or other payments, contractual or otherwise, for the use of public streets or rights of way, whether designated as franchise fees or otherwise) imposed on, or sought to be imposed, either of the parties and measured by the charges or payments, for the services furnished hereunder, excluding any taxes levied on income.

15.2 **Taxes And Fees Imposed Directly On Either Seller Or Purchaser**

15.2.1 Taxes and fees imposed on the providing Party, which are neither permitted nor required to be passed on by the providing Party to its Customer, shall be borne and paid by the providing Party.

15.2.2 Taxes and fees imposed on the purchasing Party, which are not required to be collected and/or remitted by the providing Party, shall be borne and paid by the purchasing Party.

15.3 **Taxes And Fees Imposed On Purchaser But Collected And Remitted By Seller**

15.3.1 Taxes and fees imposed on the purchasing Party shall be borne by the purchasing Party, even if the obligation to collect and/or remit such taxes or fees is placed on the providing Party.

15.3.2 To the extent permitted by Applicable Law, any such taxes and/or fees shall be shown as separate items on applicable billing documents between the Parties. Notwithstanding the foregoing, the purchasing Party shall remain liable for any such taxes and fees regardless of whether they are actually billed by the providing Party at the time that the respective service is billed.

  
FL5/10/97

- 15.3.3 If the purchasing Party determines that in its opinion any such taxes or fees are not lawfully due, the providing Party shall not bill such taxes or fees to the purchasing Party if the purchasing Party provides written certification reasonably satisfactory to the providing Party, stating that it is exempt or otherwise not subject to the tax or fee, setting forth the basis therefor, and satisfying any other requirements under applicable law. If any authority seeks to collect any such tax or fee that the purchasing Party has determined and certified not to be lawfully due, or any such tax or fee that was not billed by the providing Party, the purchasing Party may contest the same in good faith, at its own expense. In the event that such contest must be pursued in the name of the providing Party, the providing Party shall permit the purchasing Party to pursue the contest in the name of providing Party and providing Party shall have the opportunity to participate fully in the preparation of such contest. In any such contest, the purchasing Party shall promptly furnish the providing Party with copies of all filings in any proceeding, protest, or legal challenge, all rulings issued in connection therewith, and all correspondence between the purchasing Party and the taxing authority.
- 15.3.4 In the event that all or any portion of an amount sought to be collected must be paid in order to contest the imposition of any such tax or fee, or to avoid the existence of a lien on the assets of the providing Party during the pendency or such contest, the purchasing Party shall be responsible for such payment and shall be entitled to the benefit of any refund or recovery.
- 15.3.5 If it is ultimately determined that any additional amount of such a tax or fee is due to the imposing authority, the purchasing Party shall pay such additional amount, including any interest and penalties thereon.
- 15.3.6 Notwithstanding any provision to the contrary, the purchasing Party shall protect, indemnify and hold harmless (and defend at the purchasing Party's expense) the providing Party from and against any such tax or fee, interest or penalties thereof, or other charges or payable expenses (including reasonable attorney fees) with respect thereto, which are reasonably and necessarily incurred by the providing Party in connection with any claim for or contest of any such tax or fee.
- 15.3.7 Each Party shall notify the other Party in writing of any assessment, proposed assessment or other claim for any additional amount of such a tax or fee by a taxing authority; such notice to be provided, if possible, at least ten (10) days prior to the date by which a response, protest or other appeal must be filed, but in no event later than thirty (30) days after receipt of such assessment, proposed assessment or claim.
- 15.4 **Taxes And Fees Imposed On Seller But Passed On To Purchaser**

- 15.4.1 Taxes and fees imposed on the providing Party which are permitted or required to be passed on by the providing Party to its Customer shall be borne by the purchasing Party.
- 15.4.2 To the extent permitted by applicable law, any such taxes and/or fees shall be shown as separate items on applicable billing documents between the Parties. Notwithstanding the foregoing, the purchasing Party shall remain liable for any such taxes and fees regardless of whether they are actually billed by the providing Party at the time that the respective service is billed.
- 15.4.3 If the purchasing Party disagrees with the providing Party's determination as to the application or basis for any such tax or fee, the Parties shall consult with respect to the imposition and billing of such tax or fee and with respect to whether to contest the imposition of such tax or fee. Notwithstanding the foregoing, the providing Party shall retain responsibility for determining whether and to what extent any such taxes or fees are applicable. The providing Party shall further retain responsibility for determining whether and how to contest the imposition of such taxes or fees, provided, however, the Parties agree to consult in good faith as to such contest and that any such contest undertaken at the request of the purchasing Party shall be at the purchasing Party's expense. In the event that such contest must be pursued in the name of the providing Party, providing Party shall permit purchasing Party to pursue the contest in the name of the providing Party and the providing Party shall have the opportunity to participate fully in the preparation of such contest.
- 15.4.4 If, after consultation in accordance with the preceding Section 15.4.3, the purchasing Party does not agree with the providing Party's final determination as to the application or basis of a particular tax or fee, and if the providing Party, after receipt of a written request by the purchasing Party to contest the imposition of such tax or fee with the imposing authority, fails or refuses to pursue such contest or to allow such contest by the purchasing Party, the purchasing Party may utilize the dispute resolution process outlined in Section 16 of the General Terms and Conditions of this Agreement and Attachment 1. Utilization of the dispute resolution process shall not relieve the purchasing party from liability for any tax or fee billed by the providing Party pursuant to this subsection during the pendency of such dispute resolution proceeding. In the event that the purchasing Party prevails in such dispute resolution proceeding, it shall be entitled to a refund in accordance with the final decision therein. Notwithstanding the foregoing, if at any time prior to a final decision in such dispute resolution proceeding the providing Party initiates a contest with the imposing authority with respect to any of the issues involved in such dispute resolution proceeding, the dispute resolution proceeding shall be dismissed as to such common issues and the final decision rendered in the contest with the imposing authority shall control as to such issues.

- 15.4.5 In the event that all or any portion of an amount sought to be collected must be paid in order to contest the imposition of any such tax or fee with the imposing authority, or to avoid the existence of a lien on the assets of the providing Party during the pendency of such contest, the purchasing Party shall be responsible for such payment and shall be entitled to the benefit of any refund or recovery.
- 15.4.6 If it is ultimately determined that any additional amount of such a tax or fee is due to the imposing authority, the purchasing Party shall pay such additional amount, including any interest and penalties thereon.
- 15.4.7 Notwithstanding any provision to the contrary, the purchasing Party shall protect, indemnify and hold harmless (and defend at the purchasing Party's expense) the providing Party from and against any such tax or fee, interest or penalties thereon, or other reasonable charges or payable expenses (including reasonable attorney fees) with respect thereto, which are incurred by the providing Party in connection with any claim for or contest of any such tax or fee.
- 15.4.8 Each Party shall notify the other Party in writing of any assessment, proposed assessment or other claim for any additional amount of such a tax or fee by a taxing authority, such notice to be provided, if possible, at least ten (10) days prior to the date by which a response, protest or other appeal must be filed, but in no event later than thirty (30) days after receipt of such assessment, proposed assessment or claim.

#### 15.5 Mutual Cooperation

In any contest of a tax or fee by one Party, the other Party shall cooperate fully by providing records, testimony and such additional information or assistance as may reasonably be necessary to pursue the contest. Further, the other Party shall be reimbursed for any reasonable and necessary out-of-pocket copying and travel expenses incurred in assisting in such contest. Each Party agrees to indemnify and hold harmless the other Party from and against any losses, damages, claims, demands, suits, liabilities, and expenses, including reasonable attorney's fees, that arise out of its failure to perform its obligations under this Section.

#### 16. Alternative Dispute Resolution

- 16.1 All disputes, claims or disagreements (collectively "Disputes") arising under or related to this Agreement or the breach hereof shall be resolved in accordance with the procedures set forth in Attachment 1, except: (i) disputes arising pursuant to Attachment 6, Connectivity Billing; and (ii) disputes or matters for which the Telecommunications Act of 1996 specifies a particular remedy or procedure. Disputes involving matters subject to the Connectivity Billing

provisions contained in Attachment 6 shall be resolved in accordance with the Billing Disputes section of Attachment 6. In no event shall the Parties permit the pendency of a Dispute to disrupt service to any AT&T Customer contemplated by this Agreement. The foregoing notwithstanding, neither this Section nor Attachment 1 shall be construed to prevent either Party from seeking and obtaining temporary equitable remedies, including temporary restraining orders. A request by a Party to a court or a regulatory authority for interim measures or equitable relief shall not be deemed a waiver of the obligation to comply with Attachment 1.

17

### Notices

Any notices or other communications required or permitted to be given or delivered under this Agreement shall be in hard-copy writing (unless otherwise specifically provided herein) and shall be sufficiently given if delivered personally or delivered by prepaid overnight express service to the following (unless otherwise specifically required by this Agreement to be delivered to another representative or point of contact):

If to AT&T:

Pamela A. Nelson  
Vendor Management  
AT&T  
1200 Peachtree St., N.E.  
Atlanta, GA 30309

If to BellSouth:

Randy Jenkins  
Interconnection Services  
Suite 410  
1960 W. Exchange Place  
Tucker, GA 30084

Either Party may unilaterally change its designated representative and/or address for the receipt of notices by giving seven (7) days prior written notice to the other Party in compliance with this Section. Any notice or other communication shall be deemed given when received.

18.

### Confidentiality and Proprietary Information

18.1

For the purposes of this Agreement, "Confidential Information" means confidential or proprietary technical or business information given by the Discloser to the Recipient. All information which is disclosed by one Party to the other in connection with this Agreement shall automatically be deemed proprietary to the Discloser and subject to this Agreement, unless otherwise

confirmed in writing by the Discloser. In addition, by way of example and not limitation, all orders for Services and Elements placed by AT&T pursuant to this Agreement, and information that would constitute Customer Proprietary Network pursuant to the Act and the rules and regulations of the Federal Communications Commission, and Recorded Usage Data as described in Attachment 7 whether disclosed by AT&T to BellSouth or otherwise acquired by BellSouth in the course of the performance of this Agreement, shall be deemed Confidential Information of AT&T for all purposes under this Agreement.

- 18.2 For a period of five (5) years from the receipt of Confidential Information from the Discloser, except as otherwise specified in this Agreement, the Recipient agrees (a) to use it only for the purpose of performing under this Agreement, (b) to hold it in confidence and disclose it to no one other than its employees having a need to know for the purpose of performing under this Agreement, and (c) to safeguard it from unauthorized use or disclosure with at least the same degree of care with which the Recipient safeguards its own Confidential Information. If the Recipient wishes to disclose the Discloser's Confidential Information to a third Party agent or consultant, the agent or consultant must have executed a written agreement of non-disclosure and non-use comparable in scope to the terms of this Section.
- 18.3 The Recipient may make copies of Confidential Information only as reasonably necessary to perform its obligations under this Agreement. All such copies shall bear the same copyright and proprietary rights notices as are contained on the original.
- 18.4 The Recipient agrees to return all Confidential Information in tangible form received from the Discloser, including any copies made by the Recipient, within thirty (30) days after a written request is delivered to the Recipient, or to destroy all such Confidential Information, except for Confidential Information that the Recipient reasonably requires to perform its obligations under this Agreement. If either Party loses or makes an unauthorized disclosure of the other Party's Confidential Information, it shall notify such other Party immediately and use reasonable efforts to retrieve the lost or wrongfully disclosed information.
- 18.5 The Recipient shall have no obligation to safeguard Confidential Information: (a) which was in the possession of the Recipient free of restriction prior to its receipt from the Discloser; (b) after it becomes publicly known or available through no breach of this Agreement by the Recipient; (c) after it is rightfully acquired by the Recipient free of restrictions on its disclosure; or (d) after it is independently developed by personnel of the Recipient to whom the Discloser's Confidential Information had not been previously disclosed. In addition, either Party shall have the right to disclose Confidential Information to

  
FL6/10/97



any mediator, arbitrator, state or federal regulatory body, the Department of Justice or any court in the conduct of any mediation, arbitration or approval of this Agreement or in any proceedings concerning the provision of InterLATA services by BellSouth that are or may be required by the Act. Additionally, the Recipient may disclose Confidential Information if so required by law, a court or governmental agency, so long as the Discloser has been notified of the requirement promptly after the Recipient becomes aware of the requirement. In all cases, the Recipient must undertake all lawful measures to avoid disclosing such information until Discloser has had reasonable time to seek and comply with a protective order that covers the Confidential Information to be disclosed.

18.6 Each Party's obligations to safeguard Confidential Information disclosed prior to expiration or termination of this Agreement shall survive such expiration or termination.

18.7 Except as otherwise expressly provided elsewhere in this Agreement, no license is hereby granted under any patent, trademark, or copyright, nor is any such license implied, solely by virtue of the disclosure of any Confidential Information.

18.8 Each Party agrees that the Discloser would be irreparably injured by a breach of this Agreement by the Recipient or its representatives and that the Discloser shall be entitled to seek equitable relief, including injunctive relief and specific performance, in the event of any breach of the provisions of this Agreement. Such remedies shall not be deemed to be the exclusive remedies for a breach of this Agreement, but shall be in addition to all other remedies available at law or in equity.

19 **Branding**

The Parties agree that the services offered by AT&T that incorporate Services and Elements made available to AT&T pursuant to this Agreement shall be branded as AT&T services, unless BellSouth determines to unbrand such Services and Elements for itself, in which event BellSouth may provide unbranded Services and Elements. AT&T shall provide the exclusive interface to AT&T Customers, except as AT&T shall otherwise specify. In those instances where AT&T requires BellSouth personnel or systems to interface with AT&T Customers, such personnel shall identify themselves as representing AT&T, and shall not identify themselves as representing BellSouth. Except for material provided by AT&T, all forms, business cards or other business materials furnished by BellSouth to AT&T Customers shall be subject to AT&T's prior review and approval. In no event shall BellSouth, acting on behalf of AT&T pursuant to this Agreement, provide information to AT&T local service Customers about BellSouth products or services. BellSouth

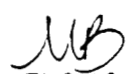
  
FL6710/97

agrees to provide in sufficient time for AT&T to review and provide comments the methods and procedures, training and approaches, to be used by BellSouth to assure that BellSouth meets AT&T's branding requirement. For installation and repair services, AT&T agrees to provide BellSouth with branded material at no charge for use by BellSouth ("Leave Behind Material"). AT&T will reimburse BellSouth for the reasonable and demonstrable costs BellSouth would otherwise incur as a result of the use of the generic leave behind material. BellSouth will notify AT&T of material supply exhaust in sufficient time that material will always be available. BellSouth may leave a generic card if BellSouth does not have an AT&T specific card available. BellSouth will not be liable for any error, mistake or omission, other than intentional acts or omissions or gross negligence, resulting from the requirements to distribute AT&T's Leave Behind Material.

20. **Directory Listings Requirements**

20.1 BellSouth shall make available to AT&T, for AT&T subscribers, non-discriminatory access to its telephone number and address directory listings ("Directory Listings"), under the below terms and conditions. In no event shall AT&T subscribers receive Directory Listings that are at less favorable rates, terms or conditions than the rates, terms or conditions that BellSouth provides its subscribers.

20.1.1 **DELETED**

20.1.2 **DELETED**

20.1.3 Subject to execution of an Agreement between AT&T and BellSouth's affiliate, BellSouth Advertising & Publishing Corporation ("BAPCO") substantially in the form set forth in Attachment 13: (1) listings shall be included in the appropriate White Pages or local alphabetical directories (including Foreign Language directories as appropriate), via the BellSouth ordering process, (basic listing shall be at no charge to AT&T or AT&T's subscribers); (2) AT&T's business subscribers' listings shall also be included in the appropriate Yellow Pages or local classified directories, via the BellSouth ordering process, at no charge to AT&T or AT&T's subscribers; (3) copies of such directories shall be delivered by BAPCO to AT&T's subscribers; (4) AT&T will sell enhanced White Pages Listings to AT&T subscribers and BellSouth shall provide the enhanced White Listings; and (5) Yellow Pages Advertising will be sold and billed to AT&T subscribers.

20.1.4 BAPCO will provide AT&T the necessary publishing information to process AT&T's subscribers directory listings requests including, but not limited to:

1. Classified Heading Information

- 2. Telephone Directory Coverage Areas by NPA, NXX
- 3. Publishing Schedules
- 4. Processes for Obtaining Foreign Directories
- 5. Information about Listing AT&T's Customer Services, including telephone numbers, in the Customer Call Guide Pages.

20.2 BellSouth will provide AT&T the proper format for submitting subscriber information as outlined in the OLEC Handbook. BellSouth and BAPCO will accord a directory listing information the same level of confidentiality that BellSouth and BAPCO accord BellSouth's and BAPCO'S own directory listing information. BellSouth shall limit access to AT&T's Customer proprietary, confidential directory information to those BellSouth or BAPCO employees who are involved in the preparation of listings.

20.3 BellSouth will include AT&T subscriber listings in BellSouth's directory assistance databases and BellSouth will not charge AT&T to maintain the Directory Assistance database. The Parties agree to cooperate with each other in formulating appropriate procedures regarding lead time, timeline, format, and content of listing information.

20.4 **DELETED**

21. **Subscriber List Information/Local Number Portability**

21.1 **DELETED**

21.2 BellSouth shall refer any requests from third parties for AT&T's Subscriber Information to AT&T.

21.3 Local Number Portability shall be provided as set forth in Attachment 8

21.A **Insurance Requirements**

At all times during the term of this Agreement, each Party shall maintain, at its own expense, (i) all insurance required by applicable Law including insurances and approved self insurance for statutory workers compensation coverage and (ii) commercial general liability coverage in the amount of not less than ten million dollars (\$10,000,000) or a combination of commercial general liability and excess/umbrella coverage totaling ten million dollars (\$10,000,000). Upon request from the other Party, each Party shall furnish the other Party with certificates of insurance which evidence the minimum levels of insurance set forth herein. Each Party may satisfy all or part of the coverage specified herein through self insurance. Each Party shall give the other Party at least 30 days

*MB*

days advance written notice of any cancellation or non-renewal of insurance required by this Section.

**21 B Costs**

Except as otherwise specified in this Agreement, the Act, or any Commission order, each Party shall be responsible for all costs and expenses that it incurs to comply with its obligations under this Agreement.

**21.B.1 DELETED**

**21 C Pre-Ordering Information**

**21.C.1** BellSouth shall provide AT&T with access on a real-time basis via electronic interfaces to all services and features technically available from each switch, by switch CLLI and access to street address detail for the provisioning of a service request. This information is currently contained in BellSouth's Regional Street Address Guide ("RSAG") and Products and Services Inventory Management (P/SIMS).

**21.C.2** If AT&T dials in, AT&T will obtain from BellSouth a security card featuring a unique password identification which will be changed periodically by BellSouth. A nonrecurring charge of One Hundred (\$100.00) Dollars will be applied to each security card provided, including duplicates furnished to additional users or furnished as a replacement of lost or stolen cards.

**21.C.3** AT&T acknowledges that (i) this information is provided for the limited purposes of facilitating the establishment of new Customer accounts and identifying services and features available in specific BellSouth central offices. AT&T agrees that it will not sell or otherwise transfer such information to any third Party for any purpose whatsoever without the prior written consent of BellSouth; (ii) BellSouth does not warrant that services provided under this Section will be uninterrupted or error-free. In the event of interruptions, delays, errors or other failure of the services, BellSouth's obligation shall be limited to using reasonable efforts under the circumstances to restore the services. BellSouth shall have no obligation to retrieve or reconstruct any transmitted messages or transmission data which may be lost or damaged. AT&T is responsible for providing back-up for data deemed by BellSouth to be necessary to its operations; (iii) the services provided under this Section are provided "As Is." BellSouth makes no warranty, express or implied, with respect to the services, including but not limited to any warranty of merchantability or fitness for a particular purpose, which warranties are hereby expressly disclaimed.

**21 D Disaster Recovery**

  
FL6/10/97

BellSouth and AT&T agree to jointly develop and implement a detailed service restoration plan and disaster recovery plan to be in effect by December 31, 1997. A joint task team will commence development no later than November 1, 1996, for implementation throughout 1997 reaching full deployment by December 31, 1997.

Such plans shall incorporate BellSouth Emergency Contingency Plans for Residence and Business Repair Centers. The Plans shall conform to the FCC Restoration Guidelines, to the National Security Emergency Preparedness ("NSEP") procedures and adhere to the guidelines developed by the Telecommunications Service Priority ("TSP") System office within the National Communications System ("NCS") Agency.

In developing the plans, the team will address the following AT&T proposed terms: (i) provision for immediate notification to AT&T via the Electronic Interface, to be established pursuant to Section 3 of Attachment 6 of the Agreement, of the existence, location, and source of any emergency network outage affecting AT&T Customers; (ii) establishment of a single point of contact responsible for initiating and coordinating the restoration of all Local Services and Network Elements or Combinations; (iii) establishment of procedures to provide AT&T with real-time access to information relating to the status of restoration efforts and problem resolution during the restoration process; (iv) provision of an inventory and description of mobile restoration equipment by locations; (v) establishment of methods and procedures for the dispatch of mobile equipment to the restoration site; (vi) establishment of methods and procedures for re-provisioning all Services and Elements, after initial restoration; (vii) provision for equal priority, as between AT&T Customers and BellSouth Customers, for restoration efforts, consistent with FCC Service Restoration guidelines, including, but not limited to, deployment of repair personnel and access to spare parts and components; and (viii) establishment of a mutually agreeable process for escalation of maintenance problems, including a complete, up-to-date list of responsible contacts, available twenty-four (24) hours per day, seven (7) days per week.

Such plans shall be modified and updated as necessary. For purposes of this Section, an emergency network outage is defined as 5,000 or more blocked call attempts in a ten (10) minute period in a single exchange.

In the event the Parties are unable to reach agreement on either plan, the matter shall be resolved pursuant to Section 16 and Attachment 1 of this Agreement.

22. Miscellaneous
- 22.1 Delegation or Assignment

*MB*  
FLS/10/97

BellSouth may not assign any of its rights or delegate any of its obligations under this Agreement without the prior written consent of AT&T which will not be unreasonably withheld. Notwithstanding the foregoing, BellSouth may assign its rights and benefits and delegate its duties and obligations under this Agreement without the consent of AT&T to a 100 percent owned Affiliate company of BellSouth if such Affiliate provides wireline communications provided that the performance of any such assignee is guaranteed by the assignor. Any prohibited assignment or delegations shall be null and void.

## 22.2 Subcontracting

If any Party's obligation under this Agreement is performed by a subcontractor or Affiliate, the Party subcontracting the obligation nevertheless shall remain fully responsible for the performance of this Agreement in accordance with its terms, and shall be solely responsible for payments due its subcontractors or Affiliate. In entering into any contract, subcontract or other agreement for the performance of any obligation under this Agreement, the Party shall not enter into any agreement that it would not enter into if the supplier was performing services directly for said Party.

## 22.3 Nonexclusive Remedies

Except as otherwise expressly provided in this Agreement, each of the remedies provided under this Agreement is cumulative and is in addition to any remedies that may be available at law or in equity.

## 22.4 No Third-Party Beneficiaries

Except as may be specifically set forth in this Agreement, this Agreement does not provide and shall not be construed to provide third Parties with any remedy, claim, liability, reimbursement, cause of action, or other privilege.

## 22.5 Referenced Documents

Whenever any provision of this Agreement refers to a technical reference, technical publication, AT&T Practice, BellSouth Practice, any publication of telecommunications industry administrative or technical standards, or any other document specifically incorporated into this Agreement, it will be deemed to be a reference to the most recent version or edition (including any amendments, supplements, addenda, or successors) of such document that is in effect, and will include the most recent version or edition (including any amendments, supplements, addenda, or successors) of each document incorporated by reference in such a technical reference, technical publication, AT&T Practice, BellSouth Practice, or publication of industry standards (unless AT&T elects otherwise). Should there be an inconsistency between or among publications

  
FL6/10/97

or standards, the Parties shall mutually agree upon which requirement shall apply. If the Parties cannot reach agreement, the matter shall be handled pursuant to Attachment 1 of this Agreement.

**22.6 Applicable Law**

The validity of this Agreement, the construction and enforcement of its terms, and the interpretation of the rights and duties of the Parties shall be governed by the laws of the State of Florida other than as to conflicts of laws, except insofar as federal law may control any aspect of this Agreement, in which case federal law shall govern such aspect. The Parties submit to personal jurisdiction in Atlanta, Georgia, and waive any objections to a Georgia venue

**22.7 Publicity and Advertising**

Neither Party shall publish or use any advertising, sales promotions or other publicity materials that use the other Party's logo, trademarks or service marks without the prior written approval of the other Party.

**22.8 Amendments or Waivers**

Except as otherwise provided in this Agreement, no amendment or waiver of any provision of this Agreement, and no consent to any default under this Agreement, shall be effective unless the same is in writing and signed by an officer of the Party against whom such amendment, waiver or consent is claimed. In addition, no course of dealing or failure of a Party strictly to enforce any term, right or condition of this Agreement shall be construed as a waiver of such term, right or condition.

**22.9 Severability**

If any term, condition or provision of this Agreement is held to be invalid or unenforceable for any reason, such invalidity or unenforceability shall not invalidate the entire Agreement, unless such construction would be unreasonable. The Agreement shall be construed as if it did not contain the invalid or unenforceable provision or provisions, and the rights and obligations of each Party shall be construed and enforced accordingly; provided, however, that in the event such invalid or unenforceable provision or provisions are essential elements of this Agreement and substantially impair the rights or obligations of either Party, the Parties shall promptly negotiate a replacement provision or provisions.

**22.10 Entire Agreement**

This Agreement, which shall include the Attachments, Appendices and other documents referenced herein, constitutes the entire Agreement between the

  
FL6710-97

Parties concerning the subject matter hereof and supersedes any prior agreements, representations, statements, negotiations, understandings, proposals or undertakings, oral or written, with respect to the subject matter expressly set forth herein.

**22.11 Survival of Obligations**

Any liabilities or obligations of a Party for acts or omissions prior to the cancellation or termination of this Agreement, any obligation of a Party under the provisions regarding indemnification, Confidential Information, limitations on liability, and any other provisions of this Agreement which, by their terms, are contemplated to survive (or to be performed after) termination of this Agreement, shall survive cancellation or termination thereof.

**22.12 Executed in Counterparts**

This Agreement may be executed in any number of counterparts, each of which shall be deemed an original; but such counterparts shall together constitute one and the same instrument.

**22.13 Headings of No Force or Effect**

The headings of Articles and Sections of this Agreement are for convenience of reference only, and shall in no way define, modify or restrict the meaning or interpretation of the terms or provisions of this Agreement.

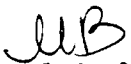
  
FL6/10/97



Part I: Local Services Resale

23            Telecommunications Services Provided for Resale

23.1           At the request of AT&T and pursuant to the requirements of the Act, BellSouth will make available to AT&T for resale (see Section 24.3 of Part 1) any Telecommunications Service that BellSouth currently provides, or may offer hereafter. BellSouth shall also provide Support Functions and Service Functions, as set forth in Sections 27 and 28 of this Part. The Telecommunications Services, Service Functions and Support Functions provided by BellSouth to AT&T pursuant to this Agreement are collectively referred to as "Local Service."

23.2           This Part describes several services which BellSouth shall make available to AT&T for resale pursuant to this Agreement. This list of services is neither all inclusive nor exclusive. All Telecommunications Services of BellSouth which are to be offered for resale pursuant to the Act are subject to the terms herein, even though they are not specifically enumerated or described.

23.2.1        **Features and Functions Subject to Resale**

BellSouth agrees to make available for resale all features and functions available in connection with Telecommunications Services, including but not limited to the following:

- Dial tone and ring
- Capability for either dial pulse or touch tone recognition
- Capability to complete calls to any location
- Same extended local calling area
- 1+ IntraLATA toll calling
- PIC 1+ service
- CIC dialing (10 XXXX)
- Same access to vertical features and functions
- Call detail recording capability required for end user billing
- Flat and Measured Service
- International Calling
- 911, 500, 700, 800, 888, 900, 976 dialing
- Ringling
- Repeat dial capability
- Multi-line hunting
- PBX trunks and DID service

23.3           BellSouth will provide AT&T with at least the capability to provide an AT&T Customer the same experience as BellSouth provides its own Customers with respect to all Local Services. The capability provided to AT&T by BellSouth shall be in accordance with standards or other measurements that are at least

*LB*  
FL6/10/97

equal to the level that BellSouth provides or is required to provide by law and its own internal procedures

24 **General Terms and Conditions for Resale**

24.1 **Primary Local Exchange Carrier Selection**

BellSouth shall apply the principles set forth in Section 64.1100 of the Federal Communications Commission Rules, 47 C.F.R. §64.1100, to the process for end-user selection of a primary local exchange carrier. BellSouth shall not require a disconnect order from the Customer, another carrier, or another entity, in order to process an AT&T order for Local Service for a Customer

24.2 **Pricing**

The prices charged to AT&T for Local Service are set forth in Part IV of this Agreement.

24.3 **Restrictions on Resale**

With the exception of short-term promotions, defined as those promotions that are offered for a ninety (90) day period or less and which are not offered on a consecutive basis, BellSouth shall offer for resale at wholesale prices all telecommunications services that BellSouth provides at retail to non-telecommunications carriers, including governmental bodies and information providers. Short-term promotions may be resold at the retail rate. Long term promotions, defined as those promotions that are offered for more than a ninety (90) day period, may be resold at the tariff rate less the wholesale discount.

No terms and conditions, including use and user restrictions, shall be applicable to the resale of BellSouth's telecommunications services except for:

- (i) a restriction on the resale of residential service to residential customers;
- (ii) LifeLine/Link-up services shall be available for resale by AT&T only to those customers who are eligible to purchase such service directly from BellSouth;
- (iii) All grandfathered services are available for resale by AT&T to those customers or subscribers who already have grandfathered status; and
- (iv) N11/E911/911 services shall be available for resale by AT&T.

  
FLS/10/97

24.3.1 **Dialing Parity**

24.3.1.1 BellSouth agrees that AT&T Customers will experience the same dialing parity as BellSouth's Customers, such that, for all call types: (i) an AT&T Customer is not required to dial any greater number of digits than a BellSouth Customer; the post-dial delay (time elapsed between the last digit dialed and the first network response), call completion rate and transmission quality experienced by an AT&T Customer is at least equal in quality to that experienced by a BellSouth Customer; and (iii) the AT&T Customer may retain its local telephone number.

24.3.2 **Changes in Retail Service**

24.3.2.1 BellSouth agrees to notify AT&T electronically of any changes in the terms and conditions under which it offers Telecommunications Services to subscribers who are non-telecommunications carriers, including, but not limited to, the introduction or discontinuance of any features, functions, services or promotions, at least forty-five (45) days prior to the effective date of any such change or concurrent with BellSouth's internal notification process for such change, whichever is earlier. AT&T recognizes that certain revisions may occur between the time BellSouth notifies AT&T of a change pursuant to this Section and BellSouth's tariff filing of such change. BellSouth shall notify AT&T of such revisions consistent with BellSouth's internal notification process but AT&T accepts the consequences of such mid-stream changes as an uncertainty of doing business and, therefore, will not hold BellSouth responsible for any resulting inconvenience or cost incurred by AT&T unless caused by the intentional misconduct of BellSouth for the purposes of this section. The notification given pursuant to this Section will not be used by either party to market its offering of such changed services externally in advance of BellSouth filing of any such changes.

24.3.2.2 BellSouth agrees to notify AT&T electronically of proposed price changes at least thirty (30) days prior to the effective date of any such price change.

24.3.2.3 BellSouth agrees to use electronic mail to notify AT&T of any operational changes within at least six (6) months before such changes are proposed to become effective and within twelve months for any technological changes. If such operational or technological changes occur within the six or twelve month notification period, BellSouth will notify AT&T of the changes concurrent with BellSouth's internal notification process for such changes.

25. **Requirements for Specific Services**

25.1 **CENTREX Requirements**

  
FL6/10/97

At AT&T's option, AT&T may purchase CENTREX services. Where AT&T purchases such CENTREX services, AT&T may purchase the entire set of features, any single feature, or any combination of features which BellSouth has the capability to provide. BellSouth will provide AT&T with the same service levels and features of CENTREX Service provided by BellSouth to its end users. Requests by AT&T for CENTREX Service levels and features that are different from what BellSouth provides to its end users will be handled under the Bona Fide Request Process. The CENTREX service provided for resale will meet the following requirements:

- 25.1.1 All features and functions of CENTREX Service, whether offered under tariff or otherwise, shall be available to AT&T for resale, without any geographic or Customer class restrictions.
- 25.1.2 BellSouth's CENTREX Service may be used by AT&T to provide Local Service to AT&T's end users.
- 25.1.3 BellSouth shall provide to AT&T a list which describes all CENTREX features and functions offered by BellSouth within ten (10) days of the Effective Date, and shall provide updates to said list as required by Section 24.3.2 of Part 1.
- 25.1.4 **DELETED**
- 25.1.5 AT&T may aggregate the CENTREX local exchange and IntraLATA traffic usage of AT&T Customers to qualify for volume discounts on the basis of such aggregated usage.
- 25.1.6 AT&T may aggregate multiple AT&T Customers on dedicated access facilities. AT&T may require that BellSouth suppress the need for AT&T Customers to dial "9" when placing calls outside the CENTREX System. When dedicated facilities are utilized, BellSouth will provide, upon AT&T's request, station ID or ANI, as well as FGD trunking.
- 25.1.7 AT&T may use remote call forwarding in conjunction with CENTREX Service to provide service to AT&T Local Service Customers residing outside of the geographic territory in which BellSouth provides local exchange service. In cases where existing BellSouth Customers choose AT&T for their local service provider, and where AT&T serves these Customers via CENTREX, in order that such Customers may keep the same phone number, BellSouth shall either move Customer's line and phone number to a CENTREX system, or use remote call forwarding to route Customer's old phone number to new CENTREX phone number. Not all features and functions will be compatible when remote call forwarding is utilized. In such cases, AT&T customers shall have the same functionality as BellSouth customers under the same circumstances.

  
FLS/10/97

25.1.8 **DELETED**

25.1.9 BellSouth shall make available to AT&T for resale, at no additional charge, intercom calling among all AT&T Customers who utilize resold CENTREX service where the AT&T Customers' numbers all reside in the same central office switch.

25.1.10 AT&T may utilize BellSouth's Automatic Route Selection (ARS) service features to provision and route calls from various end users to various Interexchange Carriers (IXC) Networks.

25.2 **CLASS and Custom Features Requirements**

AT&T may purchase the entire set of CLASS and Custom features and functions, or a subset of any one or any combination of such features, on a Customer-specific basis, without restriction on the minimum or maximum number of lines or features that may be purchased for any one level of service. BellSouth shall provide to AT&T a list of all such CLASS and Custom features and functions within ten (10) days of the Effective Date and shall provide updates to such list when new features and functions become available.

25.3 **Voluntary Federal and State Customer Financial Assistance Programs**

Local Services provided to low-income subscribers, pursuant to requirements established by the appropriate state regulatory body, include programs such as Voluntary Federal Customer Financial Assistance Program and Link-Up America ("Voluntary Federal Customer Financial Assistance Programs"). When a BellSouth Customer eligible for the Voluntary Federal Customer Financial Assistance Program or other similar state programs chooses to obtain Local Service from AT&T, BellSouth shall forward available information regarding such Customer's eligibility to participate in such programs to AT&T, in accordance with procedures to be mutually established by the Parties and applicable state and federal law.

25.4 **E911/911 Services**

BellSouth shall provide access to E911/911 in the same manner that it is provided to BellSouth Customers. BellSouth will enable AT&T Customers to have E911/911 call routing to the appropriate Public Safety Answering Point (PSAP). BellSouth shall provide and validate AT&T Customer information to the PSAP. BellSouth shall use its service order process to update and maintain, on the same schedule that it uses for its end users, the AT&T Customer service information in the ALI/DMS (Automatic Location Identification/Database Management System) used to support E911/911 services.

25.4.1 **DELETED**

25.4.2 **Telephone Relay Service**

Where BellSouth provides to speech and hearing-impaired callers a service that enables callers to type a message into a telephone set equipped with a keypad and message screen and to have a live operator read the message to a recipient and to type message recipient's response to the speech or hearing-impaired caller ("Telephone Relay Service"), BellSouth shall make such service available to AT&T at no additional charge, for use by AT&T Customers who are speech or hearing-impaired. If BellSouth maintains a record of Customers who qualify under any applicable law for Telephone Relay Service, BellSouth shall make such data available to AT&T as it pertains to AT&T Customers.

25.5 **Contract Service Arrangements ("CSAs")**

25.5.1 CSAs shall be available for resale at the wholesale discount.

25.5.2 If AT&T identifies a specific CSA, BellSouth shall provide AT&T a copy within ten (10) business days of AT&T's request.

25.6 **DELETED**

25.7 **DELETED**

25.8 **DELETED**

25.9 **DELETED**

25.10 **Nonrecurring Services**

25.10.1 BellSouth shall offer for resale all non-recurring services.

25.11 **Inside Wire Maintenance Service**

25.11.1 BellSouth shall provide Inside Wire Maintenance Service for resold services, but the resale discount will not apply.

25.12 **Pay Phone Service**

BellSouth shall offer for resale, at a minimum, the following pay phone services: Coin Line (currently sold as SmartLine<sup>SM</sup>), COCOT Line Coin (currently sold as Independent Payphone Provider (IPP) Line), and COCOT Line Coinless (currently sold as IPP Line Coinless). To the extent BellSouth demonstrates that it does not provide the payphone features and functionality requested by AT&T to BellSouth Customers, AT&T may request that BellSouth provide such functionality pursuant to the Bona Fide Request Process identified in Section 1.1 of the General Terms and Conditions of this Agreement.

Billed Number Screening  
 Originating line screening  
 Ability to 'freeze' PIC selection  
 One bill per line  
 Point of demarcation at the Network Interface location  
 Detailed billing showing all 1+ traffic on paper, diskette or  
 electronic format  
 Wire Maintenance option  
 Touchtone service  
 Option for listed or non-listed numbers  
 Access to 911 service  
 One directory per line  
 Access to ANI Information  
 Line and/or station monitoring and diagnostic routines

25.12.1 In addition, BellSouth shall offer for resale, at a minimum, the following features with its resold Coin Line service:

Access to all CO intelligence required to perform answer detection, coin  
 collection, coin return, and disconnect.  
 Answer Detection  
 Option to block all 1+ calls to international destinations  
 IntraLATA Call Timing  
 Option of one way or two way service on line  
 Coin Refund and Repair Referral Service  
 Ability to block any 1+ service that cannot be rated by the coin circuits  
 AT&T rate tables for local and intraLATA service  
 Option of Flat Rate Service or Measured Service or both  
 Protect against clip on fraud  
 Protect against blue box fraud

25.12.2 BellSouth shall offer for resale, at a minimum, the following features with its COCOT Line Coin and COCOT Line Coinless services:

Ability to keep existing serving telephone numbers if cutover to AT&T  
 Resale Line  
 Option of One Way or Two Way service on the line  
 Option of Flat Rate Service or Measured Service or both

25.12.3 BellSouth shall offer for resale, at a minimum, the following feature with its COCOT Line Coin service:

Blocking for 1+ international, 10XXXX1+ international, 101XXXX1+  
 international, 1+900, N11, 976  
 Option to block all 1-700 and 1-500 calls  
 Line side supervision option

  
 FL6/10/97

25.12.4 BellSouth shall offer for resale, at a minimum, the following features with its COCOT Line Coinless service:

Blocking for 1+ international, 10XXXX1+ international, 101XXXX1+ international, 1+900, N11, 976, 7 or 10 digit local, 1-DDD

25.12.5 BellSouth shall offer for resale, at a minimum, the following features with its SemiPublic Coin service:

Ability to keep existing serving telephone numbers if cutover to AT&T

Touchtone Service

Option for listed, nonlisted, or non published numbers

Provision 911 service

Access to ANI information

Access to all CO intelligence required to perform answer supervision, coin collect, coin return and disconnect

Far end disconnect recognition

Call timing

PIC protection for all 1+local, interLATA, and intraLATA traffic

Same call restrictions as available on BellSouth phones for interLATA, international, intraLATA, and local calling

One bill per line

Detailed billing showing all 1+ traffic in paper or electronic format

Option to have enclosure installed with set

One directory per line installed

Install the station to at least BellSouth standards

Ability to block any 1+ service that cannot be rated by the coin circuits

AT&T to be the PIC for local and intraLATA calls

Option to block all 1+ international calls

Option of one way or two way service

Wire Maintenance option

AT&T rate tables for local and intraLATA service

Option to have BellSouth techs collect, count, and deposit vault contents on behalf of AT&T

Monitor vault contents for slugs and spurious non-US currency or theft and notify AT&T of discrepancies

Station or enclosure equipment should only bear the name/brand designated by AT&T on the order form

Protect against clip on fraud

Protect against red box fraud

Protect against blue box fraud

Provide option for use of "bright" station technology including debit cards

Provide revenue, maintenance, collection reports as specified by



- AT&T on order form on a periodic basis in paper or electronic format
- 25.12.6 BellSouth shall provide the following features for Coin Line, SemiPublic Coin, COCOT Line Coin, and COCOT Line Coinless services:
- Blocking of inbound international calls
  - Point of demarcation at the set location
  - Special screen codes unique to AT&T and/or its Customers
  - Single Point of Contact for bills and orders dedicated to Public
  - Service outage transfers to AT&T help center
  - Access to AT&T Directory Assistance
  - Access to AT&T's Network Access Interrupt
  - Use AT&T branded invoice
  - Provide all information requested to ensure AT&T can bill for access line
  - Provide all information requested to ensure AT&T can bill for usage on the line
  - All calls originating from stations serviced by these lines should be routed to AT&T lines, except where designated
- 25.13 **Voice Mail Service**
- 25.13.1 Where available to BellSouth's end users, BellSouth shall provide the following feature capabilities to allow for voice mail services:
- Station Message Desk Interface - Enhanced ("SMDI-E")
  - Station Message Desk Interface ("SMDI")
  - Message Waiting Indicator ("MWI") stutter dialtone and message waiting light feature capabilities
  - Call Forward on Busy/Don't Answer ("CF-B/DA")
  - Call Forward on Busy ("CF/B")
  - Call Forward Don't Answer ("CF/DA")
- 25.14 **Hospitality Service**
- 25.14.1 BellSouth shall provide all blocking, screening, and all other applicable functions available for hospitality lines.
- 25.15 **Blocking Service**
- 25.15.1 BellSouth shall provide blocking of 700, 900, and 976 services individually or in any combination upon request, including bill to third Party and collect calls, from AT&T on a line, trunk, or individual service basis at party with what BellSouth provides its end users.
26. **DELETED**
- 26.1 **DELETED**

26.1.1 DELETED

26.1.2 DELETED

26.1.3 DELETED

26.1.4 DELETED

27 Support Functions

27.1 **Routing to Directory Assistance, Operator and Repair Services**

27.1.1 BellSouth shall make available to AT&T the ability to route:

27.1.1.1 Local Directory Assistance calls (411, (NPA) 555 1212) dialed by AT&T Customers directly to the AT&T Directory Assistance Services platform. Local Operator Services calls (0+, 0-) dialed by AT&T Customers directly to the AT&T Local Operator Services Platform. Such traffic shall be routed over trunk groups between BellSouth end offices and the AT&T Local Operator Services Platform, using standard Operator Services dialing protocols of 0+ or 0-.

27.1.1.2 611 repair calls dialed by AT&T Customers directly to the AT&T repair center.

27.1.2 Until a permanent industry solution exists for routing of traffic from BellSouth's local switch to other than BellSouth platforms, BellSouth will provide such routing using line class codes. BellSouth agrees to work with AT&T on a routing resource conservation program to relieve routing resource constraints to ensure that no switch exceeds 95% capacity of line class codes. BellSouth and AT&T shall continue to work with the appropriate industry groups to develop a long-term solution for selective routing. BellSouth may reserve for itself an appropriate and reasonable number of line class codes for its own use.

27.1.3 All direct routing capabilities described herein shall permit AT&T Customers to dial the same telephone numbers for AT&T Directory Assistance, Local Operator Service and Repair that similarly situated BellSouth Customers dial for reaching equivalent BellSouth services.

27.1.4 BellSouth, no later than fifteen (15) days after the Effective Date, shall provide to AT&T, the emergency public agency (e.g., police, fire, ambulance) telephone numbers linked to each NPA-NXX. Such data will be compiled as an electronic flat file in a mutually agreed format and transmitted via either diskette or Network Data Mover. BellSouth will transmit to AT&T, in a timely manner, all changes, alterations, modifications and updates to such data base via the same method as the initial transfer.

27.2 **Operator Services - Interim Measures**

27 2 1 Where BellSouth is the provider of Directory Assistance service, BellSouth agrees to provide AT&T Customers with the same Directory Assistance available to BellSouth Customers. If requested by AT&T, BellSouth will provide AT&T Directory Assistance Service under the AT&T brand.

27 2 1.1 AT&T recognizes that BellSouth's providing to AT&T Directory Assistance Service under AT&T's brand may require additional costs to be incurred by BellSouth. BellSouth will charge AT&T for such branded Directory Assistance capability under the wholesale rate plus the reasonable and demonstrable costs necessary to implement AT&T's branding request.

27 2.2 Additionally, BellSouth warrants that such service will provide the following minimum capabilities to AT&T's Customers:

- (1) Two Customer listings and/or addresses per AT&T Customer call.
- (2) Name and address to AT&T Customers upon request, except for unlisted numbers, in the same states where such information is provided to BellSouth Customers.
- (3) Upon request, call completion to the requested number for local and intraLATA toll calls, where this service is available.
- (4) Populate the listing database in the same manner and in the same time frame as if the Customer was a BellSouth Customer.
- (5) Any information provided by a Directory Assistance Automatic Response Unit (ARU) will be repeated the same number of times for AT&T Customers as for BellSouth's Customers.
- (6) Service levels will comply with Tennessee Regulatory Authority requirements for:
  - a) number of rings to answer
  - b) average work time
  - c) disaster recovery options.
- (7) Intercept service for Customers moving service will include:
  - a) referral to new number, either 7 or 10 digits
  - b) repeat of the new number twice on the referral announcement
  - c) repeat of the new recording twice.

27.2.3 BellSouth shall provide Operator Services to AT&T's Customers at the same level of service available to BellSouth end users.

27.2.4 **DELETED**

27.2.5 BellSouth agrees to provide AT&T Customers the same Operator Services available to BellSouth Customers, branded as required by Section 19.

27.2.6 Additionally, BellSouth warrants that such service will provide the following minimum capabilities to AT&T Customers:

- (1) Instant credit on calls, as provided to BellSouth Customers
- (2) Routing of calls to AT&T when requested via existing Operator Transfer Service (OTS).
- (3) Busy Line Verification/Emergency Line Interrupt (BLV/ELI) services.
- (4) Emergency call handling.
- (5) Notification of the length of call.
- (6) Caller assistance for the disabled in the same manner as provided to BellSouth Customers.
- (7) Handling of collect calls: person to person and/or station to station.

### 27.3 **Busy Line Verification and Emergency Line Interrupt**

Where BellSouth does not route Operator Services traffic to AT&T's platform, BellSouth shall perform Busy Line Verification and Emergency Line Interrupt for AT&T on resold BellSouth lines. Where BellSouth routes Operator Services traffic to AT&T's platform, BellSouth shall provide BLV/ELI services when requested by AT&T Operators. AT&T and BellSouth shall work together to ensure that sufficient facilities exist to support increased BLV/ELI volume due to AT&T's presence as a Local Service provider. Specifically, BellSouth will engineer its BLV/ELI facilities to accommodate the anticipated volume of BLV/ELI requests during the Busy Hour. AT&T may, from time to time, provide its anticipated volume of BLV/ELI requests to BellSouth for planning purposes. In those instances when the BLV/ELI facilities/systems cannot satisfy forecasted volumes, BellSouth shall promptly inform AT&T, and the Parties shall work together to resolve capacity problems expeditiously.

### 27.4 **Access to the Line Information Database**

*UB*  
FL6/10/97

BellSouth shall use its service order process to update and maintain, on the same schedule that it uses for its end users, the AT&T Customer service information in the Line Information Database ("LIDB")

27.5 **Telephone Line Number Calling Cards**

Effective as of the date of an end-user's subscription to AT&T Service, BellSouth will terminate its existing telephone line number - based calling cards and remove any BellSouth-assigned Telephone Line Calling Card Number (including area code) ("TLN") from the LIDB. AT&T may issue a new telephone calling card to such Customer, utilizing the same TLN and enter such TLN in LIDB for calling card validation purposes via the service order process.

28. **Service Functions**

28.1 **Electronic Interface**

BellSouth shall provide real time electronic interfaces ("EI") for transferring and receiving Service Orders and Provisioning data and materials (e.g., access to Street Address Guide ("SAG") and Telephone Number Assignment database). These interfaces shall be administered through a gateway that will serve as a point of contact for the transmission of such data from AT&T to BellSouth, and from BellSouth to AT&T. The requirements and implementation of such a data transfer system shall be negotiated in good faith by the Parties as specified below and in Attachment 15 of this Agreement. AT&T and BellSouth agree to use best efforts to provide the Electronic Communications gateway described above as soon as practicable, but in no event later than the dates specified in Attachment 15. In addition, (i) BellSouth agrees to use its best efforts to carry out its responsibilities, and (ii) AT&T agrees to use its best efforts to carry out its responsibilities. AT&T and BellSouth have agreed on interim solutions described below and in Attachment 15 to address the Pre-ordering, Ordering and Provisioning interfaces. BellSouth warrants that such interim solutions shall provide AT&T Customers with the same level of service available to BellSouth Customers.

28.1.1 **Pre-Ordering**

28.1.1.1 **DELETED**

28.1.1.2 **DELETED**

28.1.1.3 BellSouth will supply AT&T with Interval Guide Job Aids to be used to determine service installation dates. BellSouth will implement an electronic interface to its Due Date Support Application (DSAP) by December 31, 1996 but no later than April 1, 1997.

*MB*  
FL6/10/97

- 28.1.1.4 BellSouth will reserve up to 100 telephone numbers per NPA-NXX at AT&T's request, for AT&T's sole use. BellSouth will provide additional numbers at AT&T's request in order that AT&T have sufficient numbers available to meet expected needs. The telephone number reservations made in this manner are valid for AT&T's assignment for ninety (90) days from the reservation date. BellSouth will make the telephone number reservations available to AT&T via diskette by no later than August 15, 1996 and by electronic file transfer no later October 15, 1996. BellSouth agrees to implement an electronic interface to improve this process by December 31, 1996, but no later than April 1, 1997.
- 28.1.1.5 BellSouth Local Carrier Service Center (LCSC) will assign vanity numbers and blocks of numbers for use with complex services including, but not limited to, DID and Hunting arrangements, as requested by AT&T, and documented in Work Center Interface agreements.
- 28.1.1.6 BellSouth will migrate all Pre-ordering functionality to the "Pre-Ordering" Electronic Communications Gateway by December 31, 1996, but no later than April 1, 1997. This migration effort shall be accomplished as described by BellSouth in its "Phase II interactive solution" report to the Georgia Public Service Commission of July 21, 1996.
- 28.1.2 **Ordering**
- 28.1.2.1 BellSouth agrees to develop, and AT&T agrees to cooperate in the development of, a mutually acceptable Electronic Data Interchange (EDI) for ordering Local Services. The ordering process and related transactions, (i.e., order, confirmation, firm order commitments, supplements and completions) shall be via the EDI interface.
- 28.1.2.2 BellSouth agrees to implement the EDI interface to support processes for Local Services for residence POTS and features, business POTS and features and PBX trunks with Direct Inward Dialing by September 1, 1996. By December 15, 1996, all Local Services shall be available for ordering via EDI interface.
- 28.1.2.3 **DELETED**
- 28.2 **Work Order Processes**
- 28.2.1 BellSouth shall ensure that all work order processes used to provision Local Service to AT&T for resale meet the service parity requirements set forth in this part.
- 28.2.2 Prior to AT&T sending BellSouth the first Service Order, BellSouth and AT&T shall develop mutually agreed-upon escalation and expedite procedures to be employed at any point in the Service Ordering, Provisioning, Maintenance.

*MB*  
FL6/10/97

Billing and Customer Usage Data transfer processes to facilitate rapid and timely resolution of disputes. These procedures will be maintained in the Work Center Interface Agreements.

**28.3 Point of Contact for the AT&T Customer**

**28.3.1** Except as otherwise provided in this Agreement, AT&T shall be the single and sole point of contact for all AT&T Customers.

**28.3.2 DELETED**

**28.3.3** BellSouth shall ensure that all BellSouth representatives who receive inquiries regarding AT&T services when providing services on behalf of AT&T: (i) refer such inquiries to AT&T at a telephone number provided by AT&T; (ii) do not in any way disparage or discriminate against AT&T, or its products or services; and (iii) do not provide information about BellSouth products or services.

**28.4 Single Point of Contact**

**28.4.1** Each Party shall provide the other Party with a single point of contact ("SPOC") for all inquiries regarding the implementation of this Part. Each Party shall accept all inquiries from the other Party and provide timely responses.

**28.4.2** BellSouth Contact numbers will be kept current in the Work Center Interface Agreements.

**28.5 Service Order**

To facilitate the ordering of new service for resale or changes to such service to an AT&T Customer ("Service Order"), BellSouth shall provide AT&T's representative with real time access (as described in Section 28.1 of this Part 1) to BellSouth Customer information to enable the AT&T representative to perform the following tasks:

**28.5.1** Obtain Customer profile information via telephone. Methods and procedures for this interim interface will be defined in a Work Center Interface Agreement.

**28.5.2** Obtain information on all Telecommunication Services that are available for resale, including new services via an electronic file with feature and service information in each BellSouth switch.

**28.5.3** BellSouth will provide AT&T with interactive direct order entry no later than March 31, 1997. Until this capability is available, BellSouth agrees to establish the Local Carrier Service Center (LCSC) as the SPOC for order entry. Orders will be received at the LCSC via the EDI interface. BellSouth agrees to enter

*ELB*  
FLS/10/97

the Service Order promptly on receipt and provide Firm Order Confirmation (FOC) within 24 hours of receipt of a correct Local Service Request

- 28.5.4 BellSouth will provide AT&T with on line access to telephone number reservations by December 31, 1996, but no later April 1, 1997. Until on line access is available via electronic interface, BellSouth agrees to provide AT&T with a ready supply of telephone numbers. The process for telephone number reservations is described in Section 28.1.1.4 of this Agreement.
- 28.5.5 BellSouth will provide AT&T with the capability to establish directory listings via the Service Order Process.
- 28.5.6 BellSouth will provide AT&T with the appropriate information and training materials (job aids) to assist AT&T work centers to determine whether a service call will be required on a service installation. These job aids are to be the same information available to BellSouth employees.
- 28.5.7 BellSouth will provide AT&T on line ability to schedule dispatch and by December 31, 1996 but no later than April 1, 1997. Until on line access is available, BellSouth agrees to provide AT&T with interval guides for BellSouth services.
- 28.5.8 BellSouth will provide AT&T with the ability to order local service, local intraLATA toll service, and designate the end users' choice of primary intraLATA and interLATA Interexchange Carriers on a single unified order.
- 28.5.9 BellSouth will suspend, terminate or restore service to an AT&T Customer at AT&T's request.
- 28.6 **Provisioning**
- 28.6.1 **DELETED**
- 28.6.1.1 **DELETED**
- 28.6.1.2 **DELETED**
- 28.6.1.3 **DELETED**
- 28.6.1.4 **DELETED**
- 28.6.1.5 **DELETED**
- 28.6.2 BellSouth shall provide AT&T with service status notices, within mutually agreed-upon intervals. Such status notices shall include the following:

*UB*  
FL6/10/97



- 28.6.2 Firm order confirmation, including service availability date and information regarding the need for a service dispatch for installation.
- 28.6.3 BellSouth will provide AT&T with on-line notice of service installation by no later than March 31, 1997. Until this capability is available, BellSouth will provide AT&T with completion information on a daily basis for all types of Service Orders. BellSouth will utilize the EDI interface to transmit that data to AT&T if an installation requires deviation from the Service Order in any manner, or if an AT&T Customer requests a service change at the time of installation. BellSouth will call AT&T in advance of performing the installation for authorization. BellSouth will provide to AT&T at that time an estimate of additional labor hours and/or materials required for that installation. After installation is completed, BellSouth will immediately inform AT&T of actual labor hours and/or materials used.
- 28.6.4 BellSouth will provide AT&T with on-line information exchange for Service Order rejections, Service Order errors, installation jeopardies and missed appointments by no later than March 31, 1997, until this capability is available. BellSouth agrees to:
- 28.6.4.1 Use its best efforts to notify AT&T via telephone of any Service Order rejections or errors within one hour of receipt;
- 28.6.4.2 Confirm such telephone notices in writing via facsimile at the end of each business day; and
- 28.6.4.3 BellSouth shall promptly notify AT&T via telephone if an installation or service appointment is in jeopardy of being missed.
- 28.6.4.4 The notification process will be described further in the Work Center Interface agreement between AT&T and BellSouth.
- 28.6.5 **DELETED**
- 28.6.6 BellSouth will provide AT&T with on-line information on charges associated with necessary construction no later than March 31, 1997. Until this capability is available, BellSouth agrees that BellSouth's LCSC will promptly notify AT&T of any charges associated with necessary construction.
- 28.6.7 BellSouth will provide AT&T with on-line access to status information on Service Orders no later than March 31, 1997. Until this capability is available, BellSouth agrees to provide status at the following critical intervals: acknowledgment, firm order confirmation, and completion on Service Orders. In addition, BellSouth Local Carrier Service Center will provide AT&T with status, via telephone, upon request.



FL6/10/97

- 28.6.8 BellSouth will perform all pre-service testing on resold Local Services.
- 28.6.9 Where BellSouth provides installation and the AT&T Customer requests a service change at the time of installation, BellSouth shall immediately notify AT&T at the telephone number on the Service Order of that request. The BellSouth technician should notify AT&T in the presence of the AT&T Customer so that AT&T can negotiate authorization to install the requested services directly with that Customer and the technician, and revise appropriate ordering documents as necessary.
- 28.6.10 To ensure that AT&T's Customers have the same ordering experience as BellSouth's Customers:
- 28.6.10.1 BellSouth shall provide AT&T with the capability to have AT&T's Customer orders input to and accepted by BellSouth's Service Order Systems outside of normal business hours, twenty-four (24) hours a day, seven (7) days a week, the same as BellSouth's Customer orders received outside of normal business orders are input and accepted.
- 28.6.10.2 Such ordering and provisioning capability shall be provided via an electronic interface, except for scheduled electronic interface downtime. Downtime shall not be scheduled during normal business hours and shall occur during times where systems experience minimum usage.
- 28.6.10.3 Until the Electronic Interface is available, BellSouth shall provide Local Carrier Service Center (LCSC) order entry capability to AT&T to meet the requirements set forth in Section 28.6.10.1 above.
- 28.6.11 BellSouth shall provide training for all BellSouth employees who may communicate with AT&T Customers, during the provisioning process. Such training shall conform to Section 19 of the General Terms and Conditions of this Agreement.
- 28.6.12 BellSouth will provide AT&T with the capability to provide AT&T Customers the same ordering, provisioning intervals, and level of service experiences as BellSouth provides to its own Customers, in accordance with standards or other measurements that are at least equal to the level that BellSouth provides or is required to provide by law and its own internal procedures.
- 28.6.13 BellSouth will maintain and staff an account team to support AT&T's inquiries concerning the ordering of local complex service and designed business services for local services resale. This team will provide information regarding all services, features and functions available, know the forms and additional information required beyond the standard local service request, assist AT&T in preparation of such orders, and coordinate within BellSouth.

  
FL6/10/97

- 28.6.14 BellSouth will provide AT&T with the information AT&T will need to identify Customers as exempt from charges, or eligible for reduced charges associated with the provisioning of new services, including but not limited to handicapped individuals, and certain governmental bodies and public institutions. BellSouth when notified that an order for new service is exempt in some fashion, will not bill AT&T.
- 28.6.15 BellSouth will provide the same intercept treatment and transfer of service announcements to AT&T's Customers as BellSouth provides to its own end users without any branding.
- 28.6.16 BellSouth will provide AT&T with appropriate notification of all area transfers with line level detail 120 days before service transfer, and will also notify AT&T within 120 days before such change of any LATA boundary changes, or within the time frame required by an approving regulatory body, if any.
- 28.6.17 BellSouth agrees to develop with AT&T's cooperation, mutually acceptable interface agreements between work centers regarding the exchange of information and process expectations.
- 28.6.18 BellSouth will suspend AT&T local Customers' service upon AT&T's request via the receipt of a Local Service Request. The service will remain suspended until such time as AT&T submits a Local Service Request requesting BellSouth to reactivate.
- 28.6.19 BellSouth will provide AT&T's end users the same call blocking options available to BellSouth's own end users.
- 28.6.20 BellSouth will work cooperatively with AT&T in practices and procedures regarding Law Enforcement and service annoyance call handling. To the extent that circuit-specific engineering is required for resold services, BellSouth will provide the same level of engineering support as BellSouth provides for its comparable retail services.
- 28.6.21 BellSouth will provide information about the certification process for the provisioning of LifeLine, Link-up and other similar services.
- 28.6.22 BellSouth will provide a daily electronic listing of AT&T Customers who change their local carrier. The process is described as OUTPLOC (See reference in Local Account Maintenance Requirements of Attachment 7.)
- 28.7 **Maintenance**
- Maintenance shall be provided in accordance with the requirements and standards set forth in Attachment 5. Maintenance will be provided by

BellSouth in accordance with the service parity requirements set forth in this Part.

**28.8 Provision of Customer Usage Data**

BellSouth shall provide the Customer Usage Data recorded by the BellSouth. Such data shall include complete AT&T Customer usage data for Local Service, including both local and intraLATA toll service (e.g., call detail for all services, including flat-rated and usage-sensitive features), in accordance with the terms and conditions set forth in Attachment 7.

**28.9 Service/Operation Readiness Testing**

**28.9.1** In addition to testing described elsewhere in this Section, BellSouth shall test the systems used to perform the following functions in a mutually agreed upon time frame prior to commencement of BellSouth's provision of Local Service, in order to establish system readiness capabilities:

**28.9.1.1** All interfaces between AT&T and BellSouth work centers for Service Order, Provisioning;

**28.9.1.2** Maintenance, Billing and Customer Usage Data;

**28.9.1.3** The process for BellSouth to provide Customer profiles;

**28.9.1.4** The installation scheduling process;

**28.9.1.5** **DELETED**

**28.9.1.6** Telephone number assignment;

**28.9.1.7** Procedures for communications and coordination between AT&T SPOC and BellSouth SPOC;

**28.9.1.8** Procedures for transmission of Customer Usage Data; and

**28.9.1.9** Procedures for transmitting bills to AT&T for Local Service; and the process for wholesale billing for local service.

**28.9.2** The functionalities identified above shall be tested by BellSouth in order to determine whether BellSouth performance meets the applicable service parity requirements, quality measures and other performance standards set forth in this Agreement. BellSouth shall make available sufficient technical staff to perform such testing. BellSouth technical staff shall be available to meet with AT&T as necessary to facilitate testing. BellSouth and AT&T shall mutually agree on the schedule for such testing.

28.9.3 At AT&T's reasonable request, BellSouth shall provide AT&T with service readiness test results of the testing performed pursuant to the terms of this Part.

28.9.4 During the term of this Agreement, BellSouth shall participate in cooperative testing requested by AT&T whenever both companies agree it is necessary to ensure service performance, reliability and Customer serviceability.

**28.10 Billing For Local Service**

28.10.1 BellSouth shall bill AT&T for Local Service provided by BellSouth to AT&T pursuant to the terms of this Part, and in accordance with the terms and conditions for Connectivity Billing and Recording in Attachment 6.

28.10.2 BellSouth shall recognize AT&T as the Customer of record for all Local Service and will send all notices, bills and other pertinent information directly to AT&T unless AT&T specifically requests otherwise.

PART II: UNBUNDLED NETWORK ELEMENTS

29

Introduction

This Part II sets forth the unbundled Network Elements that BellSouth agrees to offer to AT&T in accordance with its obligations under Section 251(c)(3) of the Act. The specific terms and conditions that apply to the unbundled Network Elements and the requirements for each Network Element are described below and in the Network Elements Service Description, Attachment 2. The price for each Network Element is set forth in Part IV of this Agreement. BellSouth shall offer Network Elements to AT&T as of the Effective Date.

30.

Unbundled Network Elements

30.1

BellSouth shall offer Network Elements to AT&T on an unbundled basis on rates, terms and conditions that are just, reasonable, and non-discriminatory in accordance with the terms and conditions of this Agreement.

30.2

BellSouth will permit AT&T to interconnect AT&T's facilities or facilities provided by AT&T or by third Parties with each of BellSouth's unbundled Network Elements at any point designated by AT&T that is technically feasible.

30.3

BellSouth will deliver to AT&T's Served Premises any interface that is technically feasible. AT&T, at its option, may designate other interfaces through the Bona Fide Request process delineated in Attachment 14.

30.4

AT&T may use one or more Network Elements to provide any feature, function, or service option that such Network Element is capable of providing or any feature, function, or service option that is described in the technical references identified herein.

30.5

BellSouth shall offer each Network Element individually and in combination with any other Network Element or Network Elements in order to permit AT&T to provide Telecommunications Services to its Customers subject to the provisions of Section 1A of the General Terms and Conditions of this Agreement.

30.6

For each Network Element, BellSouth shall provide a demarcation point (e.g., an interconnection point at a Digital Signal Cross Connect or Light Guide Cross Connect panel or a Main Distribution Frame) and, if necessary, access to such demarcation point, which AT&T agrees is suitable. However, where BellSouth provides contiguous Network Elements to AT&T, BellSouth may provide the existing interconnections

*MB*  
FL5/10/97

and no demarcation point shall exist between such contiguous Network Elements.

30.7 **DELETED**

30.8 The charge assessed to AT&T to interconnect any Network Element or Combination to any other Network Element or Combination provided by BellSouth to AT&T if BellSouth does not directly interconnect the same two Network Elements or Combinations in providing any service to its own Customers or a BellSouth affiliate (e.g., the interconnection required to connect the Loop Feeder to an ALEC's collocated equipment), shall be cost based.

30.9 Attachment 2 of this Agreement describes the Network Elements that AT&T and BellSouth have identified as of the Effective Date of this Agreement. AT&T and BellSouth agree that the Network Elements identified in Attachment 2 are not exclusive. Either Party may identify additional or revised Network Elements as necessary to improve services to Customers, to improve network or service efficiencies or to accommodate changing technologies, Customer demand, or regulatory requirements. Upon BellSouth's identification of a new or revised Network Element, BellSouth shall notify AT&T of the existence of and the technical characteristics of the new or revised Network Element.

AT&T shall make it's request for a new or revised Network Element pursuant to the Bona Fide Request Process identified in Section 1.1 of the General Terms and Conditions of this Agreement. Additionally, if BellSouth provides any Network Element that is not identified in this Agreement, to itself, to its own Customers, to a BellSouth affiliate or to any other entity, BellSouth will provide the same Network Element to AT&T on rates, terms and conditions no less favorable to AT&T than those provided to itself or to any other Party. Additional descriptions and requirements for each Network Element are set forth in Attachment 2.

30.9.1 **DELETED**

30.9.2 **DELETED**

30.9.3 **DELETED**

30.9.4 **DELETED**

30.9.5 **DELETED**

30.9.6 **DELETED**

30.9.7 **DELETED**

- 30.9.8 DELETED
- 30.9.9 DELETED
- 30.9.10 DELETED
- 30.9.11 DELETED
- 30.10 **Standards for Network Elements**
- 30.10.1 BellSouth shall comply with the requirements set forth in the technical references, as well as any performance or other requirements identified in this Agreement, to the extent that they are consistent with the greater of BellSouth's actual performance or applicable industry standards. If another Bell Communications Research, Inc. ("Bellcore"), or industry standard (e.g., American National Standards Institute ("ANSI")) technical reference or a more recent version of such reference sets forth a different requirement, AT&T may request, where technically feasible, that a different standard apply by making a request for such change pursuant to the Bona Fide Request Process identified in Section 1.1 of the General Terms and Conditions of this Agreement.
- 30.10.2 If one or more of the requirements set forth in this Agreement are in conflict, the parties shall mutually agree on which requirement shall apply. If the parties cannot reach agreement, the Alternative Dispute Resolution Process identified in Section 16 of the General Terms and Conditions of this Agreement shall apply.
- 30.10.3 Each Network Element provided by BellSouth to AT&T shall be at least equal in the quality of design, performance, features, functions and other characteristics, including but not limited to levels and types of redundant equipment and facilities for power, diversity and security, that BellSouth provides in the BellSouth network to itself, BellSouth's own Customers, to a BellSouth affiliate or to any other entity for the same Network Element.
- 30.10.3.1 DELETED
- 30.10.3.2 BellSouth agrees to work cooperatively with AT&T to provide Network Elements that will meet AT&T's needs in providing services to its Customers.
- 30.10.4 Unless otherwise designated by AT&T, each Network Element and the interconnections between Network Elements provided by BellSouth to AT&T shall be made available to AT&T on a priority basis that is equal to or better than the priorities that BellSouth provides to itself, BellSouth's own Customers, to a BellSouth affiliate or to any other entity for the same Network Element.



FL6/10/97



### PART III: ANCILLARY FUNCTIONS

#### 31. Introduction

This Part and Attachment 3 set forth the Ancillary Functions and requirements for each Ancillary Function that BellSouth agrees to offer to AT&T so that AT&T may provide Telecommunication Services to its Customers.

#### 32. BellSouth Provision of Ancillary Functions

Part IV of this Agreement sets forth the prices for such Ancillary Functions. BellSouth will offer Ancillary Functions to AT&T on rates, terms and conditions that are just, reasonable, and non-discriminatory and in accordance with the terms and conditions of this Agreement.

32.1 The Ancillary Functions that AT&T has identified as of the Effective Date of this Agreement are Collocation, Rights Of Way (ROW), Conduits and Pole Attachments. AT&T and BellSouth agree that the Ancillary Functions identified in this Part III are not exclusive. Either Party may identify additional or revised Ancillary Functions as necessary to improve services to Customers, to improve network or service efficiencies or to accommodate changing technologies, Customer demand, or regulatory requirements. Upon BellSouth's identification of a new or revised Ancillary Function, BellSouth shall notify AT&T of the existence of and the technical characteristics of the new or revised Ancillary Function.

AT&T shall make its request for a new or revised Ancillary Function pursuant to the Bona Fide Request Process identified in Section 1.1 of the General Terms and Conditions of this Agreement.

32.2 If BellSouth provides any Ancillary Function to itself, to its own Customers, to a BellSouth affiliate or to any other entity, BellSouth will provide the same Ancillary Function to AT&T at rates, terms and conditions no less favorable to AT&T than those provided by BellSouth to itself or to any other Party. The Ancillary Functions and requirements for each Ancillary Function are set forth in Attachment 3.

#### 33. Standards for Ancillary Functions

33.1 Each Ancillary Function shall meet or exceed the requirements set forth in the technical references, as well as the performance and other requirements, identified in this Agreement. If another Bell Communications Research, Inc. ("Bellcore"), or industry standard (e.g., American National Standards Institute ("ANSI")) technical reference sets forth a different requirement, AT&T may elect, where technically feasible, which standard shall apply by making a request for such change pursuant

to the Bona Fide Request Process identified in Section 1.1 of the General Terms and Conditions of this Agreement.

33.2 Except as otherwise expressly agreed to herein, each Ancillary Function provided by BellSouth to AT&T herein shall be at least equal in the quality of design, performance, features, functions and other characteristics, including, but not limited to levels and types of redundant equipment and facilities for diversity and security, that BellSouth provides in BellSouth network to itself, its own Customers, its affiliates or any other entity. This Section is not intended to limit BellSouth's ability during this Agreement to offer to AT&T nor AT&T's ability to accept Ancillary Functions with varying degrees of features, functionalities and characteristics.

33.3 **DELETED**

33.3.1 BellSouth agrees to work cooperatively with AT&T to provide Ancillary Functions that will meet AT&T's needs in providing services to its Customers.

33.4 Ancillary Functions provided by BellSouth to AT&T shall be allocated to AT&T on a basis that is at least equal to that which BellSouth provides to itself, its Customers, its affiliates or any other entity.

PART IV: PRICING34. General Principles

All services currently provided hereunder (including resold Local Services Network Elements, Combinations and Ancillary Functions) and all new and additional services to be provided hereunder shall be priced in accordance with all applicable provisions of the Act and the rules and orders of the Federal Communications Commission and the Florida Public Service Commission.

35. Local Service Resale

The rates that AT&T shall pay to BellSouth for resold Local Services shall be BellSouth's Retail Rates less the applicable discount. The following discount will apply to all Telecommunications Services available for resale in Florida.

Residential Service	21.83%
Business Service:	16.81%

36. Unbundled Network Elements

The prices that AT&T shall pay to BellSouth for Unbundled Network Elements are set forth in Table 1.

36.1 Charges for Multiple Network Elements

Any BellSouth non-recurring and recurring charges shall not include duplicate charges or charges for functions or activities that AT&T does not need when two or more Network Elements are combined in a single order. BellSouth and AT&T shall work together to mutually agree upon the total non-recurring and recurring charge(s) to be paid by AT&T when ordering multiple Network Elements. If the parties cannot agree to the total non-recurring and recurring charge(s) to be paid by AT&T when ordering multiple Network Elements within sixty (60) days of the Effective Date, either party may petition the Florida Public Service Commission to settle the disputed charge or charges.

37. Compensation For Call and Transport Termination

The prices that AT&T and BellSouth shall pay are set forth in Table 1.

38. Ancillary Functions

38.1 Collocation - The prices that AT&T shall pay to BellSouth are set forth in Table 2.

*LIB*  
FL6/10/97

38.2 Rights-of-Way - The prices that AT&T shall pay to BellSouth are set forth in Table 3.

38.3 Poles, Ducts and Conduits - The prices that AT&T shall pay to BellSouth are set forth in Table 4.

39 Local Number Portability

The prices for interm number portability are set forth in Table 5.

40 Recorded Usage Data

The prices for recorded usage data are set forth in Table 6.

41 Electronic Interfaces

Each party shall bear its own cost of developing and implementing Electronic Interface Systems because those systems will benefit all carriers. If a system or process is developed exclusively for certain carriers, however, those costs shall be recovered from the carrier who is requesting the customized system.

TABLE 1

## UNBUNDLED NETWORK ELEMENTS

Network Interface Device, Per Month	SC 73 (interim rate)
Loops, including NID	
2 wire, per month	\$ 17.00
NRC First	\$140.00
NRC Add'l	\$ 42.00
4 wire, per month	\$ 30.00
NRC First	\$141.00
NRC Add'l	\$ 43.00
2 wire ISDN, per month	\$ 40.00
NRC First	\$306.00
NRC Add'l	\$283.00
DS1, per month	\$ 80.00
NRC First	\$540.00
NRC Add'l	\$465.00
Unbundled Loop Channelization System (DS1 to VG)	
Per system, per month	\$480.00
NRC, First	\$350.00
NRC, Add'l	\$ 90.00
Per voice interface, per month	\$ 1.50
NRC, First	\$ 5.75
NRC, Add'l	\$ 5.50

WLB  
FL6/FO/97

<b>End Office Switching</b>	
<b>Pans</b>	
2 wire	\$ 2.00
NRC First	\$38.00
NRC Add'l	\$15.00
4 wire	\$10.00 (interm rate)
NRC First	\$38.00 (interm rate)
NRC Add'l	\$15.00 (interm rate)
2 wire ISDN	\$13.00
NRC First	\$88.00
NRC Add'l	\$66.00
2 wire DID	TBD
NRC First	TBD
NRC Add'l	TBD
4 wire ISDN	TBD
NRC First	TBD
NRC Add'l	TBD
4 wire DS1	\$125.00
NRC First	\$112.00
NRC Add'l	\$ 91.00
<b>Usage</b>	
Initial Minute	\$0.0175
Additional Minutes	\$0.005
Features, functions, capabilities	No additional charge

*JLB*  
FL6/10/97

<b>Operator Systems</b>	
Operator Call Handling-Station & Person	\$1.00 per minute
Automated Call Handling	\$0.10 per call attempt
Directory Assistance	\$0.25 per call
DA Call Completion	\$0.03 per call attempt
Intercept	\$0.01 per call
Busy Line Verification	\$0.80 per call
Emergency Interrupt	\$1.00 per call
<b>Directory Assistance</b>	
<b>DA Database</b>	
per listing	\$0.001
monthly	\$100.00
<b>Direct access to DA service</b>	
per query	\$0.01
monthly	\$5,000.00
<b>NRC, service establish charge</b>	<b>\$820.00</b>
<b>DA transport</b>	
switched local channel	\$133.81 (interim rate)
<b>NRC, first</b>	<b>\$866.97 (interim rate)</b>
<b>NRC, add'l</b>	<b>\$486.83 (interim rate)</b>
<b>switched dedicated DS1 level</b>	
per mile	\$16.75 (interim rate)
per facility termination	\$59.75 (interim rate)
<b>NRC</b>	<b>\$100.49 (interim rate)</b>
switched common	

per DA call	\$0.0003
per DA call per mile	\$0.00001
tandem switching	
per DA call	\$0.00055
<b>Dedicated Transport</b>	
DS1, facility termination	\$ 59.75
DS1, per mile	\$ 1.60
NRC	\$100.49 (interim rate)
<b>Common Transport</b>	
Facility termination, per MOU	\$0.0005
Per mile, per MOU	\$0.000012
<b>Tandem Switching</b>	\$0.00029 per minute
<b>Signaling Links</b>	
Link	\$5.00 per link, per month
non-recurring	\$400.00
Link termination	\$113.00



Signal Transfer Points	
SUP	\$0.00001 per message
TCAP	\$0.00004 per message
Usage surrogate	\$64.00 per month
Service Control Points	
LIDB (1)	TBD
Toll Free Database (1)	TBD
AIN, per message	\$0.00004 (interim rate)
AIN, Service Creation Tools (1)	TBD
AIN, Mediation (1)	TBD
(1) BellSouth and AT&T shall negotiate rates for this offering. If agreement is not reached within sixty (60) days of the Effective Date, either party may petition the Florida PSC to settle the disputed charge or charges.	
Call Transport and Termination	
Direct End Office interconnection	\$ .002 per MOU
Interconnection at the Tandem Switch,	
• Tandem switch + transport	\$ .00125 per MOU
• End Office Switch	\$ .00200 per MOU
• Combined	\$ .00325 per MOU

TABLE 2

### PHYSICAL AND VIRTUAL COLLOCATION

The following are interim rates, subject to true-up based on permanent rates. Permanent rates will be set once BellSouth files appropriate TSLRIC cost studies and such studies are reviewed and approved by the Florida PSC.

#### PHYSICAL COLLOCATION

Application - Per Arrangement/Per Location-Nonrecurring	\$3,100.00
Space Preparation Fee - Nonrecurring	ICB
Space Construction Fee - Nonrecurring	\$3,750.00
Cable Installation - Per Entrance Cable	\$2,750.00
Floor Space Zone A, Per Square Foot, Per Month	\$4.28
Floor Space Zone B, Per Square Foot, Per Month	\$4.09
Power Per AMP, Per Month	\$3.86
Cable Support Structure, Per Entrance Cable	\$13.35
POT Bay (Optional Point of Termination Bay)	
Per 2-Wire Cross - Connect, Per Month	\$0.18
Per 4-Wire Cross - Connect, Per Month	\$0.44
Per DS1 Cross - Connect, Per Month	\$0.44
Per DS3 Cross - Connect, Per Month	\$3.66
Cross-Connects	
2-Wire Analog, Per Month	\$0.30
4-Wire Analog, Per Month	\$0.50
Nonrecurring 2-wire and 4-wire	\$9.25
DS1, Per Month	\$3.07
Nonrecurring - First/Additional	\$113.75/14.25
DS3, Per Month	\$39.64
Nonrecurring - First/Additional	\$113.75/14.25
Security Escort	
Basic - 1st half hour	\$41.00
Overtime - 1st half hour	\$48.00
Premium - 1st half hour	\$55.00
Basic - additional	\$25.00
Overtime - additional	\$30.00
Premium - additional	\$35.00

VIRTUAL COLLOCATION

Rates tariffed by BellSouth in its FCC Tariff No. 1, Section 20.

*llb*  
FL6/10/97

**RIGHTS OF WAY**

BellSouth shall provide access to rights-of-way at rates that are consistent with Section 224 of the Telecommunications Act of 1934. To this end, BellSouth shall file appropriate rates to be approved by the Florida Public Service Commission.

*UB*  
FL6/10/97

## TABLE 4

## POLE ATTACHMENTS, CONDUIT AND DUCT OCCUPANCY

Pole Attachment	\$4.20 per attachment, per year
Conduit, per foot	\$0.56 per foot, per year
Work performed by BellSouth Employee, per hour	Labor rate as developed in accordance with FCC Accounting Rules for work performed by BellSouth employees.

UB  
FL5/10/97

## TABLE 5

## LOCAL NUMBER PORTABILITY

AT&T and BellSouth shall pay its own costs in the provision of interim number portability. AT&T and BellSouth shall track their costs of providing interim number portability with sufficient detail to verify the costs, in order to facilitate the Florida PSC's consideration of recovery of these costs in Docket No. 950737-TP.

*MB*  
FL5/10/97

## TABLE 6

(Interim Rates Pending Further Negotiation)

RECORDED USAGE DATA

Recording Services (only applied to unbundled operator services messages), per message	\$ .008
Message Distribution, per message	\$ .004
Data Transmission, per message	\$ .001

UB  
FL6/10/97

42 Execution of the Interconnection Agreement by either Party does not confirm or infer that the executing Party agrees with any decision(s) issued pursuant to the Telecommunications Act of 1996 and the consequences of those decisions on specific language in this Agreement. Neither Party waives its rights to appeal or otherwise challenge any such decision(s) and each Party reserves all of its rights to pursue any and all legal and/or equitable remedies, including appeals of any such decision(s). If such appeals or challenges result in changes in the decision(s), the Parties agree that appropriate modifications to this Agreement will be made promptly to make its terms consistent with those changed decision(s).

IN WITNESS WHEREOF, the Parties have executed this Agreement through their authorized representatives.

AT&T COMMUNICATIONS OF THE SOUTHERN STATES, INC.

BELLSOUTH TELECOMMUNICATIONS, INC.

By: William J. Carroll  
William J. Carroll  
Vice President

By: Jerry D. Hendrix  
Jerry D. Hendrix  
Director  
Interconnection Services/  
Pricing

June 10, 1997  
Date

June 10, 1997  
Date

DUPLICATE ORIGINAL

MB  
FL6/10/97



TABLE OF CONTENTS

ALTERNATIVE DISPUTE RESOLUTION

1. Purpose ..... 1

2. Exclusive Remedy ..... 1

3. Informal Resolution of Disputes ..... 1

4. Initiation of an Arbitration ..... 2

5. Governing Rules for Arbitration ..... 2

6. Appointment and Removal of Arbitrators for Non-Service-Affecting Disputes ..... 2

7. Duties and Powers of the Arbitrators ..... 3

8. Discovery and Proceedings ..... 3

9. Resolution of Service-Affecting Disputes ..... 4

10. Privileges ..... 6

11. Location of Hearing ..... 7

12. Decision ..... 7

13. Fees ..... 7

14. Confidentiality ..... 7

15. Service of Process ..... 8

## ALTERNATIVE DISPUTE RESOLUTION

### Purpose

Attachment 1 provides for the expeditious, economical, and equitable resolution of disputes between BellSouth and AT&T arising under this Agreement.

### 2. Exclusive Remedy

- 2.1 Negotiation and arbitration under the procedures provided herein shall be the exclusive remedy for all disputes between BellSouth and AT&T arising under or related to this Agreement including its breach, except for: (i) disputes arising pursuant to Attachment 6, Connectivity Billing; and (ii) disputes or matters for which the Telecommunications Act of 1996 specifies a particular remedy or procedure. Except as provided herein, BellSouth and AT&T hereby renounce all recourse to litigation and agree that the award of the arbitrators shall be final and subject to no judicial review, except on one or more of those grounds specified in the Federal Arbitration Act (9 USC §§ 1 et seq.), as amended, or any successor provision thereto.
- 2.1.1 If, for any reason, certain claims or disputes are deemed to be non-arbitrable, the non-arbitrability of those claims or disputes shall in no way affect the arbitrability of any other claims or disputes.
- 2.1.2 If, for any reason, the Federal Communications Commission or any other federal or state regulatory agency exercises jurisdiction over and decides any dispute related to this Agreement or to any BellSouth tariff and, as a result, a claim is adjudicated in both an agency proceeding and an arbitration proceeding under this Attachment 1, the following provisions shall apply:
- 2.1.2.1 To the extent required by law, the agency ruling shall be binding upon the Parties for the limited purposes of regulation within the jurisdiction and authority of such agency.
- 2.1.2.2 The arbitration ruling rendered pursuant to this Attachment 1 shall be binding upon the Parties for purposes of establishing their respective contractual rights and obligations under this Agreement, and for all other purposes not expressly precluded by such agency ruling.

3 Informal Resolution of Disputes

3.1 The Parties to this Agreement shall submit any and all disputes between BellSouth and AT&T for resolution to an Inter-Company Review Board consisting of one representative from AT&T at the Director-or-above level and one representative from BellSouth at the Vice-President-or-above level (or at such lower level as each Party may designate).

3.2 The Parties may enter into a settlement of any dispute at any time.

4 Initiation of an Arbitration

Except for Disputes Affecting Service, if the Inter-Company Review Board is unable to resolve the dispute within thirty (30) days (or such longer period as agreed to in writing by the Parties) of such submission, and the Parties have not otherwise entered into a settlement of their dispute, either Party may initiate an arbitration in accordance with the CPR Institute for Dispute Resolution ("CPR") Rules for Non-Administered Arbitration and business disputes ("the CPR Rules").

If the Inter-Company Review Board provided for in Section 3 of this Attachment 1 is unable to resolve a Dispute Affecting Service within two (2) business days (or such longer period as agreed to in writing by the Parties) of such submission, and the Parties have not otherwise entered into a settlement of their dispute, either Party, may, through its representative on the Inter-Company Review Board, request arbitration of what in good faith is believed to be a Dispute Affecting Service in accordance with the requirements of Section 9 of this Attachment 1, with the consent of the other party, which consent shall not be unreasonably withheld. Any dispute not resolved in accordance with Section 9 of this Attachment 1 shall be resolved as if it were not a Dispute Affecting Service.

5. Governing Rules for Arbitration

5.1 The rules set forth below and the CPR Rules shall govern all arbitration proceedings initiated pursuant to this Attachment; however, such arbitration proceedings shall not be conducted under the auspices of the CPR Rules unless the Parties mutually agree. Where any of the rules set forth herein conflict with the rules of the CPR Rules, the rules set forth in this Attachment shall prevail.

6 Appointment and Removal of Arbitrators for the Disputes other than the Disputes Affecting Service Process

6.1 Each arbitration conducted pursuant to this Section shall be conducted before a panel of three Arbitrators, each of whom shall meet the qualifications set forth herein. Each Arbitrator shall be impartial, shall not have been employed by or affiliated with any of the Parties hereto or any of their respective Affiliates and shall possess substantial legal, accounting, telecommunications business or other professional experience relevant to the issues in dispute in the arbitration as stated in the notice initiating such proceeding. The panel of arbitrators shall be selected as provided in the CPR Rules.

6.2 The Parties may, by mutual written agreement, remove an Arbitrator at any time, and shall provide prompt written notice of removal to such Arbitrator

6.3 In the event that an Arbitrator resigns, is removed pursuant to Section 6.2 of this Attachment 1, or becomes unable to discharge his or her duties, the Parties shall, by mutual written Agreement, appoint a replacement Arbitrator within thirty (30) days after such resignation, removal, or inability, unless a different time period is mutually agreed upon in writing by the Parties. Any matters pending before the Arbitrator at the time he or she resigns, is removed, or becomes unable to discharge his or her duties, will be assigned to the replacement Arbitrator as soon as the replacement Arbitrator is appointed.

6.4 **DELETED**

7. Duties and Powers of the Arbitrators

The Arbitrators shall receive complaints and other permitted pleadings, oversee discovery, administer oaths and subpoena witnesses pursuant to the United States Arbitration Act, hold hearings, issue decisions, and maintain a record of proceedings. The Arbitrators shall have the power to award any remedy or relief that a court with jurisdiction over this Agreement could order or grant, including, without limitation, the awarding of damages, pre-judgment interest, specific performance of any obligation created under the Agreement, issuance of an injunction, or imposition of sanctions for abuse or frustration of the arbitration process, except that the Arbitrators may not: (i) award punitive damages; (ii) or any remedy rendered unavailable to the Parties pursuant to Section 10.3 of the General Terms and Conditions of the Agreement; or (iii) limit, expand, or otherwise modify the terms of this Agreement.

8. Discovery and Proceedings

gmr

- 9.2.4 In the event that an Arbitrator resigns, is removed pursuant to Section 9.2.3 of this Attachment 1, or becomes unable to discharge his or her duties, the Parties shall, by mutual written Agreement, appoint a replacement Arbitrator within thirty (30) days after such resignation, removal, or inability, unless a
- 9.2.3 The Parties may, by mutual written agreement, remove an Arbitrator at any time, and shall provide prompt written notice of removal to such Arbitrator.
- 9.2.2 The Parties shall appoint three (3) Arbitrators who will serve for the term of this Agreement, unless removed pursuant to Section 9.2.3 of this Attachment 1. The appointment and the order in which Arbitrators shall preside over Disputes Affecting Service will be made by mutual agreement in writing within thirty (30) days after the Effective Date.
- 9.2.1 A sole Arbitrator will preside over each dispute submitted for arbitration under this Section 9.

**Appointment and Removal of Arbitrator**

- 9.1 Purpose
- This Section 9 describes the procedures for an expedited resolution of disputes between BellSouth and AT&T arising under this Agreement which directly affect the ability of a Party to provide uninterrupted, high quality services to its customers at the time of the dispute and which cannot be resolved using the procedures for informal resolution of disputes contained in this attachment of the Agreement.

**Resolution of Disputes Affecting Service**

- 3.2 The Parties shall facilitate the arbitration by: (i) making available to one another and to the Arbitrators, on as expedited a basis as is practicable, for examination, deposition, inspection and extraction all documents, books, records and personnel under their control if determined by the Arbitrators to be relevant to the dispute; (ii) conducting arbitration hearings to the greatest extent possible on successive days; and (iii) observing strictly the time periods established by the CPR Rules or by the Arbitrators for submission of evidence or briefs.
- 3.1 BellSouth and AT&T shall attempt in good faith to agree on a plan for discovery. Should they fail to agree, either BellSouth or AT&T may request a joint meeting or conference call with the Arbitrators. The Arbitrators shall resolve any disputes between BellSouth and AT&T and such resolution with respect to the scope, manner, and timing of discovery shall be final and binding.

The Arbitrator will schedule a hearing on the Complaint to take place within twenty (20) business days after service of the Complaint. However, if mutually agreed to by the Parties, a hearing may be waived and the decision of the Arbitrator will be based upon the papers filed by the Parties.

9.7.1

**Hearing**

9.7

The Parties shall cooperate on discovery matters as provided in Section 8 of this Attachment 1, but following expedited procedures.

**Discovery**

9.6

A reply is permitted to be filed by the Complaining Party within three (3) business days of service of the response. The reply must be limited to those matters raised in the response.

**Reply to Complaint**

9.5

A response to the Complaint must be filed within five (5) business days after service of the Complaint.

**Response to Complaint**

9.4

A Complaint may be in letter or memorandum form and must specifically describe the action or inaction of a Party in dispute and identify with particularity how the complaining Party's service to its customers is affected.

9.3.3

Each Complaint will concern only the claims relating to an act or failure to act (or series of related acts or failures to act) of a Party which affect the Complaining Party's ability to offer a specific service (or group of related services) to its customers.

9.3.2

A proceeding for arbitration under this Section 9 will be commenced by a Party ("Complaining Party") after following the process provided for in Section 4 of this Attachment 1 by filing a complaint with the Arbitrator and simultaneously providing a copy to the other Party ("Complainant").

9.3.1

**Initiation of Disputes Affecting Service Process.**

9.3

different time period is mutually agreed upon in writing by the Parties. Any matters pending before the Arbitrator at the time he or she resigns, is removed, or becomes unable to discharge his or her duties, will be assigned to the Arbitrator whose name appears next in the alphabet.

- 9.7.2 The hearing will be limited to four (4) days, with each Party allocated no more than two (2) days, including cross examination by the other Party, to present its evidence and arguments. For extraordinary reasons, including the need for extensive cross-examination, the Arbitrator may allocate more time for the hearing.

In order to focus the issues for purposes of the hearing, to present initial views concerning the issues, and to facilitate the presentation of evidence, the Arbitrator has the discretion to conduct a telephone prehearing conference at a mutually convenient time, but in no event later than three (3) days prior to any scheduled hearing.

Each Party may introduce evidence and call witnesses it has previously identified in its witness and exhibit lists. The witness and exhibit lists must be furnished to the other Party at least three (3) days prior to commencement of the hearing. The witness list will disclose the substance of each witness' expected testimony. The exhibit list will identify by name (author and recipient), date, title and any other identifying characteristics the exhibits to be used at the arbitration. Testimony from witnesses not listed on the witness list or exhibits not listed on the exhibit list may not be presented in the hearing.

- 9.7.3 The Parties will make reasonable efforts to stipulate to undisputed facts prior to the date of the hearing.

- 9.7.4 Witnesses will testify under oath and a complete transcript of the proceeding, together with all pleadings and exhibits, shall be maintained by the Arbitrator.

## 9.8 Decision

- 9.8.1 The Arbitrator will issue and serve his or her decision on the Parties within five (5) business days of the close of the hearing or receipt of the hearing transcript, whichever is later.

- 9.8.2 The Parties agree to take the actions necessary to implement the decision of the Arbitrator immediately upon receipt of the decision.

## 10. Privileges

- 10.1 Although conformity to certain legal rules of evidence may not be necessary in connection arbitrations initiated pursuant to this Attachment, the Arbitrators shall, in all cases, apply the attorney-client privilege and the work product immunity.

- 10.2 At no time, for any purposes, may a Party introduce into evidence or inform the Arbitrators of any statement or other action of a Party in connection with

gmr

BellSouth, AT&T, and the Arbitrator(s) will treat any arbitration proceeding, including the hearings and conferences, discovery, or other related events, as confidential, except as necessary in connection with a judicial challenge to, or

14.1

Confidentiality

14.

In an action to enforce or confirm a decision of the Arbitrator(s), the prevailing Party shall be entitled to its reasonable attorneys' fees, expert fees, costs, and expenses.

13.2

The Arbitrator(s) fees and expenses that are directly related to a particular proceeding shall be paid by the losing Party. In cases where the Arbitrator(s) determines that neither Party has, in some material respect, completely prevailed or lost in a proceeding, the Arbitrator(s) shall, in his or her discretion, apportion expenses to reflect the relative success of each Party. Those fees and expenses not directly related to a particular proceeding shall be shared equally. In the event that the Parties settle a dispute before the Arbitrator(s) reaches a decision with respect to that dispute, the Settlement Agreement must specify how the Arbitrator(s) fees for the particular proceeding will be apportioned.

13.1

Fees

13.

The Arbitrator(s) decision and award shall be final and binding, and shall be in writing unless the Parties mutually agree to waive the requirement of a written opinion. Judgment upon the award rendered by the Arbitrator(s) may be entered in any court having jurisdiction thereof. Either Party may apply to the United States District Court for the district in which the hearing occurred for an order enforcing the decision. Except for Disputes Affecting Service, the Arbitrators shall make their decision within ninety (90) days of the initiation of proceedings pursuant to Section 4 of this Attachment, unless the Parties mutually agree otherwise.

12.

Decision

Unless both Parties agree otherwise, any hearing under this Attachment shall take place in Atlanta, Georgia.

Location of Hearing

Negotiations between the Parties pursuant to the Informal Resolution of Disputes provision of this Attachment.



enforcement of, an award, or unless otherwise required by an order or lawful process of a court or governmental body

- 14.2 In order to maintain the privacy of all arbitration conferences and hearings, the Arbitrator(s) shall have the power to require the exclusion of any person other than a Party, counsel thereto, or other essential persons.
- 14.3 To the extent that any information or materials disclosed in the course of an arbitration proceeding contains proprietary or confidential information of either Party, it shall be safeguarded in accordance with Section 18 of the General Terms and Conditions of the Agreement. However, nothing in Section 18 of the General Terms and Conditions of the Agreement shall be construed to prevent either Party from disclosing the other Party's Information to the Arbitrator in connection with or in anticipation of an arbitration proceeding. In addition, the Arbitrators may issue orders to protect the confidentiality of proprietary information, trade secrets, or other sensitive information.

15. **Service of Process**

Except as provided in Section 9.3.1 of this Attachment 1, service may be made by submitting one copy of all pleadings and attachments and any other documents requiring service to each Party and one copy to the Arbitrator. Service shall be deemed made (i) upon receipt if delivered by hand; (ii) after three (3) business days if sent by first class U.S. mail; (iii) the next business day if sent by overnight courier service; or (iv) upon confirmed receipt if transmitted by facsimile. If service is by facsimile, a copy shall be sent the same day by hand delivery, first class U.S. mail, or overnight courier service.

- 15.1 Service by AT&T to BellSouth and by BellSouth to AT&T at the address designated for delivery of notices in this Agreement shall be deemed to be service to BellSouth or AT&T, respectfully.

TABLE OF CONTENTS

ALTERNATIVE DISPUTE RESOLUTION

1. Purpose ..... 1

2. Exclusive Remedy ..... 1

3. Informal Resolution of Disputes ..... 1

4. Initiation of an Arbitration ..... 2

5. Governing Rules for Arbitration ..... 2

6. Appointment and Removal of Arbitrators for Non-Service-Affecting Disputes ..... 2

7. Duties and Powers of the Arbitrators ..... 3

8. Discovery and Proceedings ..... 3

9. Resolution of Service-Affecting Disputes ..... 4

10. Privileges ..... 6

11. Location of Hearing ..... 7

12. Decision ..... 7

13. Fees ..... 7

14. Confidentiality ..... 7

15. Service of Process ..... 8

*UB*  
FL6/10/97

## ALTERNATIVE DISPUTE RESOLUTION

### Purpose

Attachment 1 provides for the expeditious, economical, and equitable resolution of disputes between BellSouth and AT&T arising under this Agreement.

### 2. Exclusive Remedy

- 2.1 Negotiation and arbitration under the procedures provided herein shall be the exclusive remedy for all disputes between BellSouth and AT&T arising under or related to this Agreement including its breach, except for: (i) disputes arising pursuant to Attachment 6, Connectivity Billing; and (ii) disputes or matters for which the Telecommunications Act of 1996 specifies a particular remedy or procedure. Except as provided herein, BellSouth and AT&T hereby renounce all recourse to litigation and agree that the award of the arbitrators shall be final and subject to no judicial review, except on one or more of those grounds specified in the Federal Arbitration Act (9 USC §§ 1 et seq.), as amended, or any successor provision thereto.
- 2.1.1 If, for any reason, certain claims or disputes are deemed to be non-arbitrable, the non-arbitrability of those claims or disputes shall in no way affect the arbitrability of any other claims or disputes.
- 2.1.2 If, for any reason, the Federal Communications Commission or any other federal or state regulatory agency exercises jurisdiction over and decides any dispute related to this Agreement or to any BellSouth tariff and, as a result, a claim is adjudicated in both an agency proceeding and an arbitration proceeding under this Attachment 1, the following provisions shall apply:
- 2.1.2.1 To the extent required by law, the agency ruling shall be binding upon the Parties for the limited purposes of regulation within the jurisdiction and authority of such agency.
- 2.1.2.2 The arbitration ruling rendered pursuant to this Attachment 1 shall be binding upon the Parties for purposes of establishing their respective contractual rights and obligations under this Agreement, and for all other purposes not expressly precluded by such agency ruling.

3 Informal Resolution of Disputes

3.1 The Parties to this Agreement shall submit any and all disputes between BellSouth and AT&T for resolution to an Inter-Company Review Board consisting of one representative from AT&T at the Director-or-above level and one representative from BellSouth at the Vice-President-or-above level (or at such lower level as each Party may designate).

3.2 The Parties may enter into a settlement of any dispute at any time.

4 Initiation of an Arbitration

Except for Disputes Affecting Service, if the Inter-Company Review Board is unable to resolve the dispute within thirty (30) days (or such longer period as agreed to in writing by the Parties) of such submission, and the Parties have not otherwise entered into a settlement of their dispute, either Party may initiate an arbitration in accordance with the CPR Institute for Dispute Resolution ("CPR") Rules for Non-Administered Arbitration and business disputes ("the CPR Rules").

If the Inter-Company Review Board provided for in Section 3 of this Attachment 1 is unable to resolve a Dispute Affecting Service within two (2) business days (or such longer period as agreed to in writing by the Parties) of such submission, and the Parties have not otherwise entered into a settlement of their dispute, either Party, may, through its representative on the Inter-Company Review Board, request arbitration of what in good faith is believed to be a Dispute Affecting Service in accordance with the requirements of Section 9 of this Attachment 1, with the consent of the other party, which consent shall not be unreasonably withheld. Any dispute not resolved in accordance with Section 9 of this Attachment 1 shall be resolved as if it were not a Dispute Affecting Service.

5 Governing Rules for Arbitration

5.1 The rules set forth below and the CPR Rules shall govern all arbitration proceedings initiated pursuant to this Attachment; however, such arbitration proceedings shall not be conducted under the auspices of the CPR Rules unless the Parties mutually agree. Where any of the rules set forth herein conflict with the rules of the CPR Rules, the rules set forth in this Attachment shall prevail.

6. Appointment and Removal of Arbitrators for the Disputes other than the Disputes Affecting Service Process

6.1 Each arbitration conducted pursuant to this Section shall be conducted before a panel of three Arbitrators, each of whom shall meet the qualifications set forth herein. Each Arbitrator shall be impartial, shall not have been employed by or affiliated with any of the Parties hereto or any of their respective Affiliates and shall possess substantial legal, accounting, telecommunications business or other professional experience relevant to the issues in dispute in the arbitration as stated in the notice initiating such proceeding. The panel of arbitrators shall be selected as provided in the CPR Rules.

6.2 The Parties may, by mutual written agreement, remove an Arbitrator at any time, and shall provide prompt written notice of removal to such Arbitrator.

6.3 In the event that an Arbitrator resigns, is removed pursuant to Section 6.2 of this Attachment 1, or becomes unable to discharge his or her duties, the Parties shall, by mutual written Agreement, appoint a replacement Arbitrator within thirty (30) days after such resignation, removal, or inability, unless a different time period is mutually agreed upon in writing by the Parties. Any matters pending before the Arbitrator at the time he or she resigns, is removed, or becomes unable to discharge his or her duties, will be assigned to the replacement Arbitrator as soon as the replacement Arbitrator is appointed.

6.4 **DELETED**

7. Duties and Powers of the Arbitrators

The Arbitrators shall receive complaints and other permitted pleadings, oversee discovery, administer oaths and subpoena witnesses pursuant to the United States Arbitration Act, hold hearings, issue decisions, and maintain a record of proceedings. The Arbitrators shall have the power to award any remedy or relief that a court with jurisdiction over this Agreement could order or grant, including, without limitation, the awarding of damages, pre-judgment interest, specific performance of any obligation created under the Agreement, issuance of an injunction, or imposition of sanctions for abuse or frustration of the arbitration process, except that the Arbitrators may not: (i) award punitive damages; (ii) or any remedy rendered unavailable to the Parties pursuant to Section 10.3 of the General Terms and Conditions of the Agreement; or (iii) limit, expand, or otherwise modify the terms of this Agreement.

8. Discovery and Proceedings

gr

9.2.1 A sole Arbitrator will preside over each dispute submitted for arbitration under this Section 9.

9.2.2 The Parties shall appoint three (3) Arbitrators who will serve for the term of this Agreement, unless removed pursuant to Section 9.2.3 of this Attachment 1. The appointment and the order in which Arbitrators shall preside over Disputes Affecting Service will be made by mutual agreement in writing within thirty (30) days after the Effective Date.

9.2.3 The Parties may, by mutual written agreement, remove an Arbitrator at any time, and shall provide prompt written notice of removal to such Arbitrator.

9.2.4 In the event that an Arbitrator resigns, is removed pursuant to Section 9.2.3 of this Attachment 1, or becomes unable to discharge his or her duties, the Parties shall, by mutual written Agreement, appoint a replacement Arbitrator within thirty (30) days after such resignation, removal, or inability, unless a

9.2 Appointment and Removal of Arbitrator

9.1 Purpose

This Section 9 describes the procedures for an expedited resolution of disputes between BellSouth and AT&T arising under this Agreement which directly affect the ability of a Party to provide uninterrupted, high quality services to its customers at the time of the dispute and which cannot be resolved using the procedures for informal resolution of disputes contained in this attachment of the Agreement.

9. Resolution of Disputes Affecting Service

3.2 The Parties shall facilitate the arbitration by: (i) making available to one another and to the Arbitrators, on as expedited a basis as is practicable, for examination, deposition, inspection and extraction all documents, books, records and personnel under their control if determined by the Arbitrators to be relevant to the dispute; (ii) conducting arbitration hearings to the greatest extent possible on successive days; and (iii) observing strictly the time periods established by the CPR Rules or by the Arbitrators for submission of evidence or briefs.

3.1 BellSouth and AT&T shall attempt in good faith to agree on a plan for discovery. Should they fail to agree, either BellSouth or AT&T may request a joint meeting or conference call with the Arbitrators. The Arbitrators shall resolve any disputes between BellSouth and AT&T and such resolution with respect to the scope, manner, and timing of discovery shall be final and binding.

different time period is mutually agreed upon in writing by the Parties. Any matters pending before the Arbitrator at the time he or she resigns, is removed, or becomes unable to discharge his or her duties, will be assigned to the Arbitrator whose name appears next in the alphabet.

**9.3 Initiation of Disputes Affecting Service Process.**

9.3.1 A proceeding for arbitration under this Section 9 will be commenced by a Party ("Complaining Party") after following the process provided for in Section 4 of this Attachment 1 by filing a complaint with the Arbitrator and simultaneously providing a copy to the other Party ("Complaint").

9.3.2 Each Complaint will concern only the claims relating to an act or failure to act (or series of related acts or failures to act) of a Party which affect the Complaining Party's ability to offer a specific service (or group of related services) to its customers.

9.3.3 A Complaint may be in letter or memorandum form and must specifically describe the action or inaction of a Party in dispute and identify with particularity how the complaining Party's service to its customers is affected.

**9.4 Response to Complaint**

A response to the Complaint must be filed within five (5) business days after service of the Complaint.

**9.5 Reply to Complaint**

A reply is permitted to be filed by the Complaining Party within three (3) business days of service of the response. The reply must be limited to those matters raised in the response.

**9.6 Discovery**

The Parties shall cooperate on discovery matters as provided in Section 8 of this Attachment 1, but following expedited procedures.

**9.7 Hearing**

9.7.1 The Arbitrator will schedule a hearing on the Complaint to take place within twenty (20) business days after service of the Complaint. However, if mutually agreed to by the Parties, a hearing may be waived and the decision of the Arbitrator will be based upon the papers filed by the Parties.

9.7.2 The hearing will be limited to four (4) days, with each Party allocated no more than two (2) days, including cross examination by the other Party to present its evidence and arguments. For extraordinary reasons, including the need for extensive cross-examination, the Arbitrator may allocate more time for the hearing.

In order to focus the issues for purposes of the hearing, to present initial views concerning the issues, and to facilitate the presentation of evidence, the Arbitrator has the discretion to conduct a telephone prehearing conference at a mutually convenient time, but in no event later than three (3) days prior to any scheduled hearing.

Each Party may introduce evidence and call witnesses it has previously identified in its witness and exhibit lists. The witness and exhibit lists must be furnished to the other Party at least three (3) days prior to commencement of the hearing. The witness list will disclose the substance of each witness expected testimony. The exhibit list will identify by name (author and recipient), date, title and any other identifying characteristics the exhibits to be used at the arbitration. Testimony from witnesses not listed on the witness list or exhibits not listed on the exhibit list may not be presented in the hearing.

9.7.3 The Parties will make reasonable efforts to stipulate to undisputed facts prior to the date of the hearing.

9.7.4 Witnesses will testify under oath and a complete transcript of the proceeding, together with all pleadings and exhibits, shall be maintained by the Arbitrator.

9.8 Decision

9.8.1 The Arbitrator will issue and serve his or her decision on the Parties within five (5) business days of the close of the hearing or receipt of the hearing transcript, whichever is later.

9.8.2 The Parties agree to take the actions necessary to implement the decision of the Arbitrator immediately upon receipt of the decision.

**Privileges**

10. Although conformity to certain legal rules of evidence may not be necessary in connection arbitrations initiated pursuant to this Attachment, the Arbitrators shall, in all cases, apply the attorney-client privilege and the work product immunity.

10.2 At no time, for any purposes, may a Party introduce into evidence or inform the Arbitrators of any statement or other action of a Party in connection with

FLS/10/97  
*gn*



negotiations between the Parties pursuant to the Informal Resolution of Disputes provision of this Attachment 1

11. Location of Hearing

Unless both Parties agree otherwise, any hearing under this Attachment 1 shall take place in Atlanta, Georgia.

12. Decision

The Arbitrator(s) decision and award shall be final and binding, and shall be in writing unless the Parties mutually agree to waive the requirement of a written opinion. Judgment upon the award rendered by the Arbitrator(s) may be entered in any court having jurisdiction thereof. Either Party may apply to the United States District Court for the district in which the hearing occurred for an order enforcing the decision. Except for Disputes Affecting Service, the Arbitrators shall make their decision within ninety (90) days of the initiation of proceedings pursuant to Section 4 of this Attachment, unless the Parties mutually agree otherwise.

13. Fees

13.1 The Arbitrator(s) fees and expenses that are directly related to a particular proceeding shall be paid by the losing Party. In cases where the Arbitrator(s) determines that neither Party has, in some material respect, completely prevailed or lost in a proceeding, the Arbitrator(s) shall, in his or her discretion, apportion expenses to reflect the relative success of each Party. Those fees and expenses not directly related to a particular proceeding shall be shared equally. In the event that the Parties settle a dispute before the Arbitrator(s) reaches a decision with respect to that dispute, the Settlement Agreement must specify how the Arbitrator(s)' fees for the particular proceeding will be apportioned.

13.2 In an action to enforce or confirm a decision of the Arbitrator(s), the prevailing Party shall be entitled to its reasonable attorneys' fees, expert fees, costs, and expenses.

14. Confidentiality

14.1 BellSouth, AT&T, and the Arbitrator(s) will treat any arbitration proceeding, including the hearings and conferences, discovery, or other related events, as confidential, except as necessary in connection with a judicial challenge to, or

gmr

- 15.1 Service by AT&T to BellSouth and by BellSouth to AT&T at the address designated for delivery of notices in this Agreement shall be deemed to be service to BellSouth or AT&T, respectively.
- 15. Except as provided in Section 9.3.1 of this Attachment 1, service may be made by submitting one copy of all pleadings and attachments and any other documents requiring service to each Party and one copy to the Arbitrator. Service shall be deemed made (i) upon receipt if delivered by hand; (ii) after three (3) business days if sent by first class U.S. mail; (iii) the next business day if sent by overnight courier service; or (iv) upon confirmed receipt if transmitted by facsimile. If service is by facsimile, a copy shall be sent the same day by hand delivery, first class U.S. mail, or overnight courier service.
- 15. Service of Process
- 14.3 To the extent that any information or materials disclosed in the course of an arbitration proceeding contains proprietary or confidential information of either Party, it shall be safeguarded in accordance with Section 18 of the General Terms and Conditions of the Agreement. However, nothing in Section 18 of the General Terms and Conditions of the Agreement shall be construed to prevent either Party from disclosing the other Party's information to the Arbitrator in connection with or in anticipation of an arbitration proceeding. In addition, the Arbitrators may issue orders to protect the confidentiality of proprietary information, trade secrets, or other sensitive information.
- 14.2 In order to maintain the privacy of all arbitration conferences and hearings, the Arbitrators shall have the power to require the exclusion of any person other than a Party, counsel thereto, or other essential persons.
- enforcement of an award, or unless otherwise required by an order of award process of a court or governmental body.

TABLE OF CONTENTS

1. INTRODUCTION .....	2
2. LOOP COMBINATION .....	2
3. INTEGRATED DIGITAL LOOP CARRIERS .....	5
4. LOOP DISTRIBUTION .....	5
5. LOOP CONCENTRATOR/MULTIPLEXER .....	11
6. LOOP FEEDER .....	15
7. LOCAL SWITCHING .....	19
8. OPERATOR SYSTEMS .....	29
9. COMMON TRANSPORT .....	32
10. DEDICATED TRANSPORT .....	36
11. SIGNALING LINK TRANSPORT .....	50
12. SIGNALING TRANSFER POINTS (STPS) .....	51
13. SERVICE CONTROL POINTS/DATABASES .....	58
14. TANDEM SWITCHING .....	70
15. DARK FIBER .....	72
16. ADDITIONAL REQUIREMENTS .....	73

## SERVICE DESCRIPTION: UNBUNDLED NETWORK ELEMENTS

### Introduction

This Attachment sets forth the descriptions and requirements for unbundled network elements that BellSouth agrees to offer to AT&T under this Agreement.

## 2. Loop Combination

### 2.1 **Definition**

2.1.1 The Loop or Loop Combination is a combination of the network interface device (NID), loop distribution and loop feeder, with or without a loop concentrator/multiplexer. The loop is the physical medium or functional path on which a subscriber's traffic (multiplexed or non-multiplexed, concentrated or non-concentrated) is carried from the MDF, DSX, LGX or DCS in a central office or similar environment (including remote switching modules) up to the termination at the NID at the customer's premise.

2.1.2 The provisioning of service to a customer will require cross-office cabling and cross-connections within the central office to connect the loop to a local switch or to other transmission equipment in co-located space. These cables and cross-connections may be considered part of the loop, the switch or other transmission equipment, or as a separately tarified element.

### 2.2 **Technical Requirements**

2.2.1 The Loop or Loop Combination shall be capable of performing transmission and signaling functions associated with all local services including the following (whenever needed by AT&T and wherever available in the BellSouth network, to provide end-to-end service capability to AT&T's customer):

2.2.1.1 2-wire voice grade basic telephone services;

2.2.1.2 2-wire ISDN;

2.2.1.3 2-wire CENTREX;

2.2.1.4 2 and 4-wire PBX lines or trunks;

2.2.1.5 2 and 4-wire voice grade private lines and foreign exchange lines;

- 2.2.1.6 4-wire digital data (2.4Kbps through 64Kbps and n times 64Kbps, where  $n \leq 24$ );
- 2.2.1.7 4-wire DS1 (switched or private line);
- 2.2.1.8 DS-3 rate private lines; and
- 2.2.1.9 Optical SONET OC-n rate private lines.
- 2.2.2 The alternatives for the unbundled loop combination include but are not limited to:
  - 2.2.2.1 Copper twisted pair loop from the NID at the customer's premise to the MDF in the LEC local serving office (LSO).
  - 2.2.2.2 Copper twisted pair distribution from the NID at the customer's premise to a loop concentrator/multiplexer located external to the LSO, with metallic T1 or fiber feeder from the concentrator/multiplexer to an MDF or DSX frame in the LSO (see loop concentrator/multiplexer section for possible variations).
  - 2.2.2.3 Whenever available in the BellSouth network, BellSouth will provide Hybrid fiber coax loop that consists of coax cable from an NID/NIU at the customer's premise to a fiber node, fiber cable from the fiber node to a Host Digital Terminal (HDT) in the LSO, and DS1s from the HDT to a DSX frame in the LSO.
  - 2.2.2.4 DS1 rate loop over a metallic T1 or optical SONET/asynchronous network facility from the NID at the customer's premise to a DSX frame in the LEC LSO.
  - 2.2.2.5 DS3 rate loop over optical SONET/asynchronous network facility from the NID at the customer's premise to a DSX frame or DCS in the LEC LSO.
  - 2.2.2.6 SONET OC-n rate loop from the NID at the customer's premise to a Lightguide Cross-connect (LGX) or DCS in the LSO.
  - 2.2.2.7 Services supported by the loop combinations will include POTS, CENTREX, basic rate ISDN, analog PBX, voice grade private line, and digital data (up to 64 Kb/s). Additional services may include digital PBXs, primary rate ISDN, Nx 64Kb/s, and DS1/DS3 and SONET private lines.
  - 2.2.2.8 The loop combination must support the transmission, signaling, performance and interface requirements of the services to be provided

over it. It is recognized that the requirements of different services are different, and that a number of types or grades of loops are required to support these services. Services provided over the loop by AT&T will be consistent with industry standards.

- 2.2.2.9 In some instances, AT&T will require access to copper twisted pair loop combination unfettered by any intervening equipment (e.g. filters, load coils, range extenders, etc.), so that AT&T can use the loop combination for a variety of services by attaching appropriate terminal equipment at the ends. AT&T will determine the type of service that will be provided over the loop combination.
- 2.2.3 The Loop Combination shall be provided to AT&T in accordance with the following Technical References:
  - 2.2.3.1 Bellcore TR-NWT-000057, Functional Criteria for Digital Loop Carrier Systems, Issue 2, January 1993.
  - 2.2.3.2 Bellcore TR-NWT-000393, Generic Requirements for ISDN Basic Access Digital Subscriber Lines.
  - 2.2.3.3 ANSI T1.106 - 1988, American National Standard for Telecommunications - Digital Hierarchy - Optical Interface Specifications (Single Mode).
  - 2.2.3.4 ANSI T1.105 - 1995, American National Standard for Telecommunications - Synchronous Optical Network (SONET) - Basic Description including Multiplex Structure, Rates and Formats.
  - 2.2.3.5 ANSI T1.102 - 1993, American National Standard for Telecommunications - Digital Hierarchy - Electrical Interfaces.
  - 2.2.3.6 ANSI T1.403 - 1989, American National Standard for Telecommunications - Carrier to Customer Installation, DS1 Metallic Interface Specification.
  - 2.2.3.7 Bellcore GR-253-CORE, Synchronous Optical Network Systems (SONET), Common Generic Criteria.
  - 2.2.3.8 DELETED
  - 2.2.3.9 DELETED
  - 2.2.3.10 DELETED
  - 2.2.3.11 DELETED

- 2.2.3.12 DELETED
- 2.2.3.13 Bellcore TR-TSY-000008, Digital Interface Between the SLC 96 Digital Loop Carrier System and a Local Digital Switch, Issue 2, August 1987
- 2.2.3.14 Bellcore TR-NWT-000303, Integrated Digital Loop Carrier System Generic Requirements, Objectives and Interface, Issue 2, December 1992; Rev.1, December 1993; Supplement 1, December 1993
- 2.2.3.15 Bellcore TR-TSY-000673, Operations Systems Interface for an IDLC System, (LSSGR) FSD 20-02-2100, Issue 1, September 1989
- 2.2.3.16 DELETED
- 2.2.3.17 DELETED
- 2.2.3.18 DELETED
- 2.2.3.19 DELETED

3. **Integrated Digital Loop Carriers**

Where BellSouth uses integrated Digital Loop Carrier (DLCs) systems to provide the local loop, BellSouth will make alternative arrangements to permit AT&T to order a contiguous unbundled local loop. These arrangements must provide AT&T with the capability to serve all of BellSouth's Customers at the same level BellSouth provides itself.

4. **Loop Distribution**

Loop Distribution is composed of two distinct component parts: a Network Interface Device and Distribution Media. Each component part is defined in detail below.

4.1 **Network Interface Device**

4.1.1 **Definition**

4.1.1.1 **The Network Interface Device (NID) is a single-line termination device or that portion of a multiple-line termination device required to terminate a single line or circuit. The fundamental function of the NID is to establish the official network demarcation point between a carrier and its end-user customer. The NID features two independent chambers or divisions which separate the service provider's network from the customer's inside wiring. Each chamber or division contains the appropriate connection points or posts to which the service provider, and the end-user customer**

each make their connections. The NID provides a protective ground connection, and is capable of terminating cables such as twisted pair cable.

- 4.1.1.1 BellSouth shall allow AT&T to access the customer's inside wiring. Such access may take place through either of the following: 1) allow AT&T to use any existing capacity on BellSouth's NID; or 2) in instances where spare capacity does not exist, AT&T may connect its NID to BellSouth's NID only in adherence with the FCC rules regarding a NID to NID arrangement, until such time as appropriate guidelines for connection to the NID are developed and incorporated within the National Electric Safety Code.
- 4.1.1.2 With respect to multiple-line termination devices, AT&T shall specify the quantity of NIDs it requires within such device.
- 4.1.1.3 Figure 1 shows a schematic of a NID.

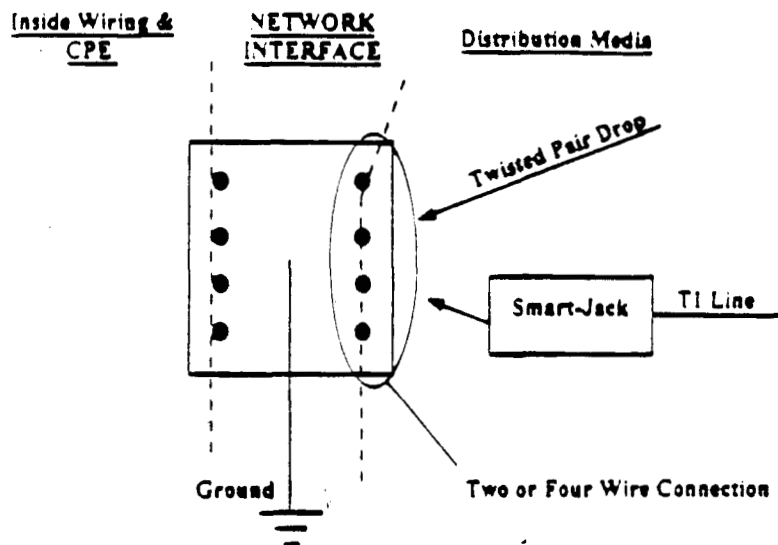

Figure 1 - Network Interface Device

- 4.1.2 **Technical Requirements**
- 4.1.2.1 The Network Interface Device shall provide a clean, accessible point of connection for the inside wiring and for the Distribution Media and shall maintain a connection to ground that means the requirements set forth below.



- 4.1.2.2 The NID shall be capable of transferring electrical analog or digital signals between the customer's inside wiring and the Distribution Media.
- 4.1.2.3 All NID posts or connecting points shall be in place, secure, usable and free of any rust or corrosion. The protective ground connection shall exist and be properly installed. The ground wire will also be free of rust or corrosion and have continuity relative to ground.
- 4.1.2.4 The NID shall be capable of withstanding all normal local environmental variations.
- 4.1.2.5 Where the NID is not located in a larger, secure cabinet or closet, the NID shall be protected from physical vandalism. The NID shall be physically accessible to AT&T designated personnel. In cases where entrance to the customer premises is required to give access to the NID, AT&T shall obtain entrance permission directly from the customer.
- 4.1.2.6 BellSouth shall offer the NID together with, and separately from the Distribution Media component of Loop Distribution.
- 4.1.3 **Interface Requirements**
  - 4.1.3.1 The NID shall be the interface to customers' premises wiring for alternative loop technologies.
  - 4.1.3.2 BellSouth shall permit AT&T to remove any existing terminations to the NID and replace them with terminations designated by AT&T. BellSouth shall not remove or alter customer inside wiring.
  - 4.1.3.3 The NID shall be equal to or better than all of the requirements for NIDs set forth in the following technical references:
    - 4.1.3.3.1 Bellcore Technical Advisory TA-TSY-000120 "Customer Premises or Network Ground Wire";
    - 4.1.3.3.2 Bellcore Generic Requirement GR-49-CORE "Generic Requirements for Outdoor Telephone Network Interface Devices";
    - 4.1.3.3.3 Bellcore Technical Requirement TR-NWT-00239 "Indoor Telephone Network Interfaces";
    - 4.1.3.3.4 Bellcore Technical Requirement TR-NWT-000937 "Generic Requirements for Outdoor and Indoor Building Entrance"; and
    - 4.1.3.3.5 Bellcore Technical Requirement TR-NWT-000133 "Generic Requirements for Network Inside Wiring."

*UB*

- 4.2 **Distribution Media**
- Any request by AT&T for unbundling of Distribution Media will be made pursuant to the Bona Fide Request Process identified in Section 1.1 of the General Terms and Conditions.
- 4.2.1 **Definition**
- 4.2.1.1 Distribution Media provides connectivity between the NID component of Loop Distribution and the terminal block on the customer-side of a Feeder Distribution Interface (FDI). The FDI is a device that terminates the Distribution Media and the Loop Feeder, and cross-connects them in order to provide a continuous transmission path between the NID and a telephone company central office. For loop plant that contains a Loop Concentrator/Multiplexer, the Distribution Media may terminate at the FDI (if one exists), or at a termination and cross-connect field associated with the Loop Concentrator/Multiplexer. This termination and cross-connect field may be in the form of an outside plant distribution closure, remote terminal or fiber node, or an underground vault.
- 4.2.1.2 The Distribution Media may be copper twisted pair, coax cable, or single or multi-mode fiber optic cable. A combination that includes two or more of these media is also possible. In certain cases, AT&T shall require a copper twisted pair Distribution Media even in instances where the Distribution Media for services that BellSouth offers is other than a copper facility.
- 4.2.2 **Requirements for All Distribution Media**
- 4.2.2.1 Distribution Media shall be capable of transmitting signals for the following services (as needed by AT&T to provide end-to-end service capability to its customer):
- 4.2.2.1.1 2-wire voice grade basic telephone services;
  - 4.2.2.1.2 2-wire ISDN;
  - 4.2.2.1.3 2-wire CENTREX;
  - 4.2.2.1.4 2 and 4-wire PBX lines or trunks;
  - 4.2.2.1.5 2 and 4-wire voice grade private lines and foreign exchange lines;
  - 4.2.2.1.6 4-wire digital data (2.4Kbps through 64Kbps and n times 64Kbps (where  $n \leq 24$ ); and
  - 4.2.2.1.7 4-wire DS1 (switched or private line).

- 4.2.2.2 Distribution Media shall transmit all signaling messages or tones. Where the Distribution Media includes any active elements that terminate any of the signaling messages or tones, these messages or tones shall be reproduced by the Distribution Media at the interfaces to an adjacent Network Element in a format that maintains the integrity of the signaling messages or tones.
- 4.2.2.3 Distribution Media shall support functions associated with provisioning, maintenance and testing of the Distribution Media itself, as well as provide necessary access to provisioning, maintenance and testing functions for Network Elements to which it is associated.
- 4.2.2.4 Distribution Media shall provide performance monitoring of the Distribution Media itself, as well as provide necessary access for performance monitoring for Network Elements to which it is associated.
- 4.2.2.5 Distribution Media shall be equal to or better than all of the applicable requirements set forth in the following technical references:
- 4.2.2.5.1 Bellcore TR-TSY-000057, "Functional Criteria for Digital Loop Carrier Systems"; and
- 4.2.2.5.2 Bellcore TR-NWT-000393, "Generic Requirements for ISDN Basic Access Digital Subscriber Lines."
- 4.2.2.6 BellSouth shall provide AT&T with physical access to, and the right to connect to, the FDI.
- 4.2.2.6.1 BellSouth shall offer Distribution Media together with, and separately from the NID component of Loop Distribution.
- 4.2.3 **Additional Requirements for Special Copper Distribution Media**  
In addition to Distribution Media that supports the requirements in Section 4.2.2 (above), AT&T may designate Distribution Media to be copper twisted pair which are unfettered by any intervening equipment (e.g., filters, load coils, range extenders) so that AT&T can use these loops for a variety of services by attaching appropriate terminal equipment at the ends.
- 4.2.4 **Additional Requirements for Fiber Distribution Media**  
Fiber optic cable Distribution Media shall be capable of transmitting signals for the following services in addition to the ones under Section 4.2.2.1 above:
- 4.2.4.1 DS3 rate private line service;

UB

FL6/10/97

4 2 4 2	Optical SONET OC-n rate private lines where n is defined in the technical reference in Section 5 2 4 of this Attachment 2, and
4 2 4 3	Analog Radio Frequency based services (e.g. Cable Television, CATV)
4 2 5	Additional Requirements for Coaxial Cable Distribution Media
	Coaxial cable (coax) Distribution Media shall be capable of transmitting signals for the following services in addition to the ones under Section 4 2 2 1 above:
4 2 5 1	Broadband data, either one way or bi-directional, symmetric or asymmetric, at rates between 1.5 Mb/s and 45 Mb/s; and
4 2 5 2	Analog Radio Frequency based services (e.g. CATV)
4 2 6	<b>Interface Requirements</b>
4 2 6 1	Signal transfers between the Distribution Media and the NID and an adjacent Network Element shall have levels of degradation that are within the performance requirements set forth in Section 16 2 of this Attachment 2.
4 2 6 2	Distribution Media shall be equal to or better than each of the applicable interface requirements set forth in the following technical references:
4 2 6 2 1	Bellcore TR-NWT-000049, "Generic Requirements for Outdoor Telephone Network Interface Devices," issued December 1, 1994;
4 2 6 2 2	Bellcore TR-NWT-000057, "Functional Criteria for Digital Loop Carrier Systems," issued January 2, 1993;
4 2 6 2 3	Bellcore TR-NWT-000393, "Generic Requirements for ISDN Basic Access Digital Subscriber Lines";
4 2 6 2 4	Bellcore TR-NWT-000253, SONET Transport Systems: Common Criteria (A module of TSGR, FR-NWT-000440), Issue 2, December 1991;
4 2 6 2 5	AT&T Data Communications Technical Reference TR 62310, DS0 Digital Local Channel Description and Interface Specification, August 1993; Also Addendum 1 and Addendum 2;
4 2 6 2 6	AT&T Technical Reference TR 62411, ACCUNET T1.5 Service Description and Interface Specification, December 1990; Addendum 1, March 1991; Addendum 2, October 1992; and

4.2.6.2.7 AT&T Technical Reference TR 62421 ACCUNET Spectrum of Digital Services Description and Interface Specification, December 1989. Also TR 62421A Addendum 2, November 1992.

5 **Loop Concentrator/Multiplexer**

Any request by AT&T for unbundling the Loop Concentrator/Multiplexer will be made pursuant to the Bona Fide Request Process identified in Section 1.1. of the General Terms and Conditions.

5.1 **Definition**

5.1.1 The Loop Concentrator/Multiplexer is the Network Element that: (1) aggregates lower bit rate or bandwidth signals to higher bit rate or bandwidth signals (multiplexing); (2) disaggregates higher bit rate or bandwidth signals to lower bit rate or bandwidth signals (demultiplexing); (3) aggregates a specified number of signals or channels to fewer channels (concentrating); (4) performs signal conversion, including encoding of signals (e.g., analog to digital and digital to analog signal conversion); and (5) in some instances performs electrical to optical (E/O) conversion.

5.1.2 The Loop Concentrator/Multiplexer function may be provided through a Digital Loop Carrier (DLC) system, channel bank, multiplexer or other equipment at which traffic is encoded and decoded, multiplexed and demultiplexed, or concentrated. In cases where this Network Element is required on an integrated DLC, BellSouth will provide it by a universal DLC alternative.

5.2 **Technical Requirements**

5.2.1 The Loop Concentrator/Multiplexer shall be capable of performing its functions on the signals for the following services, including but not limited to, (as needed by AT&T to provide end-to-end service capability to its customer):

5.2.1.1 2-wire voice grade basic telephone services;

5.2.1.2 2-wire ISDN;

5.2.1.3 2-wire CENTREX;

5.2.1.4 2 and 4-wire PBX lines or trunks;

5.2.1.5 2 and 4-wire voice grade private lines and foreign exchange lines;

- 5.2.1.6 4-wire digital data (2.4Kbps through 64Kbps and n times 64Kbps where  $n \leq 24$ ).
- 5.2.1.7 4-wire DS1 (switched or private line);
- 5.2.1.8 DS-3 rate private lines;
- 5.2.1.9 Optical SONET rate private lines; and
- 5.2.1.10 Coin services
- 5.2.2 The Loop Concentrator/Multiplexer shall perform the following functions as appropriate:
  - 5.2.2.1 Analog to digital signal conversion of both incoming and outgoing (upstream and downstream) analog signals;
  - 5.2.2.2 Multiplexing of the individual digital signals up to higher transmission bit rate signals (e.g., DSO, DS1, DS3, or optical SONET rates) for transport to BellSouth central office through the Loop Feeder; and
  - 5.2.2.3 Concentration of end-user customer signals onto fewer channels of a Loop Feeder. (The concentration ratio provided for the Network Elements requested by AT&T shall be no higher than the Loop Concentrator/Multiplexer concentration ratio BellSouth uses to provide service to its own customers.)
- 5.2.3 BellSouth shall provide power for the Loop Concentrator/ Multiplexer, through a non-interruptible source if the function is performed in a central office, or from a commercial AC power source with battery backup if the equipment is located outside a central office. Such power shall also adhere to the requirements stated in the Section 2 of Attachment 3.
- 5.2.4 The Loop Concentrator/Multiplexer shall be provided to AT&T in accordance with the following Technical References:
  - 5.2.4.1 Bellcore TR-NWT-000057, Functional Criteria for Digital Loop Carrier Systems, Issue 2, January 1993.
  - 5.2.4.2 Bellcore TR-NWT-000393, Generic Requirements for ISDN Basic Access Digital Subscriber Lines.
  - 5.2.4.3 ANSI T1.106 - 1988, American National Standard for Telecommunications - Digital Hierarchy - Optical Interface Specifications (Single Mode).

- 5.2.4.4 ANSI T1.105 - 1995, American National Standard for Telecommunications - Synchronous Optical Network (SONET) - Basic Description including Multiplex Structure, Rates and Formats
- 5.2.4.5 ANSI T1.102 - 1993, American National Standard for Telecommunications - Digital Hierarchy - Electrical Interfaces
- 5.2.4.6 ANSI T1.403- 1989, American National Standard for Telecommunications - Carrier to Customer Installation, DS1 Metallic Interface Specification.
- 5.2.4.7 Bellcore GR-253-CORE, Synchronous Optical Network Systems (SONET), Common Generic Criteria.
- 5.2.4.8 AT&T Data Communications Technical Reference TR 62310, DS0 Digital Local Channel Description and Interface Specification, August 1993; Also Addendum 1 and Addendum 2.
- 5.2.4.9 AT&T Technical Reference TR 62411, ACCUNET T1.5 Service Description and Interface Specification, December 1990; Addendum 1, March 1991; Addendum 2, October 1992.
- 5.2.4.10 AT&T Technical Reference TR 62421, ACCUNET Spectrum of Digital Services Description and Interface Specification, December 1989; Also TR 62421A Addendum 2, November 1992.
- 5.2.4.11 AT&T Technical Reference TR 54014, ACCUNET T45 Reserved Services - Service Description and Interface Specification.
- 5.2.4.12 AT&T Technical Reference TR 54018, ACCUNET T155 Service Description and Interface Specification.
- 5.2.4.13 Bellcore TR-TSY-000008, Digital Interface Between the SLC 96 Digital Loop Carrier System and a Local Digital Switch, Issue 2, August 1987.
- 5.2.4.14 Bellcore TR-NWT-000303, Integrated Digital Loop Carrier System Generic Requirements, Objectives and Interface, Issue 2, December 1992; Rev.1, December 1993; Supplement 1, December 1993.
- 5.2.4.15 Bellcore TR-TSY-000673, Operations Systems Interface for an IDLC System, (LSSGR) FSD 20-02-2100, Issue 1, September 1989.
- 5.2.4.16 AT&T Technical Reference TR 62411, ACCUNET T1.5 Service Description and Interface Specification, December 1990; Addendum 1, March 1991; Addendum 2, October 1992.

- 5.2.4.17 AT&T Technical Reference TR 62421 ACCUNET Spectrum of Digital Services Description and Interface Specification December 1989 Also TR 62421A Addendum 2, November 1992.
- 5.2.4.18 AT&T Technical Reference TR 54014 ACCUNET T45 Reserved Services - Service Description and Interface Specification
- 5.2.4.19 AT&T Technical Reference TR 54018, ACCUNET T155 Service Description and Interface Specification.
- 5.3 **Requirements for an Intelligent Loop Concentrator/Multiplexer**
- 5.3.1 In addition to the basic functions described above for the Loop Concentrator/Multiplexer, the Intelligent Loop Concentrator/Multiplexer (IC/M) shall provide facility grooming, facility test functions, format conversion and signaling conversion as appropriate.
- 5.3.2 At AT&T's option, BellSouth shall provide immediate and continuous configuration and reconfiguration of the channels within the physical interfaces (i.e., of cross connects, as well as direct AT&T control of such configurations and reconfigurations) on the underlying device that provides such IC/M function.
- 5.3.3 At AT&T's option, BellSouth shall provide scheduled configuration and reconfiguration of the channels within the physical interfaces (i.e., of cross connects, as well as direct AT&T control of such configurations and reconfigurations) on the underlying device that provides such IC/M function.
- 5.3.4 The underlying equipment that provides such IC/M function shall continuously monitor protected circuit packs and redundant common equipment.
- 5.3.5 The underlying equipment that provides such IC/M function shall automatically switch to a protection circuit pack on detection of a failure or degradation of normal operation.
- 5.3.6 The underlying equipment that provides such IC/M function shall be equipped with a redundant power supply or a battery back-up.
- 5.3.7 At AT&T's option, BellSouth shall provide AT&T with real time performance monitoring and alarm data on IC/M elements that may affect AT&T's traffic. This includes IC/M hardware alarm data and facility alarm data on the underlying device that provides such IC/M function.

*UB*



- 5.3.8 At AT&T's option, BellSouth shall provide AT&T with real-time ability to initiate tests on the underlying device that provides such IC/M function. Integrated test equipment as well as other integrated functionality for routine testing and fault isolation.
- 5.3.9 The IC/M shall be capable of performing signaling conversion and data conditioning in compliance with AT&T Technical Reference TR 62421 ACCUNET<sup>®</sup> Spectrum of Digital Services, December 1989 and AT&T Technical Reference TR 62310 DS0 Digital Local Channel Description and Interface Specification, August 1993, including current addendums.
- 5.4 **Interface Requirements**
- The Loop Concentrator/Multiplexer shall meet the following interface requirements, as appropriate for the configuration that AT&T designates.
- 5.4.1 The Loop Concentrator/Multiplexer shall provide an analog voice frequency copper twisted pair interface to the local switch (e.g., universal DLC applications), as described in the references in Section 5.2.4 of this Attachment.
- 5.4.2 The Loop Concentrator/Multiplexer shall provide digital 4-wire electrical interfaces to the local digital switch, as described in the references in Section 5.2.4 of this Attachment.
- 5.4.3 The Loop Concentrator/Multiplexer shall provide optical SONET interfaces at rates of OC-N as described in the references in Section 5.2.4 of this Attachment.
- 5.4.4 The Loop Concentrator/Multiplexer shall provide the Bellcore TR-303 DS1 level interface to a Local Digital switch. Loop Concentrator/Multiplexer shall provide Bellcore TR-08 modes 1&2 DS1 interfaces when designated by AT&T. Such interface requirements are specified in the references in Section 5.2.4 of this Attachment.
- 5.4.5 The Loop Concentrator/Multiplexer shall provide Integrated Network Access (INA) DS1s for non-locally switched or non-switched special services, as described in the references in Section 5.2.4 of this Attachment.
- 5.5 The Intelligent Loop Concentrator/Multiplexer shall be provided to AT&T in accordance with the Technical References set forth in Sections 5.2.4.13 through 5.2.4.19 above.

6. **Loop Feeder**

UB

FL6/10/97

Any request by AT&T for unbundling the Loop Feeder will be made pursuant to the Bona Fide Request Process identified in Section 1.1 of the General Terms and Conditions of this Agreement.

6.1 **Definition**

6.1.1 The Loop Feeder is the Network Element that provides connectivity between (1) a FDI associated with Loop Distribution and a termination point appropriate for the media in a central office, or (2) a Loop Concentrator/Multiplexer provided in a remote terminal and a termination point appropriate for the media in a central office. BellSouth shall provide the necessary cabling between the BellSouth equipment (i.e. FDI) and AT&T's equipment.

6.1.2 The physical medium of the Loop Feeder may be copper twisted pair, or single or multi-mode fiber as designated by AT&T and where available in the BellSouth network. In certain cases, BellSouth must provide a copper twisted pair loop even in instances where the medium of the Loop Feeder for services that BellSouth offers is other than a copper facility.

6.2 **Requirements for All Loop Feeder Media**

6.2.1 The Loop Feeder shall be capable of transmitting analog voice frequency, basic rate ISDN, digital data, or analog radio frequency signals, where available in the BellSouth network.

6.2.2 BellSouth shall provide appropriate power for all active elements in the Loop Feeder. BellSouth will provide appropriate power from a central office source, or from a commercial AC source with rectifiers for AC to DC conversion and 8-hour battery back-up when the equipment is located in an outside plant Remote Terminal (RT).

6.3 **Additional Requirements for Special Copper Loop Feeder Medium**

In addition to requirements set forth in Section 6.2 above, and where available in the BellSouth network, AT&T may require BellSouth to provide copper twisted pair Loop Feeder which are unfettered by any intervening equipment (e.g. filters, load coils, and range extenders), so that AT&T can use these Loop Feeders for a variety of services by attaching appropriate terminal equipment at the ends.

6.4 **Additional Technical Requirements for DS1 Conditioned Loop Feeder**

In addition to the requirements set forth in Section 6.2 above, and where available in the BellSouth network, AT&T may designate that the Loop

Feeder be conditioned to transport a DS1 signal. The requirements for such transport are defined in the references below in Section 6.6.

- 6.5 **Additional Technical Requirements for Optical Loop Feeder**  
In addition to the requirements set forth in Section 6.2 above, and where available in the BellSouth network, AT&T may designate that Loop Feeder will transport DS3 and OCn (where n is defined in the technical reference in Section 5.2.4.4). The requirements for such transport are defined in the references below in Section 6.6.
- 6.6 BellSouth shall offer Loop Feeder in accordance with the requirements set forth in the following Technical References:
- 6.6.1 **DELETED**
- 6.6.2 Bellcore Technical Requirement TR-NWT-000499, Issue 5, December 1993, section 7 for DS1 interfaces;
- 6.6.3 **DELETED**
- 6.6.4 Bellcore TR-NWT-000057, Functional Criteria for Digital Loop Carrier Systems, Issue 2, January 1993.
- 6.6.5 Bellcore TR-NWT-000393, Generic Requirements for ISDN Basic Access Digital Subscriber Lines.
- 6.6.6 ANSI T1.106 - 1988, American National Standard for Telecommunications - Digital Hierarchy - Optical Interface Specifications (Single Mode).
- 6.6.7 ANSI T1.105 - 1995, American National Standard for Telecommunications - Synchronous Optical Network (SONET) - Basic Description including Multiplex Structure, Rates and Formats.
- 6.6.8 ANSI T1.102 - 1993, American National Standard for Telecommunications - Digital Hierarchy - Electrical Interfaces.
- 6.6.9 ANSI T1.403- 1989, American National Standard for Telecommunications - Carrier to Customer Installation, DS1 Metallic Interface Specification.
- 6.6.10 Bellcore GR-253-CORE, Synchronous Optical Network Systems (SONET), Common Generic Criteria.
- 6.6.11 **DELETED**

*UB*

- 6.6.12 DELETED
- 6.6.13 DELETED
- 6.6.14 DELETED
- 6.7 **Interface Requirements**
- 6.7.1 The Loop Feeder point of termination (POT) within a BellSouth central office will be as follows:
  - 6.7.1.1 Copper twisted pairs shall terminate on the MDF;
  - 6.7.1.2 DS1 Loop Feeder shall terminate on a DSX1, DCS1/0 or DCS3/1 and
  - 6.7.1.3 Fiber Optic cable shall terminate on a LGX.
- 6.7.2 When requested by AT&T:
  - The Loop Feeder shall provide the analog voice frequency copper twisted pair interface for switched or private line services, as defined in the references in Section 6.6 of this Attachment.
  - 6.7.2.1 Where available in the BellSouth network, the Loop Feeder shall provide the ISDN basic rate interface, as defined in the references in Section 6.6, to the local digital switch designated by AT&T.
  - 6.7.2.2 The Loop Feeder shall provide digital 4-wire electrical interfaces for digital data services, as defined in the references in Section 6.6 of this Attachment.
  - 6.7.2.3 The Loop Feeder shall provide the standard electrical DS1 interface for applications utilizing DS1 feeder, as defined in the references in Section 6.6 of this Attachment.
  - 6.7.2.4 Where available in the BellSouth network, the Loop Feeder shall provide optical SONET interfaces at the OC-N rates as defined in the references in Section 6.6 of this Attachment.
- 6.7.3 Loop Feeder shall be equal to or better than each of the applicable interface requirements set forth in the following technical references:
  - 6.7.3.1 Bellcore TR-TSY-000008, Digital Interface Between the SLC 96 Digital Loop Carrier System and a Local Digital Switch, Issue 2, August 1987
  - 6.7.3.2 Bellcore TR-NWT-000303, Integrated Digital Loop Carrier System Generic Requirements, Objectives and Interface, Issue 2, December 1992; Rev.1, December 1993; Supplement 1, December 1993.

  
FL6/10/97

6.7.3.3 DELETED

6.7.3.4 DELETED

6.7.3.5 DELETED

6.7.3.6 DELETED

7 Local Switching

7.1 Definition

7.1.1 Local Switching is the Network Element that provides the functionality required to connect the appropriate originating lines or trunks wired to the Main Distributing Frame (MDF) or Digital Cross Connect (DSX) panel to a desired terminating line or trunk. Such functionality shall include all of the features, functions, and capabilities that the underlying BellSouth switch that is providing such Local Switching function is then capable of providing, including but not limited to: line signaling and signaling software; digit reception, dialed number translations, call screening, routing, recording, call supervision, dial tone, switching, telephone number provisioning, announcements, calling features and capabilities (including call processing), CENTREX, Automatic Call Distributor (ACD), Carrier pre-subscription (e.g. long distance carrier, intraLATA toll), Carrier Identification Code (CIC) portability capabilities, testing and other operational features inherent to the switch and switch software. It also provides access to transport, signaling (ISDN User Part (ISUP) and Transaction Capabilities Application Part (TCAP), and platforms such as adjuncts, Public Safety Systems (911), operator services, Directory Assistance Services and Advanced Intelligent Network (AIN). Remote Switching Module functionality is included in the Local Switching function. The switching capabilities used will be based on the line side features they support. Local Switching will also be capable of routing local, intraLATA, interLATA, and calls to international customer's preferred carrier; call features (e.g., call forwarding) and CENTREX capabilities. Local Switching, including the ability to route to AT&T's transport facilities, dedicated facilities and systems, shall be unbundled from all other unbundled Network Elements, i.e., Operator Systems, Common Transport, and Dedicated Transport. In addition, BellSouth agrees to work with AT&T and other ALECs on a routing resource conversation program and file a capacity expansion program to relieve routing resource constraints for 95% of the market. BellSouth and AT&T shall continue to work with the appropriate industry groups to develop a long-term solution for selective routing. BellSouth may reserve for itself

an appropriate and reasonable number of line class codes for its own use.

- 7.1.2 Local Switching also includes Data Switching, which provides
- 7.1.2.1 For Frame Relay Service, data services switching functionality that is required to connect the facilities from the User to Network Interface (UNI) to either another UNI or to a communications path at the Network to Network Interface (NNI). In this case, the purpose of Data Switching is to terminate, concentrate, and switch data traffic from Customer Premises Equipment (CPE) in the digital format consistent with the UNI specification for the customer. Data Switching also provides connectivity for the purpose of conveying the customer data to its final destination. The UNI and NNI are industry standard interface specifications that contain physical transmission layer requirements for speeds and line formats; data link layer requirements for the format of the data units that are passed between the user and the network; and protocol requirements for control procedures used in managing the interface.
- 7.1.2.2 For ISDN Packet and Circuit Switched Data service, the data switching functionality that is required to connect between industry standard ISDN interfaces. In this case, the purpose of Data Switching is to terminate, concentrate, and switch data traffic from Customer Premises Equipment (CPE) in the digital format consistent with ISDN standards. Data Switching also provides connectivity for the purpose of conveying the customer data to its final destination.
- 7.2 The requirements set forth in this Section 7.2 apply to Local Switching, but not to the Data Switching function of Local Switching.
- 7.2.1 **Technical Requirements**
- 7.2.1.1 Local Switching shall be equal to or better than the requirements for Local Switching set forth in Bellcore's Local Switching Systems General Requirements (FR-NWT-000064).
- 7.2.1.2 When applicable, BellSouth shall route calls to the appropriate trunk or lines for call origination or termination.
- 7.2.1.3 BellSouth's local switch shall maintain translations necessary to direct AIN queries for selected lines and dialing sequences to the AT&T SS7 network.

gmr

- 7.2.1.4 BellSouth's local switch shall accept mutually agreeable AIN responses from the AT&T SCP via SS7 network interconnection then continue call handling according to instructions contained in the response.
- 7.2.1.5 BellSouth shall route calls on a per line or per screening class basis to (1) BellSouth platforms providing Network Elements or additional requirements (2) Operator Services platforms, (3) Directory Assistance platforms, and (4) Repair Centers. Any other routing requests by AT&T will be made pursuant to the Bona Fide Request Process identified in Section 1.1 of this Agreement.
- 7.2.1.6 BellSouth shall provide unbranded recorded announcements and call progress tones to alert callers of call progress and disposition.
- 7.2.1.7 BellSouth shall activate service for an AT&T customer or network interconnection on any of the Local Switching interfaces. This includes provisioning changes to change a customer from BellSouth's services to AT&T's services without loss of switch feature functionality as defined in this Agreement.
- 7.2.1.8 BellSouth shall perform routine testing (e.g., Mechanized Loop Tests (MLT) and test calls such as 105, 107 and 108 type calls) and fault isolation on a mutually agreed upon schedule.
- 7.2.1.9 BellSouth shall repair and restore any equipment or any other maintainable component that may adversely impact Local Switching.
- 7.2.1.10 BellSouth shall control congestion points such as those caused by radio station call-ins, and network routing abnormalities. All traffic shall be restricted in a non discriminatory manner.
- 7.2.1.11 BellSouth shall perform manual call trace and permit customer originated call trace.
- 7.2.1.12 **DELETED**
- 7.2.1.13 For Local Switching used as 911 Tandems, BellSouth shall allow interconnection from AT&T local switching elements and BellSouth shall route the calls to the appropriate Public Safety Access Point (PSAP).
- 7.2.1.14 Special Services provided by BellSouth will include the following:  
Essential Service Lines;  
Telephone Service Prioritization;  
Related services for handicapped;
- 7.2.1.14.1
- 7.2.1.14.2
- 7.2.1.14.3

- 7.2.1.14.4 Soft dial tone where required by law and
- 7.2.1.14.5 Any other service required by law
- 7.2.1.15 BellSouth shall provide Switching Service Point (SSP) capabilities and signaling software to interconnect the signaling links destined to the Signaling Transfer Point Switch (STPS). These capabilities shall adhere to Bellcore specifications - TCAP (GR-1432-CORE), ISUP (GR-905-CORE), Call Management (GR-1429-CORE), Switched Fractional DS1 (GR-1357-CORE), Toll Free Service (GR-1428-CORE), Calling Name (GR-1597-CORE), Line Information Database (GR-954-CORE), and Advanced Intelligent Network (GR-2863-CORE).
- 7.2.1.16 BellSouth shall provide interfaces to adjuncts through Bellcore standard interfaces. These adjuncts can include, but are not limited to, the Service Circuit Node and Automatic Call Distributors.
- 7.2.1.17 BellSouth shall provide performance data regarding a customer line, traffic characteristics or other measurable elements to AT&T, upon a reasonable request from AT&T.
- 7.2.1.18 BellSouth shall offer Local Switching that provides feature offerings at parity to those provided by BellSouth to itself or any other party. Such feature offerings shall include but are not limited to:
  - 7.2.1.18.1 Basic and primary rate ISDN;
  - 7.2.1.18.2 Residential features;
  - 7.2.1.18.3 Customer Local Area Signaling Services (CLASS/LASS);
  - 7.2.1.18.4 CENTREX (including equivalent administrative capabilities, such as customer accessible reconfiguration and detailed message recording); and
  - 7.2.1.18.5 Advanced intelligent network triggers supporting AT&T and BellSouth service applications.  
BellSouth shall offer to AT&T all AIN triggers which are supported by BellSouth for offering AIN-based services in accordance with the technical references in Section 7.2.1.23 of this Attachment. Triggers that are currently available include:
    - 7.2.1.18.5.1 Off-Hook Immediate
    - 7.2.1.18.5.2 Off-Hook Delay
    - 7.2.1.18.5.3 Termination Attempt



- 7.2.1.18.5.4 3/6/10 Public Office Dialing Plan
- 7.2.1.18.5.5 Feature Code Dialing
- 7.2.1.18.5.6 Customer Dialing Plan
- 7.2.1.18.6 When the following triggers are supported by BellSouth, BellSouth will make these triggers available to AT&T:
  - 7.2.1.18.6.1 Private EAMF Trunk
  - 7.2.1.18.6.2 Shared Interoffice Trunk (EAMF, SS7)
  - 7.2.1.18.6.3 N11
  - 7.2.1.18.6.4 Automatic Route Selection
- 7.2.1.19 BellSouth shall assign each AT&T customer line the class of service designated by AT&T (e.g., using line class codes or other switch specific provisioning methods), and shall route directory assistance calls from AT&T customers to AT&T directory assistance operators at AT&T's option.
- 7.2.1.20 BellSouth shall assign each AT&T customer line the class of services designated by AT&T (e.g., using line class codes or other switch specific provisioning methods) and shall route operator calls from AT&T customers to AT&T operators at AT&T's option. For example, BellSouth may translate 0- and 0+ intraLATA traffic, and route the call through appropriate trunks to an AT&T Operator Services Position System (OSPS). Calls from Local Switching must pass the ANI-II digits unchanged.
- 7.2.1.21 If AT&T requests disconnection of the Local Switching element, BellSouth shall disconnect promptly and remove all appropriate translations from BellSouth facilities.
- 7.2.1.22 If an AT&T customer subscribes to AT&T provided voice mail and messaging services, BellSouth shall redirect incoming calls to the AT&T system based upon presubscribed service arrangements (e.g., busy, don't answer, number of rings). In addition, BellSouth shall provide a Standard Message Desk Interface-Enhanced (SMDI-E) interface to the AT&T system. BellSouth shall support the Inter-switch Voice Messaging Service (IVMS) capability.
- 7.2.1.23 Local Switching shall be offered in accordance with the requirements of the following technical references:

- 7.2.1.23.1 GR-1298-CORE. AIN Switching System Generic Requirements as implemented in BellSouth's switching equipment;
- 7.2.1.23.2 GR-1299-CORE. AIN Switch-Service Control Point (SCP)/Adjunct Interface Generic Requirements;
- 7.2.1.23.3 TR-NWT-001284. AIN 0.1 Switching System Generic Requirements.
- 7.2.1.23.4 SR-NWT-002247. AIN Release 1 Update.
- 7.2.2 **Interface Requirements**
- 7.2.2.1 BellSouth shall provide the following interfaces to loops:
- 7.2.2.2 Standard Tip/Ring interface including loopstart or groundstart, on-hook signaling (e.g., for calling number, calling name and message waiting lamp);
- 7.2.2.3 Coin phone signaling;
- 7.2.2.4 Basic Rate Interface ISDN adhering to appropriate Bellcore Technical Requirements;
- 7.2.2.5 Two-wire analog interface to PBX;
  - 7.2.2.5.1 Four-wire analog interface to PBX;
- 7.2.2.6 Four-wire DS1 interface to PBX or customer provided equipment (e.g. computers and voice response systems);
- 7.2.2.7 Primary Rate ISDN to PBX adhering to ANSI standards Q.931, Q.932 and appropriate Bellcore Technical Requirements;
- 7.2.2.8 Switched Fractional DS1 with capabilities to configure Nx64 channels (where N = 1 to 24); and
- 7.2.2.9 Loops adhering to Bellcore TR-NWT-08 and TR-NWT-303 specifications to interconnect Digital Loop Carriers.
- 7.2.2.10 BellSouth shall provide access to the following but not limited to:
- 7.2.2.11 SS7 Signaling Network or Multi-Frequency trunking if requested by AT&T;
- 7.2.2.12 Interface to AT&T operator services systems or Operator Services through appropriate trunk interconnections for the system; and

7.2.2.13 interface to AT&T directory assistance services through the AT&T switched network or to Directory Assistance Services through the appropriate trunk interconnections for the system; and 950 access or other AT&T required access to interexchange carriers as requested through appropriate trunk interfaces.

### 7.3 Data Switching

The requirements set forth in this Section 7.3 apply only to the Data Switching function of Local Switching.

#### 7.3.1 Data Switching Technical Requirements

7.3.1.1 Data Switching includes the necessary cross-office connectivity to the DSX or other appropriate connection point where interconnection to transport, or a cross-connect device can occur. Wherever Data Switching interconnects across network boundaries, it shall be in accordance with Network-to-Network Interface standards.

#### 7.3.1.2 Frame Relay Functional Requirements

7.3.1.3 Frame Relay Data Switching shall provide Permanent Virtual Circuits (PVCs) in accordance with the core protocol in ANSI Standard T1.618 ("Core aspects of Frame Protocol for use with Frame Relay Bearer Service," ANSI Standard T1.618, October 1991).

7.3.1.4 Control procedures for PVC management that shall be provided by Data Switching over the UNI include at least the Local Management interface (LMI) (as described in "Frame Relay Specification with Extensions," Rev 1.0, Digital Equipment Corporation, Northern Telecom, Inc., and StrataCom, Inc., September 18, 1990), ANSI Standard T1.617: Annex D ("Signaling Specification for Frame Relay Bearer Service," ANSI Standard T1.617, October 1991), and ITU-T Recommendation Q.933: Annex A ("Digital subscriber Signaling System No. 1 - Signaling specification for frame mode bearer service," ITU-T Recommendation Q.933, March 1993) specifications.

7.3.1.5 Data Switching provided to AT&T shall be given equal priority to BellSouth's own traffic during overflow and congestion conditions. To control the flow of data through the network and to prevent congestion of shared resources, Data Switching shall perform traffic management and policing functions on the ingress of data (flowing from customer into the network) and the egress of data (flowing from the network out to the customer). Traffic management is the mechanism used by Data Switching to prevent and reduce congestion within the network, such as buffering data and discarding data when buffers overflow, and may be performed on ingress or egress. Traffic policing is the enforcement by

Data Switching of the contracted rate for the ingress of data, described in terms of several parameters such as Peak Rate, Committed Rate, and Burst Size. Traffic management and policing performed at ingress and egress on AT&T's traffic shall be at parity with that performed on BellSouth's traffic.

- 7.3.1.6 As systems development allows, Data Switching shall provide remote data access to integrated test equipment and other integrated functionality on a demand basis in accordance with the following:
- 7.3.1.7 Real-time, remote data access to systems that enable the determination of Data Link Connection Identifiers (DLCIs) used by a PVC;
- 7.3.1.8 Real-time, remote data access to performance monitoring and alarm data on events affecting (or potentially affecting) AT&T's traffic; and
- 7.3.1.9 Real-time, remote data access to maintenance systems to enable end-to-end (customer site-to-customer site) performance and error testing.
- 7.3.1.10 BellSouth shall provision and maintain the underlying facilities required to provide Data Switching.
- 7.3.1.11 **Frame Relay Interface Requirements**
- 7.3.1.12 From Customer Premises Equipment (CPE), AT&T's Customers may interconnect to Data Switching using the transmission speeds, formats, and protocols as specified in the Frame Relay Forum Implementation Agreement 1 (FRF-1.1) ("User-to-Network Implementation Agreement (UNI)," FRF-1.1, Frame Relay Forum Technical Committee, January 18, 1996) and the standards cited in that document for the physical layer, data transfer, and control procedures. This includes, but is not limited to, access circuits at fractional T1 rates (56Kbps, Nx64 Kbps, (where N is 1 to 24)), T1, and T3.
- 7.3.1.13 Each T1 UNI interface port shall provide at least 250 PVCs or the appropriate number of PVC's allowed by the platform.
- 7.3.1.14 T1 interfaces shall be provided using Extended SuperFrame (ESF) format, for enhanced error monitoring and to aid in sectionalizing problems.
- 7.3.1.15 **NNI Interface B Requirements**
- 7.3.1.16 Data Switching shall interconnect across network boundaries using the Network-to-Network Interface standards as specified in Frame Relay Forum Implementation Agreement 2 (FRF-2.1) ("Network -to-Network

Implementation Agreement (NNI) (FRF-2.1 Frame Relay Forum Technical Committee, July 10, 1995) for the physical layer, data transfer and control (signaling) procedures. This standard includes both DS1 and DS3 among its listed physical interface formats.

- 7.3.1.17 Each T1 NNI should be capable of providing at least 200 PVCs; each T3 NNI should be capable of providing at least 1700 PVCs or the appropriate number of PVC's allowed by the platform.
- 7.3.1.18 **DELETED**
- 7.3.1.19 **DELETED**
- 7.3.1.20 **ATM Functional Requirements:** When ATM functionality becomes available, BellSouth will provide these functions to AT&T. In addition, BellSouth agrees to conform to industry standard (e.g. Bellcore standards).
  - 7.3.1.20.1 **DELETED**
  - 7.3.1.20.2 **DELETED**
  - 7.3.1.20.3 **DELETED**
    - 7.3.1.20.3.1 **DELETED**
    - 7.3.1.20.3.2 **DELETED**
    - 7.3.1.20.3.3 **DELETED**
  - 7.3.1.20.4 **DELETED**
  - 7.3.1.20.5 **DELETED**
- 7.3.1.21 **DELETED**
  - 7.3.1.21.1 **DELETED**
    - 7.3.1.21.1.1 **DELETED**
    - 7.3.1.21.1.2 **DELETED**
  - 7.3.1.21.2 **DELETED**
  - 7.3.1.21.3 **DELETED**
  - 7.3.1.21.4 **DELETED**

- 7.3.1.21.4.1 DELETED
- 7.3.1.21.4.2 DELETED
- 7.3.1.21.4.3 DELETED
- 7.3.1.21.4.4 DELETED
- 7.3.1.21.4.5 DELETED
- 7.3.1.21.4.6 DELETED
- 7.3.1.21.5 DELETED
- 7.3.1.21.6 DELETED
- 7.3.1.21.6.1 DELETED
- 7.3.1.21.6.2 DELETED
- 7.3.1.21.6.3 DELETED
- 7.3.1.21.6.4 DELETED
- 7.3.1.21.6.5 DELETED
- 7.3.1.21.6.6 DELETED
- 7.3.1.21.6.7 DELETED
- 7.3.1.21.6.7.1 DELETED
- 7.3.1.21.6.7.2 DELETED
- 7.3.1.21.6.7.3 DELETED
- 7.3.1.21.6.8 DELETED

**7.3.1.22 Integrated Services Digital Network (ISDN)**

Integrated Services Digital Network (ISDN) is defined in two variations. The first variation is Basic Rate ISDN (BRI). BRI consists of 2 Bearer (B) Channels and one Data (D) Channel. The second variation is Primary Rate ISDN (PRI). PRI consists of 23 B Channels and one D Channel. Both BRI and PRI B Channels may be used for voice, Circuit Switched Data (CSD) or Packet Switched Data (PSD). The BRI D Channel may be used for call related signaling, non-call related signaling or packet

switched data. The PRI D Channel may be used for call related signaling.

- 7.3.1.22.1 Technical Requirements - ISDN
- 7.3.1.22.2 BellSouth shall offer Data Switching providing ISDN that, at a minimum
- 7.3.1.22.3 Provides integrated packet handling capabilities;
- 7.3.1.22.4 Allows for full 2B+D Channel functionality for BRI; and
- 7.3.1.22.5 Allows for full 23B+D Channel functionality for PRI.
- 7.3.1.22.6 Each B Channel shall allow for voice, 64Kbs CSD, and PSD of 128 logical channels at minimum speeds of 19Kbs throughput of each logical channel up to the total capacity of the B Channel.
- 7.3.1.22.7 Each B Channel shall provide capabilities for alternate voice and data on a per call basis.
- 7.3.1.22.8 The BRI D Channel shall allow for call associated signaling, non-call associated signaling and PSD of 16 logical channels at minimum speeds of 9.6 Kbs throughput of each logical channel up to the total capacity of the D Channel.
- 7.3.1.22.9 The PRI D Channel shall allow for call associated signaling.
- 7.3.1.22.10 Interface Requirements - ISDN
- 7.3.1.22.11 BellSouth shall provide the BRI U interface using 2 wire copper loops in accordance with TR-NWT-000393, January 1991, *Generic Requirements for ISDN Basic Access Digital Subscriber Lines*.
- 7.3.1.22.12 BellSouth shall provide the BRI interface using Digital Subscriber Loops adhering to Bellcore TR-NWT-303 specifications to interconnect Digital Loop Carriers.
- 7.3.1.22.13 BellSouth shall offer PSD interfaces adhering to the X.25, S.75 and S.75' ANSI and Bellcore requirements.
- 7.3.1.22.14 BellSouth shall offer PSD trunk interfaces operating at 56Kbs.

## 8. Operator Systems

### 8.1 Definition

Operator Systems is the Network Element that provides operator and automated call handling and billing, special services, customer telephone listings and optional call completion services. The Operator Systems Network Element provides two types of functions: Operator Service functions and Directory Assistance Service functions, each of which are described in detail below.

**8.2 Operator Service**

**8.2.1 Definition**

Operator Service provides: (1) operator handling for call completion (for example, collect, third number billing, and manual credit card calls); (2) operator or automated assistance for billing after the customer has dialed the called number (for example, credit card calls); and (3) special services including but not limited to Busy Line Verification and Emergency Line Interrupt (ELI), Emergency Agency Call, Operator-assisted Directory Assistance, and Rate Quotes.

**8.2.2 Requirements**

**8.2.2.1** When AT&T requests BellSouth to provide Operator Services, the following requirements apply:

**8.2.2.1.1** BellSouth shall complete 0+ and 0- dialed local calls.

**8.2.2.1.2** BellSouth shall complete 0+ intraLATA toll calls.

**8.2.2.1.3** BellSouth shall complete calls that are billed to an AT&T customer's calling card that can be validated by BellSouth.

**8.2.2.1.4** BellSouth shall complete person-to-person calls.

**8.2.2.1.5** BellSouth shall complete collect calls.

**8.2.2.1.6** BellSouth shall provide the capability for callers to bill to a third party and complete such calls.

**8.2.2.1.7** BellSouth shall complete station-to-station calls.

**8.2.2.1.8** BellSouth shall process emergency calls.

**8.2.2.1.9** BellSouth shall process Busy Line Verify and Emergency Line Interrupt requests.



- 8.2.2.1.10 BellSouth shall process emergency call trace as they do for their Customers prior to the Effective Date. Call must originate from a 911 provider.
- 8.2.2.1.11 BellSouth shall process operator-assisted directory assistance calls.
- 8.2.2.1.12 DELETED
- 8.2.2.1.13 DELETED
- 8.2.2.1.14 BellSouth will provide the ability for an AT&T Customer to reach a "live" operator on a 0-call.
- 8.2.2.1.15 BellSouth shall brand Operator Service as specified by AT&T in Section 19 of the General Terms and Conditions of this Agreement.
- 8.2.2.2 DELETED
- 8.2.2.3 BellSouth shall adhere to equal access requirements, providing AT&T local customers the same IXC access as provided to BellSouth customers.
- 8.2.2.4 BellSouth shall exercise at least the same level of fraud control in providing Operator Service to AT&T that BellSouth provides for its own operator service.
- 8.2.2.5 BellSouth shall perform Billed Number Screening when handling Collect, Person-to-Person, and Billed-to-Third-Party calls.
- 8.2.2.6 DELETED
- 8.2.2.7 BellSouth shall direct customer account and other similar inquiries to the customer service center designated by AT&T.
- 8.2.2.8 BellSouth shall provide an electronic feed of customer call records in "EMR" format to AT&T in accordance with the time schedule designated by AT&T.
- 8.2.2.9 DELETED
- 8.2.3 **Interface Requirements:**  
With respect to Operator Services for calls that originate on local switching capability provided by or on behalf of AT&T, the interface requirements shall conform to the then current established system interface specifications for the platform used to provide Operator Service and the interface shall conform to industry standards.

- 8.3 **Directory Assistance Service**
- 8.3.1 **Definition**

Directory Assistance Service provides local customer telephone number listings with the option to complete the call at the callers direction separate and distinct from local switching.
- 8.3.2 **Requirements**
- 8.3.2.1 Directory Assistance Service shall provide up to two listing requests per call. If available and if requested by AT&T's customer, BellSouth shall provide caller-optional directory assistance call completion service to one of the provided listings, equal to that which BellSouth provides its customers. If not available, AT&T may request such requirement pursuant to the Bona Fide Request Process provided for in Attachment 14 of this Agreement.
- 8.3.2.2 BellSouth shall brand Directory Assistance Service as specified by AT&T in Section 19 of the General Terms and Conditions of this Agreement.
- 8.3.2.3 **DELETED**
- 8.3.2.4 **DELETED**
- 8.3.2.5 **Directory Assistance Service Updates**
- 8.3.2.5.1 BellSouth shall update customer listings changes daily. These changes include:
  - 8.3.2.5.1.1 New customer connections: BellSouth will provide service to AT&T that is equal to the service it provides to itself and its customers;
  - 8.3.2.5.1.2 Customer disconnections: BellSouth will provide service to AT&T that is equal to the service it provides to itself and its customers; and
  - 8.3.2.5.1.3 Customer address changes: BellSouth will provide service to AT&T that is equal to the service it provides to itself and its customers;
- 8.3.2.6 These updates shall also be provided for non-listed and non-published numbers for use in emergencies.
- 9. **Common Transport**
- 9.1 **Definition**

  
FL6/10/97

Common Transport is an interoffice transmission path between BellSouth Network Elements (illustrated in Figure 2). Where BellSouth Network Elements are connected by intra-office wiring, such wiring is provided as a part of the Network Elements and is not Common Transport. Common Transport consists of BellSouth inter-office transport facilities and is unbundled from local switching.

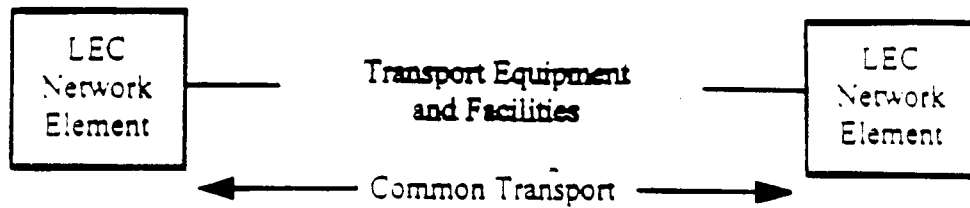

Figure 2

## 9.2 Technical Requirements

- 9.2.1 Common Transport provided on DS1 or VT1.5 circuits, shall, at a minimum, meet the performance, availability, jitter, and delay requirements specified for Central Office to Central Office "CO to CO" connections in the technical reference set forth in Section 9.2.4.31 of this Attachment 2.
- 9.2.2 Common Transport provided on DS3 circuits, STS-1 circuits, and higher transmission bit rate circuits, Common Transport shall, at a minimum, meet the performance, availability, jitter, and delay requirements specified for Central Office to Central Office "CO to CO" connections in the technical reference set forth in Section 9.2.4.30 of this Attachment 2.
- 9.2.3 BellSouth shall be responsible for the engineering, provisioning, and maintenance of the underlying equipment and facilities that are used to provide Common Transport.
- 9.2.4 At a minimum, Common Transport shall meet all of the requirements set forth in the following technical references (as applicable for the transport technology being used):
- 9.2.4.1 ANSI T1.101-1994, American National Standard for Telecommunications - Synchronization Interface Standard Performance and Availability;
- 9.2.4.2 ANSI T1.102-1993, American National Standard for Telecommunications - Digital Hierarchy - Electrical Interfaces;
- 9.2.4.3 ANSI T1.102.01-199x, American National Standard for Telecommunications - Digital Hierarchy - VT1.5;

*UB*

- 9.2.4.4 ANSI T1.105-1995, American National Standard for Telecommunications - Synchronous Optical Network (SONET) - Basic Description, including Multiplex Structure, Rates and Formats;
- 9.2.4.5 ANSI T1.105.01-1995, American National Standard for Telecommunications - Synchronous Optical Network (SONET) - Automatic Protection Switching;
- 9.2.4.6 ANSI T1.105.02-1995, American National Standard for Telecommunications - Synchronous Optical Network (SONET) - Payload Mappings;
- 9.2.4.7 ANSI T1.105.03-1994, American National Standard for Telecommunications - Synchronous Optical Network (SONET) - Jitter at Network Interfaces;
- 9.2.4.8 ANSI T1.105.03a-1995, American National Standard for Telecommunications - Synchronous Optical Network (SONET): Jitter at Network Interfaces - DS1 Supplement;
- 9.2.4.9 ANSI T1.105.05-1994, American National Standard for Telecommunications - Synchronous Optical Network (SONET) - Tandem Connection;
- 9.2.4.10 ANSI T1.105.06-199x, American National Standard for Telecommunications - Synchronous Optical Network (SONET) - Physical Layer Specifications;
- 9.2.4.11 ANSI T1.105.07-199x, American National Standard for Telecommunications - Synchronous Optical Network (SONET) - Sub STS-1 Interface Rates and Formats;
- 9.2.4.12 ANSI T1.105.09-199x, American National Standard for Telecommunications - Synchronous Optical Network (SONET) - Network Element Timing and Synchronization;
- 9.2.4.13 ANSI T1.106-1988, American National Standard for Telecommunications - Digital Hierarchy - Optical Interface Specifications (Single Mode);
- 9.2.4.14 ANSI T1.107-1988, American National Standard for Telecommunications - Digital Hierarchy - Formats Specifications;
- 9.2.4.15 ANSI T1.107a-1990 - American National Standard for Telecommunications - Digital Hierarchy - Supplement to Formats Specifications (DS3 Format Applications);

- 9.2.4.16 ANSI T1.107b-1991 - American National Standard for Telecommunications - Digital Hierarchy - Supplement to Formats Specifications;
- 9.2.4.17 ANSI T1.117-1991, American National Standard for Telecommunications - Digital Hierarchy - Optical Interface Specifications (SONET) (Single Mode - Short Reach);
- 9.2.4.18 ANSI T1.403-1989, Carrier to Customer Installation, DS1 Metallic Interface Specification;
- 9.2.4.19 ANSI T1.404-1994, Network-to-Customer Installation - DS3 Metallic Interface Specification;
- 9.2.4.20 ITU Recommendation G.707, Network node interface for the synchronous digital hierarchy (SDH);
- 9.2.4.21 ITU Recommendation G.704, Synchronous frame structures used at 1544, 6312, 2048, 8488 and 44736 kbit/s hierarchical levels;
- 9.2.4.22 Bellcore FR-440 and TR-NWT-000499, Transport Systems Generic Requirements (TSGR): Common Requirements;
- 9.2.4.23 Bellcore GR-820-CORE, Generic Transmission Surveillance: DS1 & DS3 Performance;
- 9.2.4.24 Bellcore GR-253-CORE, Synchronous Optical Network Systems (SONET); Common Generic Criteria;
- 9.2.4.25 Bellcore TR-NWT 000507, Transmission, Section 7, Issue 5 (Bellcore, December 1993). (A module of LSSGR, FR-NWT-000064.);
- 9.2.4.26 Bellcore TR-NWT-000776, Network Interface Description for ISDN Customer Access;
- 9.2.4.27 Bellcore TR-INS-000342, High-Capacity Digital Special Access Service-Transmission Parameter Limits and Interface Combinations, Issue 1 February 1991;
- 9.2.4.28 Bellcore ST-TEC 000052, Telecommunications Transmission Engineering Textbook, Volume 2: Facilities, Third Edition, Issue 1 May 1989;
- 9.2.4.29 Bellcore ST-TEC-000051, Telecommunications Transmission Engineering Textbook Volume 1: Principles, Third Edition, Issue 1 August 1987;

*UB*

- 9.2.4.30 AT&T Technical Reference 54014, ACCUNET T45 Service Description and Interface Specification, May 1992, and
- 9.2.4.31 AT&T Technical Reference TR 62411, ACCUNET T1.5 Service Description And Interface Specification, December 1990 and all addenda.

10. Dedicated Transport

10.1 Definition

10.1.1 Dedicated Transport is an interoffice transmission path between AT&T designated locations unbundled from local switching. AT&T designated locations may include BellSouth central offices or other equipment locations, AT&T network components, other carrier network components, or customer premises. Dedicated Transport is depicted below in Figure 3.

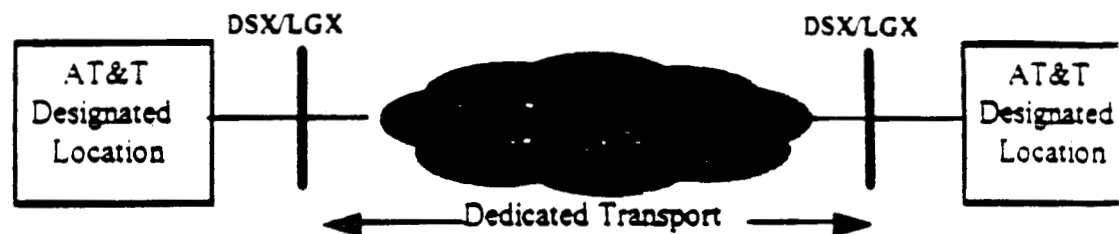

Figure 3

- 10.1.2 BellSouth shall offer Dedicated Transport in each of the following ways:
  - 10.1.2.1 As capacity on a shared circuit.
  - 10.1.2.2 As a circuit (e.g., DS1, DS3, STS-1) dedicated to AT&T.
  - 10.1.2.3 As a system (i.e., the equipment and facilities used to provide Dedicated Transport such as SONET ring) dedicated to AT&T.
- 10.1.3 When Dedicated Transport is provided as a circuit or as capacity on a shared circuit, it shall include (as appropriate):
  - 10.1.3.1 Multiplexing functionality;
  - 10.1.3.2 Grooming functionality; and
  - 10.1.3.3 Redundant equipment and facilities necessary to support protection and restoration.

UB  
FL6/10/97

- 10.1.4 When Dedicated Transport is provided as a system it shall include
  - 10.1.4.1 Transmission equipment such as multiplexers, line terminating equipment, amplifiers, and regenerators;
  - 10.1.4.2 Inter-office transmission facilities such as optical fiber, copper twisted pair, and coaxial cable;
  - 10.1.4.3 Redundant equipment and facilities necessary to support protection and restoration; and
  - 10.1.4.4 Dedicated Transport includes the Digital Cross-Connect System (DCS) functionality as an option. DCS is described below in Section 10.5 of this Attachment.

10.2 **Technical Requirements**

This Section sets forth technical requirements for all Dedicated Transport.

- 10.2.1 When BellSouth provides Dedicated Transport as a circuit or a system, the entire designated transmission circuit or system (e.g., DS1, DS3, STS-1) shall be dedicated to AT&T designated traffic.
- 10.2.2 BellSouth shall offer Dedicated Transport in all technologies that become available during the life of the contract including, but not limited to, DS1 and DS3 transport systems, SONET (or SDH) Bi-directional Line Switched Rings, SONET (or SDH) Unidirectional Path Switched Rings, and SONET (or SDH) point-to-point transport systems (including linear add-drop systems), at all available transmission bit rates.
- 10.2.3 For DS1 or VT1.5 circuits, Dedicated Transport shall, at a minimum, meet the performance, availability, jitter, and delay requirements specified for Customer Interface to Central Office "CI to CO" connections in the technical references set forth in Section 10.4 of this Attachment.
- 10.2.4 For DS3 circuits, STS-1 circuits, and higher rate circuits, Dedicated Transport shall, at a minimum, meet the performance, availability, jitter, and delay requirements specified for Customer Interface to Central Office "CI to CO" connections in the technical references set forth in Section 10.4 of this Attachment.
- 10.2.5 When requested by AT&T, Dedicated Transport shall provide physical diversity. Physical diversity means that two circuits are provisioned in such a way that no single failure of facilities or equipment will cause a failure on both circuits.

- 10.2.6 When physical diversity is requested by AT&T, BellSouth shall provide the maximum feasible physical separation between intra-office and inter-office transmission paths (unless otherwise agreed by AT&T).
- 10.2.7 Upon AT&T's request, BellSouth shall provide real time and continuous remote access to performance monitoring and alarm data affecting, or potentially affecting, AT&T's traffic.
- 10.2.8 BellSouth shall offer the following interface transmission rates for Dedicated Transport:
- 10.2.8.1 DS1 (Extended SuperFrame - ESF, D4, and unframed applications shall be provided);
- 10.2.8.2 DS3 (C-bit Parity, M13, and unframed applications shall be provided);
- 10.2.8.3 SONET standard interface rates in accordance with ANSI T1.105 and ANSI T1.105.07 and physical interfaces per ANSI T1.106.06 (including referenced interfaces). In particular, VT1.5 based STS-1s will be the interface at an AT&T service node.
- 10.2.8.4 SDH Standard interface rates in accordance with International Telecommunications Union (ITU) Recommendation G.707 and Plesiochronous Digital Hierarchy (PDH) rates per ITU Recommendation G.704.
- 10.2.9 BellSouth shall provide cross-office wiring up to a suitable Point of Termination (POT) between Dedicated Transport and AT&T designated equipment. BellSouth shall provide the following equipment for the physical POT:
- 10.2.9.1 DSX1 for DS1s or VT1.5s;
- 10.2.9.2 DSX3 for DS3s or STS-1s; and
- 10.2.9.3 LGX for optical signals (e.g., OC-3 and OC-12)
- 10.2.10 **DELETED**
- 10.2.11 When Dedicated Transport is provided as a system, BellSouth shall design the system according to AT&T's architectural requirements. This includes, but is not limited to:
1. Facility routing and termination points (including diversity requirements),
  2. Interface selection among those available on the system.

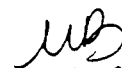
  
FL6/10/97



3. System provisionable parameters (e.g. protection switching thresholds). This does not include specification of the vendor to be used by BellSouth, except where mutually agreed.
- 10.2.12 Upon AT&T's request, BellSouth shall provide AT&T with electronic provisioning control of AT&T rings. As system development allows, BellSouth shall provide this functionality in other transport systems (e.g. linear transport systems.)
- 10.2.13 BellSouth shall offer Dedicated Transport together with and separately from DCS.
- 10.3 **Technical Requirements for Dedicated Transport Using SONET technology.**  
This Section sets forth additional technical requirements for Dedicated Transport using SONET technology including rings, point-to-point systems, and linear add-drop systems.
- 10.3.1 **All SONET Dedicated Transport provided as a system shall:**
- 10.3.1.1 **Be synchronized from both a primary and secondary Stratum 1 level timing source. Additional detail on synchronization requirements are given in Section 16.4 of this Attachment 2.**
- 10.3.1.2 **Provide SONET standard interfaces which properly interwork with SONET standard equipment from other vendors. This includes, but is not limited to, SONET standard Section, Line, and Path performance monitoring, maintenance signals, alarms, and data channels.**
- 10.3.1.3 **Provide Data Communications Channel (DCC) or equivalent connectivity through the SONET transport system. Dedicated Transport provided over a SONET transport system shall be capable of routing DCC messages between AT&T SONET network components connected to the Dedicated Transport. For example, if AT&T leases a SONET ring from BellSouth, that ring shall support DCC message routing between AT&T SONET network components connected to the ring.**
- 10.3.1.4 **Support the following performance requirements for each circuit (STS-1, DS1, DS3, etc.):**
- 10.3.1.5 **No more than 10 Errored Seconds Per Day (Errored Seconds are defined in the technical reference at Section 10.4.5 of this Attachment); and**

UB

- 10.3.1.6 No more than 1 Severely Errored Second Per Day (Severely Errored Seconds are defined in the technical reference at Section 10.4.5 of this Attachment).
- 10.3.1.7 All SONET rings shall:
  - 10.3.1.8 Be provisioned on physically diverse fiber optic cables (including separate building entrances where available and diversely routed intra-office wiring). "Diversely routed" shall be interpreted as the maximum feasible physical separation between transmission paths, unless otherwise agreed by AT&T.
  - 10.3.1.9 Support dual ring interworking per SONET Standards.
  - 10.3.1.10 To the extent technically feasible, BellSouth shall provide the necessary redundancy in optics, electronics, and transmission paths (including intra-office wiring) such that no single failure will cause a service interruption.
  - 10.3.1.11 Provide the ability to disable ring protection switching at AT&T's direction (selective protection lock-out), if BellSouth's SONET equipment provides this functionality. This requirement applies to line switched rings only.
  - 10.3.1.12 Provide the ability to use the protection channels to carry traffic (extra traffic), if BellSouth's SONET equipment provides this functionality. This requirement applies to line switched rings only.
  - 10.3.1.13 Provide 50 millisecond restoration unless a ring protection delay is set to accommodate dual ring interworking schemes.
  - 10.3.1.14 Have settable ring protection switching thresholds that shall be set in accordance with AT&T's specifications.
  - 10.3.1.15 Provide revertive protection switching with a settable wait to restore delay with a default setting of 5 minutes. This requirement applies to line switched rings only.
  - 10.3.1.16 Provide non-revertive protection switching. This requirement applies to path switched rings only.
  - 10.3.1.17 Adhere to the following availability requirements, where availability is defined in the technical reference set forth in Section 10.4.5 of this Attachment.
    - 10.3.1.17.1 For any circuit through the ring, no more than 3.5 minutes of unavailability per month.

*JB*  
FL6/10/97

- 10.3.1.17.2 For any circuit through the ring, no more than 10 minutes of unavailability per year
- 10.4 At a minimum, Dedicated Transport shall meet each of the requirements set forth in Section 9.2.4 of this Attachment and in the following technical references:
- 10.4.1 ANSI T1.105.04-1995, American National Standard for Telecommunications - Synchronous Optical Network (SONET) - Data Communication Channel Protocols and Architectures;
- 10.4.2 ANSI T1.119-1994, American National Standard for Telecommunications - Synchronous Optical Network (SONET) - Operations, Administration, Maintenance, and Provisioning (OAM&P) Communications;
- 10.4.3 ANSI T1.119.01-1995, American National Standard for Telecommunications - Synchronous Optical Network (SONET) - Operations, Administration, Maintenance, and Provisioning (OAM&P) Communications Protection Switching Fragment;
- 10.4.4 ANSI T1.119.02-199x, American National Standard for Telecommunications - Synchronous Optical Network (SONET) - Operations, Administration, Maintenance, and Provisioning (OAM&P) Communications Performance Monitoring Fragment;
- 10.4.5 ANSI T1.231-1993 -American National Standard for Telecommunications - Digital Hierarchy - Layer 1 In-Service Digital Transmission performance monitoring.
- 10.4.6 AT&T Technical Reference TR 54016, Requirements For Interfacing Digital Terminal Equipment To Services Employing The Extended Superframe Format, September 1989, where the underlying equipment used by BellSouth to provide unbundled dedicated transport supports this functionality;
- 10.4.7 **DELETED**
- 10.4.8 AT&T Technical Reference TR 62310, DS0 Digital Local Channel Description And Interface Specification, August 1993 and all addenda, where the underlying equipment used by BellSouth to provide unbundled dedicated transport supports this functionality;
- 10.4.9 AT&T Technical Reference TR 62415, Access Specification For High Capacity (DS1/DS3) Dedicated Digital Service, June 1989 and all addenda;

- 10.4.9.1 ANSI T1.101-1994, American National Standard for Telecommunications - Synchronization Interface Standard Performance and Availability
- 10.4.9.2 ANSI T1.102-1993, American National Standard for Telecommunications - Digital Hierarchy - Electrical Interfaces;
- 10.4.9.3 ANSI T1.102.01-199x, American National Standard for Telecommunications - Digital Hierarchy - VT1.5;
- 10.4.9.4 ANSI T1.105-1995, American National Standard for Telecommunications - Synchronous Optical Network (SONET) - Basic Description including Multiplex Structure, Rates and Formats;
- 10.4.9.5 ANSI T1.105.01-1995, American National Standard for Telecommunications - Synchronous Optical Network (SONET) - Automatic Protection Switching;
- 10.4.9.6 ANSI T1.105.02-1995, American National Standard for Telecommunications - Synchronous Optical Network (SONET) - Payload Mappings;
- 10.4.9.7 ANSI T1.105.03-1994, American National Standard for Telecommunications - Synchronous Optical Network (SONET) - Jitter at Network Interfaces;
- 10.4.9.8 ANSI T1.105.03a-1995, American National Standard for Telecommunications - Synchronous Optical Network (SONET): Jitter at Network Interfaces - DS1 Supplement;
- 10.4.9.9 ANSI T1.105.05-1994, American National Standard for Telecommunications - Synchronous Optical Network (SONET) - Tandem Connection;
- 10.4.9.10 ANSI T1.105.06-199x, American National Standard for Telecommunications - Synchronous Optical Network (SONET) - Physical Layer Specifications;
- 10.4.9.11 ANSI T1.105.07-199x, American National Standard for Telecommunications - Synchronous Optical Network (SONET) - Sub STS-1 Interface Rates and Formats;
- 10.4.9.12 ANSI T1.105.09-199x, American National Standard for Telecommunications - Synchronous Optical Network (SONET) - Network Element Timing and Synchronization;
- 10.4.9.13 ANSI T1.106-1988, American National Standard for Telecommunications - Digital Hierarchy - Optical Interface Specifications (Single Mode);

- 10.4.9.14 ANSI T1.107-1988, American National Standard for Telecommunications - Digital Hierarchy - Formats Specifications;
- 10.4.9.15 ANSI T1.107a-1990 - American National Standard for Telecommunications - Digital Hierarchy - Supplement to Formats Specifications (DS3 Format Applications);
- 10.4.9.16 ANSI T1.107b-1991 - American National Standard for Telecommunications - Digital Hierarchy - Supplement to Formats Specifications;
- 10.4.9.17 ANSI T1.117-1991, American National Standard for Telecommunications - Digital Hierarchy - Optical Interface Specifications (SONET) (Single Mode - Short Reach);
- 10.4.9.18 ANSI T1.403-1989, Carrier to Customer Installation, DS1 Metallic Interface Specification;
- 10.4.9.19 ANSI T1.404-1994, Network-to-Customer Installation - DS3 Metallic Interface Specification;
- 10.4.9.20 ITU Recommendation G.707, Network node interface for the synchronous digital hierarchy (SDH);
- 10.4.9.21 ITU Recommendation G.704, Synchronous frame structures used at 1544, 6312, 2048, 8488 and 44736 kbit/s hierarchical levels;
- 10.4.9.22 Bellcore FR-440 and TR-NWT-000499, Transport Systems Generic Requirements (TSGR): Common Requirements;
- 10.4.9.23 Bellcore GR-820-CORE, Generic Transmission Surveillance: DS1 & DS3 Performance;
- 10.4.9.24 Bellcore GR-253-CORE, Synchronous Optical Network Systems (SONET); Common Generic Criteria;
- 10.4.9.25 Bellcore TR-NWT 000507, Transmission, Section 7, Issue 5 (Bellcore, December 1993). (A module of LSSGR, FR-NWT-000064.);
- 10.4.9.26 Bellcore TR-NWT-000776, Network Interface Description for ISDN Customer Access;
- 10.4.9.27 Bellcore TR-INS-000342, High-Capacity Digital Special Access Service-Transmission Parameter Limits and Interface Combinations, Issue 1 February 1991;

*MB*

- 10.4.9.28 Bellcore ST-TEC 000052, Telecommunications Transmission Engineering Textbook, Volume 2: Facilities, Third Edition, Issue 1 May 1989;
- 10.4.9.29 Bellcore ST-TEC-000051, Telecommunications Transmission Engineering Textbook Volume 1: Principles, Third Edition, Issue 1 August 1987;
- 10.4.9.30 AT&T Technical Reference 54014 ACCUNET T45 Service Description and Interface Specification, May 1992; and
- 10.4.9.31 AT&T Technical Reference TR 62411 ACCUNET T1.5 Service Description And Interface Specification, December 1990 and all addenda.
- 10.5 **Digital Cross-Connect System (DCS)**
  - 10.5.1 **Definition**
    - 10.5.1.1 DCS provides automated cross connection of Digital Signal level 0 (DS0) or higher transmission bit rate digital channels within physical interface facilities. Types of DCSs include but are not limited to DCS 1/0s, DCS 3/1s, and DCS 3/3s, where the nomenclature 1/0 denotes interfaces typically at the DS1 rate or greater with cross-connection typically at the DS0 rate. This same nomenclature, at the appropriate rate substitution, extends to the other types of DCSs specifically cited as 3/1 and 3/3. Types of DCSs that cross-connect Synchronous Transport Signal level 1 (STS-1s) or other Synchronous Optical Network (SONET) signals (e.g., STS-3) are also DCSs, although not denoted by this same type of nomenclature. DCS may provide the functionality of more than one of the aforementioned DCS types (e.g., DCS 3/3/1 which combines functionality of DCS 3/3 and DCS 3/1). For such DCSs, the requirements will be, at least, the aggregation of requirements on the "component" DCSs.
    - 10.5.1.2 In locations where automated cross connection capability does not exist, DCS will be defined as the combination of the functionality provided by a Digital Signal Cross-Connect (DSX) or Light Guide Cross-Connect (LGX) patch panels and D4 channel banks or other DS0 and above multiplexing equipment used to provide the function of a manual cross connection.
    - 10.5.1.3 Interconnection between a DSX or LGX, to a switch, another cross-connect, or other service platform device, is included as part of DCS.
  - 10.6 **DCS Technical Requirements**

- 10.6.1 DCS shall provide completed end-to-end cross connection of the channels designated by AT&T
- 10.6.2 DCS shall perform facility grooming, multipoint bridging, one-way broadcast, two-way broadcast. Upon request by AT&T pursuant to the Bona Fide Request Process, BellSouth will provide AT&T with access to integrated test functionality on the DCS subject to vendor development that will allow sharing of such functionality among multiple users and that will include necessary security features.
- 10.6.3 Where technically available in BellSouth's DCS system and supported by BellSouth's network management software, DCS shall provide multiplexing, format conversion, signaling conversion, or other functions.
- 10.6.4 The end-to-end cross connection assignment shall be input to the underlying device used to provide DCS from an operator at a terminal or via an intermediate system. The cross connection assignment shall remain in effect whether or not the circuit is in use.
- 10.6.5 BellSouth shall continue to administer and maintain DCS, including updates to the control software to current available releases.
- 10.6.6 BellSouth shall provide various types of Digital Cross-Connect Systems including:
  - 10.6.6.1 DS0 cross-connects (typically termed DCS 1/0);
  - 10.6.6.2 DS1/VT1.5 (Virtual Tributaries at the 1.5Mbps rate) cross-connects (typically termed DCS 3/1);
  - 10.6.6.3 DS3 cross-connects (typically termed DCS 3/3);
  - 10.6.6.4 STS-1 cross-connects; and
  - 10.6.6.5 Other technically feasible cross-connects designated by AT&T.
- 10.6.7 BellSouth shall provide an automated interface which will allow AT&T to, in real time, control the configuration and reconfiguration of channels on the DCS.
- 10.6.8 **DELETED**
- 10.6.9 DCS shall continuously monitor protected circuit packs and redundant common equipment.

UB

FL6/10/97

- 10.6.10 Where technically available in BellSouth's DCS System, DCS shall automatically switch to a protection circuit back on detection of a failure or degradation of normal operation.
- 10.6.11 The underlying equipment used to provide DCS shall be equipped with a redundant power supply or a battery back-up.
- 10.6.12 BellSouth shall make available to AT&T spare facilities and equipment necessary for provisioning repairs, as it does for itself and for its own customers.
- 10.6.13 Effective as of the date this unbundled network element is offered, BellSouth will perform network management functions twenty-four (24) hours a day seven (7) days a week via electronic interfaces between AT&T and BellSouth network management centers. At AT&T's option, BellSouth shall provide AT&T with real time performance monitoring and alarm data on the signals and the components of the underlying equipment used to provide DCS that actually impact AT&T's services.
- 10.6.14 Upon request by AT&T pursuant to Bona Fide Request Process, BellSouth shall provide AT&T with real time ability to initiate tests on integrated equipment used to test the signals and the underlying equipment used to provide DCS, as well as other integrated functionality for routine testing and fault isolation. Until such real time ability is available, BellSouth will perform such testing if requested by AT&T.
- 10.6.15 Where technically available in BellSouth's DCS System and supported by BellSouth's network management software, DCS shall provide SONET to asynchronous gateway functionality (e.g., STS-1 to DS1 or STS-1 to DS3).
- 10.6.16 Where technically available in BellSouth's DCS System and supported by BellSouth's network management software, DCS shall perform optical to electrical conversion where the underlying equipment used to provide DCS contains optical interfaces or terminations (e.g., Optical Carrier level 3, i.e., OC-3, interfaces on a DCS 3/1).
- 10.6.17 Where technically available in BellSouth's DCS System and supported by BellSouth's network management software, DCS shall have SONET ring terminal functionality where the underlying equipment used to provide DCS acts as a terminal on a SONET ring.
- 10.6.18 Where technically available in BellSouth's DCS System and supported by BellSouth's network management software, DCS shall provide multipoint bridging of multiple channels to other DCSs. AT&T may designate multipoint bridging to be one-way broadcast from a single

UB  
FL6/10/97



Master to multiple tributaries, or two-way broadcast between a single Master and multiple tributaries.

10.6.19 Where technically available in BellSouth's DCS System and supported by BellSouth's network management software, DCS shall multiplex lower speed channels onto a higher speed interface and demultiplex higher speed channels onto lower speed interfaces as designated by AT&T

10.6.20 Where technically available in BellSouth's DCS System and supported by BellSouth's network management software, DCS shall perform signaling conversion and data conditioning as designated by AT&T. Such functions shall comply, at a minimum, with AT&T Technical Reference TR 62421 ACCUNET<sup>®</sup> Spectrum of Digital Services, December 1989 and AT&T Technical Reference TR 62310 DS0 Digital Local Channel Description and Interface Specification, August 1993, including current addendums.

#### 10.7 DCS Interface Requirements

10.7.1 Where technically available in BellSouth's DCS System and supported by BellSouth's network management software, BellSouth shall provide physical interfaces on DS0, DS1, and VT1.5 channel cross-connect devices at the DS1 rate or higher. In all such cases, these interfaces shall be in compliance with applicable Bellcore, ANSI, ITU, and AT&T standards.

10.7.2 Where technically available in BellSouth's DCS System and supported by BellSouth's network management software, BellSouth shall provide physical interfaces on DS3 channel cross-connect devices at the DS3 rate or higher. In all such cases, these interfaces shall be in compliance with applicable Bellcore, ANSI, ITU, and AT&T standards.

10.7.3 Where technically available in BellSouth's DCS System and supported by BellSouth's network management software, BellSouth shall provide physical interfaces on STS-1 cross-connect devices at the OC-3 rate or higher. In all such cases, these interfaces shall be in compliance with applicable Bellcore, ANSI, ITU, and AT&T standards.

10.7.4 Where technically available in BellSouth's DCS System and supported by BellSouth's network management software, Interfaces on all other cross-connect devices shall be in compliance with applicable Bellcore, ANSI, ITU, and AT&T standards.

10.8 DCS shall, at a minimum, meet all the requirements set forth in the following technical references:

*MB*  
FL6/10/97

- 10.8.1 DELETED
- 10.8.2 AT&T Data Communications Technical Reference TR 62310 DSO Digital Local Channel Description and Interface Specification, August 1993, and all addendums, where the underlying equipment used by BellSouth to provide DCS supports this functionality;
- 10.8.3 AT&T Technical Reference TR 62415 Access Specification For High Capacity (DS1/DS3) Dedicated Digital Service, June 1989, and all addendums including TR 62415A3 July, 1992, where the underlying equipment used by BellSouth to provide DCS supports this functionality
- 10.8.4 AT&T Technical Reference TR 62411 ACCUNET® T1.5 Service Description And Interface Specification, December 1990 and all addendums including Addendum 2, October 1992;
- 10.8.5 AT&T Technical Reference TR 54014 ACCUNET® T45 and T45 Reserved Services - Service Description And Interface Specification;
- 10.8.6 AT&T Technical Reference TR 54018 OC-3 Optical Interface Specifications, November 1991;
- 10.8.7 AT&T Technical Reference TR 54016 Requirements For Interfacing Digital Terminal Equipment To Services Employing The Extended Superframe Format, September 1989, where the underlying equipment used by BellSouth to provide DCS supports this functionality;
- 10.8.8 ANSI T1.102-1993, American National Standard for Telecommunications - Digital Hierarchy - Electrical Interfaces;
- 10.8.9 ANSI T1.102.01-199x, American National Standard for Telecommunications - Digital Hierarchy - VT1.5;
- 10.8.10 ANSI T1.105-1995, American National Standard for Telecommunications - Synchronous Optical Network (SONET) - Basic Description including Multiplex Structure, Rates and Formats;
- 10.8.11 ANSI T1.105.03-1994, American National Standard for Telecommunications - Synchronous Optical Network (SONET) - Jitter at Network Interfaces;
- 10.8.12 ANSI T1.105.03a-1995, American National Standard for Telecommunications - Synchronous Optical Network (SONET): Jitter at Network Interfaces - DS1 Supplement;

UB  
FL6/10/97

- 10.8.13 ANSI T1.105-06-199x, American National Standard for Telecommunications - Synchronous Optical Network (SONET) - Physical Layer Specifications;
- 10.8.14 ANSI T1.106-1988, American National Standard for Telecommunications - Digital Hierarchy - Optical Interface Specifications (Single Mode);
- 10.8.15 ANSI T1.107-1988, American National Standard for Telecommunications - Digital Hierarchy - Formats Specifications;
- 10.8.16 ANSI T1.107a-1990 - American National Standard for Telecommunications - Digital Hierarchy - Supplement to Formats Specifications (DS3 Format Applications);
- 10.8.17 ANSI T1.107b-1991 - American National Standard for Telecommunications - Digital Hierarchy - Supplement to Formats Specifications;
- 10.8.18 ANSI T1.117-1991, American National Standard for Telecommunications - Digital Hierarchy - Optical Interface Specifications (SONET) (Single Mode - Short Reach);
- 10.8.19 ANSI T1.403-1989, Carrier to Customer Installation, DS1 Metallic Interface Specification;
- 10.8.20 ANSI T1.404-1994, Network-to-Customer Installation - DS3 Metallic Interface Specification;
- 10.8.21 ITU Recommendation G.707, Network node interface for the synchronous digital hierarchy (SDH);
- 10.8.22 ITU Recommendation G.704, Synchronous frame structures used at 1544, 6312, 2048, 8488 and 44736 kbit/s hierarchical levels;
- 10.8.23 FR-440 and TR-NWT-000499, Transport Systems Generic Requirements (TSGR): Common Requirements;
- 10.8.24 GR-820-CORE, Generic Transmission Surveillance: DS1 & DS3 Performance;
- 10.8.25 GR-253-CORE, Synchronous Optical Network Systems (SONET): Common Generic Criteria; and
- 10.8.26 TR-NWT-000776, Network Interface Description for ISDN Customer Access.

UB

FL6/10/97

11 Signaling Link Transport

11.1 **Definition**

Signaling Link Transport is a set of two or four dedicated 56 Kbps transmission paths between AT&T-designated Signaling Points of Interconnection (SPOI) that provides appropriate physical diversity

11.2 **Technical Requirements**

11.2.1 Signaling Link Transport shall consist of full duplex mode 56 kbps transmission paths.

11.2.2 Of the various options available, Signaling Link Transport shall perform in the following two ways:

11.2.2.1 As an "A-link" which is a connection between a switch or SCP and a home Signaling Transfer Point Switch (STPS) pair; and

11.2.2.2 As a "D-link" which is a connection between two STPS pairs in different company networks (e.g., between two STPS pairs for two Competitive Local Exchange Carriers (CLECs)).

11.2.3 Signaling Link Transport shall consist of two or more signaling link layers as follows:

11.2.3.1 An A-link layer shall consist of two links.

11.2.3.2 A D-link layer shall consist of four links.

11.2.4 A signaling link layer shall satisfy a performance objective such that:

11.2.4.1 There shall be no more than two minutes down time per year for an A-link layer; and

11.2.4.2 There shall be negligible (less than 2 seconds) down time per year for a D-link layer.

11.2.5 A signaling link layer shall satisfy interoffice and intraoffice diversity of facilities and equipment, such that:

11.2.5.1 No single failure of facilities or equipment causes the failure of both links in an A-link layer (i.e., the links should be provided on a minimum of two separate physical paths end-to-end); and

*JB*  
FL6/10/97

11.2.5.2 No two concurrent failures of facilities or equipment shall cause the failure of all four links in a D-link layer (i.e., the links should be provided on a minimum of three separate physical paths end-to-end)

11.3 **Interface Requirements**

11.3.1 There shall be a DS1 (1.544 Mbps) interface at the AT&T-designated SPOIs. Each 56 kbps transmission path shall appear as a DS0 channel within the DS1 interface.

12. **Signaling Transfer Points (STPs)**

12.1 **Definition - Signaling Transfer Points** is a signaling network function that includes all of the capabilities provided by the signaling transfer point switches (STPSs) and their associated signaling links which enable the exchange of SS7 messages among and between switching elements, database elements and signaling transfer point switches. Figure 4 depicts Signaling Transfer Points.

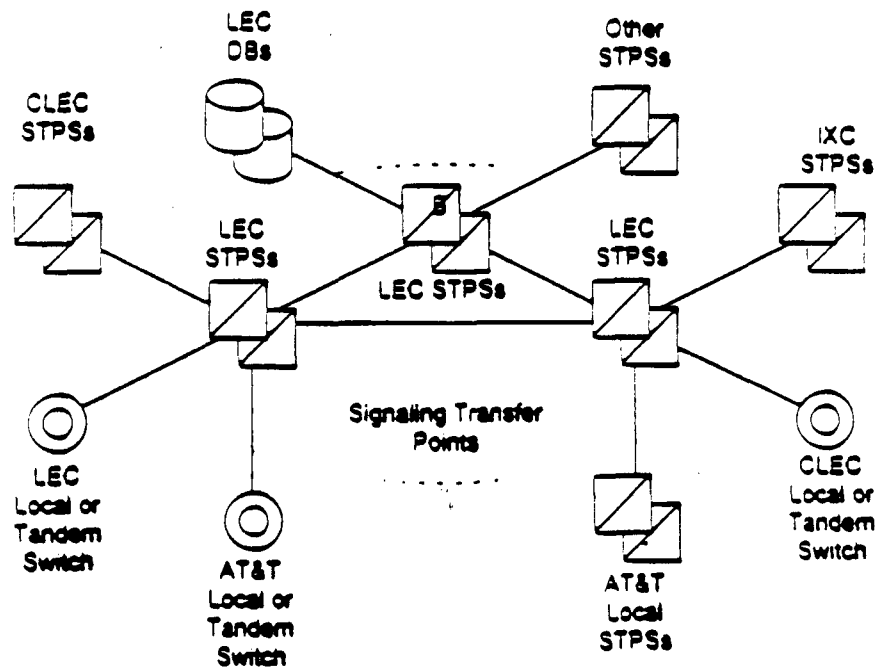

Figure 4

12.2 **Technical Requirements**

12.2.1 STPs shall provide access to Network Elements connected to BellSouth SS7 network. These include:

12.2.1.1 BellSouth Local Switching or Tandem Switching;

*UB*  
FL6/10/97

- 12.2.1.2 BellSouth Service Control Points/DataBases.
- 12.2.1.3 Third-party local or tandem switching
- 12.2.1.4 Third-party-provided STPs.
- 12.2.2 The connectivity provided by STPs shall fully support the functions of all other Network Elements connected to BellSouth SS7 network. This explicitly includes the use of BellSouth SS7 network to convey messages which neither originate nor terminate at a signaling end point directly connected to BellSouth SS7 network (i.e., transient messages). When BellSouth SS7 network is used to convey transient messages, there shall be no alteration of the Integrated Services Digital Network User Part (ISDNUP) or Transaction Capabilities Application Part (TCAP) user data that constitutes the content of the message.
- 12.2.3 If a BellSouth tandem switch routes calling traffic, based on dialed or translated digits, on SS7 trunks between an AT&T local switch and third party local switch, BellSouth SS7 network shall convey the TCAP messages that are necessary to provide Call Management features (Automatic Callback, Automatic Recall, and Screening List Editing) between the AT&T local STPs and the STPs that provide connectivity with the third party local switch, even if the third party local switch is not directly connected to BellSouth STPs.
- 12.2.4 STPs shall provide all functions of the MTP as defined in Bellcore ANSI Interconnection Requirements. This includes:
  - 12.2.4.1 Signaling Data Link functions, as defined in Bellcore ANSI Interconnection Requirements.
  - 12.2.4.2 Signaling Link functions, as defined in Bellcore ANSI Interconnection Requirements, and
  - 12.2.4.3 Signaling Network Management functions, as defined in Bellcore ANSI Interconnection Requirements.
- 12.2.5 STPs shall provide all functions of the SCCP necessary for Class 0 (basic connectionless) service, as defined in Bellcore ANSI Interconnection Requirements. In particular, this includes Global Title Translation (GTT) and SCCP Management procedures, as specified in T1.112.4. In cases where the destination signaling point is a BellSouth local or tandem switching system or data base, or is an AT&T or third party local or tandem switching system directly connected to BellSouth SS7 network, STPs shall perform final GTT of messages to the destination and SCCP Subsystem Management of the destination. In all

UB  
FL6/10/97

other cases. STPs shall perform intermediate GTT of messages to a gateway pair of STPSs in an SS7 network connected with BellSouth SS7 network, and shall not perform SCCP Subsystem Management of the destination.

- 12.2.5 STPs shall also provide the capability to route SCCP messages based on ISNI, as defined in Bellcore ANSI Interconnection Requirements, when this capability becomes available on BellSouth STPSs.
- 12.2.7 STPs shall provide on a non-discriminatory basis all functions of the OMAP commonly provided by STPSs, as specified in the reference in Section 10.4.5 of this Attachment. All OMAP functions will be on a "where available" basis and can include:
  - 12.2.7.1 MTP Routing Verification Test (MRVT) and
  - 12.2.7.2 SCCP Routing Verification Test (SRVT).
- 12.2.8 In cases where the destination signaling point is a BellSouth local or tandem switching system or database, or is an AT&T or third party local or tandem switching system directly connected to the BellSouth SS7 network, STPs shall perform MRVT and SRVT to the destination signaling point. In all other cases, STPs shall perform MRVT and SRVT to a gateway pair of STPSs in an SS7 network connected with the BellSouth SS7 network. This requirement shall be superseded by the specifications for Internetwork MRVT and SRVT if and when these become approved ANSI standards and available capabilities of BellSouth STPSs, and if mutually agreed upon by AT&T and BellSouth.
- 12.2.9 STPs shall be equal to or better than the following performance requirements:
  - 12.2.9.1 MTP Performance, as defined in Bellcore ANSI Interconnection Requirements and
  - 12.2.9.2 SCCP Performance, as defined in Bellcore ANSI Interconnection Requirements.
- 12.2.10 **SS7 Advanced Intelligent Network (AIN) Access**
  - 12.2.10.1 SS7 AIN Access shall provide the AT&T SCP access to BellSouth local switch via interconnection of BellSouth SS7 and AT&T SS7 Networks. BellSouth shall offer SS7 access through its STPs. BellSouth may utilize a mediation device on any part of its network, as necessary.
    - 12.2.10.1.1 **DELETED**

  
FL6/10/97

12.2.10.2

SS7 AIN Access is the provisioning of AIN triggers in a BellSouth local switch and interconnection of the BellSouth SS7 network with the AT&T SS7 network to exchange TCAP queries and responses with an AT&T SCP. See Figure 5 below.

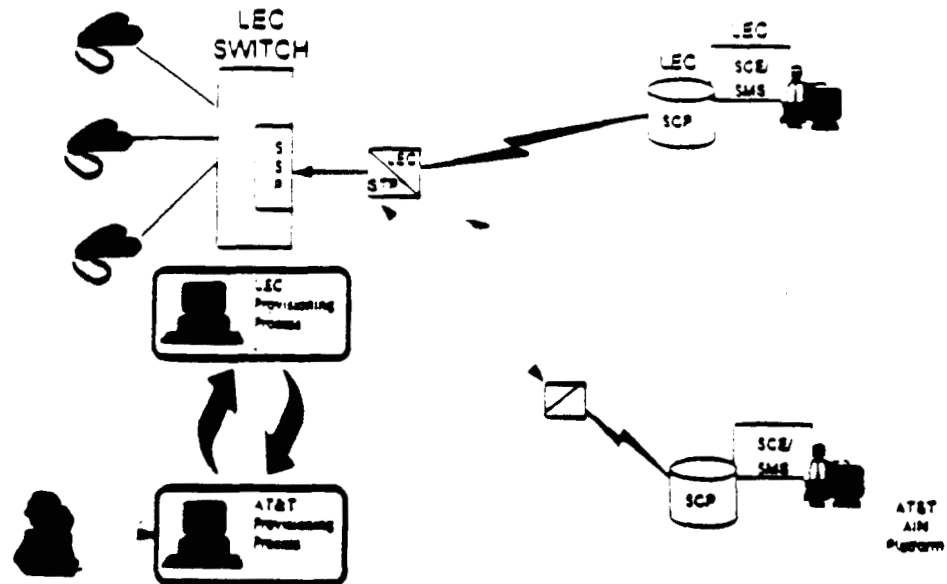

Figure 5

- 12.2.10.3 Physical interconnection between the BellSouth SS7 and the AT&T SS7 networks shall be through facilities and protocols as specified in the SS7 Network Interconnection section of this Agreement.
- 12.2.10.4 Reliability of interconnection shall be consistent with requirements for diversity and survivability as specified in the SS7 Network Interconnection section of this Agreement.
- 12.2.10.5 Delay associated with BellSouth local switch queries to the AT&T STP shall be equal to or shorter than the delay associated with queries to BellSouth STP.
- 12.2.10.6 BellSouth's STP's shall maintain global title translations necessary to direct AIN queries for select global title address and translation type values to the AT&T SS7 network.

*UB*  
FL6/10/97



- 12.2.10.7 BellSouth STPs shall route mutually agreeable AIN responses from the AT&T SCP via SS7 network interconnect to the local switch designated in the Signaling Connection Control Part (SCCP) called party address.
- 12.2.10.8 Network management controls resulting from an overload in elements not supporting AT&T customers shall not affect queries to AT&T SCPs.
- 12.2.10.9 Requirements for billing and recording information to track AIN query-response usage shall be consistent with Connectivity Billing and Recording requirements as specified in Attachment 6 (e.g., recorded message format and content, timeliness of feed, data format and transmission medium).
- 12.2.10.10 BellSouth shall provide to AT&T all necessary testing resources and staff to perform SS7 certification testing prior to interconnection in accordance with the Cooperative Testing section of this Agreement.
- 12.2.10.11 When AT&T selects SS7 AIN Access, BellSouth will provide access to provisioning processes to support interconnection of AT&T's STPs.
- 12.2.10.12 When AT&T selects SS7 AIN Access, BellSouth will provide interconnection of its SS7 network with BellSouth SS7 network for exchange of AIN TCAP messages as described in Section 12.2.10.13.2 below.
- 12.2.10.13 STPs shall offer SS7 AIN Access in accordance with the requirements of the following technical references, as implemented in BellSouth's STPs:
- 12.2.10.13.1 GR-2863-CORE, CCS Network Interface Specification Supporting Advanced Intelligent Network (AIN); and
- 12.2.10.13.2 GR-2902-CORE, CCS Network Interface Specification (CCSNIS) Supporting Toll-Free Service Using Advanced Intelligent Network (AIN).
- 12.3 **Interface Requirements**
- 12.3.1 BellSouth shall provide the following STPs options to connect AT&T or AT&T-designated local switching systems or STPs to BellSouth SS7 network:
- 12.3.1.1 An A-link interface from AT&T local switching systems; and,
- 12.3.1.2 A D-link interface from AT&T local STPs.
- 12.3.2 Each type of interface shall be provided by one or more sets (layers) of signaling links, as follows:

12.3.2.1

An A-link layer shall consist of two links, as depicted in Figure 6.

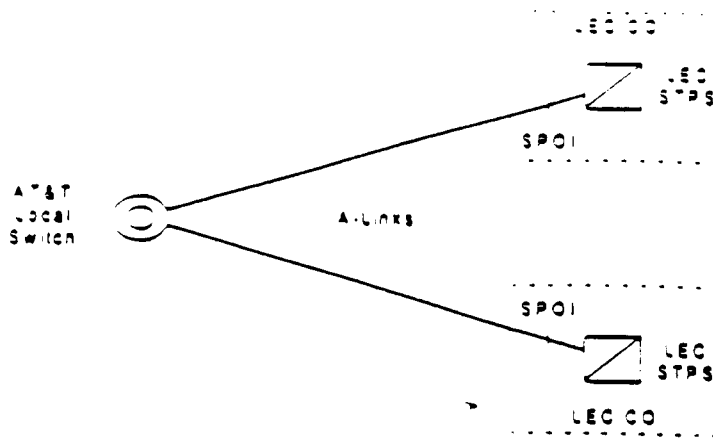

Figure 6. A-Link Interface

12.3.2.2

A D-link layer shall consist of four links, as depicted in Figure 7.

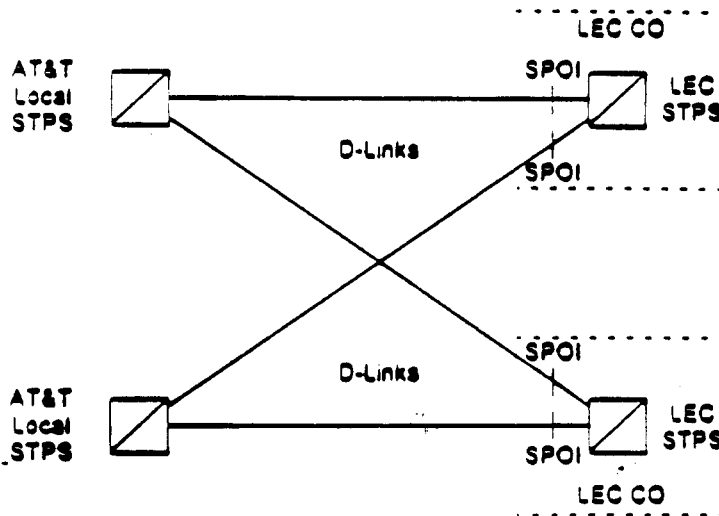

Figure 7. D-Link Interface

12.3.3

The Signaling Point of Interconnection (SPOI) for each link shall be located at a cross-connect element, such as a DSX-1, in the Central Office (CO) where BellSouth STPS is located. There shall be a DS1 or higher rate transport interface at each of the SPOIs. Each signaling link shall appear as a DS0 channel within the DS1 or higher rate interface. BellSouth shall offer higher rate DS1 signaling for interconnecting AT&T

*MB*  
FL6/10/97

local switching systems or STPSs with BellSouth STPSs as soon as these become approved ANSI standards and available capabilities of BellSouth STPSs. BellSouth and AT&T will work jointly to establish mutually acceptable SPOIs.

- 12.3.4 BellSouth CO shall provide intraoffice diversity between the SPOIs and BellSouth STPS, so that no single failure of intraoffice facilities or equipment shall cause the failure of both D-links in a layer connecting to a BellSouth STPS. BellSouth and AT&T will work jointly to establish mutually acceptable SPOIs.
- 12.3.5 BellSouth shall provide MTP and SCCP protocol interfaces that shall conform to all sections relevant to the MTP or SCCP in the following specifications:
  - 12.3.5.1 Bellcore GR-905-CORE, Common Channel Signaling Network Interface Specification (CCSNIS) Supporting Network Interconnection, Message Transfer Part (MTP), and Integrated Services Digital Network User Part (ISDNUP);
  - 12.3.5.2 Bellcore GR-1432-CORE, CCS Network Interface Specification (CCSNIS) Supporting Signaling Connection Control Part (SCCP) and Transaction Capabilities Application Part (TCAP).
- 12.3.6 **Message Screening**
  - 12.3.6.1 BellSouth shall set message screening parameters so as to accept valid messages from AT&T local or tandem switching systems destined to any signaling point within BellSouth's SS7 network where the AT&T switching system has a legitimate signaling relation.
  - 12.3.6.2 BellSouth shall set message screening parameters so as to pass valid messages from AT&T local or tandem switching systems destined to any signaling point or network accessed through BellSouth's SS7 network where the AT&T switching system has a legitimate signaling relation.
  - 12.3.6.3 BellSouth shall set message screening parameters so as to accept and pass/send valid messages destined to and from AT&T from any signaling point or network interconnected through BellSouth's SS7 network where the AT&T SCP has a legitimate signaling relation.
- 12.4 STPs shall be equal to or better than all of the requirements for STPs set forth in the following technical references:
  - 12.4.1 ANSI T1.111-1992 American National Standard for Telecommunications - Signaling System Number 7 (SS7) - Message Transfer Part (MTP);

- 12.4.2 ANSI T1.111A-1994 American National Standard for Telecommunications - Signaling System Number 7 (SS7) - Message Transfer Part (MTP) Supplement;
- 12.4.3 ANSI T1.112-1992 American National Standard for Telecommunications - Signaling System Number 7 (SS7) - Signaling Connection Control Part (SCCP);
- 12.4.4 ANSI T1.115-1990 American National Standard for Telecommunications - Signaling System Number 7 (SS7) - Monitoring and Measurements for Networks;
- 12.4.5 ANSI T1.116-1990 American National Standard for Telecommunications - Signaling System Number 7 (SS7) - Operations, Maintenance and Administration Part (OMAP);
- 12.4.6 ANSI T1.118-1992 American National Standard for Telecommunications - Signaling System Number 7 (SS7) - Intermediate Signaling Network Identification (ISNI);
- 12.4.7 Bellcore GR-905-CORE, Common Channel Signaling Network Interface Specification (CCSNIS) Supporting Network Interconnection, Message Transfer Part (MTP), and Integrated Services Digital Network User Part (ISDNUP); and
- 12.4.8 Bellcore GR-1432-CORE, CCS Network Interface Specification (CCSNIS) Supporting Signaling Connection Control Part (SCCP) and Transaction Capabilities Application Part (TCAP).

13. **Service Control Points/DataBases**

13.1 **Definition**

13.1.1 **Databases are the Network Elements that provide the functionality for storage of, access to, and manipulation of information required to offer a particular service and/or capability. Databases include, but are not limited to: Local Number Portability, LIDB, Toll Free Number Database, Automatic Location Identification/Data Management System, access to Service Creation Environment and Service Management System (SCE/SMS) application databases and Directory Assistance.**

13.1.2 **A Service Control Point (SCP) is a specific type of Database functionality deployed in a Signaling System 7 (SS7) network that executes service application logic in response to SS7 queries sent to it by a switching system also connected to the SS7 network. Service Management**

Systems provide operational interfaces to allow for provisioning, administration and maintenance of subscriber data and service application data stored in SCPs

**13.2 Technical Requirements for SCPs/Databases**

Requirements for SCPs/Databases within this section address storage of information, access to information (e.g. signaling protocols, response times), and administration of information (e.g., provisioning, administration, and maintenance). All SCPs/Databases shall be provided to AT&T in accordance with the following requirements, except where such a requirement is superseded by specific requirements set forth in Subsections 13.3 through 13.7 of this Attachment:

- 13.2.1 BellSouth shall provide physical interconnection to SCPs through the SS7 network and protocols, as specified in Section 10 of this Attachment, with TCAP as the application layer protocol.
- 13.2.2 BellSouth shall provide physical interconnection to databases via industry standard interfaces and protocols (e.g. ISDN and X.25).
- 13.2.3 The reliability of interconnection options shall be consistent with requirements for diversity and survivability as specified in Section 10 of this Attachment (which applies to both SS7 and non-SS7 interfaces).
- 13.2.4 **Database Availability**  
Call processing databases shall have a maximum unscheduled availability of 30 minutes per year. Unavailability due to software and hardware upgrades shall be scheduled during minimal usage periods and only be undertaken upon proper notification to providers which might be impacted. Any downtime associated with the provision of call processing related databases will impact all service providers, including BellSouth, equally.
- 13.2.5 BellSouth shall provide Database provisioning consistent with the provisioning requirements of this Agreement (e.g., data required, edits, acknowledgments, data format and transmission medium and notification of order completion).
- 13.2.6 The operational interface provided by BellSouth shall complete Database transactions (i.e., add, modify, delete) for AT&T customer records stored in BellSouth databases within 24 hours, or sooner where BellSouth provisions its own customer records within a shorter interval.



- 13.2.7 BellSouth shall provide Database maintenance consistent with the Maintenance requirements as specified in this Agreement (e.g. notification of BellSouth Network Affecting Events, testing, dispatch schedule and measurement and exception reports).
- 13.2.8 BellSouth shall provide billing and recording information to track database usage consistent with connectivity billing and recording requirements as specified in this Agreement (e.g., recorded message format and content, timeliness of feed, data format and transmission medium).
- 13.2.9 BellSouth shall provide SCPs/Databases in accordance with the physical security requirements specified in this Agreement.
- 13.2.10 BellSouth shall provide SCPs/Databases in accordance with the logical security requirements specified in this Agreement.

**13.3 Local Number Portability Database**

**13.3.1 Definition**

The Permanent Number Portability (PNP) database supplies routing numbers for calls involving numbers that have been ported from one local service provider to another. PNP is currently being worked in industry forums. The results of these forums will dictate the industry direction of PNP. BellSouth agrees to provide the PNP database as directed by the FCC and the Florida Public Service Commission.

**13.3.2 DELETED**

**13.3.3 DELETED**

**13.4 Line Information Database (LIDB):**

This Subsection 13.4 defines and sets forth additional requirements for the Line Information Database. This Subsection 13.4 supplements the requirements of Subsection 13.2 and 13.8 of this Attachment. AT&T acknowledges that BellSouth will store in its LIDB only records relating to service in the BellSouth region.

**13.4.1 Definition**

The Line Information Database (LIDB) is a transaction-oriented database accessible through Common Channel Signaling (CCS) networks. It contains records associated with customer Line Numbers and Special Billing Numbers (in accordance with the requirements in the technical reference in Section 13.8.5 of this Attachment). LIDB accepts queries from other Network Elements and provides appropriate responses. The

  
FL6/10/97

query originator need not be the owner of LIDB data. LIDB queries include functions such as screening billed numbers that provides the ability to accept Collect or Third Number Billing calls and validation of Telephone Line Number based non-proprietary calling cards. The interface for the LIDB functionality is the interface between BellSouth CCS network and other CCS networks. LIDB also interfaces to administrative systems. The administrative system interface provides AT&T Work Centers with an interface to LIDB for functions such as provisioning, auditing of data, access to LIDB measurements and reports.

**13.4.2 Technical Requirements:**

AT&T LIDB technical requirements are set forth below. BellSouth also will offer to AT&T any additional capabilities that are developed for LIDB during the life of this Agreement.

- 13.4.2.1** Prior to the availability of a long-term solution for Local Number Portability, BellSouth shall enable AT&T to store in BellSouth's LIDB any customer Line Number or Special Billing Number record, (in accordance with the technical reference in Section 13.8.5 of this Attachment) whether ported or not, for which the non-AT&T dedicated NPA-NXX or RAO-0/1XX Group is supported by that LIDB, except for numbers ported from a third party local services provider.
- 13.4.2.2** Prior to the availability of a long-term solution for Local Number Portability, BellSouth shall enable AT&T to store in BellSouth's LIDB any customer Line Number or Special Billing Number (in accordance with the technical reference in Section 13.8.5) record, whether ported or not, and AT&T dedicated NPA-NXX or RAO-0/1XX Group Records, except for numbers ported from a third party local services provider.
- 13.4.2.3** Subsequent to the availability of a long-term solution for Local Number Portability, BellSouth shall enable AT&T to store in BellSouth's LIDB any customer Line Number or Special Billing Number (in accordance with the technical reference in Section 13.8.5) record, whether ported or not, regardless of the number's dedicated NPA-NXX or RAO(NXX)-0/1XX., except for numbers ported from a third party local services provider.
- 13.4.2.4** BellSouth shall perform the following LIDB functions (i.e., processing of the following query types as defined in the technical reference in Section 13.8.5 of this Attachment) for AT&T's customer records in LIDB:
- 13.4.2.4.1** Billed Number Screening (provides information such as whether the Billed Number may accept Collect or Third Number Billing calls); and

  
FL6/10/97

- 13.4.2.4.2 Calling Card Validation: If AT&T chooses to offer Tel Line Number TLN and/or Special Billing Number (SBN) credit cards, calling card validation will be supported for the AT&T customer data in the LIDB.
- 13.4.2.5 BellSouth shall process AT&T's Customer records in LIDB at least at parity with BellSouth customer records, with respect to other LIDB functions (as defined in the technical reference in Section 13.8.5 of this Attachment). BellSouth shall indicate to AT&T what additional functions (if any) are performed by LIDB in the BellSouth network.
- 13.4.2.6 Within two (2) weeks after a request by AT&T, BellSouth shall provide AT&T with a list of the customer data items which AT&T would have to provide in order to support each required LIDB function. The list shall indicate which data items are essential to LIDB function, and which are required only to support certain services. For each data item, the list shall show the data formats, the acceptable values of the data item and the meaning of those values.
- 13.4.2.7 BellSouth shall provide LIDB systems for which operating deficiencies that would result in calls being blocked, shall not exceed 30 minutes per year.
- 13.4.2.8 BellSouth shall provide LIDB systems for which operating deficiencies that would not result in calls being blocked shall not exceed 12 hours per year.
- 13.4.2.9 BellSouth shall provide LIDB systems for which the LIDB function shall be in overload (degraded performance in accordance with the technical reference in Section 13.8.5 of this Attachment) no more than 12 hours per year. Such deficiency period is in addition to the periods specified in Sections 13.4.2.7 and 13.4.2.8 above.
- 13.4.2.10 BellSouth shall provide AT&T with the capability to provision (e.g., to add, update, and delete) NPA-NXX and RAO-0/1XX Group Records, and Line Number and Special Billing Number Records, associated with AT&T customers, directly into the BellSouth's LIDB provisioning process. The capability to provision (e.g., to add, update, and delete) NPA-NXX and RAO-01/1XX Group records, and Line Number and Special Billing Number Records, associated with AT&T customers will be provided by BellSouth's DBAC. Direct access into BellSouth's LIDB process is not currently available. Once Direct access becomes available with the appropriate security measures, BellSouth will offer such access to AT&T. In the interim, BellSouth will provide access by electronic mail, facsimile or password-protected phone call (applicable to Group level NPA-NXX and RAO-01/1XX; updated within the same day if notification to BellSouth is received by 1:00 PM central time).



- 13.4.2.11 BellSouth shall maintain customer data (for line numbers, card numbers and for any other types of data maintained in LIDB) so that such customers shall not experience any interruption of service due to the lack of such maintenance of customer data. In the event that end user customers change their local services provider, BellSouth will use its best efforts to minimize service interruption in those situations where BellSouth has control over additions and deletions to the database as the LIDB provider.
- 13.4.2.12 All additions, updates and deletions of AT&T data to the LIDB shall be solely at the direction of AT&T. Such direction from AT&T will not be required where the addition, update or deletion is necessary to perform standard fraud control measures (e.g., calling card auto-deactivation)
- 13.4.2.13 BellSouth shall provide priority updates to LIDB for AT&T data upon AT&T's request (e.g., to support fraud detection), via password-protected telephone card, facsimile, or electronic mail within one hour of notice from the established BellSouth contact.
- 13.4.2.14 BellSouth shall provide AT&T with the capability to directly obtain, through an electronic interface, reports of all AT&T data in LIDB. Such capability will be through the data migration format (FCIF Interface) that can be used to electronically obtain reports of AT&T data in LIDB.
- 13.4.2.15 BellSouth shall provide LIDB systems such that no more than 0.01% of AT&T customer records will be missing from LIDB, as measured by AT&T audits. BellSouth will audit AT&T records in LIDB against DBAS to identify record mis-matches and provide this data to a designated AT&T contact person to resolve the status of the records and BellSouth will update system appropriately. BellSouth will refer record of mis-matches to AT&T within one business day of audit. Once reconciled records are received back from AT&T, BellSouth will update LIDB the same business day if less than 500 records are received before 1:00PM Central Time. If more than 500 records are received, BellSouth will contact AT&T to negotiate a time frame for the updates, not to exceed three business days.
- 13.4.2.16 BellSouth shall perform backup and recovery of all of AT&T's data in LIDB including sending to LIDB all changes made since the date of the most recent backup copy, in at least the same time frame BellSouth performs backup and recovery of BellSouth data in LIDB for itself. Currently, BellSouth performs backups of the LIDB for itself on a weekly basis and when a new software release is scheduled, a backup is performed prior to loading the new release.

13.4.2.17

BellSouth shall provide to AT&T access to LIDB measurements and reports at least at parity with the capability that BellSouth has for its own customer records and that BellSouth provides to any other party. Electronic access shall be offered to AT&T when it becomes available. Currently, BellSouth provides the following information from the Billing Measurements System summarized by Data Owner/Query Originator:

- Calling Card Queries
- Billed Number Screening Queries
- Calling Card Successful
- Calling Card Denied
- Calling Card CCAN Service Denied
- Calling Card Pin Match Field
- Calling Card Record Not Found
- Billed Number Screening Successful
- Billed Number Screening Not Found
- Group Not Found
- BNS/C Processing Indicator Not Enabled
- Group Status/Nonparticipating

As additional LIDB measurements and reports become available, such measurements and reports also will be provided to AT&T.

13.4.2.18

BellSouth shall provide AT&T with LIDB reports of data which are missing or contain errors, as well as any misroute errors, within a reasonable time period as negotiated between AT&T and BellSouth.

13.4.2.19

BellSouth shall prevent any access to or use of AT&T data in LIDB by BellSouth personnel that are outside of established administrative and fraud control personnel, or by any other party that is not authorized by AT&T in writing.

13.4.2.20

BellSouth shall provide AT&T performance of the LIDB Data Screening function, which allows a LIDB to completely or partially deny specific query originators access to LIDB data owned by specific data owners, (in accordance with the technical reference in Section 13.8.5 of this Attachment) for Customer Data that is part of an NPA-NXX or RAO-0/1XX wholly or partially owned by AT&T at least at parity with BellSouth Customer Data. BellSouth shall obtain from AT&T the screening information associated with LIDB Data Screening of AT&T data in accordance with this requirement. BellSouth currently does not have LIDB Data Screening capabilities. When such capability is available, BellSouth shall offer it to AT&T under the Bona Fide Request process identified in Section 1.1 of this Agreement.

*UB*  
FL6/10/97

- 13.4.2.21 BellSouth shall accept queries to LIDB associated with AT&T customer records, and shall return responses in accordance with the requirements of Section 13.8.5.
- 13.4.2.22 BellSouth shall provide mean processing time at the LIDB within 0.50 seconds under normal conditions as defined in the technical reference in Section 13.8.5 of this Attachment.
- 13.4.2.23 BellSouth shall provide processing time at the LIDB within 1 second for 99% of all messages under normal conditions as defined in the technical reference in Section 13.8.5 of this Attachment.
- 13.4.2.24 BellSouth shall provide 99.9 % of all LIDB queries in a round trip within 2 seconds as defined in the technical reference in Section 13.8.5.
- 13.4.3 **Interface Requirements**  
BellSouth shall offer LIDB in accordance with the requirements of this subsection 13.4.3.
- 13.4.3.1 The interface to LIDB shall be in accordance with the technical reference in Section 13.8.3 of this Attachment.
- 13.4.3.2 The CCS interface to LIDB shall be the standard interface described in Section 13.8.3 of this Attachment.
- 13.4.3.3 The LIDB Data Base interpretation of the ANSI-TCAP messages shall comply with the technical reference in Section 13.8.4 of this Attachment. Global Title Translation shall be maintained in the signaling network in order to support signaling network routing to the LIDB.
- 13.5 **Toll Free Number Database**  
The Toll Free Number Database is a SCP that provides functionality necessary for toll free (e.g., 800 and 888) number services by providing routing information and additional so-called vertical features during call set-up in response to queries from SSPs. This Subsection 13.5 supplements the requirements of Subsections 13.2 and 31.8 of this Agreement. BellSouth shall provide the Toll Free Number Database in accordance with the following:
- 13.5.1 **Technical Requirements**
- 13.5.1.1 BellSouth shall make BellSouth Toll Free Number Database available for AT&T to query with a toll-free number and originating information.

*UB*  
FL6/10/97

- 13.5.1.2 The Toll-Free Number Database shall return carrier identification and, where applicable, the queried toll-free number, translated numbers and instructions as it would in response to a query from a BellSouth switch.
- 13.5.1.3 The SCP shall also provide, at AT&T's option, such additional feature as described in SR-TSV-002275 (BOC Notes on BellSouth Networks, SR-TSV-002275, Issue 2, (Bellcore, April 1994)) as are available to BellSouth. These may include but are not limited to:
- 13.5.1.3.1 Network Management;
  - 13.5.1.3.2 Customer Sample Collection; and
  - 13.5.1.3.3 Service Maintenance.
- 13.5.2 **Interface Requirements**
- The signaling interface between the AT&T or other local switch and the Toll-Free Number database shall use the TCAP protocol as specified in the technical reference in Section 13.8.1 of this Attachment, together with the signaling network interface as specified in the technical reference in Sections 13.8.2 and 13.8.6 of this Agreement.
- 13.6 **Automatic Location Identification/Data Management System (ALI/DMS)**
- The ALI/DMS Database contains customer information (including name, address, telephone information, and sometimes special information from the local service provider or customer) used to determine to which Public Safety Answering Point (PSAP) to route the call. The ALI/DMS database is used to provide more routing flexibility for E911 calls than Basic 911. This Subsection 13.6 supplements the requirements of Subsections 13.8.2 and 13.8.6 of this Attachment. BellSouth shall provide the Emergency Services Database in accordance with the following:
- 13.6.1 **Technical Requirements**
    - 13.6.1.1 BellSouth shall offer AT&T a data link to the ALI/DMS database or permit AT&T to provide its own data link to the ALI/DMS database. BellSouth shall provide error reports from the ALI/DMS data base to AT&T immediately after AT&T inputs information into the ALI/DMS data base. Alternately, AT&T may utilize BellSouth, to enter customer information into the data base on a demand basis, and validate customer information on a demand basis.
    - 13.6.1.2 The ALI/DMS database shall contain the following customer information.

  
FLS/10/97

- 13.6.1.2.1 Name.
- 13.6.1.2.2 Address;
- 13.6.1.2.3 Telephone number; and
- 13.6.1.2.4 Other information as appropriate (e.g., whether a customer is blind or deaf or has another disability).
- 13.6.1.3 When the BellSouth is responsible for administering the ALI/DMS database in its entirety, ported number NXXs entries for the ported numbers should be maintained unless AT&T requests otherwise and shall be updated if AT&T requests, provided AT&T supplies BellSouth with the updates.
- 13.6.1.4 When Remote Call Forwarding (RCF) is used to provide number portability to the local customer and a remark or other appropriate field information is available in the database, the shadow or "forwarded-to" number and an indication that the number is ported shall be added to the customer record.
- 13.6.1.5 If BellSouth is responsible for configuring PSAP features (for cases when the PSAP or BellSouth supports an ISDN interface) it shall ensure that CLASS Automatic Recall (Call Return) is not used to call back to the ported number. Although BellSouth currently does not have ISDN interface, BellSouth agrees to comply with this requirement once ISDN interfaces are in place.
- 13.6.2 **Interface Requirements**
- The interface between the E911 Switch or Tandem and the ALI/DMS database for AT&T customers shall meet industry standards.
- 13.7 **Directory Assistance Database**
- BellSouth shall make its directory assistance database available to AT&T in order to allow AT&T to provide its customers with the same directory assistance services BellSouth provides to BellSouth customers. BellSouth shall provide AT&T with an initial feed via magnetic tape and daily update initially via magnetic tape and subsequently via an electronic gateway to be developed mutually by AT&T and BellSouth of customer address and number changes. Directory Assistance Services must provide both the ported and ALEC telephone numbers to the extent available in BellSouth's database assigned to a customer. Privacy indicators must be properly identified to assure the non-published numbers are accurately identified.

- 13.8 SCPs/Databases shall be equal to or better than all of the requirements for SCPs/Databases set forth in the following technical references
- 13.8.1 GR-246-CORE, Bell Communications Research Specification of Signaling System Number 7, ISSUE 1 (Bellcore, December 1991)
- 13.8.2 GR-1432-CORE, CCS Network Interface Specification (CCSNIS) Supporting Signaling Connection Control Part (SCCP) and Transaction Capabilities Application Part (TCAP). (Bellcore, March 1994);
- 13.8.3 GR-954-CORE, CCS Network Interface Specification (CCSNIS) Supporting Line Information Database (LIDB) Service 6, Issue 1, Rev. 1 (Bellcore, October 1995);
- 13.8.4 GR-1149-CORE, OSSGR Section 10: System Interfaces, Issue 1 (Bellcore, October 1995) (Replaces TR-NWT-001149);
- 13.8.5 GR-1158-CORE, OSSGR Section 22.3: Line Information Database 6, Issue (Bellcore, October 1995);
- 13.8.6 GR-1428-CORE, CCS Network Interface Specification (CCSNIS) Supporting Toll Free Service (Bellcore, May 1995); and
- 13.8.7 BOC Notes on BellSouth Networks, SR-TSV-002275, ISSUE 2, (Bellcore, April 1994).
- 13.9 Service Creation Environment and Service Management System (SCE/SMS) Advanced Intelligent Network (AIN) Access
- 13.9.1 BellSouth's Service Creation Environment and Service Management System (SCE/SMS) Advanced Intelligent Network (AIN) Access shall provide AT&T the capability that will allow AT&T and other third parties to create service applications in a BellSouth Service Creation Environment and deploy those applications in a BellSouth SMS to a BellSouth SCP. The third party service applications interact with AIN triggers provisioned on a BellSouth SSP. See Figure 8 below.

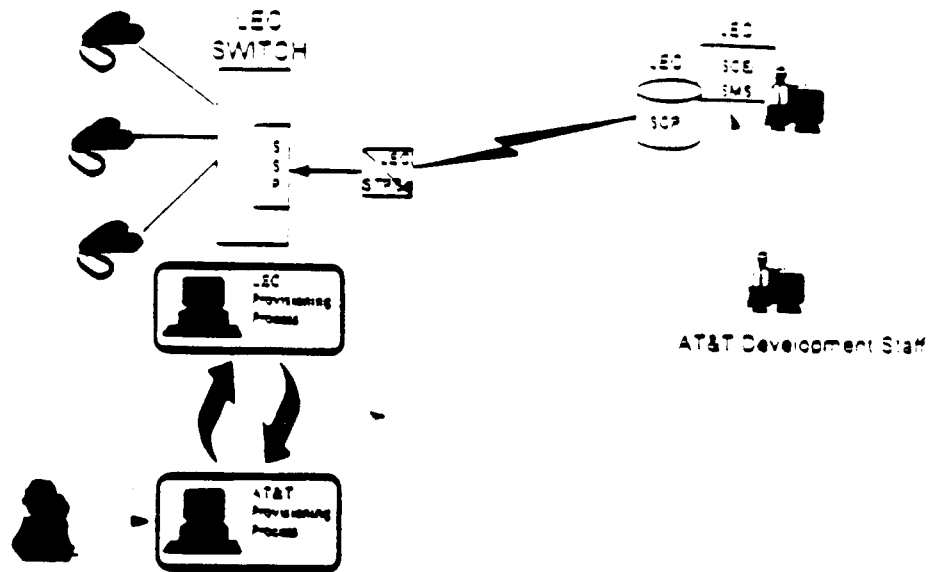

Figure 8

- 13.9.2 **BellSouth's SCE/SMS AIN Access shall provide access to SCE hardware, software, testing and technical support (e.g., help desk, system administrator) resources available to AT&T. Scheduling procedures shall provide AT&T equivalent priority to these resources**
- 13.9.3 **BellSouth's SCE/SMS AIN Access shall allow for multi-user access with proper source code management and other logical security functions as specified in the Security section of this Agreement.**
- 13.9.4 **BellSouth SCP shall partition and protect AT&T service logic and data from unauthorized access, execution or other types of compromise.**
- 13.9.5 **When AT&T selects SCE/SMS AIN Access, BellSouth shall provide training, documentation, and technical support to enable AT&T to use BellSouth's SCE/SMS AIN Access to create and administer applications. Training, documentation, and technical support will address use of SCE and SMS access and administrative functions, but will not include support for the creation of a specific service application.**
- 13.9.6 **When AT&T selects SCE/SMS AIN Access, BellSouth shall provide for a secure, controlled access environment in association with its internal use of AIN components. AT&T access will be provided via remote data connection (e.g., dial-in, ISDN).**

*UB*  
FL6/10/97

- 13.9.7 When AT&T selects SCE/SMS AIN Access, BellSouth shall allow AT&T to download data forms and/or tables to BellSouth SCP via BellSouth SMS without intervention from BellSouth (e.g., service customization and customer subscription).
- 13.9.8 **DELETED**
14. **Tandem Switching**
- 14.1 **Definition**
- Tandem Switching is the function that establishes a communications path between two switching offices through a third switching office (the tandem switch).
- 14.2 **Technical Requirements**
- 14.2.1 Tandem Switching shall have the same capabilities or equivalent capabilities as those described in Bell Communications Research TR-TSY-000540 Issue 2R2, Tandem Supplement, 6/1/90. The requirements for Tandem Switching include, but are not limited to the following:
- 14.2.1.1 Tandem Switching shall provide signaling to establish a tandem connection;
- 14.2.1.2 Tandem Switching will provide screening as jointly agreed to by AT&T and BellSouth;
- 14.2.1.3 **DELETED**
- 14.2.1.4 Tandem Switching shall provide Advanced Intelligent Network triggers supporting AIN features where such routing is not available from the originating end office switch, to the extent such Tandem switch has such capability
- 14.2.1.5 **DELETED**
- 14.2.1.6 Tandem Switching shall provide access to Toll Free number portability database as designated by AT&T;
- 14.2.1.7 Tandem Switching shall provide all trunk interconnections discussed under the "Network Interconnection" section (e.g., SS7, MF, DTMF, DialPulse, PRI-ISDN, DID, and CAMA-ANI (if appropriate for 911));

UB  
FL6/10/97



- 14.2.1.8 Tandem Switching shall provide connectivity to PSAPs where 911 solutions are deployed and the tandem is used for 911 and
- 14.2.1.9 Tandem Switching shall provide connectivity to transit traffic to and from other carriers.
- 14.2.2 Tandem Switching shall accept connections (including the necessary signaling and trunking interconnections) between end offices, other tandems, IECs, ICOs, CAPs and CLEC switches.
- 14.2.3 Tandem Switching shall provide local tandeming functionality between two end offices including two offices belonging to different CLECs (e.g. between an AT&T end office and the end office of another CLEC)
- 14.2.4 Tandem Switching shall preserve CLASS/LASS features and Caller ID as traffic is processed. Additional signaling information and requirements are provided in Section 10 of this Attachment.
- 14.2.5 Tandem Switching shall record billable events and send them to the area billing centers designated by AT&T. Tandem Switching will provide recording of all billable events as jointly agreed to by AT&T and BellSouth.
- 14.2.6 Upon a reasonable request from AT&T, BellSouth shall perform routine testing and fault isolation on the underlying switch that is providing Tandem Switching and all its interconnections. The results and reports of the testing shall be made immediately available to AT&T.
- 14.2.7 BellSouth shall maintain AT&T's trunks and interconnections associated with Tandem Switching at least at parity to its own trunks and interconnections.
- 14.2.8 **DELETED**
- 14.2.9 BellSouth shall control congestion points and network abnormalities. All traffic will be restricted in a non discriminatory manner.
- 14.2.10 Tandem Switching shall route calls to BellSouth or AT&T endpoints or platforms (e.g., operator services and PSAPs) on a per call basis as designated by AT&T, where such routing is not available from the originating end office switch, to the extent such Tandem Switch has such capability. Detailed primary and overflow routing plans for all interfaces available within BellSouth switching network shall be mutually agreed to by AT&T and BellSouth. Such plans shall meet AT&T requirements for routing calls through the local network.

- 14.2.11 Tandem Switching shall process originating toll-free traffic received from an AT&T local switch
- 14.2.12 In support of AIN triggers and features, Tandem Switching shall provide SSP capabilities when these capabilities are not available from the Local Switching Network Element, to the extent such Tandem Switch has such capability.
- 14.2.13 **DELETED**
- 14.3 **Interface Requirements**
  - 14.3.1 Tandem Switching shall provide interconnection to the E911 PSAP where the underlying Tandem is acting as the E911 Tandem.
  - 14.3.2 Tandem Switching shall interconnect, with direct trunks, to all carriers with which BellSouth interconnects.
  - 14.3.3 BellSouth shall provide all signaling necessary to provide Tandem Switching with no loss of feature functionality.
  - 14.3.4 Tandem Switching shall interconnect with AT&T's switch, using two-way trunks, for traffic that is transiting via BellSouth network to interLATA or intraLATA carriers. At AT&T's request, Tandem Switching shall record and keep records of traffic for billing.
  - 14.3.5 Tandem Switching shall provide an alternate final routing pattern for AT&T traffic overflowing from direct end office high usage trunk groups.
  - 14.3.6 **DELETED**
- 14.4 Tandem Switching shall meet or exceed (i.e., be more favorable to AT&T) each of the requirements for Tandem Switching set forth in the following technical references:
  - 14.4.1 Bell Communications Research TR-TSY-000540 Issue 2R2, Tandem Supplement, 8/1/90;
  - 14.4.2 GR-905-CORE covering CCSNIS;
  - 14.4.3 GR-1429-CORE for call management features; and GR-2863-CORE and GR-2902-CORE covering CCS AIN interconnection
- 15. **DARK FIBER - DELETED**
  - 15.1.1 **DELETED**

*MB*  
FL6/10/97

15.2 Requirements - DELETED

15.2.1 DELETED

15.2.2 DELETED

15.2.3 DELETED

15.2.4 DELETED

15.2.5 DELETED

15.3 DELETED

15.3.1 DELETED

15.3.2 DELETED

16. Additional Requirements

This Section 16 of Attachment 2 sets forth the additional requirements for unbundled Network Elements which BellSouth agrees to offer to AT&T under this Agreement.

16.1 Cooperative Testing

16.1.1 Definition

Cooperative Testing means that BellSouth shall cooperate with AT&T upon request or as needed to (1) ensure that the Network Elements and Ancillary Functions and additional requirements being provided to AT&T by BellSouth are in compliance with the requirements of this Agreement, and (2) test the overall functionality of various Network Elements and Ancillary Functions provided by BellSouth to AT&T in combination with each other or in combination with other equipment and facilities provided by AT&T or third parties, and (3) ensure that all operational interfaces and processes are in place and functioning properly and efficiently for the provisioning and maintenance of Network Elements and Ancillary Functions and so that all appropriate billing data can be provided to AT&T.

16.1.2 Requirements

BellSouth shall provide performance equal to or better than all of the requirements set forth in this Section 16.1.2. In addition, within ninety (90) days of the Effective Date of this Agreement, AT&T and BellSouth will agree upon a Cooperative Testing process which will include

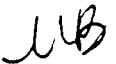
  
FL6/10/97

procedures for resolving technical issues relating to interconnection of AT&T's network to BellSouth's network and Network Elements and Ancillary Functions. The agreed upon process shall include procedures for escalating disputes and unresolved issues up through higher levels of each company's management. If AT&T and BellSouth do not reach agreement on such a process within ninety (90) days, any issues that have not been resolved by the parties with respect to such process shall be handled pursuant to the procedures identified in Section 16 of the General Terms and Conditions of this Agreement unless both parties agree to extend the time to reach agreement on such issues. The cooperative testing process shall address the following:

- 16.1.2.1 AT&T access for testing at any interface between a BellSouth Network Element or combinations and AT&T equipment or facilities. Such test access must be sufficient to ensure that the applicable requirements can be tested by AT&T seven (7) days per week, 24 hours per day.
- 16.1.2.2 Testing of any interfaces, Network Elements or Ancillary Functions and additional requirements provided by BellSouth pursuant to this Agreement.
- 16.1.2.3 Engineering data for the loop components as set forth in this Attachment which AT&T may desire to test. Such data shall include equipment engineering and cable specifications, signaling and transmission path data.
- 16.1.2.4 AT&T requests for office records, central office layout and design records and drawings, system engineering and other applicable documentation pertaining to a Network Element or Ancillary Function or the underlying equipment that is then providing a Network Element or Ancillary Function to AT&T.
- 16.1.2.5 AT&T requests for any applicable test results, from BellSouth testing activities on a Network Element or Ancillary Function or Additional Requirement or the underlying equipment providing a Network Element or Ancillary Function or Additional Requirements to AT&T. AT&T may review such testing results and may notify BellSouth of any deficiencies that are detected.
- 16.1.2.6 AT&T request for the temporary provision of selected Local Switching features for testing.
- 16.1.2.7 Technical staff to meet with AT&T representatives to provide required support for Cooperative Testing.

- 16.1.2.3 Dedicated Transport and Loop Feeder may experience alarm conditions due to in-progress tests. BellSouth shall not remove such facilities from service without obtaining AT&T's prior approval.
- 16.1.2.9 Tests or maintenance procedures on Network Elements or Ancillary Functions or on the underlying equipment that is then providing a Network Element or Ancillary Function, that may cause a service interruption or degradation if such tests and procedures are at a time that is mutually acceptable to AT&T and BellSouth.
- 16.1.2.10 A single point of contact to AT&T that is available 7 days per week, 24 hours per day for trouble status, sectionalization, resolution, escalation, and closure. Such staff shall be adequately skilled to allow expeditious problem resolution.
- 16.1.2.11 Electronic access to 105 responders, 100-type test lines, or 102-type test lines associated with any circuits under test.
- 16.1.2.12 BellSouth participation in Cooperative Testing with AT&T upon AT&T's request to test any operational interface or process used to provide Network Elements, Ancillary Functions or Services to AT&T.
- 16.1.2.13 Completing Cooperative Testing expeditiously.
- 16.1.2.14 Enhancements to BellSouth's provisioning processes to deliver Network Elements and Ancillary Functions and any Additional Requirements to AT&T in shorter intervals than during subsequent normal service periods.
- 16.1.2.15 BellSouth participation in Cooperative Testing requested by AT&T whenever it is deemed necessary by AT&T to insure service performance, reliability and customer serviceability.
- 16.1.2.16 Procedures to cover AT&T acceptance or rejection of a Network Element ordered by AT&T if upon completion of cooperative acceptance testing, the tested Network Element does not meet the requirements stated herein.

**16.2 Performance**

**16.2.1 Scope:**

This section addresses performance requirements for Network Elements and Ancillary Functions to provide local service. It includes requirements for the reliability and availability of Network Elements and Ancillary Functions, and quality parameters such as transmission quality (analog

*JB*  
FL6/10/97

and digital), and speed (or delay). In addition, an overview of service performance requirements is given.

- 16.2.1.1 The General Performance Requirements in this section apply to all aspects of Network Elements and Ancillary Functions. Additional requirements are given in this performance section and in the individual Network Elements sections.
- 16.2.2 BellSouth shall work cooperatively with AT&T to determine appropriate performance allocations across Network Elements.
- 16.2.3 BellSouth shall comply with the following technical documents to the extent that they are consistent with the greater of BellSouth's actual performance or applicable industry standards. If AT&T requests performance that exceeds either the industry standards or the actual performance that BellSouth provides to itself, then AT&T shall request such additional requirements through the Bona Fide Request process set forth in Section 1.1 of the General Terms and Conditions of this Agreement.
  - 16.2.3.1 **Bell Communications Research, Inc. Documents**
    - 16.2.3.1.1 *FR-64, LATA Switching Systems Generic Requirements (LSSGR)*. This document contains 117 Technical References and Generic Requirements. Sections provide the requirements for local switching systems (also referred to as end offices) that serve customers' lines. Some modules of the LSSGR are also referenced separately in this document.
    - 16.2.3.1.2 *TR-NWT-000499, Issue 5, Rev 1, April 1992, Transport Systems Generic Requirements (TSGR): Common Requirements.*
    - 16.2.3.1.3 *TR-NWT-000418, Issue 2, December 1992, Generic Reliability Assurance Requirements For Fiber Optic Transport Systems.*
    - 16.2.3.1.4 *TR-NWT-000057, Issue 2, January 1993, Functional Criteria for Digital Loop Carriers Systems.*
    - 16.2.3.1.5 *TR-NWT-000507, Issue 5, December 1993, LSSGR - Transmission, Section 7.*
    - 16.2.3.1.6 *GR-303-CORE, Issue 1, September 1995, Integrated Digital Loop Carrier System Generic Requirements, Objectives, and Interface.*
    - 16.2.3.1.7 *GR-334-CORE, Issue 1, June 1994, Switched Access Service: Transmission Parameter Limits and Interface Combinations.*

  
FL6/10/97

- 16.2.3.1.8 TR-NWT-000335, Issue 3, May 1993, *Voice Grade Special Access Services - Transmission Parameter Limits and Interface Combinations*
- 16.2.3.1.9 TR-TSY-000529, Issue 2, July 1987, *Public Safety - LSSGR*.
- 16.2.3.1.10 GR-1158-CORE, Issue 2, October 1995, *OSSGR Section 22.3: Line Information Database*.
- 16.2.3.1.11 TR-TSY-000511, Issue 2, July 1987, *Service Standards, a Module (Section 11) of LATA Switching Systems Generic Requirements (LSSGR, FR-NWT-000064)*.
- 16.2.3.1.12 TR-NWT-000393, January 1991, *Generic Requirements for ISDN Basic Access Digital Subscriber Lines.*
- 16.2.3.1.13 TR-NWT-000909, December 1991, *Generic Requirements and Objectives for Fiber In The Loop Systems.*
- 16.2.3.1.14 TR-NWT-000505, Issue 3, May 1991, *LSSGR Section 5, Call Processing.*
- 16.2.3.1.15 FR-NWT-000271, 1993, *Operator Services Systems Generic Requirements (OSSGR)*.
- 16.2.3.1.16 TR-NWT-001156, Issue 2, July 1993, *OSSGR Operator Services Systems Generic Requirements, Section 21, Operator Subsystem.*
- 16.2.3.1.17 SR-TSY-001171, Issue 1, January 1989, *Methods and Procedures for System Reliability Analysis.*
- 16.2.3.1.18 *Bellcore Telecommunications Transmission Engineering, 3rd Ed, 1990.*
- 16.2.3.2 **ANSI Standards**
- 16.2.3.2.1 ANSI T1.512-1994, *Network Performance - Point-to-Point Voice-Grade Special Access Network Voiceband Data Transmission Objectives.*
- 16.2.3.2.2 ANSI T1.508-1990, *Network Performance - Transmission Specifications for Switched Exchange Access Network.*
- 16.2.3.2.3 ANSI T1.508-1992, *Telecommunications - Network Performance - Loss Plan for Evolving Digital Networks. Also supplement T1.508a-1993.*
- 16.2.3.2.4 ANSI T1.101-1994, *Digital Synchronization Network Plan.*
- 16.2.3.3 **TIA/EIA Standards**

- 16.2.3.3.1 Requirements not specifically addressed here shall be found in the documents listed in Electronic Industries Association/Telecommunications Industries Association Standards and Engineering Publications.
- 16.2.3.3.2 TIA/EIA TSB-37A, Telephone Network Transmission Model for Evaluating Modem Performance.
- 16.2.3.3.3 TIA/EIA TSB-38, Test Procedure for Evaluation of 2-wire 4 kHz Voiceband Duplex Modems.
- 16.2.3.4 **IEEE Standards**
- 16.2.3.4.1 IEEE Standard 743-1984, IEEE Standard Methods and Equipment for Measuring Transmission Characteristics of Analog Voice Frequency Circuits.
- 16.2.3.4.2 ANSI/IEEE Standard 820-1984, Telephone Loop Performance Characteristics.
- 16.2.3.5 **AT&T Standards**
- 16.2.3.5.1 Outside Plant Engineering Handbook, August 1994.
- 16.2.3.5.2 AT&T Pub. 60220, Issue 1, April 1991, 5ESS OSPS Interface Technical Specification for Domestic Toll And Assistance Applications.
- 16.2.3.5.3 AT&T Technical Reference TR 43202, May 1985, AT&T Analog Voice Total and Coordinated Services.
- 16.2.3.5.4 AT&T Technical Reference TR 41458, April 1990, Special Access Connection to the AT&T Network.
- 16.2.3.5.5 AT&T Technical Reference TR 62415, June 1989, Access Specification For High Capacity (DS1/DS3) Dedicated Digital Service. Also TR 62415A2 November 1990, and TR 62415A3 July 1992 which are addendae to TR 62415.
- 16.2.3.5.6 AT&T Technical Reference TR 54016, September 1989, Requirements For Interfacing Digital Terminal Equipment To Services Employing The Extended Superframe Format.
- 16.2.3.5.7 AT&T Technical Reference TR 62411, December 1990, ACCUNET T1.5 Service Description And Interface Specification. Also Addendum 1 March 1991 and Addendum 2 October 1992.

  
FL6/10/97



- 16.2.3.5.8 AT&T Technical Reference TR 62421, December 1989, ACCUNET Spectrum of Digital Services Description And Interface Specification Also TR 62421A Addendum 2 November 1992.
- 16.2.3.5.9 AT&T Data Communications Technical Reference TR 62310, August 1993, DS0 Digital Local Channel Description And Interface Specification Also Addendum 2 November 1992.
- 16.2.3.5.10 AT&T Technical Reference TR 54014, 1992, ACCUNET T45 and T45 Reserved Services - Service Description And Interface Specification
- 16.2.3.5.11 AT&T Technical Reference TR 54018, most current issue, ACCUNET T155 Service Description And Interface Specification.

**16.2.4 Services and Capabilities**

- 16.2.4.1 All Network Elements shall provide performance sufficient, in combination with other Network Elements, to provide the following applications in accordance with the requirements of this document:
  - 16.2.4.1.1 Voice services.
  - 16.2.4.1.2 Voice-band data modem connections up to and including 28.8 kbps V.34.
  - 16.2.4.1.3 FAX transmissions up to and including 14.4 kbps group 3.
  - 16.2.4.1.4 CLASS/LASS features.
  - 16.2.4.1.5 Operator Systems.
- 16.2.4.2 Where available, the following capabilities shall be provided as applicable:
  - 16.2.4.2.1 ISDN BRI
  - 16.2.4.2.2 ISDN PRI
  - 16.2.4.2.3 Switched Digital Data
  - 16.2.4.2.4 Non-Switched Digital Data
  - 16.2.4.2.5 Types of Video applications
  - 16.2.4.2.6 Coin Services
  - 16.2.4.2.7 Frame Relay and ATM

16.2.4.2.3 Private Line Services

16.2.5 Specific Performance Requirements

BellSouth shall comply with the following performance requirements to the extent that they are consistent with the greater of BellSouth's actual performance or applicable industry standards. If AT&T requests performance requirements that exceed either the industry standards or the actual performance that BellSouth provides to itself, then AT&T shall request such performance through the Bona Fide Request process set forth in Section 1.1 of the General Terms and Conditions of this Agreement.

16.2.5.1 BellSouth shall provide performance equal to or better than all of the requirements set forth in this Section. Unless noted otherwise, requirements and objectives are given in terms of specific limits. This means that all tests (acceptance and ongoing performance) shall meet the limit(s) to satisfy the requirement.

16.2.5.2 **Performance Allocation** Transmission path impairments may be classified as either analog or digital, and will depend on the nature of the signal transmitted across the Network Element. Analog impairments are introduced on any analog portion of the loop, typically between the NID portion of Loop Distribution and the analog to digital (A/D) conversion, and are usually correlated with the length of the physical plant. Digital impairments are introduced by A/D conversion and by interfaces between digital Network Elements. In addition, noise can be introduced by either analog transmission or the A/D conversion.

16.2.5.3 **Loop Combination Architecture Constraints**

16.2.5.3.1 The following constraints will limit not only the variety of Loop Combination architectures that may be considered, but also the architectures BellSouth may consider to deliver any Ancillary Function or Network Element. These constraints apply to the entire path between the NID portion of Loop Distribution and BellSouth switch. Any exceptions to these restrictions shall be specifically requested or approved by AT&T in writing.

16.2.5.3.1.1 No more than 1 A-D conversion.

16.2.5.3.1.2 No more than 1, 2-to-4-wire hybrid.

16.2.5.3.1.3 No voice compression.

16.2.5.3.1.4 No echo cancelers or suppressers.

  
FL6/10/97

- 16.2.5.3.1.5 One digital loss pad per PBX.
- 16.2.5.3.1.6 No digital gain.
- 16.2.5.3.1.7 No additional equipment that might significantly increase intermodulation distortion.
- 16.2.5.4 **Transmission Impairments**
  - 16.2.5.4.1 **Analog Impairments** Analog impairments are those introduced on portions of the end-to-end circuit on which communications signals are transmitted in analog format. These portions of the transmission path would typically be between NID and an A/D conversion, most commonly on the metallic loop. The performance on the analog portion of a circuit is typically inversely proportional to the length of that circuit.
    - 16.2.5.4.1.1 **Loss**
      - 16.2.5.4.1.1.1 Electrical loss is measured using a 1004 Hz 0.0dB one Milliwatt 900 ohm test tone.
      - 16.2.5.4.1.1.2 Off-hook electrical loss between the NID and the switch shall be no more than 8.0 dB for any line, and the mean value for all lines shall be 3.5 dB  $\pm$ 0.5 dB. On-hook electrical loss between the NID and the switch shall be no more than 4.0 dB above the off-hook electrical loss for any line.
    - 16.2.5.4.1.2 **Idle Channel Circuit Noise**
      - 16.2.5.4.1.2.1 Idle channel circuit noise (C-message) is added by analog facilities, by the A/D conversion of signals, by digital processing equipment (e.g. echo cancelers, digital loss pads), robbed bit signaling, and errors on digital facilities.
      - 16.2.5.4.1.2.2 Idle channel circuit noise shall be less than or equal to 18 dBmC.
    - 16.2.5.4.1.3 **Talker Echo**
      - 16.2.5.4.1.3.1 The primary source of echo is improper impedance-matching at the 2-to-4 wire hybrid in BellSouth network. The impact on customer perception is a function of both echo return loss and delay.
      - 16.2.5.4.1.3.2 Echo Return Loss (ERL) shall be greater than 26dB to a standard termination (900 ohms, 2.16  $\mu$ Fd), and greater than 14 dB to a telephone set off-hook. Singing Return Loss (SRL) shall be greater than 21dB to a standard termination, and greater than 11 dB to a telephone set off-hook.

*UB*

**16.2.5.4.1.4 Listener Echo**

Listener echo is a double reflection of a transmitted signal at two different impedance mismatches in the end-to-end connection. While in extreme cases it can degrade voice transmission performance, listener echo is primarily an issue for voiceband data. The requirements on Talker Echo shall apply to Listener Echo.

**16.2.5.4.1.5 Propagation and Processing Delay**

**16.2.5.4.1.5.1** Propagation delay is the delay involved in transmitting information from one location to another. It is caused by processing delays of equipment in the network and delays associated with traveling across transmission facilities.

**16.2.5.4.1.5.2** BellSouth shall cooperate with AT&T to limit total service propagation and processing delay to levels at parity with that within the BellSouth local network.

**16.2.5.4.1.6 Signal-to-Noise Ratio**

**16.2.5.4.1.6.1** The Signal-to-Noise Ratio (S/N) is a critical parameter in determining voiceband data performance. It is typically measured with a 1004 Hz tone.

**16.2.5.4.1.6.2** BellSouth must provide on the Loop Combination a signal-to-noise ratio of at least 37 dB between the NID and the end office.

**16.2.5.4.1.7 C-Notched Noise**

The requirements for Signal-to-Noise Ratio shall apply to C-Notched Noise.

**16.2.5.4.1.8 Attenuation Distortion**

**16.2.5.4.1.8.1** Attenuation distortion, also known as frequency distortion or gain slope, measures the variations in loss at different frequencies across the voice frequency spectrum (200 Hz - 3400 Hz). It is measured by subtracting the loss at 1004 Hz from the loss at the frequency of interest.

**16.2.5.4.1.8.2** Attenuation distortion from the NID to the switch shall be within the range  $\pm 0.5$  dB for frequencies between 304 and 3004 Hz; from the switch to NID attenuation distortion shall be within the range  $\pm 0.5$  dB for frequencies between 204 Hz and 3004 Hz. In addition, attenuation distortion shall remain within the range  $+1$ dB/ $-3$ dB for frequencies between 200 Hz and 3500 Hz.

**16.2.5.4.1.9 Envelope Delay Distortion**

**16.2.5.4.1.9.1** Envelope Delay Distortion (EDD) measures the difference in transit time of signals at different frequencies. EDD is measured relative to the transit time of a 1704 Hz. tone, and is given in microseconds. EDD is used as an approximation of the group delay of the channel.

**16.2.5.4.1.9.2** EDD shall be: 1704 Hz to 604 Hz –  $\leq 350 \mu\text{sec.}$ ; 1704 Hz to 2804 Hz –  $\leq 195 \mu\text{sec.}$ ; 1704 Hz to 204 Hz –  $\leq 580 \mu\text{sec.}$ ; 1704 Hz to 3404 Hz –  $\leq 400 \mu\text{sec.}$

**16.2.5.4.1.10 Phase Jitter**

**16.2.5.4.1.10.1** Phase jitter measures the unwanted angular modulation of a signal. It is caused by noise or the actual modulation of the signal by another unwanted signal. It displaces the zero crossings of a signal. It is measured in terms of peak-to-peak deviations of a 1004 Hz. tone from its nominal zero crossings, and in a particular frequency band (20-300 Hz and either 4-300 Hz or 2-300 Hz). Phase jitter impacts voiceband data performance and can make modems more susceptible to other impairments, including noise.

**16.2.5.4.1.10.2** From the NID to the interexchange carrier point of termination, phase jitter shall be  $<1.5^\circ$  point-to-point in the 20-300 Hz band, and  $<1.8^\circ$  point-to-point in the 4-300 Hz. band.

**16.2.5.4.1.11 Amplitude Jitter**

**16.2.5.4.1.11.1** Amplitude jitter is any deviation of the peak value of a 1004 Hz signal from its nominal value. Excessive amounts can impair voiceband data performance. It is primarily caused by noise but can also be caused by phase jitter, gain hits, or single frequency interference.

**16.2.5.4.1.11.2** In NID-interexchange carrier point of termination,  $\leq 2.5\%$  of amplitude jitter is permitted in the 20-300 Hz band and  $\leq 2.9\%$  in the 4-300 Hz band.

**16.2.5.4.1.12 Intermodulation Distortion**

**16.2.5.4.1.12.1** Intermodulation distortion (IMD) measures non-linear distortions of a signal. It compares the power of harmonic tones to the power of the transmitted tones. It is measured for both the 2nd and 3rd harmonics of the transmitted tones. IMD is caused by compression or clipping and can impair voiceband data performance.

*UB*

16.2.5.4.1.12.2 Both 2nd and 3rd order IMD between the NID and end office must be  $\geq$  52dB.

16.2.5.4.1.13 **Impulse Noise**

16.2.5.4.1.13.1 Impulse noise is a sudden and large increase in noise on a channel for a short duration of time. Impulse noise is measured as a count of the number of times a noise threshold is exceeded during a given time period (typically 5 or 15 minutes). It is caused by protection switching, maintenance activities, electromechanical switching systems, digital transmission errors, and line coding mismatches. Impulse noise sounds like clicking noises or static on voice connections. Impulse noise impairs voiceband data performance.

16.2.5.4.1.13.2 The NID to interexchange carrier point of termination portions of connections shall introduce no impulse noise events within 6dB of the received signal power on 93% of all 15 minute connections. In addition, there shall be no more than 1 impulse noise event within 6 dB of the received signal power during any 30-minute period.

16.2.5.4.1.14 **Phase Hits**

16.2.5.4.1.14.1 Phase hits are a sudden change in the phase of a signal lasting at least 4 msec. Phase hits are measured using a threshold which indicates how much the phase of the signal has changed with respect to its nominal phase. Phase hits are caused by protection switching and slips or other synchronization errors. Phase hits can impair voiceband data performance.

16.2.5.4.1.14.2 Between the NID and interexchange carrier point of termination, 99.75% of all 15-minute connections shall have no phase hits exceeding 10°. In addition, there shall be no more than 1 phase hit exceeding 10° in any 30-minute period.

16.2.5.4.1.15 **Gain Hits**

16.2.5.4.1.15.1 Gain hits are sudden changes in the level of a signal that last at least 4 msec. Gain hits are measured against a threshold of typically 2-5 dB relative to the signal's nominal level. Gain hits are usually caused by protection switches and can impair voiceband data performance.

16.2.5.4.1.15.2 Between the NID and the interexchange carrier point of termination, 99.5% of all 15-minute connections shall have no gain hits exceeding 3 dB. In addition, there shall be no more than 1 gain hit exceeding 3 dB in any 30-minute period.

**16.2.5.4.1.16 Dropouts**

16.2.5.4.1.16.1 Dropouts are drops in the level of a signal of 12 dB or more for at least 4 msec. They are caused by protection switching events, radio fading, and conditions causing digital carrier systems to lose frame. Dropouts are critical for voiceband data performance but, if severe enough, will also affect voice quality.

16.2.5.4.1.16.2 Between the NID and the interexchange carrier point of termination, 99.9% of all 15-minute connections shall have no dropouts and in addition, no connection shall suffer more than 1 dropout in any 60-minute period.

**16.2.5.4.1.17 Frequency Shift**

16.2.5.4.1.17.1 Frequency shift measures any frequency changes that occur when a signal is transmitted across a channel. It is typically measured using a 1004 Hz tone. Frequency shift has very little impact on voice or voiceband data performance; however, round-trip frequency shifts can affect the ability of echo cancelers to remain converged.

16.2.5.4.1.17.2 No more than 0.2 Hz frequency shift shall be on any connection. In addition, 99.5% of all calls shall have frequency shift < 0.1 Hz.

**16.2.5.4.1.18 Crosstalk**

16.2.5.4.1.18.1 Crosstalk is the presence of signals from other telephone connections on a circuit. Crosstalk can be either intelligible, when speech from other connections can be heard and understood, or unintelligible. Crosstalk is caused by inter-channel interference on the transmission system. Crosstalk is difficult to measure: it requires correlating signals on different circuits or using human listeners to identify its presence. Trouble reports may be used to estimate the probability of crosstalk.

16.2.5.4.1.18.2 99% of Loop Combinations shall have probability  $\leq 0.1\%$  of experiencing crosstalk exceeding -65 dBm0.

**16.2.5.4.1.19 Clipping**

16.2.5.4.1.19.1 Clipping occurs when part of a transmitted signal is dropped and does not reach the receiving portion on a connection. It can be caused by Digital Speech Interpolation (DSI) equipment used in Digital Circuit Multiplication Systems (DCMS) which increase the amount of traffic that transmission facilities carry, and by echo cancelers or echo suppressers.

16.2.5.4.1.19.2 No clipping incidents shall occur on any call.

**16.2.5.4.2 Digital Impairments**

Digital impairments occur in the signal whenever it is transmitted in digital format. These errors are usually introduced upon conversion of the signal from analog to digital, as well as at interfaces between digital components. While many digital impairments have little impact on subjective voice quality, they can impact voiceband data performance.

**16.2.5.4.2.1 Signal Correlated Distortion**

**16.2.5.4.2.1.1** Signal correlated distortion (SCD) is unwanted noise or distortion introduced into a signal through the conversion of a signal from analog to digital format or through digital processing that changes the transmitted signal. SCD affects performance when a sign is being transmitted. The primary sources of SCD are signal encoders, echo cancelers, digital loss pads, and robbed bit signaling. SCD affects both voice and voiceband data performance.

**16.2.5.4.2.1.2** The NID-to-end-office connection shall allow:

**16.2.5.4.2.1.2.1** A maximum of 1 A/D conversion, using 64Kbps  $\mu$ -law ( $\mu=255$ ) PCM;

**16.2.5.4.2.1.2.2** No voice compression;

**16.2.5.4.2.1.2.3** No echo cancellation; and

**16.2.5.4.2.1.2.4** Robbed bit signaling only if SS7 or ISDN are not used.

**16.2.5.4.2.2 Slips**

**16.2.5.4.2.2.1** Slips occur when a frame of digital data is either deleted or repeated because of differences in the clocks used to synchronize digital facilities. Slips sound like clicks or pops on voice calls and have major impact on voiceband data performance.

**16.2.5.4.2.2.2** The NID-to-interexchange carrier point of termination portion of connections shall have fewer than 0.45 slips every 24 hours on average.

**16.2.5.4.2.3 Digital Timing Jitter and Wander**

**16.2.5.4.2.3.1** Digital timing jitter is the unwanted phase modulation of digital signals at rates above 10 Hz. Wander is the unwanted phase modulation of digital signals at rates below 10 Hz. Digital timing jitter is caused by imperfections in the timing recovery process of repeaters and the stuffing synchronization process used by multiplexer/demultiplexers. Wander is caused by slowly varying changes in digital signal phase due to clock frequency offset and drift, changes in propagation delay of terrestrial



facilities due to temperature changes and changes in the distance of satellites from the earth. These events have a major impact on voiceband data performance.

- 16.2.5.4.2.3.2 The maximum digital timing jitter allowed in the 10 Hz to 8 kHz frequency band at any network interface or any terminal equipment in the network is 5 Unit Intervals (UI). The maximum digital timing jitter allowed in the 8 kHz to 40 kHz frequency band is 0.1 UI. The objective for wander is less than 28 UI at any network interface or terminal equipment.
- 16.2.5.4.2.4 **DS-1 Errored Seconds**
- 16.2.5.4.2.4.1 An Errored Second (ES) on a DS-1 facility is any second during which at least 1 bit is in error. The impact of an ES on performance depends on the number of errors that occur during a second. Typically, voice performance is not significantly impacted by ES but they can cause errors in voiceband data transmissions.
- 16.2.5.4.2.4.2 Each BellSouth work shall have less than 20 ESs per 24 hour period.
- 16.2.5.4.2.5 **DS-1 Severely Errored Seconds**
- 16.2.5.4.2.5.1 A severely Errored Second (SES) is any second during which a DS-1 has an error rate exceeding 0.001. An SES can be caused by a loss of framing, a slip, or a protection switch. SESs have impacts on both voice and voiceband data performance. For voice, an SES will sound like a burst of noise or static. SESs that occur during a voiceband data transmission cause a significant burst of errors and can cause modems to retrain.
- 16.2.5.4.2.5.2 The digital portion of each NID to POP connection shall have less than 2 SESs per 24 hour period).
- 16.2.5.4.2.6 **Short Failure Events**
- 16.2.5.4.2.6.1 A Short Failure Event (SFE) is a Loss of Frame (LOF) event of less than two minutes' duration. An LOF event is declared when, on detection of a Loss of Signal (LOS) or Out-of-Frame (OOF), a rise-slope-type integration process starts that declares a LOF after  $2.5 \pm 0.5$  sec. of continuous LOS or OOF. If the LOS or OOF is intermittent, the integration process shall decay at a slope of 1/5 the rise slope during the period when the signal is normal. Thus, if the ratio of a LOS or OOF to a normal signal is greater than 1/2, a LOF will be declared. A LOS condition shall be declared when the Network Channel Terminating Equipment has determined that  $175 \pm 75$  successive pulse positions with

no pulses of either positive or negative polarity have occurred. An OCF condition shall be declared when either Network equipment or Digital Terminal Equipment detects errors in the framing pattern.

16.2.5.4 2.6.2 There shall be fewer than 1 SFE per month.

**16.2.5.5 Service Availability and Reliability**

Availability refers to the time period during which the service is up and usable for its intended purpose. Reliability refers to the probability that a task will be completed successfully, given that it is successfully begun. Where available BellSouth shall provide real-time, remote data access to performance monitoring and alarm data on events affecting (or potentially affecting) AT&T's traffic.

**16.2.5.5.1 Blocked Calls**

16.2.5.5.1.1 Blocking is the fraction of call origination attempts denied service during a stated measurement period. Blocking occurs because of competition for limited resources within the network.

16.2.5.5.1.2 For intraLATA toll service as well as for local exchange service, the blocking level from originating network interface (NID) to terminating NID shall not exceed 1% in any hour, except under conditions of service disruption. For access to or egress from the AT&T long distance network, the blocking rate shall not exceed 0.5% in any hour, except under conditions of service disruption.

**16.2.5.5.2 Blocked Dial Tone**

16.2.5.5.2.1 Blocked dial tone occurs when the subscriber does not receive dial tone within 3 seconds of going off-hook.

16.2.5.5.2.2 Customers shall not experience more than 0.1% dial tone blocking during average busy season busy hour (ABSBH).

**16.2.5.5.3 Downtime**

Downtime is the period of time that a system is in a failed state.

16.2.5.5.3.1 The average downtime for all subscriber Loop Combinations shall be less than 49 minutes per year. The maximum downtime for 99% of all subscriber Loop Combinations shall be less than 74 minutes per year.

16.2.5.5.3.2 The average downtime for an end office switch shall be less than 3 minutes per year. The average downtime for individual trunks shall be less than 28 minutes per year. The average downtime for digital trunk groups shall be less than 20 minutes per year. The average downtime

16.2.5.5.3.3	The mean time to repair (MTR) of any equipment at an attended site shall be less than 3 hours. The mean time to repair (MTR) of any equipment at an unattended site shall be less than 4 hours. 95% of all repairs to the network interface (NID) shall be completed within 24 hours
16.2.5.5.3.4	There shall be no downtime due to power failures at the switch
16.2.5.5.3.5	The probability of a stable call being cut off shall be less than 20 cutoffs per one million 1 minute calls.
16.2.5.5.3.6	The rate of ineffective machine attempts at the end office shall be less than 0.0005 (5 failures per 10,000 call attempts).
16.2.5.5.3.7	BellSouth shall meet all requirements for private line services in TR-NVT-000335, ANSI-T1.512-1994, and AT&T Technical References as listed in this Section 13.2.
16.2.5.5.4	Dial Tone Delay
16.2.5.5.4.1	Dial-Tone Delay is the time period between a customer off-hook and the receipt of dial tone from an originating end office. Dial-Tone Delay has a significant effect on customer opinion of service quality.
16.2.5.5.4.2	The average dial-tone delay shall not exceed 0.6 seconds. At most 0.5% of calls during the average-season busy hour (ASBH) shall experience dial-tone delay greater than 3 seconds. At most 8% of calls during the ten-high-day busy hour (THDBH) shall experience dial-tone delay greater than 3 seconds. At most 10% of calls during the high-day busy hour (HDBH) shall experience dial-tone delay greater than 3 seconds.
16.2.5.5.5	Dial Tone Removal
16.2.5.5.5.1	Dial tone removal is the time between recognition of the first address digit to the removal of dial tone on the line.
16.2.5.5.5.2	The maximum dial tone removal interval shall be ≤ 500 milliseconds.
16.2.5.5.6	Post Dial Delay
16.2.5.5.6.1	Post Dial Delay (PDD) is the amount of time a caller must wait after entering or dialing the last digit of a Destination Telephone Number

DTN) before hearing a valid audible network response. The PDD for an end user is measured from the time the caller has pressed or dialed the last digit of a DTN until receipt of an audible network response.

16.2.5.5.6.2 The requirements given reflect an end-to-end CCS7 protocol for AT&T end users. Where a mixture of CCS7 and inband (MF) signaling protocols are employed, an increase in the PDD can be expected.

**16.2.5.5.6.2.1 PDD 1 - A - Intra AT&T LSO**

16.2.5.5.6.2.1.1 Intra-LSO calls do not employ external signaling protocols. The PDD for intra-LSO calls flows are dependent upon the processor cycle time and traffic load conditions. This PDD is assumed to be between customers on the same AT&T LSO, between the Remote Switch Modules (RSMs) on the same Host, or between an RSM and 5ESS Host customers.

16.2.5.5.6.2.1.2 The objective for intra-LSO PDD is less than 310 milliseconds for 50% of all calls and less than 460 milliseconds for 95% of all calls.

**16.2.5.5.6.2.2 PDD1 - B - AT&T LSO to Another AT&T Local LSO**

16.2.5.5.6.2.2.1 The signaling protocols from an AT&T LSO to another AT&T LSO are assumed to employ out-of-band Common Channel Signaling System 7 (CCS7) format. Local calls, that is, calls from an AT&T LSO to another AT&T LSOs are assumed to have no more than one pair of Signaling Transfer Point Switches (STPSs) and no more than one data base dip.

16.2.5.5.6.2.2.2 This PDD is expected to be better than the AT&T Long Distance objective with an average PDD of  $\leq .870$  seconds with 95%  $\leq 1.34$  seconds.

**16.2.5.5.6.2.3 PDD1 - C - AT&T LSO to Other LSO**

16.2.5.5.6.2.3.1 Calls from an AT&T LSO to other LSOs are dependent upon the interface agreements between AT&T and the LSO service provider and may employ CCS7, inband (MF) or a combination of both protocols.

16.2.5.5.6.2.3.2 Calls from an AT&T LSO to another LSO via the Public Switched Telecommunications Network (PSTN), using end-to-end CCS7 signaling protocols, can expect to meet the AT&T PDD objectives of an average of 2.0 seconds with 95% in  $\leq 2.5$  seconds. Calls from an AT&T LSO via the PSTN to LSOs outside the local service area are assumed to use CCS7 signaling protocols to the AT&T #4ESS.™ The egress signaling protocols from the AT&T Switched Network (ASN) to the many different local telephone company service providers however does not necessarily

*UB*  
FL6/10/97

utilize CCS7 signaling. There are three basic egress signaling configuration. They are:

- 16.2.5.5.6.2.3.2.1 Network Inter-Connect. CCS7 between AT&T and the local telephone company.
- 16.2.5.5.6.2.3.2.2 Inband Multifrequency (MF) signaling protocols without a BellSouth egress tandem in the connection.
- 16.2.5.5.6.2.3.2.3 Inband MF signaling protocols with a BellSouth egress tandem in the connection.
- 13.2.4.6.3.2.3.2.3.1 Calls from an AT&T LSO to other LSOs outside the local service area are assumed to have multiple STPSs for 1+ traffic in the access and ASN portion of the connection. The egress from the ASN for 1+ traffic is again dependent upon the interface agreements in that service area and may consist of CCS7 or inband MF protocols.
- 13.2.4.6.3.2.3.2.3.2 Calls from an AT&T's LSO to another AT&T LSO with a mixture of CCS7 or all inband signaling protocols are expected to receive PDDs on the average of 2.9 seconds with 95% in  $\leq 6.5$  seconds.

#### **16.2.5.5.6.2.4 PDD2 - AT&T LSO to Operator Services**

16.2.5.5.6.2.4.1 The signaling protocols between an AT&T LSO and the AT&T ASN 5ESS® Operator Services Position Systems (OSPS) will employ IN-band Feature Group C Modified Operator Services Multifrequency signaling format. As with 1+ traffic, the egress from the ASN to the local service providers LSO is dependent upon the interface.

#### **16.2.5.5.6.2.5 PDD2 - A - AT&T LSO to 5ESS® OSPS 0 Only**

16.2.5.5.6.2.5.1 When a "0" has been entered by the customer, timing is applied in the absence of a DTMF "#". If a "#" is not entered, the objective is for the timer to expire in 4 seconds +/- 1 second. After the timer has expired, or the "#" has been entered, the average PDD shall not exceed 2.2 seconds.

#### **16.2.5.5.6.2.6 PDD2 - B - 0 Plus Calls**

On calls where analysis of the first 6 digits ( area code + central office code) is required, the PDD shall not exceed 2.0 seconds on the average, and 2.5 seconds in 95% of all occurrences. For calls that require analysis of the 10-digits CALLED number and the 7 digits of calling number (ANI, e.g. Automatic Charge Quotation Service) the PDD is expected to be 4.5 seconds on the average and < 5.0 seconds in 95% of all occurrences. These delays are based on the calling customer

receiving a network response as described above, specifically the calling card alerting tone from the 5ESS<sup>®</sup> OSPS. The remaining call completion PDD to the DTN, after the customer has completed the Operator Service function, will take the form of the PDDs discussed in PDD1-C.

#### **16.2.5.5.6.2.7 Impact of Local Number Portability (LNP)**

Local Number Portability will increase PDDs. If a call forwarding option is used as an interim solution for LNP, the delay due to additional switching in the local access is estimated to be 0.3 seconds (mean) and 0.4 seconds (95th percentile) in addition to the PDDs described earlier. These estimates assumes CCS7 signaling between LSOs. If inband signaling is used between LSOs, the PDD will be increased by 1.9 to 3.6 (1.7+1.9) seconds compared to the PDDs provided in the section on Post Dial Delay.

#### **16.2.5.5.6.2.8 Custom Local Area Subscriber Services (CLASS)**

CLASS<sup>SM</sup> features such as Calling Name Delivery can contribute to the PDD of a call. This delay is caused by the additional time (BellSouth option) before the ringing interval commences. This default delay is 3 seconds. Optional settings are available in 1 second intervals from 1 to 6 seconds. Calls to DTNs that have CLASS<sup>SM</sup> features, particularly with calling name delivery, can expect to experience from 1 to 6 seconds (3 seconds default) of additional PDD compared to the PDDs shown for PDD1-C.

#### **16.2.5.5.6.2.9 Partial Dial Timing**

- 16.2.5.5.6.2.9.1** The interval between each information digit from a customer's line, until the LSO or switching system has determined that the digit string is incomplete.
- 16.2.5.5.6.2.9.2** For customer lines, partial dial timing shall be  $\geq 16$  seconds and  $\leq 24$  seconds. For trunks, inband signaling time-out shall be  $\geq 5$  seconds and  $\leq 20$  seconds.

#### **16.2.5.6 Local Switching**

BellSouth shall provide performance equal to or better than the requirements for Local Switching set forth in Bellcore LSSGR TR-TSY-000511. Post dial delay for connections to AT&T local operator services shall be no worse than Operator Services provided by BellSouth. Additionally, post dial delay from the Operator Services to destination numbers shall be no worse than that provided by BellSouth. Post dial delay for connections to AT&T local Directory Assistance Services shall

be no worse than Directory Assistance Services provided by BellSouth. Additionally, post dial delay from the directory system to destination numbers shall be no worse than that provided by BellSouth. Specific requirements for the Data Switching function of Local Switching are in Section 5.3. In all cases the performance of Data Switching shall meet the general requirements stated in "General Performance Requirements." Allocation of impairments shall be negotiated between AT&T and BellSouth.

16.2.5.7

**Operator Systems**

Operator System connections shall comply with the requirements for the Loop Combination, Local Switching, Operator Service, and Directory Assistance Service requirements.

16.2.5.8

**Common Transport**

Specific requirements for this Network Element or Ancillary Function are in the Common Transport section. In all cases the performance of this Network Element shall meet the general requirements stated Section 16.2 of this Attachment 2. Allocation of impairments shall be negotiated between AT&T and BellSouth.

16.2.5.9

**Dedicated Transport**

Specific requirements for this Network Element are in the Dedicated Transport section. In all cases the performance of this Network Element shall meet the general requirements stated in "General Performance Requirements." Allocation of impairments shall be negotiated between AT&T and BellSouth.

16.2.5.10

**Signaling Transfer Points**

Specific requirements for this Network Element are in the Signaling Transfer Points section. In all cases the performance of this Network Element shall meet the general requirements stated in Section 16.2 of this Attachment 2. Allocation of impairments shall be negotiated between AT&T and BellSouth.

16.2.5.11

**Signaling Link Transport**

Specific requirements for this Network Element are in the Signaling Link Transport section. In all cases the performance of this Network Element shall meet the general requirements stated in "General Performance Requirements." Allocation of impairments shall be negotiated between AT&T and BellSouth.

16.2.5.12

**SCPs/Databases**

The performance requirements for databases (LNP, LIDB, E911, etc) vary depending on the database and the application(s) it supports. Database-specific performance requirements are included in the sections addressing individual Network Elements and in applicable Bellcore documents. In all cases, the query response time, availability, accuracy, updating capabilities, and other performance parameters shall at least be at parity with those services as provided to BellSouth or other customer.

**16.2.5.13 Tandem Switching**

Specific requirements for this Network Element are in the Tandem Switching section. In all cases the performance of this Network Element shall meet the general requirements stated in Section 16.21 of this Attachment 2. Allocation of impairments shall be negotiated between AT&T and BellSouth.

**16.2.6 Test and Verification**

**16.2.6.1** BellSouth shall permit AT&T to confirm acceptable performance of any Network Element.

**16.2.6.1.1** At AT&T's request, BellSouth will provide access to the Network Element sufficient for AT&T to test the performance of that Network Element to AT&T's satisfaction.

**16.2.6.1.2** At AT&T's request, BellSouth will perform tests to confirm acceptable performance and provide AT&T with documentation of test procedures and results acceptable to AT&T.

**16.3 Protection, Restoration, and Disaster Recovery**

**16.3.1 Scope:**

This Section refers specifically to requirements on the use of redundant network equipment and facilities for protection, restoration, and disaster recovery.

**16.3.2 Requirements**

**16.3.2.1** BellSouth shall provide protection, restoration, and disaster recovery capabilities at parity with those capabilities provided for their own services, facilities and equipment (e.g., equivalent circuit pack protection ratios, facility protection ratios).

*LB*  
FLS/10/97



- 16.3.2.2 BellSouth shall provide Network Elements and Ancillary Functions equal priority in protection, restoration, and disaster recovery as provided to their own services, facilities and equipment.
- 16.3.2.3 BellSouth shall provide Network Elements and Ancillary Functions equal priority in the use of spare equipment and facilities as provided to their own services, facilities and equipment.
- 16.3.2.4 On a nondiscriminatory basis as to other BellSouth customers, BellSouth shall restore Network Elements that are specific to AT&T end user customers on a priority basis as AT&T may designate.

#### 16.4 Synchronization

##### 16.4.1 Definition

Synchronization is the function which keeps all digital equipment in a communications network operating at the same average frequency. With respect to digital transmission, information is coded into discrete pulses. When these pulses are transmitted through a digital communications network, all synchronous Network Elements are traceable to a stable and accurate timing source. Network synchronization is accomplished by timing all synchronous Network Elements in the network to a stratum 1 source so that transmission from these network points have the same average line rate.

##### 16.4.2 Technical Requirements

The following requirements are applicable to the case where BellSouth provides synchronization to equipment that AT&T owns and operates within a BellSouth location. In addition, these requirements apply to synchronous equipment that is owned by BellSouth and is used to provide a Network Element to AT&T.

- 16.4.2.1 The synchronization of clocks within digital networks is divided into two parts: intra-building and inter-building. Within a building, a single clock is designated as the Building Integrated Timing Supply (BITS), which provides all of the DS1 and DS0 synchronization references required by other clocks in such building. This is referred to as intra-building synchronization. The BITS receives synchronization references from remotely located BITS. Synchronization of BITS between buildings is referred to as inter-building synchronization.

- 16.4.2.2 To implement a network synchronization plan, clocks within digital networks are divided into four stratum levels. All clocks in strata 2, 3, and 4 are synchronized to a stratum 1 clock, that is, they are traceable to a stratum 1 clock. A traceable reference is a reference that can be

traced back through some number of clocks to a stratum 1 source. Clocks in different strata are distinguished by their free running accuracy or by their stability during trouble conditions such as the loss of all synchronization references.

#### 16.4.2.2.1 Intra-Building

16.4.2.2.1.1 Within a building, there are different kinds of equipment that require synchronization at the DS1 and DS0 rates. Synchronization at the DS1 rate is accomplished by the frequency synchronizing presence of buffer stores at various DS1 transmission interfaces. Synchronization at the DS0 rate is accomplished by using a composite clock signal that phase synchronizes the clocks. Equipment requiring DS0 synchronization frequently does not have adequate buffer storage to accommodate the phase variations among different equipment. Control of phase variations to an acceptable level is accomplished by externally timing all interconnecting DS0 circuits to a single clock source and by limiting the interconnection of DS0 equipment to less than 1,500 cable feet. Therefore, a BITS shall provide DS1 and composite clock signals when appropriate. The composite signal is a 64-kHz 5/8<sup>th</sup> duty cycle, return to zero with a bipolar violation every eighth pulse (B8RZ).

#### 16.4.2.2.2 Inter-Building

16.4.2.2.2.1 BellSouth shall provide inter-building synchronization at the DS1 rate, and the BITS shall accept the primary and secondary synchronization links from BITS in other buildings. From hierarchical considerations, the BITS shall be the highest stratum clock within the building and BellSouth shall provide operations capabilities (this includes, but is not limited to: synchronization reference provisioning; synchronization reference status inquiries; timing mode status inquiries; and alarm conditions).

#### 16.4.3 Synchronization Distribution Requirements

16.4.3.1 Central office BITS shall contain redundant clocks meeting or exceeding the requirements for a stratum 2 clock as specified in ANSI T1.101-1994 and Bellcore TR-NWT-001244 *Clocks for the Synchronized Network: Common Generic Criteria*.

16.4.3.2 Central office BITS shall be powered by primary and backup power sources.

16.4.3.3 If both reference inputs to the BITS are interrupted or in a degraded mode (meaning off frequency greater than twice the minimum accuracy of the BITS, loss of frame, excessive bit errors, or in Alarm Indication Signal), then the stratum clock in the BITS shall provide the necessary

- bridge in timing to allow the network to operate without a frame repetition or deletion (slip free) with better performance than 1 frame repetition or deletion (slip) per week.
- 16.4.3.4 DS1s multiplexed into a SONET synchronous payload envelope within an STS-n (where n is defined in ANSI T1.105-1995) signal shall not be used as reference facilities for network synchronization.
- 16.4.3.5 The total number of Network Elements cascaded from the stratum 1 source shall be minimized.
- 16.4.3.6 A Network Element shall receive the synchronization reference signal only from another Network Element that contains a clock of equivalent or superior quality (stratum level).
- 16.4.3.7 BellSouth shall select for synchronization those facilities shown to have the greatest degree of availability (absence of outages).
- 16.4.3.8 Where possible, all primary and secondary synchronization facilities shall be physically diverse (this means the maximum feasible physical separation of synchronization equipment and cabling).
- 16.4.3.9 No timing loops shall be formed in any combination of primary and secondary facilities.
- 16.4.3.10 An Operations Support System (OSS) shall continuously monitor the BITS for synchronization related failures or degradation.
- 16.4.3.11 An OSS shall continuously monitor all equipment transporting synchronization facilities for synchronization related failures or degradation.
- 16.4.3.12 For non-SONET equipment, BellSouth shall provide synchronization facilities which, at a minimum, comply with the standards set forth in ANSI T1.101-1994.
- 16.4.3.13 For SONET equipment, BellSouth shall provide synchronization facilities that have time deviation (TDEV) for integration times greater than 0.05 seconds and less than or equal to 10 seconds, that is less than or equal to 10 nanoseconds. TDEV, in nanoseconds, for integration times greater than 10 seconds and less than 1000 seconds, shall be less than 3.1623 times the square-root of the integration time. For example, for integration times of 25 seconds, TDEV shall be less than 15.8 nanoseconds.
- 16.5 SS7 Network Interconnection

16.5.1

### Definition

Figure 9 depicts Signaling System 7 (SS7) Network Interconnection. SS7 Network Interconnection is the interconnection of AT&T local Signaling Transfer Point Switches (STPS) and AT&T local or tandem switching systems with BellSouth STPSs. This interconnection provides connectivity that enables the exchange of SS7 messages among BellSouth switching systems and databases (DBs), AT&T local or tandem switching systems, and other third-party switching systems directly connected to the BellSouth SS7 network.

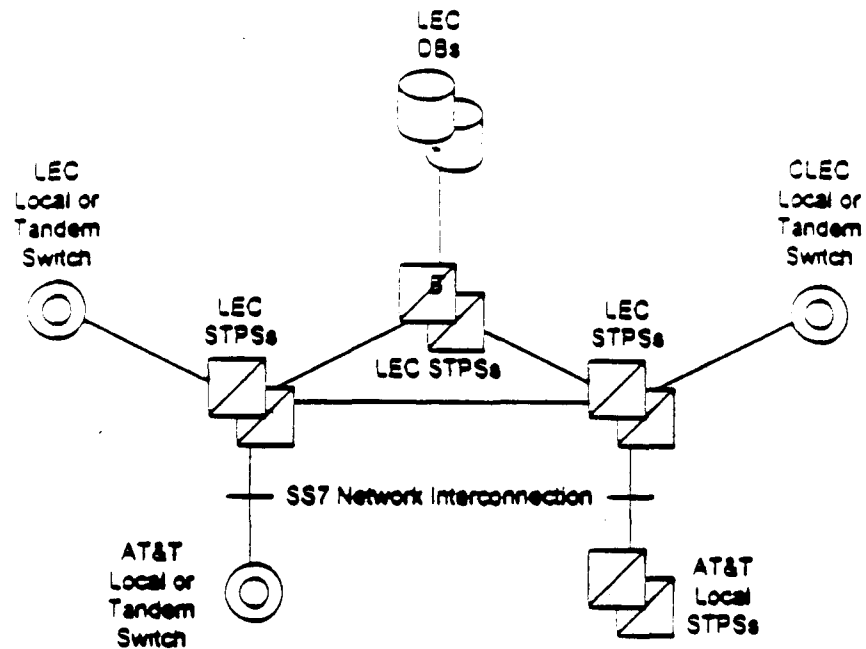

Figure 9. SS7 Network Interconnection

### 16.5.2 Technical Requirements

16.5.2.1 SS7 Network Interconnection shall provide connectivity to all components of the BellSouth SS7 network. These include:

- 16.5.2.1.1 BellSouth local or tandem switching systems;
- 16.5.2.1.2 BellSouth DBs; and
- 16.5.2.1.3 Other third-party local or tandem switching systems.

16.5.2.2 The connectivity provided by SS7 Network Interconnection shall fully support the functions of BellSouth switching systems and DBs and AT&T or other third-party switching systems with A-link access to the BellSouth SS7 network.

*MLB* FL6/10/97

16.5.2.3

In particular Figure 10 depicts a circumstance where SS7 Network Interconnection shall provide transport for certain types of Transaction Capabilities Application Part (TCAP) messages. If traffic is routed based on dialed or translated digits between an AT&T local switching system and a BellSouth or other third-party local switching system, either directly or via a BellSouth tandem switching system, then it is a requirement that the BellSouth SS7 network convey via SS7 Network Interconnection the TCAP messages that are necessary to provide Call Management services (Automatic Callback, Automatic Recall, and Screening List Editing) between the AT&T local STPSs and BellSouth or other third-party local switch.

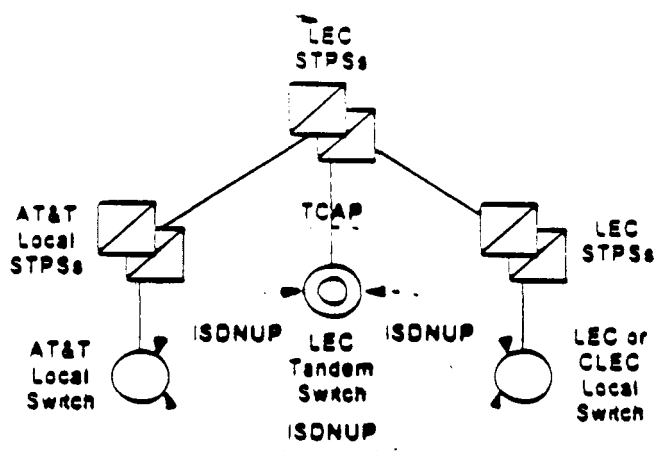

**Figure 10. Interswitch TCAP Signaling for SS7 Network Interconnection**

16.5.2.4

When the capability to route messages based on Intermediate Signaling Network Identifier (ISNI) is generally available on BellSouth STPSs, the BellSouth SS7 Network shall also convey TCAP messages using SS7 Network Interconnection in similar circumstances where the BellSouth switch routes traffic based on a Carrier Identification Code (CIC).

16.5.2.5

SS7 Network Interconnection shall provide all functions of the MTP as specified in ANSI T1.111 (Reference 16.5, 16.5.4, 16.5.4.2). This includes:

16.5.2.5.1

Signaling Data Link functions, as specified in ANSI T1.111.2;

16.5.2.5.2

Signaling Link functions, as specified in ANSI T1.111.3; and

*JFL* 6/10/97

- 16.5.2.5.3 Signaling Network Management functions, as specified in ANSI T1.111.4.
- 16.5.2.6 SS7 Network Interconnection shall provide all functions of the SCCP necessary for Class 0 (basic connectionless) service, as specified in ANSI T1.112 (Reference 16.5, 16.5.4, 16.5.4.4). In particular, this includes Global Title Translation (GTT) and SCCP Management procedures, as specified in T1.112.4. Where the destination signaling point is a BellSouth switching system or DB, or is another third-party local or tandem switching system directly connected to the BellSouth SS7 network, SS7 Network Interconnection shall include final GTT of messages to the destination and SCCP Subsystem Management of the destination. Where the destination signaling point is an AT&T local or tandem switching system, SS7 Network Interconnection shall include intermediate GTT of messages to a gateway pair of AT&T local STPSs, and shall not include SCCP Subsystem Management of the destination.
- 16.5.2.7 SS7 Network Interconnection shall provide all functions of the Integrated Services Digital Network User Part (ISDNUP), as specified in ANSI T1.113 (Reference 16.5, 16.5.4, 16.5.4.5).
- 16.5.2.8 SS7 Network Interconnection shall provide all functions of the TCAP, as specified in ANSI T1.114 (Reference 16.5, 16.5.4, 16.5.4.6).
- 16.5.2.9 If and when Internetwork MTP Routing Verification Test (MRVT) and SCCP Routing Verification Test (SRVT) become approved ANSI standards and available capabilities of BellSouth STPSs, SS7 Network Interconnection shall provide these functions of the OMAP.
- 16.5.2.10 SS7 Network Interconnection shall be equal to or better than the following performance requirements:
  - 16.5.2.10.1 MTP Performance, as specified in ANSI T1.111.6;
  - 16.5.2.10.2 SCCP Performance, as specified in ANSI T1.112.5; and
  - 16.5.2.10.3 ISDNUP Performance, as specified in ANSI T1.113.5.
- 16.5.3 **Interface Requirements**
  - 16.5.3.1 BellSouth shall offer the following SS7 Network Interconnection options to connect AT&T or AT&T-designated local or tandem switching systems or STPSs to the BellSouth SS7 network:
    - 16.5.3.1.1 A-link interface from AT&T local or tandem switching systems; and
    - 16.5.3.1.2 D-link interface from AT&T STPSs.

MB FL6/10/97

- 16.5.3.2 Each interface shall be provided by one or more sets (layers) of signaling links, as follows
- 16.5.3.2.1 An A-link layer shall consist of two links, as depicted in Figure 11

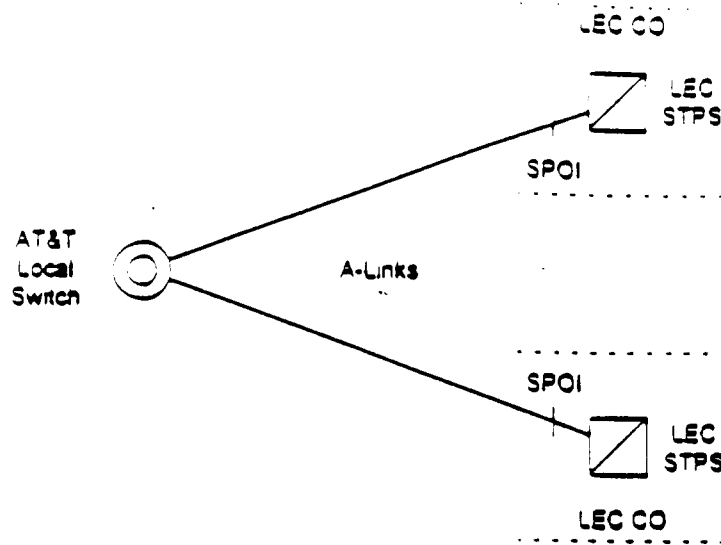

**Figure 11. A-Link Interface**

16.5.3.2.2

A D-link layer shall consist of four links, as depicted in Figure 12.

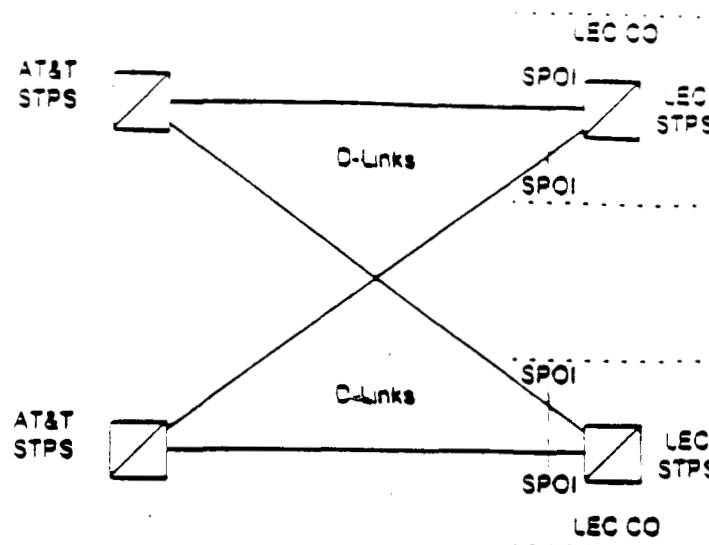

Figure 12. D-Link Interface

16.5.3.3

The Signaling Point of Interconnection (SPOI) for each link shall be located at a cross-connect element, such as a DSX-1, in the Central Office (CO) where the BellSouth STPS is located. There shall be a DS1 or higher rate transport interface at each of the SPOIs. Each signaling link shall appear as a DS0 channel within the DS1 or higher rate interface. BellSouth shall offer higher rate DS1 signaling links for interconnecting AT&T local switching systems or STPSs with BellSouth STPSs as soon as these become approved ANSI standards and available capabilities of BellSouth STPSs. BellSouth and AT&T will work jointly to establish mutually acceptable SPOI.

16.5.3.4

BellSouth CO shall provide intraoffice diversity between the SPOIs and the BellSouth STPS, so that no single failure of intraoffice facilities or equipment shall cause the failure of both D-links in a layer connecting to a BellSouth STPS. BellSouth and AT&T will work jointly to establish mutually acceptable SPOI.

16.5.3.5

The protocol interface requirements for SS7 Network Interconnection include the MTP, ISDNUP, SCCP, and TCAP. These protocol interfaces shall conform to the following specifications:

16.5.3.5.1

Bellcore GR-905-CORE, Common Channel Signaling Network Interface Specification (CCSNIS) Supporting Network Interconnection, Message



Transfer Part (MTP), and Integrated Services Digital Network User Part (ISDNUP).

- 16.5.3.5.2 Bellcore GR-1428-CORE, CCS Network Interface Specification (CCSNIS) Supporting Toll Free Service;
- 16.5.3.5.3 Bellcore GR-1429-CORE, CCS Network Interface Specification (CCSNIS) Supporting Call Management Services; and
- 16.5.3.5.4 Bellcore GR-1432-CORE, CCS Network Interface Specification (CCSNIS) Supporting Signaling Connection Control Part (SCCP) and Transaction Capabilities Application Part (TCAP).
- 16.5.3.6 BellSouth shall set message screening parameters to block accept messages from AT&T local or tandem switching systems destined to any signaling point in the BellSouth SS7 network with which the AT&T switching system has a legitimate signaling relation.
- 16.5.4 SS7 Network Interconnection shall be equal to or better than all of the requirements for SS7 Network Interconnection set forth in the following technical references:
  - 16.5.4.1 ANSI T1.110-1992 American National Standard Telecommunications - Signaling System Number 7 (SS7) - General Information;
  - 16.5.4.2 ANSI T1.111-1992 American National Standard for Telecommunications - Signaling System Number 7 (SS7) - Message Transfer Part (MTP);
  - 16.5.4.3 ANSI T1.111A-1994 American National Standard for Telecommunications - Signaling System Number 7 (SS7) - Message Transfer Part (MTP) Supplement;
  - 16.5.4.4 ANSI T1.112-1992 American National Standard for Telecommunications - Signaling System Number 7 (SS7) - Signaling Connection Control Part (SCCP);
  - 16.5.4.5 ANSI T1.113-1995 American National Standard for Telecommunications - Signaling System Number 7 (SS7) - Integrated Services Digital Network (ISDN) User Part;
  - 16.5.4.6 ANSI T1.114-1992 American National Standard for Telecommunications - Signaling System Number 7 (SS7) - Transaction Capabilities Application Part (TCAP);
  - 16.5.4.7 ANSI T1.115-1990 American National Standard for Telecommunications - Signaling System Number 7 (SS7) - Monitoring and Measurements for Networks;

- 16.5.4.8 ANSI T1-116-1990 American National Standard for Telecommunications - Signaling System Number 7 (SS7) - Operations, Maintenance and Administration Part (OMAP).
- 16.5.4.9 ANSI T1-118-1992 American National Standard for Telecommunications - Signaling System Number 7 (SS7) - Intermediate Signaling Network Identification (ISNI);
- 16.5.4.10 Bellcore GR-905-CORE, Common Channel Signaling Network Interface Specification (CCSNIS) Supporting Network Interconnection, Message Transfer Part (MTP), and Integrated Services Digital Network User Part (ISDNUP);
- 16.5.4.11 Bellcore GR-954-CORE, CCS Network Interface Specification (CCSNIS) Supporting Line Information Database (LIDB) Service;
- 16.5.4.12 Bellcore GR-1428-CORE, CCS Network Interface Specification (CCSNIS) Supporting Toll Free Service;
- 16.5.4.13 Bellcore GR-1429-CORE, CCS Network Interface Specification (CCSNIS) Supporting Call Management Services; and,
- 16.5.4.14 Bellcore GR-1432-CORE, CCS Network Interface Specification (CCSNIS) Supporting Signaling Connection Control Part (SCCP) and Transaction Capabilities Application Part (TCAP).
- 16.6 **Network Interconnection**
  - 16.6.1 **Technical Requirements**
    - 16.6.1.1 When requested by AT&T, BellSouth shall provide interconnections between BellSouth Network Elements provided to AT&T and AT&T's network at transmission rates designated by AT&T, including, but not limited to DS1, DS3, and STS-1.
    - 16.6.1.2 Traffic shall be combined and routed as follows:
      - 16.6.1.2.1 BellSouth shall provide direct trunks for local and intraLATA traffic (except 911, directory assistance, operator services, and other services that may require special routing) and, at AT&T's request, BellSouth shall allow AT&T to route such traffic either directly to a BellSouth's tandem or directly to a BellSouth's end-office.
      - 16.6.1.2.2 At AT&T's request, BellSouth shall receive AT&T traffic destined to BellSouth Operator Systems Network Element, on trunks from an AT&T end-office or an AT&T tandem.

- 16.6.1.2.3 At AT&T's request, BellSouth shall receive AT&T CAMA-ANI (Centralized Automatic Message Accounting - Automatic Number Identification) traffic destined to BellSouth 8911 PSAPs, or 8911 tandems, on trunks from an AT&T end-office.
- 16.6.1.2.4 **DELETED**
- 16.6.1.3 When requested by AT&T and a third party carrier, BellSouth shall provide interconnections between AT&T's network, and the other carrier's network through BellSouth network at transmission rates designated by AT&T, including, but not limited to DS1, DS3, and STS-1. BellSouth shall combine and route traffic to and from other local carriers and interLATA carriers through BellSouth network, and at AT&T's request, BellSouth shall record and keep records of such traffic for AT&T billing purposes.
- 16.6.1.4 The parties agree to implement the most efficient trunking arrangement to exchange all traffic unless otherwise agreed. For purposes of this Section, "most efficient" means the fewest number of trunks required to carry a forecasted load at P.01 grade of service. Initially, BellSouth will provide one-way trunk groups for completion of BellSouth originated local and intraLATA traffic and AT&T will provide two-way trunk groups for completion of AT&T originated local and intraLATA traffic. AT&T and BellSouth will continue to utilize existing separate two-way trunk groups for the origination and termination of interLATA traffic. This arrangement is depicted in Figure A.

BellSouth and AT&T each agree to use best efforts to implement the most efficient interconnection architecture. The parties agree to meet every six months for the duration of this Agreement commencing with the Effective Date to analyze the trunk recording capabilities and define the administration M&Ps by which Figure B can be properly implemented. When these M&Ps are agreed to by the parties, BellSouth and AT&T will utilize two way trunks for origination and termination of local and intraLATA traffic.

BellSouth and AT&T further agree to implement the most efficient trunking arrangement, as depicted by Figure C, within twelve (12) months of industry agreement on arrangements to pass Carrier Identification Codes on all calls exchanged between two different service providers' networks.

TRUNKING

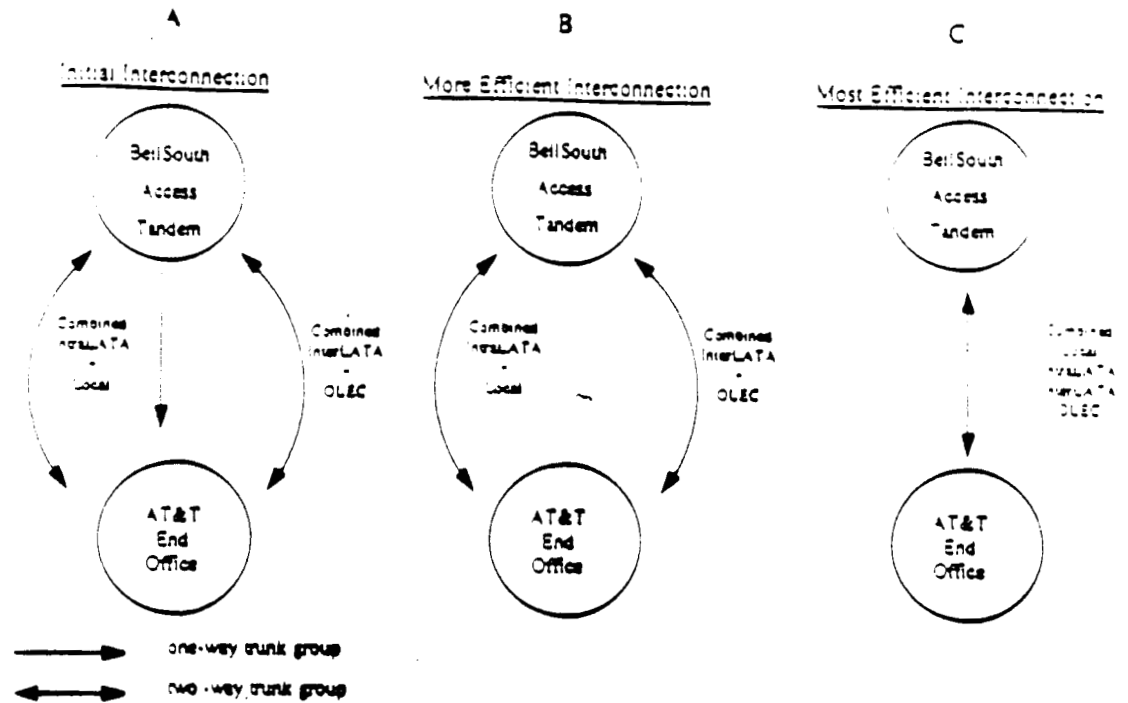

- 16.6.1.5 **DELETED**
- 16.6.1.6 All trunking provided by BellSouth shall adhere to the applicable performance requirements set forth in Section 16.2 of Attachment 2.
- 16.6.1.7 At AT&T's request, BellSouth shall provide for overflow routing from a given high usage trunk group or groups onto another final tandem trunk group.
- 16.6.1.8 BellSouth and AT&T shall agree on the establishment of two-way trunk groups for the exchange of traffic for other IXCs. These trunk groups can be provided in a "meet point" arrangement.
- 16.6.1.9 Interconnection shall be made available upon AT&T's request at any technically feasible point of interface. All trunk interconnections shall be provided, including, SS7, MF, DTMF, DialPulse, PRI-ISDN (where available), DID (Direct Inward Dialing), CAMA-ANI, and trunking necessary so that interim LNP can be provided.
- 16.6.1.10 **Trunk Interface Requirements**
- 16.6.1.10.1 **B911/E911 Trunks**

JP FL6/10/97

- 16.6.1.10.1.1 **DELETED**
- 16.6.1.10.1.2 If a municipality has converted to E911 service, AT&T will forward 911 calls to the appropriate E911 primary tandem, along with ANI, based upon the current E911 end office to tandem homing arrangement as provided by BellSouth. If the primary tandem trunks are not available AT&T will alternatively route the call to a designated 7-digit local number residing in the appropriate PSAP. This call will be transported over BellSouth's interoffice network and will not carry the ANI of the calling party, which is in party with BellSouth's handling of 911 calls from its customers.
- 16.6.1.10.2 **S911 Trunks**
- 16.6.1.10.3 **Local Switch and Access Tandem Trunks**
- 16.6.1.10.3.1 BellSouth shall provide trunks groups provisioned exclusively to carry intraLATA traffic, as designated by AT&T.
- 16.6.1.10.3.2 BellSouth shall provide trunk groups provisioned exclusively to carry interLATA traffic, as designated by AT&T.
- 16.6.1.10.3.3 BellSouth shall provide SS7 trunks which provide SS7 interconnection. At AT&T's request, MF trunks may be substituted for SS7 trunks where applicable.
- 16.6.1.10.3.4 [BellSouth shall simultaneous route calls based on dialed digits (in accordance with the standard GR-317-CORE), and Carrier Identification Code (in accordance with the standard GR-394-CORE) over a single SS7 trunk group.]
- 16.6.1.10.4 **BellSouth Operator Services Trunk**
- 16.6.1.10.4.1 For traffic from BellSouth's network to AT&T for Operator Services, BellSouth shall provide one trunk group per NPA served by the local BellSouth switch.
- 16.6.1.10.4.2 BellSouth shall provide such trunks as one-way trunks from BellSouth network to the AT&T network.
- 16.6.2 **Network Interconnection between BellSouth and AT&T shall meet or exceed all of the requirements for Network Interconnection set forth in the following technical references:**
- 16.6.2.1 **GR-317-CORE, Switching System generic requirements for Call Control Using the Integrated Services Digital Network User Part (ISDNUP), Bellcore, February, 1994;**

  
FL6/10/97

- 16.6.2.2 GR-394-CORE, Switching System generic requirements for Interexchange Carrier Interconnection Using the Integrated Services Digital Network User Part (ISDNUP), Bellcore, February, 1994
- 16.6.2.3 FR-NWT-000271, OSSGR Operator Services Systems generic requirements, Bellcore, 1994 Edition; and
- 16.6.2.4 FR-NWT-000064, LATA Switching Systems Generic Requirements (LSSGR), Bellcore, 1994 Edition.
- 16.7 **Basic 911 and E911**
- 16.7.1 **Definition**

Basic 911 and E911 is an additional requirement that provides a caller access to the applicable emergency service bureau by dialing a 3-digit universal telephone number (911).
- 16.7.2 **Requirements**
- 16.7.2.1 Basic 911 shall collect 911 calls from one or more local exchange switches that serve a geographic area. It shall then send these calls to the correct authority designated to receive such calls.
- 16.7.2.2 E911 shall provide additional routing flexibility for 911 calls. E911 shall use customer data, contained in the Automatic Location Identification/Data Management System (ALI/DMS), to determine to which Public Safety Answering Point (PSAP) to route the call.
- 16.7.2.3 **DELETED**
- 16.7.2.4 Basic 911 and E911 functions provided to AT&T shall be at least at parity with the support and services that BellSouth provides to its customers for such similar functionality.
- 16.7.2.5 Basic 911 and E911 access from Local Switching shall be provided to AT&T in accordance with the following:
  - 16.7.2.5.1 BellSouth shall conform to all state regulations concerning emergency services;
  - 16.7.2.5.2 BellSouth shall route calls to the appropriate PSAP.
  - 16.7.2.5.3 For B911, BellSouth shall provide voice only to the appropriate PSAP.
  - 16.7.2.5.4 For E911, BellSouth shall use the process as described in the E911 Local Exchange Carrier Guide for Facility-Based Providers (ALEC

Guide) to update and maintain customer information in the ALI/DMS database. BellSouth shall provide and validate customer information resident or entered into the ALI/DMS database

16.7.2.5.5

**DELETED**

16.7.2.6

Basic 911 and E911 access from the AT&T local switch shall be provided to AT&T in accordance with the following:

16.7.2.6.1

If required by AT&T, BellSouth shall interconnect direct trunks from the AT&T network to the B911 PSAP, or the E911 tandems as designated by AT&T. Such trunks may alternatively be provided by AT&T

16.7.2.6.2

For E911, BellSouth, shall receive data from AT&T as described in the ALEC Guide (electronically via FTS or NDM). Errors will be mechanically faxed to AT&T shortly after the errors are detected by the update process. AT&T will transmit daily update files for "batch" processing within 24 hours of receipt of a "good file".

16.7.2.6.3

BellSouth shall provide AT&T with an initial Master Street and Address Guide (MSAG) (paper or magnetic tape) no later than [date to be provided], and will provide updates of this MSG quarterly.

16.8

**Electronic Interface**

BellSouth shall provide real time Electronic Interfaces ("EI") for transferring and receiving Service Orders and Provisioning data and materials (e.g., access Street Address Guide ("SAG") and Telephone Number Assignment database) as specified in Attachment 15. These interfaces shall be administered through a gateway that will serve as a point of contact for the transmission of such data from AT&T to BellSouth, and from BellSouth to AT&T. The requirements and implementation of such a data transfer system shall be negotiated in good faith by the parties as specified in Attachments 4, 5 and 15 of this Agreement. AT&T and BellSouth have agreed upon interim solutions described in Attachments 4, 5 and 15. Until such time as a gateway addressing Pre-Ordering and Provisioning interfaces is established, BellSouth shall provide AT&T Customers with the same quality of service BellSouth provides itself, a subsidiary, an Affiliate or any other customer.

TABLE OF CONTENTS

SERVICE DESCRIPTION: ANCILLARY FUNCTIONS

1. Introduction.....	1
2. Collocation.....	1
3. Rights of Way (ROW), Conducts and Pole Attachments.....	7



- 3.20.2.2 Charges associated with newly licensed attachments or occupancies and other attachments or occupancies of less than the entire annual billing period shall be prorated.
- 3.20.2.3 Charges shall be prorated retroactively in the event of the removal of AT&T's facilities.
- 3.20.3 DELETED
- 3.20.3.1 DELETED
- 3.20.3.2 DELETED
- 3.20.4 The amount of any advance payment required under this Article 3.20 shall be due within sixty (60) days after receipt of an invoice from BellSouth.
- 3.20.5 Imputation. BellSouth shall impute to its costs of providing telecommunications services (and charge any affiliate, subsidiary, or associate company engaged in the provision of such services) an equal amount to the charges set forth in this Section for all of the conduits, ducts, and poles it occupies and uses.
- 3.21 DELETED
- 3.21.1 DELETED
- 3.21.1.1 DELETED
- 3.21.1.2 DELETED
- 3.21.1.3 DELETED
- 3.21.2 DELETED
- 3.21.3 DELETED
- 3.22 **ASSURANCE OF PAYMENT**
- 3.22.1 In the event AT&T fails to demonstrate credit worthiness, AT&T may be required to furnish a bond, letter of credit or other evidence of financial security having a minimum face amount of \$10,000.00 per state or \$50,000.00 per region. Such bond, letter of credit or other security shall be in a form satisfactory to BellSouth and may be increased from time to time as reasonably required by BellSouth to guarantee the performance of all obligations of AT&T hereunder. The amount of the bond, letter of credit or other security shall not operate as a limitation upon the obligations of AT&T hereunder.

*JB* FL6/10/97

EXHIBIT I  
DELETED

**Exhibit II**

**ADMINISTRATIVE FORMS AND NOTICES**

This Exhibit II lists the types of administrative forms to be utilized in connection with this Section .

**LIST OF ADMINISTRATIVE FORMS**

Authorization for Make-Ready Work  
Application and Conduit Occupancy License  
Conduit System Diagram  
Cable to Occupy Conduit  
Equipment Housings to be Placed in manholes  
Notification of Surrender or Modification of Conduit  
Occupancy License by Licenses  
Notifications of Unauthorized Attachments by Applicant  
Application and Pole Attachment License  
Pole, Anchor and Guy Strand Details  
Application and Unused Transmission Media License  
Application Survey Data  
Notification of Surrender or Modification of Pole  
Attachment License by Licenses

## TABLE OF CONTENTS

	<u>Page</u>
<b>PROVISIONING AND ORDERING</b>	
1. Network Deployment.....	4
2. General Provisioning Requirements.....	4
3. Specific Provisioning Process Requirements.....	2
4. General Ordering Requirements.....	4
5. Ordering Interfaces.....	5
6. BellSouth Provision of Information.....	6
7. Order Format and Data Elements for Individual Network Elements.....	6
8. DELETED.....	6
9. Performance Requirements.....	6

## Provisioning and Ordering

### Network Deployment

- 1.1 BellSouth shall deploy and maintain network facilities in all its serving areas in every LATA from and after the Effective Date of this Agreement as necessary to provide on a timely basis each of the Elements or Combinations thereof, as defined below, that BellSouth is required to offer to AT&T pursuant to this Agreement.
- 1.2 Throughout the term of this Agreement, the quality of the technology, equipment, facilities, processes, and techniques (including, without limitation, such new architecture, equipment, facilities, and interfaces as BellSouth may deploy) that BellSouth provides to AT&T under this Agreement shall be in accordance with standards or other measurements that are at least equal to the highest level that BellSouth provides or is required to provide by law and its own internal procedures.

### 2. General Provisioning Requirements

#### 2.1 DELETED

- 2.2 Combinations, consistent with Section 1.A of the General Terms and Conditions of this Agreement, shall be identified and described by AT&T so that they can be ordered and provisioned together and shall not require the enumeration of each Element within that Combination on each provisioning order. Multiple individual Elements may be ordered by AT&T from BellSouth on a single order without the need to have AT&T send an order for each Element. Until Electronic Interfaces are in place to meet these requirements, AT&T and BellSouth will use best efforts to develop an interim process by no later than April 1, 1997 to meet these requirements.

#### 2.3 DELETED

- 2.4 BellSouth shall provide provisioning services to AT&T equal to the provisioning services BellSouth provides to itself during normal business hours. If AT&T requests that BellSouth perform provisioning services at times or on days other than as set forth in the preceding sentence, BellSouth and AT&T shall mutually negotiate such provisioning including time interval and cost.

- 2.5 To ensure that AT&T's Customers have the same ordering experience as BellSouth's Customers:

  
FL6/10/97

- 2.5.1 BellSouth shall provide AT&T with the capability to have AT&T's Customer orders input to and accepted by BellSouth's Service Order Systems outside of normal business hours, twenty-four (24) hours a day, seven (7) days a week the same as BellSouth's Customer orders received outside of normal business orders are input and accepted.
- 2.5.2 Such ordering and provisioning capability shall be provided via an electronic interface, except for scheduled electronic interface downtime. Downtime shall not be scheduled during normal business hours and shall occur during times where systems experience minimum usage.
- 2.5.3 Until the Electronic Interface is available, BellSouth shall provide Local Carrier Service Center (LCSC) and Interexchange Carrier Service Center (ICSC) order entry capability to AT&T.
- 2.6 BellSouth shall provide a Single Point of Contact (SPOC) for all ordering and provisioning contacts and order flow involved in the purchase and provisioning of the BellSouth's unbundled Elements or Combinations. BellSouth's SPOC shall provide to AT&T a toll-free nation-wide telephone number (operational from 8:00 a.m. to 5:00 p.m., Monday through Friday, within each respective continental U.S. time zone) which will be answered by capable staff trained to answer questions and resolve problems in connection with the provisioning of Elements or Combinations.
- 2.7 BellSouth will recognize AT&T as the customer of record of all Elements or Combinations ordered by AT&T and will send all notices, invoices and pertinent information directly to AT&T.

3. **Specific Provisioning Process Requirements**

- 3.1 When AT&T orders the Local Switching Elements (either individually or as part of a Combination), AT&T may also obtain all technically available features and functions from the specified BellSouth switch (e.g., BRCS, CLASS, and LASS features).
- 3.2 When requested by AT&T, BellSouth will schedule installation appointments on a non-discriminatory basis with the BellSouth representative on the line with AT&T's representative. When electronic interfaces are available, BellSouth will provide AT&T with access to BellSouth's scheduling system. Prior to AT&T sending BellSouth the first service order, AT&T shall review the procedures that all BellSouth service technicians who provide installation service for AT&T customers shall follow in all of their communications with AT&T customers. At a minimum, the aforementioned procedures shall assume that: (1) BellSouth technicians shall provide repair service that is at least equal in quality to that provided to BellSouth customers; (2) trouble calls

  
FL6/10/97

from AT&T Customers shall receive response time priority that is at least equal to that of BellSouth customers and shall be handled on a "first come first served" basis regardless of whether the customer is an AT&T Customer or a BellSouth customer.

- 3.3 Upon request from AT&T, BellSouth will provide an intercept referral message in Tandem Switching Element that includes any new AT&T telephone number, for the same duration as is provided to BellSouth end-users. This message shall be approved by AT&T and shall be similar in format to the intercept referral messages currently provided by BellSouth for its own end-users.
- 3.4 The Confirmation will provide AT&T with the BellSouth order number, the negotiated service due date, telephone/circuit numbers (as applicable to the service), and the BellSouth service representative name and telephone number. Additional specific data may also be provided, if appropriate.
- 3.5 BellSouth will notify AT&T using the same interface used by AT&T to submit the service order request. When a BellSouth Technician is dispatched to complete the order, the service technician will contact AT&T at the time of completion.
- 3.6 BellSouth will perform pre-service testing as per industry standards and will provide in writing, or electronically as directed by AT&T, all test and turn-up results in support of the Elements or Combinations ordered by AT&T. BellSouth shall provide these test results to AT&T at the same time BellSouth provides its order-specific Order Completion.
- 3.7 As soon as identified, BellSouth shall notify AT&T via electronic interface, when available, of Rejections/Errors contained in any of the data element(s) fields contained on any AT&T Service Request. In the interim, BellSouth will notify AT&T by telephone or facsimile of such Rejections/Errors.
- 3.8 As soon as identified, BellSouth shall notify AT&T via electronic interface, when available (unless otherwise notified by AT&T) of any instances when BellSouth's Committed Due Dates are in jeopardy of not being met by BellSouth on any element or feature contained in any order for Network Elements or Combinations. BellSouth shall concurrently indicate its new committed due date. In the interim, BellSouth will notify AT&T by telephone or facsimile of such jeopardy.
- 3.9 BellSouth will perform testing with AT&T to test Elements and Combinations purchased by AT&T.
- 3.10 DELETED
- 3.11 DELETED

  
FL6/10/97

- 3.12 AT&T, where available, may choose between SCE/SMS AIN Access and SS7 AIN Access as designated on AT&T's provisioning order.
- 3.13 BellSouth shall inform AT&T if a customer action results in reassignment of an AIN trigger from an AT&T AIN application to some other service providers application. Such notification shall be completed within twenty-four (24) hours of the action via electronic interface as described in the Account Maintenance requirements specified in the Customer Billing section of this Agreement.
- 3.14 BellSouth shall maintain a database containing AIN trigger configuration and other data necessary to allow AIN service and feature interactions to be determined by AT&T. BellSouth shall provide AT&T the capability to make queries on a demand basis to such database. AT&T recognizes certain combinations of triggers cannot be active simultaneously on a directory number. Information regarding such conflicts will be provided to AT&T at the time of request.
- 3.15 BellSouth shall provision AIN triggers as requested by AT&T on its provisioning order. BellSouth will not remove a trigger at the request of an end-user. If an end-user requests removal of a trigger that has been provisioned at the request of AT&T, the end user will be referred to AT&T.

#### 4. General Ordering Requirements

- 4.1 Upon AT&T's request through a Suspend/Restore Order, BellSouth shall suspend or restore the functionality of any Network Element or Combination. On a non-discriminatory basis as to other BellSouth customers, BellSouth shall implement any restoration priority on a per Network Element or Combination basis in a manner that conforms with AT&T requested priorities.
- 4.2 BellSouth shall provide to AT&T the functionality of blocking calls (e.g., 800, 900, 976 international calls) on an individual switching element basis.
- 4.3 When ordering a Local Switching Element, AT&T may order from BellSouth separate interLATA and intraLATA capabilities (i.e., 2 PICs where available).
- 4.4 Unless otherwise directed by AT&T, when AT&T orders an Element or Combination, all pre-assigned trunk or telephone numbers currently associated with that Network Element or Combination shall be retained without loss of feature capability and without loss of associated functions including, but not limited to, Directory Assistance and 911/E911 capability, capability where such features or functions exist.
- 4.5 When AT&T orders Elements or Combinations that are currently interconnected and functional, such Elements and Combinations will remain

  
FL6/10/97



interconnected and functional without any disconnection or disruption of functionality. This shall be known as Contiguous Network Interconnection of network elements.

5. Ordering Interfaces

5.1 BellSouth shall provide real time electronic interfaces ("EI") for transferring and receiving Service Orders and Provisioning data as specified in Section 16.8 of Attachment 2 and in Attachment 15.

5.2 BellSouth shall provide real time provisioning data via an electronic interface as described in item 5.1 of this section. Provisioning data shall include providing AT&T the ability: (i) to obtain information on all features and services available, in end-office where customer is provisioned; (ii) to establish if a service call is needed to install the line or service; (iii) to determine the due date and provide information regarding service dispatch/installation schedule, if applicable; (iv) ability to provide an assigned telephone number; and (v) ability to obtain a customer profile, including customer name, billing and residence address, billed telephone numbers, and identification of features and services subscribed to by customer as set forth in Attachment 15.

5.2.1 DELETED

5.2.2 DELETED

5.2.3 DELETED

5.2.4 DELETED

5.2.5 DELETED

5.2.6 DELETED

5.2.7 DELETED

5.2.8 DELETED

5.2.9 DELETED

5.2.10 DELETED

5.3 BellSouth shall provide the ability to enter a service order via Electronic Interface as described in Subsection 5.1 of this Section. The service order shall provide AT&T the ability to: (i) establish service and order desired features; (ii) establish the appropriate directory listing; and (iii) order intraLATA toll and interLATA toll when applicable in a single, unified order.

  
FL6/10/97

6 BellSouth Provision of Information

6.1 BellSouth shall provide to AT&T with the initial services request:

6.1.1 DELETED

6.1.2 DELETED

6.1.3 When available with the normal request process, all engineering design and layout information for each network Element and Combination;

6.1.4 A listing of all technically available functionalities for each Element or Combination; and

6.1.5 Advanced information on the details and requirement for planning and implementation of NPA splits.

6.2 DELETED

7. Order Format and Data Elements for Individual Network Elements

7.1 AT&T may purchase Network Elements either individually or in Combinations. Combinations can be ordered (i) on a case-by-case basis for those Network Elements that are customer specific; or (ii) on a common use basis for those Network Elements that are shared by multiple customers.

7.2 In ordering Network Elements or Combinations, AT&T will utilize standard industry order formats and data elements developed by the Ordering and Billing Forum (OBF). Until such industry standard order formats and data elements are finalized for all Network Elements, AT&T and BellSouth will use best efforts to develop an interim process by no later than April 1, 1997 to meet these requirements. Such interim process will utilize the jointly developed EDI ordering interface, the existing ASR ordering interface, and manual intervention as required.

8. DELETED

9. Performance Requirements

9.1 AT&T will specify on each order its Desired Due Date (DDD) for completion of that particular order. BellSouth shall not complete the order prior to DDD unless early turn-up is needed for testing purposes. BellSouth will notify AT&T if the DDD cannot be met. BellSouth will make best effort to meet the DDD for Network Element requests.

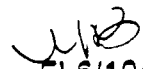
  
FL6/10/97

9.2 BellSouth and AT&T shall agree upon a minimum interval for the provisioning of each Network Element and appropriate expedite and escalation processes as part of a workcenter interface agreement.

9.3 DELETED.

9.4 DELETED

## MAINTENANCE

1. BellSouth shall provide repair, maintenance, testing, and surveillance for all Local Services and Unbundled Network Elements and Combinations in accordance with the terms and conditions of this Attachment. BellSouth will provide AT&T with at least the capability to provide an AT&T customer the same experience as BellSouth provides its own customers. The capability provided to AT&T by BellSouth shall be in accordance with standards or other measurements that are at least equal to the level that BellSouth provides or is required to provide by law and its own internal procedures.
2. BellSouth shall use its best efforts in working with AT&T to meet maintenance standards for all Local Services and Unbundled Network Elements and Combinations ordered under this Agreement, as specified in Section 8 of this Attachment. Where applicable to a particular Local Service, an Unbundled Network Element, or Combination, such maintenance standards shall include, without limitation, standards for testing, network management, call gapping, and notification of upgrades as they become available.
3. BellSouth shall cooperate with AT&T through a joint implementation team to establish an Electronic Interface for gateway or automated access by AT&T to BellSouth's maintenance systems and databases in order to allow AT&T maintenance personnel and customer service representatives to perform the following functions for AT&T Customers: (i) enter a new customer trouble ticket into the BellSouth maintenance system for an AT&T Customer; (ii) retrieve and track current status on all AT&T Customer repair tickets; (iii) receive "estimated time to repair" ("ETTR") on a real-time basis; (iv) initiate a technician dispatch; (v) receive timely notification in the event a repair person is unable to be present for, or anticipates missing, a scheduled repair opportunity; (vi) retrieve all applicable time and material charges at the time of ticket closure (itemized by time spent, price of materials used, procedures employed, amounts incurred in each such category, and total by customer, per event); and (vii) perform an electronic test at the time of ticket entry and provide test results to AT&T.
  - 3.1 BellSouth agrees to use its best efforts to develop and implement as soon as is practicable, but no later than the dates specified in Attachment 15, the electronic interface described above into BellSouth's systems in a manner to provide AT&T with the capability to provide an AT&T Customer the same maintenance service as BellSouth provides its own customers.
    - 3.1.1 Until an electronic interface is developed for entering repair tickets directly into BellSouth's maintenance system, BellSouth agrees that AT&T will report troubles directly to the appropriate BellSouth Repair Center.



FL6/10/97

- 3.1.2 DELETED
- 3.1.3 DELETED
- 3.1.4 Until an electronic interface exists, BellSouth will provide AT&T the ability to obtain the status on open maintenance trouble tickets via telephone.
- 3.1.5 Until an electronic interface exists, BellSouth agrees that AT&T may transmit repair calls to BellSouth's repair bureau and request dispatching a BellSouth technician to an AT&T customer's premises by telephone. In this interim process, the following standards will apply:
- 3.1.5.1 BellSouth agrees to provide the status upon AT&T's request, in an expedient manner. Standards for this status notification will be documented on the Workcenter Interface Agreement.
- 3.1.5.2 Upon request by AT&T, BellSouth agrees to provide the status on open maintenance trouble tickets proactively for AT&T's large business customers. On a non-discriminatory basis as to other BellSouth customers, BellSouth agrees that AT&T's large business customers' trouble reports will be given priority handling as is done with BellSouth's large business customers' trouble reports. This priority handling shall include immediate expedite and proactive escalation procedures. Guidelines for status and priority handling for large business customers will be documented in the workcenter interface agreement.
- 3.1.6 Until an electronic interface exists, BellSouth agrees that AT&T may call BellSouth to verify central office features and functions when reporting trouble. BellSouth agrees to work with AT&T on the initial trouble report to isolate the cause of the trouble and where possible, resolve the feature/function related trouble at that time.
- 3.1.7 BellSouth agrees to advise AT&T of any central office failure that is known at the time of any inquiry or trouble report. Working with AT&T, BellSouth agrees to use its best efforts to implement a process by March 31, 1997, to provide AT&T with notification of switch failures.
- 3.1.8 BellSouth agrees to provide an Estimated Time To Repair (ETTR) on all trouble reports, an appointment time or a commitment time, as appropriate.
- 3.1.9 Prior to AT&T sending BellSouth the first service order, BellSouth agrees to develop, with AT&T's cooperation, a mutually acceptable Workcenter Interface Agreement to document the methods and procedures for the interim interface.

JB

- 3.1.10 Prior to AT&T sending BellSouth the first service order, AT&T shall review the procedures that all BellSouth service technicians who provide repair service for AT&T Customers shall follow in all their communications with AT&T Customers. At a minimum, the aforementioned procedures shall assume that (1) BellSouth technicians shall provide repair service that is at least equal in quality to that provided to BellSouth customers; (2) trouble calls from AT&T Customers shall receive response time priority that is at least equal to that of BellSouth customers and shall be handled on a "first come first served" basis regardless of whether the customer is an AT&T Customer or a BellSouth customer.
4. BellSouth shall provide AT&T with the same scheduled and non-scheduled maintenance, including, without limitation, required and recommended maintenance intervals and procedures, for all Local Services, Unbundled Network Elements and Combinations provided to AT&T under this Agreement that it currently provides for the maintenance of its own network. Procedures for scheduled and non-scheduled maintenance will be documented in the Workcenter Interface Agreement.
- 4.1 BellSouth shall negotiate the release (authorization to interrupt service) of any Unbundled Network Elements or Large Business customers' service with AT&T prior to any scheduled maintenance activity which may impact those services.
- 4.2 For services provided through resale, BellSouth agrees to provide AT&T with scheduled maintenance for residence and small business customers, consisting of cable throws performed with test sets which prevent the customers from being interrupted during the activity. BellSouth shall monitor individual cutover work to insure that the service is not in use prior to a service cut. Central Office conversions shall be publicized through the media and will occur after midnight and before 4 a.m., unless AT&T is provided with written notification.
5. **DELETED**
6. **DELETED**
7. On misdirected calls BellSouth and AT&T shall advise customers to contact their Local Service Provider and will provide the customer with the Local Service Provider contact number.
8. BellSouth repair bureau shall conform to the following performance and service quality standards when providing repair and maintenance to AT&T and AT&T Customers under this Agreement:

  
FL6/10/97

- 8.1 if service is provided to AT&T Customers before an Electronic interface is established between AT&T and BellSouth, AT&T will transmit repair calls to the BellSouth repair bureau by telephone. In such event, the speed of answer time for AT&T will be at least equal to that for BellSouth Customers.
- 8.2 The BellSouth repair bureau including the Electronic Interface to be established pursuant to Section 3 of this Attachment, shall be on-line and operational twenty-four (24) hours per day, seven (7) days per week except for scheduled electronic interface downtime.
- 8.3 **DELETED**
- 8.4 **DELETED**
- 8.5 BellSouth's response time to emergency network outages shall be as set forth in the Disaster Recovery Plan. Notwithstanding the above, BellSouth's response time shall be at least equal to the response time BellSouth provides to itself and BellSouth's Customers.
- 8.6 **DELETED**
- 8.7 **DELETED**
- 8.8 **DELETED**
- 8.9 **DELETED**
- 8.10 BellSouth's repair service centers supporting AT&T as a Reseller will be the same centers that support BellSouth's end users and, therefore, AT&T will be supported by BellSouth personnel with the same level of training or certification as those supporting BellSouth's end-users. The AT&T ACAC, which supports unbundled network elements excluding BellSouth's port, is certified.
- 8.11 BellSouth will provide the telephone number for the duty supervisor in the repair center as the first point of escalation. In the event that further escalation is necessary, that supervisor will be responsible for contacting the next escalation on behalf of AT&T. At each escalation hand off, BellSouth will provide AT&T with a proactive status report. This person is also responsible for providing the name and telephone number of the next level in the escalation procedure, if requested.
- 8.12 **DELETED**
- 8.13 Maintenance charges for premises visits by BellSouth technicians shall be billed by AT&T to its Customer, and not by BellSouth. The BellSouth technician shall, (i) contact AT&T for authorization, (ii) provide an estimate of

*UB*

technician shall, (i) contact AT&T for authorization, (ii) provide an estimate of time and materials required, (iii) quote time and charges at the completion of the repair visit, (iv) notify AT&T if a subsequent visit is required. BellSouth will bill maintenance charges for premises visits to AT&T.

- 8.4 When maintenance charges are incurred during premises visits, the BellSouth technician shall present the Customer with a form that is consistent with Section 19 of the General Terms and Conditions of this Agreement detailing the time spent, the materials used, and an indication that the trouble has either been resolved, or that additional work will be necessary, in which case BellSouth technician shall make an additional appointment with the Customer. The BellSouth technician shall obtain the Customer's signature upon said form, and then use the signed form to input maintenance charges into BellSouth's database (accessible by way of the Electronic Interface established pursuant to Section 3 preceding).



TABLE OF CONTENTS

CONNECTIVITY BILLING AND RECORDING .....	1
1. GENERAL .....	1
2. BILLABLE INFORMATION AND CHARGES .....	4
3. MEET POINT BILLING .....	3
4. COLLOCATION .....	5
5. MUTUAL COMPENSATION .....	5
6. LOCAL NUMBER PORTABILITY .....	6
7. ISSUANCE OF BILLS - GENERAL .....	6
8. ELECTRONIC TRANSMISSIONS .....	8
9. TAPE OR PAPER TRANSMISSIONS .....	10
10. TESTING REQUIREMENTS .....	19
11. ADDITIONAL REQUIREMENTS .....	19
12. BILL ACCURACY CERTIFICATION .....	20
13. PAYMENT OF CHARGES .....	20
14. BILLING DISPUTES .....	21
15. LATE PAYMENT CHARGES .....	22
16. ADJUSTMENTS .....	22
17. RECORDING OF CALL INFORMATION .....	23
18. DELETED .....	23

## CONNECTIVITY BILLING AND RECORDING

### 1. General

This Section describes the requirements for BellSouth to bill and record all charges AT&T incurs for purchasing Local Services for resale and for Network Elements and Combinations, and to provide Meet Point Billing and Mutual Compensation.

### 2. Billable Information And Charges

BellSouth will bill and record in accordance with this Agreement those charges AT&T incurs as a result of AT&T purchasing from BellSouth Network Elements, Combinations, and Local Services, as set forth in this Agreement. BellSouth will bill charges for interconnection and charges for unbundled network elements, with the exception of the unbundled ports or unbundled port/loop combinations through CABS or in the CABS format. BellSouth will format each bill in CABS or in CABS format in accordance with CABS standards and specifications. As an interim process, the Parties have agreed to specific elements of CRIS billing. Those elements are named in Exhibit A attached hereto and incorporated herein by this reference. Each bill shall set forth the quantity and description of each such Network Element, Combination, or Local Service provided and billed to AT&T. All charges billed to AT&T will indicate the state from which such charges were incurred except in cross boundary state situations. A listing of the current cross state boundary exchanges has been provided to AT&T.

- 2.1.1 As an interim process, BellSouth will provide AT&T with bills in the CRIS/CLUB format via paper or other mutually agreed upon medium for those services purchased by AT&T for resale and for the billing of the unbundled port and loop/port combination in accordance with the specifications and requirements set forth in Exhibit A to this Attachment for no more than one hundred and eighty (180) days after the Effective Date of this Agreement. After that time, BellSouth shall provide bills using only CABS or the CABS format as outlined in this Agreement.

AT&T and BellSouth will work together in a cooperative effort with the OBF to establish a single billing system and applicable standards. Once the billing standards/system are defined, BellSouth and AT&T will mutually agree when the standards/system will be implemented.

UB  
FL6/10/97

- 2.2 BellSouth shall provide AT&T a monthly bill that includes all charges incurred by and credits and/or adjustments due to AT&T for those Network Elements Combination thereof, or Local Services ordered, established, utilized, discontinued or performed pursuant to this Agreement. Each bill provided by BellSouth to AT&T shall include: (1) all non-usage sensitive charges incurred for the period beginning with the day after the current bill date and extending to, and including, the next bill date; (2) any known unbilled non-usage sensitive charges for prior periods; (3) unbilled usage sensitive charges for the period beginning with the last bill date and extending through the current bill date; (4) any known unbilled usage sensitive charges for prior periods, and (5) any known unbilled adjustments.
- 2.3 The Bill Date, as defined herein, must be present on each bill transmitted by BellSouth to AT&T, must be a valid calendar date, and not more than one (1) year old. Bills shall not be rendered for any charges which are incurred under this Agreement on or before one (1) year preceding the Bill Date, except as otherwise permitted by law. In addition, on each bill where "Jurisdiction" is identified, local and local toll charges shall be identified as "Local" and not as interstate, interstate/interLATA, intrastate, or intrastate/intraLATA. BellSouth will provide from and through dates for charges rendered on all bills. In addition, BellSouth will separately identify business charges from residence charges, as appropriate.
- 2.4 BellSouth shall bill AT&T for each Network Element, combination thereof, or Local Service, supplied by BellSouth to AT&T pursuant to this Agreement at the rates set forth in this Agreement. BellSouth will bill AT&T based on the actual charges incurred, provided, however, for those usage based charges where actual charge information is not determinable by BellSouth because the jurisdiction (i.e., interstate, interstate/interLATA, intrastate, intrastate/intraLATA, local) of the traffic is unidentifiable, the Parties will jointly develop a process to determine the appropriate charges. Measurement of usage-based charges shall be in actual conversation seconds. The total conversation seconds per chargeable traffic types will be totaled for the entire monthly bill cycle and then rounded to the next whole minute.
- 2.5 **DELETED**
- 2.6 Each Party shall provide the other Party, at no additional charge, a contact person for the handling of any billing questions or problems that may arise during the implementation and performance of the terms and conditions of this Attachment. Billing questions subsequent to implementation will be directed to the billing specialist in the Local Carrier Service Center (LCSC) for

WB

CRIS billing and through the interexchange Carrier Service Center (CSC) for CABS related issues.

### **3 Meet Point Billing**

- 3.1 Where appropriate for unbundled network elements, AT&T and BellSouth will establish meet-point billing ("MPB") arrangements in accordance with the Meet-Point Billing guidelines adopted by and contained in the OBF's MECAB and MECOD documents, except as modified herein. Both Parties will use their best reasonable efforts, individually and collectively, to maintain provisions in their respective federal and state access tariffs, and/or provisions within the National Exchange Carrier Association ("NECA") Tariff No. 4, or any successor tariff to reflect the MPB arrangements identified in this Agreement, in MECAB and in MECOD.
- 3.2 AT&T and BellSouth will implement the "Multiple Bill/Multiple Tariff" option in order to bill any interexchange carrier ("IXC") for that portion of the network elements provided by AT&T or BellSouth. For all traffic carried over the MPB arrangement, AT&T and BellSouth shall bill each other all applicable elements at the rates specified in this Agreement.
- 3.3 BellSouth shall provide to AT&T the billing name, billing address, and carrier identification code ("CIC") of the IXCs that may utilize any portion of AT&T's network in an AT&T/BellSouth MPB arrangement in order to comply with the MPB Notification process as outlined in the MECAB document. Such information shall be provided to AT&T in the format and via the medium that the Parties agree. If BellSouth does not have a CIC for any IXC that will utilize a portion of AT&T's network in an AT&T/BellSouth MPB arrangement, and for whom BellSouth must supply to AT&T MPB billing information, BellSouth agrees that it will assist such carrier in obtaining a CIC expeditiously. Until such carrier has obtained a CIC, BellSouth will submit BellSouth's CIC on those MPB records provided to AT&T for MPB. BellSouth understands and agrees that it will be solely responsible for obtaining any reimbursements from those carriers who have utilized the jointly provided networks of BellSouth and AT&T.
- 3.4 BellSouth and AT&T agree that in an MPB arrangement where one Party provides local transport and the other Party provides the end office switching, the Party who provides the end office switching is entitled to bill any residual interconnection charges ("RIC") and common carrier line ("CCL") charges associated with the traffic. The Parties further agree that in those MPB situations where one Party sub-tends the other Party's access tandem, the

Party providing the access tandem is only entitled to bill the access tandem fee and any associated local transport charges. The Parties also agree that the Party who provides the end office switching is entitled to bill end office switching fees, local transport charges, RIC and CCL charges, as appropriate, and such other applicable charges.

- 3.5 BellSouth and AT&T will record and transmit MPB information in accordance with the standards and in the format set forth in this Attachment. BellSouth and AT&T will coordinate and exchange the billing account reference ("BAR") and billing account cross reference ("BACR") numbers for the MPB arrangements described in this Agreement. Each Party will notify the other if the level of billing or other BAR/BACR elements change, resulting in a new BAR/BACR number.
- 3.6 If MPB data is not processed and delivered by either BellSouth or AT&T and sent to the other Party within ten (10) days of their recording and in turn such Party is unable to bill the IXC for the appropriate charges, the Party who failed to deliver the data will be held liable for the amount of the unbillable charges. When the subsequent billing company ("SBC") is the recording company, they shall provide the initial billing company ("IBC") the detail billing records on a weekly basis (within five (5) days). If the IBC is the recording company, detail billing record exchange is not necessary. The IBC shall provide the SBC the summary billing records within ten (10) days from the IBC bill date. The Party who failed to deliver the data will be held liable for the amount of the unbillable charges.
- 3.7 If MPB data is not submitted within ten (10) days of their recording or is not in the proper format as set forth in this Agreement, and if as a result the other Party is delayed in billing the IXC for the appropriate charges it incurs, the delaying Party shall pay the other Party a late MPB data delivery charge which will be the total amount of the delayed charges times the highest interest rate (in decimal value) which may be levied by law for commercial transactions, compounded daily for the number of days from the date the MPB charges should have been received to and including the date the MPB charge information is actually received.
- 3.8 Errors in MPB data exchanged by the Parties may be discovered by AT&T, BellSouth or the billable IXC. Both AT&T and BellSouth agree to provide the other Party with notification of any discovered errors within two (2) business days of the discovery. The other Party shall correct the error within eight (8) business days of notification and resubmit the data. In the event the errors cannot be corrected within the time period specified above, the erroneous data shall be considered lost. If MPB data is lost due to incorrectable errors



or otherwise, the Parties shall follow the procedures set forth in the Customer Billing Data Attachment of this Agreement and compensate the other for the lost MPB billing data.

- 3.9 In the event AT&T purchases from BellSouth Network Elements, or Combination thereof, in a LATA other than the LATA to or from which the MPB services are homed and in which BellSouth operates an access tandem, BellSouth shall, except in instances of capacity limitations, permit and enable AT&T to sub-tend the BellSouth access tandem switch(es) nearest to the AT&T rating point(s) associated with the NPA-NXX(s) to/from which the MPB services are homed. In instances of capacity limitation at a given access tandem switch, AT&T shall be allowed to sub-tend the next-nearest BellSouth access tandem switch in which sufficient capacity is available. The MPB percentages for each new rating point/access tandem pair shall be calculated in accordance with MECAB and MECOD.
- 3.10 Neither AT&T nor BellSouth will charge the other for the services rendered, or for information provided pursuant to Section 4 of this Attachment except those MPB charges specifically set forth herein. Both Parties will provide the other a single point of contact to handle any MPB questions.

#### 4. Collocation

When AT&T collocates with BellSouth in BellSouth's facility as described in this Agreement, capital expenditures (e.g., costs associated with building the "cage"), shall not be included in the bill provided to AT&T pursuant to this Attachment. All such capital expenses shall be given a unique BAN (as defined in Section 7, below) and invoice number. All invoices for capital expenses shall be sent to the location specified by AT&T for payment. All other non-capital recurring collocation expenses shall be billed to AT&T in accordance with this Agreement. The CABS Billing Output Specifications ("BOS") documents provide the guidelines on how to bill the charges associated with collocation. The bill label for those collocation charges shall be entitled "Expanded Interconnection Service." For those nonmechanized bills, the bill label for non-capital recurring collocation expenses shall be entitled "Collocation".

#### 5. Mutual Compensation

- 5.1 The Parties shall bill each other reciprocal compensation in accordance with the standards set forth in this Agreement for Local Traffic terminated to the other Party's customer. Such Local Traffic shall be recorded and transmitted to AT&T and BellSouth in accordance with this Attachment. When an AT&T

  
FL4/2/97

Customer originates traffic and AT&T sends it to BellSouth for termination. AT&T will determine whether the traffic is local or intraLATA toll. When a BellSouth Customer originates traffic and BellSouth sends it to AT&T for termination, BellSouth will determine whether the traffic is local or intraLATA toll. Each Party will provide the other with information that will allow it to distinguish local from intraLATA toll traffic. At a minimum, each Party shall utilize NXXs in such a way that the other Party shall be able to distinguish local from intraLATA toll traffic. When AT&T interconnects with BellSouth's network for the purpose of completing local and intraLATA toll traffic, AT&T will, at its option, interconnect at either the tandem or end office switch to complete such calls paying local interconnection rates for its customers' local calls and switched access rates for its customers' intraLATA toll calls. Such interconnection will be ordered as needed by AT&T to deliver such local and intraLATA toll calls. Further, the Local Traffic exchanged pursuant to this Attachment shall be measured in billing minutes of use and shall be in actual conversation seconds. The total conversation seconds per chargeable traffic type will be totaled for the entire monthly billing cycle and then rounded to the next whole conversation minute. Reciprocal compensation for the termination of this Local Traffic shall be in accordance with Part IV to this Agreement.

**6. Local Number Portability**

**6.1 DELETED**

**6.2** When an IXC terminates an interLATA or IntraLATA toll call to an AT&T local exchange customer whose telephone number has been ported from BellSouth, the Parties agree that AT&T shall receive those IXC access charges associated with end office switching, local transport, RIC and CCL, as appropriate. BellSouth shall receive any access tandem fees, dedicated and common transport charges, to the extent provided by BellSouth, and any INP fees (i.e., such as RCF charges) set forth in this Agreement. When a call for which access charges are not applicable is terminated to an AT&T local exchange customer whose telephone number has been ported from BellSouth, and is terminated on AT&T's own switch, the Parties agree that the mutual compensation arrangements described in this Agreement shall apply.

**7. Issuance of Bills - General**

**7.1** BellSouth and AT&T will issue all bills in accordance with the terms and conditions set forth in this Section. BellSouth and AT&T will establish

monthly billing dates ("Bill Date") for each Billing Account Number ("BAN") as further defined in the CABS document or CRIS elements set forth in Exhibit A as appropriate. On bills BellSouth renders to AT&T, BANs shall be 13 character alpha/numeric and there shall only be one BAN per Revenue Accounting Office ("RAO"). The Bill Date shall be the same day month to month for all BANs, except that the 4<sup>th</sup>, 7<sup>th</sup> or 13<sup>th</sup> of each month will not be used as a Bill Date for bills BellSouth renders to AT&T. AT&T will provide one (1) BAN per state and the bill date will be the same day month to month for all BANs. Each BAN shall remain constant from month to month, unless changed as agreed to by the Parties. Each Party shall provide the other Party at least thirty (30) calendar days written notice prior to changing, adding or deleting a BAN. The Parties will provide one billing invoice associated with each BAN. Each invoice must contain an invoice number (which will vary from month to month). The bill date is the only varying invoice number available on the Resale bill. On each bill associated with a BAN, the appropriate invoice number and the charges contained on such invoice must be reflected. All bills must be received by the other Party no later than ten (10) calendar days from Bill Date and at least twenty (20) calendar days prior to the payment due date (as described in this Attachment), whichever is earlier. Any bill received on a Saturday, Sunday or a day designated as a holiday by the Chase Manhattan Bank of New York (or such other bank as AT&T shall specify) will be deemed received the next business day. If either Party fails to receive billing data and information within the time period specified above, the payment due date will be extended by the number of days the bill is late.

- 7.2 BellSouth and AT&T shall issue all CABS bills or bills in CABS format containing such billing data and information in accordance with CABS Version 26.0, Issue 4, or such later versions of CABS as are published by BellCore, or its successor, except that if the Parties enter into a meet-point billing arrangement, such billing data and information shall also conform to the standards set forth in the MECAB document, or such later versions as are adopted by BellCore, or its successor. To the extent that there are no CABS or MECAB standards governing the formatting of certain data, such data shall be issued in the format specified by AT&T. Consistent with Section 2.1.1 of this Attachment 6, BellSouth may issue AT&T Resale and unbundled port Connectivity bills in CRIS/CLUB format as provided herein for no more than one hundred eighty (180) days after the Effective Date of this Agreement.
- 7.3 Within thirty (30) days of finalizing the chosen billing media, each Party will provide the other Party written notice of which bills are to be deemed the official bills to assist the Parties in resolving any conflicts that may arise between the official bills and other bills received via a different media which



purportedly contain the same charges as are on the official bill. If either Party requests an additional copy(ies) of a bill, such Party shall pay the other Party a reasonable fee per additional bill copy, unless such copy was requested due to errors, omissions, or corrections or the failure of the transmission to comply with the specifications set forth in this Agreement.

- 7.4 When sending bills via electronic transmission, to avoid transmission failures or the receipt of billing information that cannot be processed, the Parties shall provide each other with their respective process specifications. Each Party shall comply with the mutually acceptable billing processing specifications of the other. AT&T and BellSouth shall provide each other reasonable notice if a billing transmission is received that does not meet such Party's specifications or that such Party cannot process. Such transmission shall be corrected and resubmitted to the other Party, at the resubmitting Party's sole expense, in a form that can be processed. The payment due date for such resubmitted transmissions will be twenty (20) days from the date that the transmission is received in a form that can be processed and that meets the specifications set forth in this Attachment.

## 8. Electronic Transmissions

- 8.1 BellSouth and AT&T agree that each Party will transmit billing information and data in the appropriate CABS format electronically via CONNECT:Direct (formerly known as Network Data Mover) to the other Party at the location specified by such Party. The Parties agree that a T1.5 or 56kb circuit to Gateway for CONNECT:Direct is required. AT&T data centers will be responsible for originating the calls for data transmission via switched 56kb or T1.5 lines. If BellSouth has an established CONNECT:Direct link with AT&T, that link can be used for data transmission if the location and applications are the same for the existing link. Otherwise, a new link for data transmission must be established. BellSouth must provide AT&T/Alpharetta its CONNECT:Direct Node ID and corresponding VTAM APPL ID before the first transmission of data via CONNECT:Direct. AT&T's CONNECT:Direct Node ID is "NDMATTA4" and VTAM APPL ID is "NDMATTA4" and must be included in BellSouth's CONNECT:Direct software. AT&T will supply to BellSouth its RACF ID and password before the first transmission of data via CONNECT:Direct. Any changes to either Party's CONNECT:Direct Node ID must be sent to the other Party no later than twenty-one (21) calendar days before the changes take effect.
- 8.2 The following dataset format shall be used as applicable for those charges transmitted via CONNECT:Direct in CABS format:



FL4/2/97

Production Dataset

AF25.AXXXXYYY.AZZZ.DDDEE	Production Dataset Name
AF25 =	Job Naming Convention
AXXXX =	Numeric Company Code
YYY =	LEC Remote
AZZZ =	RAO (Revenue Accounting Office)
DDD =	BDT (Billing Data Tape with or without CSR)  Or CSR (Customer Service Record)
EE =	01 thru 31 (Bill Period) (optional)  or GA (US Postal-State Code)

Test Dataset

AF25.ATEST.AXXXX.DDD	Test Dataset Name
AF25.ATEST =	Job Naming Convention
AXXXX =	Numeric Company Code
DDD =	BDT (Billing Data Tape with or without CSR)  Or CSR (Customer Service Record)

*UB*  
FL4/2/97

8 3 DELETED

9 **Tape or Paper Transmissions**

9 1 In the event either Party does not temporarily have the ability to send or receive data via CONNECT:Direct, that Party will transmit billing information to the other party via magnetic tape or paper, as agreed to by AT&T and BellSouth. Billing information and data contained on magnetic tapes or paper for payment shall be sent to the Parties at the following locations. The Parties acknowledge that all tapes transmitted to the other Party via U.S. Mail or Overnight Delivery and which contain billing data will not be returned to the sending Party.

**TO AT&T:**

<p><b>Tape Transmissions via U.S. Mail:</b></p>	<p><b>AT&amp;T</b> 300 North Point Parkway FLOC 217M01 Alpharetta, Georgia 30202 Attn: Access Bill Coordinator</p>
<p><b>Tape Transmissions via Overnight Delivery:</b></p>	<p><b>AT&amp;T</b> 500 North Point Parkway FLOC B1404 Alpharetta, Georgia 30302 Attn: Access Bill Coordinator</p>

<p><b>Paper Transmissions via U.S. Mail:</b></p>	<p><b>AT&amp;T</b> Caller Service 8908  Alpharetta, Georgia 30202 Attn: Access Bill Coordinator</p>
--	---

*LB*

Paper Transmissions via Overnight Delivery:	AT&T 500 North Point Parkway FLOC B1404 Alpharetta, Georgia 30302 Attn: Access Bill Coordinator
---	---

**TO BellSouth:**

Tape Transmissions:	-  Attn:
Paper Transmissions:	Attn:

- 9.2 Each Party will adhere to the tape packaging requirements set forth in this subsection. Where magnetic tape shipping containers are transported in freight compartments, adequate magnetic field protection shall be provided by keeping a typical 6-inch distance from any magnetic field generating device (except a magnetron-tape device). The Parties agree that they will only use those shipping containers that contain internal insulation to prevent damage. Each Party will clearly mark on the outside of each shipping container its name, contact and return address. Each Party further agrees that it will not ship any Connectivity Billing tapes in tape canisters.
- 9.3 All billing data transmitted via tape must be provided on a cartridge (cassette) tape and must be of high quality, conform to the Parties' record and label standards, 9-track, odd parity, 6250 BPI, group coded recording mode and extended binary-coded decimal interchange code ("EBCDIC"). Each reel of tape must be 100% tested at 20% or better "clipping" level with full width certification and permanent error free at final inspection. AT&T reserves the

*l/02*  
FL4/2/97

right to destroy a tape that has been determined to have unrecoverable errors. AT&T also reserves the right to replace a tape with one of equal or better quality.

- 9.4 Billing data tapes shall have the following record and label standards. The dataset serial number on the first header record of an IBM standard tape label also shall have the following format.

	CABS BOS	
Record Length	225 bytes (fixed length)	
Blocking factor	84 records per block	
Block size	18,900 bytes per block	
Labels	Standard IBM Operating System	

- 9.5 A single 6-digit serial number must appear on the external (flat) surface of the tape for visual identification. This number shall also appear in the "dataset serial number field" of the first header record of the IBM standard tape label. This serial number shall consist of the character "V" followed by the reporting location's four digit Originating Company Code and a numeric character chosen by the sending company. The external and internal label shall be the same. The dataset name shall appear on the flat side of the reel and also in the "data set name field" on the first header record of the IBM standard tape label. BellSouth's name, address, and contact shall appear on the flat side of the cartridge or reel.

- 9.6 Tape labels shall conform to IBM OS/VS Operating System Standards contained in the IBM Standard Labels Manual (GC26-3795-3). IBM standard labels are 80-character records recorded in EBCDIC, odd parity. The first four characters identify the labels:

Volume 1	Volume label
HDR1 and HDR2	Data set header labels
EOV1 and EOV2	Data set trailer labels (end-of-volume for multi-reel files)

**EOF1 and EOF2 Data set trailer labels (end-of-data-set)**

The HDR1, EOVS1, and EOF1 labels use the same format and the HDR2, EOVS2, and EOF2 labels use the same format.

9.7 The Standard Volume Label Format (Vol. 1) is described below:

FIELD NAME	CONTENTS
Label Identifier (3 bytes)	The characters "VOL" identify this label as a volume label.
Label Number (1 byte)	The relative position of this label within a set of labels of the same type; it is always a 1 for the IBM standard volume label.
Volume Serial Number (6 bytes)	A unique identification code, normally numeric characters (000001-999999), but may be alpha-numeric; if fewer than 6 characters, must be left-justified. This same code should also appear on the external (flat) surface of the volume for visual identification.
Reserved (1 byte)	Reserved for future use - should be recorded as blanks.
VTOC Pointer (10 bytes)	Direct-access volumes only. This field is not used for tape volumes and should be recorded as blanks.
Reserved (10 bytes)	Reserved for future use - should be recorded as blanks.
Owner Name and Address Code (10 bytes)	Indicates a specific customer, person, installation, department, etc., to which the volume belongs. Any code or name is acceptable.
Reserved (29 bytes)	Reserved for future use - should be recorded as blanks.

9.8 The IBM Standard Dataset Label 1 Format (HDR1, EOVS1, EOF1) is described below:

FIELD NAME	CONTENTS
<p>Label Identifier (3 bytes)</p>	<p>Three characters that identify the label are:</p> <p>HDR Header label (at the beginning of a dataset)</p> <p>EOV Trailer label (at the end of a tape volume, when the dataset continues on another volume)</p> <p>EOF Trailer label (at the end of a dataset).</p>
<p>Label Number (1 byte)</p>	<p>The relative position of this label within a set of labels of the same type; it is always a 1 for dataset label 1.</p>
<p>Dataset Identifier (17 bytes)</p>	<p>The rightmost 17 bytes of the dataset name (includes GnnnnVnnr if the dataset is part of a generation data group). If the dataset name is less than 17 bytes, it is left-justified and the remainder of this field is padded with blanks.</p>
<p>Dataset Serial Number (6 bytes)</p>	<p>The volume serial number of the tape volume containing the dataset. For multi-volume datasets, this field contains the serial number of the first volume of the aggregate created at the same time. The serial number can be any 6 alphanumeric characters, normally numeric (000001-999999). If the number of characters is fewer than 6 characters, the code must be left-justified and followed by blanks.</p>
<p>Volume Sequence Number (4 bytes)</p>	<p>A number (0001-9999) that indicates the order of volume within the multi-volume group created at the same time. This number is always 0001 for a single volume dataset.</p>
<p>Dataset Sequence Number (4 bytes)</p>	<p>A number (0001-9999) that indicates the relative position of the dataset within a multi-dataset group. This number is always 0001 for a single dataset organization.</p>
<p>Generation Number (4 bytes)</p>	<p>If the dataset is part of a generation data group, this field contains a number from 0001 to 9999 indicating the absolute generation number (the first generation is recorded as 0001). If the dataset is not part of a generation data group, this field contains blanks.</p>

*LP*

FIELD NAME	CONTENTS
Version Number Of Generation (2 bytes)	If the dataset is part of a generation data group, this field a number from 00 to 99 indicating the version number of the generation (the first version is recorded as 00). If the dataset is not part of a generation data group, this field contains blanks.
Creation Date (6 bytes)	Year and day of the year when the dataset was created. The date is shown in the format byydd where:  b = blank yy = year(00-99) ddd = day(001-366)
Expiration Date (6 bytes)	Year and day of the year when the dataset may be scratched or overwritten. The data is shown in the format byydd where:  b = blank yy = year (00-99) ddd = day (001-366)
Dataset Security (1 byte)	A code number indicating the security status of the dataset is as follows:  0 No password protection  1 Password protection. Additional identification of the dataset is required before it can be read, written, or deleted (ignored if volume is RACF-defined)  3 Password protection. Additional identification of the dataset is required before it can be read, written, or deleted (ignored if volume is RACF-defined).
Block Count (6 bytes)	This field in the trailer label shows the number of data blocks in the dataset on the current volume. This field in the header label is always zeros (000000).

  
FL4/2/97



FIELD NAME	CONTENTS
System Code (13 bytes)	Unique code that identifies the system.
Reserved (7 bytes)	Reserved for future use - should be recorded as blanks.

9.9 The IBM Standard Dataset Label 2 Format (HDR2, EOVS, EOF2) always follows dataset label 1 and contains additional information about the associated dataset as described below:

Label Identifier (3 bytes)	<p>Three characters that identify the label are as follows:</p> <p>HDR Header label (at the beginning of a dataset)</p> <p>EOV Trailer label (at the end of a tape volume, when the dataset continues on another volume)</p> <p>EOF Trailer label (at the end of a dataset).</p>
Label Number (1 byte)	The relative position of this label within a set of labels of the same type; it is always a 2 for dataset label 2.
Record Format (1 byte)	<p>An alphabetic character that indicates the format of records in the associated dataset as follows:</p> <p>F Fixed length</p> <p>V Variable length</p> <p>U Undefined length.</p>

<p><b>Block Length (5 bytes)</b></p>	<p>A number up to 32760 that indicates the block length, in bytes. Interpretation of the number depends on the following associated record format in Field 3:</p> <p>Format F - Block length (must be a multiple of the logical record length in Field 5)</p> <p>Format V - Maximum block length (including the 4 byte length indicator in the block)</p> <p>Format U - Maximum block length.</p>						
<p><b>Record Length (5 bytes)</b></p>	<p>A number that indicates the record length, in bytes. Interpretation of the number depends on the following associated record format in Field 3:</p> <p>Format F - Logical record length</p> <p>Format V - Maximum logical record length (including the 4 byte length indicator in the records)</p> <p>Format U - Zeros.</p>						
<p><b>Tape Density (1 byte)</b></p>	<p>A code indicating the record density of the tape, as follows:</p> <p><b>Recording Density</b></p> <table data-bbox="690 1255 1177 1438"> <thead> <tr> <th>DEN Value</th> <th>9-Track Tape</th> </tr> </thead> <tbody> <tr> <td>3</td> <td>1600 (PE)</td> </tr> <tr> <td>4</td> <td>6250 (GCR)</td> </tr> </tbody> </table> <p>PE - is for phase encoded mode</p> <p>GCR - is for group coded recording mode.</p>	DEN Value	9-Track Tape	3	1600 (PE)	4	6250 (GCR)
DEN Value	9-Track Tape						
3	1600 (PE)						
4	6250 (GCR)						
<p><b>Dataset Position (1 byte)</b></p>	<p>A code, indicating a volume switch, is as follows:</p> <p>0 - No volume switch has occurred</p> <p>1 - A volume switch previously occurred.</p>						

  
FL4/2/97

<p><b>Job/Job Step</b> (17 bytes)</p>	<p>Identification of the job and job step that created the dataset. The first 8 bytes contain the name of the job, the ninth byte is a slash (/), and the final 8 bytes contain the name of the job step.</p>
<p><b>Tape Recording Technique</b> (2 bytes)</p>	<p>A code or blanks indicating the tape recording technique used. This field is recorded as blanks for 9-track tape. The only technique available for 9-track tape is odd parity and no translation.</p>
<p><b>Control Characters</b> (1 byte)</p>	<p>A code indicating whether a control character set was used to create the dataset and the type of control characters used:</p> <p>A Contains ASCII control characters</p> <p>M Contains machine control characters</p> <p>b Contains no control characters.</p>
<p><b>Reserved</b> (1 byte)</p>	<p>Reserved for future use - should be recorded as blanks.</p>
<p><b>Block Attribute</b> (1 byte)</p>	<p>A code indicating the block attribute used to create the dataset:</p> <p>B Blocked records</p> <p>S Spanned records</p> <p>R Blocked and spanned records</p> <p>b No blocked and no spanned records.</p>
<p><b>Reserved</b> (8 bytes)</p>	<p>Bytes 40-42 - reserved for future use - should be blanks. Bytes 43-47 - (3420 tape units only) serial number of creating tape unit. Blank for other units.</p>
<p><b>Checkpoint Dataset</b> (1 byte)</p>	<p>In VS2-Release 2, this byte contains the identifier character C if the dataset is a checkpoint dataset; the byte is blank if the dataset is not a check point dataset or in other releases of the VS systems.</p>
<p><b>Reserved</b> (32 bytes)</p>	<p>Reserved for future use - should be recorded as blanks.</p>

**10 Testing Requirements**

- 10.1 Within thirty (30) days of the execution of this Agreement, BellSouth shall send to AT&T bill data in the appropriate mechanized format (i.e. CABS or CRIS) for testing to ensure that bills can be processed and that bills comply with the requirements of this Attachment 6. After receipt of the test data from BellSouth, AT&T will notify BellSouth if the billing transmission meets AT&T's testing specifications. If the transmission fails to meet AT&T's testing specifications, BellSouth shall make the necessary corrections. At least three (3) sets of testing data must meet AT&T's testing specifications prior to BellSouth sending AT&T a mechanized production bill for the first time via electronic transmission or tape. Thereafter, BellSouth may begin sending AT&T mechanized production bills on the next Bill Date, or within ten (10) days, whichever is later.
- 10.2 At least thirty (30) days prior to changing mechanized formats (e.g., CABS), BellSouth shall send to AT&T bill data in the appropriate mechanized format for testing to ensure that the bills can be processed and that the bills comply with the requirements of this Attachment. BellSouth agrees that it will not send AT&T bill data in the new mechanized format until such bill data has met the testing specifications as set forth in this subsection.
- 10.3 BellSouth shall provide to AT&T's Company Manager, located at 500 North Point Parkway, FLOC B1104B, Alpharetta, Georgia 30302, BellSouth's originating or state level company code so that it may be added to AT&T's internal tables at least thirty (30) calendar days prior to testing or prior to a change in BellSouth's originating or state level company code.
- 10.4 During the testing period, BellSouth shall transmit to AT&T billing data and information via paper transmission, Test tapes shall be sent to AT&T at the following location:

<b>Test Tapes:</b>	<b>AT&amp;T</b> 500 North Point Parkway FLOC B1104B Alpharetta, Georgia 30302 Attn: Access Bill Testing Coordinator
--------------------	--

**11. Additional Requirements**

*LB*  
FL4/2/97

11.1 BellSouth agrees that if it transmits data to AT&T in a mechanized format, BellSouth will also comply with the following specifications which are not contained in CABS guidelines but which are necessary for AT&T to process billing information and data:

- The BAN shall not contain embedded spaces or low values.
- The Bill Date shall not contain spaces or non-numeric values
- Each bill must contain at least one detail record.
- Any "From" Date should be less than the associated "Thru" Date and neither date can contain spaces.
- The Invoice Number must not have embedded spaces or low values.

11.2 **DELETED**

12. **Bill Accuracy Certification**

Within 120 days of the execution of this Agreement, AT&T and BellSouth will agree upon a CRIS billing quality assurance program that will eliminate the need for post-billing reconciliation. Appropriate terms for access to any BellSouth documents, systems, records, and procedures for the billing, recording of charges will be part of that program. In the event the Parties are unable to reach agreement on such a program, the matter will be resolved pursuant to the disputes process provided in Attachment 1.

13. **Payment Of Charges**

13.1 Subject to the terms of this Agreement, AT&T and BellSouth will pay each other within thirty (30) calendar days from the Bill Date, or twenty (20) calendar days from the receipt of the bill, whichever is later. If the payment due date is a Sunday or is a Monday that has been designated a bank holiday by the Chase Manhattan Bank of New York (or such other bank as AT&T specifies), payment will be made the next business day. If the payment due date is a Saturday or is on a Tuesday, Wednesday, Thursday or Friday that has been designated a bank holiday by the Chase Manhattan Bank of New York (or such other bank as AT&T specifies), payment will be made on the preceding business day.

13.2 Payments shall be made in U.S. Dollars via electronic funds transfer ("EFT") to the other Party's bank account. At least thirty (30) days prior to the first transmission of billing data and information for payment, BellSouth and AT&T shall provide each other the name and address of its bank, its account and routing number and to whom billing payments should be made payable. If such banking information changes, each Party shall provide the other Party at least sixty (60) days written notice of the change and such notice shall include the new banking information. The Parties will render payment via

  
FL4/2/97

EFT. AT&T will provide BellSouth with one address to which such payments shall be rendered and BellSouth will provide to AT&T with only one address to which such payments shall be rendered. In the event AT&T receives multiple bills from BellSouth which are payable on the same date, AT&T may remit one payment for the sum of all bills payable to BellSouth's bank account specified in this subsection. Each Party shall provide the other Party with a contact person for the handling of billing payment questions or problems.

#### **14. Billing Disputes**

- 14.1 Each Party agrees to notify the other Party upon the discovery of a billing dispute. In the event of a billing dispute, the Parties will endeavor to resolve the dispute within sixty (60) calendar days of the Bill Date on which such disputed charges appear. Resolution of the dispute is expected to occur at the first level of management resulting in a recommendation for settlement of the dispute and closure of a specific billing period. The Parties shall replicate the bill closure procedures set forth in the Access Billing Supplier Quality Certification Operating Agreement. A mutually agreed upon escalation process similar to what is used for CABS billing will be established for the CRIS resale bill as part of the quality assurance program developed pursuant to Section 12 of this Attachment 6. In the interim, in the event of a billing dispute, the process described in Exhibit B to this Attachment shall be followed. Closure of a specific billing period will occur by joint agreement of the Parties whereby the Parties agree that such billing period is closed to any further analysis and financial transactions, except those resulting from an Audit as described in Section 11 of the General Terms and Conditions of this Agreement. Closure will take place within three (3) months of the Bill Date. The month being closed represents those charges that were billed or should have been billed by the respective Bill Date. If the issues are not resolved within the allotted time frame, the following resolution procedure will begin:**
- 14.1.1 If the dispute is not resolved within sixty (60) days of the Bill Date, the dispute will be escalated to the second level of management for each of the respective Parties for resolution. If the dispute is not resolved within ninety (90) days of the Bill Date, the dispute will be escalated to the third level of management for each of the respective Parties for resolution.**
- 14.1.2 If the dispute is not resolved within one hundred and twenty (120) days of the Bill Date, the dispute will be escalated to the fourth level of management for each of the respective Parties for resolution.**
- 14.1.3 If the dispute is not resolved within one hundred and fifty (150) days of the Bill Date, the dispute will be resolved in accordance with the procedures set**

forth in the Section 16 of the General Terms and Conditions of this Agreement and Attachment 1

- 14.2 If a Party disputes a charge and does not pay such charge by the payment due date, such charges shall be subject to late payment charges as set forth in the Late Payment Charges provision of this Attachment. If a Party disputes charges and the dispute is resolved in favor of such Party, the other Party shall credit the bill of the disputing Party for the amount of the disputed charges along with any late payment charges assessed no later than the second Bill Date after the resolution of the dispute. Accordingly, if a Party disputes charges and the dispute is resolved in favor of the other Party, the disputing Party shall pay the other Party the amount of the disputed charges and any associated late payment charges assessed no later than the second bill payment due date after the resolution of the dispute. In no event, however, shall any late payment charges be assessed on any previously assessed late payment charges.

15. **Late Payment Charges**

If either Party fails to remit payment for any charges described in this Attachment by the payment due date, or if a payment or any portion of a payment is received by either Party after the payment due date, or if a payment or any portion of a payment is received in funds which are not immediately available to the other Party, then a late payment penalty shall be assessed. The late payment charge shall be calculated based on the portion of the payment not received by the payment date times the lesser of (i) one and one-half percent (1 1/2%) per month or (ii) the highest interest rate (in decimal value) which may be charged by law for commercial transactions, compounded daily for the number of days from the payment date to and including the date that payment is actually made. In no event, however, shall interest be assessed on any previously assessed late payment charges.

16. **Adjustments**

Subject to the terms of this Attachment, BellSouth will reimburse AT&T for incorrect billing charges; overcharges; Local Services Elements, or any Combination thereof, ordered or requested but not delivered; interrupted Local Services associated with any Element, or combination thereof, ordered or requested; Local Services, Elements, or Combination thereof, of poor quality; and installation problems if caused by BellSouth. Such reimbursements shall be set forth in the appropriate section of the CABS bill pursuant to CABS, standards.

*LB*

FL4/2/97

**17. Recording of Call Information**

**17.1** Where Telecommunications Services are being resold or unbundled Network Elements are being utilized, the Parties agree to record call information in accordance with this subsection. To the extent technically feasible, each Party will record and process the usage sensitive call detail information associated with the other Party's local exchange customer. The call records for the charged number shall be provided at a Party's request and shall be formatted pursuant to BellCore standards and the terms and conditions of this Agreement. BellSouth and AT&T agree that they will retain, at each Party's sole expense, copies of all AMA transmitted to the other Party for at least seven (7) calendar days after transmission to the other Party.

**17.2** Each Party will provide the other Party with a carrier identification code ("CIC") on each EMR record transmitted to the other Party. If BellSouth does not have a CIC for any local exchange carrier, BellSouth or IXC for whom BellSouth must supply to AT&T billing records or information pursuant to this Attachment, BellSouth agrees that it will assist the local exchange carrier, BellSouth or IC in obtaining a CIC expeditiously. Until the local exchange carrier, BellSouth or IXC has received a CIC, BellSouth agrees that it will submit its CIC to AT&T on those records for billing and payment. BellSouth further agrees that it will then be responsible for obtaining reimbursement for the respective charges from the appropriate carrier. Likewise, if AT&T does not have a CIC for any local exchange carrier, BellSouth or IXC for whom AT&T must supply to BellSouth billing records or information pursuant to this Attachment, AT&T agrees that it will assist the local exchange carrier, BellSouth or IXC in obtaining a CIC expeditiously. Until the local exchange carrier, BellSouth or IXC has received a CIC, AT&T agrees that it will submit its CIC to BellSouth on those records for billing and payment. AT&T further agrees that it will then be responsible for obtaining reimbursement for the respective charges from the appropriate carrier.

**17.3 DELETED**

**17.3.1 DELETED**

**17.3.2 DELETED**

**17.3.3 DELETED**

**17.4** The Parties agree that they will provide each other a single person to contact regarding any data exchange problems.

**18. DELETED**

*UB*  
FL4/2/97



Exhibit A

**REQUIREMENTS FOR NON-CABS BILLING  
OF  
AT&T LOCAL SERVICE RESALE**

AT&T and BellSouth agree to the following requirements for non-CABS billing for Local Service Resale:

- BellSouth will provide a 13 character alpha-numeric Billing Account Number (BAN)
- BellSouth will provide one (1) BAN per Regional Accounting Office (RAO)
- BellSouth will provide one (1) bill cycle for all BANs / RAOs excluding the 4th, 7th and 13th bill cycles
- BellSouth will render the bill within ten (10) days of the bill date
- AT&T will render payment 30 days from the bill date or 20 days from the date the bill is received, whichever is greater
- AT&T will render payment via wire transfer to the existing CABS billing address
- BellSouth will render billing for PIC charges separately
- BellSouth will bill monthly service charges in advance of the bill date
- BellSouth will bill usage charges in arrears of the bill date
- BellSouth will identify all charges by incurred state except in cross boundary situations
- All local billing is considered jurisdiction '5'
- BellSouth will uniquely identify the local billing BANs as Type Of Account 'Q'
- BellSouth will separately identify business and residence charges via 1FB or 1FR
- BellSouth will provide From and Through dates for all local billing

*UD*

FL4/2/97

Exhibit B

## BELLSOUTH LOCAL CARRIER SERVICE CENTER (LCSC) ESCALATION LIST

### LOCAL CARRIER SERVICE CENTER

<b>Telephone Numbers</b>	Office .....800-872-3116 Local Service Requests, LSR Questions, Billing Inquiries and General Assistance  Fax Number .....800-872-7059 All Forms
<b>Managers</b>	Director Barbara Warren .....700-451-0853  Manager Paula Murphy .....700-451-0883
<b>Mailing Address</b>	Local Carrier Service Center (LCSC) BellSouth Room D-20 5147 Peachtree Industrial Boulevard Chamblee, GA 30341
<b>Hours of Operation</b>	8:30 AM to 5:00 PM EST Monday - Friday
<b>Holidays Observed</b>	New Years Day Memorial Day Independence Day Labor Day Thanksgiving Day Christmas Day
<b>Process</b>	The long-term escalation process will be developed as part of the Quality Assurance program outlined in paragraph 12 of this attachment. In the interim, AT&T will escalate any billing discrepancies to the BellSouth LCSC Manager. If resolution is not attained within 30 days, AT&T will escalate the discrepancy to the BellSouth Director. If the billing discrepancy is not resolved within 30 days, AT&T will obtain the name and number

  
FL4/2/97

SERVICE DESCRIPTION: ANCILLARY FUNCTIONS

1 Introduction

This Attachment sets forth the descriptions and requirements for Ancillary Functions that BellSouth agrees to offer to AT&T under this Agreement. AT&T may use any Ancillary Function to provide any feature, function, or service option that such Ancillary Function is capable of providing or any feature, function, or service option that is described in the technical references identified herein.

2 Collocation

2.1 **Definition - Collocation means the right of AT&T to obtain space in BellSouth Premises and to place equipment in such spaces to interconnect with BellSouth network.**

2.2 Technical Requirements

2.2.1 **BellSouth shall provide space, as requested by AT&T, to meet AT&T's needs for placement of equipment, interconnection, or provision of service. AT&T and BellSouth will jointly establish a written business process within ninety (90) days after the execution this Agreement by which such space can be procured.**

2.2.2 **BellSouth shall provide intraoffice facilities (e.g., DS0, DS1, DS3, OC3, OC12, OC48, and STS-1 terminations) as requested by AT&T to meet AT&T's need for placement of equipment, interconnection, or provision of service.**

2.2.3 **BellSouth agrees to allow AT&T's employees and designated agents unrestricted access to AT&T dedicated space in manned BellSouth offices twenty-four (24) hours per day each day of the week. BellSouth may place reasonable security restrictions on access by AT&T's employees and designated agents to the AT&T collocated space in unmanned BellSouth offices. Notwithstanding, BellSouth agrees that such space shall be available to AT&T's employees and designated agents twenty-four (24) hours per day each day of the week. A security escort may be required in some locations for non-BellSouth personnel. AT&T agrees to ensure each employee, agent or contractor hired by and working on behalf of AT&T within BellSouth's central office openly wears a picture identification badge reflecting the individual's name, AT&T's name/logo or affiliation to AT&T.**

2.2.4 **AT&T may collocate the amount and type of equipment it deems necessary in its collocated space (e.g., AT&T utilizing its SONET termination equipment in the collocated space to provide a hub for**

- CC3/CC48 rings). BellSouth shall not restrict the types of equipment or vendors of equipment to be installed provided such equipment is used to provide Telecommunication Services. Such equipment must meet applicable industry standards.
- 2.2.5 BellSouth agrees to provide AT&T with interconnection of AT&T's collocated facilities to those of other carriers that are collocated in the same BellSouth Premise.
- 2.2.6 AT&T may select its own vendors for all required engineering and installation services associated with its collocated equipment (e.g., BellSouth shall not require AT&T to utilize BellSouth's internal engineering or installation work forces for the engineering and installation of AT&T's collocated equipment). Vendors utilized by AT&T must be on BellSouth's list of certified vendors.
- 2.2.7 BellSouth shall provide basic telephone service at the tariffed rate for basic service with a connection jack as requested by AT&T from BellSouth for the collocated space. Upon AT&T's request, this service shall be available at the AT&T collocated space on the day that the space is turned over to AT&T by BellSouth.
- 2.2.8 BellSouth shall provide adequate lighting, ventilation, power, heat, air conditioning, and other environmental conditions for AT&T's space and equipment. These environmental conditions shall adhere to Bell Communication Research (BellCore) Network Equipment-Building System (NEBS) standards TR-EOP-000063.
- 2.2.9 BellSouth shall provide access to eyewash stations, shower stations, bathrooms, and drinking water within the collocated facility on a twenty-four (24) hours per day, seven (7) days per week basis for AT&T personnel and its designated agents.
- 2.2.10 AT&T may request dual fiber entrance to the BellSouth Central Office. Where physically separate paths are not available, BellSouth will allow AT&T to provide physical separation of the fibers within the riser and/or support structure by the placement of conduit or similar covering around one of the entrance fibers. This covering will be no larger than necessary to accommodate the protection of this one fiber.
- 2.2.11 BellSouth shall ensure protection of AT&T's proprietary customer information. Any collocation arrangement shall include provisions for BellSouth protecting AT&T's proprietary information.
- 2.2.12 BellSouth shall participate in and adhere to negotiated service guarantees, DMOQs, and ISO reviews.

  
FL6/10/97

- 2.2.13 Within three (3) business days of AT&T's written request, BellSouth shall identify any known Environmental Hazard or Hazardous Materials in the space provided for placement of equipment and interconnection.
- 2.2.13.1 BellSouth shall allow AT&T to perform any environmental site investigations, including, but not limited to, asbestos surveys, which AT&T deems to be necessary in support of its collocation needs, at AT&T's expense.
- 2.2.13.2 If the space provided for the placement of equipment, interconnection, or provision of service contains an Environmental Hazard or Hazardous Material, particularly but not limited to asbestos, lead paint or radon, which makes the placement of such equipment or interconnection hazardous, BellSouth shall offer an alternative space, if available, for AT&T's consideration.
- 2.2.14 BellSouth shall provide AT&T with written notice five (5) business days prior to those instances where BellSouth or its subcontractors may be performing work in the general area of the collocated space occupied by AT&T, or in the general area of the AC and DC power plants which support AT&T equipment that may directly impact AT&T's equipment arrangement, facilities, or power supply. BellSouth will inform AT&T by telephone of any emergency related activity that BellSouth or its subcontractors may be performing in the general area of the collocated space occupied by AT&T, or in the general area of the AC and DC power plants which support AT&T equipment that may directly impact AT&T's equipment arrangement, facilities, or power supply. Notification of such emergency related activity shall be made immediately prior to the start of the activity so that AT&T can take any action required to monitor or protect its service.
- 2.2.15 BellSouth shall construct the collocated space in compliance with AT&T's collocation request for cable holes, ground bars, doors, and convenience outlets. Any deviation to AT&T's request will be jointly negotiated with BellSouth.
- 2.2.16 AT&T and BellSouth will complete an acceptance walk through of all collocated space requested from BellSouth. BellSouth will correct any deviations to AT&T's original or jointly amended request within five (5) business days after the walk through or a negotiated time frame, depending on the magnitude of the deviation, at BellSouth's expense. Any other additions or changes to the original or jointly amended request will be at AT&T's expense.

- 2.2.17 The Point of Termination pay will be part of cage walls of AT&T's designated space. The logistics and floor plan drawing will be discussed at the first joint planning meeting as referenced in 2.2.18 below
- 2.2.18 A joint planning meeting between BellSouth and AT&T will commence within a maximum of thirty (30) days from BellSouth's receipt of a complete and accurate firm order and the payment of agreed to fees. The parties will exchange the following information at such meeting and establish scheduling for multi-site installations:
- 2.2.18.1 Telephone Equipment drawings depicting the exact path with dimensions for AT&T Outside Plant Fiber ingress and egress into collocated space
- 2.2.18.2 Power feeder fuse slot assignment on the BellSouth Battery Distribution Frame Bay.
- 2.2.18.3 Work restriction guidelines.
- 2.2.18.4 Contact access and escalation process to the following areas:
- Engineering
  - Physical & Logical Security
  - Provisioning
  - Billing
  - Operations
  - Site and Building Managers
  - Environmental and Safety
- 2.2.19 BellSouth shall provide the AT&T selected certified equipment engineering vendor access to the Engineering Records Mark-up and Assignment (ERMA) Database for certified vendor power supply assignments.
- 2.2.20 BellSouth shall provide positive confirmation to AT&T when construction of AT&T collocated space is 50% completed. This confirmation shall also include confirmation of the scheduled completion and turnover dates. AT&T agrees to place operational telecommunications equipment in the BellSouth Premises and connect with BellSouth's network within one-hundred eighty (180) days of the space turnover date. If AT&T fails to do so, AT&T forfeits their rights to use the space on the thirtieth day after BellSouth provides AT&T written notice of such failure and AT&T does not place operational telecommunications in the premises and connect with BellSouth's network by such thirtieth day. In any such event, AT&T shall be liable in an amount equal to the unpaid balance of any preparation charges due.

- 2.2.21 BellSouth will reimburse AT&T in an amount equal to the AT&T expenditures incurred as a result as a direct result of delays in the negotiated completion and turnover dates caused by BellSouth
- 2.2.21.1 DELETED
- 2.2.21.2 DELETED
- 2.2.21.3 DELETED
- 2.2.21.4 DELETED
- 2.2.21.5 DELETED
- 2.2.22 Power as referenced in this document refers to any electrical power source supplied by BellSouth for AT&T equipment. It includes all superstructure, infrastructure, and overhead facilities, including, but not limited to, cable, cable racks and bus bars. BellSouth will supply power to support AT&T equipment at equipment specific DC and AC voltages. BellSouth shall supply power and power infrastructure to AT&T at parity with that provided by BellSouth to itself or to any third party. BellSouth's performance, availability, or restoration shall meet BellCore/NEBS standards. If BellSouth's performance, availability, or restoration fall below BellCore/NEBS standards, BellSouth will bring itself into compliance as soon as technologically feasible.
- 2.2.22.1 Central office power supplied by BellSouth into the AT&T equipment area, shall be supplied in the form of power feeders (cables) on cable racking into the designated AT&T equipment area. The power feeders (cables) shall efficiently and economically support the requested quantity and capacity of AT&T equipment. The termination location shall be as requested by AT&T. Any deviations will be jointly agreed upon by BellSouth and AT&T.
- 2.2.22.2 BellSouth shall provide power as requested by AT&T to meet AT&T's need for placement of equipment, interconnection, or provision of service.
- 2.2.22.3 BellSouth power equipment supporting AT&T's equipment shall:
- 2.2.22.3.1 Comply with applicable industry standards (e.g., BellCore, and NEBS or manufacturer's equipment power requirement specifications for equipment installation, and physical equipment layout. Manufacturer's cabling practices shall comply with industry standards that meet or exceed Bellcore or NEBS standards;



FL6/10/97

- 2.2.22.3.2 Have redundant power feeds with physical diversity and battery back-up at party with that provided for similar BellSouth equipment;
- 2.2.22.3.3 **DELETED**
- 2.2.22.3.4 Provide central office ground, connected to a ground electrode located within the AT&T collocated space, at a location which meets BellSouth standards and is jointly agreed upon by the parties at the initial planning meeting identified in Section 2.2.18 of this Attachment 3; and
- 2.2.22.3.5 Provide feeder capacity and quantity to support the ultimate equipment layout for AT&T equipment in accordance with AT&T's collocation request.
- 2.2.22.3.6 BellSouth shall, within ten (10) days of AT&T's request:
- 2.2.22.3.6.1 Provide an installation sequence and access that will allow installation efforts in parallel without jeopardizing personnel safety or existing AT&T services;
- 2.2.22.3.6.2 **DELETED**
- 2.2.22.3.6.3 Provide cabling that adheres to Bell Communication Research (BellCore) Network Equipment-Building System (NEBS) standards TR-EOP-000063; and
- 2.2.22.3.6.4 Provide Lock Out-Tag Out and other electrical safety procedures and devices in conformance with the most stringent of OSHA or industry guidelines.
- 2.2.22.3.6.5 BellSouth will provide AT&T with written notification within ten (10) business days of any scheduled AC or DC power work or related activity in the collocated facility that will or might cause an outage or any type of power disruption to AT&T equipment located in BellSouth facility. BellSouth shall provide AT&T immediate notification by telephone of any emergency power activity that would impact AT&T equipment.
- 2.3 BellSouth will permit AT&T to inspect supporting documents for contracted work done on behalf of AT&T (i.e., AIA document G702).
- 2.4 **Physical Security Requirements**
- 2.4.1 BellSouth agrees to use card access readers (door locks) or equivalent that will provide an audit trail of persons entering doors of facilities that have AT&T equipment or equipment enclosures.



2.4.2 BellSouth will ensure that the building area which houses AT&T equipment is adequately secured and monitored to prevent entry

BellSouth will provide timely notification to the AT&T personnel designated on AT&T's enclosures of an actual or attempted security breach to space housing AT&T equipment or AT&T enclosures when BellSouth has actual knowledge of an actual or threatened security breach.

2.5 Technical References - BellSouth agrees to comply with all BellCore and ANSI standards that are directly applicable to construct, supply and maintain collocation. Such standards include:

- National Electrical Code (NEC)
- NEBS Generic Engineering Requirements for System Assembly and Cable Distribution
- Generic Requirements for -24, -48, -130, and -140 Volt Central Office Power Plant Rectifiers. (BellCore)

2.5.1 DELETED

2.5.2 DELETED

2.5.3 DELETED

2.5.4 DELETED

2.5.5 DELETED

2.5.6 DELETED

2.5.7 DELETED

2.5.8 DELETED

2.5.9 DELETED

2.5.10 DELETED

2.5.11 DELETED

3. **Rights of Way (ROW), Conduits and Pole Attachments**

This Section 3, Poles, Conduits and Rights-of-Way to Attachment Ancillary Functions to the Agreement sets forth the terms and conditions under which BellSouth shall afford to AT&T access to BellSouth's poles, ducts, conduits and Rights-of-way, pursuant to the Act.



3.1 DEFINITIONS

3.1.1 Definitions in General. Except as the context otherwise requires, the terms defined in this Section shall, as used in this Section, have the meanings set forth in 3.1.2 through 3.1.31.

3.1.2 DELETED

3.1.3 Anchor. The term "anchor" refers to a device, structure, or assembly which stabilizes a pole and holds it in place. An anchor assembly may consist of a rod and fixed object or plate, typically embedded in the ground, which is attached to a guy strand or guy wire, which, in turn, is attached to the pole. The term "anchor" does not include the guy strand which connects the anchor to the pole and includes only those anchors which are owned by BellSouth, as distinguished from anchors which are owned and controlled by other persons or entities.

3.1.4 Anchor/guy strand. The term "anchor/guy strand" refers to supporting wires, typically stranded together, or other devices attached to a pole and connecting that pole to an anchor or to another pole for the purpose of increasing pole stability. The term "anchor/guy strand" includes, but is not limited to, strands sometimes referred to as "anchor strands," "down guys," "guy strands," and "pole-to-pole guys."

3.1.5 Communications Act of 1934. The terms "Communications Act of 1934" and "Communications Act" refer to the Communications Act of June 19, 1934, 48 Stat. 1064, as amended, including the provisions codified as 47 U.S.C. Sections 151 et seq. The Communications Act includes the Pole Attachment Act of 1978, as defined in this Article 3.1.

3.1.6 Assigned. The term "assigned", when used with respect to conduit or duct space or pole attachment space, refers to any space in such conduit or duct or on such pole that is occupied by a telecommunications service provider or a municipal or other governmental authority. To ensure the judicious use of poles and conduits, space "assigned" to a telecommunications service provider must be physically occupied by the service provider, be it BellSouth or a new entrant, within twelve (12) months of the space being "assigned".

3.1.7 Available. The term "available", when used with respect to conduit or duct space or pole attachment space, refers to any usable space in such conduit or duct or on such pole not assigned to a specific provider at the applicable time.

- 3.1.8 Conduit occupancy. The terms "conduit occupancy" and "occupancy" refer to the presence of wire, cable, optical conductors, or other facilities within any portion of BellSouth's conduit system.
- 3.1.9 Conduit system. The term "conduit system" refers to any combination of ducts, conduits, manholes, and handholes joined to form an integrated whole. In this Section, the term refers to conduit systems owned or controlled by BellSouth.
- 3.1.10 Cost. The term "cost" as used herein refers to charges made by BellSouth to AT&T for specific work performed, and shall be (a) the actual charges made by subcontractors to BellSouth for work and/or (b) if the work was performed by BellSouth employees, the rates set forth in Part 4 of this Agreement shall apply for such work.
- 3.1.11 Duct. The term "duct" refers to a single enclosed tube, pipe, or channel for enclosing and carrying cables, wires, and other facilities. As used in this Section, the term "duct" includes "inner ducts" created by subdividing a duct into smaller channels.
- 3.1.12 Facilities. The terms "facility" and "facilities" refer to any property or equipment utilized in the provision of telecommunication services.
- 3.1.13 The acronym "FCC" refers to the Federal Communications Commission.
- 3.1.14 Inner-Duct. The term "inner-duct" refers to a pathway created by subdividing a duct into smaller channels.
- 3.1.15 **DELETED**
- 3.1.16 Licensee. The term "licensee" refers to a person or entity which has entered or may enter into an agreement or arrangement with BellSouth permitting such person or entity to place its facilities in BellSouth's conduit system or attach its facilities to BellSouth's poles or anchors.
- 3.1.17 Lashing. The term "lashing" refers to the attachment of a licensee's sheath or inner-duct to a supporting strand.
- 3.1.18 License. The term "license" refers to any license issued pursuant to this Agreement and may, if the context requires, refer to conduit occupancy or pole attachment licenses issued by BellSouth prior to the date of this Agreement.



- 3.1.19 **Make-Ready work.** The term "make-ready work" refers to all work performed or to be performed, including administrative processing as described in 3.8.4) to prepare BellSouth's conduit systems, poles or anchors and related facilities for the requested occupancy or attachment of AT&T's facilities. "Make-Ready work" includes, but is not limited to, cleaning obstructions (e.g., by "rodding" ducts to ensure clear passage), the rearrangement, transfer, replacement, and removal of existing facilities on a pole or in a conduit system where such work is required solely to accommodate AT&T's facilities and not to meet BellSouth's business needs or convenience. "Make-Ready work" may require "dig-ups" of existing facilities and may include the repair, enlargement or modification of BellSouth's facilities (including, but not limited to, conduits, ducts, handholes and manholes) or the performance of other work required to make a pole, anchor, conduit or duct usable for the initial placement of AT&T's facilities.
- 3.1.20 **Manhole.** The term "manhole" refers to an enclosure, usually below ground level and entered through a hole on the surface covered with a cast iron or concrete manhole cover, which personnel may enter and use for the purpose of installing, operating, and maintaining facilities in a conduit.
- 3.1.21 **Occupancy.** The term "occupancy" shall refer to the physical presence of telecommunication facilities in a duct, on a pole, or within a Right-of-way.
- 3.1.22 **Person acting on AT&T's behalf.** The terms "person acting on AT&T's behalf," "personnel performing work on AT&T's behalf," and similar terms include both natural persons and firms and ventures of every type, including, but not limited to, corporations, partnerships, limited liability companies, sole proprietorships, and joint ventures. The terms "person acting on AT&T's behalf," "personnel performing work on AT&T's behalf," and similar terms specifically include, but are not limited to, AT&T, its officers, directors, employees, agents, representatives, attorneys, contractors, subcontractors, and other persons or entities performing services at the request of or as directed by AT&T and their respective officers, directors, employees, agents, and representatives.
- 3.1.23 **Person acting on BellSouth's behalf.** The terms "person acting on BellSouth's behalf," "personnel performing work on BellSouth's behalf," and similar terms include both natural persons and firms and ventures of every type, including but not limited to corporations, partnerships, limited liability companies, sole proprietorships, and joint ventures. The terms "person acting on BellSouth's behalf," "personnel performing work on BellSouth's behalf," and similar terms specifically include, but are not

limited to BellSouth, its officers, directors, employees, agents, representatives, attorneys, contractors, subcontractors, and other persons or entities performing services at the request or on behalf of BellSouth and their respective officers, directors, employees, agents, and representatives.

- 3.1.24 **Pole.** The term "pole" refers to both utility poles and anchors but only to those utility poles and anchors owned or controlled by BellSouth, and does not include utility poles or anchors with respect to which BellSouth has no legal authority to permit attachments by other persons or entities.
- 3.1.25 **Pole Attachment Act.** The terms "Pole Attachment Act" and "Pole Attachment Act of 1978" refer to those provisions of the Communications Act of 1934, as amended, now codified as 47 U.S.C. § 224.
- 3.1.26 **Prelicense survey.** The term "prelicense survey" refers to all work and activities performed or to be performed to determine whether there is adequate capacity on a pole or in a conduit or conduit system (including manholes and handholes) to accommodate AT&T's facilities and to determine what make-ready work, if any, is required to prepare the pole, conduit or conduit system to accommodate AT&T's facilities.
- 3.1.27 **Right of Way (ROW).** The term "right of way" refers to the right to use the land or other property of another party to place poles, conduits, cables, other structures and equipment, or to provide passage to access such structures and equipment. A Right of Way may run under, on, or above public or private property (including air space above public or private property) and may include the right to use discrete space in buildings, building complexes, or other locations.
- 3.1.28 **Sheath.** The term "sheath" refers to a single outer covering containing communications wires, fibers, or other communications media.
- 3.1.29 **Spare Capacity.** The term "spare capacity" refers to any pole attachment space, conduit, duct or inner-duct not currently assigned or subject to a pending application for attachment/occupancy. Spare capacity does not include an inner-duct (not to exceed one inner-duct per party) reserved by BellSouth, AT&T, or a third party for maintenance, repair, or emergency restoration.
- 3.1.30 **State.** When capitalized, the term "State" (as used in terms such as "this State") refers to the State of Florida.
- 3.1.31 **Third Party.** The terms "third party" and "third parties" refer to persons and entities other than AT&T and BellSouth. Use of the term "third party"

does not signify that any such person or entity is a party to this Agreement or has any contractual rights hereunder

- 3.1.32 DELETED
- 3.1.33 DELETED
- 3.1.33.1 DELETED
- 3.1.33.2 DELETED
- 3.1.33.3 DELETED
- 3.1.33.4 DELETED
- 3.2 [RESERVED FOR FUTURE USE]
- 3.3 DELETED
- 3.3.1 DELETED
- 3.3.2 DELETED
- 3.3.2.1 DELETED
- 3.3.2.2 DELETED
- 3.3.2.3 DELETED
- 3.3.2.4 DELETED
- 3.3.2.5 DELETED
- 3.3.2.6 DELETED
- 3.3.3 DELETED
- 3.3.3.1 DELETED
- 3.3.3.2 DELETED
- 3.3.3.3 DELETED
- 3.3.4 DELETED

3.4 SCOPE OF AGREEMENT

3.4.1 Scope of Agreement. BellSouth shall provide AT&T with equal and nondiscriminatory access to pole space, conduits, ducts, and rights-of-way on terms and conditions equal to those provided by BellSouth to itself or to any other telecommunications service provider. Further, BellSouth shall not withhold or delay assignment of such facilities to AT&T because of the potential or forecasted needs of itself or other parties.

3.4.2 Attachments and Occupancies Authorized by this Section. BellSouth shall issue one or more licenses to AT&T authorizing AT&T to attach facilities to BellSouth's owned or controlled poles and to place facilities within BellSouth's owned or controlled conduits, ducts or rights-of-way under the terms and conditions set forth in this Section and the Telecommunications Act of 1996.

3.4.2.1 Unless otherwise provided herein, authority to attach facilities to BellSouth's owned or controlled poles, to place facilities within BellSouth's owned or controlled conduits, ducts or rights-of-way shall be granted only in individual licenses granted under this Section and the placement or use of such facilities shall be determined in accordance with such licenses and procedures established in this Section.

3.4.2.2 AT&T agrees that its attachment of facilities to BellSouth's owned or controlled poles, occupancy of BellSouth's owned or controlled conduits, ducts or rights-of-way shall take place pursuant to the licensing procedures set forth herein, and BellSouth agrees that it shall not unreasonably withhold or delay issuance of such licenses.

3.4.2.3 **DELETED**

3.4.3 Subject to the terms and conditions set forth in this Section, BellSouth shall issue to AT&T one or more licenses authorizing AT&T to place or attach facilities in or to specified poles, conduits, ducts or rights-of-way owned or controlled by BellSouth located within this State on a first come, first served basis. If BellSouth determines that the pole, conduit or duct space specifically requested by AT&T is necessary to meet BellSouth's present needs, or is licensed by BellSouth to another licensee, or is otherwise unavailable based on engineering concerns, BellSouth shall have the right to designate the particular duct(s) to be occupied, the location and manner in which AT&T's facilities will enter and exit BellSouth's conduit system and the specific location and manner of installation for any associated equipment which is permitted by BellSouth to occupy the conduit system, provided that BellSouth shall provide written notice to AT&T within a reasonable time specifying in detail the reasons for denying AT&T's request. If AT&T disagrees with BellSouth's

  
FL6/10/97

determination, the matter may be submitted to the Alternative Dispute Resolution Process, described in Attachment 1.

- 3.4.4 Access and Use of Rights-of-Way BellSouth acknowledges that it is required by the Telecommunications Act of 1996 to afford AT&T access to and use of all associated rights-of-way to any sites where BellSouth's owned or controlled poles, manholes, conduits, ducts or other parts of BellSouth's owned or controlled conduit systems are located.
- 3.4.4.1 BellSouth shall provide AT&T with access to and use of such rights-of-way to the same extent and for the same purposes that BellSouth may access or use such rights-of-way, including but not limited to access for ingress, egress or other access and to construct, utilize, maintain, modify and remove facilities for which pole attachment, conduit occupancy, or ROW use licenses have been issued, provided that any agreement with a third party under which BellSouth holds such rights expressly or impliedly grants BellSouth the right to provide such rights to others.
- 3.4.4.2 Where BellSouth notifies AT&T that a BellSouth's agreement with a third party does not expressly or impliedly grant BellSouth the ability to provide such access and use rights to others, upon AT&T's request, BellSouth will use its best efforts to obtain the owner's consent and to otherwise secure such rights for AT&T. AT&T agrees to reimburse BellSouth for the reasonable and demonstrable costs incurred by BellSouth in obtaining such rights for AT&T.
- 3.4.4.3 In cases where a third party agreement does not grant BellSouth the right to provide access and use rights to others as contemplated in 3.4.4.1 and BellSouth, despite its best efforts, is unable to secure such access and use rights for AT&T in accordance with 3.4.4.2, or, in the case where AT&T elects not to invoke its rights under 3.4.4.1 or 3.4.4.2, AT&T shall be responsible for obtaining such permission to access and use such rights-of-way. BellSouth shall cooperate with AT&T in obtaining such permission and shall not prevent or delay any third party assignment of ROWs to AT&T.
- 3.4.4.4 Where BellSouth has any ownership or rights-of-way to buildings or building complexes, or within buildings or building complexes, BellSouth shall offer to AT&T through a license or other agreement:
- 3.4.4.4.1 The right to use any available space owned or controlled by BellSouth in the building or building complex to install AT&T equipment and facilities; and
- 3.4.4.4.2 Ingress and egress to such space.



- 3.4.4.3 **DELETED**
- 3.4.5 Except to the extent necessary to meet the requirements of the Telecommunications Act of 1996, neither this Section nor any license granted hereunder shall constitute a conveyance or assignment of any of either party's rights to use any public or private rights-of-way, and nothing contained in this Section or in any license granted hereunder shall be construed as conferring on one party any right to interfere with the other party's access to any such public or private rights-of-way.
- 3.4.6 No Effect on BellSouth's Right to Convey Property. Nothing contained in this Section or in any license issued hereunder shall in any way affect the right of BellSouth to convey to any other person or entity any interest in real or personal property, including any poles, conduit or ducts to or in which AT&T has attached or placed facilities pursuant to licenses issued under this Section provided however that BellSouth shall give AT&T reasonable advance written notice of such intent to convey.
- 3.4.7 No Effect on BellSouth's Rights to Manage its Own Facilities. This Section shall not be construed as limiting or interfering with BellSouth's rights set forth below, except to the extent expressly provided by the provisions of this Section or licenses issued hereunder or by the Telecommunications Act of 1996 or other applicable laws, rules or regulations:
- 3.4.7.1 To locate, relocate, move, replace, modify, maintain, and operate BellSouth's own facilities within BellSouth's conduits, ducts or rights-of-way or any of BellSouth's facilities attached to BellSouth's poles at any time and in any reasonable manner which BellSouth deems appropriate to serve its customers, avail itself of new business opportunities, or otherwise meet its business needs; or
- 3.4.7.2 To enter into new agreements or arrangements with other persons or entities permitting them to attach or place their facilities to or in BellSouth's poles, conduits or ducts; provided, however, that such relocations, moves, replacements, modifications, maintenance and operations or new agreements or arrangements shall not substantially interfere with AT&T's pole attachment, conduit occupancy or ROW use, rights provided by licenses issued pursuant to this Section.
- 3.4.8 No Effect on AT&T's Rights to Manage its Own Facilities. This Section shall not be construed as limiting or interfering with AT&T's rights set forth below, except to the extent expressly provided by the provisions of this Section or licenses issued hereunder or by the Telecommunications Act of 1996 or other applicable laws, rules or regulations:

- 3.4.8.1 To locate, relocate, move, replace, modify, maintain, and operate its own facilities within BellSouth's conduits, ducts or rights-of-way or its facilities attached to BellSouth's poles at any time and in any reasonable manner which AT&T deems appropriate to serve its customers, avail itself of new business opportunities, or otherwise meet its business needs; or
- 3.4.8.2 To enter into new agreements or arrangements with other persons or entities permitting AT&T to attach or place its facilities to or in such other persons' or entities' poles, conduits or ducts, or rights-of-way; provided, however, that such relocations, moves, replacements, modifications, maintenance and operations or new agreements or arrangements shall not conflict with AT&T's obligations under licenses issued pursuant to this Section.
- 3.4.9 No Right to Interfere with Facilities of Others. The provisions of this Section or any license issued hereunder shall not be construed as authorizing either party to this Section to rearrange or interfere in any way with any of the other party's facilities, with the facilities of other persons or entities, or with the use of or access to such facilities by such other party or such other persons or entities, except to the extent expressly provided by the provisions of this Section or any license issued hereunder or by the Telecommunications Act of 1996 or other applicable laws, rules or regulations.
- 3.4.9.1 **DELETED**
- 3.4.9.2 AT&T acknowledges that the facilities of persons or entities other than BellSouth and AT&T may be attached to or occupy BellSouth's poles, conduits, ducts and rights-of-way.
- 3.4.9.3 BellSouth shall not attach, or give permission to any third parties to attach facilities to, existing AT&T facilities without AT&T's prior written consent. If BellSouth becomes aware of any such unauthorized attachment to AT&T facilities, BellSouth shall use its best efforts to rectify the situation as soon as practicable.
- 3.4.10 **DELETED**
- 3.4.10.1 With respect to facilities occupied by AT&T or the subject of an application for attachment by AT&T, BellSouth will give to AT&T 60 days' written notice for conduit extensions or reinforcements, 60 days' written notice for pole line extensions, 60 days' written notice for pole replacements, and 60 days' written notice of BellSouth's intention to construct, reconstruct, expand or place such facilities or of BellSouth's intention not to maintain or use any existing facility and, in the case of an existing facility which BellSouth elects not to maintain or use, BellSouth will grant to AT&T a

right to maintain and use such facility. If an emergency or provision or an applicable joint use agreement requires BellSouth to construct, reconstruct, expand or replace poles, conduits or ducts occupied by AT&T or the subject of an application for attachment by AT&T, BellSouth will notify AT&T as soon as reasonably practicable of such proposed construction, reconstruction, expansion or replacement to enable AT&T, if it so desires, to request that a pole, conduit or duct of greater height or capacity be utilized to accommodate an anticipated facility need of AT&T.

- 3.4.10.2 At AT&T's expense, BellSouth shall remove any retired cable from conduit systems to allow for the efficient use of conduit space within a reasonable period of time. If the parties are unable to agree to such removal arrangements, the matter may be submitted to the Alternative Dispute Resolution Process, described in Attachment 1, by either party.
- 3.4.10.3 BellSouth will allow AT&T and other parties to reserve capacity under the same time frames, terms and conditions that it affords itself. This includes reservations of emergency ducts as well as ducts for growth and other purposes. AT&T, if it so chooses, may reserve one emergency duct for itself and then offer to share this duct with other telecommunication carriers that are willing to enter into such a sharing agreement.
- 3.4.11 Assignment of Space. Assignment of space on poles, in conduits or ducts and within ROWs will be made pursuant to licenses granted by BellSouth on an equal basis to BellSouth, AT&T and other telecommunication service providers.

### 3.5 REQUIREMENTS AND SPECIFICATIONS

- 3.5.1 Published Standards Incorporated in this Section by Reference. AT&T agrees that its facilities shall be placed, constructed, maintained, repaired, and removed in accordance with current (as of the date when such work is performed) editions of the following publications, each of which is incorporated by reference as part of this Section :
- 3.5.1.1. The Blue Book Manual of Construction Procedures, Special Report SR-TAP-001421, published by Bell Communications Research, Inc. ("Bellcore"), and sometimes referred to as the "Blue Book";
- 3.5.1.2 The National Electrical Code (NEC); and
- 3.5.1.3 The National Electrical Safety Code (NESC).
- 3.5.2 Changes in Published Standards. AT&T agrees to rearrange its facilities in accordance with changes in the standards published in the publications

specified in Article 3.5.1 of this Attachment if required by law to do so or upon the mutual agreement of the parties.

- 3.5.3 Additional Electrical Design Specifications. AT&T agrees that, in addition to specifications and requirements referred to in Articles 3.5.1-3.5.2 above, AT&T's facilities placed in BellSouth's conduit system shall meet all of the following electrical design specifications:
- 3.5.3.1 No facility shall be placed in BellSouth's conduit system in violation of FCC regulations.
- 3.5.3.2 AT&T's facilities placed in BellSouth's conduit system shall not be designed to use the earth as the sole conductor for any part of AT&T's circuits.
- 3.5.3.3 AT&T's facilities carrying more than 50 volts AC (rms) to ground or 135 volts DC to ground shall be enclosed in an effectively grounded sheath or shield.
- 3.5.3.4 No coaxial cable of AT&T shall occupy a conduit system containing BellSouth's cable unless such cable of AT&T meets the voltage limitations of Article 820 of the National Electrical Code.
- 3.5.3.5 AT&T's coaxial cable may carry continuous DC voltages up to 1800 volts to ground where the conductor current will not exceed one-half amperes and where such cable has two separate grounded metal sheaths or shields and a suitable insulating jacket over the outer sheath or shield. The power supply shall be so designed and maintained that the total current carried over the outer sheath shall not exceed 200 micro amperes under normal conditions. Conditions which would increase the current over this level shall be cleared promptly.
- 3.5.3.6 Neither party shall circumvent the other party's corrosion mitigation measures. Each party's new facilities shall be compatible with the other party's facilities so as not to damage any facilities of the other party by corrosion or other chemical reaction.
- 3.5.4 Additional Physical Design Specifications. AT&T's facilities placed in BellSouth's conduit system must meet all of the following physical design specifications:
- 3.5.4.1 Cables bound or wrapped with cloth or having any kind of fibrous coverings or impregnated with an adhesive material shall not be placed in BellSouth's conduit or ducts.

- 3.5.4.2 The integrity of BellSouth's conduit system and overall safety of BellSouth's personnel and other personnel working in BellSouth's conduit system requires that "dielectric cable" be required when AT&T's cable facility utilizes an alternative duct or route that is shared in the same trench by any current carrying facility of a power utility.
- 3.5.4.3 New construction splices in AT&T's fiber optic and twisted pair cables shall be located in manholes, pull boxes or handholes.
- 3.5.5 Additional Specifications Applicable to Connections. The following specifications apply to connections of AT&T's conduit to BellSouth's conduit system:
- 3.5.5.1 AT&T will be permitted to connect its conduit or duct only at the point of a BellSouth manhole. No attachment will be made by entering or breaking into conduit between manholes. All necessary work to install AT&T facilities will be performed by AT&T or its contractor at AT&T's expense. In no event shall AT&T or its contractor "core bore" or make any other modification to BellSouth manhole(s) without the prior written approval of BellSouth, which approval will not be unreasonably delayed or withheld.
- 3.5.5.2 BellSouth may monitor, at AT&T's expense, the entrance and exit of AT&T's facilities into BellSouth's manholes and the placement of AT&T's facilities in BellSouth's manholes.
- 3.5.5.3 If AT&T constructs or utilizes a duct connected to BellSouth's manhole, the duct and all connections between that duct and BellSouth's manhole shall be sealed, to the extent practicable, to prevent the entry of gases or liquids into BellSouth's conduit system. If AT&T's duct enters a building, it shall also be sealed where it enters the building and at all other locations necessary to prevent the entry of gases and liquids from the building into BellSouth's conduit system.
- 3.5.6 Requirements Relating to Personnel, Equipment, Material, and Construction Procedures Generally. Duct clearing, rodding or modifications required to grant AT&T access to BellSouth's conduit systems may be performed by BellSouth at AT&T's expense at charges which represent BellSouth's actual costs. Alternatively (at AT&T's option) such work may be performed by a contractor who demonstrates compliance with BellSouth certification requirements, which certification requirements shall be consistent with F.C.C. rules. The parties acknowledge that AT&T, its contractors, and other persons acting on AT&T's behalf will perform work for AT&T (e.g., splicing AT&T's facilities) within BellSouth's conduit system. AT&T represents and warrants that neither AT&T nor any person acting on AT&T's behalf shall permit any person to climb or work on or in any of BellSouth's poles or to enter

*UB*

BellSouth's manholes or work within BellSouth's conduit system unless such person has the training, skill, and experience required to recognize potentially dangerous conditions relating to pole or the conduit systems and to perform the work safely.

- 3.5.6.1 AT&T's facilities within BellSouth's conduit system shall be constructed, placed, rearranged, modified, and removed upon receipt of license specified in 3.7.1. However, no such license will be required for the inspection, maintenance, repair or non-physical modifications of AT&T's facilities.
- 3.5.6.2 "Rodding" or clearing of ducts in BellSouth's conduit system shall be done only when specific authorization for such work has been obtained in advance from BellSouth, which authorization shall not be unreasonably delayed or withheld by BellSouth. The parties agree that such rodding or clearing shall be performed according to existing industry standards and practices. AT&T may contract with BellSouth for performance of such work or (at AT&T's option) with a contractor who demonstrates compliance with BellSouth certification requirements.
- 3.5.6.3 Personnel performing work on BellSouth's or AT&T's behalf in BellSouth's conduit system shall not climb on, step on, or otherwise disturb the other party's or any third party's cables, air pipes, equipment, or other facilities located in any manhole or other part of BellSouth's conduit system.
- 3.5.6.4 Personnel performing work on BellSouth's or AT&T's behalf within BellSouth's conduit system (including any manhole) shall, upon completing their work, make reasonable efforts to remove all tools, unused materials, wire clippings, cable sheathing and other materials brought by them to the work site.
- 3.5.6.5 All of AT&T's facilities shall be firmly secured and supported in accordance with Bellcore and industry standards.
- 3.5.6.6 AT&T's facilities shall be plainly identified with AT&T's name in each manhole with a firmly affixed permanent tag that meets standards set by BellSouth for its own facilities.
- 3.5.6.7 Manhole pumping and purging required in order to allow AT&T's work operations to proceed shall be performed by AT&T or its contractor in compliance with BellSouth Practice Sec. 620-145-011BT, "Manhole Contaminants, Water, Sediment or Debris Removal and Reporting Procedures," and any amendments, revisions or supplements thereto and in compliance with all regulations and standards established by the United States Environmental Protection Agency and by any applicable state or local environmental regulators.

- 3.5.6.8 Planks or other types of platforms shall not be installed using cables, pipes or other equipment as a means of support. Platforms shall be supported only by cable racks.
- 3.5.6.9 Any leak detection liquid or device used by AT&T or personnel performing work on AT&T's facilities within BellSouth's conduit system shall be of a type approved by BellSouth or Bellcore.
- 3.5.6.10 When AT&T or personnel performing work on AT&T's behalf are working within or in the vicinity of any part of BellSouth's poles or conduit system which is located within, under, over, or adjacent to streets, highways, alleys or other traveled rights-of-way, AT&T and all personnel performing work on AT&T's behalf shall follow procedures which AT&T deems appropriate for the protection of persons and property. AT&T shall be responsible, at all times, for determining and implementing the specific steps required to protect persons and property at the site. AT&T will provide all traffic control and warning devices required to protect pedestrian and vehicular traffic, workers and property from danger. AT&T has sole responsibility for the safety of all personnel performing work on AT&T's behalf, for the safety of bystanders, and for insuring that all operations conform to current OSHA regulations and all other governmental rules, ordinances or statutes. BellSouth reserves the right to suspend AT&T's activities on, in or in the vicinity of BellSouth's poles or conduit system if, in BellSouth's reasonable judgment, any hazardous condition arises due to the activity (including both acts and omissions) of AT&T or any personnel performing work on AT&T's behalf, which suspension shall cease when the condition has been rectified.
- 3.5.6.11 Except for protective screens, no temporary cover shall be placed by AT&T or personnel performing work on AT&T's behalf over an open manhole unless it is at least four feet above the surface level of the manhole opening.
- 3.5.6.12 Smoking or the use of any open flame is prohibited in BellSouth's manholes, in any other portion of BellSouth's conduit system, or within 10 feet of any open manhole entrance; provided that this provision will not prohibit the use of spark producing tools such as electric drills, fusion splicers, etc.
- 3.5.6.13 Artificial lighting, when required, will be provided by AT&T. Only explosion-proof lighting fixtures shall be used.
- 3.5.6.14 Neither AT&T nor personnel performing work on AT&T's behalf shall allow any combustible gas, vapor, liquid, or material to accumulate in BellSouth's conduit system (including any manhole) during work



FL6/10/97

operations performed within or in the vicinity of BellSouth's conduit system.

- 3.5.6.15. AT&T will abide by any laws, regulations or ordinances regarding the use of spark producing tools, equipment or devices in BellSouth's manholes, in any other portions of BellSouth's conduit system, or within 10 feet of any open manhole opening. This includes, but is not limited to, such tools as electric drills and hammers, meggers, breakdown sets, induction sets, and the like.
- 3.5.6.16. **DELETED**
- 3.5.7. Opening of Manholes. The following requirements apply to the opening of BellSouth's manholes and the authority of BellSouth personnel present when work on AT&T's behalf is being performed within or in the vicinity of BellSouth's conduit system.
- 3.5.7.1. BellSouth's manholes shall be opened only as permitted by BellSouth's authorized employees or agents, which permission shall not be unreasonably denied or delayed.
- 3.5.7.2. AT&T shall notify BellSouth forty-eight (48) hours in advance of any routine work operation requiring entry into any of BellSouth's manholes.
- 3.5.7.3. AT&T shall be responsible for obtaining any necessary authorization from appropriate authorities to open manholes for conduit work operations therein.
- 3.5.7.4. BellSouth's authorized employee or agent shall not direct or control the conduct of AT&T's work at the work site. The presence of BellSouth's authorized employee or agent at the work site shall not relieve AT&T or personnel performing work on AT&T's behalf of their responsibility to conduct all work operations within BellSouth's conduit system in a safe and workmanlike manner.
- 3.5.7.5. Although BellSouth's authorized employee or agent shall not direct or control the conduct of AT&T's work at the work site, BellSouth's employee or agent shall have the authority to suspend AT&T's work operations within BellSouth's conduit system if, in the reasonable discretion of such BellSouth employee or agent, it appears that any hazardous conditions arise or any unsafe practices are being followed by AT&T or personnel performing work on AT&T's behalf.
- 3.5.8. OSHA Compliance: Notice to BellSouth of Unsafe Conditions. AT&T agrees that:

  
FL6/10/97



- 3.5.8.1 Its facilities shall be constructed, placed, maintained, repaired, and removed in accordance with the Occupational Safety and Health Act (OSHA) and all rules and regulations promulgated thereunder;
- 3.5.8.2 All persons acting on AT&T's behalf, including but not limited to AT&T's employees, agents, contractors, and subcontractors shall, when working on or within BellSouth's poles or conduit system, comply with OSHA and all rules and regulations thereunder;
- 3.5.8.3 AT&T shall establish appropriate procedures and controls to assure compliance with all requirements of this section; and
- 3.5.8.4 AT&T (and any person acting on AT&T's behalf) may report unsafe conditions on, in or in the vicinity of BellSouth's poles or conduit system to BellSouth.

3.5.9 Compliance with Environmental Laws and Regulations.

AT&T acknowledges that, from time to time, environmental contaminants may enter BellSouth's conduit system and accumulate in manholes or other conduit facilities and that certain conduits (transite) are constructed with asbestos-containing materials. Before AT&T is required to make a commitment with respect to available space, AT&T shall have the right but not the duty to sample for asbestos conduits and other facilities it may need to puncture, abrade or otherwise disturb to determine whether or not to accept such space. If BellSouth has knowledge of the presence of such contaminants in a conduit for which AT&T has applied for or holds a license, BellSouth will promptly notify AT&T of such fact (i) in a manner that is at least equal to the notice BellSouth provides to its employees and (ii) in accordance with applicable laws and regulations.

BellSouth makes no representations to AT&T or personnel performing work on AT&T's behalf that BellSouth's conduit system or any specific portions thereof will be free from environmental contaminants at any particular time. The acknowledgments and representations set forth herein are not intended to relieve BellSouth of any liability which it would otherwise have under applicable law for the presence of environmental contaminants in its conduit facilities. AT&T agrees to comply with the following provisions relating to compliance with environmental laws and regulations:

- 3.5.9.1 AT&T's facilities shall be constructed, placed, maintained, repaired, and removed in accordance with all applicable federal, state, and local environmental statutes, ordinances, rules, regulations, and other laws, including but not limited to the Resource Conservation and Recovery Act

Compliance with Other Governmental Requirements. AT&T agrees that its facilities attached to BellSouth's facilities shall be constructed, placed, maintained, and removed in accordance with the ordinances, rules, and regulations of any governing body having jurisdiction of the subject matter. AT&T shall comply with all statutes, ordinances, rules, regulations and other laws requiring the marking and lighting of aerial wires, cables and other structures to ensure that such wires, cables and structures are not a hazard to aeronautical navigation. AT&T shall establish appropriate procedures and controls to assure such compliance by all persons acting

3.5.10

AT&T and all personnel performing work on AT&T's behalf shall comply with such standards and practices as BellSouth and AT&T may from time to time mutually agree to adopt to comply with environmental laws and regulations including, without limitation, BellSouth Practice Sec. 620-145-011 BT, "Manhole Contaminants, Water, Sediment or Debris Removal and Reporting Procedures". Pursuant to this practice, neither AT&T nor BellSouth nor personnel performing work on either party's behalf shall discharge water or any other substance from any BellSouth manhole or other conduit facility onto public or private property, including any storm water drainage system, without first testing such water or substance for contaminants in accordance with mutually agreed standards and practices and determining that such discharge would not violate any environmental law, create any environmental risk or hazard, or damage the property of any person. Proper handling and disposal of any waste material from a BellSouth manhole by AT&T or its contractor shall be the responsibility of AT&T. No such waste material shall be deposited on BellSouth premises for storage or disposal.

3.5.9.4

AT&T shall establish appropriate procedures and controls to assure compliance with all requirements of this section. BellSouth will be afforded a reasonable opportunity to review such procedures and controls and provide comments that will be reasonably considered in advance of their implementation. Review and comment by BellSouth pursuant to this section will be provided in a timely manner.

3.5.9.3

All persons acting on AT&T's behalf, including but not limited to AT&T's employees, agents, contractors, and subcontractors, shall, when working on, within or in the vicinity of BellSouth's poles or conduit system, comply with all applicable federal, state, and local environmental laws, including but not limited to all environmental statutes, ordinances, rules, and regulations.

3.5.9.2

42 U.S.C. §§ 9601 et seq. (the Toxic Substance Control Act); 49 U.S.C. §§ 2601-2629 (the Clean Water Act); 33 U.S.C. §§ 1251 et seq.; and the Safe Drinking Water Act (42 U.S.C. §§ 300f-300j)

on AT&T's behalf, including but not limited to, AT&T's employees, agents, contractors, and subcontractors.

- 3.5.11 Differences in Standards or Specifications. To the extent that there may be differences in any applicable standards or specifications referred to in this Article 3.5, the most stringent standard or specification shall apply.
- 3.5.12 AT&T Solely Responsible for the Condition of Its Facilities. AT&T shall be responsible at all times for the condition of its facilities and its compliance with the requirements, specifications, rules, regulations, ordinances, and laws specified in 3.5.1-3.5.11 above. In this regard, BellSouth shall have no duty to AT&T to inspect or monitor the condition of AT&T's facilities (including but not limited to splices and other facilities connections) located within BellSouth's conduit and ducts or any attachment of AT&T's facilities to BellSouth's poles, anchors, anchor/guy strands or other pole facilities. BellSouth may, however, conduct such inspections and audits of its poles and conduit system as BellSouth determines reasonable or necessary. Such inspection and audits shall be conducted at BellSouth's expense with the exception of (1) follow-up inspection to confirm remedial action after an observed AT&T violation of the requirements of this Agreement; and (2) inspection of AT&T facilities in compliance with a specific mandate of appropriate governmental authority for which inspections the cost shall be borne by AT&T. Either party may audit the other party's compliance with the terms of this Section. Observed safety hazards or imminent facility failure conditions of another party shall be reported to the affected party where such party can be readily identified.
- 3.5.13 Efficient use of Conduit. BellSouth will install inner-ducts to increase duct space in existing conduit as facilities permit. The full compliment of inner-ducts will be installed which can be accommodated under sound engineering principles. The number of inner-ducts which can reasonably be installed will be determined by BellSouth.
- 3.6 **ADDITIONAL LEGAL REQUIREMENTS**
- 3.6.1 **DELETED**
- 3.6.1.1 Licenses granted under this Section authorize AT&T to place facilities in, or attach facilities to, poles, conduits and ducts owned or controlled by BellSouth but do not affect the rights of landowners to control terms and conditions of access to their property.
- 3.6.1.2 AT&T agrees that neither AT&T nor any persons acting on AT&T's behalf, including but not limited to AT&T's employees, agents, contractors, and subcontractors, shall engage in any conduct which damages public or private property in the vicinity of BellSouth's poles or conduit system.

  
FL6/10/97

interferes in any way with the use or enjoyment of public or private property except as expressly permitted by the owner of such property, or creates a hazard or nuisance on such property (including, but not limited to, a hazard or nuisance resulting from any abandonment or failure to remove AT&T's facilities or any construction debris from the property, failure to erect warning signs or barricades as may be necessary to give notice to others of unsafe conditions on the premises while work performed on AT&T's behalf is in progress, or failure to restore the property to a safe condition after such work has been completed)

- 3.6.2 **Required Permits, Certificates and Licenses.** AT&T shall be responsible for obtaining any building permits or certificates from governmental authorities necessary to construct, operate, maintain and remove its facilities on public or private property.
- 3.6.2.1 AT&T shall not attach or place its facilities to or in BellSouth's poles, conduit or duct located on any property for which it or BellSouth has not first obtained all required authorizations.
- 3.6.2.2 BellSouth shall have the right to request evidence that all appropriate authorizations have been obtained. However, such request shall not delay BellSouth's prelicense survey work.
- 3.6.3 **Lawful Purposes.** All facilities placed by AT&T in BellSouth's conduit and ducts or on BellSouth's poles, anchors or anchor/guy strands must serve a lawful purpose and the uses made of AT&T's facilities must comply with all applicable federal, state, and local laws and with all federal, state, and local regulatory rules, regulations, and requirements. In this regard, AT&T shall not utilize any facilities occupying or attached to BellSouth's conduits, ducts or poles for the purpose of providing any services which it is not authorized by law to provide or for the purpose of enabling any other person or entity to provide any such services.
- 3.7 **FACILITIES AND LICENSES**
- 3.7.1 **Licenses Required.** Before placing any facilities in BellSouth's conduits or ducts or attaching any facilities to BellSouth's poles, anchors or anchor/guy strands, AT&T must first apply for and receive a written license from BellSouth. BellSouth shall not unreasonably deny or delay issuance of any license and, in any event, BellSouth shall issue such license within 20 business days from (i) submission of the license application if make-ready work is not required, or (ii) completion of make-ready work, if make-ready work is needed.
- 3.7.2 **DELETED**

  
FL5/10/97

3.7.3 Provision of Records and Information to AT&T

3.7.3.1 In order to obtain information regarding facilities, AT&T shall make a written request to BellSouth, identifying with reasonable specificity the geographic area for which facilities are required, the types and quantities of the required facilities and the required in-service date. In response to such request, BellSouth shall provide AT&T with information regarding the types, quantity and location (which may be provided by provision of route maps and availability of BellSouth poles, conduit and right-of-way located within the geographic area specified by AT&T. Provision of information under the terms of this section shall include the right of AT&T employees or agents to inspect and copy engineering records or drawings which pertain to those facilities within the geographic area identified in AT&T's request. Such inspection and copying shall be done at a time and place mutually agreed upon by the parties. AT&T may elect to be present at any field based survey of facilities identified pursuant to this paragraph and BellSouth shall provide AT&T at least forty-eight (48) hours notice prior to initiating such field survey. AT&T employees or agents shall be permitted to enter BellSouth manholes and inspect such structures to confirm usability and/or evaluate condition of the structure(s) with at least forty-eight (48) hours notice to BellSouth, with a BellSouth representative present and at AT&T's expense.

3.7.3.2 **DELETED**

3.7.3.3 **DELETED**

3.7.4 **MAKE-READY WORK**

3.7.4.1 If performed by BellSouth, make-ready work to accommodate AT&T's facilities shall be included in the normal work load schedule of BellSouth with construction responsibilities in the geographic areas where the relevant poles or conduit systems are located and shall not be entitled to priority, advancement, or preference over other work to be performed by BellSouth in the ordinary course of BellSouth's business.

3.7.4.2 If AT&T desires make-ready work to be performed on an expedited basis and BellSouth agrees to perform the work on such a basis, BellSouth shall recalculate the estimated make-ready charges. If AT&T accepts BellSouth's offer, AT&T shall pay such additional charges.

3.7.4.2.1 **DELETED**

3.7.4.2.2 **DELETED**

3.7.4.2.3 **DELETED**

*lib*  
FL6/10/97

- 3.7.4.3 All charges for make-ready work performed by BellSouth are payable in advance, with the amount of any such advance payment to be due within sixty (60) days after receipt of an invoice from BellSouth.
- 3.7.4.3.1 DELETED
- 3.7.4.3.2 DELETED
- 3.7.4.4 In lieu of obtaining performance of make-ready work by BellSouth, AT&T at its option may arrange for the performance of such work by a contractor certified by BellSouth to work on or in its facilities. Certification shall be granted based upon reasonable and customary criteria employed by BellSouth in the selection of its own contract labor. Notwithstanding any other provisions of this Section, AT&T may not employ a contractor to accomplish make-ready work if BellSouth is likewise precluded from contractor selection under the terms of an applicable joint use agreement.
- 3.7.4.5 BellSouth will issue a license to AT&T at the time all make-ready work necessary to AT&T's attachment or occupancy has been completed.
- 3.7.5 **Application Form and Fees.** To apply for a license under this Section, AT&T shall submit to BellSouth two signed copies of an Application and Conduit Occupancy License form or an Application and Pole Attachment License form. BellSouth will process license applications in the order in which they are received; provided, however, that when AT&T has multiple applications on file with BellSouth, AT&T may designate its desired priority of completion of prelicense surveys and make-ready work with respect to all such applications.
- 3.7.5.1 Each application for a license under this Section shall specify the proposed route of AT&T's facilities and identify the conduits and ducts or poles and pole facilities along the proposed route in which AT&T desires to place or attach its facilities, and describe the physical size, weight and jacket material of the cable which AT&T desires to place in each conduit or duct or the number and type of cables, apparatus enclosures and other facilities which AT&T desires to attach to each pole.
- 3.7.5.2 Each application for a license under this Section shall be accompanied by a proposed (or estimated) construction schedule containing the information specified below in 3.10.1 of this Attachment, and an indication of whether AT&T will, at its option, perform its own make-ready work.
- 3.7.5.3 The parties agree to the establishment of a joint task force, consisting of representatives of AT&T and BellSouth, which will develop all procedures necessary to effectuate the provisions of this Section 3.7. Matters to be addressed by the joint task force include, without limitation, the

development of time frames for BellSouth's provision of record information and availability determinations and for the processing of license applications, the establishment of guidelines to address the number of AT&T applications which may be processed simultaneously by BellSouth and any other matters necessary to effectuate the provisions of this Section. The parties agree to negotiate in good faith to achieve agreement on all matters presented to the joint task force and to reduce said agreement to writing within sixty (60) calendar days from the Effective Date of this Agreement.

3.7.6 Multiple Cables, Multiple Services, Lashing or Placing Additional Cables and Replacement of Facilities. AT&T may include multiple cable in a single license application and multiple services (e.g., CATV and non-CATV services) may be provided by AT&T in the same cable sheath. AT&T's lashing additional cable to existing facilities and placing additional cables in conduits or ducts already occupied by AT&T's facilities shall be permitted, and no additional fees will be applied; provided, however, that if AT&T desires to lash additional cable to existing facilities of a third party AT&T shall provide BellSouth with reasonable notice, and shall obtain written permission from the owner of the existing facilities. If BellSouth determines that the requested lashing would violate safety requirements, BellSouth shall provide written notice to AT&T within a reasonable time specifying in detail BellSouth's findings. If AT&T disagrees with BellSouth's determination, the matter may be submitted to the Alternative Dispute Resolution Process, described in Attachment 1. If AT&T desires to place additional cables in conduits or ducts which are already occupied, or to replace existing facilities with new facilities substantially different from those described in licenses in effect, AT&T must apply for a acquire a new license specifically describing the physical size, weight and jacket material of the cable to be placed in BellSouth's conduits and ducts or the physical size, weight, and jacket type of cables and the size and weight of apparatus enclosures and other facilities to be attached to BellSouth's poles.

3.7.7 **DELETED**

3.7.8 Single Point of Contact. Each party hereby designates the employees named below as their single point of contact for any and all purposes of this Section, including, but not limited to, processing licenses and applications and providing records and information. Each party may at any time designate a new point of contact by giving written notice of such change.

[Title of Single Point of Contact]  
[Address, phone and fax]

UB  
FL6/10/97

Anything to the contrary herein notwithstanding, notification of an emergency condition which poses an immediate threat to life or property or substantially impairs provisioning of BellSouth's service shall be reported to BellSouth by contacting:

[Name and Title]

[Address, phone and fax]

- 3.7.9 DELETED
- 3.8 PROCESSING OF APPLICATIONS (INCLUDING PRELICENSE SURVEYS AND FIELD INSPECTIONS)
- 3.8.1 AT&T's Priorities. When AT&T has multiple applications on file with BellSouth, AT&T shall designate its desired priority of completion of prelicense surveys and make-ready work with respect to all such applications.
- 3.8.2 Prelicense Survey. After AT&T has submitted its written application for a license, a prelicense survey (including a field inspection) will be performed by either party, in the company of a representative of the other party as mutually agreed, to determine whether BellSouth's poles, anchors and anchor/guy strands, or conduit system, in their present condition, can accommodate AT&T's facilities, without substantially interfering with the ability of BellSouth or any other authorized person or entity to use or access the pole, anchor or anchor/guy strand or any portion of BellSouth's conduit system or facilities attached to BellSouth's pole or placed within or connected to BellSouth's conduit system. If AT&T gives its prior written consent in writing, the determination of duct availability may include the "rodding" of ducts at AT&T's expense.
- 3.8.2.1 The purpose of the prelicense survey is to determine whether AT&T's proposed attachments to BellSouth's poles or occupancy of BellSouth's conduit and ducts will substantially interfere with use of BellSouth's facilities by BellSouth and others with facilities occupying, connected or attached to BellSouth's pole or conduit system; and to provide information to AT&T for its determination of whether the pole, anchor, anchor/guy strand, conduit, duct, or right-of-way is suitable for its use.
- 3.8.2.2 Based on information provided by BellSouth, AT&T shall determine whether BellSouth's pole, anchor, anchor/guy strand, conduit and duct facilities are suitable to meet AT&T's needs.
- 3.8.2.3 BellSouth may not unreasonably refuse to continue to process an application based on BellSouth's determination that AT&T's proposed use of BellSouth's facilities will not be in compliance with applicable requirements, specifications, rules, regulations, ordinances, and laws.

  
FL6/10/97



The parties shall submit the issue for resolution under the Alternative Dispute Resolution procedures specified in Attachment 1 to the Agreement. AT&T shall be responsible for making its own, independent determination that its use of such facilities will be in compliance with such requirements, specifications, rules, regulations, ordinances and laws. AT&T acknowledges that BellSouth is not explicitly or implicitly warranting to AT&T that AT&T's proposed use of BellSouth's facilities will be in compliance with applicable requirements, specifications, rules, regulations, ordinances, and laws.

3.8.3 Environmental, health and safety inspections. Within a reasonable time period after AT&T has submitted its written application for a license, BellSouth shall provide AT&T with such information about environmental, health and safety inspections that is equal to the information that BellSouth retains and provides for the use of its employees who access rights of way, conduits and pole attachments. Nothing in this Section 3.8.3 is intended to create any additional liabilities that might otherwise exist with respect to environmental, health and safety inspections and to notices thereof.

3.8.4 Administrative Processing. The administrative processing portion of the prelicense survey (which includes without limitation processing the application, preparing make-ready work orders, notifying joint users and other persons and entities of work requirements and schedules, coordinating the relocation/rearrangement of BellSouth and/or other licensed facilities) will be performed by BellSouth at AT&T's expense. Anything to the contrary herein notwithstanding, BellSouth shall bear no responsibility for the relocation, rearrangement or removal of facilities used for the transmission or distribution of electric power.

3.8.5 **DELETED**

### 3.9 **ISSUANCE OF LICENSES**

3.9.1 Obligation to Issue Licenses. BellSouth shall issue a license to AT&T pursuant to this 3.9. BellSouth and AT&T acknowledge that each application for a license shall be evaluated on an individual basis. Nothing contained in this section shall be construed as abridging any independent pole attachment rights or conduit or duct access rights which AT&T may have under the provisions of any applicable federal or state laws or regulations governing access to BellSouth's poles, conduits and ducts, to the extent the same are not inconsistent with the Telecommunications Act of 1996. Each license issued hereunder shall be for an indefinite term, subject to AT&T's compliance with the provisions

UB

FL6/10/97

applicable to such license and further subject to AT&T's right to terminate such license at any time for any reason upon at least thirty (30) days prior written notice.

- 3.9 Issuance of Licenses When No Make-Ready Work is Required. If BellSouth determines that no make-ready work is required, BellSouth shall approve applications for pole attachment and conduit occupancy licenses and issue such licenses within twenty (20) business days of receipt of AT&T's application.
- 3.9.3 Multiple Applications. AT&T acknowledges that multiple parties including BellSouth may seek to place their facilities in BellSouth's conduit and ducts at or about the same time, that the make-ready work required to prepare BellSouth's facilities to accommodate multiple applicants may differ from the make-ready work required to accommodate a single applicant, that issues relating to the proper apportionment of costs arise in multi-applicant situations that do not arise in single-applicant situations, and that cooperation and negotiations between all applicants and BellSouth may be necessary to resolve disputes involving multiple applications for permission to place facilities in/on the same pole, conduit, duct, or right-of-way.
- 3.9.3.1 All applications will be processed on a first-come, first served basis.
- 3.9.3.2 DELETED
- 3.9.3.3 DELETED
- 3.9.4 Agreement to Pay for All Make-Ready Work Completed. AT&T's submission of written authorization for make-ready work shall also constitute AT&T's agreement to pay additional cost-based charges, if any, for completed make-ready work as provided in Article 3.7.4.3.
- 3.9.5 Payments to Others for Expenses Incurred in Transferring or Arranging Their Facilities. AT&T shall make arrangements with the owners of other facilities located in or connected to BellSouth's conduit system or attached to BellSouth's poles, anchors or anchor/guy strands regarding reimbursement for any expenses incurred by them in transferring or rearranging their facilities to accommodate the placement or attachment of AT&T's facilities in or to BellSouth's structures.
- 3.9.6 DELETED
- 3.9.7 DELETED
- 3.9.7.1 DELETED

3.9.7.2 DELETED

3.9.7.3 DELETED

3.9.7.4 DELETED

3.9.7.5 DELETED

3.9.8 Make-Ready Work on an Expedited Basis.

3.9.8.1.1 If AT&T requests that make-ready work be performed on an expedited basis, AT&T shall so advise BellSouth at the earliest opportunity

3.9.8.1.2 If AT&T is willing to authorize BellSouth to perform make-ready work on an expedited basis, and if BellSouth agrees to perform the work on such a basis, BellSouth shall recalculate the estimated make-ready charges. If AT&T accepts BellSouth's offer, upon completion of the make-ready work AT&T shall pay such additional charges, if any.

3.9.9 License. When AT&T's application for a pole attachment or conduit occupancy license is approved, and all required make-ready work completed, BellSouth will execute and return a signed authorization to AT&T, as appropriate, authorizing AT&T to attach or place the specified facilities on BellSouth's poles or in BellSouth's conduit or ducts.

3.9.9.1 Each license issued under this Section shall authorize AT&T to attach to BellSouth's poles or place or maintain in BellSouth's conduit or ducts only those facilities specifically described in the license, and no others.

3.9.9.2 Except as expressly stated to the contrary in individual licenses issued hereunder, each license issued pursuant to this Section shall incorporate all terms and conditions of this Section whether or not such terms or conditions are expressly incorporated by reference on the face of the license itself.

3.10 **CONSTRUCTION OF AT&T'S FACILITIES**

3.10.1 Construction Schedule. AT&T shall submit with AT&T's license application a proposed or estimated construction schedule. Promptly after the issuance of a license permitting AT&T to attach facilities to BellSouth's poles or place facilities in BellSouth's conduit or ducts, AT&T shall provide BellSouth with an updated construction schedule and shall thereafter keep BellSouth informed of significant anticipated changes in the construction schedule. Construction schedules required by this Section shall include, at a minimum, the following information:

- 3.10.1.1 The name, title, business address, and business telephone number of the manager responsible for construction of the facilities;
- 3.10.1.2 The names of each contractor and subcontractor which will be involved in the construction activities;
- 3.10.1.3 The estimated dates when construction will begin and end, and
- 3.10.1.4 The approximate dates when AT&T or persons acting on AT&T's behalf will be performing construction work in connection with the placement of AT&T's facilities in BellSouth's conduit or ducts.
- 3.10.2 Additional Pre-construction Procedures for Facilities Placed in Conduit System. The following procedures shall apply before AT&T places facilities in BellSouth's conduit system:
- 3.10.2.1 AT&T shall give written notice of the type of facilities which are to be placed; and
- 3.10.2.2 BellSouth shall provide to AT&T space in manholes for racking and storage of up to fifty (50) feet of cable, provided space is available.
- 3.10.3 **DELETED**
- 3.10.4 BellSouth Not Responsible for Constructing or Placing Facilities. BellSouth shall have no obligation to construct any facilities for AT&T or to attach AT&T's facilities to, or place AT&T's facilities in, BellSouth's poles or conduit system, except as may be necessary to facilitate the interconnection of unbundled network elements or except to the extent expressly provided in this Section, any license issued hereunder, or by the Telecommunications Act of 1996 or any other applicable law.
- 3.10.5 AT&T Responsible for Constructing, Attaching and Placing Facilities. Except where otherwise mutually agreed by AT&T and BellSouth, AT&T shall be responsible for constructing its own facilities and attaching those facilities to, or placing them in BellSouth's poles, conduit or ducts at AT&T's sole cost and expense. AT&T shall be solely responsible for paying all persons and entities who provide materials, labor, access to real or personal property, or other goods or services in connection with the construction and placement of AT&T's facilities and for directing the activities of all persons acting on AT&T's behalf while they are physically present on BellSouth's pole, in any part of BellSouth's conduit system or in the vicinity of BellSouth's poles or conduit system.
- 3.10.6 Compliance with Applicable Standards, Health and Safety Requirements, and Other Legal Requirements. AT&T shall construct its facilities in

accordance with the provisions of this Section and all licenses issued hereunder.

- 3.10.6.1 AT&T shall construct, attach and place its facilities in compliance with all Requirements and Specifications set forth above in 3.5 of this Attachment
- 3.10.6.2 AT&T shall satisfy all Legal Requirements set forth above in 3.6 of this Section.
- 3.10.6.3 AT&T shall not permit any person acting on AT&T's behalf to perform any work on BellSouth's poles or within BellSouth's conduit system without first verifying, to the extent practicable, on each date when such work is to be performed, that the condition of the pole or conduit system is suitable for the work to be performed. If AT&T or any person working on AT&T's behalf determines that the condition of the pole or conduit system is not suitable for the work to be performed, AT&T shall notify BellSouth of the condition of the pole or conduit system in question and shall not proceed with construction activities until AT&T is satisfied that the work can be safely performed.
- 3.10.7 Construction Notices. If requested to do so, AT&T shall provide BellSouth with information to reasonably assure BellSouth that construction has been performed in accordance with all applicable standards and requirements.
- 3.10.8 Points for Attachment. BellSouth shall specify, using the same selection criteria it uses for its own operating company, the point of attachment of each pole or anchor to be occupied by AT&T's facilities. When the facilities of more than one applicant are involved, BellSouth will attempt, to the extent practicable, to designate the same relative position on each pole or anchor for each applicant's facilities.
- 3.10.9 Manhole and Conduit Break-Outs. AT&T shall be permitted to add conduit ports to BellSouth manholes when existing conduits do not provide the pathway connectivity needed by AT&T; provided the structural integrity of the manhole is maintained, and sound engineering judgment is employed.
- 3.11 **USE AND ROUTINE MAINTENANCE OF AT&T'S FACILITIES**
- 3.11.1 Use of AT&T's Facilities. Each license granted under this Section authorizes AT&T to have access to AT&T's facilities on or in BellSouth's poles, conduits and ducts as needed for the purpose of serving AT&T's customers, including, but not limited to, powering electronics, monitoring facilities, or transporting signaling.

- 3.11.2 Routine Maintenance of AT&T's Facilities. Each license granted under this Section authorizes AT&T to engage in routine maintenance of AT&T's facilities located on or in BellSouth's poles, conduits, ducts and ROW pursuant to such license. AT&T shall give reasonable notice to the affected public authority or private landowner as appropriate before commencing the construction or installation of its attachments or making any material alterations thereto. AT&T shall give reasonable notice to BellSouth before performing any work, whether or not of a routine nature, in BellSouth's conduit system.
- 3.11.3 AT&T Responsible for Maintenance of AT&T's Facilities. AT&T shall maintain its facilities in accordance with the provisions of this Section (including but not limited to all Requirements set forth above in 3.5 of this Section ) and all licenses issued hereunder. AT&T shall be solely responsible for paying all persons and entities who provide materials, labor, access to real or personal property, or other goods or services in connection with the maintenance of AT&T's facilities and for directing the activities of all persons acting on AT&T's behalf while they are physically present on BellSouth's poles, within BellSouth's conduit system or in the immediate vicinity of such poles or conduit system.
- 3.11.4 BellSouth Not Responsible for Maintaining AT&T's Facilities. BellSouth shall have no obligation to maintain any facilities which AT&T has attached or connected to, or placed in, BellSouth's poles, conduits, ducts or any portion of BellSouth's conduit system, except to the extent expressly provided by the provisions of this Section or any license issued hereunder, or by the Telecommunications Act of 1996 or other applicable laws, rules or regulations.
- 3.11.5 Information Concerning the Maintenance of AT&T's Facilities. Promptly after the issuance of a license permitting AT&T to attach facilities to, or place facilities in BellSouth's poles, conduits or ducts, AT&T shall provide BellSouth with the name, title, business address, and business telephone number of the manager responsible for routine maintenance of AT&T's facilities, and shall thereafter notify BellSouth of changes to such information. The manager responsible for routine maintenance of AT&T's facilities shall, on BellSouth's request, identify any contractor, subcontractor, or other person performing maintenance activities on AT&T's behalf at a specified site and shall, on BellSouth's request, provide such additional documentation relating to the maintenance of AT&T's facilities as reasonably necessary to demonstrate that AT&T and all persons acting on AT&T's behalf are complying with the requirements of this Section and licenses issued hereunder.

- 3.11.6 Identification of Personnel Authorized to Have Access to AT&T's Facilities  
All personnel authorized to have access to AT&T's facilities shall, while working on BellSouth's poles, in its conduit system or ducts or in the vicinity of such poles, ducts or conduit systems, carry with them suitable identification and shall, upon the request of any BellSouth employee, produce such identification.
- 3.12 **MODIFICATION AND REPLACEMENT OF AT&T'S FACILITIES**
- 3.12.1 Notification of Planned Modification or Replacement of Facilities. AT&T shall, when practicable, notify BellSouth in writing at least 60 days before adding to, relocating, replacing or otherwise modifying its facilities attached to a BellSouth pole, anchor or anchor/guy strand or located in any BellSouth conduit or duct. The notice shall contain sufficient information to enable BellSouth to determine whether the proposed addition, relocation, replacement, or modification is permitted under AT&T's present license or requires a new or amended license.
- 3.12.2 New or Amended License Required. A new or amended license will be required if the proposed addition, relocation, replacement, or modification:
- 3.12.2.1 Requires that AT&T use additional space on BellSouth's poles or in its conduits or ducts (including but not limited to any additional ducts, inner ducts, or substantial space in any handhole or manhole) on either a temporary or permanent basis; or
- 3.12.2.2 Results in the size or location of AT&T's facilities on BellSouth's poles or in its conduit or ducts being appreciably different from those described and authorized in AT&T's present license (e.g. different duct or size increase causing a need to re-calculate storm loadings, guying, or pole class).
- 3.13 **REARRANGEMENT OF FACILITIES AT THE REQUEST OF ANOTHER**
- 3.13.1 Make-Ready Work at the Request of AT&T. If, prior to the issuance of a license, AT&T determines that any pole, anchor, anchor/guy strand, conduit or duct is inadequate to accommodate AT&T's proposed pole attachment or conduit occupancy or that it will be necessary or desirable for BellSouth or any other person or entity to rearrange existing facilities or structures to accommodate AT&T, AT&T shall promptly advise BellSouth of the make-ready work it believes necessary to enable the accommodation of AT&T's facilities.
- 3.13.1.1 BellSouth shall determine, in the exercise of sound engineering judgment, whether or what such make-ready work is necessary or possible. In

determining whether make-ready work is necessary BellSouth shall endeavor to minimize its costs. If it is determined that such make-ready work is required, within twenty (20) business days of such determination BellSouth shall provide AT&T with the estimated costs for make-ready work and a Make Ready Due Date.

- 3.13.1.2 AT&T shall be solely responsible for negotiating with persons or entities other than BellSouth for the rearrangement of such persons' or entities' facilities or structures and, except where such rearrangement is for the benefit of BellSouth and/or other licensees as well as AT&T, shall be solely responsible for paying all charges attributable to the rearrangement of such facilities; provided, however, that if facilities rearrangements require new licenses from BellSouth, BellSouth shall issue such licenses in conjunction with the issuance of the applied-for license to AT&T.
- 3.13.2 Rearrangement of AT&T's Facilities at BellSouth's Request. AT&T acknowledges that, from time to time, it may be necessary or desirable for BellSouth to change out poles, relocate, reconstruct, or modify portions of its conduit system or rearrange facilities contained therein or connected thereto and that such changes may be necessitated by BellSouth's business needs or authorized application of another entity seeking access to BellSouth's poles or conduit systems. AT&T agrees that AT&T will, upon BellSouth's request, and at BellSouth's expense, but at no cost to AT&T, participate with BellSouth (and other licensees) in the relocation, reconstruction, or modification of BellSouth's conduit system or facilities rearrangement. AT&T acknowledges that, from time to time, it may be necessary or desirable for BellSouth to change out poles, relocate, reconstruct, or modify portions of its conduit system or rearrange facilities contained therein or connected thereto as a result of an order by a municipality or other governmental authority. AT&T shall, upon BellSouth's request, participate with BellSouth (and other licensees) in the relocation, reconstruction, or modification of BellSouth's conduit system or facilities rearrangement and pay its proportionate share of any costs of such relocation, reconstruction, or modification that are not reimbursed by such municipality or governmental authority.
- 3.13.2.1 AT&T shall make all rearrangements of its facilities within such period of time as is jointly deemed reasonable by the parties based on the amount of rearrangements necessary and a desire to minimize chances for service interruption or facility-based service denial to an AT&T customer.
- 3.13.2.2 If AT&T fails to make the required rearrangements within the time prescribed in 3.13.2.1 preceding or within such extended periods of time as may be granted by BellSouth in writing, BellSouth may perform such rearrangements with written notice to AT&T, and AT&T shall reimburse



BellSouth for actual costs and expenses incurred by BellSouth in connection with the rearrangement of AT&T's facilities, provided, however, that nothing contained in this Section or any license issued hereunder shall be construed as requiring AT&T to bear any expenses which, under the Telecommunications Act of 1996 or other applicable federal or state laws or regulations, are to be allocated to persons or entities other than AT&T, and provided further, however, that AT&T shall have no responsibility for rearrangement costs and expenses relating to rearrangements performed for the purpose of meeting BellSouth's needs

**3.14 EMERGENCY REPAIRS AND POLE REPLACEMENTS**

- 3.14.1 Within sixty (60) days after the Effective Date of this Agreement, BellSouth and AT&T shall mutually agree on a non-discriminatory priority method to access BellSouth poles, conduit and ROW in emergency situations.
- 3.14.2 AT&T Responsible for Emergency Repairs to its Own Facilities. In general, AT&T shall be responsible for making emergency repairs to its own facilities and for formulating appropriate plans and practices which will enable it to make such emergency repairs. BellSouth shall be under no obligation to perform any repair or service restoration work of any kind with respect to AT&T's facilities.
- 3.14.3 DELETED
- 3.14.4 DELETED
- 3.14.5 DELETED
- 3.14.6 DELETED
- 3.14.6.1 DELETED
- 3.14.6.2 DELETED
- 3.14.6.3 DELETED
- 3.14.7 DELETED
- 3.14.7.1 DELETED
- 3.14.7.2 DELETED
- 3.14.7.3 DELETED
- 3.14.7.4 DELETED

UB

FL6/10/97

3.14.8 DELETED

3.14.8.1 DELETED

3.14.8.2 DELETED

3.14.8.3 DELETED

3.14.8.4 DELETED

3.15 INSPECTION BY BELLSOUTH OF AT&T'S FACILITIES

3.15.1 BellSouth's Right to Make Periodic or Spot Inspections. BellSouth shall have the right to make periodic or spot inspections at any time of any part of AT&T's facilities attached to BellSouth's poles, anchors or anchor/guy strands or occupying any BellSouth conduit or duct for the limited purpose of determining whether AT&T's facilities are in compliance with the terms of this Section and licenses hereunder, provided that such inspections must be non-invasive (e.g., no splice cases may be opened).

3.15.1.1 BellSouth will give AT&T advance written notice of such inspections, and AT&T shall have the right to have a representative attend such inspections, except in those instances where safety considerations justify the need for such inspection without the delay of waiting until written notice has been forwarded to AT&T.

3.15.1.2 Such inspections shall be conducted at BellSouth's expense. Expense, provided, however, that AT&T shall bear the cost of inspections as delineated in 3.5.12.

3.15.2 DELETED

3.15.3 No Duty to AT&T. Neither the act of inspection by BellSouth of AT&T's facilities nor any failure to inspect such facilities shall operate to impose on BellSouth any liability of any kind whatsoever or to relieve AT&T of any responsibility, obligations or liability under this Section or otherwise existing.

3.16 NOTICE OF NONCOMPLIANCE

3.16.1 Notice of Noncompliance. If, at any time, BellSouth determines that AT&T's facilities or any part thereof have not been placed or maintained or are not being used in accordance with the requirements of this Attachment 3, BellSouth may send written notice to AT&T specifying the alleged noncompliance. AT&T agrees to acknowledge receipt of the notice as soon as practicable. If AT&T does not dispute BellSouth's assertion that such facilities are not in compliance, AT&T agrees to

UPB  
FL6/10/97

provide BellSouth with a schedule for bringing such facilities into compliance, to bring the facilities into compliance within a reasonable time, and to notify BellSouth in writing when the facilities have been brought into compliance.

- 3.16.2 **Disputes over Alleged Noncompliance.** If AT&T disputes BellSouth's assertion that AT&T's facilities are not in compliance, AT&T shall notify BellSouth in writing of the basis for AT&T's assertion that its facilities are in compliance.
- 3.16.3 **Failure to Bring Facilities into Compliance.** If AT&T has not brought the facilities into compliance within a reasonable time or provided BellSouth with proof sufficient to persuade BellSouth that BellSouth erred in asserting that the facilities were not in compliance, and if BellSouth determines in good faith that the alleged noncompliance causes or is likely to cause material damage to BellSouth's facilities or those of others users, BellSouth may, at its option and AT&T's expense, take such non-service affecting steps as may be required to bring AT&T's facilities into compliance, including but not limited to correcting any conditions which do not meet the specifications of 3.5 of this Section .
- 3.16.4 **Correction of Conditions by BellSouth.** If BellSouth elects to bring AT&T's facilities into compliance as provided by 3.16.3 of this Section, the provisions of this Section shall apply.
- 3.16.4.1 BellSouth will, whenever practicable, notify AT&T in writing before performing such work. The written notice shall describe the nature of the work to be performed and BellSouth's schedule for performing the work.
- 3.16.4.2 If AT&T's facilities have become detached or partially detached from supporting racks or wall supports located within a BellSouth manhole, BellSouth may, at AT&T's expense, reattach them but shall not be obligated to do so. If BellSouth does not reattach AT&T's facilities, BellSouth shall endeavor to arrange with AT&T for the reattachment of any facilities affected.
- 3.16.4.3 BellSouth shall, as soon as practicable after performing the work, advise AT&T in writing of the work performed or action taken. Upon receiving such notice, AT&T shall inspect the facilities and take such steps as AT&T may deem necessary to insure that the facilities meet AT&T's performance requirements.
- 3.16.5 **AT&T to Bear Expenses.** AT&T shall bear all expenses arising out of or in connection with any work performed to bring AT&T's facilities into compliance with this Section; provided, however that nothing contained in this Section or any license issued hereunder shall be construed as

requiring AT&T to bear any expenses which, under applicable federal or state laws or regulations, must be borne by persons or entities other than AT&T. Disputes between the parties concerning charges by BellSouth to AT&T pursuant to 3.16.3 shall be resolved in accordance with the Alternative Dispute Resolution procedures set forth in Attachment 1 of the Agreement.

3.17 **UNAUTHORIZED OCCUPANCY OR UTILIZATION OF BELLSOUTH'S FACILITIES**

3.17.1 **Licensing or Removal of Unauthorized Attachments.** If any of AT&T's attachments shall be found attached to pole(s) or occupying conduit systems for which no license is outstanding, BellSouth, without prejudice to its other rights or remedies under this Agreement, including termination of licenses, may impose a charge and require AT&T to submit in writing, within thirty (30) days after receipt of written notification from BellSouth of the unauthorized attachment or conduit occupancy, a pole attachment or conduit occupancy license application. If such application is not received by BellSouth within the specified time period, AT&T may be required at BellSouth's option to remove its unauthorized attachment or occupancy within sixty (60) days of the final date for submitting the required application, or BellSouth may at BellSouth's option remove AT&T's facilities without liability, and the expense of such removal shall be borne by AT&T. Charges for any such unauthorized occupancy shall be equal to the applicable license fees and charges which would have been payable from and after the date such facilities were first placed on BellSouth's poles or in BellSouth's conduit system, if AT&T provides reasonable documentation of such placement. If AT&T is unable to provide such reasonable documentation the matter may be submitted to the Alternative Dispute Resolution Process, described in Attachment 1. If BellSouth prevails in such Alternative Dispute Resolution, then AT&T will pay two years worth of the applicable charges.

3.17.2 **DELETED**

3.17.2.1 **DELETED**

3.17.2.2 **DELETED**

3.17.2.3 Nothing contained in the Agreement or any license issued hereunder shall be construed as requiring AT&T to bear any expenses which, under applicable federal or state laws or regulations, must be borne by persons or entities other than AT&T.

3.17.3 **Prompt Payment of Applicable Fees and Charges.** Fees and charges for pole attachments and conduit system occupancies, as specified herein

*JB*  
FL6/10/97

and as modified from time to time, shall be due and payable immediately whether or not AT&T is permitted to continue the pole attachment or conduit occupancy.

3.17.4 No Implied Waiver or Ratification of Unauthorized Use. No act or failure to act by BellSouth with regard to said unlicensed use shall be deemed as a ratification of the unlicensed use; and if any license should be subsequently issued, said license shall not operate retroactively or constitute a waiver by BellSouth of any of its rights or privileges under this Agreement or otherwise; provided, however, that AT&T shall be subject to all liabilities, obligations and responsibilities of this Agreement in regard to said unauthorized use from its inception.

3.17.5 DELETED

3.18 REMOVAL OF AT&T'S FACILITIES

3.18.1 DELETED

3.18.1.1 DELETED

3.18.1.2 DELETED

3.18.1.3 DELETED

3.18.1.4 DELETED

3.18.1.5 DELETED

3.18.2 DELETED

3.18.3 DELETED

3.18.4 DELETED

3.18.5 DELETED

3.18.6 DELETED

3.18.7 DELETED

3.18.7.1 DELETED

3.18.7.2 DELETED

3.18.7.3 DELETED

3.18.7.4 DELETED

- 3.18.7.5 DELETED
- 3.18.8 DELETED
- 3.18.9 DELETED
- 3.18.10 DELETED
- 3.18.10.1 DELETED
- 3.18.10.2 DELETED
- 3.18.10.3 DELETED
- 3.18.11 DELETED
- 3.18.11.1 DELETED
- 3.18.11.2 DELETED
- 3.18.11.3 DELETED
- 3.18.12 DELETED
- 3.18.12.1 DELETED
- 3.18.12.2 DELETED
- 3.18.13 **Pole Attachments.** AT&T, at its expense, will remove its attachments from any of BellSouth's poles within thirty (30) days after termination of the license covering such attachments. If AT&T fails to remove its attachments within such thirty (30) day period, BellSouth shall have the right to remove such attachments at AT&T's expense and without any liability on the part of BellSouth for damage or injury to AT&T's attachments unless caused by the negligence or intentional misconduct of BellSouth.
- 3.18.14 **Conduit Occupancy.** AT&T, at its expense, will remove its communications facilities from a conduit system within sixty (60) days after.
  - 3.18.14.1 Termination of the license covering such conduit occupancy; or
  - 3.18.14.2 The date AT&T replaces its existing facilities in one duct with substitute facilities in another duct.
- 3.18.15 If AT&T fails to remove its facilities within the specified period, BellSouth shall have the right to remove such facilities at AT&T's expense and

UB  
FL6/10/97

without any liability on the part of BellSouth for damage or injury to such facilities unless caused by the negligence or intentional misconduct of BellSouth.

- 3.18.16 Continuing Responsibility for Fees and Charges. AT&T shall remain liable for and pay to BellSouth all fees and charges pursuant to provisions of this Agreement until all of AT&T's facilities are physically removed from BellSouth's poles or conduit system.
- 3.19 **FEES, CHARGES, AND BILLING**
- 3.19.1 **DELETED**
- 3.19.2 **DELETED**
- 3.19.3 **DELETED**
- 3.19.4 **DELETED**
- 3.19.5 License Charges. License charges commence on the first day of the calendar month following the date a license is issued. Such charges cease as of the final day of the calendar month preceding the month in which the attachment or occupancy is physically removed or the utilization is discontinued. A one-month minimum charge is applicable to all licenses.
- 3.19.6 Notice of Rate and Computation of Charges. On or about November 1 of each year, BellSouth will notify AT&T by certified mail, return receipt requested, of the rental rate and pole transfer rate to be applied in the subsequent calendar year. The letter of notification shall be incorporated in, and governed by, the terms and conditions of this Agreement. Attachment and occupancy rates shall be applied to the number of pole(s) and duct feet of conduit for which licenses have been issued before December 1 of each calendar year. Charges for attachment(s) and occupancy which commenced during the preceding twelve (12) month period will be prorated accordingly.
- 3.20 **ADVANCE PAYMENT AND IMPUTATION**
- 3.20.1 **DELETED**
- 3.20.2 Attachment and Occupancy Fees. Fees for pole attachment and conduit occupancy shall be based on the facilities for which licenses have been issued as of the date of billing by BellSouth, shall be computed as set forth in Attachment 4 of this Agreement and shall be payable annually.
- 3.20.2.1 **DELETED**

of the next level manager from the BellSouth Director and  
continue escalating until a resolution is reached.

*EB*

FL4/2/97



TABLE OF CONTENTS

PROVISION OF CUSTOMER USAGE DATA ..... 3

1. Introduction ..... 3

2. General Requirements for Recorded Usage Data ..... 3

3. Usage Data Specifications ..... 3

4. Recorded Usage Data Format ..... 4

5. Recorded Usage Data Reporting Requirements ..... 4

6. Recording Failures ..... 5

7. Charges ..... 7

8. Local Account Maintenance ..... 7

9. Incollect/Outcollect Procedures ..... 7

APPENDIX I ..... 14

APPENDIX II ..... 15

SECTION I: SCOPE ..... 16

SECTION II: RECORDED USAGE TO BE TRANSMITTED TO AT&T ..... 18

1. General ..... 18

2. Usage To Be Transferred To AT&T ..... 18

3. AT&T Usage (Recording "Flat Rate" Service) ..... 18

SECTION III: BELLSOUTH TO AT&T USAGE FEED ..... 20

1. General ..... 20

2. Detailed EMR Record Edits ..... 20

3. Duplicate Record Checks ..... 20

4. BellSouth to AT&T Usage Feed ..... 20

SECTION IV: AT&T PROCESSING REQUIREMENTS 25

1. General..... 25

2. AT&T Rating Process..... 25

SECTION V: TEST PLANS AND ACTIVITIES 27

1. General..... 27

2. Interface Testing..... 27

3. Operational Test..... 27

4. Test File..... 27

SECTION VI: POST DEPLOYMENT ACTIVITIES 29

1. General..... 29

2. Control Maintenance And Review..... 29

3. BellSouth Software Changes..... 35

4. AT&T Software Changes..... 35

5. Post Conversion Test Plan..... 35

SECTION VII-SUBAPPENDICES..... 38

## PROVISION OF CUSTOMER USAGE DATA

### 1. Introduction

1.1 This Attachment sets forth the terms and conditions for BellSouth's provision of Recorded Usage Data (as defined in this Attachment) to AT&T. At AT&T's request, Recorded Usage Data shall be provided by BellSouth to AT&T when AT&T purchases Network Elements, Combinations, or Local Services from BellSouth.

### 2. General Requirements for Recorded Usage Data

2.1 BellSouth shall provide AT&T with Recorded Usage Data in accordance with this Attachment 7.

2.2 **DELETED**

2.3 BellSouth shall retain Recorded Usage Data in accordance with applicable law and regulation.

### 3. Usage Data Specifications

3.1 BellSouth will record all usage originating from AT&T Customers using BellSouth-provided Elements or Local Services. Recorded Usage Data includes, but is not limited to, the following categories of information:

- Completed Calls
- Use of Feature Activations for Call Return, Repeat Dialing, and Usage Sensitive Three Way Calling
- Rated Calls To Information Providers Reached Via BellSouth Facilities
- Calls To Directory Assistance Where BellSouth Provides Such Service To An AT&T Customer
- Calls Completed Via BellSouth-Provided Operator Services Where BellSouth Provides Such Service To AT&T's Local Service Customer originating from AT&T's customer or billed to AT&T
- For BellSouth-Provided Centrex Service, Station Level Detail
- Records Shall Include Complete Call Detail And Complete Timing Information

3.2 BellSouth shall provide to AT&T Recorded Usage Data for AT&T Customers only. BellSouth will not submit other carrier local usage data as part of the AT&T Recorded Usage Data.

3.3 **DELETED**

3.4 DELETED

3.5 End user customer usage records and station level detail records shall be in packs in accordance with EMR standards.

4. Recorded Usage Data Format

4.1 BellSouth will provide Recorded Usage Data in the EMR format and by category, group and record type, as specified in the AT&T Customer Usage Data Transfer Requirements, ("Data Requirements"), which is attached hereto and incorporated herein as Appendix II. BellSouth will provide the usage in accordance with BellCore EMR Standards.

4.2 BellSouth shall include the Working Telephone Number (WTN) of the call originator on each EMR call record.

4.3 End user customer usage records and station level detail records shall be in packs in accordance with EMR standards.

5. Recorded Usage Data Reporting Requirements

5.1 BellSouth shall segregate and organize the Recorded Usage Data in accordance with AT&T's instructions.

5.2 BellSouth shall provide Recorded Usage Data to one AT&T biller location as designated by AT&T.

5.3 BellSouth shall transmit Data Requirements formatted Recorded Usage Data to AT&T via CONNECT:Direct as designated by AT&T. The charge for transmitting the Data Requirements is set forth in Part IV of this Agreement.

5.4 AT&T will test and certify the CONNECT:Direct interface to ensure the accurate receipt of Recorded Usage Data. BellSouth shall make any changes necessary to pass the AT&T CONNECT:Direct certification process.

5.5 BellSouth shall provide Recorded Usage Data to AT&T on a schedule to be determined by the Parties once a day for each regular business day, five days a week except holidays as designated by AT&T.

5.6 BellSouth will establish a single point of contact to respond to AT&T call usage, data error, and record transmission inquiries.

5.7 The Recorded Usage Data EMR format, content, and transmission process will be tested as specified by AT&T.

- 6.3 When requested by AT&T for security purposes, BellSouth shall use its best efforts to provide AT&T with Recorded Usage Data within the time frame specified by AT&T. If not available in EMR format, the Recorded Usage Data may be provided in AMA format.

6 **Recording Failures**

- 6.1 When BellSouth records usage and fails to record messages, regardless of whether AT&T or BellSouth are performing the billing function, BellSouth shall notify AT&T of the amount of estimated AT&T revenue in accordance with Section 6.3. BellSouth shall compensate AT&T for the net loss to AT&T as a result of AT&T's inability to bill for services associated with the recording failure. Net loss shall be defined as the gross revenues to AT&T attributable to the recording failures less the cost of services that BellSouth was unable to bill AT&T and the internal costs AT&T avoided as a result of the recording failure.

- 6.1.1 BellSouth shall include the amount of unbillable AT&T revenue that is attributable to failures to record, within the monthly billing statement.

6.2 **Lost, Damaged, Destroyed Message Data**

- 6.2.1 When AT&T message data are lost, damaged, or destroyed as a result of BellSouth error or omission when BellSouth is performing the billing and/or recording function, and the data cannot be recovered or resupplied in time for the time period during which messages can be billed according to legal limitations, or such other time periods that may be agreed to by the Parties within the limitations of the law, BellSouth shall notify AT&T of the amount of estimated AT&T revenue in accordance with Section 6.3 of this Attachment and BellSouth shall compensate AT&T for the net loss to AT&T.

- 6.2.2 When AT&T message data are lost, damaged, or destroyed as a result of BellSouth error or omission when AT&T is performing the billing and/or recording function, and the data cannot be recovered or resupplied in time for the time period during which messages can be billed according to legal limitations, or such other time periods that may be agreed to by the Parties within the limitations of the law, BellSouth shall notify AT&T of the amount of estimated AT&T revenue in accordance with Section 6.3 and BellSouth shall compensate AT&T for the net loss to AT&T.

- 6.2.3 BellSouth shall notify AT&T in advance of the date of monthly billing statement that shall contain such adjustments. BellSouth shall provide sufficient information to allow AT&T to analyze the language.

6.3 **Recording Quality**

  
FL6/10/97

6.3.1 Material Loss

BellSouth shall review its daily controls to determine if data has been lost. BellSouth shall use the same procedures to determine an AT&T material loss as it uses for itself. The message threshold used by BellSouth to determine a material loss of its own messages will also be used to determine a material loss of AT&T messages. When it is known that there has been a loss, actual message and minute volumes should be reported if possible. Where actual data are not available, a full day shall be estimated for the recording entity as outlined in the paragraph below titled Estimating Volumes. The loss is then determined by subcontracting recorded data from the estimated total day business.

6.3.2 Complete Loss

Estimated message and minute volumes for each loss consisting of an entire/tape or file lost in transit, lost after receipt, degaussed before processing, received blank or unreadable, etc. shall be reported. Also the loss of one or more boxes of operator tickets shall be estimated and reported if applicable.

6.3.3 Estimated Volumes

From message and minute volume reports for the entity experiencing the loss. BellSouth shall secure message/minute counts for the corresponding day of the weeks for two (2) weeks preceding the week following that in which the loss occurred. BellSouth shall apply the appropriate Average Revenue Per Message (ARPM) to the estimated message volume to arrive at the estimated lost revenue.

**Exceptions:**

- A. If the day of loss is not a holiday but one (1) (or more) of the preceding corresponding days is a holiday, use an additional number of weeks in order to procure volumes for two (2) non-holidays.
- B. If the call or usage data lost represents calls or usage on a weekday which is a holiday (except Christmas and Mothers Day), use volumes from the preceding and following Sunday.
- C. If the call or usage data lost represents calls or usage on Mother's Day or Christmas, use volumes from that day in the preceding year (if available).
- D. In the selection of corresponding days for use in developing estimates, consideration shall be given to other conditions which may affect call volumes such as tariff changes, weather and local events (conventions, festivals, major

sporting events, etc.) in which case the use of other days may be more appropriate.

6.4 **Unbillable Compensation**

6.4.1 BellSouth liability for such unbillables shall be limited to instances of error or omission, including but limited to, the acts or omissions of BellSouth employees, agents and contractors, and the failures of BellSouth hardware, software and other BellSouth equipment. BellSouth's liability to AT&T shall be limited to the net loss to AT&T.

6.4.2 The term "unbillable" refers to a message or service that cannot be billed to the correct AT&T customer.

6.4.3 BellSouth shall include Unbillables as a result of Recording Failure, or Lost, Damaged, or Destroyed Data on the monthly billing statement.

7. **DELETED**

8. **Local Account Maintenance**

8.1 When AT&T purchases Local Service from BellSouth, and, as appropriate, when AT&T purchases certain Unbundled Network Elements, BellSouth shall provide AT&T with Local Account Maintenance as described herein. These procedures are in addition to Service Order procedures set forth in Part I and Attachment 4 to the Agreement.

8.2 When notified by a CLEC that an AT&T Customer has switched to CLEC service, BellSouth shall provision the change, and notify AT&T via CONNECT:Direct that the customer has changed to another service provider ("OUTPLOC").

8.3 When notified by AT&T that a customer has changed his/her PIC only from one interexchange carrier to another carrier, BellSouth shall provision the PIC only change and convey the confirmation of the PIC change via the work order completion feed.

8.4 If notified by an interexchange carrier using an '01' PIC order record that an AT&T Customer has changed his/her PIC only, BellSouth will reject the order and notify that interexchange carrier that a CARE PIC record should be sent to the serving CLEC for processing.

9. **Incollect/Outcollect Procedures**

9.1

**Definitions**

Centralized Message Distribution System (CMDS) is the BellCore administered system based in Kansas City, used to exchange Exchange Message Record formatted data.

Exchange Message Record (EMR) is the nationally administered standard format for the exchange of data among Carriers within the industry

Outcollect Message - A message that originates on an AT&T line but bills, using AT&T's rates, to an end user served by another Local Service Provider

Incollect Message - A message that originates on another Local Service Provider Line but bills, using that Local Service Provider's rates, to an end user by AT&T.

ICS - Inter-Company settlements is the revenue associated with charges billed by a company other than the company in whose service area such charges were incurred in Florida.

Non-ICS - Non-inter Company settlements is the revenue associated with charges billed and earned within the same state. (Intra-state)

9.2

**Incollect Services**

AT&T will purchase and bill rated Incollect Messages from BellSouth. BellSouth will notify AT&T of any changes to Subappendix F within thirty (30) days of the effective date of such change. Both AT&T and BellSouth must mutually agree to this change.

9.2.1

**Message Types Subject to the Services**

AT&T will provide the Incollect Services only for the types of messages identified on Subappendix G to this Attachment 7 (collectively, "Messages").

9.2.2

**Pack Failures/Data Retention**

BellSouth shall notify AT&T of any transmission failure within 24 hours. BellSouth shall correct and retransmit to AT&T any such packs within 24 hours. If message packs are retransmitted for any reason, including, but not limited to, a reject of the packs, damage in transit, dataset naming failures, or similar reasons, if caused by BellSouth, then BellSouth shall assume the expense of replacement unless the need for replacement is caused by AT&T's act or omission. BellSouth agrees to retain copies of all message packs transmitted to AT&T for omission. BellSouth agrees to retain copies of all message packs transmitted to AT&T for minimum of forty-five (45) calendar days of the date of original transmission.

  
FL6/10/97



9.2.3 Message Return Policy

BellSouth will receive messages returned from AT&T that cannot be billed and the appropriate standard field and values on the EMR records will be populated.

9.2.4 Purchase of Messages

AT&T will purchase rated messages from BellSouth at the purchase of accounts receivable rates ("PARS rates") set forth in Subappendix H of this Attachment 7 and will be net the billing and collection rates also set forth in Subappendix H. BellSouth shall provide AT&T with a monthly statement for messages BellSouth transmitted to AT&T for purchase (including returned messages transmitted back to BellSouth as unbillable).

The monthly statement provided by BellSouth shall list the following items:

- number of incollect messages purchased
- number of incollect unbillable messages returned
- + message revenue purchased
- + state taxes associated with purchased messages
- + local taxes associated with purchased messages
- unbillable returned message revenue
- state taxes associated with unbillable returned messages
- local taxes associated with unbillable returned messages
- billing charges (net number of incollect messages purchased/  
returned times B&C rate; B&C should not be applicable if  
purchased messages were returned)

---

**TOTAL AMOUNT DUE BELLSOUTH**

BellSouth shall provide AT&T with a monthly intraregion settlement report to support the monthly statement. The monthly statement and settlement report shall reflect messages processed for purchasing from 26th to 25th of each month. The BellSouth shall deliver to AT&T the monthly statement and settlement report on or before the fifteenth calendar day month immediately following the month in which messages were purchased (including returned messages).

BellSouth shall send monthly statement and settlement report to:

AT&T - Charlotte Billing Center  
Settlements Manager  
10101 David Taylor Drive  
Charlotte, NC 28262

  
FL6/10/97

AT&T shall pay BellSouth via check or wire on or before last business day of the billing statement month (e.g. service month = 4/96, billing month = 5/15/96, payment due date = 5/31/96.)

If the Payment Due Date falls on a Saturday or a bank holiday that is observed on a Tuesday, Wednesday, Thursday or Friday, then the Payment Due Date shall be the last non-holiday day preceding such Saturday or holiday. If the Payment Due Date falls on a Sunday or a bank holiday that is observed on a Monday, then the Payment Due Date shall be the first non-holiday following such Sunday or holiday. AT&T shall pay BellSouth a late payment charge calculated based on the lesser of (i) one and one-half percent (1 1/2%) or (ii) the highest interest rate (in decimal value) which may be charged by law for commercial transactions on all payments received after the due date.

9.2.5 **Taxes**

BellSouth shall be solely responsible for calculation of all applicable sales, excise, taxes, and surcharges on the Messages purchased by AT&T to the appropriate jurisdiction. BellSouth will indicate the tax to be billed to the end user customer on the messages sent to AT&T for billing. FET will be calculated by AT&T but will be BellSouth's responsibility to remit. BellSouth shall file all returns for taxes imposed on, or with respect to messages sold by BellSouth. BellSouth agrees to hold AT&T harmless from and against any liability or loss resulting from any tax, charge, interest, additions to tax, surcharges or other charges payable or incurred by AT&T as a result of BellSouth's failure or error in calculating tax as described in this section.

9.3 **Outcollect Services**

BellSouth shall purchase rated Outcollect Messages and provide message collection and distribution on behalf of AT&T for intraLATA collect, calling card and third number billed messages. For Intraregion non-ICS messages, the billing company is responsible for billing these messages. The Messages will be received through CMDS. BellSouth shall forward such Messages at agreed upon intervals to AT&T. AT&T will notify BellSouth of any changes to Subappendix I to this Attachment 7 within thirty (30) days of the effective date of such change. Both AT&T and BellSouth must mutually agree to this change.

9.3.1 **Message Types Subject to the Services**

BellSouth will provide the Services only for the types of messages identified on Subappendix J (collectively, "Messages"). BellSouth will purchase and forward the messages to AT&T subject to the provisions of Section 9.3 preceding.

9.3.2 **Pack Failures/Data Retention**

  
FLS/10/97

AT&T shall notify BellSouth of any transmission failures within 24 hours. AT&T shall correct and retransmit to BellSouth any such packs within 24 hours. If message packs are retransmitted for any reason including but not limited to a reject of the packs, damage in transit, dataset naming failures or similar reasons, if caused by AT&T, then AT&T shall assume the expense of replacement unless the need for replacement is caused by BellSouth or omission. AT&T agrees to retain copies of all message packs transmitted to BellSouth for minimum of forty-five (45) calendar days of the date of original transmission.

9.3.3 **Message Return Policy**

AT&T will receive messages returned from BellSouth that cannot be billed and the appropriate standard field and values on the EMR records will be populated.

9.3.4 **Purchase of Messages**

BellSouth will purchase messages from AT&T at the purchase of accounts receivable rates ("PARS rates") set forth in Subappendix K ("PARS rates") and will be net the billing and collection rates also set forth on Subappendix K to this Attachment. AT&T shall provide BellSouth with a monthly statement for messages AT&T transmitted to BellSouth via CMDS for purchase (including returned messages transmitted back to AT&T via CMDS as unbillable.)

Monthly statement provided by AT&T shall list the following items:

- number of outcollect messages purchased
- number of outcollect unbillable messages returned
- + message revenue purchased
- + state taxes associated with purchased messages
- + local taxes associated with purchased messages
- + federal taxes associated with purchased messages
- unbillable returned messages revenue
- state taxes associated with unbillable returned messages
- local taxes associated with unbillable returned messages
- federal taxes associated with unbillable returned messages
- billing charges (net number of outcollect messages purchased/returned times B&C rate; B&C should not be applicable if purchased messages were returned)

---

**TOTAL AMOUNT DUE AT&T**

AT&T shall provide BellSouth with a monthly intraregion settlement report to support the monthly statement. Monthly statement and settlement report shall

reflect messages processed through the intraregion settlement system from 26th to 25th of each month. AT&T shall deliver to BellSouth the monthly statement and settlement report on or before the fifteenth calendar day of the month immediately following the month in which messages were purchased (including returned messages). AT&T shall send monthly statement and settlement report to:

**[BELLSOUTH TO PROVIDE]**

BellSouth shall pay AT&T via wire or check on or before the last business day of the billing statement month (e.g. service month - 4/96, billing statement date - 5/15/96, payment due date = 5/31/96.)

If the Payment Due Date falls on a Saturday or a bank holiday that is observed on a Tuesday, Wednesday, Thursday, or Friday, then the Payment Due Date shall be the last non-holiday day preceding such Saturday or holiday. If the Payment Due Date falls on a Sunday or a bank holiday that is observed on a Monday, then the Payment Due Date shall be the first non-holiday following such Sunday or holiday.

AT&T shall pay BellSouth a late payment charge calculated based on the lesser of (i) one and one-half percent (1 1/2%) or (ii) the highest interest rate (in decimal value) which may be charged by law for commercial transactions on all payments received after the due date.

**9.3.5 Taxes**

AT&T shall be solely responsible for calculation of all applicable sales, excise, taxes, and surcharges on the Messages purchased by BellSouth to the appropriate jurisdiction. AT&T will indicate the tax to be billed to the end user customer on the message sent to BellSouth for billing. BellSouth will use the tax on the message for customer billing. FET will be calculated by BellSouth but will be AT&T's responsibility to remit. AT&T shall file all returns for taxes imposed on, or with respect to messages sold by AT&T. AT&T agrees to hold BellSouth harmless from and against any liability or loss resulting from any tax, charge, interest, additions to tax, surcharges or other charges payable or incurred by BellSouth as a result of AT&T's failure or error in calculating tax as described in this section of the Agreement.

**9.4 Settlement of Disputed Amounts and Claims/Escalation Procedures**

If either Party disputes any portion of the Amount Due, said Party shall notify the other Party in writing of the nature and basis of the dispute. Either Party

  
FL6/10/97

may file a substantiated claim with the other Party for billing and collection charges and/or billed revenue. If the dispute is not resolved by the Payment Date, the claiming Party shall pay all undisputed amounts, but is not obligated to pay the disputed amount. If a Party has paid an amount which it subsequently chooses to dispute, that Party shall not be authorized or permitted to reduce amount owed on subsequent bills or statements or in any way offset against such owed amounts the amount being claimed. The Party receiving the claim shall have thirty (30) days from the notification date, or other mutually agreed upon period, to process the claim and notify the claiming Party of the claim status. If the claim, in whole or part, is ultimately resolved in favor of the claimant, the claiming Party shall be entitled to refund or a credit. After written notice to the claiming Party that the claim has been sustained, the total amount of the refund or credit, shall be remitted no later than thirty-one (31) calendar days following resolution. Both Parties shall retain such detailed information as may reasonably be required for resolution of the disputed amount during the pendency of the dispute. No claims may be made more than one (1) year after the date of the event that gave rise to the claim.

In the event that any dispute cannot be resolved under this Section 9.4, the Parties shall follow the provisions set forth in Section 16 of the General Terms and Conditions of the Agreement and Attachment 1.

**9.5 Industry Standards**

The provisions set forth in this Section 9 are intended to cover incollect/out collect procedures until industry standards are adopted. If such standards are adopted, and both Parties agree on such standards, the Parties agree to review these procedures and amend these procedures as appropriate.

*MP*

APPENDIX I  
TO  
ATTACHMENT 7 - DELETED

*MD*

FL6/10/97

**APPENDIX II  
TO  
ATTACHMENT 7**

**CUSTOMER USAGE DATA**

**TRANSFER REQUIREMENTS**

*UB*

FL6/10/97 \

## SECTION I: SCOPE

### 1. General

This Appendix addresses the transmission by a BellSouth of AT&T Customer usage to AT&T.

### 2. Usage Summary

Messages will be transmitted, via a direct feed, to AT&T in standard EMR format.

The following is a list of EMR records that AT&T can expect to receive from BellSouth:

Header Record 20-20-01  
Trailer Record 20-20-02  
Detail Records\* 01-01-01, 06, 07, 08, 09, 16, 18, 31, 32, 33, 35, 37, 80, 81, 82, 83  
10-01-01, 06, 07, 08, 09, 16, 18, 31, 32, 35, 37, 80, 81, 82, 83  
Credit Records 03-01-XX  
Rated Credits 41-01-XX  
Cancel Records 51-01-XX 58-01-XX (Where the Record Being Cancelled is Unrated.)  
Correction Records 71-01-XX

\*Category 01 is utilized for Rated Messages; Category 10 is utilized for Unrated Messages

In addition, BellSouth shall provide a 42-50-01 Miscellaneous Charge record to support the Special Features Star Services (see Subappendix F for specific details) if these features are part of BellSouth's offering.

For detailed information regarding EMR, refer to the current version of the BellCore Practice BR010-200-010 Appendix.

### 3. Appendix Content

This Appendix describes baseline requirements for the transfer of BellSouth recorded, unrated usage to AT&T. Testing requirements and the reports needed to ensure data integrity are also included. Additional requirements and implementation details may be identified for conditions unique to



BellSouth. Modifications and/or exceptions to this Appendix must be negotiated and mutually agreed upon by BellSouth and AT&T

**SECTION II: RECORDED USAGE TO BE TRANSMITTED TO AT&T**

1 **General**

This section addresses the types of usage to be transmitted by BellSouth to AT&T.

2. **Usage To Be Transferred To AT&T**

2.1 **AT&T Usage To Be Transferred**

The following messages recorded by BellSouth are to be transmitted to AT&T. BellSouth recorded usage includes all usage by AT&T Customers.

**NOTE:** Rated incollect messages should be transmitted via the direct feed and can be intermingled with the unrated messages. No special packing is needed.

2.1.1 For the period beginning upon the execution of this Agreement through November 15, 1996, the Parties agree that if any of the above mentioned messages cannot be rated and/or billed by AT&T, BellSouth will work diligently and in good faith with AT&T to determine the cause of the problem and will work to expeditiously resolve the defect. Upon the execution of this Agreement, BellSouth will provide AT&T with a contact name and number for the resolution of any problems that may arise under this subsection. The Parties further agree that if the number of problems that occur are de minimus, the process described in this subsection may be extended for the time period agreed to by the Parties. BellSouth to provide MIC manager name and number.

2.2 File transfer specifications are included within Section III of this Appendix II.

3. **AT&T Usage**

For all Recorded Usage Data provided by BellSouth to AT&T, such Recorded Usage Data in a local resale environment shall include all intraLATA toll and local usage originating from AT&T customers or billed to AT&T. BellSouth will provide AT&T with unrated EMR records associated with all intraLATA toll and local usage which they record on AT&T's behalf. Any Category, Group and/or Record types approved in the future for BellSouth will be included if they fall within the definition of local service resale. AT&T shall be given notification of

*WJ*

implementation of a new type within the negotiated timeframes. NOTE:  
BellSouth messages will be packed using the packing criteria outlined in  
Section III. 4.8 of this Appendix. It is important to note that all BellSouth  
messages will be packed together (intermingled) based on the appropriate  
AT&T Send To/Bill To RAO combination. Specific categories, groups, and  
record types will not be packed separately.

### SECTION III: BELLSOUTH TO AT&T USAGE FEED

1. General

This section contains the information required for BellSouth to transmit to AT&T the usage defined in this Appendix, Section II. This section specifically addresses the dataset requirements and processing.

2. Detailed EMR Record Edits

AT&T will perform detailed record edits on the unrated and rated messages upon receipt from BellSouth. See Appendix II, Section II, Paragraph 2.1.1.

3. Duplicate Record Checks

AT&T will perform record checks on the unrated and rated messages to validate that duplicate messages are not sent by BellSouth to AT&T.

4. BellSouth to AT&T Usage Feed

4.1 DELETED

4.2 Physical Characteristics

Data transported to AT&T on tape or cartridge via a courier will have the physical characteristics indicated in Subappendix A. AT&T's intent is for variable block format (2,476 bytes) with a LRECL of 2472.

4.3 Data Delivery Schedules

Data will be delivered to AT&T by BellSouth daily (Monday through Friday) unless otherwise negotiated. AT&T and/or BellSouth Data Center holidays are excluded. BellSouth and AT&T will exchange schedules of designated Data Center holidays.

4.4 Resending Data

AT&T will notify BellSouth of resend requirements if a pack or entire dataset must be replaced due to pack rejection, damage in transit, dataset name failure, etc.

*LPD*

4.5 **Pack Rejection**

Critical edit failure on the Pack Header or Pack Trailer records will result in pack rejection (e.g., detail record count not equal to grand total included in the pack trailer). Notification of pack rejection will be made by AT&T within one (1) business day of processing. Rejected packs will be corrected by BellSouth and retransmitted to AT&T by BellSouth.

4.6 **Held Packs And Messages**

AT&T and BellSouth will track pack number to control input based upon invoice sequencing criteria. BellSouth will be notified of sequence failures identified by AT&T and resend procedures are to be invoked.

4.7 **Data Content Requirements**

EMR is the format to be used for usage data provided to AT&T.

4.8 **RAO Packing Requirements**

A pack shall contain a minimum of one message record or a maximum of 9,999 message records plus a pack header record and a pack trailer record. A file transmission contains a maximum of 99 packs. A dataset shall contain a minimum of one pack. BellSouth will provide AT&T one dataset per sending location, with the agreed upon RAO/OCN populated in the Header and Trailer records.

Within the Header and Trailer records, the FROM RAO identifies the location that will be sending usage to AT&T. BellSouth will populate the FROM RAO field with the unique numeric value identifying the location that is sending the data to AT&T. BellSouth will populate the Send To/Bill To RAO fields with the appropriate AT&T RAO values. Also, Pack Header and Trailer will have the OCN appropriately populated.

The FROM RAO, OCN, and Remote Identifiers will be used by AT&T to control invoice sequencing and each will have its own invoice controls. See previous notes regarding Unbillables—accepting BST's Contact Number and BST Accepts AT&T's 2.1.1. terms.

The file's Record Format (RECFM) will be Variable Block (VB) Size 2,476 and the Logical Record Length (LRECL) will be 2,472 bytes.

AT&T has no special sort requirements for the packs sent by BellSouth.

#### 4.9 Dataset Naming Convention

BellSouth will transmit the usage to AT&T using the following dataset naming conventions. The dataset name (DSN) will be partitioned into five nodes, separated by periods as follows:

NODE 1.BB3PXNM\*  
NODE 2.IBMUP  
NODE 3 (To be determined during negotiations)  
NODE 4.USAGE

NODE 5.GNNMV\* (Generational Dataset to be incremented by sender).  
\*The italicized "M" represents numeric fields determined during negotiations.

#### 4.10 Control Reports

AT&T accepts input data provided by BellSouth in EMR format in accordance with the requirements and specifications detailed in this section of the attachment. In order to ensure the overall integrity of the usage being transmitted from BellSouth to AT&T, data transfer control reports will be required. These reports shall be provided by AT&T to BellSouth on a daily or otherwise negotiated basis and reflect the results of the processing for each pack transmitted by BellSouth.

#### 4.11 Message Validation Reports

AT&T will provide the following three (3) daily (or otherwise negotiated) Message Validation reports to the designated BellSouth System Control Coordinator. These reports will be provided for all data received within BellSouth Local Resale Feed and will be transmitted Monday through Friday whether or not there have been any files transmitted.

##### 4.11.1 Message Validation Pack Reject Report (A7287)

This report provides information on packs rejected by AT&T. It lists the header and trailer record of each rejected pack and indicates the error codes and the associated error message which explains why the pack was rejected.

An example of the report and a list of Valid Error Codes and associated error messages are provided in Subappendix B hereto.

##### 4.11.2 Message Validation Pack Accepted Report (A7288)

This report provides vital statistics and control totals by Record ID, Type of Service, Message Counts and Record Counts, for all valid, rejected and



dropped messages. The information is provided in the following report formats and control levels:

1. BellSouth Total Messages
2. BellSouth Total Records
3. RAO Total Messages
4. RAO Total Records
5. Pack Total (Record Counts and Message Counts)

The first four report formats include percentages that indicate the relationship of the daily input volume by Record ID and Type of Record to the total input volume provided by an RAO and BellSouth.

An example of the report is provided in Subappendix C hereto.

#### 4.11.3 **Message Validation Detail Error Report (A7289)**

An EMR detailed error report is generated for each pack/invoice that is received and processed by AT&T. The report lists, in vertical format, the complete 175 byte EMR record that has failed to pass the initial edit criteria. It prints this detailed information only for the first five EMR records that share a common error condition. The error condition is flagged on the report by one of two possible error codes preceding the field value. The error codes are:

(C) DENOTES CRITICAL ERRORS

(I) DENOTES INFORMATION ERRORS

The last two pages of the report for a given pack/invoice provide the following control totals:

Total Errors for each Field

Total Records Received

Total Records Dropped

Total Records Rejected to MIU

Pack Reject Rate

Total Default Count (represents the number of Files on all of the input records that had to be programmatically altered to meet the EMR standards and specifications.)

If the entire pack/invoice has been rejected because of a Critical Error Rate greater than 0.5%, the last page of the report will display such a statement enclosed in asterisks.

An example of the report is provided in Subappendix D hereto.

4.11.4 Control Reports - Distribution

Since BellSouth is not receiving control reports, dataset names will be established during detailed negotiations.





## SECTION IV: AT&T PROCESSING REQUIREMENTS

### General

This section contains requirements for AT&T processing of Recorded Usage Data that has been transmitted to AT&T for billing.

### 2. AT&T Rating Process

#### 2.1 Message Rating

AT&T will rate any individual messages (as defined in Section II of this Appendix), that have not already been rated by BellSouth, prior to transmitting the usage to a billing environment within AT&T.

#### 2.2 Application Of Taxes/Fees/Surcharges

AT&T will apply taxes, fees and surcharges as appropriate for the individual messages and/or customer accounts. The application of all taxes, fees and surcharges will be applied on all intraLATA local and toll usage received from BellSouth.

#### 2.3 Duplicate Messages

AT&T has existing duplicate checks as part of their message processing or billing functions. AT&T will perform these checks on the rated/unrated messages sent pursuant to BellSouth duplicate message disposition procedures and reports will be identified by AT&T during negotiations.

#### 2.4 Record Edits

##### 2.4.1 AT&T Record Edits

See Appendix II, Section II, Paragraph 2.1.1. AT&T will perform detailed record edits on the rated and unrated messages prior to transmitting them to the billing environment.

##### 2.4.2 BellSouth Record Edits

If BellSouth has existing detailed record edits for rated and unrated messages, BellSouth is to perform these edits.

See Appendix II, Section II, Paragraph 2.1.1

2.4.3 AT&T To BellSouth Message Returns

See Appendix II, Section II, Paragraph 2.1.1. (At the discretion of AT&T messages that have been sent to AT&T by BellSouth that cannot be guided to an AT&T billed account or error in processing will be returned to BellSouth with the appropriate negotiated return codes as provided in this Appendix, Section II, 2.1 and Section II, 2.1.1.)

2.4.4 Cancel/Correction Records

AT&T, upon receipt of cancel/correction records, will perform their current matching functionality to identify the original message to be canceled/corrected. (Processing will be dependent upon individual negotiations.)

*LB*

## SECTION V: TEST PLANS AND ACTIVITIES

### General

This section defines BellSouth and AT&T activities which are required prior to implementation. The tests and activities described are necessary to ensure a smooth, accurate and well-programmed conversion. Specific test dates will be identified through the negotiations process.

### 2. Interface Testing

The purpose of this test is to ensure that the usage described in Section II of this Appendix preceding can be sent by BellSouth to AT&T and can be accepted and processed by AT&T. BellSouth will provide a test file to AT&T's designated Regional Processing Center (RPC) in the format that will be used for live day-to-day processing. The file will contain that production Data Usage that AT&T and BST agree upon. The format of the file will conform to the requirements shown in Section III. AT&T will review the file and verify that it conforms to its data center requirements. AT&T will notify BellSouth in writing whether the format is acceptable. AT&T will also provide BellSouth with the agreed-upon control reports as part of this test.

### 3. Operational Test

The purpose of this test is to ensure that volumes of usage in consecutive sequence can be extracted, distributed, and processed by BellSouth and AT&T.

BellSouth is required to provide AT&T with BellSouth recorded, unrated usage (as defined in Section II of this Appendix) for a minimum of five (5) consecutive days. AT&T will provide BellSouth with the message validation reports associated with test usage.

AT&T will rate and process the unrated intraLATA toll and local usage. AT&T will process this data to test bills. AT&T may request that the test usage contain specific usage volumes and characteristics to ensure a complete test. Specific usage volumes and characteristics will be discussed during detailed negotiations.

### 4. Test File



FL6/10/97

Test data should be transported via CONNECT Direct whenever possible. In the event that courier service must be used to transport test media, the physical tape characteristics to be used are described in Subappendix A hereto.

AT&T personnel will review the impact of the change on the entire control structure as described in Appendix II Section 5, Post Conversion Test Plan herein. AT&T will negotiate any perceived problems with BellSouth and will arrange to have the data tested utilizing the modified software.

If it is necessary for BellSouth to request changes in the schedule, content or format of usage data transmitted to AT&T, BellSouth will notify AT&T

3.1 **AT&T Requested Changes**

If it is necessary for AT&T to request changes in the schedule, content, or format of the usage data transmitted from BellSouth, AT&T will notify BellSouth.

When the negotiated changes are to be implemented, AT&T and/or BellSouth will arrange for testing of the modified data as described in Appendix II, Section 5, Post Conversion Test Plan.

4. **AT&T Software Changes**

When AT&T plans to introduce any software changes which may impact the format or content structure of the usage data transmitted from BellSouth, AT&T will notify the designated BellSouth personnel, no less than one hundred twenty (120) calendar days before such changes are implemented.

The AT&T contact will communicate the projected changes to the appropriate groups in BellSouth so that potential impacts on BellSouth processing can be determined.

AT&T will negotiate any perceived problems with BellSouth and will arrange to have the data tested utilizing the modified software.

Altering the one hundred twenty (120) day window for introducing software changes can be negotiated by both companies, dependent upon the scope and impact of the change.

5. **Post-Conversion Test Plan**

The test plan described below is designed to encompass all types of changes to the usage data transferred by BellSouth to AT&T and the methods of transmission for that data.



FL6/10/97

## 5.1 BellSouth System Change Description

For a BellSouth system change, BellSouth shall provide AT&T with an overall description of the change, stating the objective and a brief explanation of the reasons for the change.

During the initial negotiations regarding the change, BellSouth shall provide a list of the specific records and/or systems impacted by the change to designated AT&T personnel.

Finally, BellSouth shall also provide AT&T a detailed description of the changes to be implemented. It shall include sufficient detail for designated AT&T personnel to analyze and estimate the effects of the changes and to design tests to verify the accuracy of the implementation.

## 5.2 Change Negotiations

AT&T shall be notified in writing of all proposed negotiations initiated by BellSouth. In turn, AT&T will notify BellSouth of proposed change negotiations initiated by AT&T.

After formal notification of planned changes, whether originated by BellSouth or AT&T, designated AT&T personnel will schedule negotiation meetings as required with designated BellSouth personnel. The first meeting should produce the overall change description (if not previously furnished) and the list of records and/or systems affected.

In subsequent meetings, BellSouth shall provide the detailed description of changes to be implemented. After reviewing the described changes, designated AT&T personnel will negotiate a detailed test procedure with BellSouth.

## 5.3 Control Change Analysis

Based on the detailed description of the changes provided by BellSouth, and the review of the projected changes by AT&T, designated AT&T personnel will:

- 5.3.1 Determine the impact of the changes on the overall structure.
- 5.3.2 Determine whether any single change has a potential control impact (i.e., high error rate on individual records that might result in pack rejection);
- 5.3.3 Determine whether any controls might be adversely affected; and

- 5.3.4 Arrange for appropriate control structure changes to meet any of the above conditions.
- 5.4 **Verification Of Changes**
  - 5.4.1 Based on the detailed description of changes furnished by BellSouth, designated AT&T personnel will:
    - 5.4.1.1 Determine the type of change(s) to be implemented.
    - 5.4.1.2 Develop a comprehensive test plan.
    - 5.4.1.3 Negotiate scheduling and transfer of modified data with BellSouth.
    - 5.4.1.4 Negotiate testing of modified data with the appropriate AT&T RPC.
    - 5.4.1.5 Negotiate processing of verified data through the AT&T billing system with the RPC.
    - 5.4.1.6 Arrange for review and verification of testing with appropriate AT&T groups.
    - 5.4.1.7 Arrange for review of modified controls, if applicable.
  - 5.5 **Introduction of Changes**
    - 5.5.1 When all the testing requirements have been met and the results reviewed and accepted, designated AT&T personnel will:
      - 5.5.1.1 Negotiate an implementation schedule.
      - 5.5.1.2 Verify the existence of a contingency plan with the appropriate AT&T personnel.
      - 5.5.1.3 Arrange for the follow-up review of changes with appropriate AT&T personnel.
      - 5.5.1.4 Arrange for appropriate changes in control program, if applicable.
      - 5.5.1.5 Arrange for long-term functional review of impact of changes on the AT&T billing system, i.e., accuracy, timeliness, and completeness.



SECTION VII: SUBAPPENDICES

**SUMMARY OF SUBAPPENDICES**

**Subappendix A**

Physical Characteristics Of Data Tapes/  
Cartridges

**Subappendix B - DELETED**

**Subappendix C**

Message Validation Pack Accepted Report (A7288)

**Subappendix D**

Message Validation EMR Detail Error Report (A7289)

**Subappendix E**

Special Features Star Services

**Subappendix F**

Carrier from which AT&T will buy messages

**Subappendix G**

Types of Messages

**Subappendix H**

*UP*



Subappendix I

Subappendix J

Subappendix K

MB

## SUBAPPENDIX A

### PHYSICAL CHARACTERISTICS OF DATA TAPES/CARTRIDGES

Data transported to AT&T by the BellSouth, or to the BellSouth by AT&T on tape or cartridge via a courier will have the following physical characteristics:

Tape:	9-track, 6250 (or 1600) BPI (Bytes per inch)
Cartridge:	38,000 BPI (Bytes per inch)
LRECL:	2,472 Bytes
Parity:	Odd
Character Set:	Extended Binary Coded Decimal Interchange Code (EBCDIC)
External labels:	Exchange Carrier Name, Dataset Name (DSN) and volume serial number
Internal labels:	IBM Industry OS labels will be used. They consist of a single volume label and two sets of header and trailer labels.
One file per sending location with variable length records	104 bytes EMR compacted format plus modules as applicable.



FL6/10/97

SUBAPPENDIX B

DELETED

*leB*

FL6/10/97

**SUBAPPENDIX C**

**MESSAGE VALIDATION PACK REJECT REPORT (A7287)**

MM/DD/YY 11/11 MM SS

RETEL CODE: 01R 00300

```

COMPANY  XXXXXXXXXXXXXXXXXXXXXXXXXXXXXXXXXXXXXXXXXXXXXXXXXXXXXXXXXXXXXXXX  REMOTE ID  9999X  FROM BSID 999
HEADER  RECORD ID  DATE CREATED  INVOICE NUMBER  BELL CO ID  BELL RAO  IX CARRIER  IND CO ID
          9000000  90-90-90  99  999  999  999  9999
TOTAL REC.
TRAILER RECORD ID  DATE CREATED  INVOICE NUMBER  BELL CO ID  BELL RAO  IX CARRIER  IND CO ID
COUNT           9000000  90-90-90  99  999  999  999  9999
90,999
    
```

**ERRORS ERROR CODE ERROR MESSAGE**

```

EC99 9
XXXXXXXXXXXXXXXXXXXXXXXXXXXXXXXXXXXXXXXXXXXXXXXXXXXXXXXXXXXXXXXXXXXXXXXXX
XXXXXXXXXXXXXXXXXXXXXXXXXXXXXXXXXXXXXXXXXXXXXXXXXXXXXXXXXXXXXXXXXXXXXXXXX
    
```

**SUBAPPENDIX C (CONT'D)**  
**MESSAGE VALIDATION PACK REJECT REPORT (A7287)**

<b>ERROR CODE</b>	<b>ERROR MESSAGES</b>
EC01 2	First record after trailer is not a Pack Header.
EC03 2	From RAO is not numeric.
EC04 3	Invoice number on header invalid.
EC04 5	Company ID not numeric.
EC04 6	Independent company ID is not numeric.
EC04 7	Header Record ID is invalid.
EC04 8	Trailer Record ID is invalid.
EC04 9	Trailer Record count invalid.
EC05 0	Duplicate pack.
EC05 1	Old Pack.
EC05 2	RAO not found on table.
EC07 3	Error rate greater than invoice file threshold for RAO invoice number.
EC12 0	Remote ID in Dataset is not valid.
EC20 0	No detail records in pack.
EC13 0	Invalid status on Pack Header.
EC27 0	Pack exceeds limit of 9,999 detail records.
EC40 9	Pack Header record is missing.
EC41 0	Trailer record is missing.
EC42 0	Trailer message volume is not equal to accumulated message volume.
EC44 0	Header/Trailer date is invalid.
EC45 0	From RAO on Trailer Record is not equal to the from RAO on Header Record.
EC48 0	Invoice number on Trailer Record is not equal to the invoice number on the Header Record.

ERS

SUBAPPENDIX D - MESSAGE VALIDATION PACK ACCEPTED REPORT (A7288)

MM/DD/YY-----HH:MM:SS

RETEN CODE: 01R-00300

-----  
 COMPANY   XXX   FROM RAO   INVOICE NO   DATE CREATED  
 TOTAL RECORDS RECEIVED  
 -----999-----99-----MM/DD/YY-----  
 -----ZZ ZZ9

RECORD ID	MESSAGE COUNTS				RECORD COUNTS		
	TYPE OF RECORD	VALID	REJECTED	DROPPED	TOTAL	VALID	REJECTED
010102	OUTWATS (NON-SMDR)	ZZ ZZ9	ZZ ZZ9	ZZ ZZ9	ZZ ZZ9	ZZ ZZ9	ZZ ZZ9
		ZZ ZZ9	ZZ ZZ9				
010103	OUTWATS (SMDR)	ZZ ZZ9	ZZ ZZ9	ZZ ZZ9	ZZ ZZ9	ZZ ZZ9	ZZ ZZ9
		ZZ ZZ9	ZZ ZZ9				
010104	800 SERVICE	ZZ ZZ9	ZZ ZZ9	ZZ ZZ9	ZZ ZZ9	ZZ ZZ9	ZZ ZZ9
		ZZ ZZ9	ZZ ZZ9				
	TOTAL WATS/800						
010101	MTS				ZZ ZZ9	ZZ ZZ9	ZZ ZZ9
		ZZ ZZ9	ZZ ZZ9	ZZ ZZ9	ZZ ZZ9		
010106	NON-DIAL CONFER BRIDGE	ZZ ZZ9	ZZ ZZ9	ZZ ZZ9	ZZ ZZ9	ZZ ZZ9	ZZ ZZ9
		ZZ ZZ9	ZZ ZZ9				
010107	NON-DIAL CONFER LEG RECORD	ZZ ZZ9	ZZ ZZ9	ZZ ZZ9	ZZ ZZ9	ZZ ZZ9	ZZ ZZ9
		ZZ ZZ9	ZZ ZZ9				
010108	DIAL CONFERENCE BRIDGE	ZZ ZZ9	ZZ ZZ9	ZZ ZZ9	ZZ ZZ9	ZZ ZZ9	ZZ ZZ9
		ZZ ZZ9	ZZ ZZ9				

213

010111		ALLIANCE (AGTC)	ZZ.ZZ9	ZZ.ZZ9	ZZ.ZZ9	ZZ.ZZ9	ZZ.ZZ9	ZZ.ZZ9	ZZ.ZZ9
	ZZ.ZZ9	ZZ.ZZ9							
010116		DIAL-IT SERVICE	ZZ.ZZ9	ZZ.ZZ9	ZZ.ZZ9	ZZ.ZZ9	ZZ.ZZ9	ZZ.ZZ9	ZZ.ZZ9
	ZZ.ZZ9	ZZ.ZZ9							
010132		DIRECTORY ASSISTANCE	ZZ.ZZ9	ZZ.ZZ9	ZZ.ZZ9	ZZ.ZZ9	ZZ.ZZ9	ZZ.ZZ9	ZZ.ZZ9
	ZZ.ZZ9	ZZ.ZZ9	ZZ.ZZ9						
010180		MARINE/AIRCRAFT	ZZ.ZZ9	ZZ.ZZ9	ZZ.ZZ9	ZZ.ZZ9	ZZ.ZZ9	ZZ.ZZ9	ZZ.ZZ9
	ZZ.ZZ9	ZZ.ZZ9							
010181		RADIO LINK	ZZ.ZZ9	ZZ.ZZ9	ZZ.ZZ9	ZZ.ZZ9	ZZ.ZZ9	ZZ.ZZ9	ZZ.ZZ9
	ZZ.ZZ9	ZZ.ZZ9							
010182		MARINE NON-DIAL CONFER BRIDGE	ZZ.ZZ9	ZZ.ZZ9	ZZ.ZZ9	ZZ.ZZ9	ZZ.ZZ9	ZZ.ZZ9	ZZ.ZZ9
	ZZ.ZZ9	ZZ.ZZ9	ZZ.ZZ9						
010183		MARINE NON-DIAL CONFER LEG REC.	ZZ.ZZ9	ZZ.ZZ9	ZZ.ZZ9	ZZ.ZZ9	ZZ.ZZ9	ZZ.ZZ9	ZZ.ZZ9
	ZZ.ZZ9	ZZ.ZZ9	ZZ.ZZ9						
0101XX		OTHER MTS RECORDS	ZZ.ZZ9	ZZ.ZZ9	ZZ.ZZ9	ZZ.ZZ9	ZZ.ZZ9	ZZ.ZZ9	ZZ.ZZ9
	ZZ.ZZ9	ZZ.ZZ9							
TOTAL NORTH AMERICAN MTS									

010201		IOTC/IDDD MTS	ZZ.ZZ9	ZZ.ZZ9	ZZ.ZZ9	ZZ.ZZ9	ZZ.ZZ9	ZZ.ZZ9	ZZ.ZZ9
	ZZ.ZZ9	ZZ.ZZ9							
0102XX		IOTC/IDDD OTHERS	ZZ.ZZ9	ZZ.ZZ9	ZZ.ZZ9	ZZ.ZZ9	ZZ.ZZ9	ZZ.ZZ9	ZZ.ZZ9
	ZZ.ZZ9	ZZ.ZZ9							
010301		IOTC BFC MTS	ZZ.ZZ9	ZZ.ZZ9	ZZ.ZZ9	ZZ.ZZ9	ZZ.ZZ9	ZZ.ZZ9	ZZ.ZZ9
	ZZ.ZZ9	ZZ.ZZ9							
0103XX		IOTC BFC OTHERS	ZZ.ZZ9	ZZ.ZZ9	ZZ.ZZ9	ZZ.ZZ9	ZZ.ZZ9	ZZ.ZZ9	ZZ.ZZ9
	ZZ.ZZ9	ZZ.ZZ9							
010401		IOC MTS				ZZ.ZZ9	ZZ.ZZ9	ZZ.ZZ9	ZZ.ZZ9
	ZZ.ZZ9	ZZ.ZZ9	ZZ.ZZ9	ZZ.ZZ9	ZZ.ZZ9				
0104XX		IOC OTHERS	ZZ.ZZ9	ZZ.ZZ9	ZZ.ZZ9	ZZ.ZZ9	ZZ.ZZ9	ZZ.ZZ9	ZZ.ZZ9
	ZZ.ZZ9	ZZ.ZZ9							
010501		IOC MTS				ZZ.ZZ9	ZZ.ZZ9	ZZ.ZZ9	ZZ.ZZ9
	ZZ.ZZ9	ZZ.ZZ9	ZZ.ZZ9	ZZ.ZZ9	ZZ.ZZ9				
0105XX		IOC OTHERS	ZZ.ZZ9	ZZ.ZZ9	ZZ.ZZ9	ZZ.ZZ9	ZZ.ZZ9	ZZ.ZZ9	ZZ.ZZ9
	ZZ.ZZ9	ZZ.ZZ9							

52

TOTAL OVERSEAS MTS

015002		OUTWATS LINE SUMMARY	ZZ ZZ9	ZZ ZZ9	ZZ ZZ9	ZZ ZZ9	ZZ ZZ9	ZZ ZZ9
	ZZ ZZ9	ZZ ZZ9	ZZ ZZ9					
015004		800 LINE SUMMARY	ZZ ZZ9	ZZ ZZ9	ZZ ZZ9	ZZ ZZ9	ZZ ZZ9	ZZ ZZ9
	ZZ ZZ9	ZZ ZZ9						
015032		DIR. ASSISTANCE LINE SUMMARY	ZZ ZZ9	ZZ ZZ9	ZZ ZZ9	ZZ ZZ9	ZZ ZZ9	ZZ ZZ9
	ZZ ZZ9	ZZ ZZ9	ZZ ZZ9					
TOTAL OVERSEAS MTS								
03XXXX		CREDIT REQUESTS	ZZ ZZ9	ZZ ZZ9	ZZ ZZ9	ZZ ZZ9	ZZ ZZ9	ZZ ZZ9
	ZZ ZZ9	ZZ ZZ9						
51/52		CANCEL REQUESTS	ZZ ZZ9	ZZ ZZ9	ZZ ZZ9	ZZ ZZ9	ZZ ZZ9	ZZ ZZ9
	ZZ ZZ9	ZZ ZZ9						
71/72		CORRECTION REQUESTS	ZZ ZZ9	ZZ ZZ9	ZZ ZZ9	ZZ ZZ9	ZZ ZZ9	ZZ ZZ9
	ZZ ZZ9	ZZ ZZ9	ZZ ZZ9					
INVALID RECORD IDENTIFICATION			ZZ ZZ9			ZZ ZZ9	ZZ ZZ9	ZZ ZZ9
	ZZ ZZ9							
PACK TOTALS			ZZ ZZ9	ZZ ZZ9	ZZ ZZ9	ZZ ZZ9	ZZ ZZ9	ZZ ZZ9

53



**SUBAPPENDIX E**

**PAPER COPY OF THIS REPORT TO BE PROVIDED**

*ed*

**SUBAPPENDIX E  
SPECIAL FEATURES STAR SERVICES**

The following are STAR Services supported by these Local Resale requirements to date. When identified, additional services can be negotiated to be included in this Resale offer.

- 1) Busy Redial/ Last Number Redial ..... This feature allows a customer to redial a number when a Busy signal is encountered.
- 2) Call Return/Missed Call Dialing ..... This feature allows a customer to automatically return the most recent incoming call, even if it is not answered.
- 3) Call Trace ..... This feature allows the tracing of nuisance calls.
- 4) 3-Way Calling ..... This feature allows for three (3) Parties to communicate on one line.
- 5) Automatic Redial ..... This feature allows a customer to automatically redial the last number dialed.

To provide for the transfer and billing of these features the following requirements apply.

For all "per use" STAR Features the 'Miscellaneous Charge Line Summary Non-Detail Charge' 425001 record should be used and be populated as follows:

CONNECT TIME MISCELLANEOUS TEXT CODE	POSITIONS 55 - 60 POSITIONS 168 - 172	MUST BE POPULATED
MISCELLANEOUS *TEXT CODE	POSITIONS 168 - 172	1) BUSY REDIAL/LAST NUMBER REDIAL POPULATE WITH '00001'
MISCELLANEOUS TEXT CODE	POSITIONS 168 - 172	2) CALL RETURN/LAST NUMBER REDIAL POPULATE WITH '00002'
MISCELLANEOUS TEXT CODE	POSITIONS 168 - 172	3) CALL TRACE POPULATE WITH '00003'
MISCELLANEOUS TEXT CODE	POSITIONS 168-172	4) 3-WAY CALLING POPULATE WITH '00004'
MISCELLANEOUS TEXT CODE	POSITIONS 168-172	5) AUTOMATIC REDIAL POPULATE WITH '00005'

NOTE: For fields not specifically defined, the standard EMR format for a 425001 record should be used

**SUBAPPENDIX F**

**Subappendix F sets forth the Carrier from which AT&T will buy messages:**

**BellSouth**

LB

**SUBAPPENDIX G**

**Subappendix G sets forth the types of messages for which AT&T will provide the Services.**

**INTRALATA LOCAL AND TOLL COLLECT**

**INTRALATA LOCAL AND TOLL BILLED TO THIRD NUMBER**

**INTRALATA LOCAL AND TOLL CALLING CARD**

*Handwritten mark*

**SUBAPPENDIX H**

**PURCHASE OF ACCOUNTS RECEIVABLE RATE: 100%**

**BILLING AND COLLECTIONS RATES: .05 per message**

JB

**SUBAPPENDIX I**

**Subappendix I sets forth the Carrier from which BellSouth will buy messages.**

**AT&T**

*MB*

**SUBAPPENDIX J**

**MESSAGES**

**Subappendix J sets forth the types of messages for which BellSouth will provide the Services.**

**LOCAL INTRAREGION AND TOLL COLLECT**

**LOCAL INTRAREGION AND TOLL BILLED TO THIRD NUMBER**

**LOCAL INTRAREGION AND TOLL CALLING CARD**

*JEB*

**SUBAPPENDIX K**

**RATES**

**PURCHASE OF ACCOUNTS RECEIVABLE RATE: 100%**

**BILLING AND COLLECTIONS RATES: .05 per message**

*MS*



TABLE OF CONTENTS

	<u>PAGE</u>
LOCAL NUMBER PORTABILITY	
1. BellSouth Provision of Local Number Portability.....	1
2. Interim Number Portability (INP).....	1
3. Permanent Number Portability (PNP).....	3
4. Requirements for INP and PNP.....	3



## LOCAL NUMBER PORTABILITY

### BellSouth Provision of Local Number Portability

BellSouth shall provide number portability in accordance with requirements of the Act. Interim Number Portability (INP) will be provided by BellSouth to AT&T, immediately upon the Effective Date of this Agreement. INP will be provided with minimum impairment of functionality, quality, reliability and convenience to subscribers of AT&T services. BellSouth will provide PNP as soon as it is technically feasible, in conformance with FCC rules, the Act, and the Florida Public Service Commission.

#### 1.A AT&T Provision of Local Number Portability

Upon request by BellSouth, AT&T shall provide number portability in accordance with the requirements of the Act and the Florida Public Service Commission. BellSouth and AT&T shall negotiate in good faith AT&T's provisions of INP to BellSouth consistent with BellSouth's actual requirements and AT&T's technical capabilities.

### 2. Interim Number Portability (INP)

INP shall be provided by Remote Call Forwarding ("RCF"), Route Indexing, or Local Exchange Routing Guide (LERG) reassignment. In addition to providing RCF, BellSouth agrees to provide Route Indexing and LERG reassignment in every local service office. Pricing for INP alternatives, if any, shall be as set forth in Part IV of the General Terms and Conditions of this Agreement. AT&T shall specify on a per telephone number basis which method is to be employed and BellSouth shall provide such method to the extent technically feasible.

#### 2.1 Remote Call Forwarding

Remote Call Forwarding (RCF) is an existing switch-based BellSouth service that may be used to provide subscribers with limited service-provider LNP by redirecting calls within the telephone network. When RCF is used to provide LNP, calls to the ported number will first route to the BellSouth switch to which the ported number was previously assigned. The BellSouth switch will then forward the call to a number with an NXX associated with the AT&T operated switch to which the number is ported. AT&T shall be required to order, additional paths to handle multiple simultaneous calls to the same ported telephone number.

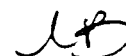

FL6/10/97

2.2 **Route Indexing**

Route Indexing (RI) may take two forms: Route Index-Portability Hub (RI-PH) or Directory Number-Route Index (DN-RI).

2.2.1 RI-PH will route a dialed call to the BellSouth switch associated with the NXX of the dialed number. The BellSouth switch shall then insert a prefix onto the dialed number which identifies how the call is to be routed to AT&T as the local service provider. The prefixed dialed number is transmitted to the BellSouth tandem switch to which AT&T is connected. The prefix is removed by the operation of the tandem switch and the dialed number is routed to AT&T's switch so the routing of the call can be completed by AT&T.

2.2.2 DN-RI is a form of RI-PH that requires direct trunking between the BellSouth switch to which the ported number was originally assigned and the AT&T switch to which the number has been ported. The BellSouth switch shall send the originally dialed number to the AT&T switch without a prefix.

2.2.3 BellSouth shall provide RI-PH or DN-RI on an individual telephone number basis, as AT&T designates. Where technically feasible, AT&T may designate both methods so that calls to ported numbers are first directed to the AT&T switch over direct trunks but may overflow to tandem trunks if all trunks in the direct group are occupied.

2.2.4 For both RI-PH and DN-RI the trunks used may, at AT&T's option, and where technically feasible, be the same as those used for exchange of other local traffic and intraLATA toll traffic with BellSouth. At AT&T's option, the trunks shall employ SS7 or in band signaling.

2.3 **LERG Reassignment**

Portability for an entire NXX: Local Exchange Routing Guide (LERG). Reassignment of an entire NXX can be via per occasion agreements among BellSouth, AT&T and the LERG administrators. Updates to translations in the BellSouth switching office from which the telephone number is ported will be made by BellSouth prior to the date on which LERG changes become effective, in order to redirect calls to the AT&T switch via route indexing.

2.4 **Other Interim Portability Provisions**

2.4.1 BellSouth shall exchange with AT&T, SS7 TCAP messages as required for the implementation of Custom Local Area Signaling Services (CLASS) or other features available in the BellSouth network.

UB

- 2.4.2 BellSouth shall notify AT&T of any technical or capacity limitations that would prevent use of a requested interim LNP implementation in a particular switching office. BellSouth and AT&T shall cooperate in the process of porting numbers to minimize customer out-of-service time.
- 2.4.2.1 For a coordinated cutover environment (where the loop is being purchased by AT&T as an unbundled network element at the time of INP implementation), BellSouth shall update switch translations, where necessary, as close to the requested time as possible, using best efforts not to exceed thirty (30) minutes after the physical cutover is completed.
- 2.4.2.2 For a non-coordinated cutover environment (where the loop is supplied by AT&T), BellSouth shall schedule a mechanized update of switch translations at the AT&T requested cutover time (frame due time). In the event that AT&T requires a change to the requested cutover time, AT&T shall notify the BellSouth Local Carrier Service Center a minimum of three (3) hours prior to the frame due time to arrange for a new frame due time. BellSouth shall update switch translations where necessary as close to the requested time as possible, using best efforts not to exceed thirty (30) minutes after the physical cutover is completed.
- 2.4.3 AT&T shall have the right to use the existing BellSouth 911 infrastructure for all 911 capabilities. With respect to 911 service associated with ported numbers under INP, BellSouth agrees that all ported directory numbers (DN) will remain in the Public Service Answering Points (PSAP) routing databases. When RCF is used, both the ported numbers and shadow numbers for AT&T ported subscribers shall be stored in PSAP databases. AT&T shall have the right to verify the accuracy of the information in the PSAP databases.
- 2.4.4 BellSouth shall bill and AT&T shall pay the rates set forth in Part IV of this Agreement for INP. Billing and payment shall be in accordance with the applicable terms and conditions set forth in this Rates Agreement.

3. Permanent Number Portability (PNP)

PNP is currently being worked in industry forums. The results of these forums will dictate the industry direction of PNP. BellSouth agrees to implement PNP as directed by the FCC in FCC Docket 95-116 and the appropriate industry forums.

4. Requirements for INP and PNP

4.1 White and Yellow Page Listings



Pursuant in Section 20 of the General Terms and Conditions of the Agreement, BellSouth shall provide and maintain for AT&T one (1) white page and one (1) yellow page (if applicable) listing for each AT&T subscriber that has ported its number from BellSouth, consistent with that specified for Provisioning in this Agreement. The listing and handling of listed and nonlisted telephone numbers will be at least at parity with that provided by BellSouth to its own subscribers.

**4.2 DELETED**

**4.3 Testing**

BellSouth and AT&T shall cooperate in conducting AT&T's testing to ensure interconnectivity between systems. BellSouth shall inform AT&T of any system updates that may affect the AT&T network and BellSouth shall, at AT&T's request, perform tests to validate the operation of the network. Additional testing requirements may apply as specified by this Agreement.

**4.4 Non-Geographical Numbers**

BellSouth shall not be required to provide number portability for non-geographic services (e.g., 500 and 900 NPAs, and 978 NXX number services) under this Agreement.

**4.5 Engineering and Maintenance**

BellSouth and AT&T will cooperate to ensure that performance of trunking and signaling capacity is engineered and managed at levels which are at least at parity with that provided by BellSouth to its subscribers and to ensure effective maintenance testing through activities such as routine testing practices, network trouble isolation processes and review of operational elements for translations, routing and network fault isolation. Additional specific engineering and maintenance requirements shall apply as specified in this Agreement.

**4.6 BellSouth shall provide AT&T with accurate billing and Customer Account Record Exchange data for AT&T subscribers whose numbers have been ported.**

**4.6.1 DELETED**

**4.6.2 DELETED**

**4.6.3 DELETED**

**4.6.4 DELETED**

*MB*

4.7 Operator Services and Directory Assistance

With respect to operator services and directory assistance associated with LNP for AT&T subscribers, BellSouth shall provide the following:

4.7.1 While INP is deployed and prior to conversion to PNP:

4.7.1.1 If requested by AT&T, BellSouth shall provide Emergency Interrupt (EI) Trunks to the AT&T End Office for BLV/BLI call requests for lines that terminate at the AT&T End Office.

4.7.1.2 When a BLV/BLI request for a ported number is directed to a BellSouth operator and the query is not successful (i.e., the request yields an abnormal result), the operator shall confirm whether the number has been ported and shall direct the request to the appropriate operator.

4.7.1.3 When a customer chooses AT&T as its local services provider and as a result such customer's number is ported to AT&T, BellSouth shall remove from its Line Information Data Base (LIDB) all existing BellSouth issued Telephone Line Number (TLN)-based card numbers when a customer ports their number to AT&T.

4.7.1.4 BellSouth shall allow AT&T to order provisioning of TLN calling cards and Billed Number Screening (BNS), in its LIDB, for ported numbers, as specified by AT&T. BellSouth shall continue to allow AT&T access to its LIDB. Other LIDB provisions are specified in this Agreement.

4.7.1.5 Where BellSouth has control of directory listings for NXX codes containing ported numbers, BellSouth shall maintain entries for ported numbers as specified by AT&T.

4.7.2 DELETED

4.7.2.1 DELETED

4.7.2.2 DELETED

4.7.2.3 DELETED

4.7.2.4 DELETED

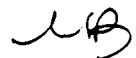

TABLE OF CONTENTS

	<u>PAGE</u>
NETWORK SECURITY .....	1
1. Protection of Service and Property .....	1
2. Revenue Protection .....	2
3. Law Enforcement Interface .....	3

*LIB*

NETWORK SECURITY

1. Protection of Service and Property

BellSouth shall exercise the same level of care it provides itself to prevent harm or damage to AT&T, its employees, agents or customers, or their property. BellSouth agrees to take reasonable and prudent steps to ensure the adequate protection of AT&T property located within BellSouth Premises including, but not limited to:

- 1.1 Restricting access to AT&T equipment, support equipment, systems, tools and data, or spaces which contain or house AT&T equipment enclosures, to AT&T employees and other authorized non-AT&T personnel to the extent necessary to perform their specific job function.
- 1.2 Assuring that the physical security and the means of ingress and admission to spaces that house AT&T equipment or equipment enclosures are equal to or exceed those provided for BellSouth pursuant to BellSouth Admissions Practices.
- 1.3 DELETED
- 1.4 DELETED
- 1.5 DELETED
- 1.6 DELETED
- 1.7 Limiting the keys used in its keying systems for spaces which contain or house AT&T equipment or equipment enclosures to its employees and representatives for emergency access only. AT&T shall further have the right to change locks on all spaces where deemed necessary for the protection and security of such spaces. In such an event, AT&T shall provide BellSouth with replacement keys.
- 1.8 Insuring that doors that provide access to AT&T equipment enclosures are equipped to protect against removal of hinge pins.
- 1.9 DELETED
- 1.10 DELETED
- 1.11 DELETED



1.12 **Installing controls and logical security:**

- to disconnect a user for a pre-determined period of inactivity on authorized ports.
- to protect customer proprietary information; and
- to databases to ensure both ongoing operational and update integrity
- to assure that all approved system and modem access be secured through security servers and that access to or connection with a network element shall be established through a secure network or security gateway.
- to provide security in accordance with BellSouth BSP008-140-230BT (Design, Development, Maintenance and Administration Security Standards for Network Elements, Network Element Support Systems, and other Computer Systems.)

1.13 **DELETED**

2. **Revenue Protection**

2.1 Where BellSouth services are being resold and where AT&T is using a BellSouth port, AT&T will have the use of all present and future fraud prevention or revenue protection features, including prevention, detection, or control functionality embedded within any of the network elements available to BellSouth. These features include, but are not limited to, screening codes, call blocking of international, 800, 900, and 976 numbers.

2.2 The party causing a provisioning, maintenance or signal network routing error that results in uncollectible or unbillable revenues to the other party shall be liable for the amount of the revenues lost by the party unable to bill or collect the revenues less costs that would have been incurred from gaining such revenues. The process for determining the amount of the liability will be as set forth in Attachment 7, Section 6 of this Agreement.

Uncollectible or unbillable revenues resulting from the accidental or malicious alteration of software underlying Network Elements or their subtending operational support systems by unauthorized third Parties shall be the responsibility of the Party having administrative control of access to said Network Element or operational support system software to the extent such unbillable or uncollectible revenue results from the gross negligence or willful act or omission of the Party having such administrative control.



- 2.3 BellSouth shall be responsible for any uncollectible or unbillable revenues resulting from the unauthorized physical attachment to loop facilities from the Main Distribution Frame up to and including the Network Interface Device, including clip-on fraud to the extent such unbillable or uncollectible revenue results from the gross negligence or willful act or omission of BellSouth. BellSouth shall provide soft dial tone to allow only the completion of calls to final termination points required by law.

3. Law Enforcement Interface

BellSouth shall provide seven day a week/ twenty-four hour a day installation and information retrieval pertaining to traps, assistance involving emergency traces and information retrieval on customer invoked CLASS services, including call traces requested by AT&T Security/Network services. BellSouth shall provide all necessary assistance to facilitate the execution of wiretap or dialed number recorder orders from law enforcement authorities.

ACRONYM	DEFINITION
AAA	American Arbitration Association
ABSBH	Average Busy Season Busy Hour
ACD	Automatic Call Distributor
AIN	Advanced Intelligent Network
ALEC	Alternative Local Exchange Carrier
ALI/DMS	Automatic Location Identification/Data Management Systems
AMA	Automated Message Accounting
ANSI	American National Standards Institute
ARPM	Average Revenue Per Message
ARS	Automatic Route Selection
ARU	Automatic Response Unit
ATIS	Alliance for Telecom Industry Solutions
ATM	Asynchronous Transfer Mode
B	Bearer
BACR	Billing Account Cross Reference
BAN	Billing Account Number
BAR	Billing Account Reference
BICI	Broadband Inter-Carrier Interface
BITS	Building Integrated Timing Supply
BLV	Busy Line Verification
BLV/ELI	Busy Line Verification/Emergency Line Interrupt
BNS	Billed Number Screening
BOC	Bell Operating Company
BOS	Billing Output Specifications
BRI	Basic Rate ISDN
BRCS	Business and Residential Customer Service
C	Network Element Combination
C-DTTA	Combo of Dedicated Transport & Tandem
C-LPLS	Combo of Loop & Local Switching
CABS	Carrier Access Billing Systems
CAMA ANI	Centralized Automatic Message Accounting - Automatic Number Identification
CAP	Competitive Access Provider
CCITT	Consultative Committee on International Telegraph & Telephone
CCL	Common Carrier Line
CCS	Communications Channel Signaling
CCS7	Common Channel Signaling System 7
CCSNIS	Common Channel Signaling Network Interface Specification
CI	Customer Interface

CIC	Carrier Identification Code
CF/B	Call Forward on Busy
CF-B/DA	Call Forward on Busy/Don't Answer
CF/DA	Call Forward Don't Answer
CgPN	Calling Party Number
CLASS	Custom Local Area Signaling Service
CLASS/LASS	Customer Local Area Signaling Services
CLC	Carrier Liaison Committee
CLEC	Competitive Local Exchange Carrier
CLLI	Common Language Location Identifier
CMDS	Centralized Message Distribution System
CMIP	Coded Mark Inversion Protocol
CN	Charge Number
CO	Central Office
CPE	Customer Premises Equipment
CRDD	Customer Requested Due Dates
CSD	Circuit Switched Data
CT	Common Transport
CY	Current Year
D	Data
DA	Directory Assistance
DACS	Digital Access Crossconnect Systems
DB	Database
DB	Service Central Points/Databases
DCC	Data Communications Channel
DCMS	Digital Circuit Multiplication Systems
DCS	Digital Cross-Connect System
DDD	Desired Due Date
DID	Direct Inward Dialing
DLC	Digital Loop Carrier
DLCI	Data Link Connection Identifier
DMOQs	Direct Measures of Quality
DN	Directory Numbers
DN-RI	Directory Number - Route Index
DS-1	Digital Signal Level One
DS-3	Digital Signal Level Three
DSAP	Due Date Support Application
DS0	Digital Signal Level Zero
DSI	Digital Speech Interpolation
DSN	Data Set Name
DSX	Digital Cross Connect
DT	Dedicated Transport
DTMF	Dual-Tone Multi Frequency

DTN	Destination Telephone Number
E	Network Element
E&M	Ear & Mouth Signaling
E-LP	Element Loop
EAMF	Equal Access Multi-Frequency
EBCDIC	Extended Binary-Coded Decimal Interexchange Code
EBI	Electronic Bonding Interface
EDD	Envelope Delay Distortion
EDI	Electronic Data Interchange
EFT	Electronic Fund Transfer
EI	Electronic Interface
EI	Emergency Interrupt
ELI	Emergency Line Interrupt
ERL	Echo Return Loss
EMR	Exchange Message Record
EO	End Office
ERMA	Engineering Records Mark-up and Assignment
ES	Errored Second
ESF	Extended Super Frame
ESL	Essential Service Line
ETTR	Estimated Time to Repair
FCC	Federal Communications Commission
FDI	Feeder Distribution Interface
FN	Fiber Node
FOC	Firm Order Confirmation
FRF	Frame Relay Forum
FUNI	Framebased User to Network Interface
GTT	Global Title Translation
HDBH	High-day Busy Hour
HDT	Host Digital Terminal
HFC	Hybrid Fiber Coax
HFC-HDT	Hybrid Fiber Coax - Host Digital Terminal
IBC	Initial Billing Company
ICM	Intelligent Loop Concentrator/Multiplexer
ICS	Inter-Company Settlements
ID	Remote Identifiers
IEC	Interexchange Carrier
IECs	Interexchange Carriers
IEEE	Institute of Electrical and Electronic Engineers
IISP	Interim Interswitch Signaling Protocol
ILEC	Incumbent Local Exchange Carrier
IMD	Intermodulation Distortion
INA	Integrated Network Access

*LB*

NP	Interim Number Portability
IPP	Independent Payphone Provider
ISDN	Integrated Services Digital Network
ISDNUP	Integrated Services Digital Network User Part
ISNI	Intermediate Signal Network Identifier
ISO	International Standardization Organization
ISUP	Integrated Services User Part
ITU	International Telecommunications Union
IVMS	Interswitch Voice Messaging Service
IXC	Interexchange Carriers
LARG	LIDB Access Routing Guide
LASS	Local Area Signaling Services
LATA	Local Access Transport Area
LC	Loop Concentrator/Multiplexor
LCC	Line Class Code
LCSC	Local Carrier Service Center
LD	Loop Distribution
LEC	Local Exchange Carrier
LEC DA	LEC Directory Assistance
LEC SCE	LEC Service Creation Environment
LEC SCP	LEC Service Control Point
LEC SMS	LEC Service Management System
LEC SSP	LEC Service Switching Point
LERG	Local Exchange Routing Guide
LF	Loop Feeder
LGX	Lightguide Cross-Connect
LIDB	Line Information Data Base
LMI	Local Management Interface
LNP	Local Number Portability
LOF	Loss of Frame
LOS	Loss of Signal
LP	Loop
LRECL	Logical Record Length
LRN	Local Routing Number
LS	Local Switching
LSO	Local Serving Office
LSSGR	LATA Switching Systems Generic Requirements
MDF	Main Distribution Frame
MDU	Multiple Dwelling Unit
MDU/BCL	Multiple Dwelling Unit/Business Customer Location
MF	Multi-Frequency
MIB	Management Information Base
MLT	Mechanized Loop Tests

MCP	Methods of Procedure
MOS	Modified Operator Services
MPB	Meet-Point Billing
MR	Modification Request
MRVT	MTP Routing Verification Test
MSAG	Master Street & Address Guide
MTP	Message Transfer Port
MTTR	Mean Time to Repair
MWI	Message Waiting Indicator
NCS	National Communications System
NEBS	Network Equipment Building System
NEC	National Electrical Code
NECA	National Exchange Carrier Association
NESC	National Electrical Safety Code
NGDLC	Next Generation Digital Loop Carrier
NI	Network Interface Device
NID	Network Interface Device
NIU	Network Interface Unit
NMS	Network Management System
NNI	Network to Network Interface
NSEP	National Security Emergency Preparedness
NVT	Network Validation Test
OAM	Operation and Maintenance
OAM&P	Operations Administration Maintenance & Provisioning
OBF	Open & Billing Forum
OC	Optical Carrier
OSHA	Occupational Safety and Health Act
ODS	Optical Distribution
OLI	Originating Line Indicator
OMAP	Operations, Maintenance & Administration Part
OOF	Out-of-Frame
ORT	Operational Readiness Test
OS	Operator Services
OSPS	Operator Services Position System
OSS	Operations Support Systems
OSSGR	Operator Services Systems Generic Requirements
OTS	Operator Transfer Service
PBX	Private Branch Exchange
PDD	Post Dial Delay
PDH	Plesiochronous Digital Hierarchy
PEC	Primary Exchange Carrier
PIC	Primary Interexchange Carrier
PLU	Percent Local Usage

PNP	Permanent Number Portability
POI	Point of Interface
POI	Points of Interconnection
POT	Point of Termination
POTS	Plain Old Telephone Service
PRI	Primary Rate Interface
PSAP	Public Safety Answering Point
PSD	Packet Switched Data
P/SIMS	Products and Services Inventory Management System
PSTN	Public Switched Telecommunications Network
PUC	Public Utilities Commission
RAO	Revenue Accounting Office
RCF	Remote Call Forwarding
RECFM	Record Format
RI	Route Index
RIC	Residual Interconnection Charges
RI-PH	Route Index - Portability Hub
ROW	Right of Way
RPC	Regional Processing Center
RSAG	Regional Street Address Guide
RSM	Remote Switch Module
RT	Remote Terminal
SAG	Street Address Guide
SBC	Subsequent Billing Company
SCCP	Signaling Connection Control Point
SCD	Signal Correlated Distortion
SCE	Service Creation Environment
SCP	Service Control Points
SDH	Synchronous Digital Hierarchy
SECAB	Small Exchange Carrier Access Billing
SES	Severely Errored Second
SFE	Short Failure Event
SL	Signaling Link Transport
SMDI	Standard Message Desk Interface
SMDI-E	Standard Message Desk Interface - Enhanced
SMS	Service Management System
S/N	Signal-to-Noise Ratio
SNMP	Simple Network Management Protocol
SONET	Synchronous Optical Network
SPOC	Single Point of Contact
SPOI	Signaling Point of Interconnection
SRVT	SCCP Routing Verification Test
SS	SS7 Message Transfer & Connection Control



SS7	Signaling System 7
SSP	Switching Services Port
STP	Signaling Transfer Point
STPS	Signaling Transfer Point Switch
STS	Synchronous Transport Signal
SWF-DSI	Switched Functional DS1 Service Capability
T&M	Time & Material
TCAP	Transaction Capabilities Application Port
TDEV	Time Deviation
TDI	Tie Down Information
TELRIC	Total Element Long Run Incremental Cost
THDBH	Ten-High-Day Busy Hour
TIA/EIA	Telecommunications Industries Association/Electronic Industries Association
TLN	Telephone Line Number
TR	Technical Requirements
TS	Tandem Switching
TSG	Trunk Sub-Group
TSGR	Transport System Generic Requirements
TSLRIC	Total Service Long Run Incremental Cost
TSP	Telecommunications Services Priority
UI	Unit Intervals
UNI	User to Network Interface
VB	Variable Block
VCI	Virtual Channel Identifier
VF	Voice Frequency
WDM	Wavelength Division Multiplex
WTN	Working Telephone Number

*MB*

**"Act"** means the Telecommunications Act of 1996.

**"Advanced Intelligent Network (AIN)"** is a network functionality that permits specific conditions to be programmed into a switch which, when met, directs the switch to suspend call processing and to receive special instructions for further call handling instructions in order to enable carriers to offer advanced features and services.

**"Affiliate"** is as defined in the Act.

**"Agreement"** has the meaning set forth in Section 1 of the General Terms and Conditions.

**"AMA"** means the Automated Message Accounting structure inherent in switch technology that initially records telecommunication message information. AMA format is contained in the Automated Message Accounting document, published by Bellcore as GR-1100-CORE which defines the industry standard for message recording.

**"Ancillary Functions"** has the meaning set forth in Part 3 of the General Terms and Conditions.

**"Applicable Law"** is as defined in Section 22.6 of the General Terms and Conditions.

**"Arbitrator(s)"** is the person or persons selected by the Parties to serve as Arbitrator(s) for any dispute submitted to arbitration pursuant to the Dispute Resolution Process outlined in Attachment 1.

**"As Defined in the Act"** means as specifically defined by the Act and as interpreted in the duly authorized rules and regulations of the FCC or Commission.

**"AT&T"** has the meaning set forth in the Preface.

**"AT&T Customer"** means any business or residential customer for AT&T services.

**"Automatic Location Identification/Data Management System (ALI/DMS)"** means the emergency services (E911/911) database containing customer location information (including name, address, telephone number, and sometimes special information from the local service provider) used to determine to which Public Safety Answering Point ("PSAP") to route the call.

MB  
6/10/97

**"Automatic Route Selection (ARS)"** is a service feature that provides for automatic selection of the least expensive or most appropriate transmission facility for each call based on criteria programmed into the system.

**"Bellcore"** means Bell Communications Research, Inc.

**"BellSouth"** has the meaning set forth in the preface.

**"BellSouth Customers"** means any business or residence customer for BellSouth services.

**"Bill and Keep"** is a reciprocal compensation arrangement whereby the compensation that one company offers to another for the completion of its calls is the agreement to complete the other company's calls in a like manner.

**"BLV/BLI (Busy Line Verify/Busy Line Interrupt) Traffic" or "BLV/BLI Call"** means an operator call in which the end user inquires as to the busy status of, or requests an interruption of, a call on an Exchange Service.

**"Bona Fide Request"** has the meaning ascribed to such term in Attachment 14.

**"CABS"** means the Carrier Access Billing System which is contained in a document prepared under the direction of the Billing Committee of the OBF. The Carrier Access Billing System document is published by Bellcore in Volumes 1, 1A, 2, 3, 3A, 4 and 5 as Special Reports SR-OPT-001868, SR-OPT-001869, SR-OPT-001871, SR-OPT-001872, SR-OPT-001873, SR-OPT-001874, and SR-OPT-001875, respectively, and contains the recommended guidelines for the billing of access and other connectivity services.

**"CENTREX"** means a Telecommunications Service that uses central office switching equipment for call routing to handle direct dialing of calls, and to provide many private branch exchange-like features and includes BellSouth's ESSX®, MultiServe®, Prestige® services.

**"CLASS (Custom Local Area Signaling Service) and Custom Features"** means a grouping of optional enhancements to basic local exchange service that offers special call handling features to residential and single-line business customers (e.g., call waiting, call forwarding and automatic redial).

**"Claim"** has the meaning ascribed to such term in Section 10.4 of the General Terms and Conditions.

**"Collocation"** has the meaning set forth in Attachment 3, Section 2.1.



FL6/10/97

**"Combinations"** consist of multiple Network Elements that are logically related to enable AT&T to provide service in a geographic area or to a specific customer and that are placed on the same order by AT&T.

**"Commission"** means State Commission as Defined in the Act.

**"Common Transport"** has the meaning set forth in Attachment 2, Section 9.1.

**"Conduit"** has the meaning set forth in Attachment 3, Section 3.

**"Confidential Information"** means confidential or proprietary technical or business information given by the Discloser to the Recipient and further defined in Section 18.1 of the General Terms and Conditions.

**"Contract Year"** means a twelve (12) month period during the term of the contract commencing on the Effective Date and each anniversary thereof.

**"Cooperative Testing"** has the meaning set forth in Attachment 2, Section 16.1.1.

**"CRIS/CLUB"** means Customer Record Information System/Customer Local Usage Billing.

**"Customer Proprietary Network Information (CPNI)"** is as defined in the Act.

**"Customer Usage Data"** means the local Telecommunications Services usage data of an AT&T Customer, measured in minutes, sub-minute increments, message units, or otherwise, that is recorded by BellSouth and forwarded to AT&T.

**"Dark Fiber"** has the meaning set forth in Attachment 2, Section 15.1.1.

**"Databases"** has the meaning set forth in Attachment 2, Section 13.1.1.

**"Dedicated Transport"** has the meaning set forth in Attachment 2, Section 10.1.1.

**"Defaulting Party"** is a Party in breach of a material term or condition of the Agreement.

**"Digital Cross-Connect System"** has the meaning set forth in Attachment 2, Sections 10.5.1.1 and 10.5.1.2.



FL6/10/97

**"Directory Listings"** has the meaning set forth in Section 20.1 of the General Terms and Conditions.

**"Directory Assistance Service"** has the meaning set forth in Attachment 2, Section 8.3.

**"Discloser"** means that Party to this Agreement which has disclosed Confidential Information to the other Party.

**"Dispute Resolution Process"** is the process described in Section 16 of the General Terms and Conditions and Attachment 1 which has been agreed to by the Parties for resolution of disputes.

**"Distribution Media"** has the meaning set forth in Attachment 2.

**"Effective Date"** is the date indicated in the Preface on which the Agreement shall become effective.

**"EMR"** means the Exchange Message Record System used among LECs for exchanging telecommunications message information for billable, non-billable, sample, settlement and study data. EMR format is contained in BR-010-200-010 CRIS Exchange Message Record, published by Bellcore and which defines the industry standard for exchange message records.

**"Environmental Hazard"** means (1) a release, discharge, leak, spill or disposal (collectively referred to hereafter as "release") of HAZARDOUS MATERIALS has occurred on premises or property that is related to the performance of this Agreement and that such affected material or media is demonstrated through applicable or appropriate testing method to require remediation or removal as determined by all laws, ordinances, statutes, codes, rules, regulations, orders and decrees of the United States, the state, county, city or any other political subdivision in which the release has occurred, and any other political subdivision, agency or instrumentality exercising jurisdiction over the release, including any applicable federal and state case law and common law interpreting any of the foregoing or (2) any event involving, or exposure to, HAZARDOUS MATERIALS which poses risks to human health, safety or the environment (including, without limitation, indoor or outdoor environment(s) and is regulated under any applicable laws or regulations as described in (1).

**"Enhanced White Pages"** means optional features available for White Pages Directory listings (e.g., bold, all capitals, additional line of text, indented).

**"Enhanced Yellow Pages"** means optional features available for Yellow Pages Directory listings (e.g., red type, bold, all capitals, additional line of text).



FL6/10/97

(indented)

**"E911 Service"** is a method of routing 911 calls to a PSAP that uses customer location data in the ALI/DMS to determine the PSAP to which a call should be routed.

**"Filing"** has the meaning set forth in Section 9.2 of the General Terms and Conditions.

**"Follow-on Agreement"** has the meaning set forth in Section 2.2 of the General Terms and Conditions.

**"Governmental Authority"** means any federal, state, local, foreign or international court, government, department, Commission, board, bureau, agency, official, or other regulatory, administrative, legislative or judicial authority with jurisdiction.

**"Hazardous Materials"** means any hazardous or toxic substance, material or waste listed in the United States Department of Transportation HAZARDOUS MATERIALS Table at 49 CFR 172.101; any hazardous substance listed by the Environmental Protection Agency (EPA) under the Comprehensive Environmental, Response, Compensation, and Liability Act (CERCLA), 42 U.S.C. §§ 9601 et. seq., as amended, and found at 40 CFR Part 302; any hazardous waste listed under the Resource Conservation and Recovery Act (RCRA), 42 U.S.C. §§ 6901 et. seq., as amended, and found at 40 CFR Part 261; any toxic substance regulated by the Toxic Substances Control Act, 15 U.S.C. §§ 2601 et. seq., as amended; any insecticide, fungicide, or rodenticide regulated by the Federal Insecticide, Fungicide, and Rodenticide Act, 7 U.S.C. §§ 136 et. seq.; and the following specified substances or materials, that may or may not be regulated by the above: (1) asbestos or asbestos-containing materials; (2) petroleum or petroleum-based or derived products or by-products; (3) polychlorinated biphenyls (PCBs); and (4) radon.

**"Interconnection"** is as described in the Act and refers to the linking of two or more telecommunications networks for the purpose of terminating local telephone calls.

**"Interim Number Portability (INP)"** is as described in the Act and means the delivery of LNP capabilities, from a customer standpoint in terms of call completion, with as little impairment of functioning, quality, reliability, and convenience as possible and from a carrier standpoint in terms of compensation, through the use of existing and available call routing, forwarding, and addressing capabilities.

**"Line Information Data Base(s) (LIDB)"** means one or all, as the context may require, of the Line Information Databases owned individually by ILECs and other entities which provide, among other things, calling card validation functionality for telephone line number cards issued by ILECs and other entities. A LIDB also contains validation data for collect and third number-billed calls, which include billed number screening.

**"Local Exchange Carrier"** is as defined in the Act.

**"Local Number Portability (LNP)"** means Interim Number Portability (INP) or Permanent Number Portability (PNP).

**"Local Number Portability Database"** supplies routing numbers for calls involving numbers that have been ported from one local service provider to another and is further defined in Attachment 2, Section 13.3.1.

**"Local Service"** has the meaning set forth in Section 1 of the General Terms and Conditions.

**"Local Switching"** has the meaning set forth in Attachment 2, Section 7.1.

**"Local Traffic"** - means any telephone call that originates and terminates in the same LATA and is billed by the originating Party as a local call, including any call terminating in an exchange outside of BellSouth's service area with respect to which BellSouth has a local interconnection agreement with an independent LEC, with which AT&T is not directly interconnected.

**"Loop" or "Loop Combination"** has the meaning set forth in Attachment 2, Section 2.1.1.

**"Loop Concentrator/Multiplexer"** has the meaning set forth in Attachment 2, Section 5.1.

**"Loop Distribution"** has the meaning set forth in Attachment 2, Section 4.

**"Loop Feeder"** has the meaning set forth in Attachment 2, Section 6.1.1.

**"MECAB"** means the Multiple Exchange Carrier Access Billing document prepared under the direction the Billing Committee of the OBF. The Multiple Exchange Carrier Access Billing document, published by Bellcore as Special Report SR-BDS-000983, contains the recommended guidelines for the billing of access and other connectivity services provided by two or more LECs (including LECs and CLECs), or by one LEC or CLEC in two or more states within a single LATA.

  
FL6/10/97

**"MECOD"** means the Multiple Exchange Carriers Ordering and Design (MECOD) Guidelines for Access Services- Industry Support Interface, a document developed under the auspices of the Billing Committee of the OBF. The MECOD document, published by Bellcore as Special Report SR STS-002643, establishes recommended guidelines for processing orders for access and other connectivity services which is to be provided by two or more LECs (including LECs and CLECs), or by one LEC or CLEC in two or more states within a single LATA.

**"Network Element"** is as defined in the Act.

**"Network Interface Device"** has the meaning set forth in Attachment 2, Section 4.1.1.1.

**"911 Service"** means a universal telephone number which gives the public direct access to the PSAP. Basic 911 service collects 911 calls from one or more local exchange switches that serve a geographic area. The calls are then sent to the correct authority designated to receive such calls.

**"OBF"** means the Ordering and Billing Forum (OBF), which functions under the auspices of the Carrier Liaison Committee (CLC) of the Alliance for Telecommunications Industry Solutions (ATIS).

**"Operator Systems"** has the meaning set forth in Part I, Section 30.9.5.

**"OUTPLOC"** is as described in Section 28.6.22 of Part I of the Agreement.

**"Parties"** means AT&T and BellSouth.

**"Permanent Number Portability (PNP)"** means the use of the Local Routing Number (LRN) database solution to provide fully transparent LNP for all customers and all providers without limitation.

**"Pole Attachment"** has the meaning set forth in Attachment 3.

**"Premises"** is as defined in the Act.

**"Public Safety Answering Point (PSAP)"** means the designated agency to which calls to E911/911 services are routed.

**"Real Time"** means the actual time in which an event takes place, with the reporting on or the recording of the event practically simultaneous with its occurrence.



**"Recipient"** means that Party to this Agreement to which Confidential Information has been disclosed by the other Party

**"Recorded Usage Data"** has the meaning set forth in Attachment 7 Section 3.1.

**"Release"** means any release, spill, emission, leaking, pumping, injection, deposit, disposal, discharge, dispersal, leaching, or migration, including without limitation, the movement of Environmental Hazards through or in the air, soil surface water or groundwater, or any action or omission that causes Environmental Hazards to spread or become more toxic or more expensive to investigate or remediate.

**"Retail Rates"** means the lowest prices that BellSouth actually charges its customers.

**"Rights of Way (ROW)"** has the meaning set forth in Attachment 3.

**"RLEC"** The terms Regional Local Exchange Company ("RLEC"), Local Exchange Company ("LEC"), and Incumbent Local Exchange ("ILEC") are used interchangeably throughout this Agreement.

**"SECAB"** means the Small Exchange Carrier Access Billing document prepared by the Billing Committee of the OBF. The Small Exchange Carrier Access Billing document, published by Bellcore as Special Report SR OPT - 001856, contains the recommended guidelines for the billing of access and other connectivity services.

**"Served Premises"** means collectively, the AT&T designated locations to which AT&T orders Network Elements, Ancillary Functions or Combinations.

**"Service Control Point"** has the meaning set forth in Attachment 2, Section 13.1.2.

**"Services and Elements"** means collectively Local Services, Network Elements, Combinations, Ancillary Functions, and Additional Features.

**"Service Order"** means the placement of an order for Services or Elements.

**"Signaling Link Transport"** has the meaning set forth in Attachment 2, Section 11.1.

**"Signaling Transfer Points"** has the meaning set forth in Attachment 2, Section 12.1.



FL6/10/97

"SS7 Network Interconnection" has the meaning set forth in Attachment 2, 15.5.1

"Synchronization" has the meaning set forth in Attachment 2, Section 15.4.1

"Tandem Switching" has the meaning set forth in Attachment 2, 14.1

"Telephone Relay Service" provides to speech and hearing-impaired callers a service that enables callers to type a message into a telephone set equipped with a keypad and message screen and to have a line operator read the message to a recipient and to relay message recipients' response to the speech or hearing-impaired caller.

"Total Element Long Run Incremental Cost (TELRIC)" is the cost of the forward looking least cost technology of providing a service, relevant group of services, or basic network elements, given that the company already produces all of its services. Alternatively, TELRIC represents the costs avoided if the telecommunications provider had never offered the particular service, group of services, or network element in question.

"Voluntary Federal Customer Financial Assistance Programs" are Telecommunications Services provided to low-income subscribers, pursuant to requirements established by the appropriate state regulatory body.

"Waste" means all hazardous and non-hazardous substances and materials which are intended to be discarded, scrapped, or recycled, associated with activities AT&T or BellSouth or their respective contractors or agents perform at Work Locations. It shall be presumed that all substances or materials associated with such activities, that are not in use or incorporated into structures (including without limitation damaged components or tools, leftovers, containers, garbage, scrap, residues or byproducts), except for substances and materials that AT&T, BellSouth or their respective contractors or agents intend to use in their original form in connection with similar activities, are Waste. "Waste" shall not include substances, materials or components incorporated into structures (such as cable routes) even after such components or structure are no longer in current use.

"Work Locations" means any real estate that BellSouth owns, leases or licenses or in which it holds easements or other rights to use, or does use, in connection with this Agreement.

PERFORMANCE MEASUREMENT

1 PERFORMANCE MEASUREMENT - DMOQ's

1.1 BellSouth, in providing Services and Elements to AT&T pursuant to this Agreement, shall provide AT&T the same quality of service that BellSouth provides itself and its end-users. This Attachment 12 includes AT&T's minimum service standards and measurements for those requirements. The Parties have agreed to five (5) categories of DMOQs: (1) Provisioning; (2) Maintenance; (3) Billing (Data Usage and Data Carmer); (4) LIDB; and (5) Account Maintenance. The measurements are summarized on Appendix I of this Attachment 12 which is incorporated herein by reference. Each category of DMOQ includes measurements which focus on timeliness, accuracy and quality. BellSouth shall measure the following activities to meet the goals provided herein.

1.2 All DMOQs shall be measured on a monthly basis and shall be reported to AT&T in a mutually agreed upon format which will enable AT&T to compare BellSouth's performance for itself with respect to a specific measure to BellSouth's performance for AT&T for that same specific measure. Separate measurements shall be provided for residential customers and business customers.

1.3 DMOQs being measured pursuant to this Agreement shall be reviewed by AT&T and BellSouth quarterly to determine if any additions or changes to the measurements and the standard shall be required or, if process improvements shall be required.

2. PROVISIONING DMOQs

2.1 Installation functions performed by BellSouth will meet the following DMOQs:

**Desired Due Date:** (The following intervals are being provided until such time that desired due date is implemented. The performance target for each interval is that 98% of all intervals will be met).

*NB*

Service	Interval
INSTALLATION	
Lines/trunks with no premises visit	
<i>Business</i>	

1-5 lines (NEW)	24 hours
1-20 lines	3 business days
21-40 lines	7 business days
41-60 lines	12 business days
Over 60 lines	To be negotiated
<i>Residential</i>	Within 24 hours of Service Order receipt
Lines/trunks with premises visit	
<i>Business</i>	
1-20 lines	5 business days
21-40 lines	10 business days
41-60 lines	14 business days
Over 60 lines	Individual case basis
<i>Residential</i>	Within 72 hours of Service Order receipt
Business lines/trunks; plant or other facilities not available	Individual case basis
Centrex station lines	
1-20 lines	5 business days
21-50 lines	8 business days
Over 50 lines	Individual case basis
Unbundled switching elements	
<i>Business or Residential</i>	2 business days
Other unbundled elements	

*MB*

<i>Business or Residential</i>	5 business days
<b>FEATURE CHANGES</b>	
Orders received before 12:00pm	Completed on day of receipt
Orders received after 12:00pm	Completed before 12:00pm next business day
<b>SERVICE DISCONNECTS</b>	
With no premises visits	
<i>Business or Residential</i>	Within 4 hours after receipt of Service Order
With CO change or subscriber premises visit	
<i>Business or Residential</i>	Within 24 hours after receipt of Service Order
Unbundled switching elements	
<i>Business or Residential</i>	Within 4 hours
Other unbundled elements	
<i>Business or Residential</i>	Within 24 hours

**Committed Due Date Met:**

Residence: >99%  
 Business: >99.5%  
 UNE: >98%

**Feature Additions and Changes:**

Order received before 12PM completed on day of receipt 99% of the time

Order received after 12PM completed before 12 PM  
next business day 99% of the time

Service Orders provisioned as requested:

Residence: >99%  
Business: >99.5%  
UNE: >99%

Missed Appointments that require a premise visit:

Residence: <1%  
Business: 0%

Firm Order Confirmation (manual) within 24 hours:  
99% of the time

Firm Order Confirmation (EI) within 4 hours:  
99% of the time

Notice of reject or error status within 1 hour of receipt:  
98% of the time

No trouble reports within 30 days of service order completion:  
99% of the time

### 3. MAINTENANCE DMOQs

- 3.1 Where an outage has not reached the threshold defining an emergency network outage, the following quality standards shall apply with respect to restoration of Local Service and Network Elements or Combination. Total outages requiring a premises visit by a BellSouth technician that are received between 8 a.m. to 6 p.m. on any business day shall be restored within four (4) hours of referral, ninety percent (90%) of the time.

Total outages requiring a premises visit by a BellSouth technician that are received between 6 p.m. and 8 a.m. on any business day and Saturday, Sunday or holiday, shall be restored during the following business day in accordance with the following performance metric: within four (4) hours of 8 a.m., ninety percent (90%) of the time. Total outages which do not require a premises visit by a BellSouth technician shall be restored within two (2) hours of referral, eighty-five percent (85%) of the time.

- 3.2 Trouble calls (e.g., related to Local Service or Network Element or Combination degradation or feature problems) which have not resulted in total service outage shall be resolved within twenty-four (24) hours of referral, ninety-five percent (95%) of the time, irrespective of whether or not resolution requires a premises visit. For purposes of this Section, Local Service or a Network Element or Combination is considered restored, or a trouble resolved, when the quality of the Local Service or Network Element or Combination is equal to that provided before the outage, or the trouble, occurred.
- 3.3 The BellSouth repair bureau shall provide to AT&T the "estimated time to restore" with at least ninety-seven percent (97%) accuracy.
- 3.4 Repeat trouble reports from the same customer in a 30 days period shall be less than one percent (1%). Repeat trouble reports shall be measured by the number of calls received by the BellSouth repair bureau relating to the same telephone line during the current and previous report months.
- 3.5 BellSouth shall inform AT&T at least 95% of the time within ten (10) minutes of restoration of Local Service, Network Element, or Combination after an outage has occurred.
- 3.6 If service is provided to AT&T Customers before an Electronic Interface is established between AT&T and BellSouth, AT&T will transmit repair calls to the BellSouth repair bureau by telephone. In such event, the following standards shall apply: The BellSouth repair bureau shall answer its telephone and begin taking information from AT&T within twenty (20) seconds of the first ring, ninety-five percent (95%) of the time. Calls answered by automated response systems, and calls placed on hold, shall be considered not to meet these standards.
- 3.7 BellSouth will miss meeting end user appointments that require a premise visit less than 1% of the time.

**4. BILLING (CUSTOMER USAGE DATA)**

**4.1 File Transfer**

BellSouth will initiate and transmit all files error free and without loss of signal.

Metric:

$$\frac{\text{Number of FILES Received}}{\text{Number of FILES Sent}} \times 100$$

*LB*

Notes: All measurement will be a on a rolling period

Measurement: 6 months of file transfers  
without a failure

4.2 Timeliness

BellSouth will mechanically transmit, via CONNECT Direct, all usage records to AT&T's Message Processing Center three (3) times a day.

Measurement: 99.94% of all messages delivered on  
the day the call was Recorded.

4.3 Completeness

BellSouth will provide all required Recorded Usage Data and ensure that it is processed and transmitted within thirty (30) days of the message create date.

Metric:

Total number of Recorded Usage Data records delivered during current month minus Number of Usage Call Records held in error file at the end of the current month

-----X 100

Total number of Recorded Usage Data Records delivered during current month

Measurement:  $\geq 99.99\%$  of all records  
delivered

4.4 Accuracy

BellSouth will provide Recorded Usage Data in the format and with the content as defined in the current BellCore EMR document.

Metric:

Total Number of Recorded Usage Data Transmitted Correctly

-----X 100

Total Number of Recorded Usage Data Transmitted

Measurement:  $\geq 99.99\%$  of all recorded  
records delivered

4.5 Data Packs

*AB*

FL6/10/97



BellSouth will transmit to AT&T all packs error free in the format agreed.

Measurement: 6 months of Transmitted  
Packs without a rejected  
pack

Note: All measurements will be on a Rolling Period.

#### 4.6 Recorded Usage Data Accuracy

BellSouth will ensure that the Recorded Usage Data is transmitted to AT&T error free. The level of detail includes, but is not limited to: detail required to Rating the call, Duration of the call, and Correct Originating/Terminating information pertaining to the call. The error is reported to BellSouth as a Modification Request (MR). Performance is to be measured at 2 levels defined below. AT&T will identify the priority of the MR at the time of hand off as Severity 1 or Severity 2. The following are AT&T expectations of BellSouth for each:

Note: Severity 1 is customer affecting.

Measurement:

Severity 1:  $\geq 90\%$  of the MR fixed in  $\leq 24$  hours and 100% of the MR fixed in  $\leq 5$  Days

Severity 2:  $\geq 90\%$  of the MR fixed in 3 Days and 100% of the MR fixed in  $\leq 10$  Days

#### 4.7 Usage Inquiry Responsiveness

BellSouth will respond to all usage inquiries within twenty-four (24) hours of AT&T's request for information. It is AT&T's expectation to receive continuous status reports until the request for information is satisfied.

Measurements: 100% of the Inquires responded to within 24 hours

### 5. BILLING (CONNECTIVITY BILLING AND RECORDING)

5.1 The Parties have agreed to negotiate a pre-bill certification process set forth in Section 12 of Attachment 6. The process shall consider measurement of the following:



**Billing Accuracy:**

- Bill format
- Other charges and credits
- Minutes of use
- Customer Service Record

**Timeliness**

- Bill Delivery
- Service order billing
- Late billing notification
- Correction/adjustment dollars
- Bill period closure cycle time
- Minutes of use charges
- Customer service record

**Customer satisfaction rating**

- 5.2 Until such time when BellSouth forwards connectivity bills in CABS format, BellSouth will meet the following DMOQs:

**Billing Accuracy**

- All rates on paper bill are correct
- All inventory is correct (matches what was ordered and completed, i.e. lines, features and functions)
- All completed orders are billed on the next billing cycle
- All calculations are performed accurately

**Timeliness**

- Deliver bills within 10 days of billing date

**6. LINE INFORMATION DATA BASE (LIDB)**

- 6.1 BellSouth shall provide processing time at the LIDB within 1 second for 99% of all messages under normal conditions as defined in the technical reference in Section 13.8.5 of Attachment 2.

- 6.2 BellSouth shall provide 99.9 % of all LIDB queries in a round trip within 2 seconds as defined in the technical reference in Section 13.8.5 of Attachment 2.

- 6.3 Once appropriate data can be derived from LIDB, BellSouth shall measure the following:

- 6.3.1 There shall be at least a 99.9.% reply rate to all query attempts.

- 6.3.2 Queries shall time out at LIDB no more than 0.1% of the time.

- 6.3.3 Data in LIDB replies shall have at no more than 2% unexpected data values, for all queries to LIDB.
- 6.3.4 Group troubles shall occur for no more than 1% of all LIDB queries. Group troubles include:
  - 6.3.4.1 Missing Group - When reply is returned "vacant" but there is no active record for the 6-digit NPA-NXX group.
  - 6.3.4.2 Vacant Code - When a 6-digit code is active but is not assigned to any customer on that code.
- 6.3.5 There shall be no defects in LIDB Data Screening of responses.

## 7. ACCOUNT MAINTENANCE

- 7.1 When notified by a CLEC that an AT&T Customer has switched to CLEC service, BellSouth shall provision the change, and notify AT&T via CONNECT:Direct that the customer has changed to another service provider ("OUTPLOC") within one (1) business day, 100% of the time.
- 7.2 When notified by AT&T that a customer has changed his/her PIC only from one interexchange carrier to another carrier, BellSouth shall provision the PIC only change and convey the confirmation of the PIC change via the work order completion feed within one (1) business day, 100% of the time.
- 7.3 If notified by an interexchange carrier using an '01' PIC order record that an AT&T Customer has changed his/her PIC only, BellSouth will reject the order and notify that interexchange carrier a CARE PIC record should be sent to the serving CLEC for processing. 100% of all orders shall be rejected and the respective IXC notified within one (1) business day of BellSouth's receipt of the PIC order from the IXC.

APPENDIX I  
LSRAJNE Service Performance Measurements (DMOQs)

DMOQ	Description	Performance Target
<b>Provisioning</b>		
Desired Due Date Intervals	The following intervals are being provided until such time that Desired Due Date is implemented	90%
<b>INSTALLATION</b>		
Lines/Trunks with no premises visit		
Business	24 hours	90%
1-5 lines (NEMO)	3 business days	90%
1-20 lines	7 business days	90%
21-40 lines	12 business days	90%
41-60 lines	To be negotiated	90%
Over 60 lines	Within 24 hours of Service Order receipt	90%
Residential		
Lines/trunks with premises visit		
Business		

car

1-20 lines	5 business days	98%
21-40 lines	10 business days	98%
41-60 lines	14 business days	98%
Over 60 lines	Individual case basis	98%
Residential	Within 72 hours of Service Order receipt	98%
Business lines/units, plant or other facilities not available	Individual case basis	98%
Central station lines		
1-20 lines	5 business days	98%
21-50 lines	8 business days	98%
Over 50 lines	Individual case basis	98%
Unbundled switching elements Business or Residential	2 business days	98%
Other unbundled elements Business or Residential	5 business days	98%

*Handwritten signature or initials*

<p><b>FEATURE CHANGES</b></p> <p>Orders received before 12 00pm</p> <p>Orders received after 12 00pm</p> <p><b>SERVICE DISCONNECTS</b></p> <p>With no premises visits <i>Business or Residential</i></p> <p>With CO change or subscriber premises visit <i>Business or Residential</i></p> <p>Unbundled switching elements <i>Business or Residential</i></p> <p>Other unbundled elements <i>Business or Residential</i></p>	<p>Completed on day of receipt</p> <p>Completed before 12 00pm next business day</p> <p>Within 4 hours after receipt of Service Order</p> <p>Within 24 hours after receipt of Service Order</p> <p>Within 4 hours</p> <p>Within 24 hours</p>	<p>98%</p> <p>98%</p> <p>98%</p> <p>98%</p> <p>98%</p> <p>98%</p>
--	--	---

MB

<p>Committed Due Date Met</p>	<p>Tracks compliance of meeting commitments</p>	<p>&gt;99% LSR Residence &gt;99.5% LSR Business &gt;=98% UNE</p>
<p>Feature additional/change - Order received before 12:00pm, completed on day of receipt - Orders received after 12:00pm, completed before 12:00pm next business day</p>	<p>Measures the committed interval given to AT&amp;T orders requesting feature changes to existing services not requiring a dispatch</p>	<p>99% 99%</p>
<p>Service orders provisioned as requested</p>	<p>Tracks compliance of provisioning services as committed on Firm Order Confirmation</p>	<p>&gt;99% Residence &gt;99.5% Business &gt;=99% UNE</p>
<p>Missed Appointments</p>	<p>Tracks compliance of meeting commitments on appointments that require a premise visit</p>	<p>Residence &lt;=1% Business &lt;=0%</p>

10

<p>Timely Receipt of status notices:</p> <ul style="list-style-type: none"> <li>- Firm Order Confirmation within 24 hours (for paper)</li> <li>- Firm Order Confirmation within 4 hours (for E1)</li> <li>- Notice of Reject or error status within 1 hour of receipt (paper/electronic)</li> </ul>	<p>Supports the ability of the AT&amp;T representative to validate the status of ordered services</p>	<p>99%</p> <p>99%</p> <p>98%</p> <p>&gt;99%</p>
<p>No trouble reported within 30 days of order completion</p>	<p>Measures reliability of service provided to AT&amp;T end users</p>	
<p><b>Maintenance</b></p>		
<p>Time to Restore</p>	<p>Customer out of service and requires a dispatch to premises. Measures from BellSouth trouble receipt to AT&amp;T close out</p>	<p>90% &lt; 4 hours Bus &amp; Res</p>
<p>Out of Service-Dispatch Required</p>	<p>Customer out of service and requires a dispatch to premises. Measures from BellSouth trouble receipt to AT&amp;T close out</p>	<p>85% &lt; 2 hours Bus &amp; Res</p>
<p>Time to Restore</p>	<p>Customer out of service and requires a dispatch to premises. Measures from BellSouth trouble receipt to AT&amp;T close out</p>	<p>95% &lt; 24 hours Bus &amp; Res</p>
<p>Out of Service-No Dispatch Required</p>	<p>Customer out of service and requires a dispatch to premises. Measures from BellSouth trouble receipt to AT&amp;T close out</p>	<p>95% &lt; 24 hours Bus &amp; Res</p>
<p>Time to Restore</p>	<p>Measures accuracy of restored commitment time</p>	<p>&gt;97% of Time Bus &amp; Res</p>
<p>Service Impairment</p>		
<p>Estimated Time to Restore</p>		

*LB*



Repeat Troubles	Customer experiences no repeat troubles within 30 days of a trouble report	< 1% for 30 Days Bus & Res
-----------------	--	-------------------------------

LB

<b>Trouble Resolution Notification</b>	BellSouth notifies AT&T within 10 minutes of a trouble restoral	>95% of Time  Bus & Res
<b>Speed of Answer</b>	Measures that BellSouth begins taking information from AT&T within 20 seconds of first telephone ring	>95% of Time
<b>Missed Appointments</b>	Tracks compliance of meeting commitments on end user appointments	<1%
<b>Billing (Customer Usage Data)</b>		
<b>File Transfer Accuracy</b>	BellSouth will initiate and transmit all files error free and without loss of signal	100% of all files transmitted error free and without loss of signal
<b>Timeliness</b>	BellSouth will mechanically transmit, via CONNECT Direct, all usage records to AT&T's Message Processing Center three (3) times a day.	99.94% of all messages delivered on the day the call was Recorded
<b>Completeness</b>	BellSouth will provide all required Recorded Usage Data and ensure that it is processed and transmitted within thirty (30) days of the message create date.	99.99% of all records delivered
<b>Accuracy</b>	BellSouth will provide Recorded Usage Data in the format and with the content as defined in the current BellCore EMR document	99.99% of all recorded records delivered
<b>Data Packs</b>	BellSouth will transmit all packs error free in the format agreed	100% of all packs transmitted error free
<b>Recorded Usage Data Accuracy</b>  Severity 1	BellSouth will ensure that the Recorded Usage Data is transmitted error free. The level of detail includes: detail to rate the call, duration of the call, Correct Originating and Terminating information pertaining to the call. The error will be reported to BellSouth as a Severity 1 or 2 Modification Request (MR)	> 90% of the MR corrected in < 24 hours and 100% of the MR corrected in < 5 days  > 90% of the MR corrected in 3 days and 100% of the MR

Severity 2	Note: Severity 1 is customer affecting	Corrected in < 10 days
Usage Inquiry Responsiveness	BellSouth will respond to all usage inquiries within twenty four (24) hours of AT&T's request for information. Continuous status reports should be reported until the request for information is satisfied.	100% of inquiries responded to in 24 hours
<b>Billing (Connectivity Billing and Recording)</b>		
Billing Accuracy	AT&T and BellSouth have agreed to negotiate a pre-bill certification process set forth in Attachment 6, Paragraph 12 and Attachment 12, Paragraph 5.1. Until such time when BellSouth forwards connectivity bills in CABS format, BellSouth will follow the measurements outlined in Attachment 12, Paragraph 5.2.	100% of all bills are accurate
Timeliness	AT&T and BellSouth have agreed to negotiate a pre-bill certification process set forth in Section 12 of Attachment 6 and Attachment 12, Paragraph 5.1. Until such time when BellSouth forwards connectivity bills in CABS format, BellSouth will follow the measurements outlined in Attachment 12, Paragraph 5.2.	100% of all bills are timely
<b>Live Information Database</b>		
LIDB processing time within 1 second	Measures timeliness of LIDB processing time under normal conditions	99% of all messages
Roundtrip LIDB queries within 2 seconds	Measures round trip processing time of LIDB queries	99.9%
Reply rate to all query attempts	Measures the reply rate of LIDB query attempts	99.9%
LIDB query timeouts	Measures the frequency of LIDB query timeouts	< 0.1%

ep

Data accuracy of LIDB replies	Measures the accuracy of LIDB data	< 2% unexpected data
Group troubles shall occur for no more than 1% of all LIDB queries.  - Missing group  - Vacant code	When reply is returned vacant but there is no active record for the 6 digit NPA NXX group  When a 6 digit code is active but is not assigned to any customer on that code	< 1%  < 1%
Accuracy of LIDB data screening of responses	Measures the accuracy of the LIDB data screening process	100% accuracy
<b>Account Maintenance</b>		
OUTPLOC (CLEC notifies BellSouth that an AT&T customer has switched Local Service Providers)	When notified by a CLEC that an AT&T customer has switched Local Service Providers, BellSouth shall provision the order, and notify AT&T via CONNECT Direct that the customer has changed to another service provider within one (1) business day, 100% of the time	100% notification within one (1) business day
LD PIC Only Change	When notified by AT&T that a customer has changed only his/her LD PIC from one interexchange carrier to another carrier, BellSouth shall provision the PIC Only Change and convey the confirmation of the PIC Change via the work order completion feed within one (1) business day, 100% of the time.	100% notification within one (1) business day
IXC PIC Reject (Interexchange carrier notifies BellSouth that an AT&T Local Customer has changed his/her LD PIC)	If notified by an interexchange carrier that an AT&T Local Customer has changed his/her LD PIC, BellSouth will reject the order and notify the interexchange carrier that AT&T is the Local Service Provider. 100% of the orders shall be rejected within one (1) business day	100% of the orders rejected within one (1) business day

\* BellSouth's performance under this Agreement shall provide AT&T with the capability to meet standards or other measurements that are at least equal to the level that BellSouth provides itself or is required to provide by law or its own internal procedures

EB

AGREEMENT

In consideration of the mutual promises contained herein, BellSouth Advertising & Publishing Corporation, a Georgia corporation ("BAPCO") and AT&T Corp., a New York corporation ("CARLIER") agree as follows:

1. **RECITALS.** BAPCO is the publisher of alphabetical and classified directories for certain communities in the southeastern region of the U.S. (the "Directories"). CARLIER provides, or intends to provide, local exchange telephone service in communities in which BAPCO publishes Directories. BAPCO and CARLIER have established the terms by which BAPCO will include listings of CARLIER subscribers in such Directories and by which BAPCO will provide such Directories to CARLIER subscribers. BAPCO agrees that it will treat CARLIER as well as all other local exchange carriers consistent with BAPCO's internal standards.

2. **CARLIER OBLIGATIONS.** CARLIER agrees as follows:

- (a) CARLIER shall provide to BAPCO, or its designee, its CARLIER's expense and as no charge, listing information concerning its subscribers (designating not who do not desire published listings), consisting of customer name, address, telephone number and all other information reasonably requested by BAPCO as set forth on Exhibit A for use by BAPCO or its affiliates or agents in publishing Directories of whatever type and format and for other derivative purposes such as electronic directories or publishing. Such subscriber listing information shall be provided in the format and on the schedule set forth in said Exhibit, or as otherwise mutually agreed between the parties from time to time.
- (b) CARLIER shall also provide directory delivery information to BAPCO as set forth in Exhibit A for all subscribers.
- (c) CARLIER shall advise BAPCO promptly of any directory-related inquiries, requests or complaints which it may receive from CARLIER subscribers and shall provide reasonable cooperation to BAPCO in response to or resolution of the same.
- (d) CARLIER shall respond promptly regarding corrections or queries raised by BAPCO in process listing changes requested by subscribers.

3. **BAPCO OBLIGATIONS.** Provided that CARLIER: (1) is entitled by the

applicable state's public service commission for provision of local exchange service; (2) has established appropriate resale or interconnection arrangements with BellSouth Telecommunications, Inc. ("BellSouth") or is pursuing the same in good faith; (3) warrants in writing its good faith intent to commence offering local exchange service in the relevant Directory coverage area (except as otherwise provided in Exhibit C herein)

en

for no less than five months of the effective Directory service period; (4) warrants in writing that it shall notify BAPCO when CARRIER actually commences provision of local exchange service in the Directory service area; (5) warrants in writing that all CARRIER telephone numbers listed will be answered by service representatives during normal business hours during the Directory service period. BAPCO agrees as follows:

(a) BAPCO shall include at no charge to CARRIER or CARRIER's subscribers one standard listing for each CARRIER subscriber per hunting group in BAPCO's appropriate local alphabetical Directory as published periodically by BAPCO unless notified or nonpublished status is designated by subscribers. Such listings shall be interfiled with the listings of other local exchange telephone company subscribers and otherwise published in the manner of such other listings in accordance with and subject to BAPCO's generally applicable publishing policies and standards without designation or differentiation as to the subscriber's exchange carrier.

(b) BAPCO shall publish additional listings, foreign listings and all other alphabetical Directory listings offered by BellSouth for CARRIER subscribers upon their request, consistent with BAPCO's generally applicable policies in BAPCO's alphabetical Directories. BAPCO shall publish all listings for all carriers' subscribers in an identical manner and upon the same terms, conditions and applicable policies.

(c) BAPCO will distribute its regularly published alphabetical and classified Directories to local CARRIER subscribers in accordance with BAPCO's prevailing practices, including delivery following Directory publication and upon establishment of new CARRIER service, if a current Directory for that geographic area has not previously been provided. Such deliveries may include separate advertising materials accompanying the Directories.

(d) Except as otherwise provided herein, BAPCO will include for CARRIER, in the same manner as that included for all other carriers, information relating to establishment of service, repair and billing in the generic customer guide pages of its alphabetical Directories in accordance with BAPCO's prevailing standards for the same. BAPCO shall not include any carrier logos in CARRIER's generic customer guide pages; provided, however, that CARRIER shall have the option of including its own logo in such pages in the event that BAPCO allows any other carrier to include its logo in the generic customer guide pages. CARRIER will provide information requested by BAPCO for such purpose on a timely basis.

(e) BAPCO shall make available at no charge to CARRIER or its subscribers one listing for CARRIER business customers per hunting group in one appropriate heading in BAPCO's appropriate local classified directory as published periodically by BAPCO. Such listings shall be published according to BAPCO's generally applicable publishing policies and standards.

en

BAPCO shall solicit accept and publish directory advertising from subscribers of CARLEER in communities for which BAPCO publishes a list. Directories in the same matter and upon the same terms as it solicits, accepts and publishes advertising from advertisers who are not CARLEER subscribers. Except for subscriber information actually published in a Directory, BAPCO shall not use any subscriber information provided to it by CARLEER, for the solicitation of business for other carriers.

(7) BAPCO shall not provide listing information relating to CARLEER subscribers to other local exchange service providers or independent directory publishers without CARLEER approval, except as may be required in relation to this Agreement or as otherwise required by law.

4. STATISTICAL POLICIES BAPCO shall maintain full authority over its publishing schedules, policies, standards and practices and over the scope and publication of its Directories. BAPCO shall periodically provide CARLEER with changes by BAPCO in the same which in BAPCO's judgment affect CARLEER's conduct in BAPCO's publishing of listings for CARLEER's subscribers. Such policy updates shall include, without limitation, the subject described in Exhibit C.

LIABILITY AND INDEMNITY

(8) CARLEER agrees to defend, indemnify and hold harmless BAPCO from all damages, claims, suits, losses or expenses, including without limitation reasonable costs and attorney's fees, arising out of or resulting from any error in or omission of any residential or business listing for subscribers of CARLEER to the extent such error or omission is caused by CARLEER's failure to provide accurate subscriber information to BAPCO.

(9) BAPCO agrees to defend, indemnify and hold harmless AT&T from all damages, claims, suits, losses or expenses, including without limitation reasonable costs and attorney's fees, arising out of or resulting from: (i) any error in or omission of any paid advertising for subscribers of CARLEER other than those errors caused by CARLEER's failure to provide accurate subscriber information to BAPCO; provided, however, that BAPCO agrees that, where permitted by law, its advertising contract with CARLEER's subscribers shall limit liability of BAPCO and CARLEER for errors and omissions to a return of advertising charges for the advertising occupying the error or omission (including of such listings of CARLEER's liability to be undertaken in BAPCO's normal course of business); or (ii) any error in or omission of any business listing for subscribers of CARLEER to the extent such error or omission is caused by BAPCO's failure to publish correctly such subscriber information provided by CARLEER. provided, however, that notwithstanding the foregoing, BAPCO's liability for any errors relating to or arising from errors in or omissions of residential subscriber listings shall be limited to One Dollar (\$1.00) for each such claim.

(c) Except as provided above, each party agrees to defend, indemnify and hold harmless the other from all damages, claims, suits, losses or expenses, including without limitation reasonable costs and reasonable attorney's fees, to the extent of such party's relative fault, arising out of or resulting from any error, omission or act of such party hereunder. Each party shall notify in writing the other promptly of any act or omission which may give rise to a claim hereunder, and of any claim or suit arising hereunder. Each party shall provide reasonable and timely cooperation in its resolution any claim or lawsuit arising hereunder. Without waiver of any rights hereunder, the indemnified party may at its expense undertake its own defense in any such claim or suit.

(d) Notwithstanding anything in this Section 5 to the contrary, in no event shall either party be liable to the other or to any third party for any special, incidental or consequential damages or any loss of profits.

(e) CARRIER agrees to include in any local service tariff it files a provision limiting its liability and that of BAPCO, for any claims relating to directory listings or advertisements, to the subscribers' cost of local service or to the charge for any such listing, whichever is less.

6. TERM. This Agreement shall be effective on the date of the last signature hereof for a term of two (2) years and shall relate to Directories published by BAPCO during such period. Thereafter, it shall continue in effect unless terminated by either party upon sixty days prior written notice.

7. ASSIGNMENT. This Agreement shall be binding upon any successors or assigns of the parties during its Term.

8. RELATIONSHIP OF THE PARTIES. This Agreement does not create any joint venture, partnership or employment relationship between the parties or their employees, and the relationship between the parties shall be that of an independent contractor. There shall be no intended third party beneficiaries to this Agreement.

9. NONDISCLOSURE.

(a) During the term of this Agreement it may be necessary for the parties to provide each other with certain information ("information") considered to be private or proprietary. The recipient shall protect such information from distribution, disclosure or dissemination to anyone except its employees or contractors with a need to know such information in conjunction herewith, except as otherwise authorized in writing. All such information shall be in writing or other tangible form and clearly marked with a confidential or proprietary legend. Information conveyed orally shall be designated as proprietary or confidential at the time of such oral conveyance and shall be reduced to writing within forty-five (45) days.

LB



b) The parties will not have an obligation to protect any portion of information which: (1) is made publicly available lawfully by a company to this Agreement; (2) is lawfully obtained from any source other than the providing party; (3) is previously known without an obligation to keep it confidential; (4) is released by providing party in writing; or (5) commencing two (2) years after the termination of this Agreement if such information is not a trade secret under applicable law.

c) Each party will make copies of the information only as necessary for its use under the terms hereof, and each such copy will be marked with the same proper notices as appear on the originals. Each party agrees to use the information solely in support of this Agreement and for no other purpose.

10. **FORCE MAJEURE.** Neither party shall be responsible to the other for any delay or failure to perform hereunder to the extent caused by fire, flood, explosion, war, strike, riot, embargo, governmental requirements, civic or military authority, act of God, or of similar cause beyond its reasonable control. Each party shall use best efforts to notify the other promptly of any such delay or failure and shall provide reasonable cooperation to ameliorate the effects thereof.

11. **PUBLICITY.** Neither party shall disclose the terms of this Agreement nor use trade names or trademarks of the other without the prior express written consent of the other.

12. **REPRESENTATIVES AND NOTICES.**

(a) Each party shall name one or more representatives for contacts between the parties which shall be authorized to act on its behalf. Such representatives may be changed from time to time upon written notice to the other party.

(b) Notices required by law or under this Agreement shall be given in writing by hand delivery, certified or registered mail, or by facsimile followed by certified or registered mail, addressed to the named representatives of the parties with copies to:

IF to BAPCO:

Director-LEC/BST Interface  
BellSouth Advertising & Publishing Corporation  
Room 270  
59 Executive Park South  
Atlanta, GA 30329

With Copy to: Vice President and General Counsel  
BellSouth Advertising & Publishing Corporation  
Room 430  
59 Executive Park South  
Atlanta, GA 30329

If to CARRIER: Bill White  
1200 Peachtree Street, NE  
Atlanta, GA 30309

With Copy to: Norman H. Rosner  
Senior Attorney  
1200 Peachtree St., NE  
Room 4080  
Atlanta, GA 30309

13. **BINDING NATURE.** AT&T agrees to provide a letter substantially in the form attached as Exhibit "D" to all regulatory or legal bodies in which it has filed requests for arbitration or other action concerning directory issues affecting BAPCO.

14. **MISCELLANEOUS.** This Agreement represents the entire Agreement between the parties with respect to the subject matter hereof and supersedes any previous oral or written communications, representations, understandings, or agreements with respect thereto. It may be executed in counterparts, each of which shall be deemed an original. All prior and contemporaneous written or oral agreements, representations, warranties, statements, negotiations, and /or understandings by and between the parties, whether express or implied, are superseded, and there are no representations or warranties, either oral or written, express or implied, not herein contained. This Agreement shall be governed by the laws of the state of Georgia.

IN WITNESS WHEREOF, the parties have executed this Agreement by their duly authorized representatives in one or more counterparts, each of which shall constitute an original, on the dates set forth below.

**BELLSOUTH ADVERTISING & PUBLISHING CORPORATION**

By: [Signature]

Title: Executive Vice President

Date: 8/14/96

**AT&T CORP**

By: [Signature]

Title: VICE PRESIDENT

Date: 8/14/96

*[Handwritten initials]*

EXHIBIT A

ACCOUNT INFORMATION SECTION (Items in this section are mandatory)

- 1. **Main Telephone Number** Main line of telephone service that all other numbers are associated to: (Area Code/XXLine Numbers)
- 2. **Published Telephone Number** Telephone number to appear in the directory
- 3. **Old Telephone Number** (If the number is changing, enter the OLD Telephone Number)
- 4. **Type of Directory Service:** Bus (Business) or Res (Residence)
- 5. **Order Type:** N - New connect order, D - Disconnect service order, C - Change of listing
- 6. **Due Date:** Date that service is requested.
- 7. **Carrier Name:** The name of the local exchange carrier and operating company code
- 8. **Carrier Number:** Operating Company Number

PRIMARY LISTING INFORMATION SECTION (Items in this section are mandatory)

- 9. **Listed Name:** The way the listing is to appear in the directory. (maximum 1,000 character including spaces) Custom arrangements should be forwarded per guidelines. Non-Pub or Non-List situations should be indicated.
- 10. **Listed Address:** Current address may include street number - street name, city, state, and code. (Note: P.O. Box or Route not acceptable). Outside address shown as (OAD).
- 11. **Service Address:** Physical location of the telephone.
- 12. **Community Name:** The name of the community where the listing appears. (i.e., the Area)
- 13. **Zip code:** 5 or 9 character code.
- 14. **Yellow Pages Heading:** The Yellow Pages heading where customer wants his listing to appear. (Valid for Business Primary Listings only)
- 15. **Directory Name:** Name of the directory where customer desires listing to appear (includes down section if applicable). (If consistent with existing central office and directory configuration, listing will be included. If different, a Foreign Listing will be charged. Directory appearance needed this is based on the central office prefix. Exchanges for appearance in other directories will be at the rate of a Foreign Listing (FL).

BILLING INFORMATION SECTION (Items in this section are required per optional)

- 16. **Billing Name to appear on bill**
- 17. **Billing Address:** Street number, street name, city, state, zip.
- 18. **Current Telephone Number:** Telephone number to contact regarding billing.
- 19. **Alternate Billing:** Owner's name or partner's name or 2 corporate offices.
- 20. **Type of Ownership:** Sole owner, Partnership or Corporation.
- 21. **Tax ID Number or Social Security Number:** If sole owner, must have social security number.

DIRECTORY DELIVERY INFORMATION SECTION (Items in this section are mandatory)

- 22. **Name:** Personal or business name.
- 23. **Delivery Address:** Street number, street name, city, state, zip code of where director is to be delivered.

er

- 24. Directory (Book ID): Bolt code of the directory
- 25. Number of books back: for immediate delivery replacement
- 26. Number of books annually: 0 - 3 residence, 0 - 5 business, then negotiated.

**REMARKS SECTION (As required)**

- 27. Remarks: Free flow field used by Carrier for any additional information

**PRIVATE/PROPRIETARY**

Contains private and/or proprietary information. May not be used or disclosed outside the BeeSouth companies without purchase of a written agreement.

*MD*

BAPCO Deliverables

Publication Schedules

BAPCO will provide to all carriers a printed copy of the publication schedules for all directories within the area served by the carrier. This schedule will include the name of the directory, the directory bolt code, the business office close date and the issue date. The business office close date represents the last day to receive activity for appearance in the subsequent directory. This date also represents the close date for advertising activity into the Yellow Pages.

The issue date represents the mid-point of delivery of the new directory and the date at which new directory billing will begin for the directory being delivered. The length of the delivery period will vary depending upon the size of directory.

Yellow Pages Headings

BAPCO will provide a printed version of the Yellow Pages Heading file which will include all Yellow Pages headings allowed by BAPCO, the Yellow Pages heading code and the associated SIC code. This material would be utilized to assist the business customer in identifying where they would like representation in BAPCO's classified Yellow Pages directories.

Coverage Maps

BAPCO will provide a coverage map for its major directories identifying broadly the geographic area served by the major directory. These maps will be provided only for the major directories in the area served by the carrier.

Central Office Table

BAPCO will provide two printed versions of what is called the ABC table. Version 1 of this report, identifies by NPA and in sequence by central office in which directory a customer is entitled to appear. Version 2 of this report reflects the directory name and all central offices appearing within that directory.

Listing Specifications

BAPCO will provide a condensed printed version of listing specifications reflecting the rules and regulations regarding listing appearance in both the white and yellow pages.

*MB*

Abbreviations Table

BAPCO will provide a printed copy of the standard abbreviations utilized for given names, titles of address, titles of lineage, military titles, degrees and professional affiliations standards. This information can be used to assist in effectively processing various listed name requests.

Foreign Directory Name Table

BAPCO will provide a list of all foreign directory names to be used in the processing of foreign listing requests. This field is a required element in the establishment of foreign listings.

Customer Guide Page Appearance Procedures

BAPCO will provide free listing appearance under the areas of Establishing Service, Billing and Repair in the Customer Guide Section of the White Pages for directories where a carrier operates. These procedures identify how to get your listing to appear and procedures for purchasing LEC specific pages.

The parties acknowledge and agree that for the Directory coverage areas listed below, CARRIER shall warrant to BAPCO in writing its good faith intent to commence offering local exchange service in such Directory coverage areas for no less than three (3) months of the effective Directory service period:

(LIST AREAS)

MB

AT&T LETTER TO PSC'S

Dear \_\_\_\_\_

*File*

This is to advise that AT&T has reached agreement with BellSouth Advertising & Publishing Corporation ("BAPCO") concerning any and all directory issues raised in our previous filings requesting arbitration by the Commission (Authority in Tennessee) other than AT&T's right to place its name on the cover of directories published by BAPCO on the same terms and conditions and in the same size and format as that of BellSouth Communications, Inc. We withdraw all other directory issues from the prior requests submitted to the Commission.

cc: BAPCO

*MB*



## BONA FIDE REQUEST PROCESS

- 1 Bona Fide Requests are to be used when AT&T requests a change to any Services and Elements provided hereunder, including features, capabilities, or functionality.
  - 1.1 A Bona Fide Request shall be submitted in writing by AT&T and shall specifically identify the required service date, technical requirements, space requirements and/or such specifications that clearly define the request such that BellSouth has sufficient information to analyze and prepare a response. Such a request also shall include AT&T's designation of the request as being (i) pursuant to the Telecommunications Act of 1996 or (ii) pursuant to the needs of the business.
  - 1.2 Although not expected to do so, AT&T may cancel, without penalty, a Bona Fide Request in writing at any time. BellSouth will then cease analysis of the request.
  - 1.3 Within two (2) business days of its receipt, BellSouth shall acknowledge in writing, the receipt of the Bona Fide Request and identify a single point of contact and any additional information needed to process the request.
  - 1.4 Except under extraordinary circumstances, within thirty (30) days of its receipt of a Bona Fide Request, BellSouth shall provide to AT&T a preliminary analysis of the Bona Fide Request. The preliminary analysis will include BellSouth's proposed price (plus or minus 25 percent) and state whether BellSouth can meet AT&T's requirements, the requested availability date, or, if BellSouth cannot meet such date, provide an alternative proposed date together with a detailed explanation as to why BellSouth is not able to meet AT&T's requested availability date. BellSouth also shall indicate in this analysis its agreement or disagreement with AT&T's designation of the request as being pursuant to the Act or pursuant to the needs of the business. If BellSouth does not agree with AT&T's designation, it may utilize the Disputes Resolution Process provided in Attachment 1 of this Agreement. In no event, however, shall any such dispute delay BellSouth's processing of the request. If BellSouth determines that it is not able to provide AT&T with a preliminary analysis with thirty (30) days of BellSouth's receipt of a Bona Fide Request, BellSouth will inform AT&T as soon as practicable. AT&T and BellSouth will then determine a mutually agreeable date for receipt of the preliminary analysis.

*LB*

- 1.5 As soon as possible, but in no event more than ninety (90) days after receipt of the request, BellSouth shall provide AT&T with a firm Bona Fide Request quote which will include, at a minimum, the firm availability date, the applicable rates and the installation intervals, and a binding price quote.
- 1.6 Unless AT&T agrees otherwise, all proposed prices shall be the pricing principles of this Agreement, in accordance with the Act, and any applicable FCC and Commission rules and regulations. Payments for services purchased under a Bona Fide Request will be made as specified in this Agreement, unless otherwise agreed to by AT&T.
- 1.7 Within thirty (30) days after receiving the firm Bona Fide Request quote from BellSouth, AT&T will notify BellSouth in writing of its acceptance or rejection of BellSouth's proposal. If at any time an agreement cannot be reached as to the terms and conditions or price of the request, or if BellSouth responds that it cannot or will not offer the requested item in the Bona Fide Request and AT&T deems the item essential to its business operations, and deems BellSouth's position to be inconsistent with the Act, FCC or Commission regulations and/or the requirements of this Agreement, the Dispute Resolution Process set forth in Appendix I of the Agreement may be used by either Party to reach a resolution.

**INTERFACE REQUIREMENTS FOR ORDERING AND PROVISIONING,  
MAINTENANCE AND REPAIR AND PRE-ORDERING**

**1 Purpose**

1.1 This Attachment 15 sets forth the interface requirements for ordering and provisioning, maintenance and repair and pre-ordering, where AT&T provides service to its customers through resale of Local Services or through the use of unbundled Network Elements and Combinations

1.2 For all Local Services, Network Elements and Combinations ordered under this Agreement, BellSouth will provide AT&T and its customers ordering and provisioning, maintenance, and repair and pre-ordering services within the same level and quality of service available to BellSouth, its Affiliates, and its customers.

1.3 **DELETED**

**2. Use of Standards**

2.1 As described below, AT&T and BellSouth agree to implement each interface based upon existing and evolving industry standards. The Parties shall transition the electronic interfaces to industry standards as those standards become available.

2.2 **DELETED**

**3. Reimbursement**

3.1 Reimbursement for operational interfaces shall be as determined by the appropriate regulatory agency as set forth in Part IV.

**4. Interim Interfaces**

4.1 The Parties have agreed upon certain interim interfaces to support Local Services, Network Elements and Combinations including:

- Ordering and Provisioning
- Maintenance and Repair
- Pre-Ordering
  - Address Validation
  - Service Feature Availability
  - Telephone Number Assignment
  - Appointment Scheduling
  - Customer Service Record Requests



4.2 The interim interfaces for Ordering and Provisioning for Local Services includes a jointly developed Phase 1 Electronic Data Interchange (EDI) interface operating over a value added network provider communications linkage. For BellSouth's Phase 2 EDI interface and for subsequent interim EDI implementations, AT&T agrees to use BellSouth's defined EDI interim interface. BellSouth agrees to share information regarding Phase 2 EDI interfaces, solicit AT&T's comments, and as appropriate incorporate such comments into subsequent joint testing and implementation of the interface. BellSouth is engaged in the integration of this EDI feed into a Mechanized Service Order Generation System. Errors, rejects, jeopardy notices, and in-process provisioning status reports are provided through a combination of telephone calls and facsimile exchanges.

4.3 For Loop and Transport Unbundled Network Elements, the interim interfaces utilize BellSouth's Access Service Request (ASR) process with manual intervention as required, including the ordering of:

- CCS-SS7 Signaling Connections/Access Links
- Line Information DataBase (LIDB) - Validation Service
- 800 Access Ten Digit Screening
- Local Interconnection/Trunking Arrangements
- Operator Services - Directory Assistance and Toll & Assistance
- Unbundled Exchange Access Loop

4.4 The interim interfaces for Maintenance and Repair include:

- a) telephonic exchanges between AT&T and BellSouth maintenance and repair work center personnel; and
- b) the use of BellSouth's TAFI interface for Plain Old Telephone Service (POTS) when available.

These will be used to accomplish the functions desired to be obtainable over the interface described in Section 5 following.

4.5 The interim interfaces for Pre-Ordering are as follows:

**Address Validation** - on-line Local Area Network to Local Area Network connectivity to BellSouth's Regional Street Address Guide.

**Service/Feature Availability** - file transfer download of BellSouth's Products/Services Inventory Management System files via the Network Data Mover Network using Connect:direct.

*MB*

Telephone Number Assignment - request for and file transfer download of blocks of numbers reserved for AT&T's use via the Network Data Mover Network using Connect: direct.

Appointment Scheduling - paper standard interval guidelines.

Customer Service Record Requests - three way call between customer, AT&T service representative, and BellSouth Local Service Center representative, or facsimile exchange of customer's Letter of Agency.

- 4.5.1 AT&T acknowledges that BellSouth is developing additional interim interfaces that provide the capability to perform Pre-Ordering via an electronic interface using web technology. AT&T reserves the right to review specifications for such interfaces as they become available, and the right to elect to use any such interface it deems operationally and economically viable.
- 4.6 BellSouth and AT&T agree to work together to develop and implement an electronic communication interface that will replace these interim interfaces with the electronic interfaces described below. For purposes of this Attachment electronic communication interface defines a machine-to-machine or application-to-application interface and excludes an interface that provides a presentation for manual entry. As described below in Section 9, the Parties will establish a project plan and a Joint Implementation Agreement for each interface. Such project plan and Joint Implementation Agreement will be based upon industry standards and, where necessary, mutually agreeable supplemental specifications substantially defined by March 1, 1997. Change control procedures will be established to provide for consideration of enhancements to standards which become available during the development cycle for an interface. The Parties agree to use best efforts to implement the interfaces described below no later than December 31, 1997, unless a later date is mutually agreed upon by the Parties.
- 4.7 The Parties further agree to work collaboratively within the industry to establish and conform to uniform industry standards for electronic interfaces for ordering and provisioning, maintenance and repair and pre-ordering. Neither Party waives any of its rights as participants in industry forums in the implementation of the standards.

## 5. Electronic Interfaces for Ordering and Provisioning

### 5.1 Local Service Resale



- 5.1.1 The exchange of information relating to the ordering and provisioning of Local Service, when AT&T is the customer of record for the resold service(s), will be based upon the most current interpretations of the American National Standards Institute (ANSI) Accredited Standards Committee (ASC) X12 Standards as documented by the Service Order Subcommittee (SOSC) of the Telecommunications Industry Forum/Electronic Data Interchange (TCIF/EDI) committee. The most current version of the SOSC implementation guideline for EDI is version 6
- 5.1.2 The information exchange will be forms-based, using Local Service Request (LSR) Form, End User Information Form, and the Resale Service Form developed by the OBF. The SOSC interpretations of the 850, 860, 855, 864, 865, and 997 transactions, in accordance with the OBF forms, will be used to convey, when available and where applicable, all the necessary data to connect, modify or disconnect Local Services of BellSouth that AT&T resells, including the capability to establish directory listings and perform service suspension, denial and restoral. In the absence of SOSC interpretations of the 850, 860, 855, 864, 854, and 997 transactions, both Parties agree to use the defined EDI mappings for Phase 1 and Phase 2.
- 5.1.3 If the EDI translator of BellSouth detects a syntax error(s), BellSouth will reject the order using the 997 transaction, identifying the type of syntax error(s) and indicate to AT&T that the entire order must be resubmitted. If BellSouth detects that agreed upon data is missing or incorrect, subsequent to the EDI translator processing, BellSouth will reject the AT&T order and indicate the need for AT&T to resubmit the order. BellSouth agrees to develop an acceptable X.12 EDI transaction type for identifying and advising AT&T of missing or incorrect data.
- 5.1.4 AT&T and BellSouth will use an X.400 message standard, until it is replaced with a transaction-based protocol, and a mutually agreeable X.25 or TCP/IP based transport network for exchange of transactions. AT&T and BellSouth will translate ordering and provisioning requests originating in their internal processes into the agreed upon forms and EDI transactions.
- 5.1.5 Both Parties agree to complete the defined translations, establish a query-response cycle time commitment, including but not limited to order rejection and firm order confirmation, and proceed to systems readiness testing, as more fully described in Section 7, that will result in a fully operational interface for resale of Local Service by March 31, 1997.

MB

FL6/10/97

- 5.1.6 AT&T and BellSouth agree to adapt the interface based on evolving standards. To the extent changes to SOSC implementation guidelines affect local service ordering, the Parties agree to use best efforts to implement such changes, including testing of changes introduced, within 7 months of the publication date of the TCIF/SOSC guidelines. This preceding target implementation obligation may be modified by mutual agreement.
- 5.2 Unbundled Network Elements
- 5.2.1 AT&T and BellSouth will use two types of orders, an infrastructure Provisioning order and a Customer Specific Provisioning order, to establish local service capabilities based upon Unbundled Network Element architecture. The Infrastructure Provisioning order notifies BellSouth of the common use Network Elements and Combinations that AT&T will require. For services covered in BellSouth's "OLEC-to BellSouth Facility-Based" guide, this notification will occur through use of an ASR. BellSouth will make periodic updates to the OLEC guide to reflect UNEs that are found to be technically feasible by the appropriate regulatory agency. For services not covered in BellSouth's "OLEC-to-BellSouth Facility-Based" guide, this notification will occur through use of an Infrastructure Footprint Form. The Infrastructure Footprint Form, when applicable, and the associated ASR forms (Local Switching, Interoffice Transport, Signaling and Database, Operator Services and DA) order the Network Elements and Combinations used in common (across AT&T retail customers) and identify the geographic area AT&T expects to serve through the Network Elements and Combinations ordered. AT&T and BellSouth may mutually agree to use an alternative format for exchange of Footprint Order related information, provided that the same information content is delivered.
- 5.2.2 For services not covered in BellSouth's "OLEC-to-BellSouth Facility-Based" guide, BellSouth will accept the Infrastructure/Footprint Form developed by AT&T, or the mutually agreed upon equivalent format, until such time AT&T and BellSouth agree that the OBF has adopted an acceptable alternative form. In addition, BellSouth will accept a modified version of the OBF Translation Questionnaire (TQ) Form. The modified TQ will be sent to BellSouth when BellSouth must modify the routing tables for its end offices to accommodate the treatment of customer calling associated with the combination of Network Elements that AT&T is employing to deliver service. AT&T will provide the Infrastructure/Footprint Form and all associated ASR forms.
- 5.2.3 When applicable, BellSouth will accept delivery of the Infrastructure Footprint Form and the modified TQ through the ASR process, including 

passing of the information over a file transfer network (e.g., Network Data Mover Network) using the CONNECT direct file transfer product unless another mutually agreeable exchange mechanism is established.

- 5.2.4 AT&T and BellSouth agree to adapt the interface based upon evolving standards. Changes to OBF ASR forms and implementation guidelines, to the extent relevant to ordering and provisioning for Local Services, will be implemented based upon industry standard implementation schedules as set by the Telecommunications Service ordering Committee of OBF. This preceding target implementation obligation may be modified by mutual agreement.
- 5.2.5 When applicable, the Customer Specific Provisioning order will be based upon OBF LSR forms. The applicable SOSC implementation guidelines described in the prior paragraphs relating to resale of BellSouth retail services also apply to the Customer Specific Provisioning orders.
- 5.2.5.1 Unbundled loops are an exception to Section 5.2.5 above. Currently, BellSouth accepts an ASR form for the ordering of unbundled loops. BellSouth will use best efforts to adopt the LSR as the ordering document within 7 months of the published release of the TCIF/SOSC standard for ordering unbundled loops via EDI.
- 5.2.6 When applicable, BellSouth agrees that the information exchange will be forms-based using the Local Service Request Form, End User Information Form, Loop Service Form (which may ultimately be renamed the Loop Element form) and Port Form (which may ultimately be renamed the Switch Element Form) developed by the OBF. The SOSC interpretation of 850, 860, 855, 864, 865, and 997 transactions, in accordance with the OBF forms, will be used to convey all the necessary data to connect, modify or disconnect BellSouth's customer-specific UNEs employed by AT&T to deliver Local Services. Unless the Parties otherwise agree, all EDI-based transactions for ordering BellSouth's customer-specific UNEs will occur over the interface utilized by AT&T ordering Local Service for resale. Errors and rejections of orders will be treated as described in the paragraphs relating to resale of BellSouth Local Services. Customer-specific elements include, but are not limited to, the customer loop, the network interface device, the customer-dedicated portion of the local switch and any combination thereof.
- 5.2.7 AT&T and BellSouth will use an X.400 message standard, until it is replaced by a transaction-based protocol, and a mutually agreeable X.25 or TCP/IP based network to exchange requests. AT&T and BellSouth will translate ordering and provisioning requests originating in their internal



processes into the agreed upon forms and EDI transactions. Both Parties agree to complete the defined translations, establish a query-response cycle time commitment, including but not limited to order rejection and firm order confirmation, and proceed to systems readiness testing, as more fully described in Section 8, that will result in an operational interface for ordering UNEs by December 31, 1997. AT&T and BellSouth agree to adapt the interface based upon evolving standards. To the extent changes to SOSC implementation guidelines affect local service ordering and provisioning for customer specific unbundled Network Elements and Combinations, the Parties agree to use best efforts to implement such changes, including testing of changes introduced, within 7 months of the publication date of the TCIF/SOSC guidelines. This preceding target implementation obligation may be modified by mutual agreement.

5.3 Treatment of 860 Messages

- 5.3.1 BellSouth will accept an 860 transaction that contains the complete refresh of the previously provided order information (under the original 850 transaction) simultaneously with the supplemental (new/revised) information from AT&T. This treatment with respect to the 860 transaction will be accepted by both Parties until the SOSC explicitly clarifies the information exchanges associated with supplementing orders or AT&T and BellSouth mutually agreed to change the treatment. AT&T and BellSouth will agree upon a mutually acceptable time frame for adapting their internal systems to accommodate any alteration to treatment of the 860 message described in this paragraph. In no event will the time frame for adaptation extend more than one year past the date the SOSC initiated change or AT&T and BellSouth agreeing to modify the treatment of 860 messages.

6. Electronic Interfaces for Maintenance and Repair

- 6.1 Maintenance and repair information exchange will be transmitted over the same interface according to the same content definition both for resold BellSouth retail Local Services and for services AT&T provides using a Network Elements or Combinations.
- 6.2 When technically feasible, AT&T and BellSouth will, for the purpose of exchanging fault management information, establish an electronic bonding interface, based upon ANSI standards T1.227-1995 and T1.228-1995, and Electronic Communication Implementation Committee (ECIC) Trouble Report Format Definition (TRFD) Number 1 as defined in ECIC document ECIC/TRA/95-003, and all standards referenced within those documents. The Parties acknowledge that the present version of these standards supports different functions for different Network elements. Where a

function is not presently supported for a given Network Element, the Parties agree to work collaboratively within the industry for its inclusion in future releases of the standards. The Parties will use and acknowledge functions currently implemented for reporting access circuit troubles. These functions include Enter Trouble, Request Trouble Report Status, Add Trouble Information, Modify Trouble Report Attributes, Trouble Report Attribute Value Change Notification and Cancel Trouble Report, all of which are fully explained in clauses 6 and 9 of ANSI T1.228-1995.

- 6.3 AT&T and BellSouth will exchange requests over a mutually agreeable X.25 based network or if mutually agreeable, a TCP/IP based network may be employed. AT&T and BellSouth will translate maintenance requests or responses originating in their internal processes into the agreed upon attributes and elements. Both Parties agree to complete the defined translations, and proceed to systems readiness testing that will result in an operational interface for local service delivery by the date set forth in Section 4.6 above upon delivery of the mutually agreed upon requirements. AT&T and BellSouth agree to adapt the interface based upon evolving standards. To the extent changes to NOF, ECIC or T1M1 standards affect the maintenance and repair functionality for Local Services, the Parties agree to use best efforts to implement such changes, including testing of changes introduced, within 7 months, but not longer than 9 months, of the publication of the standard by the relevant ATIS committee or subcommittee. This preceding target implementation obligation may be modified by mutual agreement.

## 7. Electronic Interfaces for Preordering

### 7.1 Transaction-Based Information Exchange

- 7.1.1 When applicable, the Parties agree that preordering information exchange, as defined in Section 4.5 preceding, will be transmitted over the same interface according to the same content definition both for resold BellSouth telecommunications services and for services provided using Network Elements and Combinations. BellSouth shall expeditiously develop and deploy an on-line electronic means for AT&T to receive customer service records on a restricted basis that will appropriately safeguard a customer's privacy. This electronic interface must meet AT&T's needs and also contain such safety provisions or restrictions to make sure that it safeguards customer privacy in an appropriate manner. AT&T shall not be required to present prior written authorization from each customer to BellSouth before BellSouth allows access to Customer Service Records. AT&T shall issue a blanket letter of authorization to BellSouth which states that AT&T will obtain the customer's permission before accessing

Customer Service records. BellSouth and AT&T agree to develop an interface which will insure protection of customer privacy by discouraging roaming through customer information and that only provides the Customer Service Record necessary to provide telecommunications services.

- 7.1.2 AT&T and BellSouth will establish a transaction-based electronic communications interface according to the AT&T proposed data model for preordering which is based upon the most current version of the SOSC implementation guideline for EDI which is version six (6). Unless BellSouth and AT&T agree to an alternative exchange mechanism by April 1, 1997, then an exchange protocol based upon a subset of CMIP transactions, referred to as EC-Lite, will be used to transport EDI formatted content necessary to perform inquiries for Switch/Feature Availability (on an exception basis when batch feed data is incomplete), Address Verification (on an exception basis when batch feed data is incomplete), Telephone Number Assignment, Appointment Scheduling, and Customer Service Records. AT&T and BellSouth will exchange transactions over a mutually agreeable X.25 or TCP/IP based network.
- 7.1.3 AT&T and BellSouth will translate preordering data elements used in their internal processes into the agreed upon forms and EDI. Both Parties will complete the defined translations, establish query-response cycle time commitments, including but not limited to notification of message acknowledgments and message rejections, and proceed to systems readiness testing, as covered in more detail in Section 8, that will result in a fully operational interface for local service delivery. The implementation date for this interface will be as stated in Section 4.6. This preceding target implementation obligation may be modified by mutual consent.
- 7.1.4 AT&T and BellSouth agree to adapt the interface based upon evolving standards. To the extent changes to OBF or SOSC EDI implementation guideline related to preordering functionality, the Parties agree to use best efforts to implement such changes, including testing of the changes introduced within 7 months of the date of published electronic interface standards by the relevant ATIS committee or subcommittee. This preceding target implementation obligation may be modified by mutual agreement.

## 7.2 Batch Data Information Exchange

- 7.2.1 BellSouth will accept AT&T's request for initial batch feeds of Service/Feature Availability and Regional Street Address Guide (or an equivalent). At a minimum, this batch feed will include the switch/feature

availability, information and address information currently provided via the interim interface described in Section 4.5 above.

- 7.2.2 AT&T and BellSouth will establish a mutually agreeable format for the exchange of batch data no later than 90 days following adoption of this agreement. When the interface is operational, BellSouth will transmit the initial batch feed of the data, relating to the geographic area specified by AT&T pursuant to a mutually agreed upon schedule. In addition, BellSouth will provide complete refreshes of the data, for the geographic areas cumulatively encompassed by requests from AT&T, on a mutually agreeable monthly schedule. BellSouth will send the initial batch feed and subsequent monthly updates electronically via a file transfer network (e.g., Network Data Mover Network) using the CONNECT:Direct file transfer product.
- 7.2.3 AT&T and BellSouth will translate necessary data elements used in their internal processes into mutually agreeable and consistent file formats and record layouts. Both Parties agree to complete development and proceed to systems readiness testing that will result in an operational interface by December 31, 1997. To the extent that an industry forum, committee or subcommittee, under the auspices of ATIS, establishes guidelines and/or standard relating to the batch information data described above, the Parties agree to use best efforts to implement such changes, including testing of the changes introduced, within 7 months of the publication of the standard by the relevant ATIS committee or subcommittee. This preceding target implementation obligation may be modified by mutual agreement.

## 8. Testing and Acceptance

- 8.1 AT&T and BellSouth agree that no interface will be considered as operational until end-to-end integrity and load testing, as agreed to in the Joint Implementation Agreement (Section 9), or other mutually acceptable documentation is completed to the satisfaction of both Parties. The intent of the end-to-end integrity testing is to establish, through the submission and processing of test cases, that transactions agreed to by AT&T and BellSouth will successfully process, in a timely and accurate manner, through both Parties' supporting OSS as well as the interfaces. For transaction-based interfaces, the testing will include the use of mutually agreeable test transactions, designed to represent no less than 85% of the transaction types that AT&T expects to send and receive through the interface undergoing end-to-end testing.
- 8.2 In addition, AT&T and BellSouth will establish either a mutually agreeable testing environment or alternative method, such as an audit process,

sufficient to demonstrate that the interfaces established between AT&T and BellSouth have the capability and capacity to exchange busy period transaction volumes reasonably projected to occur during the forward-looking twelve month period following implementation of the interface. This process must validate that AT&T and BellSouth can accept and process the anticipated busy period load without degradation of overall end-to-end performance of the information exchange even when other CLEC transactions are simultaneously processed by BellSouth.

- 8.3 It is understood by the Parties that End-to-End testing and load testing are necessary processes in the implementation of electronic interfaces and in establishing what further work needs to be done to insure that AT&T will receive electronic interfaces at parity with what BellSouth provides itself, its Affiliates, and its customers. In no instance will End-to-End testing or load testing processes be short-cut, expedited, or in any other way jeopardized such that the quality of the production implementation is put at risk. It is understood by the Parties that such testing occurs immediately preceding production implementation of electronic interfaces and that in the event of delays by either party End-to-End testing and load testing will not be expedited solely to meet the time frames outlined in this agreement. This implementation obligation may be modified by mutual agreement.
- 8.4 The results of testing will not be shared with other parties without the written consent of AT&T and BellSouth.

#### 9. Joint Implementation Agreement Development

- 9.1 AT&T and BellSouth agree to document, within 60 days of approval of this Agreement, a project plan for each interface that explicitly identifies all essential activities, sequence and interrelationship of these activities and the target completion dates for each activity identified. The project plans will reflect, on an on-going basis, delivery of target interfaces as discussed and agreed to within each preceding section.
- 9.2 AT&T and BellSouth recognize that the preceding project plans are not sufficient to fully resolve all technical and operational details related to the interfaces described. Therefore, AT&T and BellSouth agree to document the additional technical and operational details in the form of a Joint Implementation Agreement (JIA). These JIAs may be modified by mutual agreement of the Parties.
- 9.3 AT&T and BellSouth agree to document both a topical outline for the JIAs, and establish a schedule for identifying, discussing, resolving and documenting resolution of issues related to each aspect of the JIA topical

outline for each interface discussed in this document. In no case will either end-to-end integrity testing or load testing begin without both Parties mutually agreeing that each interface JIA documents the intended operation of the interface scheduled for testing. By mutual agreement, specific paragraphs or entire sections of the overall Agreement may be identified and documented to serve the purpose described for the Joint Implementation Agreement for specific interfaces. Any issues identified and subsequently resolved through either the end-to-end integrity or load testing processes will be incorporated into the impacted interface JIA within 30 days of issue resolution.

9.4 Performance measurements shall be established pursuant to Section 12 of the General Terms and Conditions of this Agreement.

10. **Other Agreements**

10.1 This Attachment 15 reflects compromises on the part of both AT&T and BellSouth. By accepting this Attachment 15, AT&T does not waive its right to non-discriminatory access to Operations Support Systems of BellSouth.

10.2 AT&T and BellSouth agree that the same interfaces will be utilized for all states within the operating area of BellSouth unless the Parties mutually agree to do otherwise.

OFFICE COPY



Marsha E. Rule  
Attorney

Suite 700  
101 N. Monroe St.  
Tallahassee, FL 32301  
904 425-6365  
FAX: 904 425-6361

June 10, 1997

Mrs. Blanca S. Bayo, Director  
Division of Records and Reporting  
Florida Public Service Commission  
2540 Shumard Oak Boulevard  
Tallahassee, FL 32399-0850

Docket No. 960833-TP

Dear Mrs. Bayo:

Attached please find some additional provisions to the Interconnection Agreement between AT&T and BellSouth. AT&T and BellSouth have mutually agreed to the attached provisions through negotiations which occurred subsequent to the Commission's approval of the Interconnection Agreement. The attached provisions will form a part of the Interconnection Agreement between AT&T and BellSouth when approved by the Commission.

Sincerely,

*Marsha E. Rule*  
*dmf*

Marsha E. Rule

Enclosures

cc: All Parties of Record

**12. Performance Measurement**

- 12.1 In providing Services and Elements, BellSouth will provide AT&T with the quality of service BellSouth provides itself and its end-users. BellSouth's performance under this Agreement shall provide AT&T with the capability to meet standards or other measurements that are at least equal to the level that BellSouth provides or is required to provide by law or its own internal procedures. BellSouth shall satisfy all service standards, measurements, and performance requirements set forth in the Agreement and the measurements specified in Attachment 12 of this Agreement. Any conflict between the standards, measurements, and performance requirements BellSouth provides itself and the standards, measurements and performance requirements set forth in Attachment 12 shall be resolved in favor of the higher standard, measurement and performance.
- 12.2 The Parties acknowledge that the need will arise for changes to the measurements specified in Attachment 12 during the term of this Agreement. Such changes may include the addition or deletion of measurements or a change in the performance standard for any particular metric, as well as the provision of target performance levels, as set forth in Attachment 12. Unless otherwise specified in Attachment 12, the parties agree to review all measurements on a quarterly basis to determine if any changes are appropriate, and may include the provision to AT&T of any additional measurements BellSouth may provide itself.
- 12.3 The Parties agree to monitor actual performance on a monthly basis and, if the Parties conclude it is required, develop a process improvement plan to improve quality of service provided as measured by the performance measurements, if necessary. Such a plan shall be developed where BellSouth's performance falls below either the level of performance it provides itself or the level of performance required in Attachment 12.

**13. DELETED****14. Force Majeure**

- 14.1 Neither Party shall be liable for any delay or failure in performance of any part of this Agreement caused by a Force Majeure condition, including acts of the United States of America or any state, territory or political subdivision thereof, acts of God or a public enemy, fires, floods, disputes, freight embargoes, strikes, earthquakes, volcanic actions, wars, civil disturbances, or other causes beyond the reasonable control of the Party claiming excusable delay or other failure to perform. Force Majeure shall not include acts of any Governmental Authority relating to environmental, health or safety conditions at Work Locations. If any Force Majeure condition occurs, the Party whose



performance fails or is delayed because of such Force Majeure condition shall give prompt notice to the other Party, and upon cessation of such Force Majeure condition, shall give like notice and commence performance hereunder as promptly as reasonably practicable.

14.2

Notwithstanding Subsection 1, no delay or other failure to perform shall be excused pursuant to this Section 14 by the acts or omission of a Party's

<b>Signal Transfer Points</b>	
ISUP	\$0.00001 per message
TCAP	\$0.00004 per message
Usage surrogate	\$64.00 per month
<b>Service Control Points</b>	
LIDB (1)	TBD
Toll Free Database (1)	TBD
AIN, per message	\$0.00604 (interim rate)
AIN, Service Creation Tools (1)	TBD
AIN, Mediation (1)	TBD
(1) BellSouth and AT&T shall negotiate rates for this offering. If agreement is not reached within sixty (60) days of the Effective Date, either party may petition the Florida PSC to settle the disputed charge or charges.	
<b>Call Transport and Termination (2)</b>	
Direct End Office interconnection	\$ .002 per MOU
Interconnection at the Tandem Switch, - Tandem switch + transport - End Office Switch - Combined	\$ .00125 per MOU \$ .00200 per MOU \$ .00325 per MOU
(2) The Parties agree to bill a mutually agreed upon composite interconnection rate of \$0.002 until approximately January, 1998, unless otherwise agreed to by the parties. This interim composite rate will be billed in lieu of interconnection rates on an elemental basis and shall be retroactive to the Effective Date.	

**TABLE 3**

**RIGHTS OF WAY**

BellSouth shall provide access to rights-of-way at rates that are consistent with Section 224 of the Telecommunications Act of 1934.

- 13.4.2.21 BellSouth shall accept queries to LIDB associated with AT&T customer records, and shall return responses in accordance with the requirements of Section 13.8.5.
- 13.4.2.22 BellSouth shall provide mean processing time at the LIDB within 0.50 seconds under normal conditions as defined in the technical reference in Section 13.8.5 of this Attachment.
- 13.4.2.23 BellSouth shall provide processing time at the LIDB within 1 second for 99% of all messages under normal conditions as defined in the technical reference in Section 13.8.5 of this Attachment.
- 13.4.2.24 BellSouth shall provide 99.9 % of all LIDB queries in a round trip within 2 seconds as defined in the technical reference in Section 13.8.5.
- 13.4.2.25 BellSouth shall provide data in LIDB replies with no more than 2% unexpected data values. Per BellCORE document SR334, because the majority of the error (i.e., fraud attempts, customer or operator misdialing, and CPE malfunctions) are beyond the LIDB owner, Unexpected Data Value - PIN Mismatch should not be considered measurement of BellSouth LIDB quality. However, should this value exceed 2% AT&T and BellSouth will jointly agree if and when root cause analysis is necessary.
- 13.4.3 **Interface Requirements**  
BellSouth shall offer LIDB in accordance with the requirements of this subsection 13.4.3.
- 13.4.3.1 The interface to LIDB shall be in accordance with the technical reference in Section 13.8.3 of this Attachment.
- 13.4.3.2 The CCS interface to LIDB shall be the standard interface described in Section 13.8.3 of this Attachment.
- 13.4.3.3 The LIDB Data Base interpretation of the ANSI-TCAP messages shall comply with the technical reference in Section 13.8.4 of this Attachment. Global Title Translation shall be maintained in the signaling network in order to support signaling network routing to the LIDB.
- 13.5 **Toll Free Number Database**  
The Toll Free Number Database is a SCP that provides functionality necessary for toll free (e.g., 800 and 888) number services by providing routing information and additional so-called vertical features during call set-up in response to queries from SSPs. This Subsection 13.5 supplements the requirements of Subsections 13.2 and 31.8 of this

Agreement. BellSouth shall provide the Toll Free Number Database in accordance with the following:

13.5.1 **Technical Requirements**

13.5.1.1 BellSouth shall make BellSouth Toll Free Number Database available for AT&T to query with a toll-free number and originating information.

- 16.2.3.5.8 AT&T Technical Reference TR 62421, December 1989. ACCUNET Spectrum of Digital Services Description And Interface Specification. Also TR 62421A Addendum 2 November 1992.
- 16.2.3.5.9 AT&T Data Communications Technical Reference TR 62310, August 1993, DS0 Digital Local Channel Description And Interface Specification. Also Addendum 2 November 1992.
- 16.2.3.5.10 AT&T Technical Reference TR 54014, 1992, ACCUNET T45 and T45 Reserved Services - Service Description And Interface Specification.
- 16.2.3.5.11 AT&T Technical Reference TR 54018, most current issue, ACCUNET T155 Service Description And Interface Specification.

16.2.4 **Services and Capabilities**

16.2.4.1 All Network Elements shall provide performance sufficient, in combination with other Network Elements, to provide the following applications in accordance with the requirements of this document:

16.2.4.1.1 Voice services.

16.2.4.1.2 Voice-band data modem connections up to 9.6 kbps and up to and including 28.8 kbps V.34 when available.

16.2.4.1.3 FAX transmissions up to and including 14.4 kbps group 3.

16.2.4.1.4 CLASS/LASS features.

16.2.4.1.5 Operator Systems.

16.2.4.2 Where available, the following capabilities shall be provided as applicable:

16.2.4.2.1 ISDN BRI

16.2.4.2.2 ISDN PRI

16.2.4.2.3 Switched Digital Data

16.2.4.2.4 Non-Switched Digital Data

16.2.4.2.5 Types of Video applications

16.2.4.2.6 Coin Services

16.2.4.2.7 Frame Relay and ATM

16.2.4.2.8 Private Line Services

16.2.5 Specific Performance Requirements

BellSouth shall comply with the following performance requirements to the extent that they are consistent with the greater of BellSouth's actual performance or applicable industry standards. If AT&T requests performance requirements that exceed either the industry standards or the actual performance that BellSouth provides to itself, then AT&T shall request such performance through the Bona Fide Request process set forth in Section 1.1 of the General Terms and Conditions of this Agreement.

16.2.5.1 BellSouth shall provide performance equal to or better than all of the requirements set forth in this Section. Unless noted otherwise, requirements and objectives are given in terms of specific limits. This means that all tests (acceptance and ongoing performance) shall meet the limit(s) to satisfy the requirement.

16.2.5.2 **Performance Allocation** Transmission path impairments may be classified as either analog or digital, and will depend on the nature of the signal transmitted across the Network Element. Analog impairments are introduced on any analog portion of the loop, typically between the NID portion of Loop Distribution and the analog to digital (A/D) conversion, and are usually correlated with the length of the physical plant. Digital impairments are introduced by A/D conversion and by interfaces between digital Network Elements. In addition, noise can be introduced by either analog transmission or the A/D conversion.

16.2.5.3 **Loop Combination Architecture Constraints**

16.2.5.3.1 The following constraints will limit not only the variety of Loop Combination architectures that may be considered, but also the architectures BellSouth may consider to deliver any Ancillary Function or Network Element. These constraints apply to the entire path between the NID portion of Loop Distribution and BellSouth switch. Any exceptions to these restrictions shall be specifically requested or approved by AT&T in writing.

16.2.5.3.1.1 **DELETED**

16.2.5.3.1.2 No more than 1, 2-to-4-wire hybrid.

16.2.5.3.1.3 No voice compression.

16.2.5.3.1.4 No echo cancelers or suppressers.

no pulses of either positive or negative polarity have occurred. An OOF condition shall be declared when either Network equipment or Digital Terminal Equipment detects errors in the framing pattern.

16.2.5.4.2.6.2 There shall be fewer than 1 SFE per month.

**16.2.5.5 Service Availability and Reliability**

Availability refers to the time period during which the service is up and usable for its intended purpose. Reliability refers to the probability that a task will be completed successfully, given that it is successfully begun. Where available BellSouth shall provide real-time, remote data access to performance monitoring and alarm data on events affecting (or potentially affecting) AT&T's traffic.

**16.2.5.5.1 Blocked Calls**

16.2.5.5.1.1 Blocking is the fraction of call origination attempts denied service during a stated measurement period. Blocking occurs because of competition for limited resources within the network.

16.2.5.5.1.2 For intraLATA toll service as well as for local exchange service, the blocking level from originating network interface (NID) to terminating NID shall not exceed 1% in any hour, except under conditions of service disruption. For access to or egress from the AT&T long distance network, the blocking rate shall not exceed 0.5% in any hour, except under conditions of service disruption.

**16.2.5.5.2 Blocked Dial Tone**

16.2.5.5.2.1 Blocked dial tone occurs when the subscriber does not receive dial tone within the time frame, measured in seconds of going off-hook, equal to that which BellSouth provides itself or its end-users.

16.2.5.5.2.2 Customers shall not experience more than 0.1% dial tone blocking during average busy season busy hour (ABSBH).

**16.2.5.5.3 Downtime**

Downtime is the period of time that a system is in a failed state.

16.2.5.5.3.1 The average downtime for all subscriber Loop Combinations shall be less than 49 minutes per year. The maximum downtime for 99% of all subscriber Loop Combinations shall be less than 74 minutes per year.

16.2.5.5.3.2 The average downtime for an end office switch shall be less than 3 minutes per year. The average downtime for individual trunks shall be less than 28 minutes per year. The average downtime for digital trunk groups shall be less than 20 minutes per year. The average downtime



- 3.1.10 Prior to AT&T sending BellSouth the first service order, AT&T shall review the procedures that all BellSouth service technicians who provide repair service for AT&T Customers shall follow in all their communications with AT&T Customers. At a minimum, the aforementioned procedures shall assume that: (1) BellSouth technicians shall provide repair service that is at least equal in quality to that provided to BellSouth customers; (2) trouble calls from AT&T Customers shall receive response time priority that is at least equal to that of BellSouth customers and shall be handled on a "first come first served" basis regardless of whether the customer is an AT&T Customer or a BellSouth customer.
4. BellSouth shall provide AT&T with the same scheduled and non-scheduled maintenance, including, without limitation, required and recommended maintenance intervals and procedures, for all Local Services, Unbundled Network Elements and Combinations provided to AT&T under this Agreement that it currently provides for the maintenance of its own network. Procedures for scheduled and non-scheduled maintenance will be documented in the Workcenter Interface Agreement.
- 4.1 BellSouth shall negotiate the release (authorization to interrupt service) of any Unbundled Network Elements or Large Business customers' service with AT&T prior to any scheduled maintenance activity which may impact those services.
- 4.2 For services provided through resale, BellSouth agrees to provide AT&T with scheduled maintenance for residence and small business customers' consistent with that which it provides its own customers. BellSouth agrees to provide AT&T written notification of Central Office conversions and such conversions will occur after midnight and before 4 A.M.
5. **DELETED**
6. **DELETED**
7. On misdirected calls BellSouth and AT&T shall advise customers to contact their Local Service Provider and will provide the customer with the Local Service Provider contact number.
8. BellSouth repair bureau shall conform to the following performance and service quality standards when providing repair and maintenance to AT&T and AT&T Customers under this Agreement:

- 8.14 technician shall, (i) contact AT&T for authorization, (ii) provide an estimate of time and materials required, (iii) quote time and charges at the completion of the repair visit, (iv) notify AT&T if a subsequent visit is required. BellSouth will bill maintenance charges for premises visits to AT&T.
- 8.15 When maintenance charges are incurred during premises visits, the BellSouth technician shall present the Customer with a form that is consistent with Section 19 of the General Terms and Conditions of this Agreement detailing the time spent, the materials used, and an indication that the trouble has either been resolved, or that additional work will be necessary, in which case, BellSouth technician shall make an additional appointment with the Customer. The BellSouth technician shall obtain the Customer's signature upon said form, and then use the signed form to input maintenance charges into BellSouth's database (accessible by way of the Electronic Interface established pursuant to Section 3 preceding).

## PERFORMANCE MEASUREMENT

### **1. PERFORMANCE MEASUREMENT**

1.1 BellSouth, in providing Services and Elements to AT&T pursuant to this Agreement, shall provide AT&T the same quality of service that BellSouth provides itself and its end-users. This Attachment 12 includes AT&T's measurements for those requirements. The Parties have agreed to five (5) categories of Performance to be measured: (1) Provisioning; (2) Maintenance; (3) Billing (Data Usage and Data Carrier); (4) Databases, e.g., LIDB and (5) Account Maintenance. Each category includes measurements which focus on timeliness, accuracy and quality. BellSouth shall measure the following activities to meet the goals provided herein.

1.2 Except as otherwise provided in this Attachment 12, BellSouth shall provide data on a monthly basis for each state and for the nine states served by BellSouth. The data shall be reported to AT&T in a mutually agreed upon format which will enable AT&T to compare BellSouth's performance for itself with respect to a specific measure to BellSouth's performance for AT&T for that same specific measure. BellSouth shall also provide the raw data used to calculate each measurement for AT&T as reasonably requested by AT&T. For provisioning and maintenance, separate measurements shall be provided as follows:

- POTS/Non-Design
  - Residence - Dispatch Out/Non-Dispatch Out
  - Business - Dispatch Out/Non-Dispatch Out
- UNE - Dispatch Out/Non-Dispatch Out
- Local Interconnection/Trunking
- Specials - Design Only

### **1.3 DELETED**

1.4 BellSouth and AT&T recognize that percentage target performance levels have not been provided for all measurements and that such targets for certain categories of performance will be required to improve performance, to maintain parity with that which BellSouth has obligated itself to provide under this Agreement, or to improve service as AT&T and BellSouth may mutually agree. BellSouth and AT&T agree to meet to discuss establishment of such targets quarterly, starting no later than

ninety (90) days after actual performance occurs. Such targets will reflect a negotiated level of performance. Notwithstanding the foregoing, AT&T reserves its right to request targets that exceed parity. Such a request may require AT&T to reimburse BellSouth for the reasonable and demonstrable cost BellSouth incurs to provide such performance, as the Parties may mutually agree.

## 2. PROVISIONING PERFORMANCE MEASUREMENTS

Provisioning performed by BellSouth will meet the following measurements:

- 2.1 **Desired Due Date:** Measures as a percent how often BellSouth is able to meet AT&T's desired due date for provisioning Services, Elements, or Combinations. BellSouth has stated that it cannot provide this measurement at this time. The Parties agree to review BellSouth's ability to provide Desired Due Date no later than October 1, 1997. Until such time as BellSouth provides this measurement, BellSouth agrees to provide a range of intervals provided below that it represents are reflective of the time it takes to install Services, Elements, or Combinations. BellSouth shall measure and provide data on the performance intervals (for each of BellSouth and AT&T Customers) and the Parties agree to meet to review interval data to assess whether the intervals should be improved, no later than August 1, 1997. In addition, BellSouth and AT&T shall jointly develop by July 1, 1997, an audit plan that will provide data to demonstrate that the intervals provided by BellSouth to AT&T are at parity with those BellSouth provided itself or its end-users.

Service	Interval
INSTALLATION	
Lines/trunks with no premises visit:	
<i>Business</i>	
1-3 lines	≤ 2 business days*
4-15	≤ 4 business days*
Over 15 lines	AS NEGOTIATED
<i>Residential</i>	≤ 2 business days*
Lines/trunks with premises visit:	

\* Under normal business conditions

<i>Business</i>	
1-2 lines	2 business days*
3-5 lines	4 business days*
6-10 lines	6 business days*
11-15	9 business days*
Over 15 lines	AS NEGOTIATED
<i>Residential</i>	4 days*
Business lines/trunks; plant or other facilities not available and must be provisioned	AS NEGOTIATED
ESSX®/Multi Serv (Centrex) <sup>(sm)</sup>	
New/To & From	AS NEGOTIATED
New features (not in common block)	AS NEGOTIATED
Add/changes (in common block)	
1-3 lines	2 business days
4-9 lines	3 business days
10-24 lines	5 business days
Over 24 lines	AS NEGOTIATED
<b>Unbundled Network Elements</b>	
<i>Business or Residential</i>	The Parties agree to establish appropriate intervals for provisioning unbundled Network Elements by July 1, 1997.
<b>FEATURE CHANGES</b>	

\* Under normal business conditions

Orders received before 3:00pm	Completed on day of receipt
Orders received after 3:00pm	Completed before 5:00pm next business day
<b>SERVICE DISCONNECTS</b>	
With no premises visits	
<i>Business or Residential</i>	Within 24 hours after receipt of Service Order

**2.2 Committed Due Date Met:**  
Measures as a percent the actual date service provisioned compared to the date service was scheduled to be provisioned.

Measurement:

$$N = \text{Total Appointments Met}$$

$$D = \text{Total Appointments Set}$$

**2.3 No Trouble Reported Within 30 Days of Order Completion:**  
Measures reliability of service provided to AT&T customers in first 30 days of service.

Measurement:

**POTS:**  $N = \frac{\text{All troubles on service installed } \leq 30 \text{ days in a calendar month}}{\text{Installations in a calendar month}}$   
Note: N and D are not the same order base.

**Specials:**  $N = \frac{\text{Troubles on service installed } \leq 30 \text{ days}}{\text{Installations in a calendar month}}$   
Note: N and D are in the same order base.

**2.4 Firm Order Confirmation:**

Measures the timeliness of receiving a validation that the service ordered will be provisioned.

Measurement:

$$N = \text{Total Number of FOCs Sent for the segment of each 24 hour period}$$

$$D = \text{Total Number of FOCs Sent in a 24 hour period}$$

BellSouth agrees to collect and measure data in 4 hour segments through September 1, 1997. At that time, AT&T and BellSouth will review BellSouth's ability to provide an Electronic FOC in four hours or less.

2.5 Notice of Reject or Error Status Within 1 Hour of Receipt (Paper/Electronic):

Measures the timeliness of receiving notification that a service order is incorrect and needs to be corrected.

Measurement:

$$N = \frac{\text{Number of Rejects or Error Status Sent in } \leq 1 \text{ hour}}{\text{Total Number of Rejects or Error Status Sent}}$$

2.6 Service Orders Provisioned As Requested:

(BellSouth and AT&T agree to review appropriate information and develop a proposal to provide this measurement no later than August 1, 1997.

3. MAINTENANCE MEASUREMENTS

3.1 Time to Restore

Measures average time it takes to restore to service Local Services, Network Elements, or Combinations.

Measurement:

$$N = \frac{\text{Total Duration Time}}{\text{Total Troubles}}$$

For Specials and Local Interconnection/Trunking:

$$N = \frac{\text{Responsible Duration Time}}{\text{Total Troubles}}$$

AT&T has requested that BellSouth measure the time to restore Local Services, Network Elements or Combinations, separated between time to restore where no dispatch is required, time to restore where dispatch is required and time to restore a service impairment. In addition, AT&T has requested BellSouth to provide these measurements delineated in certain hourly intervals. BellSouth is agreeable to meeting this request for hourly intervals as delineated by AT&T, subject to an estimated one-time cost of \$20,000.00 and a monthly recurring cost of \$500.00. AT&T agrees to give BellSouth thirty (30) days written notice of

its desire for BellSouth to provide this measurement and, subject to final agreement on cost (one-time and monthly), BellSouth will provide it as requested, within ninety (90) days unless otherwise agreed.

**3.2 Repeat Troubles**

Measures trouble reports from the same customer in a 30 day period.

$$N = \frac{\text{Total Repeats} < 30 \text{ days}}{\text{Total Troubles}}$$

**3.3 Trouble Resolution Notification**

BellSouth shall inform AT&T of the restoration of Local Service, Network Element, or Combination after an outage has occurred by means of a telephone call until such time as a mechanized means of notification becomes available.

**3.4** AT&T will transmit repair calls to the BellSouth repair bureau by telephone until it is able to make use of the Electronic Interfaces pursuant to Attachment 15. BellSouth shall measure the average length of time it takes for the BellSouth repair bureau attendant to answer the telephone.

**3.5 Missed Appointments**

Measures when BellSouth misses meeting end user appointments that require a premise visit.

Measurement:

$$N = \frac{\text{Total Appointments met}}{\text{Total Appointment set}}$$

**3.6 Report Rate**

Measures the frequency of troubles reported within BellSouth's network.

Measurement:

$$N = \frac{\text{Number of Trouble Reports per month}}{\text{Total number of Lines}}$$

**4. BILLING (CUSTOMER USAGE DATA)**

**4.1 Timeliness**



BellSouth will mechanically transmit, via CONNECT:Direct, all usage records to AT&T's Message Processing Center once daily.

Measurement:

$$N = \frac{\text{Total Number of Messages Sent within six (6) calendar days from Initial Recording}}{\text{Total Number of Messages Sent}}$$

D = Total Number of Messages Sent

Target:  $\geq 95\%$  of all messages will be delivered within 6 calendar days from initial recording.

#### 4.2 Completeness

BellSouth will provide all required Recorded Usage Data and ensure that it is processed and transmitted within thirty (30) days of the message create date.

Measurement:

$$N = \frac{\text{Total number of Recorded Usage Data records delivered during the current month that are within thirty (30) days of the message create date.}}{\text{Total number of Recorded Usage Data Records delivered during the current month}} \times 100$$

D = Total number of Recorded Usage Data Records delivered during the current month

Target:  $\geq 98\%$  of all records delivered within 30 days of the message creation

#### 4.3 Recorded Usage Data Accuracy

##### 4.3.1 Format and Content

BellSouth will provide Recorded Usage Data in the format and with the content as defined in the current BellCore EMR document.

Measurement:

$$N = \frac{\text{Total Number of Recorded Usage Data Transmitted Correctly}}{\text{Total Number of Recorded Usage Data Transmitted}} \times 100$$

D = Total Number of Recorded Usage Data Transmitted

Target:                    ≥ 98% of all recorded records delivered will be transmitted correctly

#### 4.3.2 Transmission

BellSouth will ensure that the Recorded Usage Data is transmitted to AT&T error free. The level of detail includes, but is not limited to: detail required to Rating the call, Duration of the call, and Correct Originating/Terminating information pertaining to the call. The error is reported to BellSouth as a Modification Request (MR). The type of MR that corresponds with each MR response time classification shall be mutually determined. Performance is to be measured and reported in accordance with the MR response times described below:

MR Response Times:

A = Immediate Attention - Resolution within 24 hours

B = Resolution 4 to 7 Days - Unguidables

C = Resolution 2 to 3 Weeks

D = Resolution 1 to 2 Months - Changes Which Need to be Made

R = Resend (Files) within 6 Hours

All times refer to mutual business work days/hours

#### 4.4 Data Packs

Data Pack rejections and resends shall be as defined in Attachment 7, Appendix 2, Sections 4.4 and 4.5. BellSouth will transmit to AT&T all packs error free in the format agreed.

Measurement:

$$N = \frac{\text{Total Number of Data Packs Sent Error Free}}{\text{Total Number of Data Packs Sent}}$$

D = Total Number of Data Packs Sent

Target:                    96% of all Packs transmitted in a calendar month will be accepted.

**5. BILLING (CONNECTIVITY BILLING AND RECORDING)**

- 5.1 The Parties have agreed to negotiate a pre-bill certification (Future Optimum State - FOS) process as set forth in Section 12 of Attachment 6. This certification process shall include appropriate performance measurements and shall be completed within 120 days of execution of the Agreement.

**6. DATA BASES****6.1 Line Information Data Base**

- 6.1.1 BellSouth shall provide processing time at the Line Information Data Base ("LIDB") within 1 second for 99% of all messages under normal conditions as defined in the technical reference in Section 13.8.5 of Attachment 2.
- 6.1.2 BellSouth shall provide 99.9 % of all LIDB queries in a round trip within 2 seconds as defined in the technical reference in Section 13.8.5 of Attachment 2.
- 6.1.3 Once appropriate data can be derived from LIDB, BellSouth shall measure the following:
- 6.1.3.1 There shall be at least a 99.9.% reply rate to all query attempts.
- 6.1.3.2 Queries shall time out at LIDB no more than 0.1% of the time.
- 6.1.3.3 **DELETED**
- 6.1.3.4 Group troubles shall occur for no more than 1% of all LIDB queries. Group troubles include responses other than:
- 6.1.3.4.1 Missing Group - The group is not defined in LIBD (when reply is returned "vacant" but there is no active record for the 6-digit NPA-NXX group.)
- 6.1.3.4.2 Vacant Code - When a 6-digit NPA-NXX is defined as vacant in LIDB but no active line is associated with that NPA-NXX code.
- 6.1.3.5 Once AT&T requests LIDB screening pursuant to Section 13.4.2.20 of Attachment 2, the Parties shall negotiate the appropriate performance standard for defects in LIDB Data Screening of responses.

**7. ACCOUNT MAINTENANCE**

- 7.1 When notified by a CLEC that an AT&T Customer has switched to CLEC service, BellSouth shall provision the change, and notify AT&T via

**CONNECT:** Direct that the customer has changed to another service provider ("OUTPLOC") within one (1) business day:

**Measurement:**

**N = Number of Local Service Changes From AT&T to Another CLEC Provisioned with Notification to AT&T in One Business Day**

**D = Total Number of Local Service Changes from AT&T to Another CLEC Provisioned with Notification to AT&T**

- 7.2 When notified by AT&T that a customer has changed his/her PIC only from one interexchange carrier to another carrier, BellSouth shall provision the PIC only change and convey the confirmation of the PIC change via the work order completion feed within one (1) business day.

**Measurement:**

**N = Number of PIC Only Changes from One IEC to Another Initiated by AT&T Provisioned with Notification via the Work Order Completion Feed in  $\leq$  One Business Day**

**D = Total Number of PIC Only Changes from One IEC to Another Initiated by AT&T Provisioned with Notification via the Work Order Completion Feed**

- 7.3 If notified by an interexchange carrier using an '01' PIC order record that an AT&T Customer has changed his/her PIC only, BellSouth will reject the order and notify that interexchange carrier a CARE PIC record should be sent to the serving CLEC for processing within one (1) business day of BellSouth's receipt of the PIC order from the IXC.

**Measurement:**

**N = Number of PIC Change Requests for an AT&T Local Customer Rejected by BellSouth to IXC  $\leq$  One Business Day**

**D = Total Number of PIC Changes for an AT&T Local Customer Rejected by BellSouth to IXC**



Tracy Hatch  
Attorney

Suite 700  
101 N. Monroe St.  
Tallahassee, FL 32301  
904 425-6364  
FAX: 904 425-6361

August 21, 1997

Mrs. Blanca Bayo, Director  
Bureau of Records and Reporting  
Florida Public Service Commission  
2540 Shumard Oak Boulevard  
Tallahassee, FL 32399

Re: Docket No. 960833-TP

Dear Mrs. Bayo:

Attached please find technical provisions to the Interconnection Agreement between AT&T and BellSouth. AT&T and BellSouth have mutually agreed to the attached provisions through negotiations which occurred subsequent to the Commission's approval of the Interconnection Agreement. The attached provisions form a part of the Interconnection Agreement between AT&T and BellSouth approved by the Commission on June 19, 1997.

Sincerely,

Tracy Hatch

TH:sad

Enclosures

cc: ✓ Nancy B. White, Esq.  
Richard D. Melson, Esq.

RECEIVED

AUG 22 1997

U.S. MAIL-REG. RELATIONS  
TALLAHASSEE, FL

HQ REGULATORY-ATLA  
MIAMI LEGAL  
AML

FAX \_\_\_\_\_ FED X ✓

TRUNKING

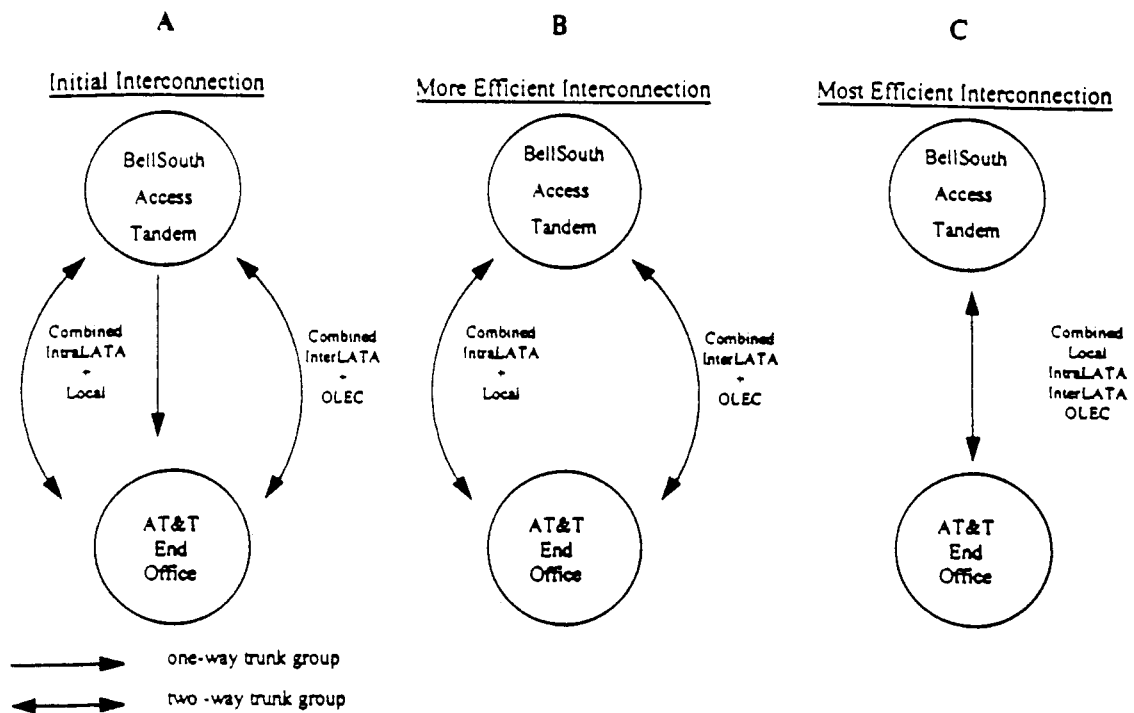

- 16.6.1.5 Notwithstanding Section 16.6.1.4, AT&T may, at its option, use its toll access egress trunk groups to terminate outbound local, intrastate toll and interstate toll traffic destined for BellSouth, ICOs, and CLECs at no additional cost to AT&T.
- 16.6.1.6 All trunking provided by BellSouth shall adhere to the applicable performance requirements set forth in Section 16.2 of Attachment 2.
- 16.6.1.7 At AT&T's request, BellSouth shall provide for overflow routing from a given high usage trunk group or groups onto another final tandem trunk group.
- 16.6.1.8 BellSouth and AT&T shall agree on the establishment of two-way trunk groups for the exchange of traffic for other IXCs. These trunk groups can be provided in a "meet point" arrangement.
- 16.6.1.9 Interconnection shall be made available upon AT&T's request at any technically feasible point of interface. All trunk interconnections shall be provided, including, SS7, MF, DTMF, DialPulse, PRI-ISDN (where available), DID (Direct Inward Dialing), CAMA-ANI, and trunking necessary so that interim LNP can be provided.

**16.6.1.10 Trunk Interface Requirements**

**16.6.1.10.1 B911/E911 Trunks**

Customer originates traffic and AT&T sends it to BellSouth for termination, AT&T will determine whether the traffic is local or toll. When a BellSouth Customer originates traffic and BellSouth sends it to AT&T for termination, BellSouth will determine whether the traffic is local or toll. Each Party will provide the other with information that will allow it to distinguish among local, intrastate toll and interstate toll traffic. At a minimum, each Party shall utilize NXXs in such a way that the other Party shall be able to distinguish local from intraLATA toll traffic. Where the originating Party cannot provide the terminating Party with actual usage data to enable the terminating Party to distinguish a local call from a toll call, the originating Party will report to the terminating Party its Percent Local Usage ("PLU") factors and the application of such PLUs will determine the amount of local minutes to be billed to the terminating Party. PLUs will be sent monthly or quarterly, as mutually agreed to by the Parties. Each Party may audit the traffic reported to it by the other Party as provided for in Section 11.2 of the General Terms and Conditions to this Agreement. When AT&T interconnects with BellSouth's network for the purpose of completing local and toll traffic, AT&T will, at its option, interconnect at either the tandem or end office switch to complete such calls paying local interconnection rates for its customers' local calls and switched access rates for its customers' toll calls. Such interconnection will be ordered as needed by AT&T to complete such local and toll calls. Further, the Local Traffic exchanged pursuant to this Attachment shall be measured in billing minutes of use and shall be in actual conversation seconds. The total conversation seconds per chargeable traffic type will be totaled for the entire monthly billing cycle and then rounded to the next whole conversation minute. Reciprocal compensation for the termination of this Local Traffic shall be in accordance with Part IV to this Agreement. Except as provided in Section 11.2 of the General Terms and Conditions of this Agreement, each Party agrees not to charge the other Party for any costs incurred as a result of providing such Party with PLUs in lieu of sending actual usage data to distinguish local and toll traffic.

**6. Local Number Portability**

**6.1 DELETED**

**6.2** When an IXC terminates an interLATA or IntraLATA toll call to an AT&T local exchange customer whose telephone number has been ported from BellSouth, the Parties agree that AT&T shall receive those IXC access charges associated with end office switching, local transport, RIC and CCL, as appropriate. BellSouth shall receive any access tandem fees, dedicated and common-transport charges, to the extent provided by BellSouth, and any INP fees (i.e., such as RCF charges) set forth in this Agreement. When a call



for which access charges are not applicable is terminated to an AT&T local exchange customer whose telephone number has been ported from BellSouth, and is terminated on AT&T's own switch, the Parties agree that the mutual compensation arrangements described in this Agreement shall apply.

**7. Issuance of Bills - General**

- 7.1 BellSouth and AT&T will issue all bills in accordance with the terms and conditions set forth in this Section. BellSouth and AT&T will establish

forth in the Section 16 of the General Terms and Conditions of this Agreement and Attachment 1.

- 14.2 If a Party disputes a charge and does not pay such charge by the payment due date, such charges shall be subject to late payment charges as set forth in the Late Payment Charges provision of this Attachment. If a Party disputes charges and the dispute is resolved in favor of such Party, the other Party shall credit the bill of the disputing Party for the amount of the disputed charges along with any late payment charges assessed no later than the second Bill Date after the resolution of the dispute. Accordingly, if a Party disputes charges and the dispute is resolved in favor of the other Party, the disputing Party shall pay the other Party the amount of the disputed charges and any associated late payment charges assessed no later than the second bill payment due date after the resolution of the dispute. In no event, however, shall any late payment charges be assessed on any previously assessed late payment charges.

15. **Late Payment Charges**

If either Party fails to remit payment for any charges described in this Attachment by the payment due date, or if a payment or any portion of a payment is received by either Party after the payment due date, or if a payment or any portion of a payment is received in funds which are not immediately available to the other Party, then a late payment penalty shall be assessed. For bills rendered by BellSouth for payment by AT&T, the late payment charge shall be calculated based on the portion of the payment not received by the payment due date times the late factor as set forth in the following BellSouth tariffs, based upon the service for which payment was not received: for general subscriber services, Section A2 of the General Subscriber Services Tariff; for private line service, Section B2 of the Private Line Service Tariff; and for access service, Section E2 of the Access Service Tariff. For bills rendered by AT&T for payment by BellSouth the late payment charge shall be calculated based on the portion of the payment not received by the payment date times the lesser of (i) one and one-half percent (1 ½%) per month or (ii) the highest interest rate (in decimal value) which may be charged by law for commercial transactions, compounded daily for the number of days from the payment date to and including the date that payment is actually made. In no event, however, shall interest be assessed by AT&T on any previously assessed late payment charges. BellSouth shall only assess interest on previously assessed late payment charges in a state where it has the authority pursuant to its tariffs.

W  
ALA ✓

RECEIVED-PPSC



JUL 24 PM 4:21

Tracy Hatch  
Attorney

July 24, 1998  
RECORDS AND  
REPORTING

Suite 700  
101 N. Monroe St.  
Tallahassee, FL 32301  
904 435-6364  
FAX: 904 435-6381

Mrs. Blanca Bayo, Director  
Bureau of Records and Recording  
Florida Public Service Commission  
2540 Shumard Oak Boulevard  
Tallahassee, FL 32399

Re: **Docket No. 960833-TP** - Petition by AT&T for Arbitration  
of Rates, Terms and Conditions of a Proposed Agreement  
with BellSouth Telecommunications, Inc. concerning  
Interconnection and Resale under the Telecommunications  
Act of 1996

Dear Mrs. Bayo:

Pursuant to Order No. PSC-98-0604-FOF-TP, issued June 25,  
1998 (the Order), AT&T of the Southern States, Inc. (AT&T)  
and BellSouth Telecommunications, Inc. (BellSouth) submit  
the original and fifteen (15) copies of the revisions to the  
BellSouth/AT&T Interconnection Agreement dated June 10, 1997  
and approved by the Commission by Order PSC-97-0724-FOF-TP.  
The revisions incorporate the final rates for certain  
unbundled network elements previously set by the Commission  
on an interim basis and language regarding rates for OSS  
functions. The specific revisions are attached as follows:

1. Part IV: Pricing; Revised Tables 1 and 2  
(revised pages 55-59 of the Agreement)
2. Section 41 - additional language  
(revised page 54 of the agreement)

Please stamp one copy and return it to me for my files.

Thank you for your assistance in this matter.

RECEIVED & FILED

PPSC BUREAU OF RECORDS

Sincerely,

*Tracy Hatch*  
Tracy Hatch

cc: Nancy Sims

38.2 **Rights-of-Way** - The prices that AT&T shall pay to BellSouth are set forth in Table 3.

38.3 **Poles, Ducts and Conduits** - The prices that AT&T shall pay to BellSouth are set forth in Table 4.

39. **Local Number Portability**

The prices for interim number portability are set forth in Table 5.

40. **Recorded Usage Data**

The prices for recorded usage data are set forth in Table 6.

41. **Electronic Interfaces**

Each party shall bear its own cost of developing and implementing Electronic Interface Systems because those systems will benefit all carriers. If a system or process is developed exclusively for certain carriers, however, those costs shall be recovered from the carrier who is requesting the customized system.

The parties acknowledge the Florida Public Service Commission's language in its Order No. PSC-98-0604-FOF-TP dated April 29, 1998 in Docket No. 960833-TP stating: "... BellSouth has a statutory obligation to negotiate or arbitrate this issue when requested to do so by a CLEC" and "... we strongly encourage the parties to negotiate in good faith to establish rates for OSS functions. If, however, the companies are unable to reach agreement through such negotiations, they may of course seek our guidance." (Revised 7/25/98)

TABLE 1

## UNBUNDLED NETWORK ELEMENTS

<b>Network Interface Device</b>	
Per month	\$ 1.08
Installation of 2 wire/4 wire ALEC NID	
NRC First	\$70.32
NRC Add'l	\$54.35
NID to NID Cross Connect, 2 wire or 4 wire, NRC	\$6.15
<b>Loops, including NID</b>	
2 wire, per month	\$ 17.00
NRC First	\$140.00
NRC Add'l	\$ 42.00
4 wire, per month	\$ 30.00
NRC First	\$141.00
NRC Add'l	\$ 43.00
2 wire ISDN, per month	\$ 40.00
NRC First	\$306.00
NRC Add'l	\$283.00
DSL, per month	\$ 80.00
NRC First	\$540.00
NRC Add'l	\$465.00
2 wire ADSL, per month	\$ 15.81
NRC, First	\$113.85
NRC, Add'l	\$ 99.61
2 wire HDSL, per month	\$ 12.12
NRC, First	\$113.85
NRC, Add'l	\$ 99.61
4 wire HDSL, per month	\$ 18.24
NRC, First	\$116.91
NRC, Add'l	\$101.71
<b>Sub-Loops</b>	
Loop Distribution per 2 wire Analog VG Loop, (including NID), per month	\$ 8.57
NRC, First	\$ 78.29
NRC, Add'l	\$ 58.33
Loop Distribution per 4 wire Analog VG Loop (including NID), per	\$ 11.29

month	
NRC, First	\$112.07
NRC, Add'l	\$ 92.11
<b>Unbundled Loop Channelization System (DS1 to VG)</b>	
Per system, per month	\$480.00
NRC, First	\$350.00
NRC, Add'l	\$ 90.00
Per voice interface, per month	\$ 1.50
NRC, First	\$ 5.75
NRC, Add'l	\$ 5.50
<b>End Office Switching</b>	
Ports	
2 wire	\$ 2.00
NRC First	\$ 38.00
NRC Add'l	\$ 15.00
4 wire	\$ 9.14
NRC First	\$ 5.86
NRC Add'l	\$ 5.86
2 wire ISDN	\$ 13.00
NRC First	\$ 88.00
NRC Add'l	\$ 66.00
2 wire DID	TBD
NRC First	TBD
NRC Add'l	TBD
4 wire ISDN	TBD
NRC First	TBD
NRC Add'l	TBD
4 wire DS1	\$125.00
NRC First	\$112.00
NRC Add'l	\$ 91.00
Usage	
Initial Minute	\$0.0175
Additional Minutes	\$0.005
Features, functions, capabilities	No additional charge

<b>Operator Systems</b>	
Operator Call Handling-Station & Person	\$1.00 per minute
Automated Call Handling	\$0.10 per call attempt
Directory Assistance	\$0.25 per call
DA Call Completion	\$0.03 per call attempt
Intercept	\$0.01 per call
Busy Line Verification	\$0.80 per call
Emergency Interrupt	\$1.00 per call
<b>Directory Assistance</b>	
DA Database	
per listing	\$0.001
monthly	\$ 100.00
Direct access to DA service	
per query	\$0.01
monthly	\$5,000.00
NRC, service establish charge	\$ 820.00
DA transport	
Local Channel DS1, per month	\$ 43.64
NRC, first	\$ 242.45
NRC, add'l	\$ 226.44
Dedicated DS1 Level	\$0.6013
Interoffice per mile, per month	
Dedicated DS1 Level	\$ 99.79
Interoffice per facility termination, per month	
NRC, First	\$ 45.91
NRC, Add'l	\$ 44.18
Installation NRC, per trunk or signaling connection	
NRC, first	\$ 206.06
NRC, Add'l	\$ 4.71
Switched Common	
per DA call	\$0.0003
per DA call per mile	\$0.00001
Tandem Switching	
per DA call	\$0.00055
<b>Dedicated Transport</b>	
Dedicated DS1 Level, per mile,	\$0.6013

TABLE 2

PHYSICAL AND VIRTUAL COLLOCATION

Physical Collocation Rates

Rate Element Description	Unit	Recurring Rate	Non-Recurring Rate
Application Fee/Planning Fee	Per Request	\$15.53	\$3,240
Space Preparation Fee	Per Request	N/A	ICB
Space Construction Wire Cage	Per first 100 sq. ft. Per add'l 50 sq. ft.	\$41.99 \$4.14	N/A
Gypsum Board Cage	Per first 100 sq. ft. Per add'l 50 sq. ft.	\$84.10 \$9.35	
Fire Rated Cage	Per first 100 sq. ft. Per add'l 50 sq. ft.	\$99.73 \$11.30	
Floor Space/Land and Building	Per sq. ft.	\$4.25	N/A
Cable Installation	Per Cable	\$2.77	\$1,056
Cable Rack		\$22.94	N/A
Power	Per Amp	\$6.95	N/A
Cross Connects			
2 wire	Per 100 circuits	\$5.24	\$1,157
4 wire		\$5.24	\$1,157
DS1/DCS	Per 100 circuits	\$226.39	\$1,950
DS1/DSX		\$11.51	\$1,950
DS3/DCS	Per 28 circuits	\$56.97	\$528
DS3/DSX		\$10.06	\$528
Optical Circuits	Per 28 circuits Per circuit Per circuit Per connection	\$6.46	\$2,431
Security Escort		N/A	
Regular Time	Per 1/2 hour		\$10.89
Overtime	Per 1/2 hour		\$13.64
Premium Time	Per 1/2 hour		\$16.40
Security Access Cards	Per Request (5 cards)	N/A	\$85.12



Virtual Collocation Rates

Rate Element Description	Unit	Recurring Rate	Non-Recurring Rate
Application Fee/Planning Fee	Initial Request Add'l cable request	N/A	\$4,122 \$1,249
Floor Space/Land and Building	Per sq. ft.	\$4.25	N/A
Cable Installation	Per Cable	\$12.45	\$965
Cable Rack	Per 1/4 Rack	\$2.24	N/A
Power	Per Amp	\$6.95	N/A
Cross Connects			
2 wire	Per 100 circuits	\$5.02	\$1,157
4 wire	Per 100 circuits	\$5.02	\$1,157
DS1/DCS	Per 100 circuits	\$226.39	\$1,950
DS1/DSX	Per 28 circuits	\$11.51	\$1,950
DS3/DCS	Per 28 circuits	\$56.97	\$528
DS3/DSX	Per 28 circuits	\$10.06	\$528
Optical Circuits	Per 28 circuits	\$6.71	\$2,431
	Per circuit		
	Per circuit		
	Per connection		
Virtual to Virtual Connection	Per Cable		
Fiber		\$ .19	\$526.17
DS1/DS3		\$ .17	\$134.46
Equipment Maintenance and Security Escort		N/A	
Regular Time	Per 1/4 hour		\$10.89
Overtime	Per 1/4 hour		\$13.64
Premium Time	Per 1/4 hour		\$16.40

AMENDMENT  
TO INTERCONNECTION AGREEMENT BETWEEN  
BELLSOUTH TELECOMMUNICATIONS, INC.  
AND AT&T COMMUNICATIONS OF THE SOUTHERN  
STATES, INC DATED JUNE 10, 1997  
FLORIDA

Pursuant to this Agreement (the "Amendment"), BellSouth Telecommunications, Inc. ("BellSouth") and AT&T Communications of the Southern States, Inc. ("AT&T"), hereinafter referred to collectively as the "Parties" hereby agree to amend that certain Interconnection Agreement between the Parties June 10, 1997 ("Interconnection Agreement").

NOW THEREFORE, in consideration of the mutual provisions contained herein and other good and valuable consideration, the receipt and sufficiency of which are hereby acknowledged, BellSouth and AT&T hereby covenant and agree as follows:

1. The Preface section is hereby deleted in its entirety and replaced with the following language:

This Agreement, which shall become effective as of the 10<sup>th</sup> day of June, 1997, is entered into by and between AT&T Communications of the Southern States, Inc., a New York corporation, having an office at 1200 Peachtree Street, N.E., Atlanta, Georgia, 30309, on behalf of itself, and its Affiliates, (individually and collectively "AT&T"), and BellSouth Telecommunications, Inc. ("BellSouth"), a Georgia corporation, having an office at 675 West Peachtree Street, Atlanta, Georgia 30375, on behalf of itself and its successors and assigns.

2. Attachment 2 is hereby amended to include the following language as a new section 2.3:

2.3. To the extent AT&T has ordered prior to July 1, 1999, and BellSouth has provisioned, the equivalent of a SmartPath® loop at a rate not to exceed a recurring monthly charge of \$190.00, for a 24 or 28 month commitment period, BellSouth will continue to provision this loop for the remainder of the commitment period.

3. Attachment 2, Section 16.7 is hereby amended to include Section 16.7.3 as follows:

**16.7.3 Access to 911/E911 Emergency Network**

A. 911 and E911 traffic refers to network emergency calls originated by dialing 9-1-1. The Parties agree to cooperate to ensure the seamless operation of emergency call networks, including 911, and E911 calls.

- B. For basic 911 and E911 service, BellSouth will provide to AT&T a list consisting of each municipality in each state that subscribes to either service. The list will also provide, if known, the E911 conversion date for each municipality and, for network routing purposes, a ten-digit directory number representing the appropriate emergency answering position for each municipality subscribing to 911/E911. The parties agree that the county or municipality may wish to assign a different 10-digit directory number for each local exchange company. AT&T agrees to hold this information proprietary and will use the information solely for the purpose of routing 0- calls from the AT&T Operator Services platform to the PSAPs.
- C. AT&T will arrange to accept 911 calls from its end users in municipalities that subscribe to Basic 911 service and translate the 911 call to the appropriate 10-digit directory number as stated on the list provided by BellSouth or to the 10-digit number provided by the county or municipality. AT&T will route that call to BellSouth at the appropriate tandem or end office. When a municipality converts to E911 service, AT&T shall discontinue the Basic 911 procedures and begin the E911 procedures, set forth in subsection 16.7.5, below.
- D. For E911 service, AT&T shall install a minimum of two dedicated trunks originating from AT&T serving wire center and terminating to the appropriate E911 tandem. The dedicated trunks shall be, at a minimum, DS0 level trunks configured either as a 2 wire analog interface or as part of a digital (1.544 Mb/s) interface. Either configuration shall use CAMA type signaling with multifrequency (MF) pulsing that will deliver automatic number identification (ANI) with the voice portion of the call. If the user interface is digital, MF pulses, as well as other AC signals, shall be encoded per the u-255 Law convention. AT&T will provide BellSouth daily updates to the E911 database. BellSouth will provide AT&T, within 48 hours, confirmation of the receipt of said updates.
- E. If a municipality has converted to E911 service, AT&T will forward 911 calls to the appropriate E911 tandem, along with ANI, based upon the current E911 end office to tandem homing arrangement as provided by BellSouth. If the E911 tandem trunks are not available, AT&T will alternatively route the call to a designated 7-digit local number residing in the appropriate PSAP pursuant to the appropriate state statute or regulation. This call will be transported over BellSouth's interoffice network and will not carry the ANI of the calling party.
- F. BellSouth and AT&T agree that the practices and procedures contained in the E911 Local Exchange Carrier Guide For Facility-Based Providers, as it is amended from time to time during the term of this Agreement by BellSouth, shall determine the appropriate procedures and practices of

the parties as to the provision of 911/E911 Access. BellSouth, as the operator of the Automatic Location Identifier (ALI) database, and AT&T will use established processes, procedures and formats described in the E911 Local Exchange Carrier Guide for Facility-Based Providers to interface with AT&T. BellSouth will process valid AT&T customer information with 24 hours of receipt from AT&T, and electronically transfer the AT&T subscriber information to the 911 database.

- G. BellSouth agrees to provide, on a scheduled quarterly basis, copies of the Master Street Address Guide ("MSAG") for the LATAs in which AT&T operates. The appropriate counties authorities to resolve any addressing issues. BellSouth agrees to maintain the MSAG based upon input from and discussions with the appropriate county authorities.
- H. If AT&T's certificated area conforms with BellSouth's exchange boundaries; BellSouth will provide a list of 911 tandems serving the BellSouth exchanges. If AT&T's certificated area does not conform with BellSouth's exchange boundaries, upon request, AT&T's NXXs with the comparable BellSouth NXX, BellSouth will provide to AT&T the information as to which access tandem the AT&T NXXs are routed.

4. Attachment 3 is hereby amended to include a new section 2.6 as follows:

- 2.6 In the event a Collocation Space is wholly or partially damaged by fire, windstorm, tornado, flood or by similar causes to such an extent as to be rendered wholly unsuitable for AT&T's permitted use hereunder, then either party may elect within ten (10) days after such damage, to terminate this Agreement, and if either party shall so elect, by giving the other written notice of termination, both parties shall stand released of and from further liability under the terms hereof. If the Collocation Space shall suffer only minor damage and shall not be rendered wholly unsuitable for AT&T's permitted use, or is damaged and the option to terminate is not exercised by either party, BellSouth covenants and agrees to proceed promptly without expense to AT&T, except for improvements not the property of BellSouth, to repair the damage. BellSouth shall have a reasonable time within which to rebuild or make any repairs, and such rebuilding and repairing shall be subject to delays caused by storms, shortages of labor and materials, government regulations, strikes, walkouts, and causes beyond the control of BellSouth, which causes shall not be construed as limiting factors, but as exemplary only. AT&T may, at its own expense, accelerate the rebuild of its collocated space and equipment provided however that a certified vendor is used and the necessary space preparation has been completed. Rebuild of equipment must be performed by a BellSouth Certified Vendor. If AT&T's acceleration of the project increases the cost of the project, then those additional charges will be incurred by AT&T. Where allowed and where practical, AT&T may erect a temporary facility while BellSouth rebuilds

or makes repairs. In all cases where the Collocation Space shall be rebuilt or repaired, AT&T shall be entitled to an equitable abatement of rent and other charges, depending upon the unsuitability of the Collocation Space for AT&T's permitted use, until such Collocation Space is fully repaired and restored and AT&T's equipment installed therein (but in no event later than thirty (30) days after the Collocation Space is fully repaired and restored).

5. Attachment 6, Section 5.1 is hereby amended to include the following language to the end of this section:

The rates and charges for BellSouth's purchase of facilities to connect its network to AT&T's network shall be as set forth in AT&T's Intrastate Access Services and Interconnection Services Tariff. The rates and charges for AT&T's purchase of facilities to connect its network to BellSouth's network shall be as set forth in BellSouth's Intrastate Access Services Tariff. This provision is specific to AT&T and does not apply to any Affiliates of AT&T that may adopt this agreement.

6. That all of the other provisions of the Interconnection Agreement, dated June 10, 1997 shall remain in full force and effect.

7. BellSouth is hereby authorized to submit this Amendment to the Florida Public Service Commission or other regulatory body having jurisdiction over the subject matter of this Amendment, for approval subject to Section 252(e) of the federal Telecommunications Act of 1996 in accordance with Section 9 of the General Terms and Conditions section of the Agreement.

IN WITNESS WHEREOF, the Parties hereto have caused this Amendment to be executed by their respective duly authorized representatives on the date indicated below.

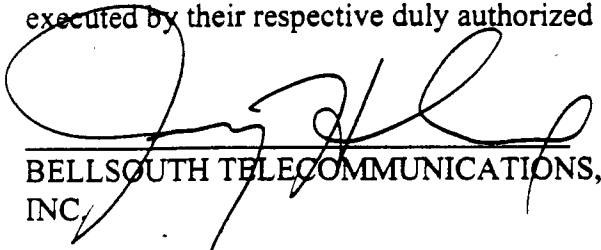
  
BELLSOUTH TELECOMMUNICATIONS,  
INC.

By: Jerry Hendrix

DATE: 7/14/99

  
AT&T COMMUNICATIONS OF THE  
SOUTHERN STATES, INC.

By: Michelle L. Augier

DATE: 7/13/99