

ORIGINAL

LANDERS & PARSONS, P.A.
ATTORNEYS AT LAW

DAVID S. DEE
DIANE K. KIESLING
JOSEPH W. LANDERS, JR.
JOHN T. LAVIA, III
FRED A. McCORMACK
PHILIP S. PARSONS
LESLIE J. PAUGH
ROBERT SCHEFFEL WRIGHT

VICTORIA J. TSCHINKEL
SENIOR CONSULTANT
(NOT A MEMBER OF THE FLORIDA BAR)

MAILING ADDRESS:
POST OFFICE BOX 271
TALLAHASSEE, FL 32302-0271
310 WEST COLLEGE AVENUE
TALLAHASSEE, FL 32301
TELEPHONE (850) 681-0311
TELECOPY (850) 221-5595
www.landandparsons.com

RECEIVED-FPSC
AUG 18 PM 4:22
RECORDING
ND

August 18, 2000

BY HAND DELIVERY

Blanca S. Bayo, Director
Division of Records and Reporting
Florida Public Service Commission
2540 Shumard Oak Boulevard
Tallahassee, Florida 32399-0850

Re: Petition for Determination of Need for the Osprey Energy
Center, FPSC Docket No. 000442-EI

Dear Ms. Bayo:

Enclosed for filing on behalf of Calpine Construction Finance
Company, L.P., are an original and fifteen copies of each of the
following witnesses' testimony and exhibits:

- Michel P. Armand, P.E. - 10169-00
- Ted S. Baldwin - 10170-00
- Gerard J. Kordecki - 10171-00
- Michael Petit - 10172-00
- Richard A. Zwolak, AICP - 10173-00

Calpine will file the testimony and exhibits of its two
remaining witnesses, Timothy R. Eves and Kenneth J. Slater, on
Monday, August 21.

I will appreciate your confirming receipt of this response by
stamping the attached filing copy thereof and returning same to my
attention. As always, thanks to you and your Staff for your
considerate and professional assistance. If you have any
questions, please give me a call.

Cordially yours,



Robert Scheffel Wright

- APP _____
 - CAF _____
 - CMP _____
 - COM 3/09
 - CTR _____
 - ECR _____
 - LEG 2
 - OPC _____
 - PAI _____
 - RGO _____
 - SEC _____
 - SER 1
 - OTH _____
- Enclosures

10169-00

BEFORE THE FLORIDA PUBLIC SERVICE COMMISSION

In Re: Petition for Determination of)
Need for an Electrical Power Plant in) DOCKET NO. 000442-EI
Polk County by Calpine Construction)
Finance Company, L.P.)

DIRECT TESTIMONY AND EXHIBITS

OF

MICHEL P. ARMAND, P.E.

ON BEHALF OF

CALPINE CONSTRUCTION FINANCE
COMPANY, L.P.

DOCUMENT NUMBER DATE

10169 AUG 18 88

FPSC REG. U.S. REPORTING

BEFORE THE FLORIDA PUBLIC SERVICE COMMISSION

IN RE: PETITION FOR DETERMINATION OF NEED FOR AN ELECTRICAL
POWER PLANT IN POLK COUNTY BY CALPINE CONSTRUCTION FINANCE
COMPANY, L.P.
FPSC DOCKET NO. 000442-EI

DIRECT TESTIMONY OF MICHEL P. ARMAND, P.E.

1 Q: Please state your name and business address.

2 A: My name is Michel Armand, and my business address is 3113
3 Lawton Road, The Carr Building, Suite 130, Orlando, Florida
4 32803-3519.

5
6 Q: By whom are you employed and in what position?

7 A: I am employed as a Principal of Navigant Consulting, Inc.
8 (NCI).

9
10 Q: Please describe your duties with NCI.

11 A: I am responsible for conducting transmission planning and
12 operations studies for NCI clients. These studies cover
13 proposed generating plants and their associated transmission
14 interconnections, actual system performance based on projected
15 seasonal loading conditions, and the determination of
16 potential operating constraints necessary to insure reliable
17 operation of the bulk transmission system.

18

19

DOCUMENT NUMBER-DATE

1
10169 AUG 18 88

FPSC-RECORDS/REPORTING

DIRECT TESTIMONY OF MICHEL P. ARMAND, P.E.

QUALIFICATIONS AND EXPERIENCE

1
2
3
4
5
6
7
8
9
10
11
12
13
14
15
16
17
18
19
20
21
22
23
24

Q: Please summarize your educational background and experience.

A: I graduated from the City College of the City University of New York in June 1968, with the degree of Bachelor of Engineering - Electrical. In June 1971, I graduated from the Bernard Baruch College of the City University of New York with the degree of Master of Business Administration.

In 1971, I attended the General Electric Company's one-year course in Advanced Power System Engineering, in Schenectady, New York. In 1978, I attended the one-month Public Utility Executive Program of the Graduate School of Business Administration of the University of Michigan. In 1983, I attended the two-month Executive Program of the Colgate Darden Graduate School of Business Administration of the University of Virginia.

Upon graduation, I was employed by the Consolidated Edison Company of New York. I was assigned to the Distribution Engineering, Station Design, and System Planning Departments. My permanent assignment was in the Transmission Planning Section of the System Planning Department.

In April 1974, I was employed by Florida Power & Light Company (FPL) in the System Planning Department. In April 1976, I was put in charge of the Reliability and System Security Section, responsible for testing and assessing the

DIRECT TESTIMONY OF MICHEL P. ARMAND, P.E.

1 dynamic performance of the planned generation and transmission
2 system, and for making recommendations based on our tests and
3 assessments. In June 1984, I was transferred to FPL's Power
4 Supply Department as Manager of Technical Services responsible
5 for daily analysis of system performance, monitoring the
6 adequacy of performance of transmission protective systems,
7 and coordinating the protection and control settings of FPL's
8 generation, transmission, and distribution systems. In May
9 1991, I became Director of Protection and Control Systems
10 responsible for the design, engineering, installation, and
11 maintenance of all protections and control systems for the
12 generation, transmission, and distribution systems of FPL. In
13 October 1993, I took early retirement from FPL.

14 From December 1994 to December 1996, I was employed as
15 Energy Consultant in the Office of the Prime Minister of
16 Haiti. In 1997, I assumed my present position as Principal
17 Executive Consultant with NCI, formerly Resource Management
18 International, Inc.

19 I am a registered professional engineer in the State of
20 Florida, and I am a member of the Institute of Electrical and
21 Electronic Engineers and a member of the Society of
22 Professional Engineers.

23

24

DIRECT TESTIMONY OF MICHEL P. ARMAND, P.E.

1 Q: What is your experience in power plant engineering,
2 construction, operations, permitting, and licensing?

3 A: As a manager for NCI, I provided transmission planning
4 analyses for Duke Energy Power Services (Duke) in support of
5 a 500 MW plant at New Smyrna Beach, Florida. I was the
6 project manager for this work and prepared testimony in
7 support of Duke's petition to the Florida Public Service
8 Commission. NCI conducted Power Flow Studies to determine the
9 best configuration to integrate a 500 MW power plant into the
10 transmission grid.

11 As Supervisor of Reliability and System Security for
12 Florida Power & Light Company, responsible for modeling the
13 dynamic response of the system to disturbances, I was involved
14 with the Power Plant Engineering Department in specifying the
15 electrical parameters of new generators such as power factor,
16 short circuit ratio, high initial response exciter, power
17 system stabilizer, generator step-up and auxiliary
18 transformers, tap ratio coordination, and switchyard
19 connections. I also initiated studies to add power system
20 stabilizers and modify relay protection schemes for existing
21 high capacity generating units (600 MW and above) on the FPL
22 system.

23 I was heavily involved in the licensing of FPL's St.
24 Lucie Unit No. 2, a nuclear unit. In this activity, I

DIRECT TESTIMONY OF MICHEL P. ARMAND, P.E.

1 participated in the Final Safety Analysis Report for the
2 unit's operating license and testified at the evidentiary
3 hearing in Miami, in November 1979, on the issue of grid
4 reliability.

5
6 **Q: What is your experience in generation planning, transmission
7 planning, transmission design, and load flow studies?**

8 **A:** In my professional work, the size and location of generation
9 was always a given. My responsibility was the integration of
10 the generators in the transmission grid for optimum delivery
11 of the power under all postulated transmission outages.

12 I have extensive professional experience in transmission
13 planning. At Consolidated Edison of New York, I was
14 responsible for transmission planning for the borough of
15 Manhattan, representing at that time about 45 percent of
16 ConEd's total system demand. At FPL, I was responsible for
17 transmission planning in Dade and Broward Counties,
18 representing, at that time, about 60 percent of FPL's total
19 system demand. While not involved in the physical design of
20 transmission lines, studies initiated and conducted by me
21 resulted in the partial transposition of the 500 kV
22 transmission corridor on the East Coast of Florida. The
23 deleterious effects of unbalanced, negative sequence currents
24 on the generators along the corridor were considerably

DIRECT TESTIMONY OF MICHEL P. ARMAND, P.E.

1 reduced.

2 Load flow and transient stability studies were the
3 principal tools used to assess the seasonal, yearly, and long-
4 range performance of the Florida Grid. Such studies were
5 conducted by me and by my section internally for FPL, and in
6 participation with the Florida Electric Power Coordinating
7 Group (FCG). Such tools were also used to update the Florida
8 under-frequency load shedding program and to establish the
9 various remedial action systems on FPL's system to mitigate
10 loss of heavily loaded transmission corridors.

11

12 **Q: Have you previously testified before regulatory authorities or**
13 **courts?**

14 **A:** I have testified before the Atomic Safety and Licensing Appeal
15 Board of the U.S. Nuclear Regulatory Commission, in an
16 evidentiary hearing on the alleged inadequacy of electric
17 power systems for St. Lucie Unit No. 2. The operating license
18 was granted after it was clearly demonstrated that the planned
19 transmission grid would provide adequate and reliable off-site
20 power in an emergency. I have testified before the Florida
21 Public Service Commission in the Duke New Smyrna need
22 determination hearing. I have also testified in court in an
23 eminent domain proceeding for the condemnation of property for
24 transmission line right-of-way.

DIRECT TESTIMONY OF MICHEL P. ARMAND, P.E.

1 Q: Are you a registered professional engineer?

2 A: Yes. I am a registered professional engineer in the State of
3 Florida.

4

5 SUMMARY AND PURPOSE OF TESTIMONY

6 Q: What is the purpose of your testimony?

7 A: I am testifying on behalf of Calpine Construction Finance
8 Company, L.P., (Calpine) for the Commission's determination of
9 need for the Osprey Energy Center (the Osprey Project or the
10 Project). My testimony describes the transmission
11 interconnection facilities that will connect the proposed
12 power plant to the Tampa Electric Company Recker Substation
13 located adjacent to the southeastern boundary of the site. My
14 testimony also presents and describes the load flow analyses
15 that NCI conducted to evaluate the transmission impacts of the
16 Osprey Energy Center under various power delivery scenarios.

17

18 Q: Please summarize your testimony.

19 A: The Osprey Energy Center will be connected to Tampa Electric
20 Company's Recker Substation located adjacent to the
21 southeastern boundary of the Project site. This
22 interconnection, together with some limited transmission
23 upgrades, will enable power from the Project to be delivered
24 to virtually any retail-service utility in Peninsular Florida

DIRECT TESTIMONY OF MICHEL P. ARMAND, P.E.

1 under almost all conditions on the Florida transmission grid.
2 The Project's output will not adversely affect any of the
3 "constrained transmission paths" identified by the Florida
4 Reliability Coordinating Council (FRCC). System impact
5 studies conducted for Calpine included load flow analyses,
6 transient stability analyses, and short circuit analyses.
7 These studies indicate that, under normal operating
8 conditions, that is, with all facilities in service, the
9 Project will not materially burden the transmission system or
10 violate any transmission constraints or contingencies in
11 Peninsular Florida. These studies suggest that some limited
12 upgrades may be needed and those are discussed in detail later
13 in my testimony.

14
15 **Q: Are you sponsoring any exhibits to your testimony?**

16 **A: Yes. I am sponsoring the following exhibits:**

- 17 MPA-1. Qualifications of Michel P. Armand, P.E.
18 MPA-2. Proposed 530 MW Florida Generating Facility, Osprey
19 Energy Center, February 2000; and
20 MPA-3. Analysis of Transmission System Improvements in
21 support of Osprey Energy Center, April 18, 2000;
22 and
23 MPA-4. Regional Transmission Map of West Central Florida.

24

DIRECT TESTIMONY OF MICHEL P. ARMAND, P.E.

1 I am also sponsoring the portions of the Exhibits to the
2 Petition for Determination of Need related to transmission.
3 Specifically, in the Exhibits supporting the Petition, I am
4 sponsoring Figures 11 and 12 as well as the text that
5 accompanies those figures.
6

7 NCI'S ROLE REGARDING THE OSPREY ENERGY CENTER

8 Q: Please describe Navigant Consulting, Inc. and its business.

9 A: Navigant Consulting, Inc. provides comprehensive consulting
10 and engineering services to a wide range of clients, including
11 the electric power industry. NCI provides consulting and
12 engineering services on power system design, power plant
13 design, and transmission and distribution system design and
14 operations.
15

16 Q: What are your responsibilities with respect to the electrical
17 power plant project that is the subject of this proceeding?

18 A: NCI has been retained to evaluate the transmission impacts of
19 the Osprey Energy Center's operation as a power plant selling
20 wholesale power to other utilities that provide retail
21 electric service in Peninsular Florida. I have the primary
22 responsibility for conducting the studies by which we have
23 analyzed the Project's transmission impacts.
24

DIRECT TESTIMONY OF MICHEL P. ARMAND, P.E.

1 Q: With what similar projects has NCI been involved, and in what
2 capacity?

3 A: NCI has conducted numerous evaluations of the load flow
4 impacts of planned and proposed interconnections of generating
5 units, including wholesale power plants, with high-voltage
6 transmission systems, including projects in Oregon, Minnesota,
7 New York, Hawaii, Texas, California, and the East Central Area
8 Reliability (ECAR) Region.

9

10 TRANSMISSION INTERCONNECTION AND ASSOCIATED DOWNSTREAM
11 TRANSMISSION FACILITIES FOR THE OSPREY ENERGY CENTER
12

13 Q: Please describe the transmission facilities by which the
14 Osprey Energy Center will be connected to the Florida
15 transmission grid.

16 A: The Osprey Energy Center Project will be connected to the
17 existing Tampa Electric Company's Recker Substation. The
18 interconnection will include switchgear, circuit breakers, and
19 related equipment appropriate for this type of
20 interconnection.

21

22 Q: How did you and NCI evaluate the capability of the Osprey
23 Energy Center Project to deliver wholesale power to other
24 retail-service utilities in Florida?

DIRECT TESTIMONY OF MICHEL P. ARMAND, P.E.

1 A: We evaluated the transmission system impacts of the Project by
2 conducting power flow studies (also known as load flow studies
3 or load flow analyses) in which we simulated the power flows
4 that would result from sales from the Project to other key
5 utilities in Peninsular Florida. Our power flow studies
6 utilized standard transmission modeling techniques and
7 assumptions. Basically, as discussed in more detail below, we
8 compared the simulated operations of the Florida transmission
9 system with and without the Project's output being delivered
10 to Florida Power & Light Company (FPL), Florida Power
11 Corporation (FPC), Tampa Electric Company (TECO), Jacksonville
12 Electric Authority (JEA), and Seminole Electric Cooperative
13 (Seminole or SEC).

14 We reviewed and utilized the following documents and
15 reports in preparing our power flow studies.

- 16 1. FPL's 1999 Ten-Year Plant Site Plan.
- 17 2. FPC's 1999 Ten-Year Site Plan.
- 18 3. TECO's 1999 Ten-Year Site Plan.
- 19 4. Florida Reliability Coordinating Council (FRCC),
20 1997 Final Transmission System Constraints Maps.
- 21 5. FRCC, 1997 Transfer Capability Study: FLA/SOV
22 Interface.
- 23 6. FRCC, 1999 Reliability Study.

24 We utilized these documents and reports because at the time

DIRECT TESTIMONY OF MICHEL P. ARMAND, P.E.

1 out study was done, the 2000 Ten-Year Site Plans were not
2 available. We used the most current data available.

3
4 Q: What are the relevant import and export capabilities of the
5 transmission interface between Peninsular Florida and the
6 Southeastern Electric Reliability Council (SERC) region?

7 A: Peninsular Florida has the capability of importing
8 approximately 3,600 MW of power from the SERC region, and the
9 capability of exporting approximately 2,100 MW of power to the
10 SERC region. This difference exists because the transmission
11 system in southern Georgia becomes constrained, on a first-
12 order contingency basis, at lower loads than does Peninsular
13 Florida.

14
15 Q: Please summarize the results of the power flow studies you
16 conducted for the Osprey Project.

17 A: The analyses conducted by NCI indicate that at average loading
18 conditions on the Florida transmission system (60% for the
19 rest of the state, 70% for Tampa), no overload occurs for all
20 the contingencies simulated and for all dispatch scenarios.
21 The studies also indicate that in order to support the
22 delivery of wholesale power from the Project to utilities
23 providing retail service in Florida, under eighteen base cases
24 modeled, none of the transmission lines in the vicinity of the

DIRECT TESTIMONY OF MICHEL P. ARMAND, P.E.

1 Osprey Project would be overloaded under normal conditions
2 with all facilities in service. Under summer 2004 peak load,
3 when importing 2400 MW from Southern Company, loss of the
4 Recker-Gapway 230 kV line (a single contingency) causes the
5 Ariana 230/69 kV transformer to load up to 103.8 percent of
6 its emergency rating for all dispatch scenarios. Similarly,
7 loss of the McIntosh-Lake Agnes 230-kV circuit causes the Lake
8 Agnes-Recker 230-kV circuit to load up to 102.6 of its
9 emergency rating when the plant output is scheduled for FPL,
10 FPC, JEA, and SEC. Also, loss of the Griffin-Lakeland West
11 230-kV circuit causes the Osceola-Lake Agnes 230-kV circuit to
12 load up to 100 percent of its emergency rating when the plant
13 output is scheduled to FPC, JEA and SEC.

14 During the summer 2004 peak load period, when importing
15 3600 MW from Georgia, loss of the Recker-Gapway 230-kV circuit
16 causes the Ariana 230/69-kV transformer to load up to 104.6
17 percent of its emergency rating.

18
19 **Q: Did NCI conduct any additional load flow studies?**

20 **A.** Yes. NCI then conducted additional load flow analyses to
21 determine the capacity of the surrounding transmission system
22 to effectively transform and transmit the Project's generated
23 electric power to its customers via the Florida transmission
24 grid. This study, using a single contingency approach,

DIRECT TESTIMONY OF MICHEL P. ARMAND, P.E.

1 identified four critical facilities owned by TECO. Those four
2 critical facilities are the Recker to Lake Agnes 230 kV
3 transmission line, the Recker to Crews Lake 230 kV
4 transmission line, the Crews Lake to Pebbledale 230 kV
5 transmission line, and the 150 MVA, 225Y/130 - 69Y/38.8 kV
6 transformer at Ariana Substation. The analysis conducted by
7 NCI indicates that under maximum loading conditions and single
8 contingency failure of related facilities, the transmission
9 lines interconnecting the Project with the grid should be
10 rated a minimum of 478 MVA. According to TECO, however, the
11 load carrying capacity of the critical transmission lines is
12 398 MVA. The NCI analysis also indicates that under maximum
13 loading conditions and single contingency failure of
14 associated facilities, the transformer at TECO's Ariana
15 Substation would be overloaded to 220 MVA, or 47 percent above
16 its nominal rating of 150 MVA.

17
18 **Q: Please describe any downstream transmission system upgrades**
19 **that may be needed in connection with the Project.**

20 **A: Based on the single contingency load flow studies, NCI has**
21 **identified the following downstream transmission upgrades that**
22 **may be needed:**

- 23 1. Upgrading the conductor and poles on a 1.4-mile section
24 of the Recker to Crews Lake transmission line;

DIRECT TESTIMONY OF MICHEL P. ARMAND, P.E.

- 1 2. Upgrading all conductor on the 6.3-mile Crews Lake to
2 Pebbledale line and upgrading the poles on approximately
3 3.2 miles of that line; and
4 3. Upgrading the transformation capacity at TECO's Ariana
5 Substation, which may include adding cooling capacity to
6 the existing 150 MVA transformer or adding another 150
7 MVA transformer.

8 A map showing the transmission interconnection and the
9 transmission facilities in the Osprey Energy Center area is
10 found at Figure 11 of the Petition for Need Determination
11 Exhibits and is included here as MPA-4.

12

13 **Q: Did you evaluate the Project's capability to deliver power**
14 **outside Florida?**

15 A: No. I understand that Calpine's intent is to sell wholesale
16 power from the Project within Peninsular Florida, and
17 accordingly, NCI was not asked to perform any power flow
18 studies for sales outside Peninsular Florida.

19

20 **Q: Are you aware of any other transmission studies that have been**
21 **done for the Project?**

22 A: Yes. TECO performed a preliminary transmission service
23 request facilities study and provided a draft to Calpine on
24 May 22, 2000. TECO's study considered double second-order

DIRECT TESTIMONY OF MICHEL P. ARMAND, P.E.

1 contingencies as well as first single-order contingencies and
2 was therefore more restrictive than NCI's studies. TECO's
3 study also had no cost information related to its suggested
4 upgrades.

5
6 **Q: What did TECO recommend?**

7 **A:** Under a second contingency scenario, TECO recommended a new
8 Recker-South Eloise 230-kV line, 10.6 miles of new 230kV pole
9 line and five new breakers, creating a loop from the North
10 Bartow-West Lake Wales line through South Eloise, splitting
11 the line up into two 2-terminal 230kV circuits: North Bartow
12 to South Eloise and West Lake Wales to South Eloise.

13
14 **Q: Does the TECO study alter your opinion?**

15 **A:** No. I stand by my analysis which assumes that under a single
16 contingency and NCI's proposed modifications, the plant output
17 can be delivered without causing undue burden on the Florida
18 Transmission Grid. However, the TECO proposal is also
19 supportable since it postulates a double contingency scenario
20 and an appropriate solution.

21
22 **Q: How will the actual transmission system upgrades be decided?**

23 **A:** Calpine and TECO will reach an appropriate solution under
24 TECO's Open Access Transmission Tariff. Regardless which

DIRECT TESTIMONY OF MICHEL P. ARMAND, P.E.

1 package of upgrades is implemented, the transmission system,
2 will support delivery of Osprey Project power to any other
3 utility in Peninsular Florida without materially burdening the
4 transmission grid and without causing any violation of any
5 constraints or contingencies in the grid. Calpine is fully
6 prepared to do what it must to support delivery of its full
7 output to any utility in Peninsular Florida. The details will
8 be a matter to be negotiated between Calpine and TECO pursuant
9 to TECO's tariff.

10

11 Q: Does this conclude your direct testimony?

12 A: Yes, it does.

BEFORE THE FLORIDA PUBLIC SERVICE COMMISSION

In Re: Petition for Determination of)
Need for an Electrical Power Plant in) DOCKET NO. 000442-EI
Polk County by Calpine Construction)
Finance Company, L.P.)

EXHIBITS

OF

MICHEL P. ARMAND, P.E.

ON BEHALF OF

**CALPINE CONSTRUCTION FINANCE
COMPANY, L.P.**

MICHEL P. ARMAND

Michel Armand is a Senior Engagement Manager in the Transmission Planning sub-practice area of Navigant Consulting, Inc. He has 33 years of utility experience in transmission and distribution planning and engineering both in New York and in Florida. He has conducted numerous studies in the area of transmission reliability and network security, and is extremely knowledgeable of the Florida transmission system. He has expertise in managing corporate staff involved in load flow, short circuit and transient stability studies, including the determination of operating limits, the development of remedial action schemes, and the development of methods to assess system-wide losses. In addition, he has testified before the Nuclear Regulatory Commission (NRC) and various state courts in condemnation hearings, and in Florida PSC power plant 'NEED' hearings. He was involved in restructuring and privatization studies of the State Utility Company as Energy Advisor to the Prime Minister of Haiti. He has consulted with the Transmission Agency of Northern California, the Bonneville Power Administration and the California ISO in assessing Operating Transfer Capabilities (OTC) for spring and summer across the California Oregon Interconnection (COI). Mr. Armand has also performed numerous transmission system impact assessment for merchant power projects in Texas, California and Florida.

EDUCATION

MBA - Baruch College of the City University of New York
New York

BEE - City College of the City University of New York
New York

BA - College St. Martial
Port-Au-Prince, Haiti

PROFESSIONAL HISTORY

Navigant Consulting, Inc. formerly Resource Management International, Inc.
Manager

Government of Haiti
Energy Consultant - Prime Minister's Office

Florida Power & Light Company
Director, Protection and Control Systems

Consolidated Edison Company of New York
Senior Engineer

REPRESENTATIVE PROJECT EXPERIENCE

Duke Energy Power Services. 1998
Duke Energy Power Services retained NCI to provide transmission planning analyses in support of a 500Mw plant at New Smyrna Beach in Florida. Duke also requested that NCI prepare testimony in support of their petition to the Florida Public Service Commission for a Determination of Need for power plants. Michel Armand was project manager for this work and prepared the resulting testimony. NCI conducted Power Flow Studies to determine the best configuration to integrate a 500Mw power plant in the vicinity of New Smyrna Beach, Florida. NCI also prepared and filed testimony in support of Duke's Needs Petition Hearing before the Florida Public Service Commission.

St. Lucie Nuclear Unit No. 2 - Regulatory Licensing. Florida Power and Light Company. Miami, Florida. 1979

As Supervisor of Reliability and System Security for Florida Power and Light Company (FPL), responsible for testing and assessing the dynamic performance of the planned generation and transmission system, I was called to testify about the ability of the system to support the addition of a second nuclear unit at St. Lucie Power Station. In testimony before the NRC Atomic Safety and Licensing Appeal Board, the adequacy of the transmission grid was demonstrated and the operating license was subsequently granted.

500 kV Interconnection with Georgia. Florida Power and Light Company. Miami, Florida. 1980

As Supervisor of Reliability in the System Planning Department at Florida Power and Light Company (FPL), and member of the 500 kV project team, performed the evaluations necessary to justify the construction of two 500 kV lines from the Georgia state line in the north to a point 310 miles south. Wrote testimony in support of the economic and reliability benefits of the lines in proceedings of the Florida Transmission Line Siting Act before the Public Service Commission and the State Cabinet. Conducted technical studies to define the line parameter, the ancillary equipment and the termination of various segments of the project. Given the considerable benefits of reducing oil consumption in favor of coal, the project was given accelerated depreciation privileges for rate making purposes.

Breaker Duty Evaluation Program. Florida Power and Light Company. Miami, Florida. 1981

As Project Manager, oversaw the definition, design, development, testing, and implementation of an automated system to evaluate the adequacy of transmission circuit breakers on the Florida Light and Power (FPL) system. Coordinated the work of equipment specialists, computer programmers and systems planners to arrive at a program which consistently and accurately performs the many calculations required. The very serious potential for human errors was practically eliminated, and these long lead items could be ordered within reasonable schedules.

Audit of Energy Reduction Marketing Program. Florida Power and Light Company. Miami, Florida. 1983

As auditor, performed an independent assessment of the various marketing product offerings and determined their effectiveness in achieving the goals of the demand side programs. Recommended a market segmentation approach where the effectiveness of specific programs was shown to be related to the four distinct weather regions of Florida. Also provided valuable insight to the marketing team on the behavior of the load during

winter and summer, i.e., pool pumps, an 800 MW load then, were rescheduled to different time slots to avoid the early morning peak in the winter and the late afternoon peak in the summer.

Economic Evaluation of Power Generation Asset. Florida Power and Light Company. Miami, Florida. 1984

As Project Manager, conducted examination of options available to determine final disposition of questionable assets. The asset could be kept in use, put into long-term reserve shut down, retired, or sold. Taking into account the various interests of the operating groups, recommendation was made to choose the long-term reserve shut down as the most attractive option financially, from a capacity addition standpoint, and from considerations of system adequacy and reliability.

Analysis of Electric System Losses. Florida Power and Light Company. Miami, Florida. 1984

As lead investigator, I was charged with a determination of accounting for losses on the Florida Power and Light (FPL) system. As the system was experiencing rapid growth, economic decisions to select among alternative proposals were based on crude assumptions regarding system losses. Electric power system losses in the United States run into the billions of dollars each year. Selection among competing alternatives could sometimes be made on the basis of their contribution to reducing system losses. Over a three month period, all the departments having an impact were visited, huge amounts of data collected, tens of employees interviewed and, finally, one document produced. In it, for the first time in one document, the issue of system losses was addressed in all its major components, and its myriad of implications. The report is still used today as a reference document in any effort to reduce system losses in a systematic fashion.

Blackout Prevention by Automated Fast Action. Florida Power and Light Company. Miami, Florida. 1985

As Manager, Power Supply Technical Services, was charged with recommending programs and actions to prevent another blackout similar to the one on May 17, 1985, which put the Greater Miami, Ft. Lauderdale area in the dark for three hours. The result was a computer program that monitors the system for specific conditions and takes remedial action within a 15-20 second time window. Severe economic penalties were incurred until this system went in place and economic dispatch was resumed. The same concept was replicated in another part of the system providing additional economic benefit.

Transmission Outage Data Base. Florida Power and Light Company. Miami, Florida. 1989

As Project Manager, was tasked with the charge of researching, developing, and implementing a transmission outage data base system.

MICHEL P. ARMAND

The purpose was to collect information in such a way that it could be stored, analyzed, categorized, and utilized by many departments involved in the designing, engineering, construction, and operation of the transmission system. The task involved the collection of valid requirements from all concerned parties, the resolution of conflicting demands and, finally, securing agreement on analysis and categorization of data covering the prior period of 1983 to 1987. The information proved invaluable to the system operators, transmission maintenance personnel and the transmission design and engineering staff. Unexpected results of this effort: the data was also used to show potential industrial customers the reliability of a particular transmission line (since data went back to 1983); used in court proceedings dealing with the issue of power quality; and used in regulatory hearings dealing with needed new transmission corridors.

Privatization Strategy for Haiti Electric Utility. Prime Minister Office - Government of Haiti. Port-Au-Prince, Haiti. 1996

As Energy Advisor in the office of the Prime Minister, responsible for developing and recommending options to restructure the state owned utility.

In the framework of privatization of money-losing state enterprises, I evaluated various options: restructuring and improving operations as an independent commercial operation owned by the state; contract with a foreign entity for the management and operation within a fixed time period; lease the assets and the franchise for a 25-30 year period with the assets plus additions reverting the state at contract expiration; and an outright sale to private investors, local and/or foreign. Each option was evaluated based on economic, financial, and political risk considerations, and presented to the cabinet. The lease option was selected as the final objective preceded by a five-year management contract to increase the value of the assets and the lease. Parliament approved the concept and laws are being passed or modified to allow the state and the operator to achieve their objective.

**PROFESSIONAL
MEMBERSHIPS**

Society of Professional Engineers
Institute of Electrical & Electronic Engineers

**PROPOSED 530 MW FLORIDA
GENERATING FACILITY
OSPREY ENERGY CENTER**

Prepared For

CALPINE EASTERN CORPORATION

UNPUBLISHED WORK © FEBRUARY 2000



Navigant™



CONFIDENTIAL

March 1, 2000

VIA FEDERAL EXPRESS

Mr. Paul A. Barnett
Director - Asset Optimization
Calpine Eastern Corporation
The Pilot House, 2nd Floor
Lewis Wharf
Boston, MA 02110

Subject: Transmission System Analysis in Support of
Calpine Eastern Corporation Osprey Energy Center

Dear Paul:

Enclosed are four copies of the subject report prepared in accordance with our agreement with Calpine Eastern Corporation.

The starting point for this study is the year 2004 summer peak case filed with the Federal Energy Regulatory Commission (FERC) by the Florida Reliability Coordinating Council (FRCC), fiscal year 1998, Revision 5. This base case was obtained from the FERC-1999 Form 715 Regional Power Flow Cases and Transmission Planning Reports, Website updated 10/12/1999.

The FRCC case submitted to FERC was carefully reviewed, and the data on generation resources was compared to the individual utility Ten Year Site Plans filed with the Florida Public Service Commission. Although several merchant plants have been announced, some requiring a Need Determination approval and some not, none were represented in the base cases. Only generation containing the Official Ten Year Site Plans were represented and dispatched if needed.

The transmission system was scrutinized, especially around the projected site for the Osprey Energy Center. Except for some minor transmission inconsistencies in the FPL system, there appears to be no wholesale tampering with the representation of the Florida transmission system.

Mr. Paul A. Barnett
March 1, 2000
Page Two

Therefore, the powerflow studies discussed in the enclosed report evaluated:

- Pre- and post-project transmission system performance for the year 2004, when the Florida system experiences peak loading conditions and imports 3,600 MW of power from Georgia.
- Pre- and post-project transmission system performance for the year 2004 when the Florida system is at peak load and imports 2,400 MW of power from Georgia.
- Pre- and post-project transmission system performance for the year 2004 when the Florida system is loaded to 60% of summer peak load and imports 2,400 MW of power from Georgia. This load level is considered the average loading of the Florida system.

Based on the studies discussed in the enclosed report, it appear that:

1. The proposed 530 MW Osprey Energy can reliably deliver its output into the Florida Transmission System.
2. Some minor overloads, at peak and at peak import, following certain system element outages, can be resolved by either system upgrade or reduction in plant output.
3. At average load conditions, 60% of summer peak, no overloaded facility was uncovered under all dispatch scenarios modeled and outages simulated.

We look forward to discussing the enclosed report with you, at your convenience. In the interim, please call me at (407) 895-7000 should you have any questions on the enclosed.

Sincerely,

Michel P. Armand / lcb

Michel P. Armand
Manager



PROPOSED 530 MW FLORIDA GENERATING FACILITY

OSPREY ENERGY CENTER

Prepared For

CALPINE EASTERN CORPORATION

Prepared By



Navigant[™]
CONSULTING, INC.

UNPUBLISHED WORK © MARCH 2000

CALPINE EASTERN CORPORATION
PROPOSED 530 NW OSPREY ENERGY CENTER
RESULTS OF POWERFLOW STUDIES - 2004

SECTION 1

EXECUTIVE SUMMARY

Calpine Eastern Corporation (Calpine) is proposing to build a 530 MW merchant plant facility in Florida. The facility will be sited in Polk County at the Recker Substation of Tampa Electric Company, and is projected to begin commercial operation before the summer of 2004. Calpine retained Navigant Consulting, Inc. (Navigant Consulting) to assist them in evaluating the interconnection of the proposed Osprey Energy Center (OEC) project with the Florida transmission network.

In providing this support, Navigant Consulting performed a series of preliminary power flow studies evaluating:

- Summer 2004 transmission system performance at peak load, importing 3600 MW from the Southern Company, with and without the Osprey Energy Center project.
- Summer 2004 transmission system performance at peak load, importing 2400 MW from the Southern Company, with and without the Osprey Energy Center project.
- Summer 2004 transmission system performance at an average 60% of peak load (70% of peak for TECO), importing 2400 MW from the Southern Company, with and without the Osprey Energy Center project.

To determine the ability of the project to deliver its output over the Florida transmission system, the total capacity of the plant (530 MW) was scheduled alternatively to Florida Power and Light Company (FPL), Florida Power Corporation (FPC), Tampa Electric Company (TEC), Jacksonville Electric Authority (JEA), and Seminole Electric Cooperative (SEC). Each of these dispatch scenarios was modeled and tested with the three base cases.

In summary, these studies (which are summarized in Table 1-1 and discussed in detail in Sections 2 and 3, show that for the conditions modeled:

1. None of the lines in the vicinity of the proposed Osprey Energy Center were overloaded in the eighteen base cases that were developed for these studies, and which model system normal conditions (all facilities in service).
2. During the summer 2004 peak load period, when importing 2400 MW from Southern, loss of the Recker-Gapway 230-kV line causes the Ariana 230/69-kV transformer to load up the 103.8 percent of its emergency rating for all dispatch scenarios. Similarly, loss of the McIntosh-Lake Agnes 230-kV circuit causes the

Lake Agnes-Recker 230-kV circuit to load up the 102.6 percent of its emergency rating when the plant output is scheduled to FPL, FPC, JEA, and SEC. Also, loss of the Griffin-Lakeland West 230-kV circuit causes the Osceola-Lake Agnes 230-kV circuit to load up to its emergency rating when the plant output is scheduled to FPC, JEA, and SEC.

3. During the summer 2004 peak load period, when importing 3600 MW from Georgia, loss of the Recker-Gapway 230-kV circuit causes the Ariana 230/69-kV transformer to load up to 104.6 percent of its emergency rating.
4. At average loading conditions on the Florida transmission system (60% for the rest of the state, 70% for Tampa), no overload is noticed for all the contingencies simulated and for all dispatch scenarios.

Therefore, based on the preliminary studies discussed in this report, it appears that:

1. 530 MW can be reliably sited at the Osprey Energy Center.
2. The output of the plant can be delivered without imposing undue burden on the Florida transmission system. System upgrade considerations must be weighted against reducing plant output following the specific contingencies which could cause overloads.

**TABLE 1-1
SUMMARY OF POWERFLOW BASE CASES EVALUATED**

Year	Case	Georgia Imports (MW)	OEC* Generation (MW)	Output Delivered to:
2004	2004.PI	3,600	- 0 -	N/A
	2004.PIa	3,600	530	Florida Power & Light
	2004.PIb	3,600	530	Florida Power Corporation
	2004.PIc	3,600	530	Tampa Electric Company
	2004.PId	3,600	530	Jacksonville Electric Authority
	2004.PIe	3,600	530	Seminole Electric Cooperative
2004	2004.	2,400	- 0 -	N/A
	2004.a	2,400	530	Florida Power & Light
	2004.b	2,400	530	Florida Power Corporation
	2004.c	2,400	530	Tampa Electric Company
	2004.d	2,400	530	Jacksonville Electric Authority
	2004.e	2,400	530	Seminole Electric Cooperative
2004	2004-60	2,400	- 0 -	N/A
	2004-60a	2,400	530	Florida Power & Light
	2004-60b	2,400	530	Florida Power Corporation
	2004-60c	2,400	530	Tampa Electric Company
	2004-60d	2,400	500	Jacksonville Electric Authority
	2004-60e	2,400	530	Seminole Electric Cooperative

* Osprey Energy Center

As discussed in Section 2 (Results of Power Flow Studies), each of the cases summarized in Table 1-1 were used as a starting point in evaluating system performance under both normal and single facility (line or generator) – (N-1) outage conditions.

Documents reviewed and utilized by Navigant Consulting during these studies included:

- FPL's *1999 Ten Year Plant Site Plan*
- FPC's *1999 Ten Year Site Plan*
- TEC's *1999 Ten Year Site Plan*
- FRCC's *1997 Final Transmission System Constraints Maps*
- FRCC's *1997 Transfer Capability Study: FLA/SOV Interface*
- FRCC's *1999 Reliability Study*

The powerflow base cases used in these studies were based on the 2004 Summer Base Case filed with FERC by the Florida Reliability Coordinating Council (FRCC), FY1998, Revision 5. This FRCC case was reviewed and compared to the Ten Year Site Plans of FPL, FPC, TEC, JEA, and SEC.

Case 2004.PI was obtained by increasing the import from Georgia to 3600 MW and reducing FPL generation in the south end by 1,200 MW. All loads were maintained at peak summer level.

Case 2004-60 was obtained by scaling loads in Florida to represent 60% of summer peak (except for Tampa, where the average load level is 70% of summer peak). Generation in Florida was re-dispatched for each control area. Import from the Southern Company was maintained and interchange schedules were modified.

SECTION 2

SECTION 2

POWERFLOW BASE CASE DEVELOPMENT

As noted in the Executive Summary, the powerflow base cases used in these studies were based on the 2004 summer peak case filed with FERC by the Florida Reliability Coordinating Council (FRCC), fiscal year 1998, Revision 5. This powerflow case represented the system in peninsular Florida as consisting of nineteen control areas with a combined load of approximately 39,860 MW, and on-line generation of approximately 38,520 MW (both utility and non-utility). Interchange into Florida was approximately 2400 MW and Florida system losses were around 1000 MW. The nineteen control areas and the load and generation represented in each, are summarized in Table 2-1.

Control Area	Load (MW)	Generation (MW)
FPL	19,544	16,471
FPC	9,834	7,782
Fort Pierce	113	63
Gainesville	438	430
Homestead	62	35
Jacksonville	2,825	3,121
Key West	128	0
Kissimmee	277	392
Lake Worth	85	56
New Smyrna Beach	80	18
Orlando	1,129	1,328
Seminole	318	2,804
Lakeland	601	1,070
City of Starke	16	0
Tallahassee	555	558
Tampa	3,522	3,986
FMPA	152	150
Cedar Bay	0	251
Reedy Creek	182	0

The FRCC case submitted to FERC was carefully reviewed and the data on generation resources was compared to the individual utility Ten Year Site plans filed with the Florida Public Service Commission. Although several merchant plants have been announced, some requiring a Need Determination approval and some not, none were represented in the base cases. Only generation contained the Official Ten Year Site Plans were represented and dispatched if needed.

The transmission system was scrutinized, especially around the projected site for the Osprey Energy Center. Except for some minor transmission inconsistencies in the FPL system, there appears to be no wholesale tampering with the representation of the Florida transmission system.

The result of these efforts was acceptance of the FERC-2004 Summer Base Case, FY1998, Revision 5, as a legitimate starting point for the evaluation, based on the load and resource characteristics summarized in Table 2-2. The Osprey Energy Center generation was added to the base case and was integrated at the Recker Substation bus. This case was labeled 2004.sav.

Case 2004.PI.sav was derived by increasing the import in case 2004.sav to 3600 MW. This was accomplished by increasing generation in Georgia by slightly over 1200 MW, and decreasing FPL generation at Turkey Point and Port Everglades by approximately 1200 MW. Cape Canaveral No. 2, the FPL swing generator, was adjusted to provide the additional capacity required.

Case 2004-60.sav was derived by modifying the base case, 2004.sav, to represent loading conditions of 60% of peak, except for Tampa, which was represented at 70%. The 60% load level is considered average loading of the Florida system, and represents a considerable portion of the load duration curve for Florida. Therefore, this load level has always been the benchmark of all transmission assessment studies by powerflow or by transient stability conducted by the PRCC. To achieve such reduction, the load in each control area was scaled down to sixty percent. The total generation required for each area was calculated by adding load, plus generation, plus interchange, and then re-dispatching each area by the removal of appropriate generating units to achieve total required generation. There were a few exceptions.

TABLE 2-2
2004 - Base Case
FY 1998 - Revision 5
Peak Load 2400 MW Import

LOAD, LOSSES, INTERCHANGE, AND GENERATIONS MODELED				
Control Area	Load	Losses	Interchange	Generation
1 FPL	19,544	475	-3,548	16,471
2 FPC	9,834	258	-2,310	7,782
3 Ft. Pierce	113	1	-51	63
4 GVL	438	5	-13	430
5 HST	62	0	-27	35
6 JEA	2,825	52	244	3,121
7 KEY	128	6	-134	0
8 KIS	277	8	107	392
9 LWU	85	0	-29	56
10 NSB	80	0	-62	18
11 OUC	1,129	24	175	1,328
12 SEC	318	52	2,434	2,804
13 LAK	601	7	462	1,070
14 STK	16	0	-16	0
15 TAL	555	14	-11	558
16 TEC	3,522	93	371	3,986
17 FMP	152	2	-4	150
18 NUG	0	1	250.0	251
19 RCU	182	1	-183	0

SECTION 3 RESULTS OF POWER FLOW STUDIES

As discussed in Section 2, three base cases: 2004.PI.sav, 2004.sav, and 2004-60.sav, were developed as a starting point. These three base cases had the proposed Osprey Energy Center at 0 MW. Next, five individual dispatches were established as follows:

- a) Simulated all the plant output being delivered to FPL;
- b) Simulated all the plant output being delivered to FPC;
- c) Simulated all the plant output being sold to TEC;
- d) Simulated all the plant output being delivered to JEA; and
- e) Simulated all the plant output being delivered to SEC.

In all, eighteen base cases (summarized in Table 3-1) were developed in order to evaluate the effects of the proposed 530 MW Osprey Energy Center on the performance of the Florida system. Each of these eighteen cases, summarized in Table 3-1, were used as a starting point in evaluating system performance under normal conditions by comparing pre- and post-project powerflows over key lines and equipment in the proximity of the plant and over certain facilities monitored in past FRCC transmission studies.

In addition, thirty-five (35) single line or generator outages (N-1) were simulated on all the eighteen base cases to assess performance under other than normal conditions. Navigant Consulting also monitored flows over twelve of the thirteen constrained transmission paths discussed in the FRCC 1997 Final Transmission System Constraint Maps. Table 3-2 is a list of the single outages simulated on each of the eighteen base cases. Table 3-3 is a tabulation of the FRCC constrained paths and the transmission circuits affected. Constrained paths #15 and #16 are the Stanton-Rio Pinar 230-kV line. Because the studies performed represent summer season peak load conditions, and, therefore, power transfer from Georgia to Florida, Constraint #13 (which deals with flows from Florida to Georgia) was not checked. Appendix IV is a summary of total constrained path flows in graphic and tabular form, representing the pre- and post-project performance for the 18 base cases.

The contingencies listed in Table 3-2 represent a broad array of outages throughout the Florida system designed to test any negative impact this new plant may have. Some of the outages selected are similar to those selected for past FRCC transmission assessment studies. Some are not expected to be impacted by the new plant; others could potentially be influenced by whether the plant output is scheduled to different receiving parties. In all cases, the most pessimistic conditions were modeled.

The circuits monitored, as shown in Table 3-4, represent all facilities around the plant

location that could experience loading problems, as well as some circuits that have shown a tendency in past FRCC studies to exhibit thermal loading problems.

2004.PI CASES

The result of these cases, representing summer peak loading in Florida and peak import of 3600 MW from Georgia, are summarized in Appendix I, which presents information about the lines monitored, the specific outage, the pre-project conditions, and the five dispatch scenarios; i.e., the plant output respectively delivered to FPL, FPC, TEC, JEA, and SEC.

The analysis reveals that when the Recker to Gapway 230-kV circuit is out of service, the Ariana 230/69-kV autotransformer loads up to:

- 104.6 percent of its emergency rating when the plant output is dispatched to TEC,
- 104.2 percent when the output is sent to FPL,
- 103.9 percent when the output is dispatched to FPC, and
- 103.8 percent when the output is sent to either JEA or SEC.

Also, under peak import conditions and for the specific control area dispatches simulated, loss of the Manatee-Big Bend 230-kV circuit, causes the Buckeye-Ruskin Metering section of the Big Bend-Johnson 230-kV circuit to reach 100.8 percent of its thermal rating. This loading is highly dependent on actual generation at Manatee, and is not an unusual occurrence.

The distribution of flows over the various lines emanating from the Recker Substation for the various dispatch scenarios are shown in Appendix I-A.

2004. CASES

The results of these cases representing summer peak loading in Florida, and an import of 2400 MW, are summarized in Appendix II, which presents information about the lines monitored, the specific outage, the pre-project conditions, and the five dispatch scenarios, i.e., the plant output respectively delivered to FPL, FPC, TEC, JEA, and SEC.

The analysis reveals again that when the Recker to Gapway 230-kV circuit is out of service, the Ariana 230/69-kV exceeds its rated thermal limit:

- 103.8 percent of its emergency rating when the plant output is dispatched to TEC,
- 103.4 percent when the plant output is dispatched to FPL,
- 103.1 percent when the plant output is dispatched to either FPC or JEA, and
- 103 percent when the output is dispatched to SEC.

Also, when the McIntosh-Lake Agnes 230-kV circuit is out of service under peak load conditions, the Recker-Lake Agnes 230-kV circuit experiences loading around 103 percent of its emergency rating when the plant output is dispatched to FPC, JEA, and SEC, and loading of 100 percent of its emergency rating when the output is dispatched to FPL. However, loading is within limits when the output is dispatched to TEC.

When the 230-kV circuit Griffin-Lakeland West is out of service, the Osceola-Lake Agnes 230-kV circuit reaches its emergency thermal rating when the plant output is dispatched to either FPC, JEA, or SEC. When the output is dispatched to FPL or TEC, the line loading is below its emergency thermal rating. Appendix II-A shows the distribution of flows over the various lines emanating from the Recker Substation for the various dispatch scenarios.

2004-60 CASES

The results of these cases representing 60% of summer peak loading in Florida, and an import of 2400 MW from Georgia are summarized in Appendix III, which presents information about the lines monitored, the specific outage, the pre-project conditions, and the five dispatch scenarios; i.e., the plant output respectively delivered to FPL, FPC, TEC, JEA, and SEC.

The analysis reveals that for all the scenarios and all the contingencies simulated, no monitored lines in the proximity of the plant or around the system reached their thermal limits. Since the 60% load level represents the average loading of the Florida system, it appears that the proposed plant can be dispatched most of the time. Appendix III-A shows the distribution of flows over the various lines coming out of the plant for the various dispatch scenarios.

TABLE 3-1
SUMMARY OF POWERFLOW BASE CASES EVALUATED

Year	Case	Georgia Imports (MW)	OEC * Generation (MW)	Output Delivered to:
2004	2004.PI	3,600	- 0 -	N/A
	2004.PIa	3,600	530	Florida Power & Light
	2004.PIb	3,600	530	Florida Power Corporation
	2004.PIc	3,600	530	Tampa Electric Company
	2004.PId	3,600	530	Jacksonville Electric Authority
	2004.PIe	3,600	530	Seminole Electric Cooperative
2004	2004.	2,400	- 0 -	N/A
	2004.a	2,400	530	Florida Power & Light
	2004.b	2,400	530	Florida Power Corporation
	2004.c	2,400	530	Tampa Electric Company
	2004.d	2,400	530	Jacksonville Electric Authority
	2004.e	2,400	530	Seminole Electric Cooperative
2004	2004-60	2,400	- 0 -	N/A
	2004-60a	2,400	530	Florida Power & Light
	2004-60b	2,400	530	Florida Power Corporation
	2004-60c	2,400	530	Tampa Electric Company
	2004-60d	2,400	530	Jacksonville Electric Authority
	2004-60e	2,400	530	Seminole Electric Cooperative

* OEC = Osprey Energy Center

Outage #	Bus 1	kV	Bus 2	kV	CKT
1	Osceola	230	OUCCITP2	230	1
2	Osceola	230	LKAGNES	230	1
3	Osceloa	69	Studio	69	1
4	Sheld	230	LK TARPON	230	1
5	Ruskin T	230	Manatee	230	1
6	RUSKMTR8	230	Buckeye	230	1
7	B Bend	230	Manatee	230	1
8	PEBB	230	Barcola	230	1
9	PEBB	230	N Bartow	230	1
10	PEBB	230	CREWSLK	230	1
11	HARDESUB	230	CC Plant	230	1
12	Recker	230	CREWSLK	230	1
13	Recker	230	LKAGNES	230	1
14	Selose T	230	N Bartow	230	1
15	Selose T	230	Wik Wale	230	1
16	Recker	230	Gapway	230	1
17	Eaton Pk	230	TENOROC	230	1
18	Eaton Pk	230	CREWSLK	230	1
19	TENOROC	230	I-State	230	1
20	West	230	I-State	230	1
21	TENOROC	230	McIntosh	230	1
22	LKAGNES	230	McIntosh	230	1
23	West	230	Barcola	230	1
24	West	230	Griffin	230	1
25	Sheld	230	Sheld-NW	69	1
26	Sheld	230	Sheld-SE	69	1
27	Camp LK	230	Cent Fla	230	1
28	IND RIV	230	Stanton	230	1
29	Curry FD	230	Stanton	230	1
30	BRKRIDGE	500	CRYST RV	500	1
31	Kathleen	500	Cent Fla	500	1
32	Martin 1	22	814 MW	Gen	1
33	Manatee 1	22	783 MW	Gen	1
34	Gannon 6	22	362 MW	Gen	1
35	B Bend4	22	439 MW	Gen	1

TABLE 3-3
LIST OF CONSTRAINED PATHS IN FLORIDA

Const. Number	Constrained Path Name	Transmission Lines Involved
5	Lake Tarpon - Sheldon	Three Lake Tarpon-Sheldon: 230-kV lines.
6	Central-South East	Poinsett-Martin & Poinsett-Midway: 500-kV Lines Malabar-Midway & Malabar-Emerson: 230-kV Lines Malabar-West: 138-kV Line
7	Central-South	Ruskin-Manatee: 230-kV Line Big Bend-Manatee: 230-kV Line Big Bend-Ruskin: 230-kV Line
8	Northwest-Central	2 Silver Spring North-Silver Springs: 230-kv Line
9	Brookridge-South	Brookridge-Lake Tarpon: 500-kV Line Brookridge-Brooksville West: 230-kV Line Brookridge-Hudson: 230-kV Line
10	Northeast-Central	Duval-Poinsett & Rice-Poinsett: 500-kV Lines Putnam-Volusia & Bunnell-Volusia: 230-kV Lines
11	Sylvan-North Longwood	Sylvan-North Longwood: 230-kV Line
12	Georgia-Florida	Hatch-Duval & Thalman-Duval: 500-kV Lines Pine Grove-Suwannee & Kingsland-Yulee: 230-kV Lines South Bainbridge-Tallahassee (sub 20): 230-kV Line Callaway-Port St. Joe: 230-kV Line Pine Grove-Jasper, Tarver-Jasper: 115-kV Line Scholtz-Woodruff: 115-kV Line Twin Lake-Suwannee Pl: 115-kV Line
13	Florida-Georgia	Same as 12 (flows reversed)
14	Crystal River-South	Crystal River-Brookridge: 500-kV Line CR Plant-Brookridge: 230-kV Line CR Plant-Cryst RE: 230-kV Line
15	Cape Canaveral-Indian River	Cape Canaveral-Indian River: 230-kV Line
16	Indian River-Cape Canaveral	Indian River-Cape Canaveral: 230-kV Line
17	Stanton-Central Florida	Stanton-Rio Pinar: 230-kV Line

TABLE 3-4 MONITORED BRANCHES					
Bus 1	kV 1	Bus 2	kV 2	CKT	Area
SN Plant	230	Sylvan	230	1	1
Sylvan	230	N Longwd	230	1	1
Ind Riv	230	Stanton	230	1	11
Buckeye	230	Ruskmtr8	230	1	1
Silvr SP	230	Silv Spn	230	1	2
Silvr SP	230	Ocala 1	230	1	2
Rio Pirr	230	Curry FD	230	1	2
Stanton	230	Curry FD	230	1	11
Osceola	230	LkAgnes	230	1	16
Sheld	230	Lk Tarpon	230	1	2
Pebb	230	Crewslk	230	1	16
Pebb	230	N Bartow	230	1	16
Recker	230	LkAgnes	230	1	16
Recker	230	Ariana	230	1	16
Recker	230	Crewslk	230	1	16
B Bend	230	Manatee	230	1	1
Ruskin	230	Manatee	230	1	1
Ind Riv	230	Ind Riv	115	1	11
Sheld	230	Sheld-NW	69	1	16
Largo	230	Largo A	69	1	2
CLMT EST	230	CLMT EST	69	1	16
Eleven W	230	Eleven-E	69	1	16
Winderme	230	Winderme	69	1	2
Pasadena	230	Pasadena	115	1	2
Ariana	230	Ariana N	69	1	16
Selose	230	Selose N	69	1	16
Gapway	230	Gapway	69	1	16
Crewslk	230	Crewslk	69	1	13
Tenoroc	230	Tenoroc	69	1	13
Barcola	230	West	230	1	13
Eaton Pk	230	Crewslk	230	1	13
Eaton Pk	230	Eaton Pk	69	1	13
Eaton Pk	230	Tenorock	230	1	13
Recker	230	Gapway	230	1	16
SN Plant	115	Turner	115	1	1

APPENDIX I

Table II
Comparison of Line & Transformer Flows
Following N-1 Disturbances
for Various OEC 500 MW Generation Alternatives

100% Load Base Case

All Flows above 100% of Emergency rating are Shown

Monitored Branches							Case 2004PI Base No OEC Gen	Case 2004PIA Sell to FPL	Case 2004PIB Sell to FPC	Case 2004PIC Sell to TEC	Case 2004PID Sell to JEA	Case 2004PIE Sell to SEM
Case#	Bus 1	KV 1	Bus 2	KV 2	ckt	Area	Percent	Percent	Percent	Percent	Percent	Percent
2004PI-1	SN PLANT	230	SYLVAN	230	1	1						
2004PI-1	SYLVAN	230	N LONGWD	230	1	1						
2004PI-1	IND RIV	230	STANTON	230	1	11						
2004PI-1	SN PLANT	115	TURNER	115	1	1						
2004PI-1	BUCKEYE	230	RUSKMTR8	230	1	1						
2004PI-1	SILVR SP	230	SILV SPN	230	1	2						
2004PI-1	SILVR SP	230	OCALA 1	230	1	2						
2004PI-1	RIO PINR	230	CURRY FD	230	1	2						
2004PI-1	STANTON	230	CURRY FD	230	1	2						
2004PI-1	OSCEOLA	230	LKAGNES	230	1	16						
2004PI-1	SHELD	230	LK TARP	230	1	2						
2004PI-1	PEBB	230	CREWSLK	230	1	13						
2004PI-1	PEBB	230	N BARTOW	230	1	2						
2004PI-1	RECKER	230	LKAGNES	230	1	16						
2004PI-1	RECKER	230	ARIANA	230	1	16						
2004PI-1	RECKER	230	CREWSLK	230	1	13						
2004PI-1	B BEND	230	MANATEE	230	1	1						
2004PI-1	RUSKIN T	230	MANATEE	230	1	1						
2004PI-1	IND RIV	230	IND RIV	115	1	11						
2004PI-1	SHELD	230	SHELD-NW	69	1	16						
2004PI-1	LARGO	230	LARGO A	69	1	2						
2004PI-1	CLMT EST	230	CLMT EST	69	1	2						
2004PI-1	11TH AVE	230	ELEVEN-E	69	1	16						
2004PI-1	WINDERME	230	WINDERME	69	1	2						
2004PI-1	PASADENA	230	PASADENA	115	1	2						
2004PI-1	ARIANA	230	ARIANA-N	69	1	16						
2004PI-1	SELOSE	230	SELOSE-N	69	1	16						
2004PI-1	GAPWAY	230	GAPWAY	69	1	16						
2004PI-1	CREWSLK	230	CREWSLK	69	1	13						
2004PI-1	TENOROC	230	TENOROC	69	1	13						
2004PI-1	BARCOLA	230	WEST	230	1	2						
2004PI-1	EATON PK	230	CREWSLK	230	1	13						
2004PI-1	EATON PK	230	EATON PK	69	1	13						
2004PI-1	EATON PK	230	TENOROC	230	1	13						
2004PI-1	RECKER	230	GAPWAY	230	1	16						
2004PI-1	SN PLANT	115	TURNER	115	1	1						
2004PI-2	SN PLANT	230	SYLVAN	230	1	1						
2004PI-2	SYLVAN	230	N LONGWD	230	1	1						
2004PI-2	IND RIV	230	STANTON	230	1	11						
2004PI-2	SN PLANT	115	TURNER	115	1	1						
2004PI-2	BUCKEYE	230	RUSKMTR8	230	1	1		100.8				
2004PI-2	SILVR SP	230	SILV SPN	230	1	2						
2004PI-2	SILVR SP	230	OCALA 1	230	1	2						
2004PI-2	RIO PINR	230	CURRY FD	230	1	2						
2004PI-2	STANTON	230	CURRY FD	230	1	2						
2004PI-2	OSCEOLA	230	LKAGNES	230	1	16						
2004PI-2	SHELD	230	LK TARP	230	1	2						
2004PI-2	PEBB	230	CREWSLK	230	1	13						
2004PI-2	PEBB	230	N BARTOW	230	1	2						
2004PI-2	RECKER	230	LKAGNES	230	1	16						
2004PI-2	RECKER	230	ARIANA	230	1	16						
2004PI-2	RECKER	230	CREWSLK	230	1	13						
2004PI-2	B BEND	230	MANATEE	230	1	1						
2004PI-2	RUSKIN T	230	MANATEE	230	1	1						
2004PI-2	IND RIV	230	IND RIV	115	1	11						
2004PI-2	SHELD	230	SHELD-NW	69	1	16						
2004PI-2	LARGO	230	LARGO A	69	1	2						
2004PI-2	CLMT EST	230	CLMT EST	69	1	2						
2004PI-2	11TH AVE	230	ELEVEN-E	69	1	16						
2004PI-2	WINDERME	230	WINDERME	69	1	2						
2004PI-2	PASADENA	230	PASADENA	115	1	2						
2004PI-2	ARIANA	230	ARIANA-N	69	1	16						
2004PI-2	SELOSE	230	SELOSE-N	69	1	16						
2004PI-2	GAPWAY	230	GAPWAY	69	1	16						
2004PI-2	CREWSLK	230	CREWSLK	69	1	13						
2004PI-2	TENOROC	230	TENOROC	69	1	13						
2004PI-2	BARCOLA	230	WEST	230	1	2						
2004PI-2	EATON PK	230	CREWSLK	230	1	13						
2004PI-2	EATON PK	230	EATON PK	69	1	13						
2004PI-2	EATON PK	230	TENOROC	230	1	13						
2004PI-2	RECKER	230	GAPWAY	230	1	16						
2004PI-2	SN PLANT	115	TURNER	115	1	1						

Table II
Comparison of Line & Transformer Flows
Following N-1 Disturbances
for Various OEC 500 MW Generation Alternatives

100% Load Base Case

All Flows above 100% of Emergency rating are Shown

Monitored Branches							Case 2004PI Base No OEC Gen	Case 2004PIA Sell to FPL	Case 2004PIB Sell to FPC	Case 2004PIC Sell to TEC	Case 2004PID Sell to JEA	Case 2004PIE Sell to SEM
Case	Bus 1	kV 1	Bus 2	kV 2	ckt	Area	Percent	Percent	Percent	Percent	Percent	Percent
2004PI-3	SN PLANT	230	SYLVAN	230	1	1						
2004PI-3	SYLVAN	230	N LONGWD	230	1	1						
2004PI-3	IND RIV	230	STANTON	230	1	11						
2004PI-3	SN PLANT	115	TURNER	115	1	1						
2004PI-3	BUCKEYE	230	RUSKMTR8	230	1	1						
2004PI-3	SILVR SP	230	SILV SPN	230	1	2						
2004PI-3	SILVR SP	230	OCALA 1	230	1	2						
2004PI-3	RIO PINR	230	CURRY FD	230	1	2						
2004PI-3	STANTON	230	CURRY FD	230	1	2						
2004PI-3	OSCEOLA	230	LKAGNES	230	1	16						
2004PI-3	SHELD	230	LK TARP	230	1	2						
2004PI-3	PEBB	230	CREWSLK	230	1	13						
2004PI-3	PEBB	230	N BARTOW	230	1	2						
2004PI-3	RECKER	230	LKAGNES	230	1	16						
2004PI-3	RECKER	230	ARIANA	230	1	16						
2004PI-3	RECKER	230	CREWSLK	230	1	13						
2004PI-3	B BEND	230	MANATEE	230	1	1						
2004PI-3	RUSKIN T	230	MANATEE	230	1	1						
2004PI-3	IND RIV	230	IND RIV	115	1	11						
2004PI-3	SHELD	230	SHELD-NW	69	1	16						
2004PI-3	LARGO	230	LARGO A	69	1	2						
2004PI-3	CLMT EST	230	CLMT EST	69	1	2						
2004PI-3	11TH AVE	230	ELEVEN-E	69	1	16						
2004PI-3	WINDERME	230	WINDERME	69	1	2						
2004PI-3	PASADENA	230	PASADENA	115	1	2						
2004PI-3	ARIANA	230	ARIANA-N	69	1	16						
2004PI-3	SELOSE	230	SELOSE-N	69	1	16						
2004PI-3	GAPWAY	230	GAPWAY	69	1	16						
2004PI-3	CREWSLK	230	CREWSLK	69	1	13						
2004PI-3	TENOROC	230	TENOROC	69	1	13						
2004PI-3	BARCOLA	230	WEST	230	1	2						
2004PI-3	EATON PK	230	CREWSLK	230	1	13						
2004PI-3	EATON PK	230	EATON PK	69	1	13						
2004PI-3	EATON PK	230	TENOROC	230	1	13						
2004PI-3	RECKER	230	GAPWAY	230	1	16						
2004PI-3	SN PLANT	115	TURNER	115	1	1						
2004PI-4	SN PLANT	230	SYLVAN	230	1	1						
2004PI-4	SYLVAN	230	N LONGWD	230	1	1						
2004PI-4	IND RIV	230	STANTON	230	1	11						
2004PI-4	SN PLANT	115	TURNER	115	1	1						
2004PI-4	BUCKEYE	230	RUSKMTR8	230	1	1						
2004PI-4	SILVR SP	230	SILV SPN	230	1	2						
2004PI-4	SILVR SP	230	OCALA 1	230	1	2						
2004PI-4	RIO PINR	230	CURRY FD	230	1	2						
2004PI-4	STANTON	230	CURRY FD	230	1	2						
2004PI-4	OSCEOLA	230	LKAGNES	230	1	16						
2004PI-4	SHELD	230	LK TARP	230	1	2						
2004PI-4	PEBB	230	CREWSLK	230	1	13						
2004PI-4	PEBB	230	N BARTOW	230	1	2						
2004PI-4	RECKER	230	LKAGNES	230	1	16						
2004PI-4	RECKER	230	ARIANA	230	1	16						
2004PI-4	RECKER	230	CREWSLK	230	1	13						
2004PI-4	B BEND	230	MANATEE	230	1	1						
2004PI-4	RUSKIN T	230	MANATEE	230	1	1						
2004PI-4	IND RIV	230	IND RIV	115	1	11						
2004PI-4	SHELD	230	SHELD-NW	69	1	16						
2004PI-4	LARGO	230	LARGO A	69	1	2						
2004PI-4	CLMT EST	230	CLMT EST	69	1	2						
2004PI-4	11TH AVE	230	ELEVEN-E	69	1	16						
2004PI-4	WINDERME	230	WINDERME	69	1	2						
2004PI-4	PASADENA	230	PASADENA	115	1	2						
2004PI-4	ARIANA	230	ARIANA-N	69	1	16						
2004PI-4	SELOSE	230	SELOSE-N	69	1	16						
2004PI-4	GAPWAY	230	GAPWAY	69	1	16						
2004PI-4	CREWSLK	230	CREWSLK	69	1	13						
2004PI-4	TENOROC	230	TENOROC	69	1	13						
2004PI-4	BARCOLA	230	WEST	230	1	2						
2004PI-4	EATON PK	230	CREWSLK	230	1	13						
2004PI-4	EATON PK	230	EATON PK	69	1	13						
2004PI-4	EATON PK	230	TENOROC	230	1	13						
2004PI-4	RECKER	230	GAPWAY	230	1	16						
2004PI-4	SN PLANT	115	TURNER	115	1	1						

Table II
Comparison of Line & Transformer Flows
Following N-1 Disturbances
for Various OEC 500 MW Generation Alternatives

100% Load Base Case

All Flows above 100% of Emergency rating are Shown

Monitored Branches							Case 2004PI Base No OEC Gen	Case 2004PIA Sell to FPL	Case 2004PIB Sell to FPC	Case 2004PIC Sell to TEC	Case 2004PID Sell to JEA	Case 2004PIE Sell to SEM
Case	Bus 1	KV 1	Bus 2	KV 2	ckt	Area	Percent	Percent	Percent	Percent	Percent	Percent
2004PI-5	SN PLANT	230	SYLVAN	230	1	1						
2004PI-5	SYLVAN	230	N LONGWD	230	1	1						
2004PI-5	IND RIV	230	STANTON	230	1	11						
2004PI-5	SN PLANT	115	TURNER	115	1	1						
2004PI-5	BUCKEYE	230	RUSKMTR8	230	1	1						
2004PI-5	SILVR SP	230	SILV SPN	230	1	2						
2004PI-5	SILVR SP	230	OCALA 1	230	1	2						
2004PI-5	RIO PINR	230	CURRY FD	230	1	2						
2004PI-5	STANTON	230	CURRY FD	230	1	2						
2004PI-5	OSCEOLA	230	LKAGNES	230	1	16						
2004PI-5	SHELD	230	LK TARPEN	230	1	2						
2004PI-5	PEBB	230	CREWSLK	230	1	13						
2004PI-5	PEBB	230	N BARTOW	230	1	2						
2004PI-5	RECKER	230	LKAGNES	230	1	16						
2004PI-5	RECKER	230	ARIANA	230	1	16						
2004PI-5	RECKER	230	CREWSLK	230	1	13						
2004PI-5	B BEND	230	MANATEE	230	1	1						
2004PI-5	RUSKIN T	230	MANATEE	230	1	1						
2004PI-5	IND RIV	230	IND RIV	115	1	11						
2004PI-5	SHELD	230	SHELD-NW	69	1	16						
2004PI-5	LARGO	230	LARGO A	69	1	2						
2004PI-5	CLMT EST	230	CLMT EST	69	1	2						
2004PI-5	11TH AVE	230	ELEVEN-E	69	1	16						
2004PI-5	WINDERME	230	WINDERME	69	1	2						
2004PI-5	PASADENA	230	PASADENA	115	1	2						
2004PI-5	ARIANA	230	ARIANA-N	69	1	16						
2004PI-5	SELOSE	230	SELOSE-N	69	1	16						
2004PI-5	GAPWAY	230	GAPWAY	69	1	16						
2004PI-5	CREWSLK	230	CREWSLK	69	1	13						
2004PI-5	TENOROC	230	TENOROC	69	1	13						
2004PI-5	BARCOLA	230	WEST	230	1	2						
2004PI-5	EATON PK	230	CREWSLK	230	1	13						
2004PI-5	EATON PK	230	EATON PK	69	1	13						
2004PI-5	EATON PK	230	TENOROC	230	1	13						
2004PI-5	RECKER	230	GAPWAY	230	1	16						
2004PI-5	SN PLANT	115	TURNER	115	1	1						
2004PI-6	SN PLANT	230	SYLVAN	230	1	1						
2004PI-6	SYLVAN	230	N LONGWD	230	1	1						
2004PI-6	IND RIV	230	STANTON	230	1	11						
2004PI-6	SN PLANT	115	TURNER	115	1	1						
2004PI-6	BUCKEYE	230	RUSKMTR8	230	1	1						
2004PI-6	SILVR SP	230	SILV SPN	230	1	2						
2004PI-6	SILVR SP	230	OCALA 1	230	1	2						
2004PI-6	RIO PINR	230	CURRY FD	230	1	2						
2004PI-6	STANTON	230	CURRY FD	230	1	2						
2004PI-6	OSCEOLA	230	LKAGNES	230	1	16						
2004PI-6	SHELD	230	LK TARPEN	230	1	2						
2004PI-6	PEBB	230	CREWSLK	230	1	13						
2004PI-6	PEBB	230	N BARTOW	230	1	2						
2004PI-6	RECKER	230	LKAGNES	230	1	16						
2004PI-6	RECKER	230	ARIANA	230	1	16						
2004PI-6	RECKER	230	CREWSLK	230	1	13						
2004PI-6	B BEND	230	MANATEE	230	1	1						
2004PI-6	RUSKIN T	230	MANATEE	230	1	1						
2004PI-6	IND RIV	230	IND RIV	115	1	11						
2004PI-6	SHELD	230	SHELD-NW	69	1	16						
2004PI-6	LARGO	230	LARGO A	69	1	2						
2004PI-6	CLMT EST	230	CLMT EST	69	1	2						
2004PI-6	11TH AVE	230	ELEVEN-E	69	1	16						
2004PI-6	WINDERME	230	WINDERME	69	1	2						
2004PI-6	PASADENA	230	PASADENA	115	1	2						
2004PI-6	ARIANA	230	ARIANA-N	69	1	16						
2004PI-6	SELOSE	230	SELOSE-N	69	1	16						
2004PI-6	GAPWAY	230	GAPWAY	69	1	16						
2004PI-6	CREWSLK	230	CREWSLK	69	1	13						
2004PI-6	TENOROC	230	TENOROC	69	1	13						
2004PI-6	BARCOLA	230	WEST	230	1	2						
2004PI-6	EATON PK	230	CREWSLK	230	1	13						
2004PI-6	EATON PK	230	EATON PK	69	1	13						
2004PI-6	EATON PK	230	TENOROC	230	1	13						
2004PI-6	RECKER	230	GAPWAY	230	1	16						
2004PI-6	SN PLANT	115	TURNER	115	1	1						

Table II
Comparison of Line & Transformer Flows
Following N-1 Disturbances
for Various OEC 500 MW Generation Alternatives

100% Load Base Case

All Flows above 100% of Emergency rating are Shown

Monitored Branches							Case 2004PI Base No OEC Gen	Case 2004PIA Sell to FPL	Case 2004PIB Sell to FPC	Case 2004PIC Sell to TEC	Case 2004PID Sell to JEA	Case 2004PIE Sell to SEM
Case	Bus 1	kV 1	Bus 2	kV 2	ckt	Area	Percent	Percent	Percent	Percent	Percent	Percent
2004PI-7	SN PLANT	230	SYLVAN	230	1	1						
2004PI-7	SYLVAN	230	N LONGWD	230	1	1						
2004PI-7	IND RIV	230	STANTON	230	1	11						
2004PI-7	SN PLANT	115	TURNER	115	1	1						
2004PI-7	BUCKEYE	230	RUSKMTR8	230	1	1						
2004PI-7	SILVR SP	230	SILV SPN	230	1	2						
2004PI-7	SILVR SP	230	OCALA 1	230	1	2						
2004PI-7	RIO PINR	230	CURRY FD	230	1	2						
2004PI-7	STANTON	230	CURRY FD	230	1	2						
2004PI-7	OSCEOLA	230	LKAGNES	230	1	16						
2004PI-7	SHELD	230	LK TARP	230	1	2						
2004PI-7	PEBB	230	CREWSLK	230	1	13						
2004PI-7	PEBB	230	N BARTOW	230	1	2						
2004PI-7	RECKER	230	LKAGNES	230	1	16						
2004PI-7	RECKER	230	ARIANA	230	1	16						
2004PI-7	RECKER	230	CREWSLK	230	1	13						
2004PI-7	B BEND	230	MANATEE	230	1	1						
2004PI-7	RUSKIN T	230	MANATEE	230	1	1						
2004PI-7	IND RIV	230	IND RIV	115	1	11						
2004PI-7	SHELD	230	SHELD-NW	69	1	16						
2004PI-7	LARGO	230	LARGO A	69	1	2						
2004PI-7	CLMT EST	230	CLMT EST	69	1	2						
2004PI-7	11TH AVE	230	ELEVEN-E	69	1	16						
2004PI-7	WINDERME	230	WINDERME	69	1	2						
2004PI-7	PASADENA	230	PASADENA	115	1	2						
2004PI-7	ARIANA	230	ARIANA-N	69	1	16						
2004PI-7	SELOSE	230	SELOSE-N	69	1	16						
2004PI-7	GAPWAY	230	GAPWAY	69	1	16						
2004PI-7	CREWSLK	230	CREWSLK	69	1	13						
2004PI-7	TENOROC	230	TENOROC	69	1	13						
2004PI-7	BARCOLA	230	WEST	230	1	2						
2004PI-7	EATON PK	230	CREWSLK	230	1	13						
2004PI-7	EATON PK	230	EATON PK	69	1	13						
2004PI-7	EATON PK	230	TENOROC	230	1	13						
2004PI-7	RECKER	230	GAPWAY	230	1	16						
2004PI-7	SN PLANT	115	TURNER	115	1	1						
2004PI-8	SN PLANT	230	SYLVAN	230	1	1						
2004PI-8	SYLVAN	230	N LONGWD	230	1	1						
2004PI-8	IND RIV	230	STANTON	230	1	11						
2004PI-8	SN PLANT	115	TURNER	115	1	1						
2004PI-8	BUCKEYE	230	RUSKMTR8	230	1	1						
2004PI-8	SILVR SP	230	SILV SPN	230	1	2						
2004PI-8	SILVR SP	230	OCALA 1	230	1	2						
2004PI-8	RIO PINR	230	CURRY FD	230	1	2						
2004PI-8	STANTON	230	CURRY FD	230	1	2						
2004PI-8	OSCEOLA	230	LKAGNES	230	1	16						
2004PI-8	SHELD	230	LK TARP	230	1	2						
2004PI-8	PEBB	230	CREWSLK	230	1	13						
2004PI-8	PEBB	230	N BARTOW	230	1	2						
2004PI-8	RECKER	230	LKAGNES	230	1	16						
2004PI-8	RECKER	230	ARIANA	230	1	16						
2004PI-8	RECKER	230	CREWSLK	230	1	13						
2004PI-8	B BEND	230	MANATEE	230	1	1						
2004PI-8	RUSKIN T	230	MANATEE	230	1	1						
2004PI-8	IND RIV	230	IND RIV	115	1	11						
2004PI-8	SHELD	230	SHELD-NW	69	1	16						
2004PI-8	LARGO	230	LARGO A	69	1	2						
2004PI-8	CLMT EST	230	CLMT EST	69	1	2						
2004PI-8	11TH AVE	230	ELEVEN-E	69	1	16						
2004PI-8	WINDERME	230	WINDERME	69	1	2						
2004PI-8	PASADENA	230	PASADENA	115	1	2						
2004PI-8	ARIANA	230	ARIANA-N	69	1	16						
2004PI-8	SELOSE	230	SELOSE-N	69	1	16						
2004PI-8	GAPWAY	230	GAPWAY	69	1	16						
2004PI-8	CREWSLK	230	CREWSLK	69	1	13						
2004PI-8	TENOROC	230	TENOROC	69	1	13						
2004PI-8	BARCOLA	230	WEST	230	1	2						
2004PI-8	EATON PK	230	CREWSLK	230	1	13						
2004PI-8	EATON PK	230	EATON PK	69	1	13						
2004PI-8	EATON PK	230	TENOROC	230	1	13						
2004PI-8	RECKER	230	GAPWAY	230	1	16						
2004PI-8	SN PLANT	115	TURNER	115	1	1						

Table II
Comparison of Line & Transformer Flows
Following N-1 Disturbances
for Various OEC 500 MW Generation Alternatives

100% Load Base Case

All Flows above 100% of Emergency rating are Shown

Monitored Branches							Case 2004PI	Case 2004PIA	Case 2004PIB	Case 2004PIC	Case 2004PID	Case 2004PIE
Case	Bus 1	kV 1	Bus 2	kV 2	ckt	Area	Base No OEC Gen Percent	Sell to FPL Percent	Sell to FPC Percent	Sell to TEC Percent	Sell to JEA Percent	Sell to SEM Percent
2004PI-9	SN PLANT	230	SYLVAN	230	1	1						
2004PI-9	SYLVAN	230	N LONGWD	230	1	1						
2004PI-9	IND RIV	230	STANTON	230	1	11						
2004PI-9	SN PLANT	115	TURNER	115	1	1						
2004PI-9	BUCKEYE	230	RUSKMTR8	230	1	1						
2004PI-9	SILVR SP	230	SILV SPN	230	1	2						
2004PI-9	SILVR SP	230	OCALA 1	230	1	2						
2004PI-9	RIO PINR	230	CURRY FD	230	1	2						
2004PI-9	STANTON	230	CURRY FD	230	1	2						
2004PI-9	OSCEOLA	230	LKAGNES	230	1	16						
2004PI-9	SHELD	230	LK TARPEN	230	1	2						
2004PI-9	PEBB	230	CREWSLK	230	1	13						
2004PI-9	PEBB	230	N BARTOW	230	1	2						
2004PI-9	RECKER	230	LKAGNES	230	1	16						
2004PI-9	RECKER	230	ARIANA	230	1	16						
2004PI-9	RECKER	230	CREWSLK	230	1	13						
2004PI-9	B BEND	230	MANATEE	230	1	1						
2004PI-9	RUSKIN T	230	MANATEE	230	1	1						
2004PI-9	IND RIV	230	IND RIV	115	1	11						
2004PI-9	SHELD	230	SHELD-NW	69	1	16						
2004PI-9	LARGO	230	LARGO A	69	1	2						
2004PI-9	CLMT EST	230	CLMT EST	69	1	2						
2004PI-9	11TH AVE	230	ELEVEN-E	69	1	16						
2004PI-9	WINDERME	230	WINDERME	69	1	2						
2004PI-9	PASADENA	230	PASADENA	115	1	2						
2004PI-9	ARIANA	230	ARIANA-N	69	1	16						
2004PI-9	SELOSE	230	SELOSE-N	69	1	16						
2004PI-9	GAPWAY	230	GAPWAY	69	1	16						
2004PI-9	CREWSLK	230	CREWSLK	69	1	13						
2004PI-9	TENOROC	230	TENOROC	69	1	13						
2004PI-9	BARCOLA	230	WEST	230	1	2						
2004PI-9	EATON PK	230	CREWSLK	230	1	13						
2004PI-9	EATON PK	230	EATON PK	69	1	13						
2004PI-9	EATON PK	230	TENOROC	230	1	13						
2004PI-9	RECKER	230	GAPWAY	230	1	16						
2004PI-9	SN PLANT	115	TURNER	115	1	1						
2004PI-10	SN PLANT	230	SYLVAN	230	1	1						
2004PI-10	SYLVAN	230	N LONGWD	230	1	1						
2004PI-10	IND RIV	230	STANTON	230	1	11						
2004PI-10	SN PLANT	115	TURNER	115	1	1						
2004PI-10	BUCKEYE	230	RUSKMTR8	230	1	1						
2004PI-10	SILVR SP	230	SILV SPN	230	1	2						
2004PI-10	SILVR SP	230	OCALA 1	230	1	2						
2004PI-10	RIO PINR	230	CURRY FD	230	1	2						
2004PI-10	STANTON	230	CURRY FD	230	1	2						
2004PI-10	OSCEOLA	230	LKAGNES	230	1	16						
2004PI-10	SHELD	230	LK TARPEN	230	1	2						
2004PI-10	PEBB	230	CREWSLK	230	1	13						
2004PI-10	PEBB	230	N BARTOW	230	1	2						
2004PI-10	RECKER	230	LKAGNES	230	1	16						
2004PI-10	RECKER	230	ARIANA	230	1	16						
2004PI-10	RECKER	230	CREWSLK	230	1	13						
2004PI-10	B BEND	230	MANATEE	230	1	1						
2004PI-10	RUSKIN T	230	MANATEE	230	1	1						
2004PI-10	IND RIV	230	IND RIV	115	1	11						
2004PI-10	SHELD	230	SHELD-NW	69	1	16						
2004PI-10	LARGO	230	LARGO A	69	1	2						
2004PI-10	CLMT EST	230	CLMT EST	69	1	2						
2004PI-10	11TH AVE	230	ELEVEN-E	69	1	16						
2004PI-10	WINDERME	230	WINDERME	69	1	2						
2004PI-10	PASADENA	230	PASADENA	115	1	2						
2004PI-10	ARIANA	230	ARIANA-N	69	1	16						
2004PI-10	SELOSE	230	SELOSE-N	69	1	16						
2004PI-10	GAPWAY	230	GAPWAY	69	1	16						
2004PI-10	CREWSLK	230	CREWSLK	69	1	13						
2004PI-10	TENOROC	230	TENOROC	69	1	13						
2004PI-10	BARCOLA	230	WEST	230	1	2						
2004PI-10	EATON PK	230	CREWSLK	230	1	13						
2004PI-10	EATON PK	230	EATON PK	69	1	13						
2004PI-10	EATON PK	230	TENOROC	230	1	13						
2004PI-10	RECKER	230	GAPWAY	230	1	16						
2004PI-10	SN PLANT	115	TURNER	115	1	1						

Table II

**Comparison of Line & Transformer Flows
Following N-1 Disturbances
for Various OEC 500 MW Generation Alternatives**

100% Load Base Case

All Flows above 100% of Emergency rating are Shown

Monitored Branches							Case 2004PI Base No OEC Gen	Case 2004PIA Sell to FPL	Case 2004PIB Sell to FPC	Case 2004PIC Sell to TEC	Case 2004PID Sell to JEA	Case 2004PIE Sell to SEM
Case	Bus 1	kV 1	Bus 2	kV 2	ckt	Area	Percent	Percent	Percent	Percent	Percent	Percent
2004PI-11	SN PLANT	230	SYLVAN	230	1	1						
2004PI-11	SYLVAN	230	N LONGWD	230	1	1						
2004PI-11	IND RIV	230	STANTON	230	1	11						
2004PI-11	SN PLANT	115	TURNER	115	1	1						
2004PI-11	BUCKEYE	230	RUSKMTR8	230	1	1						
2004PI-11	SILVR SP	230	SILV SPN	230	1	2						
2004PI-11	SILVR SP	230	OCALA 1	230	1	2						
2004PI-11	RIO PINR	230	CURRY FD	230	1	2						
2004PI-11	STANTON	230	CURRY FD	230	1	2						
2004PI-11	OSCEOLA	230	LKAGNES	230	1	16						
2004PI-11	SHELD	230	LK TARP	230	1	2						
2004PI-11	PEBB	230	CREWSLK	230	1	13						
2004PI-11	PEBB	230	N BARTOW	230	1	2						
2004PI-11	RECKER	230	LKAGNES	230	1	16						
2004PI-11	RECKER	230	ARIANA	230	1	16						
2004PI-11	RECKER	230	CREWSLK	230	1	13						
2004PI-11	B BEND	230	MANATEE	230	1	1						
2004PI-11	RUSKIN T	230	MANATEE	230	1	1						
2004PI-11	IND RIV	230	IND RIV	115	1	11						
2004PI-11	SHELD	230	SHELD-NW	69	1	16						
2004PI-11	LARGO	230	LARGO A	69	1	2						
2004PI-11	CLMT EST	230	CLMT EST	69	1	2						
2004PI-11	11TH AVE	230	ELEVEN-E	69	1	16						
2004PI-11	WINDERME	230	WINDERME	69	1	2						
2004PI-11	PASADENA	230	PASADENA	115	1	2						
2004PI-11	ARIANA	230	ARIANA-N	69	1	16						
2004PI-11	SELOSE	230	SELOSE-N	69	1	16						
2004PI-11	GAPWAY	230	GAPWAY	69	1	16						
2004PI-11	CREWSLK	230	CREWSLK	69	1	13						
2004PI-11	TENOROC	230	TENOROC	69	1	13						
2004PI-11	BARCOLA	230	WEST	230	1	2						
2004PI-11	EATON PK	230	CREWSLK	230	1	13						
2004PI-11	EATON PK	230	EATON PK	69	1	13						
2004PI-11	EATON PK	230	TENOROC	230	1	13						
2004PI-11	RECKER	230	GAPWAY	230	1	16						
2004PI-11	SN PLANT	115	TURNER	115	1	1						
2004PI-12	SN PLANT	230	SYLVAN	230	1	1						
2004PI-12	SYLVAN	230	N LONGWD	230	1	1						
2004PI-12	IND RIV	230	STANTON	230	1	11						
2004PI-12	SN PLANT	115	TURNER	115	1	1						
2004PI-12	BUCKEYE	230	RUSKMTR8	230	1	1						
2004PI-12	SILVR SP	230	SILV SPN	230	1	2						
2004PI-12	SILVR SP	230	OCALA 1	230	1	2						
2004PI-12	RIO PINR	230	CURRY FD	230	1	2						
2004PI-12	STANTON	230	CURRY FD	230	1	2						
2004PI-12	OSCEOLA	230	LKAGNES	230	1	16						
2004PI-12	SHELD	230	LK TARP	230	1	2						
2004PI-12	PEBB	230	CREWSLK	230	1	13						
2004PI-12	PEBB	230	N BARTOW	230	1	2						
2004PI-12	RECKER	230	LKAGNES	230	1	16						
2004PI-12	RECKER	230	ARIANA	230	1	16						
2004PI-12	RECKER	230	CREWSLK	230	1	13						
2004PI-12	B BEND	230	MANATEE	230	1	1						
2004PI-12	RUSKIN T	230	MANATEE	230	1	1						
2004PI-12	IND RIV	230	IND RIV	115	1	11						
2004PI-12	SHELD	230	SHELD-NW	69	1	16						
2004PI-12	LARGO	230	LARGO A	69	1	2						
2004PI-12	CLMT EST	230	CLMT EST	69	1	2						
2004PI-12	11TH AVE	230	ELEVEN-E	69	1	16						
2004PI-12	WINDERME	230	WINDERME	69	1	2						
2004PI-12	PASADENA	230	PASADENA	115	1	2						
2004PI-12	ARIANA	230	ARIANA-N	69	1	16						
2004PI-12	SELOSE	230	SELOSE-N	69	1	16						
2004PI-12	GAPWAY	230	GAPWAY	69	1	16						
2004PI-12	CREWSLK	230	CREWSLK	69	1	13						
2004PI-12	TENOROC	230	TENOROC	69	1	13						
2004PI-12	BARCOLA	230	WEST	230	1	2						
2004PI-12	EATON PK	230	CREWSLK	230	1	13						
2004PI-12	EATON PK	230	EATON PK	69	1	13						
2004PI-12	EATON PK	230	TENOROC	230	1	13						
2004PI-12	RECKER	230	GAPWAY	230	1	16						
2004PI-12	SN PLANT	115	TURNER	115	1	1						

Table II
Comparison of Line & Transformer Flows
Following N-1 Disturbances
for Various OEC 500 MW Generation Alternatives

100% Load Base Case

All Flows above 100% of Emergency rating are Shown

Monitored Branches							Case 2004PI Base No OEC Gen	Case 2004PIA Sell to FPL	Case 2004PIB Sell to FPC	Case 2004PIC Sell to TEC	Case 2004PID Sell to JEA	Case 2004PIE Sell to SEM
Case	Bus 1	kV 1	Bus 2	kV 2	ckt	Area	Percent	Percent	Percent	Percent	Percent	Percent
2004PI-13	SN PLANT	230	SYLVAN	230	1	1						
2004PI-13	SYLVAN	230	N LONGWD	230	1	1						
2004PI-13	IND RIV	230	STANTON	230	1	11						
2004PI-13	SN PLANT	115	TURNER	115	1	1						
2004PI-13	BUCKEYE	230	RUSKMTR8	230	1	1						
2004PI-13	SILVR SP	230	SILV SPN	230	1	2						
2004PI-13	SILVR SP	230	OCALA 1	230	1	2						
2004PI-13	RIO PINR	230	CURRY FD	230	1	2						
2004PI-13	STANTON	230	CURRY FD	230	1	2						
2004PI-13	OSCEOLA	230	LKAGNES	230	1	16						
2004PI-13	SHELD	230	LK TARP	230	1	2						
2004PI-13	PEBB	230	CREWSLK	230	1	13						
2004PI-13	PEBB	230	N BARTOW	230	1	2						
2004PI-13	RECKER	230	LKAGNES	230	1	16						
2004PI-13	RECKER	230	ARIANA	230	1	16						
2004PI-13	RECKER	230	CREWSLK	230	1	13						
2004PI-13	B BEND	230	MANATEE	230	1	1						
2004PI-13	RUSKIN T	230	MANATEE	230	1	1						
2004PI-13	IND RIV	230	IND RIV	115	1	11						
2004PI-13	SHELD	230	SHELD-NW	69	1	16						
2004PI-13	LARGO	230	LARGO A	69	1	2						
2004PI-13	CLMT EST	230	CLMT EST	69	1	2						
2004PI-13	11TH AVE	230	ELEVEN-E	69	1	16						
2004PI-13	WINDERME	230	WINDERME	69	1	2						
2004PI-13	PASADENA	230	PASADENA	115	1	2						
2004PI-13	ARIANA	230	ARIANA-N	69	1	16						
2004PI-13	SELOSE	230	SELOSE-N	69	1	16						
2004PI-13	GAPWAY	230	GAPWAY	69	1	16						
2004PI-13	CREWSLK	230	CREWSLK	69	1	13						
2004PI-13	TENOROC	230	TENOROC	69	1	13						
2004PI-13	BARCOLA	230	WEST	230	1	2						
2004PI-13	EATON PK	230	CREWSLK	230	1	13						
2004PI-13	EATON PK	230	EATON PK	69	1	13						
2004PI-13	EATON PK	230	TENOROC	230	1	13						
2004PI-13	RECKER	230	GAPWAY	230	1	16						
2004PI-13	SN PLANT	115	TURNER	115	1	1						
2004PI-15	SN PLANT	230	SYLVAN	230	1	1						
2004PI-15	SYLVAN	230	N LONGWD	230	1	1						
2004PI-15	IND RIV	230	STANTON	230	1	11						
2004PI-15	SN PLANT	115	TURNER	115	1	1						
2004PI-15	BUCKEYE	230	RUSKMTR8	230	1	1						
2004PI-15	SILVR SP	230	SILV SPN	230	1	2						
2004PI-15	SILVR SP	230	OCALA 1	230	1	2						
2004PI-15	RIO PINR	230	CURRY FD	230	1	2						
2004PI-15	STANTON	230	CURRY FD	230	1	2						
2004PI-15	OSCEOLA	230	LKAGNES	230	1	16						
2004PI-15	SHELD	230	LK TARP	230	1	2						
2004PI-15	PEBB	230	CREWSLK	230	1	13						
2004PI-15	PEBB	230	N BARTOW	230	1	2						
2004PI-15	RECKER	230	LKAGNES	230	1	16						
2004PI-15	RECKER	230	ARIANA	230	1	16						
2004PI-15	RECKER	230	CREWSLK	230	1	13						
2004PI-15	B BEND	230	MANATEE	230	1	1						
2004PI-15	RUSKIN T	230	MANATEE	230	1	1						
2004PI-15	IND RIV	230	IND RIV	115	1	11						
2004PI-15	SHELD	230	SHELD-NW	69	1	16						
2004PI-15	LARGO	230	LARGO A	69	1	2						
2004PI-15	CLMT EST	230	CLMT EST	69	1	2						
2004PI-15	11TH AVE	230	ELEVEN-E	69	1	16						
2004PI-15	WINDERME	230	WINDERME	69	1	2						
2004PI-15	PASADENA	230	PASADENA	115	1	2						
2004PI-15	ARIANA	230	ARIANA-N	69	1	16						
2004PI-15	SELOSE	230	SELOSE-N	69	1	16						
2004PI-15	GAPWAY	230	GAPWAY	69	1	16						
2004PI-15	CREWSLK	230	CREWSLK	69	1	13						
2004PI-15	TENOROC	230	TENOROC	69	1	13						
2004PI-15	BARCOLA	230	WEST	230	1	2						
2004PI-15	EATON PK	230	CREWSLK	230	1	13						
2004PI-15	EATON PK	230	EATON PK	69	1	13						
2004PI-15	EATON PK	230	TENOROC	230	1	13						
2004PI-15	RECKER	230	GAPWAY	230	1	16						
2004PI-15	SN PLANT	115	TURNER	115	1	1						

Table II
Comparison of Line & Transformer Flows
Following N-1 Disturbances
for Various OEC 500 MW Generation Alternatives

100% Load Base Case

All Flows above 100% of Emergency rating are Shown

Monitored Branches							Case 2004PI Base No OEC Gen	Case 2004PIA Sell to FPL	Case 2004PIB Sell to FPC	Case 2004PIC Sell to TEC	Case 2004PID Sell to JEA	Case 2004PIE Sell to SEM
Case	Bus 1	kV 1	Bus 2	kV 2	ckt	Area	Percent	Percent	Percent	Percent	Percent	Percent
2004PI-16	SN PLANT	230	SYLVAN	230	1	1						
2004PI-16	SYLVAN	230	N LONGWD	230	1	1						
2004PI-16	IND RIV	230	STANTON	230	1	11						
2004PI-16	SN PLANT	115	TURNER	115	1	1						
2004PI-16	BUCKEYE	230	RUSKMTR8	230	1	1						
2004PI-16	SILVR SP	230	SILV SPN	230	1	2						
2004PI-16	SILVR SP	230	OCALA 1	230	1	2						
2004PI-16	RIO PINR	230	CURRY FD	230	1	2						
2004PI-16	STANTON	230	CURRY FD	230	1	2						
2004PI-16	OSCEOLA	230	LKAGNES	230	1	16						
2004PI-16	SHELD	230	LK TARNP	230	1	2						
2004PI-16	PEBB	230	CREWSLK	230	1	13						
2004PI-16	PEBB	230	N BARTOW	230	1	2						
2004PI-16	RECKER	230	LKAGNES	230	1	16						
2004PI-16	RECKER	230	ARIANA	230	1	16						
2004PI-16	RECKER	230	CREWSLK	230	1	13						
2004PI-16	B BEND	230	MANATEE	230	1	1						
2004PI-16	RUSKIN T	230	MANATEE	230	1	1						
2004PI-16	IND RIV	230	IND RIV	115	1	11						
2004PI-16	SHELD	230	SHELD-NW	69	1	16						
2004PI-16	LARGO	230	LARGO A	69	1	2						
2004PI-16	CLMT EST	230	CLMT EST	69	1	2						
2004PI-16	11TH AVE	230	ELEVEN-E	69	1	16						
2004PI-16	WINDERME	230	WINDERME	69	1	2						
2004PI-16	PASADENA	230	PASADENA	115	1	2						
2004PI-16	ARIANA	230	ARIANA-N	69	1	16						
2004PI-16	SELOSE	230	SELOSE-N	69	1	16						
2004PI-16	GAPWAY	230	GAPWAY	69	1	16						
2004PI-16	CREWSLK	230	CREWSLK	69	1	13						
2004PI-16	TENOROC	230	TENOROC	69	1	13						
2004PI-16	BARCOLA	230	WEST	230	1	2						
2004PI-16	EATON PK	230	CREWSLK	230	1	13						
2004PI-16	EATON PK	230	EATON PK	69	1	13						
2004PI-16	EATON PK	230	TENOROC	230	1	13						
2004PI-16	RECKER	230	GAPWAY	230	1	16						
2004PI-16	SN PLANT	115	TURNER	115	1	1						
2004PI-17	SN PLANT	230	SYLVAN	230	1	1						
2004PI-17	SYLVAN	230	N LONGWD	230	1	1						
2004PI-17	IND RIV	230	STANTON	230	1	11						
2004PI-17	SN PLANT	115	TURNER	115	1	1						
2004PI-17	BUCKEYE	230	RUSKMTR8	230	1	1						
2004PI-17	SILVR SP	230	SILV SPN	230	1	2						
2004PI-17	SILVR SP	230	OCALA 1	230	1	2						
2004PI-17	RIO PINR	230	CURRY FD	230	1	2						
2004PI-17	STANTON	230	CURRY FD	230	1	2						
2004PI-17	OSCEOLA	230	LKAGNES	230	1	16						
2004PI-17	SHELD	230	LK TARNP	230	1	2						
2004PI-17	PEBB	230	CREWSLK	230	1	13						
2004PI-17	PEBB	230	N BARTOW	230	1	2						
2004PI-17	RECKER	230	LKAGNES	230	1	16						
2004PI-17	RECKER	230	ARIANA	230	1	16						
2004PI-17	RECKER	230	CREWSLK	230	1	13						
2004PI-17	B BEND	230	MANATEE	230	1	1						
2004PI-17	RUSKIN T	230	MANATEE	230	1	1						
2004PI-17	IND RIV	230	IND RIV	115	1	11						
2004PI-17	SHELD	230	SHELD-NW	69	1	16						
2004PI-17	LARGO	230	LARGO A	69	1	2						
2004PI-17	CLMT EST	230	CLMT EST	69	1	2						
2004PI-17	11TH AVE	230	ELEVEN-E	69	1	16						
2004PI-17	WINDERME	230	WINDERME	69	1	2						
2004PI-17	PASADENA	230	PASADENA	115	1	2						
2004PI-17	ARIANA	230	ARIANA-N	69	1	16						
2004PI-17	SELOSE	230	SELOSE-N	69	1	16						
2004PI-17	GAPWAY	230	GAPWAY	69	1	16						
2004PI-17	CREWSLK	230	CREWSLK	69	1	13						
2004PI-17	TENOROC	230	TENOROC	69	1	13						
2004PI-17	BARCOLA	230	WEST	230	1	2						
2004PI-17	EATON PK	230	CREWSLK	230	1	13						
2004PI-17	EATON PK	230	EATON PK	69	1	13						
2004PI-17	EATON PK	230	TENOROC	230	1	13						
2004PI-17	RECKER	230	GAPWAY	230	1	16						
2004PI-17	SN PLANT	115	TURNER	115	1	1						

Table II
Comparison of Line & Transformer Flows
Following N-1 Disturbances
for Various OEC 500 MW Generation Alternatives

100% Load Base Case

All Flows above 100% of Emergency rating are Shown

Monitored Branches							Case 2004PI	Case 2004PIA	Case 2004PIB	Case 2004PIC	Case 2004PID	Case 2004PIE
Case	Bus 1	kV 1	Bus 2	kV 2	ckt	Area	Base No OEC Gen Percent	Sell to FPL Percent	Sell to FPC Percent	Sell to TEC Percent	Sell to JEA Percent	Sell to SEM Percent
2004PI-18	SN PLANT	230	SYLVAN	230	1	1						
2004PI-18	SYLVAN	230	N LONGWD	230	1	1						
2004PI-18	IND RIV	230	STANTON	230	1	11						
2004PI-18	SN PLANT	115	TURNER	115	1	1						
2004PI-18	BUCKEYE	230	RUSKMTR8	230	1	1						
2004PI-18	SILVR SP	230	SILV SPN	230	1	2						
2004PI-18	SILVR SP	230	OCALA 1	230	1	2						
2004PI-18	RIO PINR	230	CURRY FD	230	1	2						
2004PI-18	STANTON	230	CURRY FD	230	1	2						
2004PI-18	OSCEOLA	230	LKAGNES	230	1	16						
2004PI-18	SHELD	230	LK TARP	230	1	2						
2004PI-18	PEBB	230	CREWSLK	230	1	13						
2004PI-18	PEBB	230	N BARTOW	230	1	2						
2004PI-18	RECKER	230	LKAGNES	230	1	16						
2004PI-18	RECKER	230	ARIANA	230	1	16						
2004PI-18	RECKER	230	CREWSLK	230	1	13						
2004PI-18	B BEND	230	MANATEE	230	1	1						
2004PI-18	RUSKIN T	230	MANATEE	230	1	1						
2004PI-18	IND RIV	230	IND RIV	115	1	11						
2004PI-18	SHELD	230	SHELD-NW	69	1	16						
2004PI-18	LARGO	230	LARGO A	69	1	2						
2004PI-18	CLMT EST	230	CLMT EST	69	1	2						
2004PI-18	11TH AVE	230	ELEVEN-E	69	1	16						
2004PI-18	WINDERME	230	WINDERME	69	1	2						
2004PI-18	PASADENA	230	PASADENA	115	1	2						
2004PI-18	ARIANA	230	ARIANA-N	69	1	16						
2004PI-18	SELOSE	230	SELOSE-N	69	1	16						
2004PI-18	GAPWAY	230	GAPWAY	69	1	16						
2004PI-18	CREWSLK	230	CREWSLK	69	1	13						
2004PI-18	TENOROC	230	TENOROC	69	1	13						
2004PI-18	BARCOLA	230	WEST	230	1	2						
2004PI-18	EATON PK	230	CREWSLK	230	1	13						
2004PI-18	EATON PK	230	EATON PK	69	1	13						
2004PI-18	EATON PK	230	TENOROC	230	1	13						
2004PI-18	RECKER	230	GAPWAY	230	1	16						
2004PI-18	SN PLANT	115	TURNER	115	1	1						
2004PI-19	SN PLANT	230	SYLVAN	230	1	1						
2004PI-19	SYLVAN	230	N LONGWD	230	1	1						
2004PI-19	IND RIV	230	STANTON	230	1	11						
2004PI-19	SN PLANT	115	TURNER	115	1	1						
2004PI-19	BUCKEYE	230	RUSKMTR8	230	1	1						
2004PI-19	SILVR SP	230	SILV SPN	230	1	2						
2004PI-19	SILVR SP	230	OCALA 1	230	1	2						
2004PI-19	RIO PINR	230	CURRY FD	230	1	2						
2004PI-19	STANTON	230	CURRY FD	230	1	2						
2004PI-19	OSCEOLA	230	LKAGNES	230	1	16						
2004PI-19	SHELD	230	LK TARP	230	1	2						
2004PI-19	PEBB	230	CREWSLK	230	1	13						
2004PI-19	PEBB	230	N BARTOW	230	1	2						
2004PI-19	RECKER	230	LKAGNES	230	1	16						
2004PI-19	RECKER	230	ARIANA	230	1	16						
2004PI-19	RECKER	230	CREWSLK	230	1	13						
2004PI-19	B BEND	230	MANATEE	230	1	1						
2004PI-19	RUSKIN T	230	MANATEE	230	1	1						
2004PI-19	IND RIV	230	IND RIV	115	1	11						
2004PI-19	SHELD	230	SHELD-NW	69	1	16						
2004PI-19	LARGO	230	LARGO A	69	1	2						
2004PI-19	CLMT EST	230	CLMT EST	69	1	2						
2004PI-19	11TH AVE	230	ELEVEN-E	69	1	16						
2004PI-19	WINDERME	230	WINDERME	69	1	2						
2004PI-19	PASADENA	230	PASADENA	115	1	2						
2004PI-19	ARIANA	230	ARIANA-N	69	1	16						
2004PI-19	SELOSE	230	SELOSE-N	69	1	16						
2004PI-19	GAPWAY	230	GAPWAY	69	1	16						
2004PI-19	CREWSLK	230	CREWSLK	69	1	13						
2004PI-19	TENOROC	230	TENOROC	69	1	13						
2004PI-19	BARCOLA	230	WEST	230	1	2						
2004PI-19	EATON PK	230	CREWSLK	230	1	13						
2004PI-19	EATON PK	230	EATON PK	69	1	13						
2004PI-19	EATON PK	230	TENOROC	230	1	13						
2004PI-19	RECKER	230	GAPWAY	230	1	16						
2004PI-19	SN PLANT	115	TURNER	115	1	1						

Table II
Comparison of Line & Transformer Flows
Following N-1 Disturbances
for Various OEC 500 MW Generation Alternatives

100% Load Base Case

All Flows above 100% of Emergency rating are Shown

Monitored Branches							Case 2004PI	Case 2004PIA	Case 2004PIB	Case 2004PIC	Case 2004PID	Case 2004PIE
Case	Bus 1	kV 1	Bus 2	kV 2	ckt	Area	Base No OEC Gen Percent	Sell to FPL Percent	Sell to FPC Percent	Sell to TEC Percent	Sell to JEA Percent	Sell to SEM Percent
2004PI-20	SN PLANT	230	SYLVAN	230	1	1						
2004PI-20	SYLVAN	230	N LONGWD	230	1	1						
2004PI-20	IND RIV	230	STANTON	230	1	11						
2004PI-20	SN PLANT	115	TURNER	115	1	1						
2004PI-20	BUCKEYE	230	RUSKMTRB	230	1	1						
2004PI-20	SILVR SP	230	SILV SPN	230	1	2						
2004PI-20	SILVR SP	230	OCALA 1	230	1	2						
2004PI-20	RIO PINR	230	CURRY FD	230	1	2						
2004PI-20	STANTON	230	CURRY FD	230	1	2						
2004PI-20	OSCEOLA	230	LKAGNES	230	1	16						
2004PI-20	SHELD	230	LK TARP	230	1	2						
2004PI-20	PEBB	230	CREWSLK	230	1	13						
2004PI-20	PEBB	230	N BARTOW	230	1	2						
2004PI-20	RECKER	230	LKAGNES	230	1	16						
2004PI-20	RECKER	230	ARIANA	230	1	16						
2004PI-20	RECKER	230	CREWSLK	230	1	13						
2004PI-20	B BEND	230	MANATEE	230	1	1						
2004PI-20	RUSKIN T	230	MANATEE	230	1	1						
2004PI-20	IND RIV	230	IND RIV	115	1	11						
2004PI-20	SHELD	230	SHELD-NW	69	1	16						
2004PI-20	LARGO	230	LARGO A	69	1	2						
2004PI-20	CLMT EST	230	CLMT EST	69	1	2						
2004PI-20	11TH AVE	230	ELEVEN-E	69	1	16						
2004PI-20	WINDERME	230	WINDERME	69	1	2						
2004PI-20	PASADENA	230	PASADENA	115	1	2						
2004PI-20	ARIANA	230	ARIANA-N	69	1	16						
2004PI-20	SELOSE	230	SELOSE-N	69	1	16						
2004PI-20	GAPWAY	230	GAPWAY	69	1	16						
2004PI-20	CREWSLK	230	CREWSLK	69	1	13						
2004PI-20	TENOROC	230	TENOROC	69	1	13						
2004PI-20	BARCOLA	230	WEST	230	1	2						
2004PI-20	EATON PK	230	CREWSLK	230	1	13						
2004PI-20	EATON PK	230	EATON PK	69	1	13						
2004PI-20	EATON PK	230	TENOROC	230	1	13						
2004PI-20	RECKER	230	GAPWAY	230	1	16						
2004PI-20	SN PLANT	115	TURNER	115	1	1						
2004PI-21	SN PLANT	230	SYLVAN	230	1	1						
2004PI-21	SYLVAN	230	N LONGWD	230	1	1						
2004PI-21	IND RIV	230	STANTON	230	1	11						
2004PI-21	SN PLANT	115	TURNER	115	1	1						
2004PI-21	BUCKEYE	230	RUSKMTRB	230	1	1						
2004PI-21	SILVR SP	230	SILV SPN	230	1	2						
2004PI-21	SILVR SP	230	OCALA 1	230	1	2						
2004PI-21	RIO PINR	230	CURRY FD	230	1	2						
2004PI-21	STANTON	230	CURRY FD	230	1	2						
2004PI-21	OSCEOLA	230	LKAGNES	230	1	16						
2004PI-21	SHELD	230	LK TARP	230	1	2						
2004PI-21	PEBB	230	CREWSLK	230	1	13						
2004PI-21	PEBB	230	N BARTOW	230	1	2						
2004PI-21	RECKER	230	LKAGNES	230	1	16						
2004PI-21	RECKER	230	ARIANA	230	1	16						
2004PI-21	RECKER	230	CREWSLK	230	1	13						
2004PI-21	B BEND	230	MANATEE	230	1	1						
2004PI-21	RUSKIN T	230	MANATEE	230	1	1						
2004PI-21	IND RIV	230	IND RIV	115	1	11						
2004PI-21	SHELD	230	SHELD-NW	69	1	16						
2004PI-21	LARGO	230	LARGO A	69	1	2						
2004PI-21	CLMT EST	230	CLMT EST	69	1	2						
2004PI-21	11TH AVE	230	ELEVEN-E	69	1	16						
2004PI-21	WINDERME	230	WINDERME	69	1	2						
2004PI-21	PASADENA	230	PASADENA	115	1	2						
2004PI-21	ARIANA	230	ARIANA-N	69	1	16						
2004PI-21	SELOSE	230	SELOSE-N	69	1	16						
2004PI-21	GAPWAY	230	GAPWAY	69	1	16						
2004PI-21	CREWSLK	230	CREWSLK	69	1	13						
2004PI-21	TENOROC	230	TENOROC	69	1	13						
2004PI-21	BARCOLA	230	WEST	230	1	2						
2004PI-21	EATON PK	230	CREWSLK	230	1	13						
2004PI-21	EATON PK	230	EATON PK	69	1	13						
2004PI-21	EATON PK	230	TENOROC	230	1	13						
2004PI-21	RECKER	230	GAPWAY	230	1	16						
2004PI-21	SN PLANT	115	TURNER	115	1	1						

Table II
Comparison of Line & Transformer Flows
Following N-1 Disturbances
for Various OEC 500 MW Generation Alternatives

100% Load Base Case

All Flows above 100% of Emergency rating are Shown

Monitored Branches							Case 2004PI Base No OEC Gen	Case 2004PIA Sell to FPL	Case 2004PIB Sell to FPC	Case 2004PIC Sell to TEC	Case 2004PID Sell to JEA	Case 2004PIE Sell to SEM
Case	Bus 1	kV 1	Bus 2	kV 2	ckt	Area	Percent	Percent	Percent	Percent	Percent	Percent
2004PI-22	SN PLANT	230	SYLVAN	230	1	1						
2004PI-22	SYLVAN	230	N LONGWD	230	1	1						
2004PI-22	IND RIV	230	STANTON	230	1	11						
2004PI-22	SN PLANT	115	TURNER	115	1	1						
2004PI-22	BUCKEYE	230	RUSKMTR8	230	1	1						
2004PI-22	SILVR SP	230	SILV SPN	230	1	2						
2004PI-22	SILVR SP	230	OCALA 1	230	1	2						
2004PI-22	RIO PINR	230	CURRY FD	230	1	2						
2004PI-22	STANTON	230	CURRY FD	230	1	2						
2004PI-22	OSCEOLA	230	LKAGNES	230	1	16						
2004PI-22	SHELD	230	LK TARP	230	1	2						
2004PI-22	PEBB	230	CREWSLK	230	1	13						
2004PI-22	PEBB	230	N BARTOW	230	1	2						
2004PI-22	RECKER	230	LKAGNES	230	1	16						
2004PI-22	RECKER	230	ARIANA	230	1	16						
2004PI-22	RECKER	230	CREWSLK	230	1	13						
2004PI-22	B BEND	230	MANATEE	230	1	1						
2004PI-22	RUSKIN T	230	MANATEE	230	1	1						
2004PI-22	IND RIV	230	IND RIV	115	1	11						
2004PI-22	SHELD	230	SHELD-NW	69	1	16						
2004PI-22	LARGO	230	LARGO A	69	1	2						
2004PI-22	CLMT EST	230	CLMT EST	69	1	2						
2004PI-22	11TH AVE	230	ELEVEN-E	69	1	16						
2004PI-22	WINDERME	230	WINDERME	68	1	2						
2004PI-22	PASADENA	230	PASADENA	115	1	2						
2004PI-22	ARIANA	230	ARIANA-N	69	1	16						
2004PI-22	SELOSE	230	SELOSE-N	69	1	16						
2004PI-22	GAPWAY	230	GAPWAY	69	1	16						
2004PI-22	CREWSLK	230	CREWSLK	69	1	13						
2004PI-22	TENOROC	230	TENOROC	69	1	13						
2004PI-22	BARCOLA	230	WEST	230	1	2						
2004PI-22	EATON PK	230	CREWSLK	230	1	13						
2004PI-22	EATON PK	230	EATON PK	69	1	13						
2004PI-22	EATON PK	230	TENOROC	230	1	13						
2004PI-22	RECKER	230	GAPWAY	230	1	16						
2004PI-22	SN PLANT	115	TURNER	115	1	1						
2004PI-23	SN PLANT	230	SYLVAN	230	1	1						
2004PI-23	SYLVAN	230	N LONGWD	230	1	1						
2004PI-23	IND RIV	230	STANTON	230	1	11						
2004PI-23	SN PLANT	115	TURNER	115	1	1						
2004PI-23	BUCKEYE	230	RUSKMTR8	230	1	1						
2004PI-23	SILVR SP	230	SILV SPN	230	1	2						
2004PI-23	SILVR SP	230	OCALA 1	230	1	2						
2004PI-23	RIO PINR	230	CURRY FD	230	1	2						
2004PI-23	STANTON	230	CURRY FD	230	1	2						
2004PI-23	OSCEOLA	230	LKAGNES	230	1	16						
2004PI-23	SHELD	230	LK TARP	230	1	2						
2004PI-23	PEBB	230	CREWSLK	230	1	13						
2004PI-23	PEBB	230	N BARTOW	230	1	2						
2004PI-23	RECKER	230	LKAGNES	230	1	16						
2004PI-23	RECKER	230	ARIANA	230	1	16						
2004PI-23	RECKER	230	CREWSLK	230	1	13						
2004PI-23	B BEND	230	MANATEE	230	1	1						
2004PI-23	RUSKIN T	230	MANATEE	230	1	1						
2004PI-23	IND RIV	230	IND RIV	115	1	11						
2004PI-23	SHELD	230	SHELD-NW	69	1	16						
2004PI-23	LARGO	230	LARGO A	69	1	2						
2004PI-23	CLMT EST	230	CLMT EST	69	1	2						
2004PI-23	11TH AVE	230	ELEVEN-E	69	1	16						
2004PI-23	WINDERME	230	WINDERME	69	1	2						
2004PI-23	PASADENA	230	PASADENA	115	1	2						
2004PI-23	ARIANA	230	ARIANA-N	69	1	16						
2004PI-23	SELOSE	230	SELOSE-N	69	1	16						
2004PI-23	GAPWAY	230	GAPWAY	69	1	16						
2004PI-23	CREWSLK	230	CREWSLK	69	1	13						
2004PI-23	TENOROC	230	TENOROC	69	1	13						
2004PI-23	BARCOLA	230	WEST	230	1	2						
2004PI-23	EATON PK	230	CREWSLK	230	1	13						
2004PI-23	EATON PK	230	EATON PK	69	1	13						
2004PI-23	EATON PK	230	TENOROC	230	1	13						
2004PI-23	RECKER	230	GAPWAY	230	1	16						
2004PI-23	SN PLANT	115	TURNER	115	1	1						

Table II
Comparison of Line & Transformer Flows
Following N-1 Disturbances
for Various OEC 500 MW Generation Alternatives

100% Load Base Case

All Flows above 100% of Emergency rating are Shown

Monitored Branches							Case 2004PI	Case 2004PIA	Case 2004PIB	Case 2004PIC	Case 2004PID	Case 2004PIE
Case	Bus 1	kV 1	Bus 2	kV 2	ckt	Area	Base No OEC Gen Percent	Sell to FPL Percent	Sell to FPC Percent	Sell to TEC Percent	Sell to JEA Percent	Sell to SEM Percent
2004PI-24	SN PLANT	230	SYLVAN	230	1	1						
2004PI-24	SYLVAN	230	N LONGWD	230	1	1						
2004PI-24	IND RIV	230	STANTON	230	1	11						
2004PI-24	SN PLANT	115	TURNER	115	1	1						
2004PI-24	BUCKEYE	230	RUSKMTR8	230	1	1						
2004PI-24	SILVR SP	230	SILV SPN	230	1	2						
2004PI-24	SILVR SP	230	OCALA 1	230	1	2						
2004PI-24	RIO PINR	230	CURRY FD	230	1	2						
2004PI-24	STANTON	230	CURRY FD	230	1	2						
2004PI-24	OSCEOLA	230	LKAGNES	230	1	16						
2004PI-24	SHELD	230	LK TARPEN	230	1	2						
2004PI-24	PEBB	230	CREWSLK	230	1	13						
2004PI-24	PEBB	230	N BARTOW	230	1	2						
2004PI-24	RECKER	230	LKAGNES	230	1	16						
2004PI-24	RECKER	230	ARIANA	230	1	16						
2004PI-24	RECKER	230	CREWSLK	230	1	13						
2004PI-24	B BEND	230	MANATEE	230	1	1						
2004PI-24	RUSKIN T	230	MANATEE	230	1	1						
2004PI-24	IND RIV	230	IND RIV	115	1	11						
2004PI-24	SHELD	230	SHELD-NW	69	1	16						
2004PI-24	LARGO	230	LARGO A	69	1	2						
2004PI-24	CLMT EST	230	CLMT EST	69	1	2						
2004PI-24	11TH AVE	230	ELEVEN-E	69	1	16						
2004PI-24	WINDERME	230	WINDERME	69	1	2						
2004PI-24	PASADENA	230	PASADENA	115	1	2						
2004PI-24	ARIANA	230	ARIANA-N	69	1	16						
2004PI-24	SELOSE	230	SELOSE-N	69	1	16						
2004PI-24	GAPWAY	230	GAPWAY	69	1	16						
2004PI-24	CREWSLK	230	CREWSLK	69	1	13						
2004PI-24	TENOROC	230	TENOROC	69	1	13						
2004PI-24	BARCOLA	230	WEST	230	1	2						
2004PI-24	EATON PK	230	CREWSLK	230	1	13						
2004PI-24	EATON PK	230	EATON PK	69	1	13						
2004PI-24	EATON PK	230	TENOROC	230	1	13						
2004PI-24	RECKER	230	GAPWAY	230	1	16						
2004PI-24	SN PLANT	115	TURNER	115	1	1						
2004PI-25	SN PLANT	230	SYLVAN	230	1	1						
2004PI-25	SYLVAN	230	N LONGWD	230	1	1						
2004PI-25	IND RIV	230	STANTON	230	1	11						
2004PI-25	SN PLANT	115	TURNER	115	1	1						
2004PI-25	BUCKEYE	230	RUSKMTR8	230	1	1						
2004PI-25	SILVR SP	230	SILV SPN	230	1	2						
2004PI-25	SILVR SP	230	OCALA 1	230	1	2						
2004PI-25	RIO PINR	230	CURRY FD	230	1	2						
2004PI-25	STANTON	230	CURRY FD	230	1	2						
2004PI-25	OSCEOLA	230	LKAGNES	230	1	16						
2004PI-25	SHELD	230	LK TARPEN	230	1	2						
2004PI-25	PEBB	230	CREWSLK	230	1	13						
2004PI-25	PEBB	230	N BARTOW	230	1	2						
2004PI-25	RECKER	230	LKAGNES	230	1	16						
2004PI-25	RECKER	230	ARIANA	230	1	16						
2004PI-25	RECKER	230	CREWSLK	230	1	13						
2004PI-25	B BEND	230	MANATEE	230	1	1						
2004PI-25	RUSKIN T	230	MANATEE	230	1	1						
2004PI-25	IND RIV	230	IND RIV	115	1	11						
2004PI-25	SHELD	230	SHELD-NW	69	1	16						
2004PI-25	LARGO	230	LARGO A	69	1	2						
2004PI-25	CLMT EST	230	CLMT EST	69	1	2						
2004PI-25	11TH AVE	230	ELEVEN-E	69	1	16						
2004PI-25	WINDERME	230	WINDERME	69	1	2						
2004PI-25	PASADENA	230	PASADENA	115	1	2						
2004PI-25	ARIANA	230	ARIANA-N	69	1	16						
2004PI-25	SELOSE	230	SELOSE-N	69	1	16						
2004PI-25	GAPWAY	230	GAPWAY	69	1	16						
2004PI-25	CREWSLK	230	CREWSLK	69	1	13						
2004PI-25	TENOROC	230	TENOROC	69	1	13						
2004PI-25	BARCOLA	230	WEST	230	1	2						
2004PI-25	EATON PK	230	CREWSLK	230	1	13						
2004PI-25	EATON PK	230	EATON PK	69	1	13						
2004PI-25	EATON PK	230	TENOROC	230	1	13						
2004PI-25	RECKER	230	GAPWAY	230	1	16						
2004PI-25	SN PLANT	115	TURNER	115	1	1						

Table II
Comparison of Line & Transformer Flows
Following N-1 Disturbances
for Various OEC 500 MW Generation Alternatives

100% Load Base Case

All Flows above 100% of Emergency rating are Shown

Monitored Branches							Case 2004PI	Case 2004PIA	Case 2004PIB	Case 2004PIC	Case 2004PID	Case 2004PIE
Case	Bus 1	kV 1	Bus 2	kV 2	ckt	Area	Base No OEC Gen Percent	Sell to FPL Percent	Sell to FPC Percent	Sell to TEC Percent	Sell to JEA Percent	Sell to SEM Percent
2004PI-26	SN PLANT	230	SYLVAN	230	1	1						
2004PI-26	SYLVAN	230	N LONGWD	230	1	1						
2004PI-26	IND RIV	230	STANTON	230	1	11						
2004PI-26	SN PLANT	115	TURNER	115	1	1						
2004PI-26	BUCKEYE	230	RUSKMTR8	230	1	1						
2004PI-26	SILVR SP	230	SILV SPN	230	1	2						
2004PI-26	SILVR SP	230	OCALA 1	230	1	2						
2004PI-26	RIO PINR	230	CURRY FD	230	1	2						
2004PI-26	STANTON	230	CURRY FD	230	1	2						
2004PI-26	OSCEOLA	230	LKAGNES	230	1	16						
2004PI-26	SHELD	230	LK TARP	230	1	2						
2004PI-26	PEBB	230	CREWSLK	230	1	13						
2004PI-26	PEBB	230	N BARTOW	230	1	2						
2004PI-26	RECKER	230	LKAGNES	230	1	16						
2004PI-26	RECKER	230	ARIANA	230	1	16						
2004PI-26	RECKER	230	CREWSLK	230	1	13						
2004PI-26	B BEND	230	MANATEE	230	1	1						
2004PI-26	RUSKIN T	230	MANATEE	230	1	1						
2004PI-26	IND RIV	230	IND RIV	115	1	11						
2004PI-26	SHELD	230	SHELD-NW	69	1	16						
2004PI-26	LARGO	230	LARGO A	69	1	2						
2004PI-26	CLMT EST	230	CLMT EST	69	1	2						
2004PI-26	11TH AVE	230	ELEVEN-E	69	1	16						
2004PI-26	WINDERME	230	WINDERME	69	1	2						
2004PI-26	PASADENA	230	PASADENA	115	1	2						
2004PI-26	ARIANA	230	ARIANA-N	69	1	16						
2004PI-26	SELOSE	230	SELOSE-N	69	1	16						
2004PI-26	GAPWAY	230	GAPWAY	69	1	16						
2004PI-26	CREWSLK	230	CREWSLK	69	1	13						
2004PI-26	TENOROC	230	TENOROC	69	1	13						
2004PI-26	BARCOLA	230	WEST	230	1	2						
2004PI-26	EATON PK	230	CREWSLK	230	1	13						
2004PI-26	EATON PK	230	EATON PK	69	1	13						
2004PI-26	EATON PK	230	TENOROC	230	1	13						
2004PI-26	RECKER	230	GAPWAY	230	1	16						
2004PI-26	SN PLANT	115	TURNER	115	1	1						
2004PI-27	SN PLANT	230	SYLVAN	230	1	1						
2004PI-27	SYLVAN	230	N LONGWD	230	1	1						
2004PI-27	IND RIV	230	STANTON	230	1	11						
2004PI-27	SN PLANT	115	TURNER	115	1	1						
2004PI-27	BUCKEYE	230	RUSKMTR8	230	1	1						
2004PI-27	SILVR SP	230	SILV SPN	230	1	2						
2004PI-27	SILVR SP	230	OCALA 1	230	1	2						
2004PI-27	RIO PINR	230	CURRY FD	230	1	2						
2004PI-27	STANTON	230	CURRY FD	230	1	2						
2004PI-27	OSCEOLA	230	LKAGNES	230	1	16						
2004PI-27	SHELD	230	LK TARP	230	1	2						
2004PI-27	PEBB	230	CREWSLK	230	1	13						
2004PI-27	PEBB	230	N BARTOW	230	1	2						
2004PI-27	RECKER	230	LKAGNES	230	1	16						
2004PI-27	RECKER	230	ARIANA	230	1	16						
2004PI-27	RECKER	230	CREWSLK	230	1	13						
2004PI-27	B BEND	230	MANATEE	230	1	1						
2004PI-27	RUSKIN T	230	MANATEE	230	1	1						
2004PI-27	IND RIV	230	IND RIV	115	1	11						
2004PI-27	SHELD	230	SHELD-NW	69	1	16						
2004PI-27	LARGO	230	LARGO A	69	1	2						
2004PI-27	CLMT EST	230	CLMT EST	69	1	2						
2004PI-27	11TH AVE	230	ELEVEN-E	69	1	16						
2004PI-27	WINDERME	230	WINDERME	69	1	2						
2004PI-27	PASADENA	230	PASADENA	115	1	2						
2004PI-27	ARIANA	230	ARIANA-N	69	1	16						
2004PI-27	SELOSE	230	SELOSE-N	69	1	16						
2004PI-27	GAPWAY	230	GAPWAY	69	1	16						
2004PI-27	CREWSLK	230	CREWSLK	69	1	13						
2004PI-27	TENOROC	230	TENOROC	69	1	13						
2004PI-27	BARCOLA	230	WEST	230	1	2						
2004PI-27	EATON PK	230	CREWSLK	230	1	13						
2004PI-27	EATON PK	230	EATON PK	69	1	13						
2004PI-27	EATON PK	230	TENOROC	230	1	13						
2004PI-27	RECKER	230	GAPWAY	230	1	16						
2004PI-27	SN PLANT	115	TURNER	115	1	1						

Table II
Comparison of Line & Transformer Flows
Following N-1 Disturbances
for Various OEC 500 MW Generation Alternatives

100% Load Base Case

All Flows above 100% of Emergency rating are Shown

Monitored Branches							Case 2004PI	Case 2004PIA	Case 2004PIB	Case 2004PIC	Case 2004PID	Case 2004PIE
Case	Bus 1	kV 1	Bus 2	kV 2	ckt	Area	Base No OEC Gen Percent	Sell to FPL Percent	Sell to FPC Percent	Sell to TEC Percent	Sell to JEA Percent	Sell to SEM Percent
2004PI-28	SN PLANT	230	SYLVAN	230	1	1						
2004PI-28	SYLVAN	230	N LONGWD	230	1	1						
2004PI-28	IND RIV	230	STANTON	230	1	11						
2004PI-28	SN PLANT	115	TURNER	115	1	1						
2004PI-28	BUCKEYE	230	RUSKMTR8	230	1	1						
2004PI-28	SILVR SP	230	SILV SPN	230	1	2						
2004PI-28	SILVR SP	230	OCALA 1	230	1	2						
2004PI-28	RIO PINR	230	CURRY FD	230	1	2						
2004PI-28	STANTON	230	CURRY FD	230	1	2						
2004PI-28	OSCEOLA	230	LKAGNES	230	1	16						
2004PI-28	SHELD	230	LK TARP	230	1	2						
2004PI-28	PEBB	230	CREWSLK	230	1	13						
2004PI-28	PEBB	230	N BARTOW	230	1	2						
2004PI-28	RECKER	230	LKAGNES	230	1	16						
2004PI-28	RECKER	230	ARIANA	230	1	16						
2004PI-28	RECKER	230	CREWSLK	230	1	13						
2004PI-28	B BEND	230	MANATEE	230	1	1						
2004PI-28	RUSKIN T	230	MANATEE	230	1	1						
2004PI-28	IND RIV	230	IND RIV	115	1	11						
2004PI-28	SHELD	230	SHELD-NW	69	1	16						
2004PI-28	LARGO	230	LARGO A	69	1	2						
2004PI-28	CLMT EST	230	CLMT EST	69	1	2						
2004PI-28	11TH AVE	230	ELEVEN-E	69	1	16						
2004PI-28	WINDERME	230	WINDERME	69	1	2						
2004PI-28	PASADENA	230	PASADENA	115	1	2						
2004PI-28	ARIANA	230	ARIANA-N	69	1	16						
2004PI-28	SELOSE	230	SELOSE-N	69	1	16						
2004PI-28	GAPWAY	230	GAPWAY	69	1	16						
2004PI-28	CREWSLK	230	CREWSLK	69	1	13						
2004PI-28	TENOROC	230	TENOROC	69	1	13						
2004PI-28	BARCOLA	230	WEST	230	1	2						
2004PI-28	EATON PK	230	CREWSLK	230	1	13						
2004PI-28	EATON PK	230	EATON PK	69	1	13						
2004PI-28	EATON PK	230	TENOROC	230	1	13						
2004PI-28	RECKER	230	GAPWAY	230	1	16						
2004PI-28	SN PLANT	115	TURNER	115	1	1						
2004PI-29	SN PLANT	230	SYLVAN	230	1	1						
2004PI-29	SYLVAN	230	N LONGWD	230	1	1						
2004PI-29	IND RIV	230	STANTON	230	1	11						
2004PI-29	SN PLANT	115	TURNER	115	1	1						
2004PI-29	BUCKEYE	230	RUSKMTR8	230	1	1						
2004PI-29	SILVR SP	230	SILV SPN	230	1	2						
2004PI-29	SILVR SP	230	OCALA 1	230	1	2						
2004PI-29	RIO PINR	230	CURRY FD	230	1	2						
2004PI-29	STANTON	230	CURRY FD	230	1	2						
2004PI-29	OSCEOLA	230	LKAGNES	230	1	16						
2004PI-29	SHELD	230	LK TARP	230	1	2						
2004PI-29	PEBB	230	CREWSLK	230	1	13						
2004PI-29	PEBB	230	N BARTOW	230	1	2						
2004PI-29	RECKER	230	LKAGNES	230	1	16						
2004PI-29	RECKER	230	ARIANA	230	1	16						
2004PI-29	RECKER	230	CREWSLK	230	1	13						
2004PI-29	B BEND	230	MANATEE	230	1	1						
2004PI-29	RUSKIN T	230	MANATEE	230	1	1						
2004PI-29	IND RIV	230	IND RIV	115	1	11						
2004PI-29	SHELD	230	SHELD-NW	69	1	16						
2004PI-29	LARGO	230	LARGO A	69	1	2						
2004PI-29	CLMT EST	230	CLMT EST	69	1	2						
2004PI-29	11TH AVE	230	ELEVEN-E	69	1	16						
2004PI-29	WINDERME	230	WINDERME	69	1	2						
2004PI-29	PASADENA	230	PASADENA	115	1	2						
2004PI-29	ARIANA	230	ARIANA-N	69	1	16		104.2	103.9	104.6	103.8	103.8
2004PI-29	SELOSE	230	SELOSE-N	69	1	16						
2004PI-29	GAPWAY	230	GAPWAY	69	1	16						
2004PI-29	CREWSLK	230	CREWSLK	69	1	13						
2004PI-29	TENOROC	230	TENOROC	69	1	13						
2004PI-29	BARCOLA	230	WEST	230	1	2						
2004PI-29	EATON PK	230	CREWSLK	230	1	13						
2004PI-29	EATON PK	230	EATON PK	69	1	13						
2004PI-29	EATON PK	230	TENOROC	230	1	13						
2004PI-29	RECKER	230	GAPWAY	230	1	16						
2004PI-29	SN PLANT	115	TURNER	115	1	1						

Table II
Comparison of Line & Transformer Flows
Following N-1 Disturbances
for Various OEC 500 MW Generation Alternatives

100% Load Base Case

All Flows above 100% of Emergency rating are Shown

Monitored Branches							Case 2004PI Base No OEC Gen	Case 2004PIA Sell to FPL	Case 2004PIB Sell to FPC	Case 2004PIC Sell to TEC	Case 2004PID Sell to JEA	Case 2004PIE Sell to SEM
Case	Bus 1	kV 1	Bus 2	kV 2	ckt	Area	Percent	Percent	Percent	Percent	Percent	Percent
2004PI-30	SN PLANT	230	SYLVAN	230	1	1						
2004PI-30	SYLVAN	230	N LONGWD	230	1	1						
2004PI-30	IND RIV	230	STANTON	230	1	11						
2004PI-30	SN PLANT	115	TURNER	115	1	1						
2004PI-30	BUCKEYE	230	RUSKMTR8	230	1	1						
2004PI-30	SILVR SP	230	SILV SPN	230	1	2						
2004PI-30	SILVR SP	230	OCALA 1	230	1	2						
2004PI-30	RIO PINR	230	CURRY FD	230	1	2						
2004PI-30	STANTON	230	CURRY FD	230	1	2						
2004PI-30	OSCEOLA	230	LKAGNES	230	1	16						
2004PI-30	SHELD	230	LK TARP	230	1	2						
2004PI-30	PEBB	230	CREWSLK	230	1	13						
2004PI-30	PEBB	230	N BARTOW	230	1	2						
2004PI-30	RECKER	230	LKAGNES	230	1	16						
2004PI-30	RECKER	230	ARIANA	230	1	16						
2004PI-30	RECKER	230	CREWSLK	230	1	13						
2004PI-30	B BEND	230	MANATEE	230	1	1						
2004PI-30	RUSKIN T	230	MANATEE	230	1	1						
2004PI-30	IND RIV	230	IND RIV	115	1	11						
2004PI-30	SHELD	230	SHELD-NW	69	1	16						
2004PI-30	LARGO	230	LARGO A	69	1	2						
2004PI-30	CLMT EST	230	CLMT EST	69	1	2						
2004PI-30	11TH AVE	230	ELEVEN-E	69	1	16						
2004PI-30	WINDERME	230	WINDERME	69	1	2						
2004PI-30	PASADENA	230	PASADENA	115	1	2						
2004PI-30	ARIANA	230	ARIANA-N	69	1	16						
2004PI-30	SELOSE	230	SELOSE-N	69	1	16						
2004PI-30	GAPWAY	230	GAPWAY	69	1	16						
2004PI-30	CREWSLK	230	CREWSLK	69	1	13						
2004PI-30	TENOROC	230	TENOROC	69	1	13						
2004PI-30	BARCOLA	230	WEST	230	1	2						
2004PI-30	EATON PK	230	CREWSLK	230	1	13						
2004PI-30	EATON PK	230	EATON PK	69	1	13						
2004PI-30	EATON PK	230	TENOROC	230	1	13						
2004PI-30	RECKER	230	GAPWAY	230	1	16						
2004PI-30	SN PLANT	115	TURNER	115	1	1						
2004PI-31	SN PLANT	230	SYLVAN	230	1	1						
2004PI-31	SYLVAN	230	N LONGWD	230	1	1						
2004PI-31	IND RIV	230	STANTON	230	1	11						
2004PI-31	SN PLANT	115	TURNER	115	1	1						
2004PI-31	BUCKEYE	230	RUSKMTR8	230	1	1						
2004PI-31	SILVR SP	230	SILV SPN	230	1	2						
2004PI-31	SILVR SP	230	OCALA 1	230	1	2						
2004PI-31	RIO PINR	230	CURRY FD	230	1	2						
2004PI-31	STANTON	230	CURRY FD	230	1	2						
2004PI-31	OSCEOLA	230	LKAGNES	230	1	16						
2004PI-31	SHELD	230	LK TARP	230	1	2						
2004PI-31	PEBB	230	CREWSLK	230	1	13						
2004PI-31	PEBB	230	N BARTOW	230	1	2						
2004PI-31	RECKER	230	LKAGNES	230	1	16						
2004PI-31	RECKER	230	ARIANA	230	1	16						
2004PI-31	RECKER	230	CREWSLK	230	1	13						
2004PI-31	B BEND	230	MANATEE	230	1	1						
2004PI-31	RUSKIN T	230	MANATEE	230	1	1						
2004PI-31	IND RIV	230	IND RIV	115	1	11						
2004PI-31	SHELD	230	SHELD-NW	69	1	16						
2004PI-31	LARGO	230	LARGO A	69	1	2						
2004PI-31	CLMT EST	230	CLMT EST	69	1	2						
2004PI-31	11TH AVE	230	ELEVEN-E	69	1	16						
2004PI-31	WINDERME	230	WINDERME	69	1	2						
2004PI-31	PASADENA	230	PASADENA	115	1	2						
2004PI-31	ARIANA	230	ARIANA-N	69	1	16						
2004PI-31	SELOSE	230	SELOSE-N	69	1	16						
2004PI-31	GAPWAY	230	GAPWAY	69	1	16						
2004PI-31	CREWSLK	230	CREWSLK	69	1	13						
2004PI-31	TENOROC	230	TENOROC	69	1	13						
2004PI-31	BARCOLA	230	WEST	230	1	2						
2004PI-31	EATON PK	230	CREWSLK	230	1	13						
2004PI-31	EATON PK	230	EATON PK	69	1	13						
2004PI-31	EATON PK	230	TENOROC	230	1	13						
2004PI-31	RECKER	230	GAPWAY	230	1	16						
2004PI-31	SN PLANT	115	TURNER	115	1	1						

Table II
Comparison of Line & Transformer Flows
Following N-1 Disturbances
for Various OEC 500 MW Generation Alternatives

100% Load Base Case

All Flows above 100% of Emergency rating are Shown

Monitored Branches							Case 2004PI Base No OEC Gen	Case 2004PIA Sell to FPL	Case 2004PIB Sell to FPC	Case 2004PIC Sell to TEC	Case 2004PID Sell to JEA	Case 2004PIE Sell to SEM
Case	Bus 1	kV 1	Bus 2	kV 2	ckt	Area	Percent	Percent	Percent	Percent	Percent	Percent
2004PI-32	SN PLANT	230	SYLVAN	230	1	1						
2004PI-32	SYLVAN	230	N LONGWD	230	1	1						
2004PI-32	IND RIV	230	STANTON	230	1	11						
2004PI-32	SN PLANT	115	TURNER	115	1	1						
2004PI-32	BUCKEYE	230	RUSKMTR8	230	1	1						
2004PI-32	SILVR SP	230	SILV SPN	230	1	2						
2004PI-32	SILVR SP	230	OCALA 1	230	1	2						
2004PI-32	RIO PINR	230	CURRY FD	230	1	2						
2004PI-32	STANTON	230	CURRY FD	230	1	2						
2004PI-32	OSCEOLA	230	LKAGNES	230	1	16						
2004PI-32	SHELD	230	LK TARPEN	230	1	2						
2004PI-32	PEBB	230	CREWSLK	230	1	13						
2004PI-32	PEBB	230	N BARTOW	230	1	2						
2004PI-32	RECKER	230	LKAGNES	230	1	16						
2004PI-32	RECKER	230	ARIANA	230	1	16						
2004PI-32	RECKER	230	CREWSLK	230	1	13						
2004PI-32	B BEND	230	MANATEE	230	1	1						
2004PI-32	RUSKIN T	230	MANATEE	230	1	1						
2004PI-32	IND RIV	230	IND RIV	115	1	11						
2004PI-32	SHELD	230	SHELD-NW	69	1	16						
2004PI-32	LARGO	230	LARGO A	69	1	2						
2004PI-32	CLMT EST	230	CLMT EST	69	1	2						
2004PI-32	11TH AVE	230	ELEVEN-E	69	1	16						
2004PI-32	WINDERME	230	WINDERME	69	1	2						
2004PI-32	PASADENA	230	PASADENA	115	1	2						
2004PI-32	ARIANA	230	ARIANA-N	69	1	16						
2004PI-32	SELOSE	230	SELOSE-N	69	1	16						
2004PI-32	GAPWAY	230	GAPWAY	69	1	16						
2004PI-32	CREWSLK	230	CREWSLK	69	1	13						
2004PI-32	TENOROC	230	TENOROC	69	1	13						
2004PI-32	BARCOLA	230	WEST	230	1	2						
2004PI-32	EATON PK	230	CREWSLK	230	1	13						
2004PI-32	EATON PK	230	EATON PK	69	1	13						
2004PI-32	EATON PK	230	TENOROC	230	1	13						
2004PI-32	RECKER	230	GAPWAY	230	1	16						
2004PI-32	SN PLANT	115	TURNER	115	1	1						
2004PI-33	SN PLANT	230	SYLVAN	230	1	1						
2004PI-33	SYLVAN	230	N LONGWD	230	1	1						
2004PI-33	IND RIV	230	STANTON	230	1	11						
2004PI-33	SN PLANT	115	TURNER	115	1	1						
2004PI-33	BUCKEYE	230	RUSKMTR8	230	1	1						
2004PI-33	SILVR SP	230	SILV SPN	230	1	2						
2004PI-33	SILVR SP	230	OCALA 1	230	1	2						
2004PI-33	RIO PINR	230	CURRY FD	230	1	2						
2004PI-33	STANTON	230	CURRY FD	230	1	2						
2004PI-33	OSCEOLA	230	LKAGNES	230	1	16						
2004PI-33	SHELD	230	LK TARPEN	230	1	2						
2004PI-33	PEBB	230	CREWSLK	230	1	13						
2004PI-33	PEBB	230	N BARTOW	230	1	2						
2004PI-33	RECKER	230	LKAGNES	230	1	16						
2004PI-33	RECKER	230	ARIANA	230	1	16						
2004PI-33	RECKER	230	CREWSLK	230	1	13						
2004PI-33	B BEND	230	MANATEE	230	1	1						
2004PI-33	RUSKIN T	230	MANATEE	230	1	1						
2004PI-33	IND RIV	230	IND RIV	115	1	11						
2004PI-33	SHELD	230	SHELD-NW	69	1	16						
2004PI-33	LARGO	230	LARGO A	69	1	2						
2004PI-33	CLMT EST	230	CLMT EST	69	1	2						
2004PI-33	11TH AVE	230	ELEVEN-E	69	1	16						
2004PI-33	WINDERME	230	WINDERME	69	1	2						
2004PI-33	PASADENA	230	PASADENA	115	1	2						
2004PI-33	ARIANA	230	ARIANA-N	69	1	16						
2004PI-33	SELOSE	230	SELOSE-N	69	1	16						
2004PI-33	GAPWAY	230	GAPWAY	69	1	16						
2004PI-33	CREWSLK	230	CREWSLK	69	1	13						
2004PI-33	TENOROC	230	TENOROC	69	1	13						
2004PI-33	BARCOLA	230	WEST	230	1	2						
2004PI-33	EATON PK	230	CREWSLK	230	1	13						
2004PI-33	EATON PK	230	EATON PK	69	1	13						
2004PI-33	EATON PK	230	TENOROC	230	1	13						
2004PI-33	RECKER	230	GAPWAY	230	1	16						
2004PI-33	SN PLANT	115	TURNER	115	1	1						

Table II
Comparison of Line & Transformer Flows
Following N-1 Disturbances
for Various OEC 500 MW Generation Alternatives

100% Load Base Case

All Flows above 100% of Emergency rating are Shown

Monitored Branches							Case 2004PI	Case 2004PIA	Case 2004PIB	Case 2004PIC	Case 2004PID	Case 2004PIE
Case	Bus 1	kV 1	Bus 2	kV 2	ckt	Area	Base No OEC Gen Percent	Sell to FPL Percent	Sell to FPC Percent	Sell to TEC Percent	Sell to JEA Percent	Sell to SEM Percent
2004PI-34	SN PLANT	230	SYLVAN	230	1	1						
2004PI-34	SYLVAN	230	N LONGWD	230	1	1						
2004PI-34	IND RIV	230	STANTON	230	1	11						
2004PI-34	SN PLANT	115	TURNER	115	1	1						
2004PI-34	BUCKEYE	230	RUSKMTR8	230	1	1						
2004PI-34	SILVR SP	230	SILV SPN	230	1	2						
2004PI-34	SILVR SP	230	OCALA 1	230	1	2						
2004PI-34	RIO PINR	230	CURRY FD	230	1	2						
2004PI-34	STANTON	230	CURRY FD	230	1	2						
2004PI-34	OSCEOLA	230	LKAGNES	230	1	16						
2004PI-34	SHELD	230	LK TARP	230	1	2						
2004PI-34	PEBB	230	CREWSLK	230	1	13						
2004PI-34	PEBB	230	N BARTOW	230	1	2						
2004PI-34	RECKER	230	LKAGNES	230	1	16						
2004PI-34	RECKER	230	ARIANA	230	1	16						
2004PI-34	RECKER	230	CREWSLK	230	1	13						
2004PI-34	B BEND	230	MANATEE	230	1	1						
2004PI-34	RUSKIN T	230	MANATEE	230	1	1						
2004PI-34	IND RIV	230	IND RIV	115	1	11						
2004PI-34	SHELD	230	SHELD-NW	69	1	16						
2004PI-34	LARGO	230	LARGO A	69	1	2						
2004PI-34	CLMT EST	230	CLMT EST	69	1	2						
2004PI-34	11TH AVE	230	ELEVEN-E	69	1	16						
2004PI-34	WINDERME	230	WINDERME	69	1	2						
2004PI-34	PASADENA	230	PASADENA	115	1	2						
2004PI-34	ARIANA	230	ARIANA-N	69	1	16						
2004PI-34	SELOSE	230	SELOSE-N	69	1	16						
2004PI-34	GAPWAY	230	GAPWAY	69	1	16						
2004PI-34	CREWSLK	230	CREWSLK	69	1	13						
2004PI-34	TENOROC	230	TENOROC	69	1	13						
2004PI-34	BARCOLA	230	WEST	230	1	2						
2004PI-34	EATON PK	230	CREWSLK	230	1	13						
2004PI-34	EATON PK	230	EATON PK	69	1	13						
2004PI-34	EATON PK	230	TENOROC	230	1	13						
2004PI-34	RECKER	230	GAPWAY	230	1	16						
2004PI-34	SN PLANT	115	TURNER	115	1	1						
2004PI-35	SN PLANT	230	SYLVAN	230	1	1						
2004PI-35	SYLVAN	230	N LONGWD	230	1	1						
2004PI-35	IND RIV	230	STANTON	230	1	11						
2004PI-35	SN PLANT	115	TURNER	115	1	1						
2004PI-35	BUCKEYE	230	RUSKMTR8	230	1	1						
2004PI-35	SILVR SP	230	SILV SPN	230	1	2						
2004PI-35	SILVR SP	230	OCALA 1	230	1	2						
2004PI-35	RIO PINR	230	CURRY FD	230	1	2						
2004PI-35	STANTON	230	CURRY FD	230	1	2						
2004PI-35	OSCEOLA	230	LKAGNES	230	1	16						
2004PI-35	SHELD	230	LK TARP	230	1	2						
2004PI-35	PEBB	230	CREWSLK	230	1	13						
2004PI-35	PEBB	230	N BARTOW	230	1	2						
2004PI-35	RECKER	230	LKAGNES	230	1	16						
2004PI-35	RECKER	230	ARIANA	230	1	16						
2004PI-35	RECKER	230	CREWSLK	230	1	13						
2004PI-35	B BEND	230	MANATEE	230	1	1						
2004PI-35	RUSKIN T	230	MANATEE	230	1	1						
2004PI-35	IND RIV	230	IND RIV	115	1	11						
2004PI-35	SHELD	230	SHELD-NW	69	1	16						
2004PI-35	LARGO	230	LARGO A	69	1	2						
2004PI-35	CLMT EST	230	CLMT EST	69	1	2						
2004PI-35	11TH AVE	230	ELEVEN-E	69	1	16						
2004PI-35	WINDERME	230	WINDERME	69	1	2						
2004PI-35	PASADENA	230	PASADENA	115	1	2						
2004PI-35	ARIANA	230	ARIANA-N	69	1	16						
2004PI-35	SELOSE	230	SELOSE-N	69	1	16						
2004PI-35	GAPWAY	230	GAPWAY	69	1	16						
2004PI-35	CREWSLK	230	CREWSLK	69	1	13						
2004PI-35	TENOROC	230	TENOROC	69	1	13						
2004PI-35	BARCOLA	230	WEST	230	1	2						
2004PI-35	EATON PK	230	CREWSLK	230	1	13						
2004PI-35	EATON PK	230	EATON PK	69	1	13						
2004PI-35	EATON PK	230	TENOROC	230	1	13						
2004PI-35	RECKER	230	GAPWAY	230	1	16						
2004PI-35	SN PLANT	115	TURNER	115	1	1						

APPENDIX I-A

RECKER
9100

←74.0

←20.4

←38.0

→25.9

←105.5

←7.1

←40.4

←8.3

→109.2

←15.9

1

-0.1 233

235.7
1.025

CREWSLK
6105

237.1
1.031

1.000

→82.3
→7.8

1.000
1.025

6045 CREWSLK
70.72

→58.6
→18.1

1.029

6103 EATON PK
236.8

→91.8
→48.1

1.038

9050 FEBB
238.8

1.000
APP-CT
7961

14.04
1.018

APP-ST
7962

13.96
1.012

ARIANA
9110

235.6
1.024

→105.8
→7.4

1.000
1.018

9102 ARIANA-N
70.23

LKAGNES
9150

236.3
1.027

→256.7
→2.9

1.032

6101 MCINTOSH
237.4

→294.7
→19.7

1.026

7890 OSCEOLA
235.9

GAPWAY
9160

235.2
1.023

→74.0
→21.4

1.000
1.022

9162 GAPWAY
70.51

2004pl.sav

P mis = -0.0019 MW

Q mis = -0.0021 MVAR



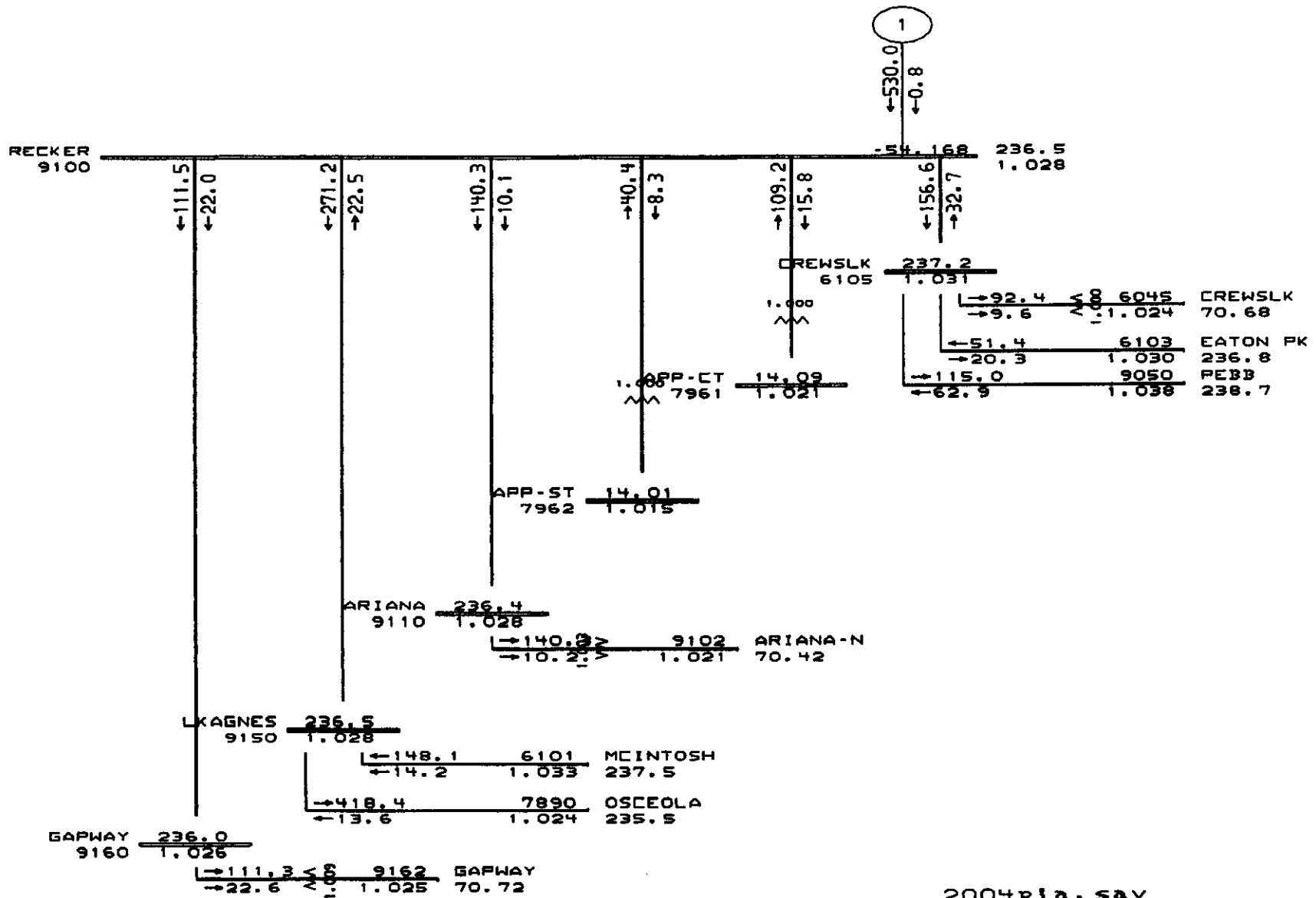

2004pia.sav
 P mis = -0.0019 MW
 Q mis = 0.0009 MVAR



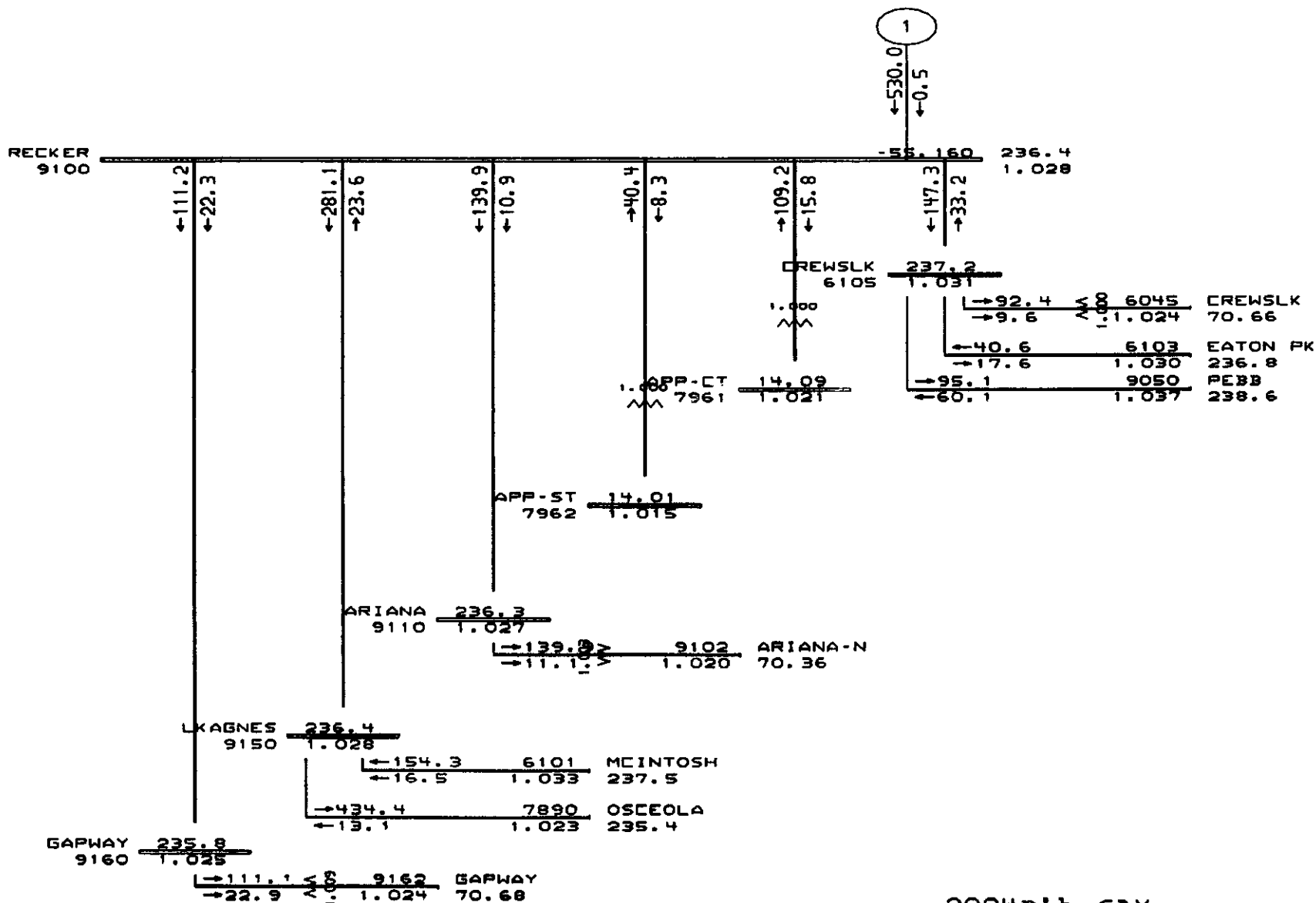

2004plb.sav
 P mis = -0.0004 MW
 Q mis = 0.0001 MVAR



PSJ Progress
 FERC 2004 SUMMER BASE CASE - FY1998 - REVISION 5
 PROPOSED OSPREY ENERGY CENTER

MM/MMR Fri Feb 25 10:11:25 2000

2004plb.sav
 Rating = 1

RECKER
9100

←111.2
←22.3

←281.1
→23.6

←139.9
←10.9

→40.4
←8.3

→109.2
←15.8

1
←530.0
←0.5

236.4
1.028

CREWSLK
6105

237.2
1.031

1.000
^^

→92.4
→9.6

6045
1.1.024

CREWSLK
70.66

←40.6
→17.6

6103
1.030

EATON PK
236.8

→95.1
→60.1

9050
1.037

PEBB
238.6

1.000
^^

APP-CT
7961

14.09
1.021

APP-ST
7962

14.01
1.015

ARIANA
9110

236.3
1.027

→139.8
→11.1

9102
1.020

ARIANA-N
70.36

LKAGNES
9150

236.4
1.028

←154.3
←16.5

6101
1.033

MCINTOSH
237.5

→434.4
←13.1

7890
1.023

OSCEOLA
235.4

GAPWAY
9160

235.8
1.025

→111.1
→22.9

9162
1.024

GAPWAY
70.68

2004plb.sav

P mis = -0.0004 MW

Q mis = 0.0001 MVAR



RECKER
9100

←112.3

←21.6

←252.3

→24.9

←140.7

←9.4

→40.4

←8.3

→109.2

←15.8

1

←530.0
←0.1

←55.8

800

←174.2

→30.1

236.5
1.028

CREWSLK
6105

237.0
1.031

→94.1

→10.2

←1.000

6045

1.023

CREWSLK
70.59

←63.6

→17.8

←1.029

6103

1.029

EATON PK
236.7

→143.0

←59.8

←1.036

9050

1.036

PEBB
238.3

APP-CT
7961

14.09
1.021

APP-ST
7962

14.01
1.015

ARIANA
9110

236.4
1.028

→140.8

→9.6

←1.021

9102

1.021

ARIANA-N
70.45

LKAGNES
9150

236.6
1.029

←126.1

←14.4

←1.033

6101

1.033

MCINTOSH
237.5

→377.6

←14.5

←1.025

7890

1.025

OSCEOLA
235.7

GAPWAY
9160

236.0
1.026

→112.2

→22.2

←1.025

9162

1.025

GAPWAY
70.74

2004pic.sav

P mis = 0.0007 MW

Q mis = 0.0019 MVAR

General Electric Company

PLP Program

FERC 2004 SUMMER BASE CASE - FY1998 - REVISION 5
PROPOSED OSPREY ENERGY CENTER

M/MVAR

Fri Feb 25 10:11:58 2000



GENERAL
ELECTRIC
COMPANY

2004pic.sav
Rating = 1

RECKER
9100

←111.2

←21.8

←280.2

→22.4

←139.8

←9.9

→40.4

←8.3

→109.2

←15.8

1
←530.0
←0.5

←48.721

236.5
1.028

←148.4

→33.0

CREWSLK
6105

237.2
1.031

1.000
ΛΛ

→92.3
→9.5

1.000
ΛΛ

6045 CREWSLK
70.69

←41.6
→19.2

1.030
ΛΛ

6103 EATON PK
236.8

→97.2
←61.5

1.038
ΛΛ

9050 PEBB
238.7

1.000
ΛΛ

APP-CT 14.09
7961 1.021

APP-ST 14.01
7962 1.015

ARIANA 236.4
9110 1.028

→139.8
→10.1

9102 ARIANA-N
70.42 1.021

LKAGNES 236.4
9150 1.028

←153.4
←15.1

6101 MCINTOSH
237.5 1.033

→432.7
←113.1

7890 OSCEOLA
235.4 1.024

GAPWAY 235.9
9160 1.028

→111.0
→22.4

1.000
ΛΛ

9162 GAPWAY
70.72 1.025

2004pld.sav
P mis = -0.0008 MW
Q mis = -0.0037 MVAR



PSLF Program
FERC 2004 SUMMER RASE CASE - FY1998 - REVISION 5
PROPOSED OSPREY ENERGY CENTER

MW/MVAR Fri Feb 25 10:12:11 2000

2004pld.sav
Rating = 1

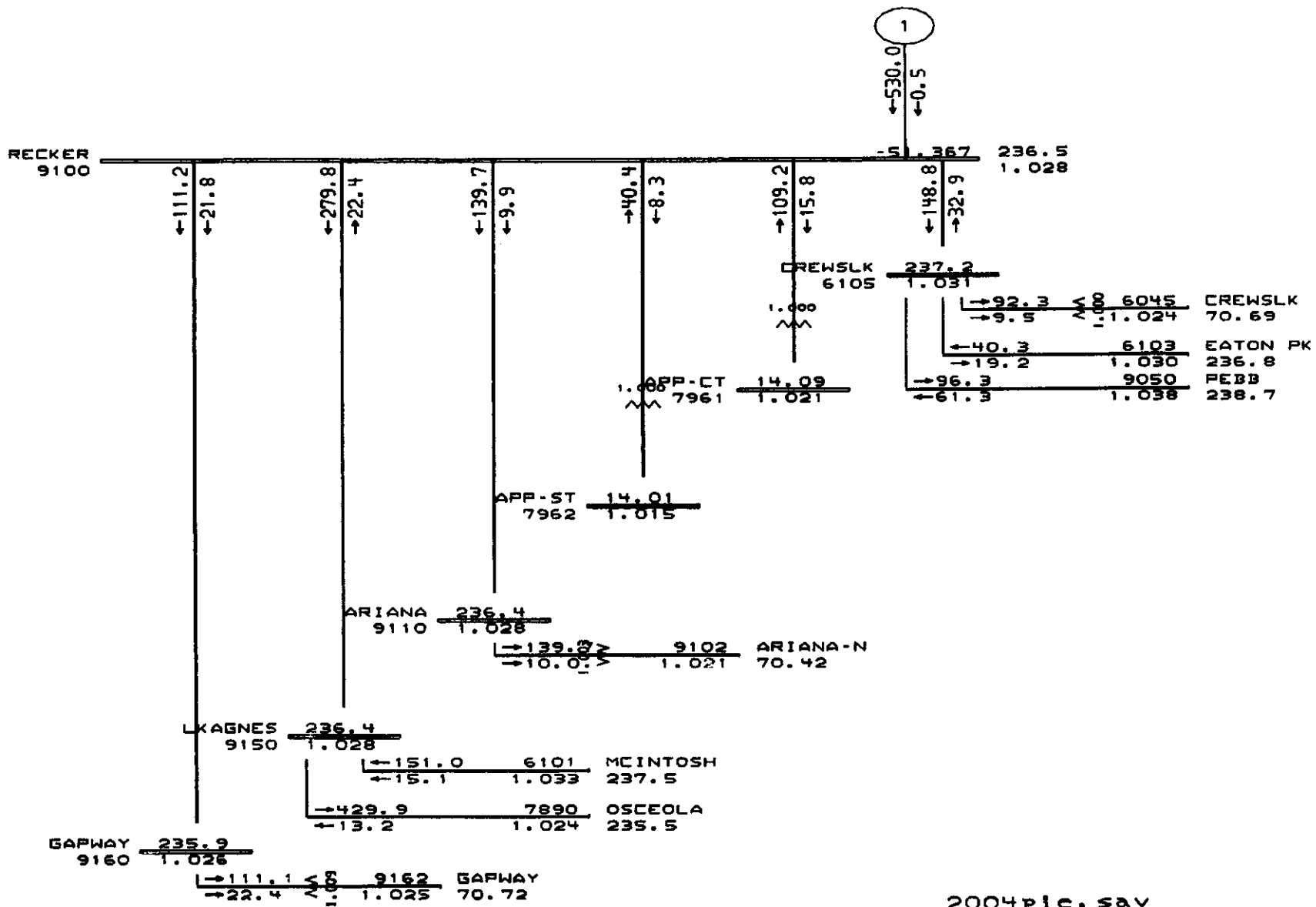

2004pic.sav
P mis = 0.0005 MW
Q mis = -0.0027 MVAR



RECKER
9100

1

←60.7
→20.4

←134.6
←17.7

→40.4
←8.3

→109.2
←15.8

←50.9
236.1
1.027

CREWSLK
6105

237.2
1.031

→86.2
→8.4

←60.4
←20.0

6045
70.73

EATON PK
236.8

9050
238.8

1.000
APP-ET
7961

14.07
1.019

APP-ST
7962

13.99
1.014

ARIANA
9110

236.0
1.026

→134.8
→17.9

9102
1.014

ARIANA-N
69.98

LKAGNES
9150

236.5
1.028

←238.3
→0.3

6101
1.032

MCINTOSH
237.5

→299.0
←17.7

7890
1.026

OSCEOLA
235.9

GAPWAY
9160

229.8
0.999

←0.0
←0.0

9162
1.008

GAPWAY
69.55

2004pi.sav
P mis = -0.0019 MW
Q mis = -0.0021 MVAR

General Electric Company

PSLF Program



GENERAL
ELECTRIC
COMPANY

FERC 2004 SUMMER BASE CASE - FY1998 - REVISION 5
PROPOSED OSPREY ENERGY CENTER

HM/RMR

Wed Feb 16 14:57:33 2000

2004pi.sav
Rating = 1

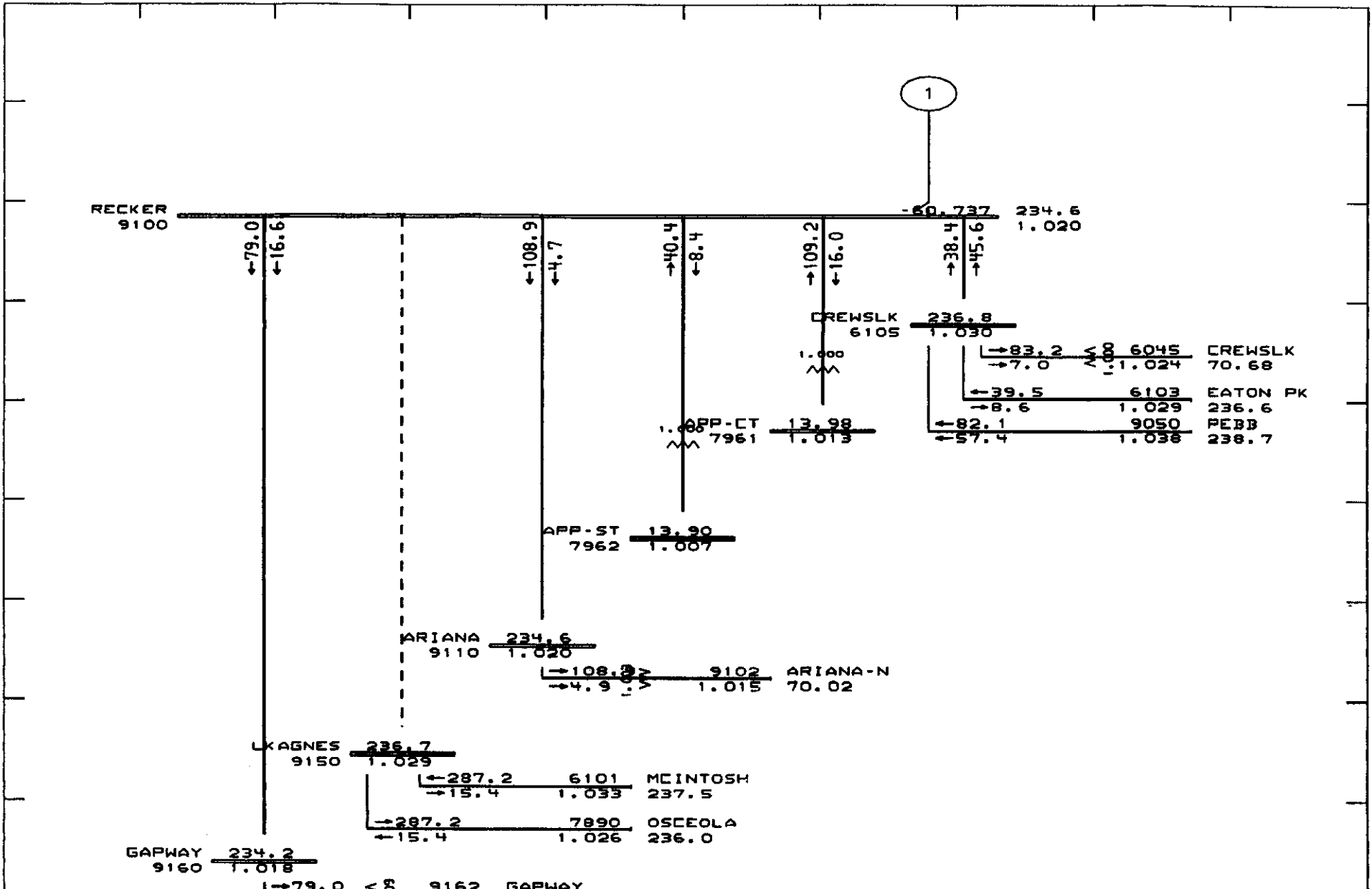

2004pl.sav
 P mis = -0.0019 MW
 Q mis = -0.0021 MVAR



RECKER
9100

←122.2
←30.2

←65.1
→26.9

→40.4
←8.3

→109.2
←15.9

1

-50.901 235.8
1.025

→37.8
→27.5

CREWSLK
6105

237.1
1.031

→88.5
→8.2

6045
1.025

CREWSLK
70.71

→55.1
→18.0

6103
1.029

EATON PK
236.8

→71.3
→49.5

9050
1.038

PEBB
238.8

1.006
APP-CT
7961

14.05
1.018

APP-ST
7962

13.97
1.012

ARIANA
9110

231.0
1.004

←0.0
←0.0

9102
1.001

ARIANA-N
69.10

LKAGNES
9150

236.3
1.027

←237.1
←4.8

6101
1.032

MCINTOSH
237.5

→302.1
←19.2

7890
1.025

OSCEOLA
235.9

GAPWAY
9160

235.1
1.022

→122.1
→30.6

9162
1.018

GAPWAY
70.21

2004pl.sav

P mis = -0.0019 MW

Q mis = -0.0021 MVAR



RECKER
9100

←64.7
←16.7

→12.6
→45.5

←97.5
←4.4

→40.4
←8.4

→109.2
←16.0

1

←51.963 234.9
1.019

CREWSLK
6105 237.7
1.033

→87.2 6045 CREWSLK
→9.7 70.78
1.026

←21.7 6103 EATON PK
→26.3 237.0
1.030

←65.5 9050 FE8B
←36.0 238.9
1.039

1.006 APP-CT 13.96
7961 1.011

APP-ST 13.88
7962 1.008

ARIANA 234.2
9110 1.018

→97.4 9102 ARIANA-N
→4.7 69.92
1.013

LKAGNES 235.6
9150 1.024

←236.8 6101 MCINTOSH
←16.0 237.4
1.032

→284.2 7890 OSCEOLA
←26.3 235.7
1.025

GAPWAY 233.9
9160 1.017

→64.6 9162 GAPWAY
→17.8 70.22
1.018

2004pl.sav
P mis = -0.0019 MW
Q mis = -0.0021 MVAR



PLF Program
FERC 2004 SUMMER BASE CASE - FY1998 - REVISION 5
PROPOSED OSPREY ENERGY CENTER

PLF/MWR Mod Feb 16 15:00:55 2000

2004pl.sav
Rating = 1

RECKER
9100

←305.4
→24.3

←183.8
→22.0

→40.4
←8.3

→109.2
←15.8

←530.0
→12.6

←190.3
→34.3

236.5
1.028

CREWSLK
6105

237.2
1.031

←98.3
→9.8

←1.000
→1.1.024

6045 CREWSLK
70.68

←39.1
→18.3

←1.029
→1.029

6103 EATON PK
236.8

←130.3
→64.9

←1.038
→1.038

9050 PEBB
238.7

←1.000
→14.09
←1.021

APP-CT
7961

←14.01
→1.015

APP-ST
7962

←236.3
→1.028

ARIANA
9110

←183.8
→21.8

9102 ARIANA-N
70.07

←236.4
→1.028

LKAGNES
9150

←120.3
→18.6

6101 MCINTOSH
237.5

←424.6
→13.3

7890 OSCEOLA
235.5

←229.8
→0.999

GAPWAY
9160

←0.0
→0.0

9162 GAPWAY
69.56

2004pia.sav
P mis = -0.0019 MW
Q mis = 0.0009 MVAR



RECKER
9100

←148.7
←21.5

←167.7
←11.1

→40.4
←8.3

→109.2
←15.8

←530.0
←15.5

236.5
1.028

CREWSLK
6105

237.1
1.031

→98.9
→9.8

←1.000
←1.024

6045 CREWSLK
70.64

→80.6
→11.1

←1.030
←1.038

6103 EATON PK
236.8

→180.9
→172.8

←1.038

9050 FEBB
238.7

APP-CT
7961

14.09
1.021

APP-ST
7962

14.01
1.015

ARIANA
9110

236.4
1.028

→167.8
→11.1

9102 ARIANA-N
70.45

LKAGNES
9150

236.4
1.028

←362.1
→17.4

6101 MCINTOSH
237.4

→362.1
←17.4

7890 OSCEOLA
235.7

GAPWAY
9160

235.9
1.026

→148.5
→21.5

←1.026

9162 GAPWAY
70.77

2004pia.sav
P mis = -0.0019 MW
Q mis = 0.0009 MVAR



GENERAL ELECTRIC COMPANY
FERC 2004 SUMMER BASE CASE - FY1998 - REVISION 5
PROPOSED OSPREY ENERGY CENTER

HW/MVAR Mod Feb 16 15:01:29 2000

2004pia.sav
Rating = 1

RECKER
9100

←175.2

←35.5

←307.4

→24.1

→40.4

←8.3

→109.2

←15.8

1
←530.0
←1.0

←53.7

←74.5

←197.0

→34.4

236.6
1.028

CREWSLK
6105

1.000
^^

237.2
1.031

→100.6
→9.9

1.000
^^

6045
1.024

CREWSLK
70.67

→46.8
→18.6

6103
1.029

EATON PK
236.8

→142.3
→65.9

9050
1.038

PEBB
238.7

1.000
^^
APP-CT
7961

14.09
1.021

APP-ST
7962

14.01
1.015

ARIANA
9110

230.8
1.003

→0.0
→0.0

1.003
^^

9102
1.001

ARIANA-N
69.05

LKAGNES
9150

236.4
1.028

→121.9
→18.7

6101
1.033

MCINTOSH
237.5

→428.1
→13.2

7890
1.024

OSCEOLA
235.5

GAPWAY
9160

235.6
1.025

→174.9
→34.9

1.003
^^

9162
1.019

GAPWAY
70.32

2004pla.sav

P mis = -0.0019 MW

Q mis = 0.0009 MVAR



RECKER
9100

←132.4
←21.5

←389.3
→27.4

←157.8
←10.4

→40.4
←8.3

→109.2
←15.8

←530.0
←28.5

236.5
1.028

CREWSLK
6105

237.5
1.033

→81.8
→10.6

6045 CREWSLK
70.68

←136.4
→38.4

6103 EATON PK
236.9

→54.6
→49.1

9050 FEBB
238.8

APP-CT
7961

14.09
1.021

APP-ST
7962

14.01
1.015

ARIANA
9110

236.4
1.028

→157.8
→10.4

9102 ARIANA-N
70.45

LKAGNES
9150

236.4
1.028

→53.9
→29.2

6101 MCINTOSH
237.5

→441.4
←12.7

7890 OSCEOLA
235.4

GAPWAY
9160

235.9
1.026

→132.3
→21.7

9162 GAPWAY
70.75

2004pia.sav
P mis = -0.0019 MW
Q mis = 0.0009 MVAR



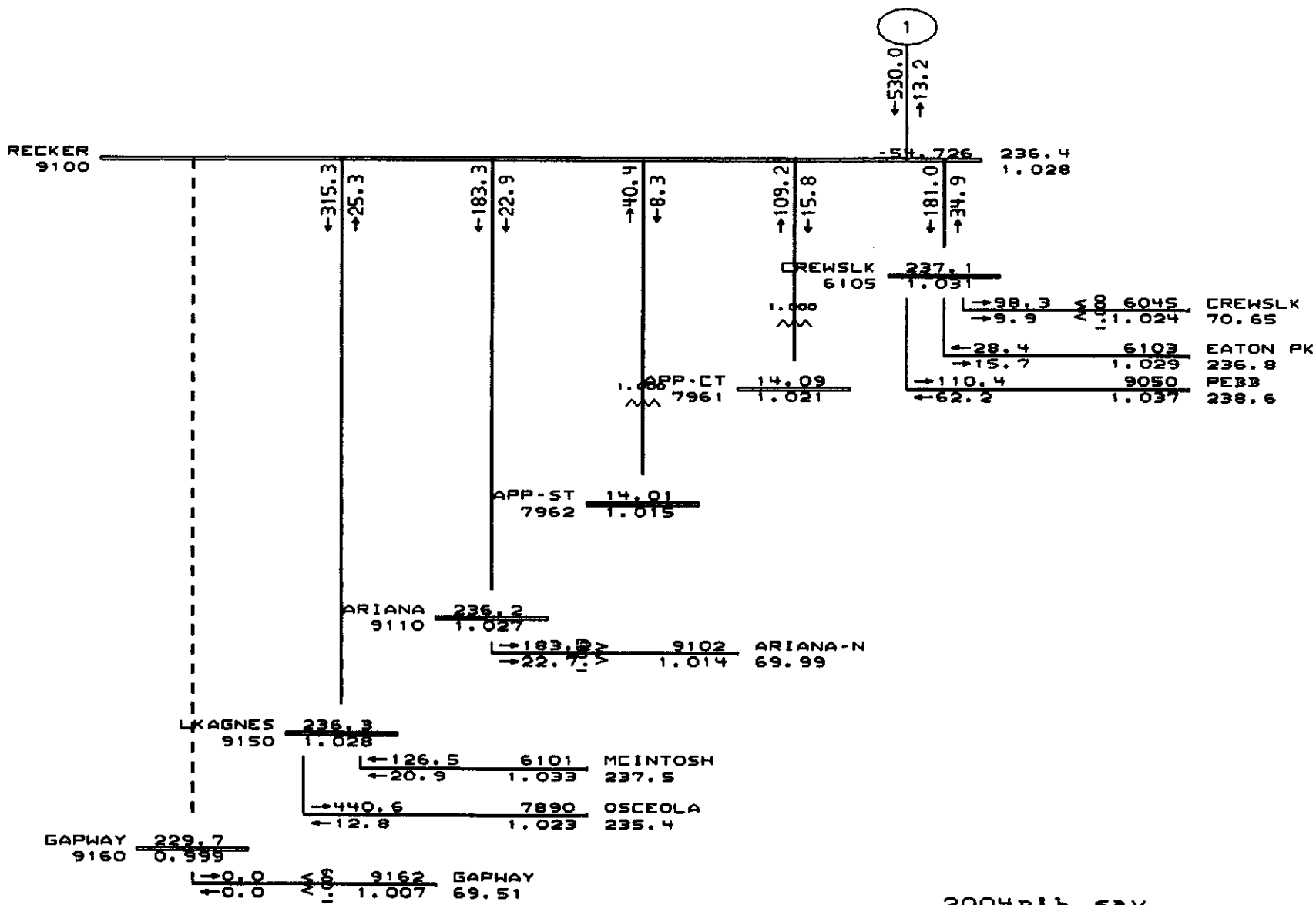

2004plb.sav
P mis = -0.0004 MW
Q mis = 0.0001 MVAR



RECKER
9100

←149.8

←21.8

←168.2

←12.0

→40.4

←8.3

→109.2

←15.8

530.0

←15.7

236.4
1.028

CREWSLK
6105

237.0
1.030

→99.0
→9.9

6045
1.023

CREWSLK
70.61

→96.8
→2.0

6103
1.030

EATON PK
236.8

→162.9
→70.6

9050
1.037

PEBB
238.6

APP-CT
7961

14.09
1.021

APP-ST
7962

14.01
1.015

ARIANA
9110

236.3
1.027

→168.8
→12.0

9102
1.020

ARIANA-N
70.38

LKAGNES
9150

236.3
1.027

←376.7
→17.2

6101
1.032

MCINTOSH
237.4

→376.7
←17.2

7890
1.024

OSCEOLA
235.6

GAPWAY
9160

235.8
1.025

→149.5
→21.7

9162
1.025

GAPWAY
70.72

2004plb.sav

P mis = -0.0004 MW

Q mis = 0.0001 MVAR



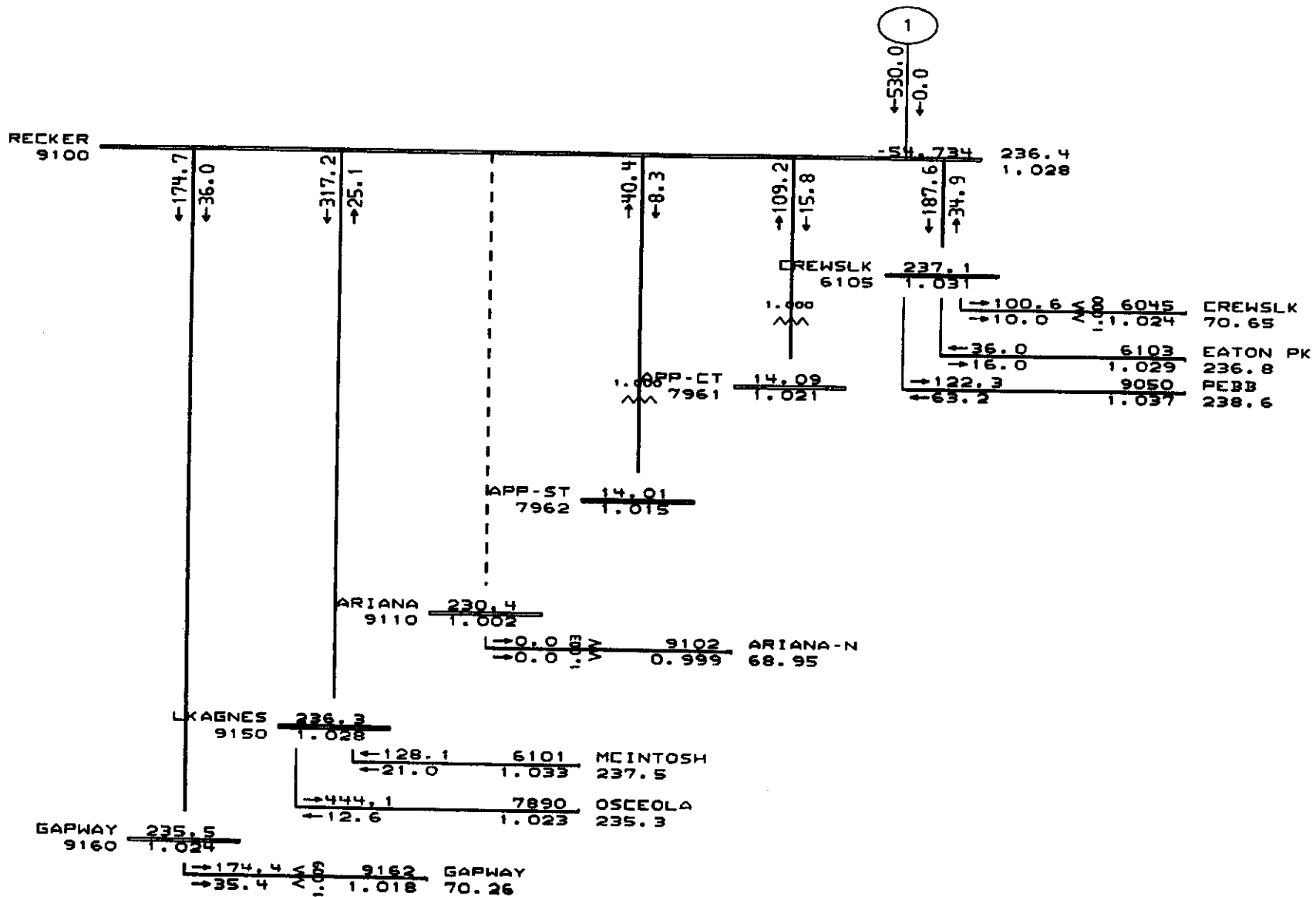

2004plb.sav
 P mis = -0.0004 MW
 Q mis = 0.0001 MVAR



RECKER
9100

←130.9
←21.7

←392.4
→28.0

←156.3
←11.2

→40.4
←8.3

→109.2
←15.8

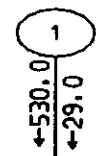

←530.0
←29.0

←58.611 236.4
1.028

CREWSLK
6105

237.5
1.035

→82.4
→10.7

←1.000
←1.024

6045 CREWSLK
70.66

←120.7
→35.3

←1.030
←1.038

6103 EATON PK
236.9

→38.3
→46.0

←1.030
←1.038

9050 PEBB
238.7

APP-CT
7961

14.09
1.021

APP-ST
7962

14.01
1.015

ARIANA
9110

236.3
1.027

→156.8
→11.2

9102 ARIANA-N
70.38

LXAGNES
9150

236.3
1.027

←65.5
←30.8

6101 MCINTOSH
237.5

→456.0
←12.1

7890 OSCEOLA
235.3

GAPWAY
9160

235.8
1.025

→130.8
→22.0

←1.000
←1.025

9162 GAPWAY
70.71

2004plb.sav
P mis = -0.0004 MW
Q mis = 0.0001 MVAR

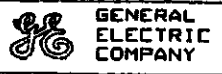

RECKER
9100

←286.9
→26.8

←184.5
→21.3

→40.4
←8.3

→109.2
←15.8

1
←530.0
→13.0

236.5
1.028

←208.2
→31.6

CREWSLK
6105

237.0
1.030

→100.0
→10.4

6045
1.023

CREWSLK
70.59

→51.2
→15.8

6103
1.029

EATON PK
236.7

→159.5
→61.5

9050
1.036

PEBB
238.3

1.005
APP-CT
7961

14.09
1.021

APP-ST
7962

14.01
1.015

ARIANA
9110

236.4
1.028

→184.8
→21.1

9102
1.016

ARIANA-N
70.10

LKAGNES
9150

236.5
1.028

←98.1
←18.8

6101
1.033

MCINTOSH
237.5

→383.9
→14.4

7890
1.025

OSCEOLA
235.6

GAPWAY
9160

229.9
1.000

←0.0
→0.0

1.005
9162
1.008

GAPWAY
69.58

2004pic.sav

P mis = 0.0007 MW

Q mis = 0.0019 MVAR

General Electric Company PS&T Program



FERC 2004 SUMMER BASE CASE - FY1998 - REVISION 5
PROPOSED OSPREY ENERGY CENTER

MW/MVAR

Wed Feb 16 15:03:27 2000

2004pic.sav
Rating = 1

RECKER
9100

←147.0
←21.1

←166.2
←10.4

→40.4
←8.3

→109.2
←15.8

←530.0
←18.0

236.5
1.028

CREWSLK
6105

←366.4
→37.5

→100.0
→10.4

6045 CREWSLK
70.55

→59.6
→0.5

6103 EATON PK
236.7

→203.9
→68.5

9050 PEBB
238.3

APP-CT
7961

→14.09
1.021

APP-ST
7962

→14.01
1.015

ARIANA
9110

←236.4
1.028

→166.8
→10.4

9102 ARIANA-N
70.48

LKAGNES
9150

←236.6
1.028

←325.9
→16.5

6101 MCINTOSH
237.5

←325.9
→16.5

7890 OSCEOLA
235.9

GAPWAY
9160

←235.9
1.026

→146.8
→21.1

9162 GAPWAY
70.78

2004pic.sav

P mis = 0.0007 MW

Q mis = 0.0019 MVAR

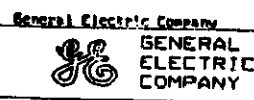

PSLF Program

FERC 2004 SUMMER BASE CASE - FY1998 - REVISION 5
PROPOSED OSPREY ENERGY CENTER

PM/MAR

Wed Feb 16 15:03:42 2000

2004pic.sav
Rating = 1

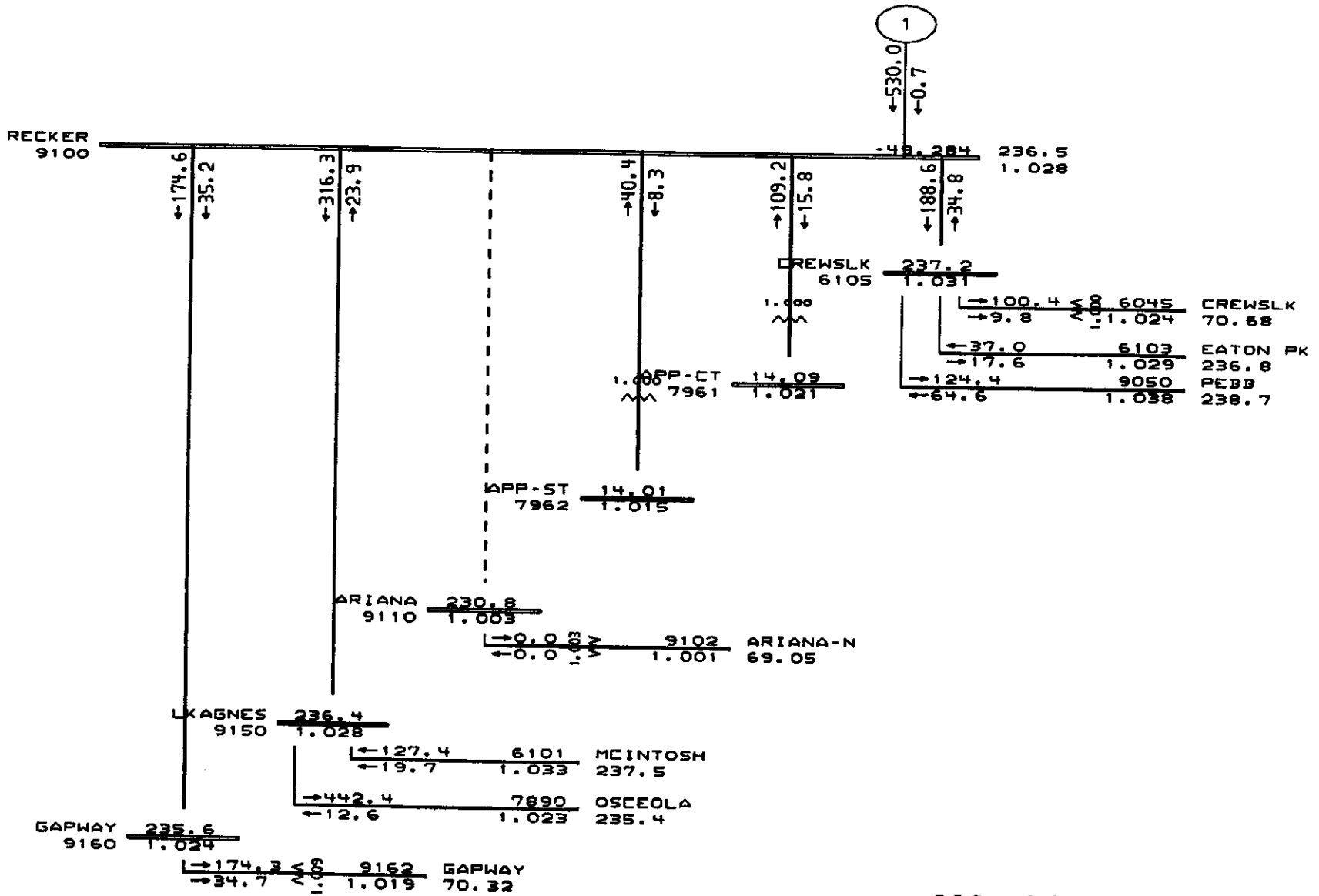

2004pld.sav
P mis = -0.0008 MW
Q mis = -0.0037 MVAR



RECKER
9100

←135.7

←21.1

←383.8

→30.6

←160.1

←9.8

→40.4

←8.3

→109.2

←15.8

1

←530.0
←24.4

→55.002

236.5
1.028

CREWSLK
6105

237.3
1.032

1.000
ΛΛ

→82.2
→11.1

6045
1.023

CREWSLK
70.58

←158.1
→36.0

6103
1.029

EATON PK
236.7

←75.9
←47.1

9050
1.037

PEBB
238.4

1.000
ΛΛ

APP-CT
7961

14.09
1.021

APP-ST
7962

14.01
1.015

ARIANA
9110

235.4
1.028

→160.8
→9.9

1.000
ΛΛ

9102
1.021

ARIANA-N
70.48

LXAGNES
9150

236.5
1.028

←21.2
←30.7

6101
1.033

MCINTOSH
237.5

→403.2
←13.9

7890
1.024

OSCEOLA
235.6

GAPWAY
9160

235.9
1.026

→135.5
→21.3

1.000
ΛΛ

9162
1.026

GAPWAY
70.77

2004pic.sav
P mis = 0.0007 MW
Q mis = 0.0019 MVAR



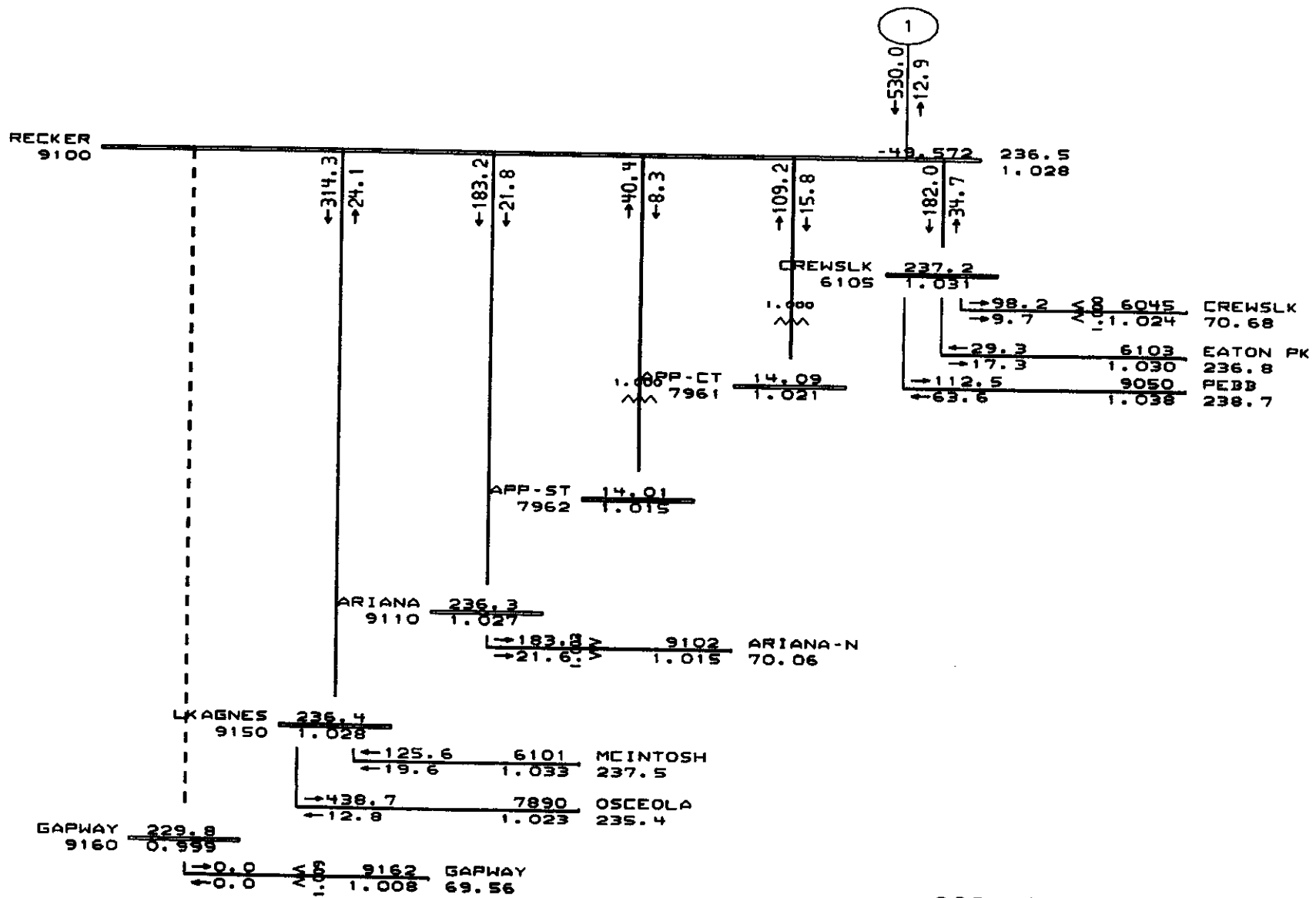

2004pld.sav
 P mis = -0.0008 MW
 Q mis = -0.0037 MVAR



RECKER
9100

←149.6

←21.3

←168.1

←11.0

→40.4

→8.3

→109.2

→15.8

530.0
-14.5

236.8
1.028

←361.9

→41.9

CREWSLK
6105

237.1
1.031

1.000

→98.9

→9.7

1.000

6045

1.024

CREWSLK
70.64

→94.8

→10.3

1.030

6103

1.030

EATON PK
236.8

→165.3

→71.9

1.038

9050

1.038

PEBB
238.7

APP-CT
7961

14.09
1.021

APP-ST
7962

14.01
1.015

ARIANA
9110

236.4
1.028

→168.8

→11.0

9102

1.021

ARIANA-N
70.44

LKAGNES
9150

236.3
1.027

→374.5

→17.5

6101

1.032

MCINTOSH
237.4

→374.5

→17.5

7890

1.024

OSCEOLA
235.6

GAPWAY
9160

235.9
1.025

→149.4

→21.3

9162

1.026

GAPWAY

70.76

2004pid.sav

P mis = -0.0008 MW

Q mis = -0.0037 MVAR

General Electric Company PSV Program



GENERAL
ELECTRIC
COMPANY

FERC 2004 SUMMER BASE CASE - FY1998 - REVISION 5
PROPOSED OSPREY ENERGY CENTER

MM/MVAR

Wed Feb 16 15:01:55 2000

2004pid.sav
Rating = 1

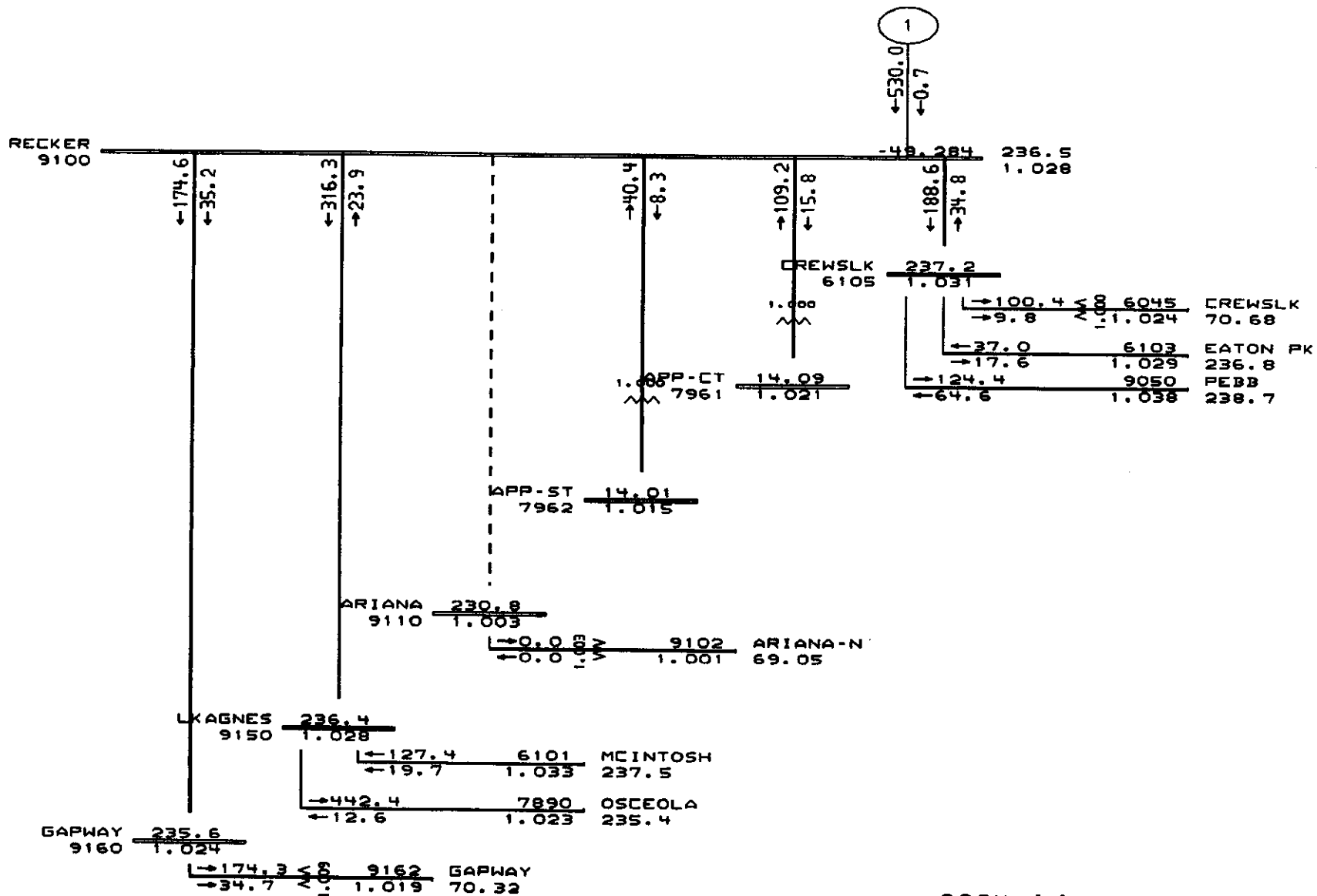

2004pid.sav
 P mis = -0.0008 MW
 Q mis = -0.0037 MVAR



RECKER
9100

←131.0

←21.3

←392.2

→26.8

←156.3

←10.2

→40.4

←8.3

→109.2

→15.8

←530.0
←28.7

←48.477

236.5
1.028

CREWSLK
6105

237.6
1.033

→82.2
→10.6

→1.000
→1.024

6045 CREWSLK
70.69

←122.2
→36.9

→1.030
→1.038

6103 EATON PK
236.9

→40.0
→47.5

→1.038

9050 PEBB
238.8

APP-CT
7961

14.09
1.021

APP-ST
7962

14.01
1.015

ARIANA
9110

236.4
1.028

→156.9
→10.2

→1.021

9102 ARIANA-N
70.45

LXAGNES
9150

236.3
1.028

→64.0
→29.5

→1.033

6101 MCINTOSH
237.5

→454.3
→12.1

→1.023

7890 OSCEOLA
235.3

GAPWAY
9160

235.9
1.026

→130.9
→21.6

→1.025

9162 GAPWAY
70.75

2004pid.sav

P mis = -0.0008 MW

Q mis = -0.0037 MVAR



RECKER
9100

←314.0
→24.1

←183.1
→21.7

→40.4
←8.3

→109.2
←15.8

←530.0
→12.9

236.5
1.028

←182.4
→34.5

CREWSLK
6105

237.2
1.031

←98.2
→9.7

←100
→1.024

6045 CREWSLK
70.68

←28.1
→17.2

←1.030
→1.038

6103 EATON PK
236.8

←111.6
→63.4

←1.038
→1.038

9050 PEBB
238.7

APP-CT
7961

14.09
1.021

APP-ST
7962

14.01
1.015

ARIANA
9110

236.3
1.028

←183.8
→21.6

9102 ARIANA-N
70.07

LKAGNES
9150

236.4
1.028

←123.3
→19.5

6101 MCINTOSH
237.5

→436.1
→12.9

7890 OSCEOLA
235.4

GAPWAY
9160

229.8
0.999

→0.0
→0.0

9162 GAPWAY
69.56

2004pic.sav
P mis = 0.0005 MW
Q mis = -0.0027 MVAR

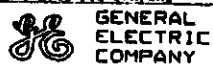

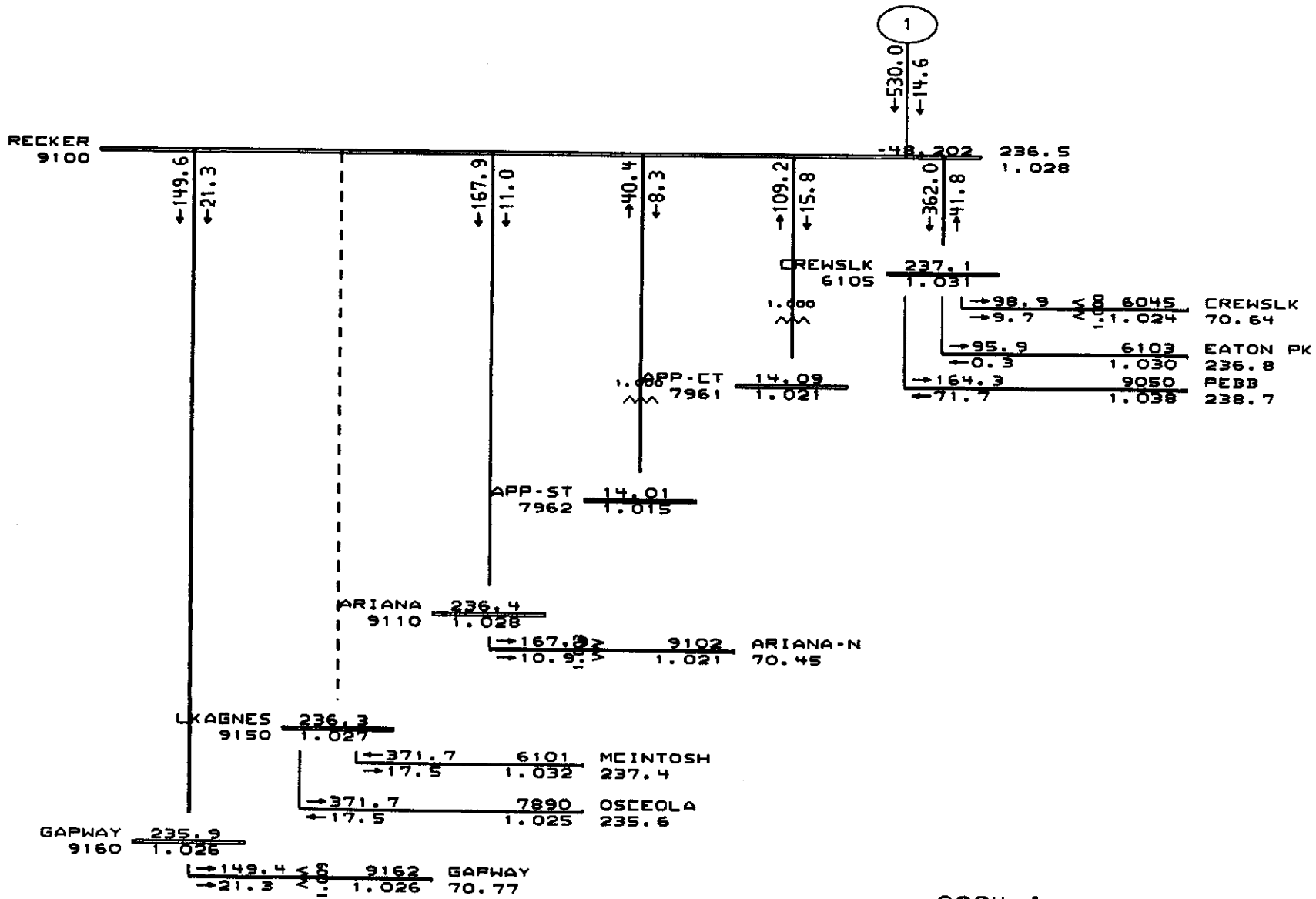

2004pie.sav
P mis = 0.0005 MW
Q mis = -0.0027 MVAR



RECKER
9100

←174.7

←35.2

←315.9

→23.9

→40.4

←8.3

→109.2

←15.8



←530.0

←0.7

→189.0

→34.6

236.5
1.028

CREWSLK
6105

237.2
1.031

→100.5
→9.8

6045
1.024

CREWSLK
70.68

←35.7
←17.6

6103
1.030

EATON PK
236.8

←123.5
←64.4

9050
1.038

PEBB
238.7

APP-CT
7961

14.09
1.021

APP-ST
7962

14.01
1.015

ARIANA
9110

230.8
1.004

→0.0
→0.0

9102
1.001

ARIANA-N
69.06

LKAGNES
9150

236.4
1.028

←124.9
←19.6

6101
1.033

MCINTOSH
237.5

→439.6
←12.7

7890
1.023

OSCEOLA
235.4

GAPWAY
9160

235.6
1.024

→174.4
→34.6

9162
1.019

GAPWAY
70.32

2004pic.sav

P mis = 0.0005 MW

Q mis = -0.0027 MVAR

General Electric Company

PLF Program



GENERAL
ELECTRIC
COMPANY

FERC 2004 SUMMER BASE CASE - FY1998 - REVISION 5
PROPOSED OSPREY ENERGY CENTER

MM/25MAR

Wed Feb 16 15:06:11 2000

2004pic.sav
Rating = 1

RECKER
9100

←131.1

←21.3

←392.1

→26.9

←156.3

←10.1

→40.4

←8.3

→109.2

←15.8

1

←530.0

←28.6

←49.803

236.5
1.028

CREWSLK
6105

237.6
1.033

1.000

→82.2

→10.6

←1.024

6045

CREWSLK
70.69

←121.1

→36.8

1.030

6103
EATON PK
236.9

→38.9

←47.4

1.038

9050
PEBB
238.8

1.005
APP-CT
7961

14.09
1.021

APP-ST
7962

14.01
1.015

ARIANA
9110

236.4
1.028

→156.2

→10.2

1.021

9102
ARIANA-N
70.45

LKAGNES
9150

236.3
1.028

→61.5

→29.5

1.033

6101
MCINTOSH
237.5

→451.7

→12.2

1.023

7890
OSCEOLA
235.3

GAPWAY
9160

235.9
1.026

→131.0

→21.6

1.025

9162
GAPWAY
70.75

2004pic.sav

P mis = 0.0005 MW

Q mis = -0.0027 MVAR

General Electric Company

PSLT Program



GENERAL
ELECTRIC
COMPANY

FERC 2004 SUMMER BASE CASE - FY1998 - REVISION 5
PROPOSED OSPREY ENERGY CENTER

MW/MVAR

Wed Feb 16 15:06:26 2000

2004pic.sav
Rating = 1

APPENDIX II

Table I
Comparison of Line & Transformer Flows
Following N-1 Disturbances
for Various OEC 500 MW Generation Alternatives

100% Load Base Case

All Flows above 100% of Emergency rating are Shown

Monitored Branches							Case 2004 Base No OEC Gen	Case 2004A Sell to FPL	Case 2004B Sell to FPC	Case 2004C Sell to TEC	Case 2004D Sell to JEA	Case 2004E Sell to SEM
Case	Bus 1	kV 1	Bus 2	kV 2	ckt	Area	Percent	Percent	Percent	Percent	Percent	Percent
2004-1	SN PLANT	230	SYLVAN	230	1	1						
2004-1	SYLVAN	230	N LONGWD	230	1	1						
2004-1	IND RIV	230	STANTON	230	1	11						
2004-1	SN PLANT	115	TURNER	115	1	1						
2004-1	BUCKEYE	230	RUSKMTR8	230	1	1						
2004-1	SILVR SP	230	SILV SPN	230	1	2						
2004-1	SILVR SP	230	OCALA 1	230	1	2						
2004-1	RIO PINR	230	CURRY FD	230	1	2						
2004-1	STANTON	230	CURRY FD	230	1	2						
2004-1	OSCEOLA	230	LKAGNES	230	1	16						
2004-1	SHELD	230	LK TARP	230	1	2						
2004-1	PEBB	230	CREWSLK	230	1	13						
2004-1	PEBB	230	N BARTOW	230	1	2						
2004-1	RECKER	230	LKAGNES	230	1	16						
2004-1	RECKER	230	ARIANA	230	1	16						
2004-1	RECKER	230	CREWSLK	230	1	13						
2004-1	B BEND	230	MANATEE	230	1	1						
2004-1	RUSKIN T	230	MANATEE	230	1	1						
2004-1	IND RIV	230	IND RIV	115	1	11						
2004-1	SHELD	230	SHELD-NW	69	1	16						
2004-1	LARGO	230	LARGO A	69	1	2						
2004-1	CLMT EST	230	CLMT EST	69	1	2						
2004-1	11TH AVE	230	ELEVEN-E	69	1	16						
2004-1	WINDERME	230	WINDERME	69	1	2						
2004-1	PASADENA	230	PASADENA	115	1	2						
2004-1	ARIANA	230	ARIANA-N	69	1	16						
2004-1	SELOSE	230	SELOSE-N	69	1	16						
2004-1	GAPWAY	230	GAPWAY	69	1	16						
2004-1	CREWSLK	230	CREWSLK	69	1	13						
2004-1	TENOROC	230	TENOROC	69	1	13						
2004-1	BARCOLA	230	WEST	230	1	2						
2004-1	EATON PK	230	CREWSLK	230	1	13						
2004-1	EATON PK	230	EATON PK	69	1	13						
2004-1	EATON PK	230	TENOROC	230	1	13						
2004-1	RECKER	230	GAPWAY	230	1	16						
2004-1	SN PLANT	115	TURNER	115	1	1						
2004-2	SN PLANT	230	SYLVAN	230	1	1						
2004-2	SYLVAN	230	N LONGWD	230	1	1						
2004-2	IND RIV	230	STANTON	230	1	11						
2004-2	SN PLANT	115	TURNER	115	1	1						
2004-2	BUCKEYE	230	RUSKMTR8	230	1	1						
2004-2	SILVR SP	230	SILV SPN	230	1	2						
2004-2	SILVR SP	230	OCALA 1	230	1	2						
2004-2	RIO PINR	230	CURRY FD	230	1	2						
2004-2	STANTON	230	CURRY FD	230	1	2						
2004-2	OSCEOLA	230	LKAGNES	230	1	16						
2004-2	SHELD	230	LK TARP	230	1	2						
2004-2	PEBB	230	CREWSLK	230	1	13						
2004-2	PEBB	230	N BARTOW	230	1	2						
2004-2	RECKER	230	LKAGNES	230	1	16						
2004-2	RECKER	230	ARIANA	230	1	16						
2004-2	RECKER	230	CREWSLK	230	1	13						
2004-2	B BEND	230	MANATEE	230	1	1						
2004-2	RUSKIN T	230	MANATEE	230	1	1						
2004-2	IND RIV	230	IND RIV	115	1	11						
2004-2	SHELD	230	SHELD-NW	69	1	16						
2004-2	LARGO	230	LARGO A	69	1	2						
2004-2	CLMT EST	230	CLMT EST	69	1	2						
2004-2	11TH AVE	230	ELEVEN-E	69	1	16						
2004-2	WINDERME	230	WINDERME	69	1	2						
2004-2	PASADENA	230	PASADENA	115	1	2						
2004-2	ARIANA	230	ARIANA-N	69	1	16						
2004-2	SELOSE	230	SELOSE-N	69	1	16						
2004-2	GAPWAY	230	GAPWAY	69	1	16						
2004-2	CREWSLK	230	CREWSLK	69	1	13						
2004-2	TENOROC	230	TENOROC	69	1	13						
2004-2	BARCOLA	230	WEST	230	1	2						
2004-2	EATON PK	230	CREWSLK	230	1	13						
2004-2	EATON PK	230	EATON PK	69	1	13						
2004-2	EATON PK	230	TENOROC	230	1	13						
2004-2	RECKER	230	GAPWAY	230	1	16						
2004-2	SN PLANT	115	TURNER	115	1	1						

Table I
Comparison of Line & Transformer Flows
Following N-1 Disturbances
for Various OEC 500 MW Generation Alternatives

100% Load Base Case

All Flows above 100% of Emergency rating are Shown

Monitored Branches							Case 2004 Base No OEC Gen	Case 2004A Sell to FPL	Case 2004B Sell to FPC	Case 2004C Sell to TEC	Case 2004D Sell to JEA	Case 2004E Sell to SEM
Case	Bus 1	kV 1	Bus 2	kV 2	ckt	Area	Percent	Percent	Percent	Percent	Percent	Percent
2004-3	SN PLANT	230	SYLVAN	230	1	1						
2004-3	SYLVAN	230	N LONGWD	230	1	1						
2004-3	IND RIV	230	STANTON	230	1	11						
2004-3	SN PLANT	115	TURNER	115	1	1						
2004-3	BUCKEYE	230	RUSKMTR8	230	1	1						
2004-3	SILVR SP	230	SILV SPN	230	1	2						
2004-3	SILVR SP	230	OCALA 1	230	1	2						
2004-3	RIO PINR	230	CURRY FD	230	1	2						
2004-3	STANTON	230	CURRY FD	230	1	2						
2004-3	OSCEOLA	230	LKAGNES	230	1	16						
2004-3	SHELD	230	LK TARPEN	230	1	2						
2004-3	PEBB	230	CREWSLK	230	1	13						
2004-3	PEBB	230	N BARTOW	230	1	2						
2004-3	RECKER	230	LKAGNES	230	1	16						
2004-3	RECKER	230	ARIANA	230	1	16						
2004-3	RECKER	230	CREWSLK	230	1	13						
2004-3	B BEND	230	MANATEE	230	1	1						
2004-3	RUSKIN T	230	MANATEE	230	1	1						
2004-3	IND RIV	230	IND RIV	115	1	11						
2004-3	SHELD	230	SHELD-NW	69	1	16						
2004-3	LARGO	230	LARGO A	69	1	2						
2004-3	CLMT EST	230	CLMT EST	69	1	2						
2004-3	11TH AVE	230	ELEVEN-E	69	1	16						
2004-3	WINDERME	230	WINDERME	69	1	2						
2004-3	PASADENA	230	PASADENA	115	1	2						
2004-3	ARIANA	230	ARIANA-N	69	1	16						
2004-3	SELOSE	230	SELOSE-N	69	1	16						
2004-3	GAPWAY	230	GAPWAY	69	1	16						
2004-3	CREWSLK	230	CREWSLK	69	1	13						
2004-3	TENOROC	230	TENOROC	69	1	13						
2004-3	BARCOLA	230	WEST	230	1	2						
2004-3	EATON PK	230	CREWSLK	230	1	13						
2004-3	EATON PK	230	EATON PK	69	1	13						
2004-3	EATON PK	230	TENOROC	230	1	13						
2004-3	RECKER	230	GAPWAY	230	1	16						
2004-3	SN PLANT	115	TURNER	115	1	1						
2004-4	SN PLANT	230	SYLVAN	230	1	1						
2004-4	SYLVAN	230	N LONGWD	230	1	1						
2004-4	IND RIV	230	STANTON	230	1	11						
2004-4	SN PLANT	115	TURNER	115	1	1						
2004-4	BUCKEYE	230	RUSKMTR8	230	1	1						
2004-4	SILVR SP	230	SILV SPN	230	1	2						
2004-4	SILVR SP	230	OCALA 1	230	1	2						
2004-4	RIO PINR	230	CURRY FD	230	1	2						
2004-4	STANTON	230	CURRY FD	230	1	2						
2004-4	OSCEOLA	230	LKAGNES	230	1	16						
2004-4	SHELD	230	LK TARPEN	230	1	2						
2004-4	PEBB	230	CREWSLK	230	1	13						
2004-4	PEBB	230	N BARTOW	230	1	2						
2004-4	RECKER	230	LKAGNES	230	1	16						
2004-4	RECKER	230	ARIANA	230	1	16						
2004-4	RECKER	230	CREWSLK	230	1	13						
2004-4	B BEND	230	MANATEE	230	1	1						
2004-4	RUSKIN T	230	MANATEE	230	1	1						
2004-4	IND RIV	230	IND RIV	115	1	11						
2004-4	SHELD	230	SHELD-NW	69	1	16						
2004-4	LARGO	230	LARGO A	69	1	2						
2004-4	CLMT EST	230	CLMT EST	69	1	2						
2004-4	11TH AVE	230	ELEVEN-E	69	1	16						
2004-4	WINDERME	230	WINDERME	69	1	2						
2004-4	PASADENA	230	PASADENA	115	1	2						
2004-4	ARIANA	230	ARIANA-N	69	1	16						
2004-4	SELOSE	230	SELOSE-N	69	1	16						
2004-4	GAPWAY	230	GAPWAY	69	1	16						
2004-4	CREWSLK	230	CREWSLK	69	1	13						
2004-4	TENOROC	230	TENOROC	69	1	13						
2004-4	BARCOLA	230	WEST	230	1	2						
2004-4	EATON PK	230	CREWSLK	230	1	13						
2004-4	EATON PK	230	EATON PK	69	1	13						
2004-4	EATON PK	230	TENOROC	230	1	13						
2004-4	RECKER	230	GAPWAY	230	1	16						
2004-4	SN PLANT	115	TURNER	115	1	1						

Table I
Comparison of Line & Transformer Flows
Following N-1 Disturbances
for Various OEC 500 MW Generation Alternatives

100% Load Base Case

All Flows above 100% of Emergency rating are Shown

Monitored Branches							Case 2004 Base No OEC Gen	Case 2004A Sell to FPL	Case 2004B Sell to FPC	Case 2004C Sell to TEC	Case 2004D Sell to JEA	Case 2004E Sell to SEM
Case	Bus 1	kV 1	Bus 2	kV 2	ckt	Area	Percent	Percent	Percent	Percent	Percent	Percent
2004-5	SN PLANT	230	SYLVAN	230	1	1						
2004-5	SYLVAN	230	N LONGWD	230	1	1						
2004-5	IND RIV	230	STANTON	230	1	11						
2004-5	SN PLANT	115	TURNER	115	1	1						
2004-5	BUCKEYE	230	RUSKMTR8	230	1	1						
2004-5	SILVR SP	230	SILV SPN	230	1	2						
2004-5	SILVR SP	230	OCALA 1	230	1	2						
2004-5	RIO PINR	230	CURRY FD	230	1	2						
2004-5	STANTON	230	CURRY FD	230	1	2						
2004-5	OSCEOLA	230	LKAGNES	230	1	16						
2004-5	SHELD	230	LK TARP	230	1	2						
2004-5	PEBB	230	CREWSLK	230	1	13						
2004-5	PEBB	230	N BARTOW	230	1	2						
2004-5	RECKER	230	LKAGNES	230	1	16						
2004-5	RECKER	230	ARIANA	230	1	16						
2004-5	RECKER	230	CREWSLK	230	1	13						
2004-5	B BEND	230	MANATEE	230	1	1						
2004-5	RUSKIN T	230	MANATEE	230	1	1						
2004-5	IND RIV	230	IND RIV	115	1	11						
2004-5	SHELD	230	SHELD-NW	69	1	16						
2004-5	LARGO	230	LARGO A	69	1	2						
2004-5	CLMT EST	230	CLMT EST	69	1	2						
2004-5	11TH AVE	230	ELEVEN-E	69	1	16						
2004-5	WINDERME	230	WINDERME	69	1	2						
2004-5	PASADENA	230	PASADENA	115	1	2						
2004-5	ARIANA	230	ARIANA-N	69	1	16						
2004-5	SELOSE	230	SELOSE-N	69	1	16						
2004-5	GAPWAY	230	GAPWAY	69	1	16						
2004-5	CREWSLK	230	CREWSLK	69	1	13						
2004-5	TENOROC	230	TENOROC	69	1	13						
2004-5	BARCOLA	230	WEST	230	1	2						
2004-5	EATON PK	230	CREWSLK	230	1	13						
2004-5	EATON PK	230	EATON PK	69	1	13						
2004-5	EATON PK	230	TENOROC	230	1	13						
2004-5	RECKER	230	GAPWAY	230	1	16						
2004-5	SN PLANT	115	TURNER	115	1	1						
2004-6	SN PLANT	230	SYLVAN	230	1	1						
2004-6	SYLVAN	230	N LONGWD	230	1	1						
2004-6	IND RIV	230	STANTON	230	1	11						
2004-6	SN PLANT	115	TURNER	115	1	1						
2004-6	BUCKEYE	230	RUSKMTR8	230	1	1						
2004-6	SILVR SP	230	SILV SPN	230	1	2						
2004-6	SILVR SP	230	OCALA 1	230	1	2						
2004-6	RIO PINR	230	CURRY FD	230	1	2						
2004-6	STANTON	230	CURRY FD	230	1	2						
2004-6	OSCEOLA	230	LKAGNES	230	1	16			100.8		100.2	100.1
2004-6	SHELD	230	LK TARP	230	1	2						
2004-6	PEBB	230	CREWSLK	230	1	13						
2004-6	PEBB	230	N BARTOW	230	1	2						
2004-6	RECKER	230	LKAGNES	230	1	16						
2004-6	RECKER	230	ARIANA	230	1	16						
2004-6	RECKER	230	CREWSLK	230	1	13						
2004-6	B BEND	230	MANATEE	230	1	1						
2004-6	RUSKIN T	230	MANATEE	230	1	1						
2004-6	IND RIV	230	IND RIV	115	1	11						
2004-6	SHELD	230	SHELD-NW	69	1	16						
2004-6	LARGO	230	LARGO A	69	1	2						
2004-6	CLMT EST	230	CLMT EST	69	1	2						
2004-6	11TH AVE	230	ELEVEN-E	69	1	16						
2004-6	WINDERME	230	WINDERME	69	1	2						
2004-6	PASADENA	230	PASADENA	115	1	2						
2004-6	ARIANA	230	ARIANA-N	69	1	16						
2004-6	SELOSE	230	SELOSE-N	69	1	16						
2004-6	GAPWAY	230	GAPWAY	69	1	16						
2004-6	CREWSLK	230	CREWSLK	69	1	13						
2004-6	TENOROC	230	TENOROC	69	1	13						
2004-6	BARCOLA	230	WEST	230	1	2						
2004-6	EATON PK	230	CREWSLK	230	1	13						
2004-6	EATON PK	230	EATON PK	69	1	13						
2004-6	EATON PK	230	TENOROC	230	1	13						
2004-6	RECKER	230	GAPWAY	230	1	16						
2004-6	SN PLANT	115	TURNER	115	1	1						

Table I
Comparison of Line & Transformer Flows
Following N-1 Disturbances
for Various OEC 500 MW Generation Alternatives

100% Load Base Case

All Flows above 100% of Emergency rating are Shown

Monitored Branches							Case 2004 Base No OEC Gen	Case 2004A Sell to FPL	Case 2004B Sell to FPC	Case 2004C Sell to TEC	Case 2004D Sell to JEA	Case 2004E Sell to SEM
Case#	Bus 1	kV 1	Bus 2	kV 2	ckt	Area	Percent	Percent	Percent	Percent	Percent	Percent
2004-7	SN PLANT	230	SYLVAN	230	1	1						
2004-7	SYLVAN	230	N LONGWD	230	1	1						
2004-7	IND RIV	230	STANTON	230	1	11						
2004-7	SN PLANT	115	TURNER	115	1	1						
2004-7	BUCKEYE	230	RUSKMTR8	230	1	1						
2004-7	SILVR SP	230	SILV SPN	230	1	2						
2004-7	SILVR SP	230	OCALA 1	230	1	2						
2004-7	RIO PINR	230	CURRY FD	230	1	2						
2004-7	STANTON	230	CURRY FD	230	1	2						
2004-7	OSCEOLA	230	LKAGNES	230	1	16						
2004-7	SHELD	230	LK TARPEN	230	1	2						
2004-7	PEBB	230	CREWSLK	230	1	13						
2004-7	PEBB	230	N BARTOW	230	1	2						
2004-7	RECKER	230	LKAGNES	230	1	16						
2004-7	RECKER	230	ARIANA	230	1	16						
2004-7	RECKER	230	CREWSLK	230	1	13						
2004-7	B BEND	230	MANATEE	230	1	1						
2004-7	RUSKIN T	230	MANATEE	230	1	1						
2004-7	IND RIV	230	IND RIV	115	1	11						
2004-7	SHELD	230	SHELD-NW	69	1	16						
2004-7	LARGO	230	LARGO A	69	1	2						
2004-7	CLMT EST	230	CLMT EST	69	1	2						
2004-7	11TH AVE	230	ELEVEN-E	69	1	16						
2004-7	WINDERME	230	WINDERME	69	1	2						
2004-7	PASADENA	230	PASADENA	115	1	2						
2004-7	ARIANA	230	ARIANA-N	69	1	16						
2004-7	SELOSE	230	SELOSE-N	69	1	16						
2004-7	GAPWAY	230	GAPWAY	69	1	16						
2004-7	CREWSLK	230	CREWSLK	69	1	13						
2004-7	TENOROC	230	TENOROC	69	1	13						
2004-7	BARCOLA	230	WEST	230	1	2						
2004-7	EATON PK	230	CREWSLK	230	1	13						
2004-7	EATON PK	230	EATON PK	69	1	13						
2004-7	EATON PK	230	TENOROC	230	1	13						
2004-7	RECKER	230	GAPWAY	230	1	16						
2004-7	SN PLANT	115	TURNER	115	1	1						
2004-8	SN PLANT	230	SYLVAN	230	1	1						
2004-8	SYLVAN	230	N LONGWD	230	1	1						
2004-8	IND RIV	230	STANTON	230	1	11						
2004-8	SN PLANT	115	TURNER	115	1	1						
2004-8	BUCKEYE	230	RUSKMTR8	230	1	1						
2004-8	SILVR SP	230	SILV SPN	230	1	2						
2004-8	SILVR SP	230	OCALA 1	230	1	2						
2004-8	RIO PINR	230	CURRY FD	230	1	2						
2004-8	STANTON	230	CURRY FD	230	1	2						
2004-8	OSCEOLA	230	LKAGNES	230	1	16						
2004-8	SHELD	230	LK TARPEN	230	1	2						
2004-8	PEBB	230	CREWSLK	230	1	13						
2004-8	PEBB	230	N BARTOW	230	1	2						
2004-8	RECKER	230	LKAGNES	230	1	16						
2004-8	RECKER	230	ARIANA	230	1	16						
2004-8	RECKER	230	CREWSLK	230	1	13						
2004-8	B BEND	230	MANATEE	230	1	1						
2004-8	RUSKIN T	230	MANATEE	230	1	1						
2004-8	IND RIV	230	IND RIV	115	1	11						
2004-8	SHELD	230	SHELD-NW	69	1	16						
2004-8	LARGO	230	LARGO A	69	1	2						
2004-8	CLMT EST	230	CLMT EST	69	1	2						
2004-8	11TH AVE	230	ELEVEN-E	69	1	16						
2004-8	WINDERME	230	WINDERME	69	1	2						
2004-8	PASADENA	230	PASADENA	115	1	2						
2004-8	ARIANA	230	ARIANA-N	69	1	16						
2004-8	SELOSE	230	SELOSE-N	69	1	16						
2004-8	GAPWAY	230	GAPWAY	69	1	16						
2004-8	CREWSLK	230	CREWSLK	69	1	13						
2004-8	TENOROC	230	TENOROC	69	1	13						
2004-8	BARCOLA	230	WEST	230	1	2						
2004-8	EATON PK	230	CREWSLK	230	1	13						
2004-8	EATON PK	230	EATON PK	69	1	13						
2004-8	EATON PK	230	TENOROC	230	1	13						
2004-8	RECKER	230	GAPWAY	230	1	16						
2004-8	SN PLANT	115	TURNER	115	1	1						

Table I
Comparison of Line & Transformer Flows
Following N-1 Disturbances
for Various OEC 500 MW Generation Alternatives

100% Load Base Case

All Flows above 100% of Emergency rating are Shown

Monitored Branches							Case 2004 Base No OEC Gen	Case 2004A Sell to FPL	Case 2004B Sell to FPC	Case 2004C Sell to TEC	Case 2004D Sell to JEA	Case 2004E Sell to SEM
Case	Bus 1	kV 1	Bus 2	kV 2	ckt	Area	Percent	Percent	Percent	Percent	Percent	Percent
2004-9	SN PLANT	230	SYLVAN	230	1	1						
2004-9	SYLVAN	230	N LONGWD	230	1	1						
2004-9	IND RIV	230	STANTON	230	1	11						
2004-9	SN PLANT	115	TURNER	115	1	1						
2004-9	BUCKEYE	230	RUSKMTR8	230	1	1						
2004-9	SILVR SP	230	SILV SPN	230	1	2						
2004-9	SILVR SP	230	OCALA 1	230	1	2						
2004-9	RIO PINR	230	CURRY FD	230	1	2						
2004-9	STANTON	230	CURRY FD	230	1	2						
2004-9	OSCEOLA	230	LKAGNES	230	1	16						
2004-9	SHELD	230	LK TARPEN	230	1	2						
2004-9	PEBB	230	CREWSLK	230	1	13						
2004-9	PEBB	230	N BARTOW	230	1	2						
2004-9	RECKER	230	LKAGNES	230	1	16						
2004-9	RECKER	230	ARIANA	230	1	16						
2004-9	RECKER	230	CREWSLK	230	1	13						
2004-9	B BEND	230	MANATEE	230	1	1						
2004-9	RUSKIN T	230	MANATEE	230	1	1						
2004-9	IND RIV	230	IND RIV	115	1	11						
2004-9	SHELD	230	SHELD-NW	69	1	16						
2004-9	LARGO	230	LARGO A	69	1	2						
2004-9	CLMT EST	230	CLMT EST	69	1	2						
2004-9	11TH AVE	230	ELEVEN-E	69	1	16						
2004-9	WINDERME	230	WINDERME	69	1	2						
2004-9	PASADENA	230	PASADENA	115	1	2						
2004-9	ARIANA	230	ARIANA-N	69	1	16						
2004-9	SELOSE	230	SELOSE-N	69	1	16						
2004-9	GAPWAY	230	GAPWAY	69	1	16						
2004-9	CREWSLK	230	CREWSLK	69	1	13						
2004-9	TENOROC	230	TENOROC	69	1	13						
2004-9	BARCOLA	230	WEST	230	1	2						
2004-9	EATON PK	230	CREWSLK	230	1	13						
2004-9	EATON PK	230	EATON PK	69	1	13						
2004-9	EATON PK	230	TENOROC	230	1	13						
2004-9	RECKER	230	GAPWAY	230	1	16						
2004-9	SN PLANT	115	TURNER	115	1	1						
2004-10	SN PLANT	230	SYLVAN	230	1	1						
2004-10	SYLVAN	230	N LONGWD	230	1	1						
2004-10	IND RIV	230	STANTON	230	1	11						
2004-10	SN PLANT	115	TURNER	115	1	1						
2004-10	BUCKEYE	230	RUSKMTR8	230	1	1						
2004-10	SILVR SP	230	SILV SPN	230	1	2						
2004-10	SILVR SP	230	OCALA 1	230	1	2						
2004-10	RIO PINR	230	CURRY FD	230	1	2						
2004-10	STANTON	230	CURRY FD	230	1	2						
2004-10	OSCEOLA	230	LKAGNES	230	1	16						
2004-10	SHELD	230	LK TARPEN	230	1	2						
2004-10	PEBB	230	CREWSLK	230	1	13						
2004-10	PEBB	230	N BARTOW	230	1	2						
2004-10	RECKER	230	LKAGNES	230	1	16						
2004-10	RECKER	230	ARIANA	230	1	16						
2004-10	RECKER	230	CREWSLK	230	1	13						
2004-10	B BEND	230	MANATEE	230	1	1						
2004-10	RUSKIN T	230	MANATEE	230	1	1						
2004-10	IND RIV	230	IND RIV	115	1	11						
2004-10	SHELD	230	SHELD-NW	69	1	16						
2004-10	LARGO	230	LARGO A	69	1	2						
2004-10	CLMT EST	230	CLMT EST	69	1	2						
2004-10	11TH AVE	230	ELEVEN-E	69	1	16						
2004-10	WINDERME	230	WINDERME	69	1	2						
2004-10	PASADENA	230	PASADENA	115	1	2						
2004-10	ARIANA	230	ARIANA-N	69	1	16						
2004-10	SELOSE	230	SELOSE-N	69	1	16						
2004-10	GAPWAY	230	GAPWAY	69	1	16						
2004-10	CREWSLK	230	CREWSLK	69	1	13						
2004-10	TENOROC	230	TENOROC	69	1	13						
2004-10	BARCOLA	230	WEST	230	1	2						
2004-10	EATON PK	230	CREWSLK	230	1	13						
2004-10	EATON PK	230	EATON PK	69	1	13						
2004-10	EATON PK	230	TENOROC	230	1	13						
2004-10	RECKER	230	GAPWAY	230	1	16						
2004-10	SN PLANT	115	TURNER	115	1	1						

Table I
Comparison of Line & Transformer Flows
Following N-1 Disturbances
for Various OEC 500 MW Generation Alternatives

100% Load Base Case

All Flows above 100% of Emergency rating are Shown

Monitored Branches							Case 2004	Case 2004A	Case 2004B	Case 2004C	Case 2004D	Case 2004E
Case	Bus 1	kV 1	Bus 2	kV 2	ckt	Area	Base No OEC Gen Percent	Sell to FPL Percent	Sell to FPC Percent	Sell to TEC Percent	Sell to JEA Percent	Sell to SEM Percent
2004-11	SN PLANT	230	SYLVAN	230	1	1						
2004-11	SYLVAN	230	N LONGWD	230	1	1						
2004-11	IND RIV	230	STANTON	230	1	11						
2004-11	SN PLANT	115	TURNER	115	1	1						
2004-11	BUCKEYE	230	RUSKMTR8	230	1	1						
2004-11	SILVR SP	230	SILV SPN	230	1	2						
2004-11	SILVR SP	230	OCALA 1	230	1	2						
2004-11	RIO PINR	230	CURRY FD	230	1	2						
2004-11	STANTON	230	CURRY FD	230	1	2						
2004-11	OSCEOLA	230	LKAGNES	230	1	16						
2004-11	SHELD	230	LK TARP	230	1	2						
2004-11	PEBB	230	CREWSLK	230	1	13						
2004-11	PEBB	230	N BARTOW	230	1	2						
2004-11	RECKER	230	LKAGNES	230	1	16						
2004-11	RECKER	230	ARIANA	230	1	16						
2004-11	RECKER	230	CREWSLK	230	1	13						
2004-11	B BEND	230	MANATEE	230	1	1						
2004-11	RUSKIN T	230	MANATEE	230	1	1						
2004-11	IND RIV	230	IND RIV	115	1	11						
2004-11	SHELD	230	SHELD-NW	69	1	16						
2004-11	LARGO	230	LARGO A	69	1	2						
2004-11	CLMT EST	230	CLMT EST	69	1	2						
2004-11	11TH AVE	230	ELEVEN-E	69	1	16						
2004-11	WINDERME	230	WINDERME	69	1	2						
2004-11	PASADENA	230	PASADENA	115	1	2						
2004-11	ARIANA	230	ARIANA-N	69	1	16						
2004-11	SELOSE	230	SELOSE-N	69	1	16						
2004-11	GAPWAY	230	GAPWAY	69	1	16						
2004-11	CREWSLK	230	CREWSLK	69	1	13						
2004-11	TENOROC	230	TENOROC	69	1	13						
2004-11	BARCOLA	230	WEST	230	1	2						
2004-11	EATON PK	230	CREWSLK	230	1	13						
2004-11	EATON PK	230	EATON PK	69	1	13						
2004-11	EATON PK	230	TENOROC	230	1	13						
2004-11	RECKER	230	GAPWAY	230	1	16						
2004-11	SN PLANT	115	TURNER	115	1	1						
2004-12	SN PLANT	230	SYLVAN	230	1	1						
2004-12	SYLVAN	230	N LONGWD	230	1	1						
2004-12	IND RIV	230	STANTON	230	1	11						
2004-12	SN PLANT	115	TURNER	115	1	1						
2004-12	BUCKEYE	230	RUSKMTR8	230	1	1						
2004-12	SILVR SP	230	SILV SPN	230	1	2						
2004-12	SILVR SP	230	OCALA 1	230	1	2						
2004-12	RIO PINR	230	CURRY FD	230	1	2						
2004-12	STANTON	230	CURRY FD	230	1	2						
2004-12	OSCEOLA	230	LKAGNES	230	1	16						
2004-12	SHELD	230	LK TARP	230	1	2						
2004-12	PEBB	230	CREWSLK	230	1	13						
2004-12	PEBB	230	N BARTOW	230	1	2						
2004-12	RECKER	230	LKAGNES	230	1	16						
2004-12	RECKER	230	ARIANA	230	1	16						
2004-12	RECKER	230	CREWSLK	230	1	13						
2004-12	B BEND	230	MANATEE	230	1	1						
2004-12	RUSKIN T	230	MANATEE	230	1	1						
2004-12	IND RIV	230	IND RIV	115	1	11						
2004-12	SHELD	230	SHELD-NW	69	1	16						
2004-12	LARGO	230	LARGO A	69	1	2						
2004-12	CLMT EST	230	CLMT EST	69	1	2						
2004-12	11TH AVE	230	ELEVEN-E	69	1	16						
2004-12	WINDERME	230	WINDERME	69	1	2						
2004-12	PASADENA	230	PASADENA	115	1	2						
2004-12	ARIANA	230	ARIANA-N	69	1	16						
2004-12	SELOSE	230	SELOSE-N	69	1	16						
2004-12	GAPWAY	230	GAPWAY	69	1	16						
2004-12	CREWSLK	230	CREWSLK	69	1	13						
2004-12	TENOROC	230	TENOROC	69	1	13						
2004-12	BARCOLA	230	WEST	230	1	2						
2004-12	EATON PK	230	CREWSLK	230	1	13						
2004-12	EATON PK	230	EATON PK	69	1	13						
2004-12	EATON PK	230	TENOROC	230	1	13						
2004-12	RECKER	230	GAPWAY	230	1	16						
2004-12	SN PLANT	115	TURNER	115	1	1						

Table I
Comparison of Line & Transformer Flows
Following N-1 Disturbances
for Various OEC 500 MW Generation Alternatives

100% Load Base Case

All Flows above 100% of Emergency rating are Shown

Monitored Branches							Case 2004 Base No OEC Gen	Case 2004A Sell to FPL	Case 2004B Sell to FPC	Case 2004C Sell to TEC	Case 2004D Sell to JEA	Case 2004E Sell to SEM
Case	Bus 1	kV 1	Bus 2	kV 2	ckt	Area	Percent	Percent	Percent	Percent	Percent	Percent
2004-13	SN PLANT	230	SYLVAN	230	1	1						
2004-13	SYLVAN	230	N LONGWD	230	1	1						
2004-13	IND RIV	230	STANTON	230	1	11						
2004-13	SN PLANT	115	TURNER	115	1	1						
2004-13	BUCKEYE	230	RUSKMTR8	230	1	1						
2004-13	SILVR SP	230	SILV SPN	230	1	2						
2004-13	SILVR SP	230	OCALA 1	230	1	2						
2004-13	RIO PINR	230	CURRY FD	230	1	2						
2004-13	STANTON	230	CURRY FD	230	1	2						
2004-13	OSCEOLA	230	LKAGNES	230	1	16						
2004-13	SHELD	230	LK TARP	230	1	2						
2004-13	PEBB	230	CREWSLK	230	1	13						
2004-13	PEBB	230	N BARTOW	230	1	2						
2004-13	RECKER	230	LKAGNES	230	1	16						
2004-13	RECKER	230	ARIANA	230	1	16						
2004-13	RECKER	230	CREWSLK	230	1	13						
2004-13	B BEND	230	MANATEE	230	1	1						
2004-13	RUSKIN T	230	MANATEE	230	1	1						
2004-13	IND RIV	230	IND RIV	115	1	11						
2004-13	SHELD	230	SHELD-NW	69	1	16						
2004-13	LARGO	230	LARGO A	69	1	2						
2004-13	CLMT EST	230	CLMT EST	69	1	2						
2004-13	11TH AVE	230	ELEVEN-E	69	1	16						
2004-13	WINDERME	230	WINDERME	69	1	2						
2004-13	PASADENA	230	PASADENA	115	1	2						
2004-13	ARIANA	230	ARIANA-N	69	1	16						
2004-13	SELOSE	230	SELOSE-N	69	1	16						
2004-13	GAPWAY	230	GAPWAY	69	1	16						
2004-13	CREWSLK	230	CREWSLK	69	1	13						
2004-13	TENOROC	230	TENOROC	69	1	13						
2004-13	BARCOLA	230	WEST	230	1	2						
2004-13	EATON PK	230	CREWSLK	230	1	13						
2004-13	EATON PK	230	EATON PK	69	1	13						
2004-13	EATON PK	230	TENOROC	230	1	13						
2004-13	RECKER	230	GAPWAY	230	1	16						
2004-13	SN PLANT	115	TURNER	115	1	1						
2004-15	SN PLANT	230	SYLVAN	230	1	1						
2004-15	SYLVAN	230	N LONGWD	230	1	1						
2004-15	IND RIV	230	STANTON	230	1	11						
2004-15	SN PLANT	115	TURNER	115	1	1						
2004-15	BUCKEYE	230	RUSKMTR8	230	1	1						
2004-15	SILVR SP	230	SILV SPN	230	1	2						
2004-15	SILVR SP	230	OCALA 1	230	1	2						
2004-15	RIO PINR	230	CURRY FD	230	1	2						
2004-15	STANTON	230	CURRY FD	230	1	2						
2004-15	OSCEOLA	230	LKAGNES	230	1	16						
2004-15	SHELD	230	LK TARP	230	1	2						
2004-15	PEBB	230	CREWSLK	230	1	13						
2004-15	PEBB	230	N BARTOW	230	1	2						
2004-15	RECKER	230	LKAGNES	230	1	16						
2004-15	RECKER	230	ARIANA	230	1	16						
2004-15	RECKER	230	CREWSLK	230	1	13						
2004-15	B BEND	230	MANATEE	230	1	1						
2004-15	RUSKIN T	230	MANATEE	230	1	1						
2004-15	IND RIV	230	IND RIV	115	1	11						
2004-15	SHELD	230	SHELD-NW	69	1	16						
2004-15	LARGO	230	LARGO A	69	1	2						
2004-15	CLMT EST	230	CLMT EST	69	1	2						
2004-15	11TH AVE	230	ELEVEN-E	69	1	16						
2004-15	WINDERME	230	WINDERME	69	1	2						
2004-15	PASADENA	230	PASADENA	115	1	2						
2004-15	ARIANA	230	ARIANA-N	69	1	16						
2004-15	SELOSE	230	SELOSE-N	69	1	16						
2004-15	GAPWAY	230	GAPWAY	69	1	16						
2004-15	CREWSLK	230	CREWSLK	69	1	13						
2004-15	TENOROC	230	TENOROC	69	1	13						
2004-15	BARCOLA	230	WEST	230	1	2						
2004-15	EATON PK	230	CREWSLK	230	1	13						
2004-15	EATON PK	230	EATON PK	69	1	13						
2004-15	EATON PK	230	TENOROC	230	1	13						
2004-15	RECKER	230	GAPWAY	230	1	16						
2004-15	SN PLANT	115	TURNER	115	1	1						

Table I
Comparison of Line & Transformer Flows
Following N-1 Disturbances
for Various OEC 500 MW Generation Alternatives

100% Load Base Case

All Flows above 100% of Emergency rating are Shown

Monitored Branches							Case 2004 Base No OEC Gen	Case 2004A Sell to FPL	Case 2004B Sell to FPC	Case 2004C Sell to TEC	Case 2004D Sell to JEA	Case 2004E Sell to SEM
Case	Bus 1	kV 1	Bus 2	kV 2	ckt	Area	Percent	Percent	Percent	Percent	Percent	Percent
2004-16	SN PLANT	230	SYLVAN	230	1	1						
2004-16	SYLVAN	230	N LONGWD	230	1	1						
2004-16	IND RIV	230	STANTON	230	1	11						
2004-16	SN PLANT	115	TURNER	115	1	1						
2004-16	BUCKEYE	230	RUSKMTR8	230	1	1						
2004-16	SILVR SP	230	SILV SPN	230	1	2						
2004-16	SILVR SP	230	OCALA 1	230	1	2						
2004-16	RIO PINR	230	CURRY FD	230	1	2						
2004-16	STANTON	230	CURRY FD	230	1	2						
2004-16	OSCEOLA	230	LKAGNES	230	1	16						
2004-16	SHELD	230	LK TARPEN	230	1	2						
2004-16	PEBB	230	CREWSLK	230	1	13						
2004-16	PEBB	230	N BARTOW	230	1	2						
2004-16	RECKER	230	LKAGNES	230	1	16						
2004-16	RECKER	230	ARIANA	230	1	16						
2004-16	RECKER	230	CREWSLK	230	1	13						
2004-16	B BEND	230	MANATEE	230	1	1						
2004-16	RUSKIN T	230	MANATEE	230	1	1						
2004-16	IND RIV	230	IND RIV	115	1	11						
2004-16	SHELD	230	SHELD-NW	69	1	16						
2004-16	LARGO	230	LARGO A	69	1	2						
2004-16	CLMT EST	230	CLMT EST	69	1	2						
2004-16	11TH AVE	230	ELEVEN-E	69	1	16						
2004-16	WINDERME	230	WINDERME	69	1	2						
2004-16	PASADENA	230	PASADENA	115	1	2						
2004-16	ARIANA	230	ARIANA-N	69	1	16						
2004-16	SELOSE	230	SELOSE-N	69	1	16						
2004-16	GAPWAY	230	GAPWAY	69	1	16						
2004-16	CREWSLK	230	CREWSLK	69	1	13						
2004-16	TENOROC	230	TENOROC	69	1	13						
2004-16	BARCOLA	230	WEST	230	1	2						
2004-16	EATON PK	230	CREWSLK	230	1	13						
2004-16	EATON PK	230	EATON PK	69	1	13						
2004-16	EATON PK	230	TENOROC	230	1	13						
2004-16	RECKER	230	GAPWAY	230	1	16						
2004-16	SN PLANT	115	TURNER	115	1	1						
2004-17	SN PLANT	230	SYLVAN	230	1	1						
2004-17	SYLVAN	230	N LONGWD	230	1	1						
2004-17	IND RIV	230	STANTON	230	1	11						
2004-17	SN PLANT	115	TURNER	115	1	1						
2004-17	BUCKEYE	230	RUSKMTR8	230	1	1						
2004-17	SILVR SP	230	SILV SPN	230	1	2						
2004-17	SILVR SP	230	OCALA 1	230	1	2						
2004-17	RIO PINR	230	CURRY FD	230	1	2						
2004-17	STANTON	230	CURRY FD	230	1	2						
2004-17	OSCEOLA	230	LKAGNES	230	1	16						
2004-17	SHELD	230	LK TARPEN	230	1	2						
2004-17	PEBB	230	CREWSLK	230	1	13						
2004-17	PEBB	230	N BARTOW	230	1	2						
2004-17	RECKER	230	LKAGNES	230	1	16						
2004-17	RECKER	230	ARIANA	230	1	16						
2004-17	RECKER	230	CREWSLK	230	1	13						
2004-17	B BEND	230	MANATEE	230	1	1						
2004-17	RUSKIN T	230	MANATEE	230	1	1						
2004-17	IND RIV	230	IND RIV	115	1	11						
2004-17	SHELD	230	SHELD-NW	69	1	16						
2004-17	LARGO	230	LARGO A	69	1	2						
2004-17	CLMT EST	230	CLMT EST	69	1	2						
2004-17	11TH AVE	230	ELEVEN-E	69	1	16						
2004-17	WINDERME	230	WINDERME	69	1	2						
2004-17	PASADENA	230	PASADENA	115	1	2						
2004-17	ARIANA	230	ARIANA-N	69	1	16						
2004-17	SELOSE	230	SELOSE-N	69	1	16						
2004-17	GAPWAY	230	GAPWAY	69	1	16						
2004-17	CREWSLK	230	CREWSLK	69	1	13						
2004-17	TENOROC	230	TENOROC	69	1	13						
2004-17	BARCOLA	230	WEST	230	1	2						
2004-17	EATON PK	230	CREWSLK	230	1	13						
2004-17	EATON PK	230	EATON PK	69	1	13						
2004-17	EATON PK	230	TENOROC	230	1	13						
2004-17	RECKER	230	GAPWAY	230	1	16						
2004-17	SN PLANT	115	TURNER	115	1	1						

Table I
Comparison of Line & Transformer Flows
Following N-1 Disturbances
for Various OEC 500 MW Generation Alternatives

100% Load Base Case

All Flows above 100% of Emergency rating are Shown

Monitored Branches							Case 2004 Base No OEC Gen	Case 2004A Sell to FPL	Case 2004B Sell to FPC	Case 2004C Sell to TEC	Case 2004D Sell to JEA	Case 2004E Sell to SEM
Case	Bus 1	kV 1	Bus 2	kV 2	ckt	Area	Percent	Percent	Percent	Percent	Percent	Percent
2004-18	SN PLANT	230	SYLVAN	230	1	1						
2004-18	SYLVAN	230	N LONGWD	230	1	1						
2004-18	IND RIV	230	STANTON	230	1	11						
2004-18	SN PLANT	115	TURNER	115	1	1						
2004-18	BUCKEYE	230	RUSKMTR8	230	1	1						
2004-18	SILVR SP	230	SILV SPN	230	1	2						
2004-18	SILVR SP	230	OCALA 1	230	1	2						
2004-18	RIO PINR	230	CURRY FD	230	1	2						
2004-18	STANTON	230	CURRY FD	230	1	2						
2004-18	OSCEOLA	230	LKAGNES	230	1	16						
2004-18	SHELD	230	LK TARPEN	230	1	2						
2004-18	PEBB	230	CREWSLK	230	1	13						
2004-18	PEBB	230	N BARTOW	230	1	2						
2004-18	RECKER	230	LKAGNES	230	1	16		100.0	103.2		102.6	102.1
2004-18	RECKER	230	ARIANA	230	1	16						
2004-18	RECKER	230	CREWSLK	230	1	13						
2004-18	B BEND	230	MANATEE	230	1	1						
2004-18	RUSKIN T	230	MANATEE	230	1	1						
2004-18	IND RIV	230	IND RIV	115	1	11						
2004-18	SHELD	230	SHELD-NW	69	1	16						
2004-18	LARGO	230	LARGO A	69	1	2						
2004-18	CLMT EST	230	CLMT EST	69	1	2						
2004-18	11TH AVE	230	ELEVEN-E	69	1	16						
2004-18	WINDERME	230	WINDERME	69	1	2						
2004-18	PASADENA	230	PASADENA	115	1	2						
2004-18	ARIANA	230	ARIANA-N	69	1	16						
2004-18	SELOSE	230	SELOSE-N	69	1	16						
2004-18	GAPWAY	230	GAPWAY	69	1	16						
2004-18	CREWSLK	230	CREWSLK	69	1	13						
2004-18	TENOROC	230	TENOROC	69	1	13						
2004-18	BARCOLA	230	WEST	230	1	2						
2004-18	EATON PK	230	CREWSLK	230	1	13						
2004-18	EATON PK	230	EATON PK	69	1	13						
2004-18	EATON PK	230	TENOROC	230	1	13						
2004-18	RECKER	230	GAPWAY	230	1	16						
2004-18	SN PLANT	115	TURNER	115	1	1						
2004-19	SN PLANT	230	SYLVAN	230	1	1						
2004-19	SYLVAN	230	N LONGWD	230	1	1						
2004-19	IND RIV	230	STANTON	230	1	11						
2004-19	SN PLANT	115	TURNER	115	1	1						
2004-19	BUCKEYE	230	RUSKMTR8	230	1	1						
2004-19	SILVR SP	230	SILV SPN	230	1	2						
2004-19	SILVR SP	230	OCALA 1	230	1	2						
2004-19	RIO PINR	230	CURRY FD	230	1	2						
2004-19	STANTON	230	CURRY FD	230	1	2						
2004-19	OSCEOLA	230	LKAGNES	230	1	16						
2004-19	SHELD	230	LK TARPEN	230	1	2						
2004-19	PEBB	230	CREWSLK	230	1	13						
2004-19	PEBB	230	N BARTOW	230	1	2						
2004-19	RECKER	230	LKAGNES	230	1	16						
2004-19	RECKER	230	ARIANA	230	1	16						
2004-19	RECKER	230	CREWSLK	230	1	13						
2004-19	B BEND	230	MANATEE	230	1	1						
2004-19	RUSKIN T	230	MANATEE	230	1	1						
2004-19	IND RIV	230	IND RIV	115	1	11						
2004-19	SHELD	230	SHELD-NW	69	1	16						
2004-19	LARGO	230	LARGO A	69	1	2						
2004-19	CLMT EST	230	CLMT EST	69	1	2						
2004-19	11TH AVE	230	ELEVEN-E	69	1	16						
2004-19	WINDERME	230	WINDERME	69	1	2						
2004-19	PASADENA	230	PASADENA	115	1	2						
2004-19	ARIANA	230	ARIANA-N	69	1	16						
2004-19	SELOSE	230	SELOSE-N	69	1	16						
2004-19	GAPWAY	230	GAPWAY	69	1	16						
2004-19	CREWSLK	230	CREWSLK	69	1	13						
2004-19	TENOROC	230	TENOROC	69	1	13						
2004-19	BARCOLA	230	WEST	230	1	2						
2004-19	EATON PK	230	CREWSLK	230	1	13						
2004-19	EATON PK	230	EATON PK	69	1	13						
2004-19	EATON PK	230	TENOROC	230	1	13						
2004-19	RECKER	230	GAPWAY	230	1	16						
2004-19	SN PLANT	115	TURNER	115	1	1						

Table I
Comparison of Line & Transformer Flows
Following N-1 Disturbances
for Various OEC 500 MW Generation Alternatives

100% Load Base Case

All Flows above 100% of Emergency rating are Shown

Monitored Branches							Case 2004 Base No OEC Gen	Case 2004A Sell to FPL	Case 2004B Sell to FPC	Case 2004C Sell to TEC	Case 2004D Sell to JEA	Case 2004E Sell to SEM
Case	Bus 1	KV 1	Bus 2	KV 2	ckt	Area	Percent	Percent	Percent	Percent	Percent	Percent
2004-20	SN PLANT	230	SYLVAN	230	1	1						
2004-20	SYLVAN	230	N LONGWD	230	1	1						
2004-20	IND RIV	230	STANTON	230	1	11						
2004-20	SN PLANT	115	TURNER	115	1	1						
2004-20	BUCKEYE	230	RUSKMTR8	230	1	1						
2004-20	SILVR SP	230	SILV SPN	230	1	2						
2004-20	SILVR SP	230	OCALA 1	230	1	2						
2004-20	RIO PINR	230	CURRY FD	230	1	2						
2004-20	STANTON	230	CURRY FD	230	1	2						
2004-20	OSCEOLA	230	LKAGNES	230	1	16						
2004-20	SHELD	230	LK TARPEN	230	1	2						
2004-20	PEBB	230	CREWSLK	230	1	13						
2004-20	PEBB	230	N BARTOW	230	1	2						
2004-20	RECKER	230	LKAGNES	230	1	16						
2004-20	RECKER	230	ARIANA	230	1	16						
2004-20	RECKER	230	CREWSLK	230	1	13						
2004-20	B BEND	230	MANATEE	230	1	1						
2004-20	RUSKIN T	230	MANATEE	230	1	1						
2004-20	IND RIV	230	IND RIV	115	1	11						
2004-20	SHELD	230	SHELD-NW	69	1	16						
2004-20	LARGO	230	LARGO A	69	1	2						
2004-20	CLMT EST	230	CLMT EST	69	1	2						
2004-20	11TH AVE	230	ELEVEN-E	69	1	16						
2004-20	WINDERME	230	WINDERME	69	1	2						
2004-20	PASADENA	230	PASADENA	115	1	2						
2004-20	ARIANA	230	ARIANA-N	69	1	16						
2004-20	SELOSE	230	SELOSE-N	69	1	16						
2004-20	GAPWAY	230	GAPWAY	69	1	16						
2004-20	CREWSLK	230	CREWSLK	69	1	13						
2004-20	TENOROC	230	TENOROC	69	1	13						
2004-20	BARCOLA	230	WEST	230	1	2						
2004-20	EATON PK	230	CREWSLK	230	1	13						
2004-20	EATON PK	230	EATON PK	69	1	13						
2004-20	EATON PK	230	TENOROC	230	1	13						
2004-20	RECKER	230	GAPWAY	230	1	16						
2004-20	SN PLANT	115	TURNER	115	1	1						
2004-21	SN PLANT	230	SYLVAN	230	1	1						
2004-21	SYLVAN	230	N LONGWD	230	1	1						
2004-21	IND RIV	230	STANTON	230	1	11						
2004-21	SN PLANT	115	TURNER	115	1	1						
2004-21	BUCKEYE	230	RUSKMTR8	230	1	1						
2004-21	SILVR SP	230	SILV SPN	230	1	2						
2004-21	SILVR SP	230	OCALA 1	230	1	2						
2004-21	RIO PINR	230	CURRY FD	230	1	2						
2004-21	STANTON	230	CURRY FD	230	1	2						
2004-21	OSCEOLA	230	LKAGNES	230	1	16						
2004-21	SHELD	230	LK TARPEN	230	1	2						
2004-21	PEBB	230	CREWSLK	230	1	13						
2004-21	PEBB	230	N BARTOW	230	1	2						
2004-21	RECKER	230	LKAGNES	230	1	16						
2004-21	RECKER	230	ARIANA	230	1	16						
2004-21	RECKER	230	CREWSLK	230	1	13						
2004-21	B BEND	230	MANATEE	230	1	1						
2004-21	RUSKIN T	230	MANATEE	230	1	1						
2004-21	IND RIV	230	IND RIV	115	1	11						
2004-21	SHELD	230	SHELD-NW	69	1	16						
2004-21	LARGO	230	LARGO A	69	1	2						
2004-21	CLMT EST	230	CLMT EST	69	1	2						
2004-21	11TH AVE	230	ELEVEN-E	69	1	16						
2004-21	WINDERME	230	WINDERME	69	1	2						
2004-21	PASADENA	230	PASADENA	115	1	2						
2004-21	ARIANA	230	ARIANA-N	69	1	16						
2004-21	SELOSE	230	SELOSE-N	69	1	16						
2004-21	GAPWAY	230	GAPWAY	69	1	16						
2004-21	CREWSLK	230	CREWSLK	69	1	13						
2004-21	TENOROC	230	TENOROC	69	1	13						
2004-21	BARCOLA	230	WEST	230	1	2						
2004-21	EATON PK	230	CREWSLK	230	1	13						
2004-21	EATON PK	230	EATON PK	69	1	13						
2004-21	EATON PK	230	TENOROC	230	1	13						
2004-21	RECKER	230	GAPWAY	230	1	16						
2004-21	SN PLANT	115	TURNER	115	1	1						

Table I
Comparison of Line & Transformer Flows
Following N-1 Disturbances
for Various OEC 500 MW Generation Alternatives

100% Load Base Case

All Flows above 100% of Emergency rating are Shown

Monitored Branches							Case 2004	Case 2004A	Case 2004B	Case 2004C	Case 2004D	Case 2004E
Case	Bus 1	kV 1	Bus 2	kV 2	ckt	Area	Base No OEC Gen Percent	Sell to FPL Percent	Sell to FPC Percent	Sell to TEC Percent	Sell to JEA Percent	Sell to SEM Percent
2004-22	SN PLANT	230	SYLVAN	230	1	1						
2004-22	SYLVAN	230	N LONGWD	230	1	1						
2004-22	IND RIV	230	STANTON	230	1	11						
2004-22	SN PLANT	115	TURNER	115	1	1						
2004-22	BUCKEYE	230	RUSKMTRB	230	1	1						
2004-22	SILVR SP	230	SILV SPN	230	1	2						
2004-22	SILVR SP	230	OCALA 1	230	1	2						
2004-22	RIO PINR	230	CURRY FD	230	1	2						
2004-22	STANTON	230	CURRY FD	230	1	2						
2004-22	OSCEOLA	230	LKAGNES	230	1	16						
2004-22	SHELD	230	LK TARP	230	1	2						
2004-22	PEBB	230	CREWSLK	230	1	13						
2004-22	PEBB	230	N BARTOW	230	1	2						
2004-22	RECKER	230	LKAGNES	230	1	16						
2004-22	RECKER	230	ARIANA	230	1	16						
2004-22	RECKER	230	CREWSLK	230	1	13						
2004-22	B BEND	230	MANATEE	230	1	1						
2004-22	RUSKIN T	230	MANATEE	230	1	1						
2004-22	IND RIV	230	IND RIV	115	1	11						
2004-22	SHELD	230	SHELD-NW	69	1	16						
2004-22	LARGO	230	LARGO A	69	1	2						
2004-22	CLMT EST	230	CLMT EST	69	1	2						
2004-22	11TH AVE	230	ELEVEN-E	69	1	16						
2004-22	WINDERME	230	WINDERME	69	1	2						
2004-22	PASADENA	230	PASADENA	115	1	2						
2004-22	ARIANA	230	ARIANA-N	69	1	16						
2004-22	SELOSE	230	SELOSE-N	69	1	16						
2004-22	GAPWAY	230	GAPWAY	69	1	16						
2004-22	CREWSLK	230	CREWSLK	69	1	13						
2004-22	TENOROC	230	TENOROC	69	1	13						
2004-22	BARCOLA	230	WEST	230	1	2						
2004-22	EATON PK	230	CREWSLK	230	1	13						
2004-22	EATON PK	230	EATON PK	69	1	13						
2004-22	EATON PK	230	TENOROC	230	1	13						
2004-22	RECKER	230	GAPWAY	230	1	16						
2004-22	SN PLANT	115	TURNER	115	1	1						
2004-23	SN PLANT	230	SYLVAN	230	1	1						
2004-23	SYLVAN	230	N LONGWD	230	1	1						
2004-23	IND RIV	230	STANTON	230	1	11						
2004-23	SN PLANT	115	TURNER	115	1	1						
2004-23	BUCKEYE	230	RUSKMTRB	230	1	1						
2004-23	SILVR SP	230	SILV SPN	230	1	2						
2004-23	SILVR SP	230	OCALA 1	230	1	2						
2004-23	RIO PINR	230	CURRY FD	230	1	2						
2004-23	STANTON	230	CURRY FD	230	1	2						
2004-23	OSCEOLA	230	LKAGNES	230	1	16						
2004-23	SHELD	230	LK TARP	230	1	2						
2004-23	PEBB	230	CREWSLK	230	1	13						
2004-23	PEBB	230	N BARTOW	230	1	2						
2004-23	RECKER	230	LKAGNES	230	1	16						
2004-23	RECKER	230	ARIANA	230	1	16						
2004-23	RECKER	230	CREWSLK	230	1	13						
2004-23	B BEND	230	MANATEE	230	1	1						
2004-23	RUSKIN T	230	MANATEE	230	1	1						
2004-23	IND RIV	230	IND RIV	115	1	11						
2004-23	SHELD	230	SHELD-NW	69	1	16						
2004-23	LARGO	230	LARGO A	69	1	2						
2004-23	CLMT EST	230	CLMT EST	69	1	2						
2004-23	11TH AVE	230	ELEVEN-E	69	1	16						
2004-23	WINDERME	230	WINDERME	69	1	2						
2004-23	PASADENA	230	PASADENA	115	1	2						
2004-23	ARIANA	230	ARIANA-N	69	1	16						
2004-23	SELOSE	230	SELOSE-N	69	1	16						
2004-23	GAPWAY	230	GAPWAY	69	1	16						
2004-23	CREWSLK	230	CREWSLK	69	1	13						
2004-23	TENOROC	230	TENOROC	69	1	13						
2004-23	BARCOLA	230	WEST	230	1	2						
2004-23	EATON PK	230	CREWSLK	230	1	13						
2004-23	EATON PK	230	EATON PK	69	1	13						
2004-23	EATON PK	230	TENOROC	230	1	13						
2004-23	RECKER	230	GAPWAY	230	1	16						
2004-23	SN PLANT	115	TURNER	115	1	1						

Table I
Comparison of Line & Transformer Flows
Following N-1 Disturbances
for Various OEC 500 MW Generation Alternatives

100% Load Base Case

All Flows above 100% of Emergency rating are Shown

Monitored Branches							Case 2004 Base No OEC Gen	Case 2004A Sell to FPL	Case 2004B Sell to FPC	Case 2004C Sell to TEC	Case 2004D Sell to JEA	Case 2004E Sell to SEM
Case	Bus 1	kV 1	Bus 2	kV 2	ckt	Area	Percent	Percent	Percent	Percent	Percent	Percent
2004-24	SN PLANT	230	SYLVAN	230	1	1						
2004-24	SYLVAN	230	N LONGWD	230	1	1						
2004-24	IND RIV	230	STANTON	230	1	11						
2004-24	SN PLANT	115	TURNER	115	1	1						
2004-24	BUCKEYE	230	RUSKMTRB	230	1	1						
2004-24	SILVR SP	230	SILV SPN	230	1	2						
2004-24	SILVR SP	230	OCALA 1	230	1	2						
2004-24	RIO PINR	230	CURRY FD	230	1	2						
2004-24	STANTON	230	CURRY FD	230	1	2						
2004-24	OSCEOLA	230	LKAGNES	230	1	16						
2004-24	SHELD	230	LK TARPEN	230	1	2						
2004-24	PEBB	230	CREWSLK	230	1	13						
2004-24	PEBB	230	N BARTOW	230	1	2						
2004-24	RECKER	230	LKAGNES	230	1	16						
2004-24	RECKER	230	ARIANA	230	1	16						
2004-24	RECKER	230	CREWSLK	230	1	13						
2004-24	B BEND	230	MANATEE	230	1	1						
2004-24	RUSKIN T	230	MANATEE	230	1	1						
2004-24	IND RIV	230	IND RIV	115	1	11						
2004-24	SHELD	230	SHELD-NW	69	1	16						
2004-24	LARGO	230	LARGO A	69	1	2						
2004-24	CLMT EST	230	CLMT EST	69	1	2						
2004-24	11TH AVE	230	ELEVEN-E	69	1	16						
2004-24	WINDERME	230	WINDERME	69	1	2						
2004-24	PASADENA	230	PASADENA	115	1	2						
2004-24	ARIANA	230	ARIANA-N	69	1	16						
2004-24	SELOSE	230	SELOSE-N	69	1	16						
2004-24	GAPWAY	230	GAPWAY	69	1	16						
2004-24	CREWSLK	230	CREWSLK	69	1	13						
2004-24	TENOROC	230	TENOROC	69	1	13						
2004-24	BARCOLA	230	WEST	230	1	2						
2004-24	EATON PK	230	CREWSLK	230	1	13						
2004-24	EATON PK	230	EATON PK	69	1	13						
2004-24	EATON PK	230	TENOROC	230	1	13						
2004-24	RECKER	230	GAPWAY	230	1	16						
2004-24	SN PLANT	115	TURNER	115	1	1						
2004-25	SN PLANT	230	SYLVAN	230	1	1						
2004-25	SYLVAN	230	N LONGWD	230	1	1						
2004-25	IND RIV	230	STANTON	230	1	11						
2004-25	SN PLANT	115	TURNER	115	1	1						
2004-25	BUCKEYE	230	RUSKMTRB	230	1	1						
2004-25	SILVR SP	230	SILV SPN	230	1	2						
2004-25	SILVR SP	230	OCALA 1	230	1	2						
2004-25	RIO PINR	230	CURRY FD	230	1	2						
2004-25	STANTON	230	CURRY FD	230	1	2						
2004-25	OSCEOLA	230	LKAGNES	230	1	16						
2004-25	SHELD	230	LK TARPEN	230	1	2						
2004-25	PEBB	230	CREWSLK	230	1	13						
2004-25	PEBB	230	N BARTOW	230	1	2						
2004-25	RECKER	230	LKAGNES	230	1	16						
2004-25	RECKER	230	ARIANA	230	1	16						
2004-25	RECKER	230	CREWSLK	230	1	13						
2004-25	B BEND	230	MANATEE	230	1	1						
2004-25	RUSKIN T	230	MANATEE	230	1	1						
2004-25	IND RIV	230	IND RIV	115	1	11						
2004-25	SHELD	230	SHELD-NW	69	1	16						
2004-25	LARGO	230	LARGO A	69	1	2						
2004-25	CLMT EST	230	CLMT EST	69	1	2						
2004-25	11TH AVE	230	ELEVEN-E	69	1	16						
2004-25	WINDERME	230	WINDERME	69	1	2						
2004-25	PASADENA	230	PASADENA	115	1	2						
2004-25	ARIANA	230	ARIANA-N	69	1	16						
2004-25	SELOSE	230	SELOSE-N	69	1	16						
2004-25	GAPWAY	230	GAPWAY	69	1	16						
2004-25	CREWSLK	230	CREWSLK	69	1	13						
2004-25	TENOROC	230	TENOROC	69	1	13						
2004-25	BARCOLA	230	WEST	230	1	2						
2004-25	EATON PK	230	CREWSLK	230	1	13						
2004-25	EATON PK	230	EATON PK	69	1	13						
2004-25	EATON PK	230	TENOROC	230	1	13						
2004-25	RECKER	230	GAPWAY	230	1	16						
2004-25	SN PLANT	115	TURNER	115	1	1						

Table I
Comparison of Line & Transformer Flows
Following N-1 Disturbances
for Various OEC 500 MW Generation Alternatives

100% Load Base Case

All Flows above 100% of Emergency rating are Shown

Monitored Branches							Case 2004	Case 2004A	Case 2004B	Case 2004C	Case 2004D	Case 2004E
Case	Bus 1	kV 1	Bus 2	kV 2	ckt	Area	Base No OEC Gen Percent	Sell to FPL Percent	Sell to FPC Percent	Sell to TEC Percent	Sell to JEA Percent	Sell to SEM Percent
2004-26	SN PLANT	230	SYLVAN	230	1	1						
2004-26	SYLVAN	230	N LONGWD	230	1	1						
2004-26	IND RIV	230	STANTON	230	1	11						
2004-26	SN PLANT	115	TURNER	115	1	1						
2004-26	BUCKEYE	230	RUSKMTR8	230	1	1						
2004-26	SILVR SP	230	SILV SPN	230	1	2						
2004-26	SILVR SP	230	OCALA 1	230	1	2						
2004-26	RIO PINR	230	CURRY FD	230	1	2						
2004-26	STANTON	230	CURRY FD	230	1	2						
2004-26	OSCEOLA	230	LKAGNES	230	1	16						
2004-26	SHELD	230	LK TARP	230	1	2						
2004-26	PEBB	230	CREWSLK	230	1	13						
2004-26	PEBB	230	N BARTOW	230	1	2						
2004-26	RECKER	230	LKAGNES	230	1	16						
2004-26	RECKER	230	ARIANA	230	1	16						
2004-26	RECKER	230	CREWSLK	230	1	13						
2004-26	B BEND	230	MANATEE	230	1	1						
2004-26	RUSKIN T	230	MANATEE	230	1	1						
2004-26	IND RIV	230	IND RIV	115	1	11						
2004-26	SHELD	230	SHELD-NW	69	1	16						
2004-26	LARGO	230	LARGO A	69	1	2						
2004-26	CLMT EST	230	CLMT EST	69	1	2						
2004-26	11TH AVE	230	ELEVEN-E	69	1	16						
2004-26	WINDERME	230	WINDERME	69	1	2						
2004-26	PASADENA	230	PASADENA	115	1	2						
2004-26	ARIANA	230	ARIANA-N	69	1	16						
2004-26	SELOSE	230	SELOSE-N	69	1	16						
2004-26	GAPWAY	230	GAPWAY	69	1	16						
2004-26	CREWSLK	230	CREWSLK	69	1	13						
2004-26	TENOROC	230	TENOROC	69	1	13						
2004-26	BARCOLA	230	WEST	230	1	2						
2004-26	EATON PK	230	CREWSLK	230	1	13						
2004-26	EATON PK	230	EATON PK	69	1	13						
2004-26	EATON PK	230	TENOROC	230	1	13						
2004-26	RECKER	230	GAPWAY	230	1	16						
2004-26	SN PLANT	115	TURNER	115	1	1						
2004-27	SN PLANT	230	SYLVAN	230	1	1						
2004-27	SYLVAN	230	N LONGWD	230	1	1						
2004-27	IND RIV	230	STANTON	230	1	11						
2004-27	SN PLANT	115	TURNER	115	1	1						
2004-27	BUCKEYE	230	RUSKMTR8	230	1	1						
2004-27	SILVR SP	230	SILV SPN	230	1	2						
2004-27	SILVR SP	230	OCALA 1	230	1	2						
2004-27	RIO PINR	230	CURRY FD	230	1	2						
2004-27	STANTON	230	CURRY FD	230	1	2						
2004-27	OSCEOLA	230	LKAGNES	230	1	16						
2004-27	SHELD	230	LK TARP	230	1	2						
2004-27	PEBB	230	CREWSLK	230	1	13						
2004-27	PEBB	230	N BARTOW	230	1	2						
2004-27	RECKER	230	LKAGNES	230	1	16						
2004-27	RECKER	230	ARIANA	230	1	16						
2004-27	RECKER	230	CREWSLK	230	1	13						
2004-27	B BEND	230	MANATEE	230	1	1						
2004-27	RUSKIN T	230	MANATEE	230	1	1						
2004-27	IND RIV	230	IND RIV	115	1	11						
2004-27	SHELD	230	SHELD-NW	69	1	16						
2004-27	LARGO	230	LARGO A	69	1	2						
2004-27	CLMT EST	230	CLMT EST	69	1	2						
2004-27	11TH AVE	230	ELEVEN-E	69	1	16						
2004-27	WINDERME	230	WINDERME	69	1	2						
2004-27	PASADENA	230	PASADENA	115	1	2						
2004-27	ARIANA	230	ARIANA-N	69	1	16						
2004-27	SELOSE	230	SELOSE-N	69	1	16						
2004-27	GAPWAY	230	GAPWAY	69	1	16						
2004-27	CREWSLK	230	CREWSLK	69	1	13						
2004-27	TENOROC	230	TENOROC	69	1	13						
2004-27	BARCOLA	230	WEST	230	1	2						
2004-27	EATON PK	230	CREWSLK	230	1	13						
2004-27	EATON PK	230	EATON PK	69	1	13						
2004-27	EATON PK	230	TENOROC	230	1	13						
2004-27	RECKER	230	GAPWAY	230	1	16						
2004-27	SN PLANT	115	TURNER	115	1	1						

Table I
Comparison of Line & Transformer Flows
Following N-1 Disturbances
for Various OEC 500 MW Generation Alternatives

100% Load Base Case

All Flows above 100% of Emergency rating are Shown

Monitored Branches							Case 2004 Base No OEC Gen	Case 2004A Sell to FPL	Case 2004B Sell to FPC	Case 2004C Sell to TEC	Case 2004D Sell to JEA	Case 2004E Sell to SEM
Case	Bus 1	kV 1	Bus 2	kV 2	ckt	Area	Percent	Percent	Percent	Percent	Percent	Percent
2004-28	SN PLANT	230	SYLVAN	230	1	1						
2004-28	SYLVAN	230	N LONGWD	230	1	1						
2004-28	IND RIV	230	STANTON	230	1	11						
2004-28	SN PLANT	115	TURNER	115	1	1						
2004-28	BUCKEYE	230	RUSKMTR8	230	1	1						
2004-28	SILVR SP	230	SILV SPN	230	1	2						
2004-28	SILVR SP	230	OCALA 1	230	1	2						
2004-28	RIO PINR	230	CURRY FD	230	1	2						
2004-28	STANTON	230	CURRY FD	230	1	2						
2004-28	OSCEOLA	230	LKAGNES	230	1	16						
2004-28	SHELD	230	LK TARPEN	230	1	2						
2004-28	PEBB	230	CREWSLK	230	1	13						
2004-28	PEBB	230	N BARTOW	230	1	2						
2004-28	RECKER	230	LKAGNES	230	1	16						
2004-28	RECKER	230	ARIANA	230	1	16						
2004-28	RECKER	230	CREWSLK	230	1	13						
2004-28	B BEND	230	MANATEE	230	1	1						
2004-28	RUSKIN T	230	MANATEE	230	1	1						
2004-28	IND RIV	230	IND RIV	115	1	11						
2004-28	SHELD	230	SHELD-NW	69	1	16						
2004-28	LARGO	230	LARGO A	69	1	2						
2004-28	CLMT EST	230	CLMT EST	69	1	2						
2004-28	11TH AVE	230	ELEVEN-E	69	1	16						
2004-28	WINDERME	230	WINDERME	69	1	2						
2004-28	PASADENA	230	PASADENA	115	1	2						
2004-28	ARIANA	230	ARIANA-N	69	1	16						
2004-28	SELOSE	230	SELOSE-N	69	1	16						
2004-28	GAPWAY	230	GAPWAY	69	1	16						
2004-28	CREWSLK	230	CREWSLK	69	1	13						
2004-28	TENOROC	230	TENOROC	69	1	13						
2004-28	BARCOLA	230	WEST	230	1	2						
2004-28	EATON PK	230	CREWSLK	230	1	13						
2004-28	EATON PK	230	EATON PK	69	1	13						
2004-28	EATON PK	230	TENOROC	230	1	13						
2004-28	RECKER	230	GAPWAY	230	1	16						
2004-28	SN PLANT	115	TURNER	115	1	1						
2004-29	SN PLANT	230	SYLVAN	230	1	1						
2004-29	SYLVAN	230	N LONGWD	230	1	1						
2004-29	IND RIV	230	STANTON	230	1	11						
2004-29	SN PLANT	115	TURNER	115	1	1						
2004-29	BUCKEYE	230	RUSKMTR8	230	1	1						
2004-29	SILVR SP	230	SILV SPN	230	1	2						
2004-29	SILVR SP	230	OCALA 1	230	1	2						
2004-29	RIO PINR	230	CURRY FD	230	1	2						
2004-29	STANTON	230	CURRY FD	230	1	2						
2004-29	OSCEOLA	230	LKAGNES	230	1	16						
2004-29	SHELD	230	LK TARPEN	230	1	2						
2004-29	PEBB	230	CREWSLK	230	1	13						
2004-29	PEBB	230	N BARTOW	230	1	2						
2004-29	RECKER	230	LKAGNES	230	1	16						
2004-29	RECKER	230	ARIANA	230	1	16						
2004-29	RECKER	230	CREWSLK	230	1	13						
2004-29	B BEND	230	MANATEE	230	1	1						
2004-29	RUSKIN T	230	MANATEE	230	1	1						
2004-29	IND RIV	230	IND RIV	115	1	11						
2004-29	SHELD	230	SHELD-NW	69	1	16						
2004-29	LARGO	230	LARGO A	69	1	2						
2004-29	CLMT EST	230	CLMT EST	69	1	2						
2004-29	11TH AVE	230	ELEVEN-E	69	1	16						
2004-29	WINDERME	230	WINDERME	69	1	2						
2004-29	PASADENA	230	PASADENA	115	1	2						
2004-29	ARIANA	230	ARIANA-N	69	1	16		103.4	103.1	103.8	103.1	103.0
2004-29	SELOSE	230	SELOSE-N	69	1	16						
2004-29	GAPWAY	230	GAPWAY	69	1	16						
2004-29	CREWSLK	230	CREWSLK	69	1	13						
2004-29	TENOROC	230	TENOROC	69	1	13						
2004-29	BARCOLA	230	WEST	230	1	2						
2004-29	EATON PK	230	CREWSLK	230	1	13						
2004-29	EATON PK	230	EATON PK	69	1	13						
2004-29	EATON PK	230	TENOROC	230	1	13						
2004-29	RECKER	230	GAPWAY	230	1	16						
2004-29	SN PLANT	115	TURNER	115	1	1						

Table I
Comparison of Line & Transformer Flows
Following N-1 Disturbances
for Various OEC 500 MW Generation Alternatives

100% Load Base Case

All Flows above 100% of Emergency rating are Shown

Monitored Branches							Case 2004 Base No OEC Gen	Case 2004A Sell to FPL	Case 2004B Sell to FPC	Case 2004C Sell to TEC	Case 2004D Sell to JEA	Case 2004E Sell to SEM
Case	Bus 1	kV 1	Bus 2	kV 2	ckt	Area	Percent	Percent	Percent	Percent	Percent	Percent
2004-30	SN PLANT	230	SYLVAN	230	1	1						
2004-30	SYLVAN	230	N LONGWD	230	1	1						
2004-30	IND RIV	230	STANTON	230	1	11						
2004-30	SN PLANT	115	TURNER	115	1	1						
2004-30	BUCKEYE	230	RUSKMTR8	230	1	1						
2004-30	SILVR SP	230	SILV SPN	230	1	2						
2004-30	SILVR SP	230	OCALA 1	230	1	2						
2004-30	RIO PINR	230	CURRY FD	230	1	2						
2004-30	STANTON	230	CURRY FD	230	1	2						
2004-30	OSCEOLA	230	LKAGNES	230	1	16						
2004-30	SHELD	230	LK TARP	230	1	2						
2004-30	PEBB	230	CREWSLK	230	1	13						
2004-30	PEBB	230	N BARTOW	230	1	2						
2004-30	RECKER	230	LKAGNES	230	1	16						
2004-30	RECKER	230	ARIANA	230	1	16						
2004-30	RECKER	230	CREWSLK	230	1	13						
2004-30	B BEND	230	MANATEE	230	1	1						
2004-30	RUSKIN T	230	MANATEE	230	1	1						
2004-30	IND RIV	230	IND RIV	115	1	11						
2004-30	SHELD	230	SHELD-NW	69	1	16						
2004-30	LARGO	230	LARGO A	69	1	2						
2004-30	CLMT EST	230	CLMT EST	69	1	2						
2004-30	11TH AVE	230	ELEVEN-E	69	1	16						
2004-30	WINDERME	230	WINDERME	69	1	2						
2004-30	PASADENA	230	PASADENA	115	1	2						
2004-30	ARIANA	230	ARIANA-N	69	1	16						
2004-30	SELOSE	230	SELOSE-N	69	1	16						
2004-30	GAPWAY	230	GAPWAY	69	1	16						
2004-30	CREWSLK	230	CREWSLK	69	1	13						
2004-30	TENOROC	230	TENOROC	69	1	13						
2004-30	BARCOLA	230	WEST	230	1	2						
2004-30	EATON PK	230	CREWSLK	230	1	13						
2004-30	EATON PK	230	EATON PK	69	1	13						
2004-30	EATON PK	230	TENOROC	230	1	13						
2004-30	RECKER	230	GAPWAY	230	1	16						
2004-30	SN PLANT	115	TURNER	115	1	1						
2004-31	SN PLANT	230	SYLVAN	230	1	1						
2004-31	SYLVAN	230	N LONGWD	230	1	1						
2004-31	IND RIV	230	STANTON	230	1	11						
2004-31	SN PLANT	115	TURNER	115	1	1						
2004-31	BUCKEYE	230	RUSKMTR8	230	1	1						
2004-31	SILVR SP	230	SILV SPN	230	1	2						
2004-31	SILVR SP	230	OCALA 1	230	1	2						
2004-31	RIO PINR	230	CURRY FD	230	1	2						
2004-31	STANTON	230	CURRY FD	230	1	2						
2004-31	OSCEOLA	230	LKAGNES	230	1	16						
2004-31	SHELD	230	LK TARP	230	1	2						
2004-31	PEBB	230	CREWSLK	230	1	13						
2004-31	PEBB	230	N BARTOW	230	1	2						
2004-31	RECKER	230	LKAGNES	230	1	16						
2004-31	RECKER	230	ARIANA	230	1	16						
2004-31	RECKER	230	CREWSLK	230	1	13						
2004-31	B BEND	230	MANATEE	230	1	1						
2004-31	RUSKIN T	230	MANATEE	230	1	1						
2004-31	IND RIV	230	IND RIV	115	1	11						
2004-31	SHELD	230	SHELD-NW	69	1	16						
2004-31	LARGO	230	LARGO A	69	1	2						
2004-31	CLMT EST	230	CLMT EST	69	1	2						
2004-31	11TH AVE	230	ELEVEN-E	69	1	16						
2004-31	WINDERME	230	WINDERME	69	1	2						
2004-31	PASADENA	230	PASADENA	115	1	2						
2004-31	ARIANA	230	ARIANA-N	69	1	16						
2004-31	SELOSE	230	SELOSE-N	69	1	16						
2004-31	GAPWAY	230	GAPWAY	69	1	16						
2004-31	CREWSLK	230	CREWSLK	69	1	13						
2004-31	TENOROC	230	TENOROC	69	1	13						
2004-31	BARCOLA	230	WEST	230	1	2						
2004-31	EATON PK	230	CREWSLK	230	1	13						
2004-31	EATON PK	230	EATON PK	69	1	13						
2004-31	EATON PK	230	TENOROC	230	1	13						
2004-31	RECKER	230	GAPWAY	230	1	16						
2004-31	SN PLANT	115	TURNER	115	1	1						

Table I
Comparison of Line & Transformer Flows
Following N-1 Disturbances
for Various OEC 500 MW Generation Alternatives

100% Load Base Case

All Flows above 100% of Emergency rating are Shown

Monitored Branches							Case 2004 Base No OEC Gen	Case 2004A Sell to FPL	Case 2004B Sell to FPC	Case 2004C Sell to TEC	Case 2004D Sell to JEA	Case 2004E Sell to SEM
Case	Bus 1	kV 1	Bus 2	kV 2	ckt	Area	Percent	Percent	Percent	Percent	Percent	Percent
2004-32	SN PLANT	230	SYLVAN	230	1	1						
2004-32	SYLVAN	230	N LONGWD	230	1	1						
2004-32	IND RIV	230	STANTON	230	1	11						
2004-32	SN PLANT	115	TURNER	115	1	1						
2004-32	BUCKEYE	230	RUSKMTR8	230	1	1						
2004-32	SILVR SP	230	SILV SPN	230	1	2						
2004-32	SILVR SP	230	OCALA 1	230	1	2						
2004-32	RIO PINR	230	CURRY FD	230	1	2						
2004-32	STANTON	230	CURRY FD	230	1	2						
2004-32	OSCEOLA	230	LKAGNES	230	1	16						
2004-32	SHELD	230	LK TARPEN	230	1	2						
2004-32	PEBB	230	CREWSLK	230	1	13						
2004-32	PEBB	230	N BARTOW	230	1	2						
2004-32	RECKER	230	LKAGNES	230	1	16						
2004-32	RECKER	230	ARIANA	230	1	16						
2004-32	RECKER	230	CREWSLK	230	1	13						
2004-32	B BEND	230	MANATEE	230	1	1						
2004-32	RUSKIN T	230	MANATEE	230	1	1						
2004-32	IND RIV	230	IND RIV	115	1	11						
2004-32	SHELD	230	SHELD-NW	69	1	16						
2004-32	LARGO	230	LARGO A	69	1	2						
2004-32	CLMT EST	230	CLMT EST	69	1	2						
2004-32	11TH AVE	230	ELEVEN-E	69	1	16						
2004-32	WINDERME	230	WINDERME	69	1	2						
2004-32	PASADENA	230	PASADENA	115	1	2						
2004-32	ARIANA	230	ARIANA-N	69	1	16						
2004-32	SELOSE	230	SELOSE-N	69	1	16						
2004-32	GAPWAY	230	GAPWAY	69	1	16						
2004-32	CREWSLK	230	CREWSLK	69	1	13						
2004-32	TENOROC	230	TENOROC	69	1	13						
2004-32	BARCOLA	230	WEST	230	1	2						
2004-32	EATON PK	230	CREWSLK	230	1	13						
2004-32	EATON PK	230	EATON PK	69	1	13						
2004-32	EATON PK	230	TENOROC	230	1	13						
2004-32	RECKER	230	GAPWAY	230	1	16						
2004-32	SN PLANT	115	TURNER	115	1	1						
2004-33	SN PLANT	230	SYLVAN	230	1	1						
2004-33	SYLVAN	230	N LONGWD	230	1	1						
2004-33	IND RIV	230	STANTON	230	1	11						
2004-33	SN PLANT	115	TURNER	115	1	1						
2004-33	BUCKEYE	230	RUSKMTR8	230	1	1						
2004-33	SILVR SP	230	SILV SPN	230	1	2						
2004-33	SILVR SP	230	OCALA 1	230	1	2						
2004-33	RIO PINR	230	CURRY FD	230	1	2						
2004-33	STANTON	230	CURRY FD	230	1	2						
2004-33	OSCEOLA	230	LKAGNES	230	1	16						
2004-33	SHELD	230	LK TARPEN	230	1	2						
2004-33	PEBB	230	CREWSLK	230	1	13						
2004-33	PEBB	230	N BARTOW	230	1	2						
2004-33	RECKER	230	LKAGNES	230	1	16						
2004-33	RECKER	230	ARIANA	230	1	16						
2004-33	RECKER	230	CREWSLK	230	1	13						
2004-33	B BEND	230	MANATEE	230	1	1						
2004-33	RUSKIN T	230	MANATEE	230	1	1						
2004-33	IND RIV	230	IND RIV	115	1	11						
2004-33	SHELD	230	SHELD-NW	69	1	16						
2004-33	LARGO	230	LARGO A	69	1	2						
2004-33	CLMT EST	230	CLMT EST	69	1	2						
2004-33	11TH AVE	230	ELEVEN-E	69	1	16						
2004-33	WINDERME	230	WINDERME	69	1	2						
2004-33	PASADENA	230	PASADENA	115	1	2						
2004-33	ARIANA	230	ARIANA-N	69	1	16						
2004-33	SELOSE	230	SELOSE-N	69	1	16						
2004-33	GAPWAY	230	GAPWAY	69	1	16						
2004-33	CREWSLK	230	CREWSLK	69	1	13						
2004-33	TENOROC	230	TENOROC	69	1	13						
2004-33	BARCOLA	230	WEST	230	1	2						
2004-33	EATON PK	230	CREWSLK	230	1	13						
2004-33	EATON PK	230	EATON PK	69	1	13						
2004-33	EATON PK	230	TENOROC	230	1	13						
2004-33	RECKER	230	GAPWAY	230	1	16						
2004-33	SN PLANT	115	TURNER	115	1	1						

Table I
Comparison of Line & Transformer Flows
Following N-1 Disturbances
for Various OEC 500 MW Generation Alternatives

100% Load Base Case

All Flows above 100% of Emergency rating are Shown

Monitored Branches							Case 2004 Base No OEC Gen	Case 2004A Sell to FPL	Case 2004B Sell to FPC	Case 2004C Sell to TEC	Case 2004D Sell to JEA	Case 2004E Sell to SEM
Case	Bus 1	kV 1	Bus 2	kV 2	ckt	Area	Percent	Percent	Percent	Percent	Percent	Percent
2004-34	SN PLANT	230	SYLVAN	230	1	1						
2004-34	SYLVAN	230	N LONGWD	230	1	1						
2004-34	IND RIV	230	STANTON	230	1	11						
2004-34	SN PLANT	115	TURNER	115	1	1						
2004-34	BUCKEYE	230	RUSKMTRB	230	1	1						
2004-34	SILVR SP	230	SILV SPN	230	1	2						
2004-34	SILVR SP	230	OCALA 1	230	1	2						
2004-34	RIO PINR	230	CURRY FD	230	1	2						
2004-34	STANTON	230	CURRY FD	230	1	2						
2004-34	OSCEOLA	230	LKAGNES	230	1	16						
2004-34	SHELD	230	LK TARP	230	1	2						
2004-34	PEBB	230	CREWSLK	230	1	13						
2004-34	PEBB	230	N BARTOW	230	1	2						
2004-34	RECKER	230	LKAGNES	230	1	16						
2004-34	RECKER	230	ARIANA	230	1	16						
2004-34	RECKER	230	CREWSLK	230	1	13						
2004-34	B BEND	230	MANATEE	230	1	1						
2004-34	RUSKIN T	230	MANATEE	230	1	1						
2004-34	IND RIV	230	IND RIV	115	1	11						
2004-34	SHELD	230	SHELD-NW	69	1	16						
2004-34	LARGO	230	LARGO A	69	1	2						
2004-34	CLMT EST	230	CLMT EST	69	1	2						
2004-34	11TH AVE	230	ELEVEN-E	69	1	16						
2004-34	WINDERME	230	WINDERME	69	1	2						
2004-34	PASADENA	230	PASADENA	115	1	2						
2004-34	ARIANA	230	ARIANA-N	69	1	16						
2004-34	SELOSE	230	SELOSE-N	69	1	16						
2004-34	GAPWAY	230	GAPWAY	69	1	16						
2004-34	CREWSLK	230	CREWSLK	69	1	13						
2004-34	TENOROC	230	TENOROC	69	1	13						
2004-34	BARCOLA	230	WEST	230	1	2						
2004-34	EATON PK	230	CREWSLK	230	1	13						
2004-34	EATON PK	230	EATON PK	69	1	13						
2004-34	EATON PK	230	TENOROC	230	1	13						
2004-34	RECKER	230	GAPWAY	230	1	16						
2004-34	SN PLANT	115	TURNER	115	1	1						
2004-35	SN PLANT	230	SYLVAN	230	1	1						
2004-35	SYLVAN	230	N LONGWD	230	1	1						
2004-35	IND RIV	230	STANTON	230	1	11						
2004-35	SN PLANT	115	TURNER	115	1	1						
2004-35	BUCKEYE	230	RUSKMTRB	230	1	1						
2004-35	SILVR SP	230	SILV SPN	230	1	2						
2004-35	SILVR SP	230	OCALA 1	230	1	2						
2004-35	RIO PINR	230	CURRY FD	230	1	2						
2004-35	STANTON	230	CURRY FD	230	1	2						
2004-35	OSCEOLA	230	LKAGNES	230	1	16						
2004-35	SHELD	230	LK TARP	230	1	2						
2004-35	PEBB	230	CREWSLK	230	1	13						
2004-35	PEBB	230	N BARTOW	230	1	2						
2004-35	RECKER	230	LKAGNES	230	1	16						
2004-35	RECKER	230	ARIANA	230	1	16						
2004-35	RECKER	230	CREWSLK	230	1	13						
2004-35	B BEND	230	MANATEE	230	1	1						
2004-35	RUSKIN T	230	MANATEE	230	1	1						
2004-35	IND RIV	230	IND RIV	115	1	11						
2004-35	SHELD	230	SHELD-NW	69	1	16						
2004-35	LARGO	230	LARGO A	69	1	2						
2004-35	CLMT EST	230	CLMT EST	69	1	2						
2004-35	11TH AVE	230	ELEVEN-E	69	1	16						
2004-35	WINDERME	230	WINDERME	69	1	2						
2004-35	PASADENA	230	PASADENA	115	1	2						
2004-35	ARIANA	230	ARIANA-N	69	1	16						
2004-35	SELOSE	230	SELOSE-N	69	1	16						
2004-35	GAPWAY	230	GAPWAY	69	1	16						
2004-35	CREWSLK	230	CREWSLK	69	1	13						
2004-35	TENOROC	230	TENOROC	69	1	13						
2004-35	BARCOLA	230	WEST	230	1	2						
2004-35	EATON PK	230	CREWSLK	230	1	13						
2004-35	EATON PK	230	EATON PK	69	1	13						
2004-35	EATON PK	230	TENOROC	230	1	13						
2004-35	RECKER	230	GAPWAY	230	1	16						
2004-35	SN PLANT	115	TURNER	115	1	1						

APPENDIX II-A

RECKER
9100

←73.5

←20.2

←57.0

→26.9

←104.3

←7.0

→40.4

←8.3

→109.2

←15.9

1

→21.5

←24.5

235.6
1.025

CREWSLK
6105

237.1
1.031

→82.0

←7.6

→8

←1.025

6045

←1.025

CREWSLK
70.73

→36.6

←15.0

→15.0

←1.029

6103

←1.029

EATON PK
236.8

→130.7

←44.0

→130.7

←1.038

9050

←1.038

PEBB
238.8

1.085

APP-CT
7961

14.04

←1.017

APP-ST
7962

13.96

←1.012

ARIANA
9110

235.6
1.024

→104.3

←7.3

→104.3

←1.018

9102

←1.018

ARIANA-N
70.22

LXAGNES
9150

235.2
1.027

→266.3

←3.8

→266.3

←1.032

6101

←1.032

MCINTOSH
237.4

→323.2

←20.0

→323.2

←1.025

7890

←1.025

OSCEOLA
235.8

GAPWAY
9160

235.2
1.023

→73.4

←21.2

→73.4

←1.022

9162

←1.022

GAPWAY
70.50

2004. sav

P mis = 0.0002 MW

Q mis = -0.0010 MVAR

General Electric Company

PSLF Program



GENERAL
ELECTRIC
COMPANY

FERC 2004 SUMMER BASE CASE - FY1998 - REVISION 5
PROPOSED OSPREY ENERGY CENTER

HW/MAR

Fri Feb 26 10:09:55 2000

2004. sav
Rating = 1

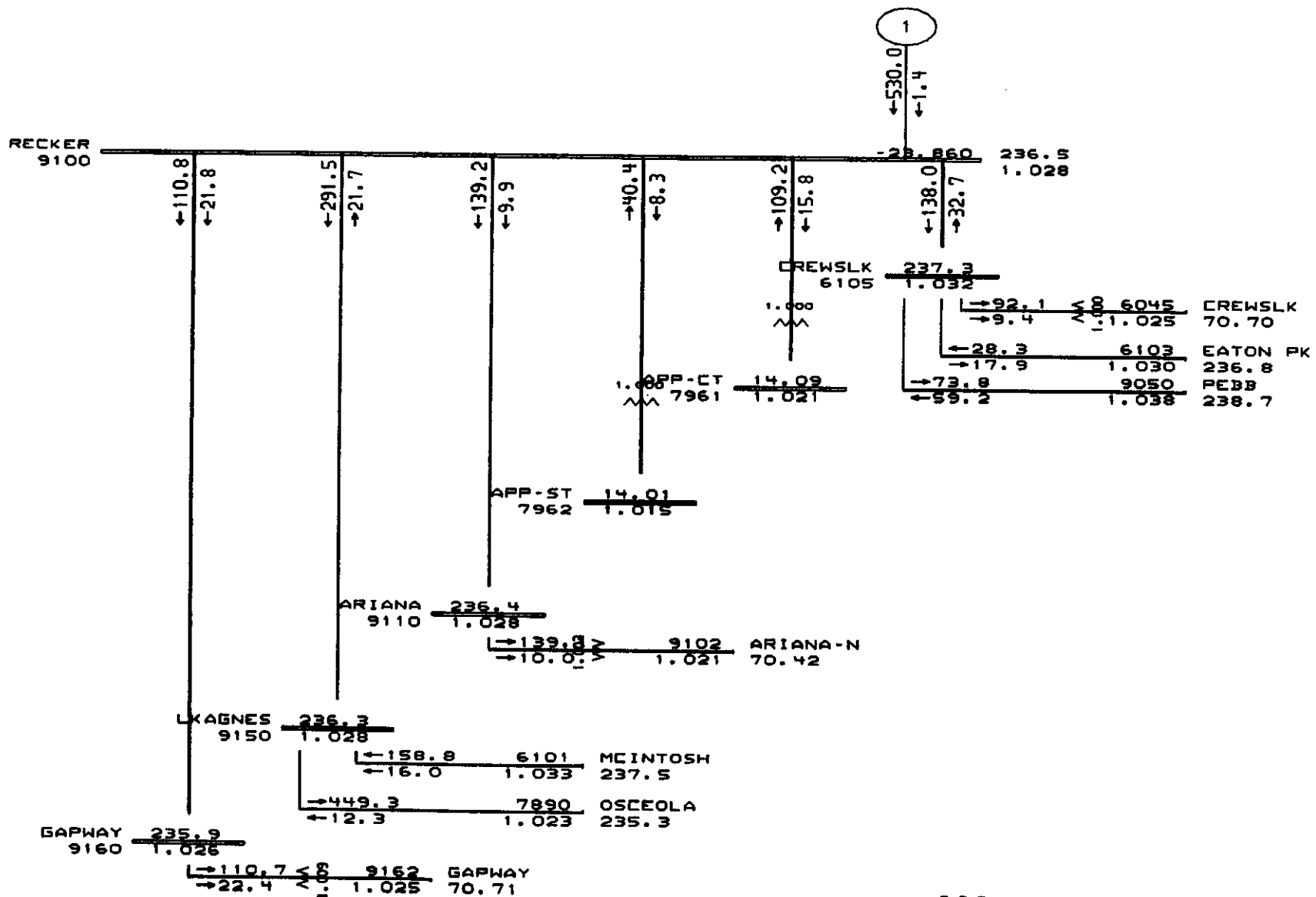

2004a.sav
 P mis = -0.0023 MW
 Q mis = -0.0005 MVAR



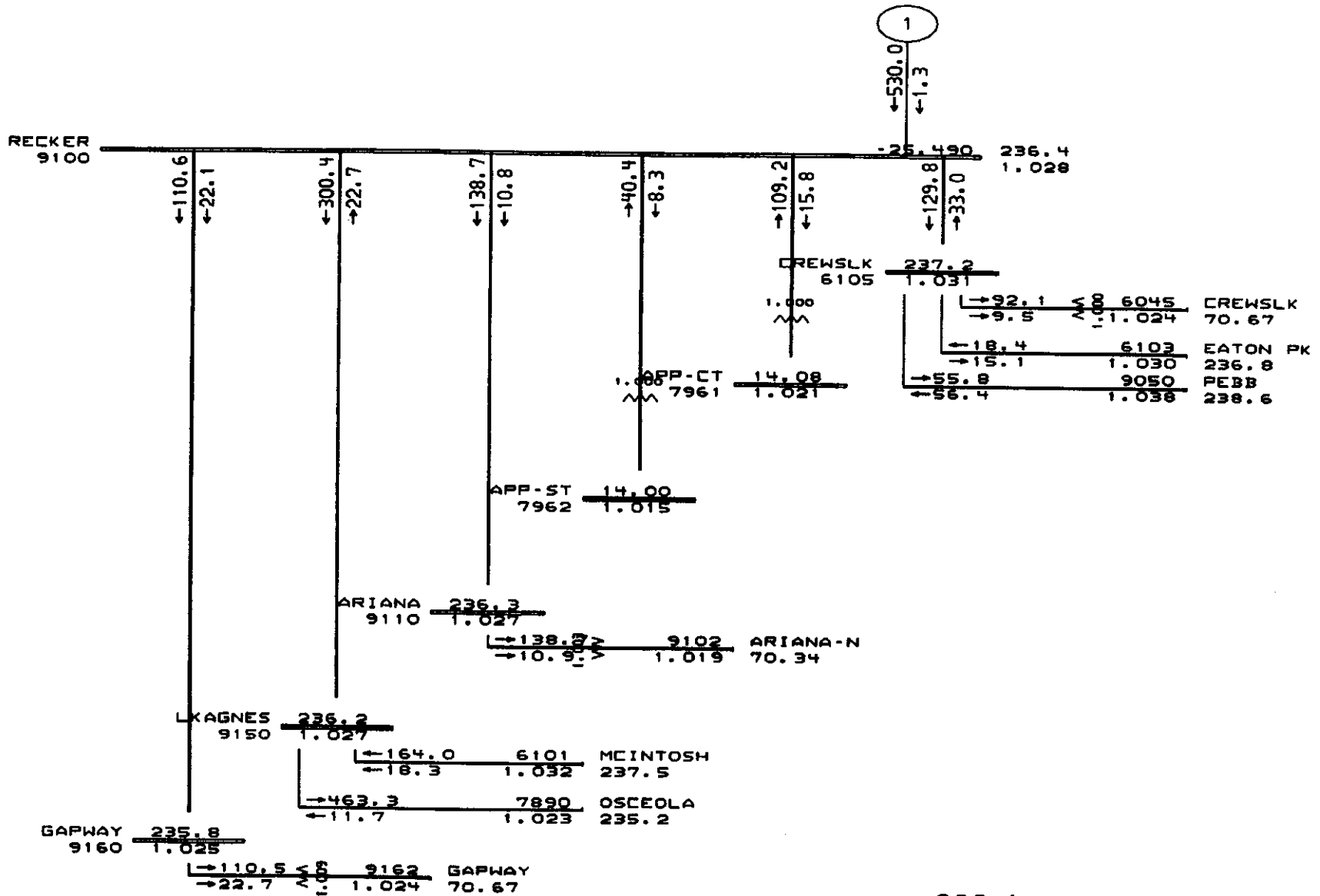

2004b.sav
 P mis = -0.0002 MW
 Q mis = 0.0027 MVAR



RECKER
9100

←111.7

←21.4

←271.6

→24.1

←139.5

←9.2

→40.4

←8.3

→109.2

←15.8

←530.0
←0.6

236.5
1.028

←156.7
→30.0

CREWSLK
6105

237.1
1.031

→93.8
→10.1

6045
1.023

CREWSLK
70.61

→41.2
→15.8

6103
1.029

EATON PK
236.7

→103.6
→156.1

9050
1.036

FEBB
238.4

APP-CT
7961

14.09
1.021

APP-ST
7962

14.01
1.015

ARIANA
9110

236.4
1.028

→139.8
→9.4

9102
1.021

ARIANA-N
70.45

LXAGNES
9150

236.5
1.028

←135.5
←15.6

6101
1.033

MCINTOSH
237.5

→406.2
←13.7

7890
1.024

OSCEOLA
235.5

GAPWAY
9160

236.0
1.026

→111.6
→22.0

9162
1.025

GAPWAY
70.73

2004c.sav

P mis = -0.0010 MW

Q mis = -0.0011 MVAR



RECKER
9100

←110.6

←21.7

←298.8

→21.8

←138.7

←9.8

→40.4

←8.3

→109.2

←15.8

1
←530.0
←0.8

←21.066

236.4
1.028

←131.4

→33.0

CREWSLK
6105

237.2
1.031

→92.0
→9.3

6045
1.025

CREWSLK
70.70

→20.1
→16.8

6103
1.030

EATON PK
236.8

→59.2
→58.0

9050
1.038

PEBB
238.7

APP-CT
7961

14.09
1.021

APP-ST
7962

14.01
1.015

ARIANA
9110

236.3
1.028

→138.0
→10.0

9102
1.020

ARIANA-N
70.40

LXAGNES
9150

236.3
1.027

←162.8
←17.1

6101
1.032

MCINTOSH
237.5

→460.5
←11.9

7890
1.023

OSCEOLA
235.3

GAPWAY
9160

235.9
1.026

→110.5
→22.3

9162
1.025

GAPWAY
70.70

2004d.sav

P mis = 0.0001 MW

Q mis = -0.0001 MVAR



RECKER
9100

←79.6
→21.3

←133.2
←17.5

→40.4
←8.3

→109.2
←15.8

1

236.1
1.026

CREWSLK
6105

237.2
1.031

→85.9
→8.2

6045
1.025

CREWSLK
70.74

←28.5
←17.0

6103
1.030

EATON PK
236.8

←120.7
←41.8

9050
1.038

PEBB
238.8

APP-CT
7961

14.06
1.019

APP-ST
7962

13.99
1.013

ARIANA
9110

235.9
1.026

→133.8
→17.7

9102
1.014

ARIANA-N
69.97

LKAGNES
9150

236.4
1.028

←248.0
←0.6

6101
1.032

MCINTOSH
237.5

←327.5
←17.9

7890
1.025

OSEEOLA
235.8

GAPWAY
9160

229.8
0.999

→0.0
→0.0

9162
1.008

GAPWAY
69.55

2004.sav

P mis = 0.0002 MW

Q mis = -0.0010 MVAR

General Electric Company

PSLF Program

FERC 2004 SUMMER BASE CASE - FY1998 - REVISION 5
PROPOSED OSPREY ENERGY CENTER

MM/TRANS

Wed Feb 16 14:51:42 2000



GENERAL
ELECTRIC
COMPANY

2004.sav
Rating = 1

RECKER
9100

←81.1
←16.4

←109.7
←4.6

→40.4
←8.4

→109.2
←16.0

→30.797
234.7
1.020

CREWSLK
6105
236.8
1.030

→83.4	6045	CREWSLK	70.68
→6.9	1.024		
→8.3	6103	EATON PK	236.7
→5.0	1.029		
→116.4	9050	PEBB	238.8
→53.4	1.038		

1.006 APP-CT 7961 13.98 1.013

APP-ST 7962 13.90 1.007

ARIANA 9110 234.6 1.020

→109.07
→4.8
1.015 9102 ARIANA-N 70.03

LKAGNES 9150 236.6 1.029

→311.8
→16.1
1.032 6101 MCINTOSH 237.5

→311.8
→16.1
1.026 7890 OSCEOLA 235.9

GAPWAY 9160 234.2 1.018

→81.0
→17.4
1.019 9162 GAPWAY 70.34

2004.sav
P mis = 0.0002 MW
Q mis = -0.0010 MVAR

General Electric Company

PSLF Program



GENERAL
ELECTRIC
COMPANY

FERC 2004 SUMMER BASE CASE - FY1998 - REVISION 5
PROPOSED OSPREY ENERGY CENTER

MW/MVAR

Wed Feb 16 15:13:18 2000

2004.sav
Rating = 1

RECKER
9100

←121.1

←29.9

←83.8

→27.7

→40.4

←8.3

→109.2

←15.9

1

-31.174

235.7
1.025

CREWSLK
6105

237.1
1.031

→88.1

→8.0

→1.000

→1.025

6045

CREWSLK
70.72

←33.1

←15.0

←1.029

6103

EATON PK
236.8

←110.4

←45.8

←1.038

9050

FE3B
238.8

APP-CT
7961

14.04
1.018

APP-ST
7962

13.96
1.012

ARIANA
9110

231.0
1.004

→0.0

→0.0

9102
1.001

ARIANA-N
69.10

LKAGNES
9150

236.2
1.027

→246.8

→5.7

6101
1.032

MCINTOSH
237.5

→330.5

→19.4

7890
1.025

OSCEOLA
235.7

GAPWAY
9160

235.0
1.022

→121.0

→30.3

9162
1.018

GAPWAY
70.21

2004.sav

P mis = 0.0002 MW

Q mis = -0.0010 MVAR

General Electric Company

PLF Program

PLF/PLM

Rev Feb 16 15:15:07 2000



GENERAL
ELECTRIC
COMPANY

FERC 2004 SUMMER BASE CASE - FY1998 - REVISION 5
PROPOSED OSPREY ENERGY CENTER

2004.sav
Rating = 1

RECKER
9100

←61.8
←16.7

→6.7
→45.4

←94.4
←4.4

→40.4
→8.4

→109.2
→16.0

1

-32.453 234.2
1.018

CREWSLK
6105 237.7
1.033

→88.1
→9.6

←1.000
←1.026

6045 CREWSLK
70.79

→9.7
→22.7

←1.031

6103 EATON PK
237.0

←97.8
←32.3

←1.039

9050 PE3B
238.9

APP-CT 13.95
7961 1.011

APP-ST 13.87
7962 1.005

ARIANA 234.2
9110 1.018

→94.4
→4.7

9102 ARIANA-N
69.89
1.013

LKAGNES 235.5
9150 1.024

←316.7
←15.4

6101 MCINTOSH
237.4
1.032

→310.0
→26.8

7890 OSCEOLA
235.6
1.024

GAPWAY 233.9
9160 1.017

→61.8
→17.8

←1.008
←1.017

9162 GAPWAY
70.20

2004.sav
P mis = 0.0002 MW
Q mis = -0.0010 MVAR

General Electric Company

PLP Program

M/MVAR

Ms4 Feb 16 15:15:29 2000



FERC 2004 SUMMER BASE CASE - FY1998 - REVISION 5
PROPOSED OSPREY ENERGY CENTER

2004.sav
Rating = 1

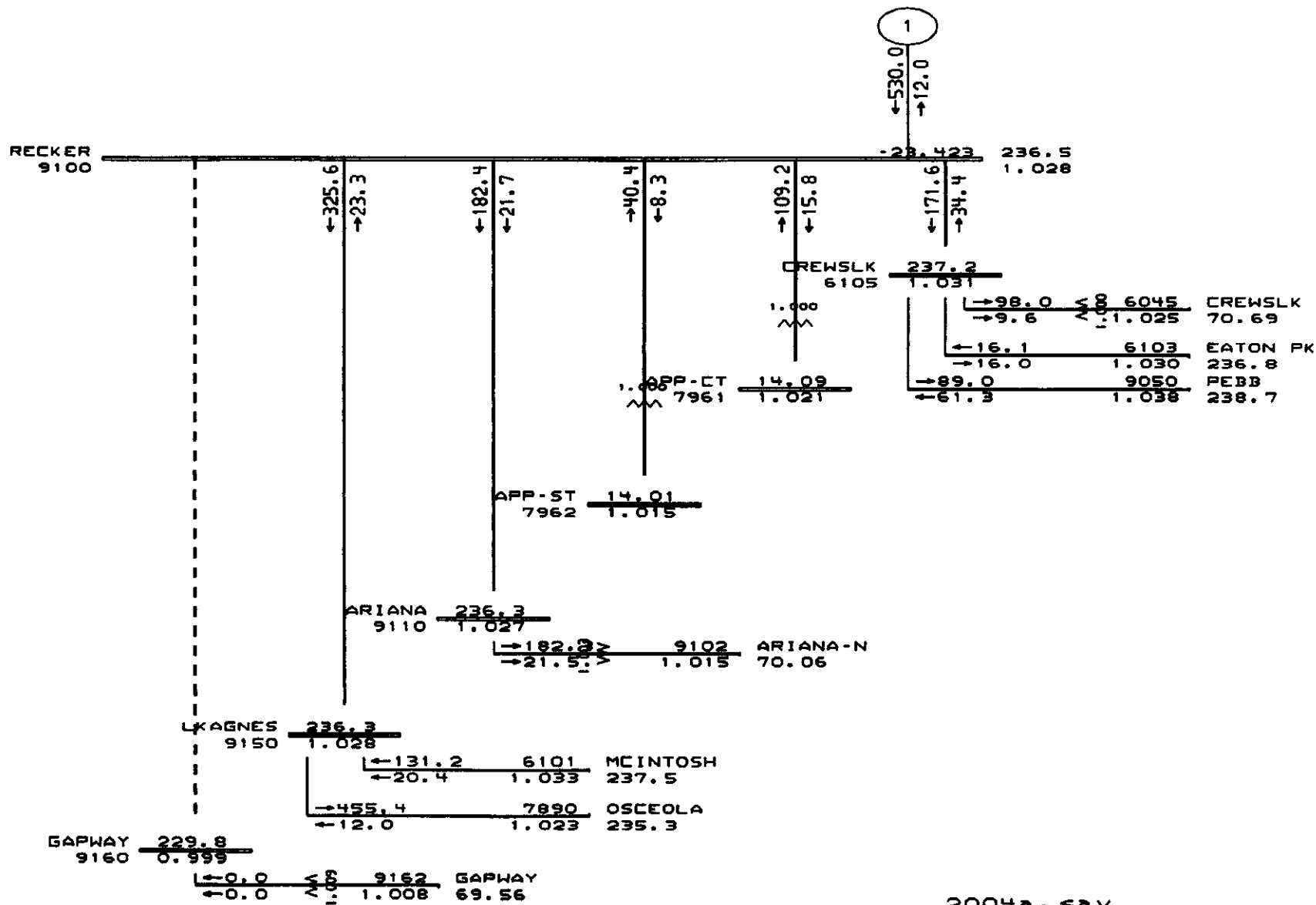

2004a.sav
P mis = -0.0023 MW
Q mis = -0.0005 MVAR



RECKER
9100

←150.9
←21.3

←168.6
←11.0

→40.4
←8.3

→109.2
←15.8

←530.0
←14.1

←20.4
←91
236.5
1.028

CREWSLK
6105

237.1
1.031

→99.0
→9.7
→114.2
→2.0
→144.2
→70.2

6045
1.024
6103
1.030
9050
1.038

CREWSLK
70.65
EATON PK
236.8
FE33
238.7

APP-CT
7961

14.09
1.021

APP-ST
7962

14.01
1.015

ARIANA
9110

236.4
1.028

→168.8
→11.0
9102
1.021

ARIANA-N
70.44

LKAGNES
9150

236.2
1.027

→389.2
→17.5
6101
1.032

MCINTOSH
237.4

→389.2
→17.5
7890
1.024

OSCEOLA
235.5

GAPWAY
9160

235.9
1.025

→150.7
→21.2
9162
1.026

GAPWAY
70.76

2004a. sav
P mis = -0.0023 MW
Q mis = -0.0005 MVAR



RECKER
9100

←174.0
←35.1

←327.4
→23.0

→40.4
←8.3

→109.2
←15.8

←530.0
←1.5

236.5
1.028

CREWSLK
6105

237.2
1.031

→100.2
→9.7

6045
1.024

CREWSLK
70.69

→23.7
→16.4

6103
1.030

EATON PK
236.8

→100.9
→62.3

9050
1.038

PEBB
238.7

1.000
APP-CT
7961

14.09
1.021

APP-ST
7962

14.01
1.015

ARIANA
9110

230.8
1.004

←0.0
←0.0

1.003
9102
1.001

ARIANA-N
69.06

LKAGNES
9150

236.3
1.027

←132.8
←20.5

6101
1.033

MCINTOSH
237.5

→458.9
→11.8

7890
1.023

OSCEOLA
235.3

GAPWAY
9160

235.6
1.024

→173.7
→34.5

9162
1.019

GAPWAY
70.32

2004a. sav

P mis = -0.0023 MW

Q mis = -0.0005 MVAR

General Electric Company

PSLF Program

FERC 2004 SUMMER BASE CASE - FY1998 - REVISION 5
PROPOSED OSPREY ENERGY CENTER

MM/THAN

Wed Feb 16 14:52:22 2000



GENERAL
ELECTRIC
COMPANY

2004a. sav
Rating = 1

RECKER
9100

←129.3

←21.2

←395.7

→25.6

←154.5

←10.0

→40.4

←8.3

→109.2

←15.8

1

←530.0

←29.7

←22.660

236.5
1.028

CREWSLK
6105

237.6
1.033

1.000

→82.7

→10.5

6045
1.025

CREWSLK
70.70

APP-CT
7961

14.09
1.021

←103.3

→34.8

6103
1.030

EATON PK
236.9

→20.5

→45.3

9050
1.038

PEBB
236.8

APP-ST
7962

14.01
1.015

ARIANA
9110

236.4
1.028

→154.8

→10.1

9102
1.021

ARIANA-N
70.45

LKAGNES
9150

236.3
1.027

←75.6

←29.5

6101
1.033

MCINTOSH
237.5

→469.4

←11.3

7890
1.023

OSCEOLA
235.2

GAPWAY
9160

235.9
1.026

→129.2

→21.6

9162
1.025

GAPWAY
70.74

2004a, sav

P mis = -0.0023 MW

Q mis = -0.0005 MVAR

General Electric Company

PSLF Program

FERC 2004 SUMMER BASE CASE - FY1998 - REVISION 5
PROPOSED OSPREY ENERGY CENTER

HM/TRMR

Wed Feb 16 14:52:40 2000



GENERAL
ELECTRIC
COMPANY

2004a.sav
Rating = 1

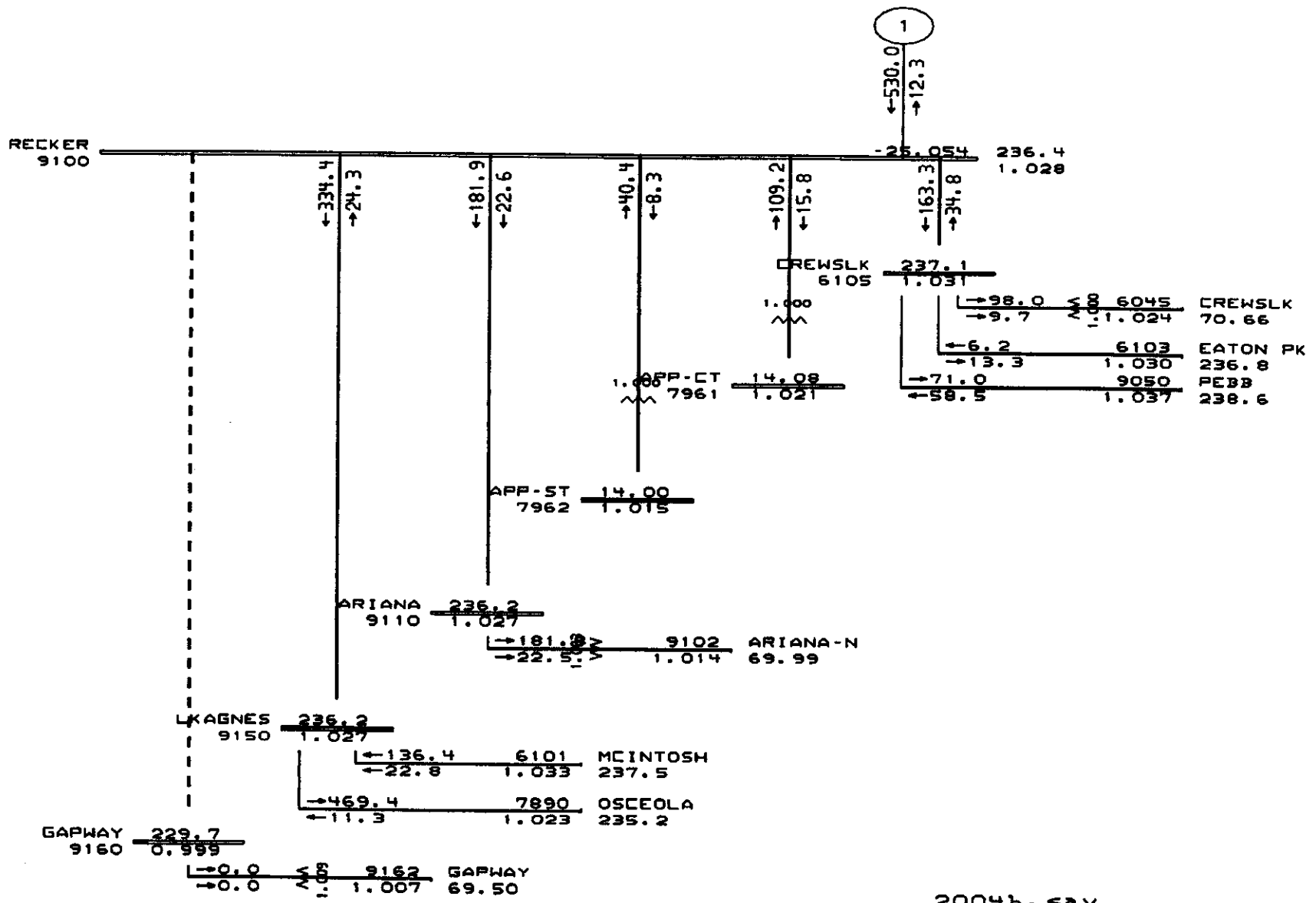

2004b.sav
 P mis = -0.0002 MW
 Q mis = 0.0027 MVAR



RECKER
9100

←151.9
←21.6

←168.9
←12.0

→40.4
←8.3

→109.2
←15.8

←530.0
←14.6

←22.0
←358.7
←43.0
236.4
1.028

CREWSLK
6105

237.0
1.030

→99.2
→9.8
→128.0
→5.0
→128.8
→67.9

6045
1.023

CREWSLK
70.62

EATON PK
236.9

6103
1.030

9050
1.037

PEBB
238.6

APP-CT
7961

14.08
1.021

APP-ST
7962

14.00
1.015

ARIANA
9110

236.2
1.027

→168.8
→12.0

9102
1.020

ARIANA-N
70.37

LXAGNES
9150

235.1
1.027

←400.8
→17.2

6101
1.032

MCINTOSH
237.4

→400.8
←17.2

7890
1.024

OSCEOLA
235.5

GARWAY
9160

235.7
1.025

→151.7
→21.5

9162
1.025

GARWAY
70.72

2004b.sav

P mis = -0.0002 MW

Q mis = 0.0027 MVAR

General Electric Company

PS/P Program

FERC 2004 SUMMER BASE CASE - FY1998 - REVISION 5
PROPOSED OSPREY ENERGY CENTER

MM/MMR

Wed Feb 16 19:53:14 2000



GENERAL
ELECTRIC
COMPANY

2004b.sav
Rating = 1

RECKER
9100

←173.6

←35.7

←336.2

→24.0

→40.4

←8.3

→109.2

←15.8

1

←530.0

←0.8

236.4
1.028

CREWSLK
6105

237.1
1.031

1.000
M

→100.2
→9.9

6045
1.024

CREWSLK
70.66

→13.8
→13.6

6103
1.029

EATON PK
236.8

→82.7
→9.5

9050
1.037

REBB
238.6

1.000
M

14.08
1.021

1.000
M

14.00
1.015

ARIANA
9110 230.4
1.002

→40.0
→0.0

9102
0.999

ARIANA-N
68.95

LKAGNES
9150 236.2
1.027

←138.1
←22.9

6101
1.033

MCINTOSH
237.5

→472.9
→11.1

7890
1.022

OSCEOLA
235.2

GAPWAY
9160 235.5
1.024

→173.3
→35.1

9162
1.018

GAPWAY
70.26

2004b.sav

P mis = -0.0002 MW

Q mis = 0.0027 MVAR

General Electric Company

PSLP Program

FERC 2004 SUMMER BASE CASE - FY1998 - REVISION 5
PROPOSED OSPREY ENERGY CENTER

MM/MVAR

Wed Feb 16 14:53:30 2000



GENERAL
ELECTRIC
COMPANY

2004b.sav
Rating = 1

RECKER
9100

←128.0
←21.5

←398.3
→26.3

←153.2
←10.9

→40.4
←8.3

→109.2
←15.8

1
←530.0
←30.2

←25.388 236.4
1.028

CREWSLK
6105 237.5
1.033

→83.3
→10.6

6045
1.1024

CREWSLK
70.68

←89.4
→31.7

6103
1.030

EATON PK
236.9

→6.1
←42.3

9050
1.038

PEBB
238.7

1.000
APP-CT
7961 14.09
1.021

APP-ST
7962 14.00
1.015

ARIANA
9110 236.3
1.027

→153.8
→11.0
9102 ARIANA-N
1.020 70.37

LKAGNES
9150 236.2
1.027

←85.5
←31.1
6101 MCINTOSH
1.032 237.5

→481.9
←10.6
7890 OSCEOLA
1.022 235.1

GAPWAY
9160 235.8
1.025

→127.9
→21.9
9162 GAPWAY
1.025 70.70

2004b.sav
P mis = -0.0002 MW
Q mis = 0.0027 MVAR

General Electric Company



GENERAL
ELECTRIC
COMPANY

PSLF Program

FERC 2004 SUMMER BASE CASE - FY1998 - REVISION 5
PROPOSED OSPREY ENERGY CENTER

104/1000

Wed Feb 16 13:53:47 2000

2004b.sav
Rating = 1

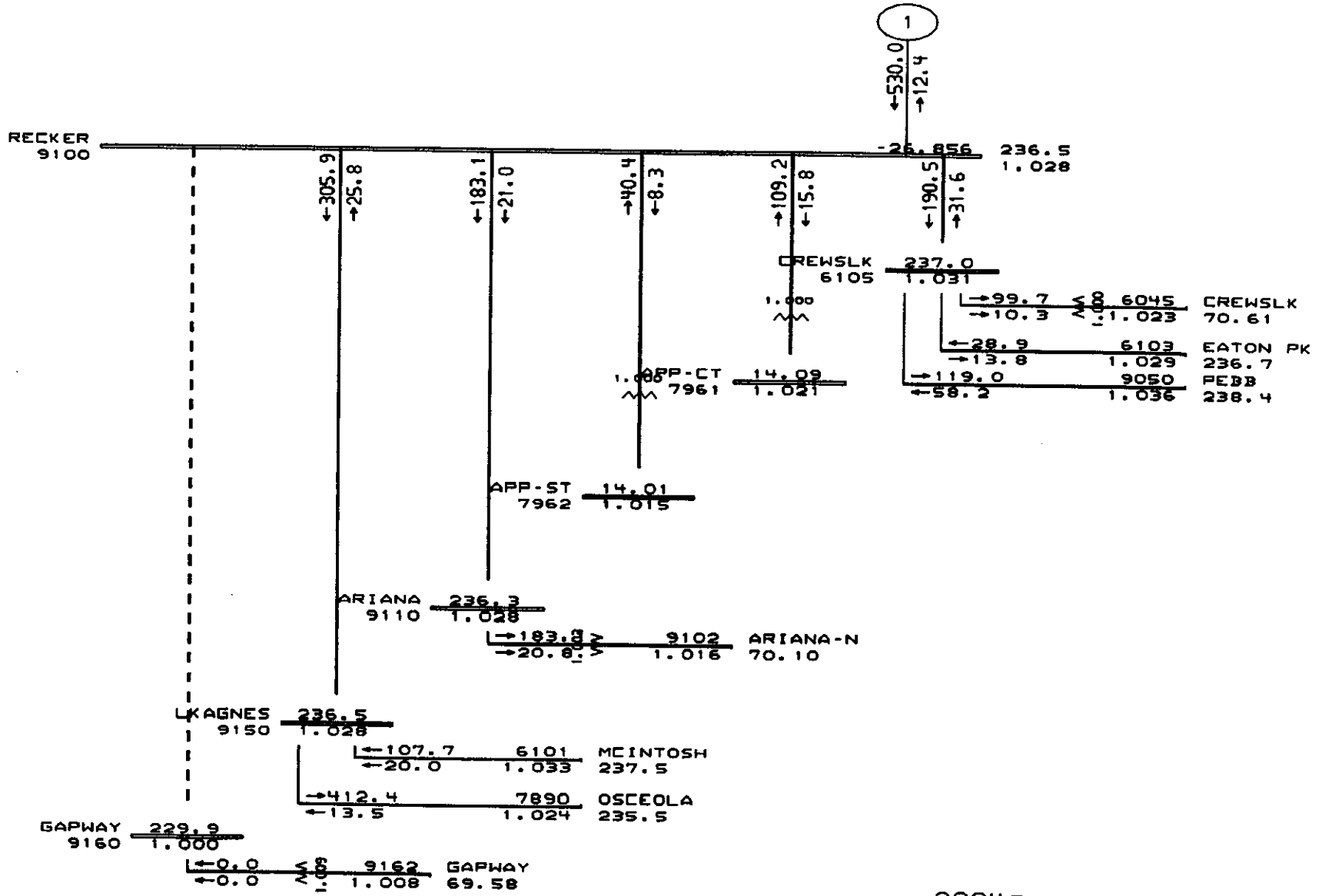

2004c.sav
P mis = -0.0010 MW
Q mis = -0.0011 MVAR



General Electric Company
PSLF Program
FERC 2004 SUMMER BASE CASE - FY1998 - REVISION 5
PROPOSED OSPREY ENERGY CENTER

MM/MVAR Wed Feb 16 19:51:03 2000

2004c.sav
Rating = 1

RECKER
9100

←149.1
←20.9

←167.0
←10.2

→40.4
←8.3

→109.2
←15.8

←530.0
←16.8

236.5
1.028

CREWSLK
6105

236.9
1.030

1.000
ΛΛ

→100.2
→10.3

6045
1.1023
CREWSLK
70.57

1.000
ΛΛ
APP-CT
7961

14.09
1.021

→91.4
→3.2

6103
1.029
EATON PK
236.8

→169.1
→66.2

9050
1.036
REBB
238.3

APP-ST
7962

14.01
1.015

ARIANA
9110

236.4
1.028

→166.5
→10.2

9102
1.021
ARIANA-N
70.48

LKABNES
9150

236.4
1.028

←350.5
→16.9

6101
1.032
MCINTOSH
237.5

→350.5
←16.9

7890
1.025
OSCEOLA
235.7

GAPWAY
9160

235.9
1.026

→148.9
→20.9

9162
1.026
GAPWAY
70.78

2004c.sav
P mis = -0.0010 MW
Q mis = -0.0011 MVAR



PSLF Program
FERC 2004 SUMMER BASE CASE - FY1998 - REVISION 5
PROPOSED OSPREY ENERGY CENTER

RM/THAM Wed Feb 16 14:54:17 2000

2004c.sav
Rating = 1

RECKER
9100

←175.1
←34.5

←307.6
→25.6

→40.4
←8.3

→109.2
←15.8

←530.0
←1.3

236.5
1.028

CREWSLK
6105

237.0
1.031

1.000

→101.9
→10.4

6045
1.023

CREWSLK
70.61

APP-CT
7961

14.09
1.021

→36.6
→14.2
→130.7
→59.2

6103
9050
1.029
1.036

EATON PK
236.7
PEBB
238.3

APP-ST
7962

14.01
1.015

ARIANA
9110

231.0
1.004

→0.0
→0.0

1.003
9102
1.002

ARIANA-N
69.11

LKAGNES
9150

236.5
1.028

←109.5
←20.1

6101
1.033

MCINTOSH
237.5

←415.9
←13.3

7890
1.024

OSCEOLA
235.5

GAPWAY
9160

235.6
1.024

→174.8
→34.0

1.008
9162
1.019

GAPWAY
70.34

2004c. sav
P mis = -0.0010 MW
Q mis = -0.0011 MVAR

General Electric Company

PSLF Program



GENERAL
ELECTRIC
COMPANY

FERC 2004 SUMMER BASE CASE - FY1998 - REVISION 5
PROPOSED OSPREY ENERGY CENTER

184/MVAR

Wed Feb 16 14:59:21 2000

2004c. sav
Rating = 1

RECKER
9100

←132.8

←20.9

←389.8

→28.9

←157.0

←9.5

→40.4

←8.3

→109.2

←15.8

1

←530.0

←25.5

←26.3

←37.9

236.5

1.028

CREWSLK
6105

237.3

1.032

1.008

→83.1

→10.9

1.000

→6045

1.023

CREWSLK
70.60

←126.3

→32.7

1.030

→6103

1.037

EATON PK
236.8

←43.2

←43.6

1.037

→9050

1.037

PEBB
238.5

1.008

→APP-CT

7961

14.09

1.021

APP-ST
7962

14.01

1.015

ARIANA
9110

236.4

1.028

→156.0

→9.5

1.021

→9102

1.021

ARIANA-N
70.48

LKAGNES
9150

236.4

1.028

←41.1

←30.5

1.033

→6101

1.033

MCINTOSH
237.5

→429.1

←12.9

1.024

→7890

1.024

OSCEOLA
235.4

GAPWAY
9160

235.9

1.026

→132.6

→21.2

1.026

→9162

1.026

→GAPWAY

70.77

2004C. sav

P mis = -0.0010 MW

Q mis = -0.0011 MVAR

General Electric Company

PSLP Program

FEAC 2004 SUMMER BASE CASE - FY1998 - REVISION 5
PROPOSED OSPREY ENERGY CENTER

HM/MVAR

Wed Feb 16 14:59:47 2000



GENERAL
ELECTRIC
COMPANY

2004C. sav
Rating * 1

RECKER
9100

1
←530.0
→12.5

←332.8
→23.4

←181.9
→21.5

→40.4
←8.3

→109.2
←15.8

←20.629
→236.4
1.028

CREWSLK
6105

←237.2
→1.031

←97.9
→9.6
1.025

6045
CREWSLK
70.69

←8.0
→14.9
1.030

6103
EATON PK
236.8

←74.4
→60.0
1.038

9050
REBB
238.7

APP-CT
7961
←14.09
→1.021

APP-ST
7962
←14.01
→1.015

ARIANA
9110
←236.3
→1.027

←181.8
→21.4
1.015

9102
ARIANA-N
70.05

LKAGNES
9150
←236.3
→1.027

←135.2
→21.6
1.033

6101
MCINTOSH
237.5

←466.6
→11.5
1.023

7890
OSCEOLA
235.2

GAPWAY
9160
←229.8
→0.955

←0.0
→0.0
1.008

9162
GAPWAY
69.55

2004d.sav
P mis = 0.0001 MW
Q mis = -0.0001 MVAR



RECKER
9100

←151.7

←21.2

←168.8

←11.0

→40.4

←8.3

→109.2

←15.8

←530.0
←13.3

←17.335

236.4
1.028

CREWSLK
6105

237.0
1.031

1.000
^^

→99.1
→9.6

6045
1.024

CREWSLK
70.65

→125.9
→3.4

6103
1.030

EATON PK
236.8

→131.4
→69.4

9050
1.038

PEBB
238.7

1.000
^^

APP-CT
7961

14.09
1.021

APP-ST
7962

14.01
1.015

ARIANA
9110

236.3
1.027

→168.8
→11.0

9102
1.021

ARIANA-N
70.43

LKABNES
9150

236.2
1.027

→398.7
→17.5

6101
1.032

MCINTOSH
237.4

→398.7
→17.5

7890
1.024

OSCEOLA
235.5

GAPWAY
9160

235.8
1.025

→151.5
→21.1

9162
1.025

GAPWAY
70.75

2004d.sav

P mis = 0.0001 MW

Q mis = -0.0001 MVAR

General Electric Company

PSLF Program



GENERAL
ELECTRIC
COMPANY

FERC 2004 SUMMER BASE CASE - FY1998 - REVISION 5
PROPOSED OSPREY ENERGY CENTER

RM/PMR

Wed Feb 16 14:05:33 2000

2004d.sav
Rating = 1

RECKER
9100

←173.6

←34.9

←334.6

→23.1

→40.4

←8.3

→109.2

←15.8

530.0
-1
←0.9

←20.6

←13

236.4
1.028

←171.4

→34.9

CREWSLK
6105

237.2
1.031

1.000

100.1
9.7

6045
1.024

CREWSLK
70.69

15.6
15.3

6103
1.030

EATON PK
236.8

186.2
161.1

9050
1.038

PEBB
238.7

APP-CT
7961

14.09
1.021

APP-ST
7962

14.01
1.015

ARIANA
9110

230.8
1.003

0.0
0.0

9102
1.001

ARIANA-N
69.05

LXAGNES
9150

236.3
1.027

136.9
21.7

6101
1.033

MCINTOSH
237.5

470.1
11.3

7890
1.023

OSCEOLA
235.2

GAPWAY
9160

235.6
1.024

173.3
34.3

9162
1.019

GAPWAY
70.31

2004d.sav

P mis = 0.0001 MW

Q mis = -0.0001 MVAR

General Electric Company PSL SYSTEM



FERC 2004 SUMMER BASE CASE - FY1998 - REVISION 5
PROPOSED OSPREY ENERGY CENTER

MM/MAR

Wed Feb 16 14:55:50 2000

2004d.sav
Rating = 1

RECKER
9100

←128.2

←21.1

←398.0

→25.4

←153.3

←9.9

→40.4

←8.3

→109.2

←15.8

530.0

←29.7

←19.663

236.4
1.028

CREWSLK
6105

237.6
1.033

1.000

→83.1

→10.5

1.000

6045

CREWSLK
70.70

←91.6

→33.4

1.030

6103
EATON PK
236.9

←18.5

→43.8

1.038

9050
PEBB
238.8

APP-CT
7961

14.09
1.021

APP-ST
7962

14.01
1.015

ARIANA
9110

236.3
1.028

→153.8

→10.0

1.021

9102
ARIANA-N
70.43

LXABNES
9150

236.2
1.027

←83.8

←30.0

6101
MEINTOSH
237.5

→479.8

←10.8

7890
OSCEOLA
235.2

GAPWAY
9160

235.9
1.025

←128.0

←21.5

1.025

9162
GAPWAY
70.73

2004d.sav
P mis = 0.0001 MW
Q mis = -0.0001 MVAR

General Electric Company

PSLF Program



GENERAL
ELECTRIC
COMPANY

FERC 2004 SUMMER BASE CASE - FY1998 - REVISION 5
PROPOSED OSPREY ENERGY CENTER

MM/MVAR

Wed Feb 16 14:56:04 2000

2004d.sav
Rating *

RECKER
9100

←332.5
→23.6

←181.8
→21.5

→40.4
←8.3

→109.2
←15.8

1

←530.0
→12.9

236.4
1.028

CREWSLK
6105

237.2
1.031

→97.9
→9.6

6045
1.025

CREWSLK
70.69

→16.6
→14.7

6103
1.030

EATON PK
236.8

→73.5
→59.9

9050
1.038

PEBB
238.7

1.008
APP-CT
7961

14.09
1.021

APP-ST
7962

14.01
1.015

ARIANA
9110

236.3
1.027

→181.8
→21.3

9102
1.015

ARIANA-N
70.05

LKAGNES
9150

236.3
1.027

→132.8
→21.7

6101
1.033

MCINTOSH
237.5

→463.9
→11.6

7890
1.023

OSCEOLA
235.3

GAPWAY
9160

229.8
0.999

←0.0
←0.0

9162
1.008

GAPWAY
69.55

2004c.sav

P mis = 0.0013 MW

Q mis = 0.0018 MVAR

General Electric Company

PLP Program



GENERAL
ELECTRIC
COMPANY

FERC 2004 SUMMER BASE CASE - FY1998 - REVISION 5
PROPOSED OSPREY ENERGY CENTER

PLP/MVAR

Wed Feb 16 17:56:23 2000

2004c.sav
Rating = 1

RECKER
9100

←151.7
←21.1

←168.7
←10.9

→40.4
←8.3

→109.2
←15.8

1
←530.0
←13.2

←18.8
←301

236.4
1.028

←359.2
→42.9

CREWSLK
6105

237.0
1.031

1.08

→99.1
→9.6

1.00
1.1.024

6045 CREWSLK
70.65

→127.0

1.030

6103 EATON PK
236.8

→130.3
→69.2

1.038

9050 PEBB
238.7

1.00
APP-ET 7961

14.09
1.021

APP-ST 7962

14.01
1.015

ARIANA 9110

235.3
1.027

→168.7
→10.9

1.021

9102 ARIANA-N
70.43

LKAGNES 9150

235.2
1.027

←396.3
→17.5

6101
1.032

MCINTOSH
237.4

→396.3
←17.5

7890
1.024

OSCEOLA
235.5

GAPWAY 9160

235.8
1.025

→151.5
→21.1

1.025

9162 GAPWAY
70.76

2004c.sav

P mis = 0.0013 MW

Q mis = 0.0018 MVAR

General Electric Company

PSLT Program

FERC 2004 SUMMER BASE CASE - FY1998 - REVISION 5
PROPOSED OSPREY ENERGY CENTER

PM/PMAR

Wed Feb 18 14:56:40 2000



GENERAL
ELECTRIC
COMPANY

2004c.sav
Rating = 1

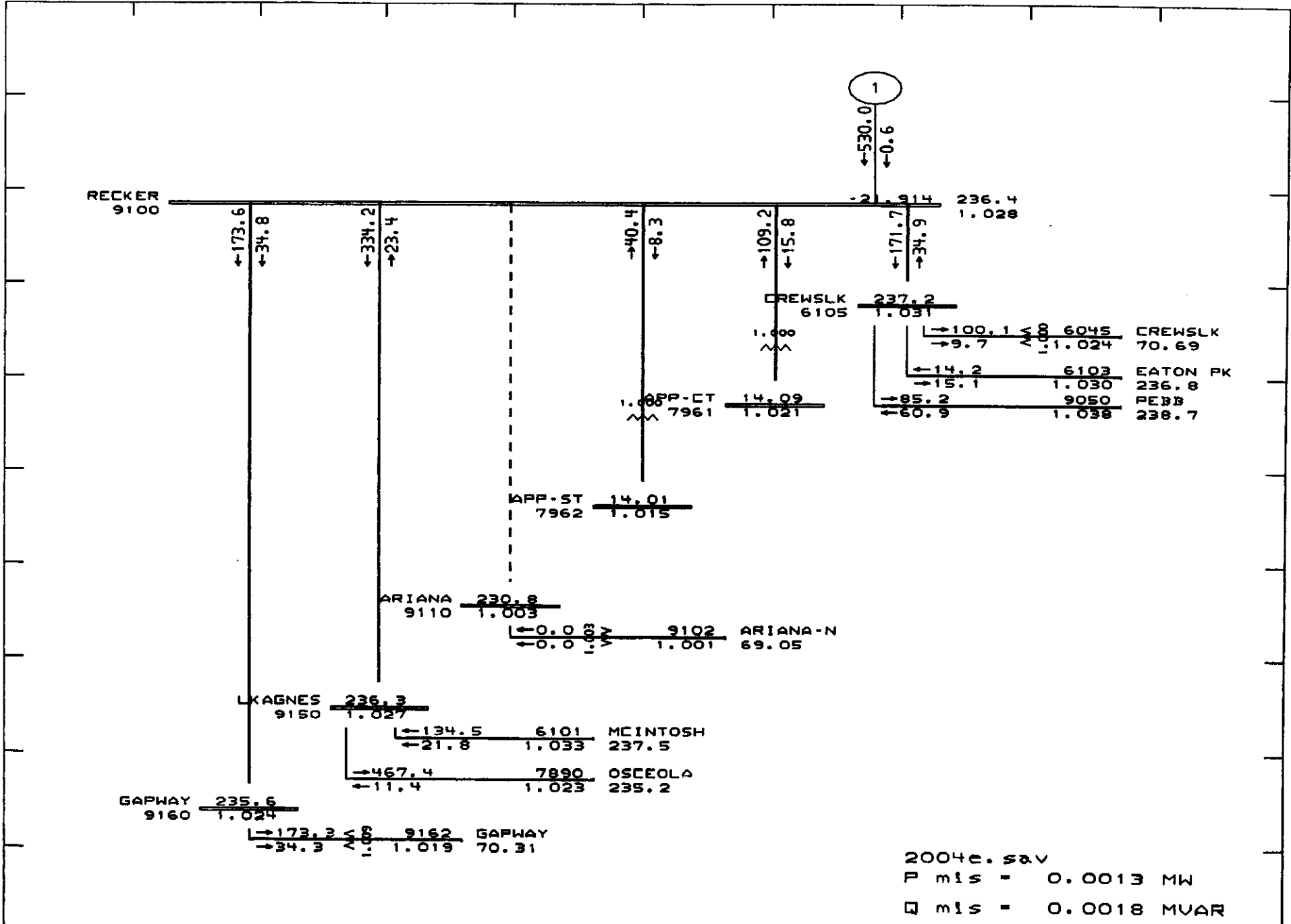

2004c.sav
 P mis = 0.0013 MW
 Q mis = 0.0018 MVAR

RECKER
9100

←128.3

←21.1

←398.0

→25.7

←153.3

←9.9

→40.4

←8.3

→109.2

←15.8

←530.0

←29.3

→20.961

236.4
1.028

CREWSLK
6105

237.6
1.033

→83.1
→10.5

6045
1.025

CREWSLK
70.70

→90.5
→33.2

6103
1.030

EATON PK
236.9

→7.4
→43.6

9050
1.038

PEBB
238.8

APP-CT
7961

14.09
1.021

APP-ST
7962

14.01
1.015

ARIANA
9110

236.3
1.028

→153.3
→9.9

9102
1.021

ARIANA-N
70.44

LXAGNES
9150

236.2
1.027

→81.1
→30.2

6101
1.033

MCINTOSH
237.5

→477.1
→10.9

7890
1.023

OSCEOLA
235.2

GAPWAY
9160

235.9
1.025

→128.2
→21.4

9162
1.025

GAPWAY
70.74

2004e. sav

P mis = 0.0013 MW

Q mis = 0.0018 MVAR

General Electric Company

PSLF Program



GENERAL
ELECTRIC
COMPANY

FERC 2004 SUMMER BASE CASE - FT1998 - REVISION 5
PROPOSED OSPREY ENERGY CENTER

04/11/00

Mod Feb 16 14:57:10 2000

2004e. sav
Rating = 1

APPENDIX III

Table III
Comparison of Line & Transformer Flows
Following N-1 Disturbances
for Various OEC 500 MW Generation Alternatives

60% Load Base Case

All Flows above 100% of Emergency rating are Shown

Monitored Branches							Case 2004-60	Case 2004-60A	Case 2004-60B	Case 2004-60C	Case 2004-60D	Case 2004-60E
Case	Bus 1	kV 1	Bus 2	kV 2	ckt	Area	Base No OEC Gen Percent	Sell to FPL Percent	Sell to FPC Percent	Sell to TEC Percent	Sell to JEA Percent	Sell to SEM Percent
2004-60-1	SN PLANT	230	SYLVAN	230	1	1						
2004-60-1	SYLVAN	230	N LONGWD	230	1	1						
2004-60-1	IND RIV	230	STANTON	230	1	11						
2004-60-1	SN PLANT	115	TURNER	115	1	1						
2004-60-1	BUCKEYE	230	RUSKMTR8	230	1	1						
2004-60-1	SILVR SP	230	SILV SPN	230	1	2						
2004-60-1	SILVR SP	230	OCALA 1	230	1	2						
2004-60-1	RIO PINR	230	CURRY FD	230	1	2						
2004-60-1	STANTON	230	CURRY FD	230	1	2						
2004-60-1	OSCEOLA	230	LKAGNES	230	1	16						
2004-60-1	SHELD	230	LK TARP	230	1	2						
2004-60-1	PEBB	230	CREWSLK	230	1	13						
2004-60-1	PEBB	230	N BARTOW	230	1	2						
2004-60-1	RECKER	230	LKAGNES	230	1	16						
2004-60-1	RECKER	230	ARIANA	230	1	16						
2004-60-1	RECKER	230	CREWSLK	230	1	13						
2004-60-1	B BEND	230	MANATEE	230	1	1						
2004-60-1	RUSKIN T	230	MANATEE	230	1	1						
2004-60-1	IND RIV	230	IND RIV	115	1	11						
2004-60-1	SHELD	230	SHELD-NW	69	1	16						
2004-60-1	LARGO	230	LARGO A	69	1	2						
2004-60-1	CLMT EST	230	CLMT EST	69	1	2						
2004-60-1	11TH AVE	230	ELEVEN-E	69	1	16						
2004-60-1	WINDERME	230	WINDERME	69	1	2						
2004-60-1	PASADENA	230	PASADENA	115	1	2						
2004-60-1	ARIANA	230	ARIANA-N	69	1	16						
2004-60-1	SELOSE	230	SELOSE-N	69	1	16						
2004-60-1	GAPWAY	230	GAPWAY	69	1	16						
2004-60-1	CREWSLK	230	CREWSLK	69	1	13						
2004-60-1	TENOROC	230	TENOROC	69	1	13						
2004-60-1	BARCOLA	230	WEST	230	1	2						
2004-60-1	EATON PK	230	CREWSLK	230	1	13						
2004-60-1	EATON PK	230	EATON PK	69	1	13						
2004-60-1	EATON PK	230	TENOROC	230	1	13						
2004-60-1	RECKER	230	GAPWAY	230	1	16						
2004-60-1	SN PLANT	115	TURNER	115	1	1						
2004-60-2	SN PLANT	230	SYLVAN	230	1	1						
2004-60-2	SYLVAN	230	N LONGWD	230	1	1						
2004-60-2	IND RIV	230	STANTON	230	1	11						
2004-60-2	SN PLANT	115	TURNER	115	1	1						
2004-60-2	BUCKEYE	230	RUSKMTR8	230	1	1						
2004-60-2	SILVR SP	230	SILV SPN	230	1	2						
2004-60-2	SILVR SP	230	OCALA 1	230	1	2						
2004-60-2	RIO PINR	230	CURRY FD	230	1	2						
2004-60-2	STANTON	230	CURRY FD	230	1	2						
2004-60-2	OSCEOLA	230	LKAGNES	230	1	16						
2004-60-2	SHELD	230	LK TARP	230	1	2						
2004-60-2	PEBB	230	CREWSLK	230	1	13						
2004-60-2	PEBB	230	N BARTOW	230	1	2						
2004-60-2	RECKER	230	LKAGNES	230	1	16						
2004-60-2	RECKER	230	ARIANA	230	1	16						
2004-60-2	RECKER	230	CREWSLK	230	1	13						
2004-60-2	B BEND	230	MANATEE	230	1	1						
2004-60-2	RUSKIN T	230	MANATEE	230	1	1						
2004-60-2	IND RIV	230	IND RIV	115	1	11						
2004-60-2	SHELD	230	SHELD-NW	69	1	16						
2004-60-2	LARGO	230	LARGO A	69	1	2						
2004-60-2	CLMT EST	230	CLMT EST	69	1	2						
2004-60-2	11TH AVE	230	ELEVEN-E	69	1	16						
2004-60-2	WINDERME	230	WINDERME	69	1	2						
2004-60-2	PASADENA	230	PASADENA	115	1	2						
2004-60-2	ARIANA	230	ARIANA-N	69	1	16						
2004-60-2	SELOSE	230	SELOSE-N	69	1	16						
2004-60-2	GAPWAY	230	GAPWAY	69	1	16						
2004-60-2	CREWSLK	230	CREWSLK	69	1	13						
2004-60-2	TENOROC	230	TENOROC	69	1	13						
2004-60-2	BARCOLA	230	WEST	230	1	2						
2004-60-2	EATON PK	230	CREWSLK	230	1	13						
2004-60-2	EATON PK	230	EATON PK	69	1	13						
2004-60-2	EATON PK	230	TENOROC	230	1	13						
2004-60-2	RECKER	230	GAPWAY	230	1	16						
2004-60-2	SN PLANT	115	TURNER	115	1	1						

Table III
Comparison of Line & Transformer Flows
Following N-1 Disturbances
for Various OEC 500 MW Generation Alternatives

60% Load Base Case

All Flows above 100% of Emergency rating are Shown

Monitored Branches							Case 2004-60	Case 2004-60A	Case 2004-60B	Case 2004-60C	Case 2004-60D	Case 2004-60E
Case	Bus 1	kV 1	Bus 2	kV 2	ckt	Area	Base No OEC Gen Percent	Sell to FPL Percent	Sell to FPC Percent	Sell to TEC Percent	Sell to JEA Percent	Sell to SEM Percent
2004-60-3	SN PLANT	230	SYLVAN	230	1	1						
2004-60-3	SYLVAN	230	N LONGWD	230	1	1						
2004-60-3	IND RIV	230	STANTON	230	1	11						
2004-60-3	SN PLANT	115	TURNER	115	1	1						
2004-60-3	BUCKEYE	230	RUSKMTR8	230	1	1						
2004-60-3	SILVR SP	230	SILV SPN	230	1	2						
2004-60-3	SILVR SP	230	OCALA 1	230	1	2						
2004-60-3	RIO PINR	230	CURRY FD	230	1	2						
2004-60-3	STANTON	230	CURRY FD	230	1	2						
2004-60-3	OSCEOLA	230	LKAGNES	230	1	16						
2004-60-3	SHELD	230	LK TARP	230	1	2						
2004-60-3	PEBB	230	CREWSLK	230	1	13						
2004-60-3	PEBB	230	N BARTOW	230	1	2						
2004-60-3	RECKER	230	LKAGNES	230	1	16						
2004-60-3	RECKER	230	ARIANA	230	1	16						
2004-60-3	RECKER	230	CREWSLK	230	1	13						
2004-60-3	B BEND	230	MANATEE	230	1	1						
2004-60-3	RUSKIN T	230	MANATEE	230	1	1						
2004-60-3	IND RIV	230	IND RIV	115	1	11						
2004-60-3	SHELD	230	SHELD-NW	69	1	16						
2004-60-3	LARGO	230	LARGO A	69	1	2						
2004-60-3	CLMT EST	230	CLMT EST	69	1	2						
2004-60-3	11TH AVE	230	ELEVEN-E	69	1	16						
2004-60-3	WINDERME	230	WINDERME	69	1	2						
2004-60-3	PASADENA	230	PASADENA	115	1	2						
2004-60-3	ARIANA	230	ARIANA-N	69	1	16						
2004-60-3	SELOSE	230	SELOSE-N	69	1	16						
2004-60-3	GAPWAY	230	GAPWAY	69	1	16						
2004-60-3	CREWSLK	230	CREWSLK	69	1	13						
2004-60-3	TENOROC	230	TENOROC	69	1	13						
2004-60-3	BARCOLA	230	WEST	230	1	2						
2004-60-3	EATON PK	230	CREWSLK	230	1	13						
2004-60-3	EATON PK	230	EATON PK	69	1	13						
2004-60-3	EATON PK	230	TENOROC	230	1	13						
2004-60-3	RECKER	230	GAPWAY	230	1	16						
2004-60-3	SN PLANT	115	TURNER	115	1	1						
2004-60-4	SN PLANT	230	SYLVAN	230	1	1						
2004-60-4	SYLVAN	230	N LONGWD	230	1	1						
2004-60-4	IND RIV	230	STANTON	230	1	11						
2004-60-4	SN PLANT	115	TURNER	115	1	1						
2004-60-4	BUCKEYE	230	RUSKMTR8	230	1	1						
2004-60-4	SILVR SP	230	SILV SPN	230	1	2						
2004-60-4	SILVR SP	230	OCALA 1	230	1	2						
2004-60-4	RIO PINR	230	CURRY FD	230	1	2						
2004-60-4	STANTON	230	CURRY FD	230	1	2						
2004-60-4	OSCEOLA	230	LKAGNES	230	1	16						
2004-60-4	SHELD	230	LK TARP	230	1	2						
2004-60-4	PEBB	230	CREWSLK	230	1	13						
2004-60-4	PEBB	230	N BARTOW	230	1	2						
2004-60-4	RECKER	230	LKAGNES	230	1	16						
2004-60-4	RECKER	230	ARIANA	230	1	16						
2004-60-4	RECKER	230	CREWSLK	230	1	13						
2004-60-4	B BEND	230	MANATEE	230	1	1						
2004-60-4	RUSKIN T	230	MANATEE	230	1	1						
2004-60-4	IND RIV	230	IND RIV	115	1	11						
2004-60-4	SHELD	230	SHELD-NW	69	1	16						
2004-60-4	LARGO	230	LARGO A	69	1	2						
2004-60-4	CLMT EST	230	CLMT EST	69	1	2						
2004-60-4	11TH AVE	230	ELEVEN-E	69	1	16						
2004-60-4	WINDERME	230	WINDERME	69	1	2						
2004-60-4	PASADENA	230	PASADENA	115	1	2						
2004-60-4	ARIANA	230	ARIANA-N	69	1	16						
2004-60-4	SELOSE	230	SELOSE-N	69	1	16						
2004-60-4	GAPWAY	230	GAPWAY	69	1	16						
2004-60-4	CREWSLK	230	CREWSLK	69	1	13						
2004-60-4	TENOROC	230	TENOROC	69	1	13						
2004-60-4	BARCOLA	230	WEST	230	1	2						
2004-60-4	EATON PK	230	CREWSLK	230	1	13						
2004-60-4	EATON PK	230	EATON PK	69	1	13						
2004-60-4	EATON PK	230	TENOROC	230	1	13						
2004-60-4	RECKER	230	GAPWAY	230	1	16						
2004-60-4	SN PLANT	115	TURNER	115	1	1						

Table III
Comparison of Line & Transformer Flows
Following N-1 Disturbances
for Various OEC 500 MW Generation Alternatives

80% Load Base Case

All Flows above 100% of Emergency rating are Shown

Monitored Branches							Case 2004-60 Base No OEC Gen	Case 2004-60A Sell to FPL	Case 2004-60B Sell to FPC	Case 2004-60C Sell to TEC	Case 2004-60D Sell to JEA	Case 2004-60E Sell to SEM
Case	Bus 1	kV 1	Bus 2	kV 2	ckt	Area	Percent	Percent	Percent	Percent	Percent	Percent
2004-60-5	SN PLANT	230	SYLVAN	230	1	1						
2004-60-5	SYLVAN	230	N LONGWD	230	1	1						
2004-60-5	IND RIV	230	STANTON	230	1	11						
2004-60-5	SN PLANT	115	TURNER	115	1	1						
2004-60-5	BUCKEYE	230	RUSKMTR8	230	1	1						
2004-60-5	SILVR SP	230	SILV SPN	230	1	2						
2004-60-5	SILVR SP	230	OCALA 1	230	1	2						
2004-60-5	RIO PINR	230	CURRY FD	230	1	2						
2004-60-5	STANTON	230	CURRY FD	230	1	2						
2004-60-5	OSCEOLA	230	LKAGNES	230	1	18						
2004-60-5	SHELD	230	LK TARPEN	230	1	2						
2004-60-5	PEBB	230	CREWSLK	230	1	13						
2004-60-5	PEBB	230	N BARTOW	230	1	2						
2004-60-5	RECKER	230	LKAGNES	230	1	16						
2004-60-5	RECKER	230	ARIANA	230	1	16						
2004-60-5	RECKER	230	CREWSLK	230	1	13						
2004-60-5	B BEND	230	MANATEE	230	1	1						
2004-60-5	RUSKIN T	230	MANATEE	230	1	1						
2004-60-5	IND RIV	230	IND RIV	115	1	11						
2004-60-5	SHELD	230	SHELD-NW	69	1	16						
2004-60-5	LARGO	230	LARGO A	69	1	2						
2004-60-5	CLMT EST	230	CLMT EST	69	1	2						
2004-60-5	11TH AVE	230	ELEVEN-E	69	1	16						
2004-60-5	WINDERME	230	WINDERME	69	1	2						
2004-60-5	PASADENA	230	PASADENA	115	1	2						
2004-60-5	ARIANA	230	ARIANA-N	69	1	16						
2004-60-5	SELOSE	230	SELOSE-N	69	1	16						
2004-60-5	GAPWAY	230	GAPWAY	69	1	16						
2004-60-5	CREWSLK	230	CREWSLK	69	1	13						
2004-60-5	TENOROC	230	TENOROC	69	1	13						
2004-60-5	BARCOLA	230	WEST	230	1	2						
2004-60-5	EATON PK	230	CREWSLK	230	1	13						
2004-60-5	EATON PK	230	EATON PK	69	1	13						
2004-60-5	EATON PK	230	TENOROC	230	1	13						
2004-60-5	RECKER	230	GAPWAY	230	1	16						
2004-60-5	SN PLANT	115	TURNER	115	1	1						
2004-60-6	SN PLANT	230	SYLVAN	230	1	1						
2004-60-6	SYLVAN	230	N LONGWD	230	1	1						
2004-60-6	IND RIV	230	STANTON	230	1	11						
2004-60-6	SN PLANT	115	TURNER	115	1	1						
2004-60-6	BUCKEYE	230	RUSKMTR8	230	1	1						
2004-60-6	SILVR SP	230	SILV SPN	230	1	2						
2004-60-6	SILVR SP	230	OCALA 1	230	1	2						
2004-60-6	RIO PINR	230	CURRY FD	230	1	2						
2004-60-6	STANTON	230	CURRY FD	230	1	2						
2004-60-6	OSCEOLA	230	LKAGNES	230	1	18						
2004-60-6	SHELD	230	LK TARPEN	230	1	2						
2004-60-6	PEBB	230	CREWSLK	230	1	13						
2004-60-6	PEBB	230	N BARTOW	230	1	2						
2004-60-6	RECKER	230	LKAGNES	230	1	16						
2004-60-6	RECKER	230	ARIANA	230	1	16						
2004-60-6	RECKER	230	CREWSLK	230	1	13						
2004-60-6	B BEND	230	MANATEE	230	1	1						
2004-60-6	RUSKIN T	230	MANATEE	230	1	1						
2004-60-6	IND RIV	230	IND RIV	115	1	11						
2004-60-6	SHELD	230	SHELD-NW	69	1	16						
2004-60-6	LARGO	230	LARGO A	69	1	2						
2004-60-6	CLMT EST	230	CLMT EST	69	1	2						
2004-60-6	11TH AVE	230	ELEVEN-E	69	1	16						
2004-60-6	WINDERME	230	WINDERME	69	1	2						
2004-60-6	PASADENA	230	PASADENA	115	1	2						
2004-60-6	ARIANA	230	ARIANA-N	69	1	16						
2004-60-6	SELOSE	230	SELOSE-N	69	1	16						
2004-60-6	GAPWAY	230	GAPWAY	69	1	16						
2004-60-6	CREWSLK	230	CREWSLK	69	1	13						
2004-60-6	TENOROC	230	TENOROC	69	1	13						
2004-60-6	BARCOLA	230	WEST	230	1	2						
2004-60-6	EATON PK	230	CREWSLK	230	1	13						
2004-60-6	EATON PK	230	EATON PK	69	1	13						
2004-60-6	EATON PK	230	TENOROC	230	1	13						
2004-60-6	RECKER	230	GAPWAY	230	1	16						
2004-60-6	SN PLANT	115	TURNER	115	1	1						

Table III
Comparison of Line & Transformer Flows
Following N-1 Disturbances
for Various OEC 500 MW Generation Alternatives

60% Load Base Case

All Flows above 100% of Emergency rating are Shown

Monitored Branches							Case 2004-60	Case 2004-60A	Case 2004-60B	Case 2004-60C	Case 2004-60D	Case 2004-60E
Case	Bus 1	kV 1	Bus 2	kV 2	ckt	Area	Base No OEC Gen Percent	Sell to FPL Percent	Sell to FPC Percent	Sell to TEC Percent	Sell to JEA Percent	Sell to SEM Percent
2004-60-7	SN PLANT	230	SYLVAN	230	1	1						
2004-60-7	SYLVAN	230	N LONGWD	230	1	1						
2004-60-7	IND RIV	230	STANTON	230	1	11						
2004-60-7	SN PLANT	115	TURNER	115	1	1						
2004-60-7	BUCKEYE	230	RUSKMT8	230	1	1						
2004-60-7	SILVR SP	230	SILV SPN	230	1	2						
2004-60-7	SILVR SP	230	OCALA 1	230	1	2						
2004-60-7	RIO PINR	230	CURRY FD	230	1	2						
2004-60-7	STANTON	230	CURRY FD	230	1	2						
2004-60-7	OSCEOLA	230	LKAGNES	230	1	16						
2004-60-7	SHELD	230	LK TARP	230	1	2						
2004-60-7	PEBB	230	CREWSLK	230	1	13						
2004-60-7	PEBB	230	N BARTOW	230	1	2						
2004-60-7	RECKER	230	LKAGNES	230	1	16						
2004-60-7	RECKER	230	ARIANA	230	1	16						
2004-60-7	RECKER	230	CREWSLK	230	1	13						
2004-60-7	B BEND	230	MANATEE	230	1	1						
2004-60-7	RUSKIN T	230	MANATEE	230	1	1						
2004-60-7	IND RIV	230	IND RIV	115	1	11						
2004-60-7	SHELD	230	SHELD-NW	69	1	16						
2004-60-7	LARGO	230	LARGO A	69	1	2						
2004-60-7	CLMT EST	230	CLMT EST	69	1	2						
2004-60-7	11TH AVE	230	ELEVEN-E	69	1	16						
2004-60-7	WINDERME	230	WINDERME	69	1	2						
2004-60-7	PASADENA	230	PASADENA	115	1	2						
2004-60-7	ARIANA	230	ARIANA-N	69	1	16						
2004-60-7	SELOSE	230	SELOSE-N	69	1	16						
2004-60-7	GAPWAY	230	GAPWAY	69	1	16						
2004-60-7	CREWSLK	230	CREWSLK	69	1	13						
2004-60-7	TENOROC	230	TENOROC	69	1	13						
2004-60-7	BARCOLA	230	WEST	230	1	2						
2004-60-7	EATON PK	230	CREWSLK	230	1	13						
2004-60-7	EATON PK	230	EATON PK	69	1	13						
2004-60-7	EATON PK	230	TENOROC	230	1	13						
2004-60-7	RECKER	230	GAPWAY	230	1	16						
2004-60-7	SN PLANT	115	TURNER	115	1	1						
2004-60-8	SN PLANT	230	SYLVAN	230	1	1						
2004-60-8	SYLVAN	230	N LONGWD	230	1	1						
2004-60-8	IND RIV	230	STANTON	230	1	11						
2004-60-8	SN PLANT	115	TURNER	115	1	1						
2004-60-8	BUCKEYE	230	RUSKMT8	230	1	1						
2004-60-8	SILVR SP	230	SILV SPN	230	1	2						
2004-60-8	SILVR SP	230	OCALA 1	230	1	2						
2004-60-8	RIO PINR	230	CURRY FD	230	1	2						
2004-60-8	STANTON	230	CURRY FD	230	1	2						
2004-60-8	OSCEOLA	230	LKAGNES	230	1	16						
2004-60-8	SHELD	230	LK TARP	230	1	2						
2004-60-8	PEBB	230	CREWSLK	230	1	13						
2004-60-8	PEBB	230	N BARTOW	230	1	2						
2004-60-8	RECKER	230	LKAGNES	230	1	16						
2004-60-8	RECKER	230	ARIANA	230	1	16						
2004-60-8	RECKER	230	CREWSLK	230	1	13						
2004-60-8	B BEND	230	MANATEE	230	1	1						
2004-60-8	RUSKIN T	230	MANATEE	230	1	1						
2004-60-8	IND RIV	230	IND RIV	115	1	11						
2004-60-8	SHELD	230	SHELD-NW	69	1	16						
2004-60-8	LARGO	230	LARGO A	69	1	2						
2004-60-8	CLMT EST	230	CLMT EST	69	1	2						
2004-60-8	11TH AVE	230	ELEVEN-E	69	1	16						
2004-60-8	WINDERME	230	WINDERME	69	1	2						
2004-60-8	PASADENA	230	PASADENA	115	1	2						
2004-60-8	ARIANA	230	ARIANA-N	69	1	16						
2004-60-8	SELOSE	230	SELOSE-N	69	1	16						
2004-60-8	GAPWAY	230	GAPWAY	69	1	16						
2004-60-8	CREWSLK	230	CREWSLK	69	1	13						
2004-60-8	TENOROC	230	TENOROC	69	1	13						
2004-60-8	BARCOLA	230	WEST	230	1	2						
2004-60-8	EATON PK	230	CREWSLK	230	1	13						
2004-60-8	EATON PK	230	EATON PK	69	1	13						
2004-60-8	EATON PK	230	TENOROC	230	1	13						
2004-60-8	RECKER	230	GAPWAY	230	1	16						
2004-60-8	SN PLANT	115	TURNER	115	1	1						

Table III
Comparison of Line & Transformer Flows
Following N-1 Disturbances
for Various OEC 500 MW Generation Alternatives

60% Load Base Case

All Flows above 100% of Emergency rating are Shown

Monitored Branches						Case 2004-60	Case 2004-60A	Case 2004-60B	Case 2004-60C	Case 2004-60D	Case 2004-60E	
Case	Bus 1	kV 1	Bus 2	kV 2	ckt	Area	Base No OEC Gen Percent	Sell to FPL Percent	Sell to FPC Percent	Sell to TEC Percent	Sell to JEA Percent	Sell to SEM Percent
2004-60-9	SN PLANT	230	SYLVAN	230	1	1						
2004-60-9	SYLVAN	230	N LONGWD	230	1	1						
2004-60-9	IND RIV	230	STANTON	230	1	11						
2004-60-9	SN PLANT	115	TURNER	115	1	1						
2004-60-9	BUCKEYE	230	RUSKMTR8	230	1	1						
2004-60-9	SILVR SP	230	SILV SPN	230	1	2						
2004-60-9	SILVR SP	230	OCALA 1	230	1	2						
2004-60-9	RIO PINR	230	CURRY FD	230	1	2						
2004-60-9	STANTON	230	CURRY FD	230	1	2						
2004-60-9	OSCEOLA	230	LKAGNES	230	1	16						
2004-60-9	SHELD	230	LK TARPEN	230	1	2						
2004-60-9	PEBB	230	CREWSLK	230	1	13						
2004-60-9	PEBB	230	N BARTOW	230	1	2						
2004-60-9	RECKER	230	LKAGNES	230	1	16						
2004-60-9	RECKER	230	ARIANA	230	1	16						
2004-60-9	RECKER	230	CREWSLK	230	1	13						
2004-60-9	B BEND	230	MANATEE	230	1	1						
2004-60-9	RUSKIN T	230	MANATEE	230	1	1						
2004-60-9	IND RIV	230	IND RIV	115	1	11						
2004-60-9	SHELD	230	SHELD-NW	69	1	16						
2004-60-9	LARGO	230	LARGO A	69	1	2						
2004-60-9	CLMT EST	230	CLMT EST	69	1	2						
2004-60-9	11TH AVE	230	ELEVEN-E	69	1	16						
2004-60-9	WINDERME	230	WINDERME	69	1	2						
2004-60-9	PASADENA	230	PASADENA	115	1	2						
2004-60-9	ARIANA	230	ARIANA-N	69	1	16						
2004-60-9	SELOSE	230	SELOSE-N	69	1	16						
2004-60-9	GAPWAY	230	GAPWAY	69	1	16						
2004-60-9	CREWSLK	230	CREWSLK	69	1	13						
2004-60-9	TENOROC	230	TENOROC	69	1	13						
2004-60-9	BARCOLA	230	WEST	230	1	2						
2004-60-9	EATON PK	230	CREWSLK	230	1	13						
2004-60-9	EATON PK	230	EATON PK	69	1	13						
2004-60-9	EATON PK	230	TENOROC	230	1	13						
2004-60-9	RECKER	230	GAPWAY	230	1	16						
2004-60-9	SN PLANT	115	TURNER	115	1	1						
2004-60-10	SN PLANT	230	SYLVAN	230	1	1						
2004-60-10	SYLVAN	230	N LONGWD	230	1	1						
2004-60-10	IND RIV	230	STANTON	230	1	11						
2004-60-10	SN PLANT	115	TURNER	115	1	1						
2004-60-10	BUCKEYE	230	RUSKMTR8	230	1	1						
2004-60-10	SILVR SP	230	SILV SPN	230	1	2						
2004-60-10	SILVR SP	230	OCALA 1	230	1	2						
2004-60-10	RIO PINR	230	CURRY FD	230	1	2						
2004-60-10	STANTON	230	CURRY FD	230	1	2						
2004-60-10	OSCEOLA	230	LKAGNES	230	1	16						
2004-60-10	SHELD	230	LK TARPEN	230	1	2						
2004-60-10	PEBB	230	CREWSLK	230	1	13						
2004-60-10	PEBB	230	N BARTOW	230	1	2						
2004-60-10	RECKER	230	LKAGNES	230	1	16						
2004-60-10	RECKER	230	ARIANA	230	1	16						
2004-60-10	RECKER	230	CREWSLK	230	1	13						
2004-60-10	B BEND	230	MANATEE	230	1	1						
2004-60-10	RUSKIN T	230	MANATEE	230	1	1						
2004-60-10	IND RIV	230	IND RIV	115	1	11						
2004-60-10	SHELD	230	SHELD-NW	69	1	16						
2004-60-10	LARGO	230	LARGO A	69	1	2						
2004-60-10	CLMT EST	230	CLMT EST	69	1	2						
2004-60-10	11TH AVE	230	ELEVEN-E	69	1	16						
2004-60-10	WINDERME	230	WINDERME	69	1	2						
2004-60-10	PASADENA	230	PASADENA	115	1	2						
2004-60-10	ARIANA	230	ARIANA-N	69	1	16						
2004-60-10	SELOSE	230	SELOSE-N	69	1	16						
2004-60-10	GAPWAY	230	GAPWAY	69	1	16						
2004-60-10	CREWSLK	230	CREWSLK	69	1	13						
2004-60-10	TENOROC	230	TENOROC	69	1	13						
2004-60-10	BARCOLA	230	WEST	230	1	2						
2004-60-10	EATON PK	230	CREWSLK	230	1	13						
2004-60-10	EATON PK	230	EATON PK	69	1	13						
2004-60-10	EATON PK	230	TENOROC	230	1	13						
2004-60-10	RECKER	230	GAPWAY	230	1	16						
2004-60-10	SN PLANT	115	TURNER	115	1	1						

Table III
Comparison of Line & Transformer Flows
Following N-1 Disturbances
for Various OEC 500 MW Generation Alternatives

60% Load Base Case

All Flows above 100% of Emergency rating are Shown

Monitored Branches							Case 2004-60A	Case 2004-60A	Case 2004-60B	Case 2004-60C	Case 2004-60D	Case 2004-60E
Case	Bus 1	kV 1	Bus 2	kV 2	ckt	Area	Base No OEC Gen Percent	Sell to FPL Percent	Sell to FPC Percent	Sell to TEC Percent	Sell to JEA Percent	Sell to SEM Percent
2004-60-11	SN PLANT	230	SYLVAN	230	1	1						
2004-60-11	SYLVAN	230	N LONGWD	230	1	1						
2004-60-11	IND RIV	230	STANTON	230	1	11						
2004-60-11	SN PLANT	115	TURNER	115	1	1						
2004-60-11	BUCKEYE	230	RUSKMTR8	230	1	1						
2004-60-11	SILVR SP	230	SILV SPN	230	1	2						
2004-60-11	SILVR SP	230	OCALA 1	230	1	2						
2004-60-11	RIO PINR	230	CURRY FD	230	1	2						
2004-60-11	STANTON	230	CURRY FD	230	1	2						
2004-60-11	OSCEOLA	230	LKAGNES	230	1	16						
2004-60-11	SHELD	230	LK TARPEN	230	1	2						
2004-60-11	PEBB	230	CREWSLK	230	1	13						
2004-60-11	PEBB	230	N BARTOW	230	1	2						
2004-60-11	RECKER	230	LKAGNES	230	1	16						
2004-60-11	RECKER	230	ARIANA	230	1	16						
2004-60-11	RECKER	230	CREWSLK	230	1	13						
2004-60-11	B BEND	230	MANATEE	230	1	1						
2004-60-11	RUSKIN T	230	MANATEE	230	1	1						
2004-60-11	IND RIV	230	IND RIV	115	1	11						
2004-60-11	SHELD	230	SHELD-NW	69	1	16						
2004-60-11	LARGO	230	LARGO A	69	1	2						
2004-60-11	CLMT EST	230	CLMT EST	69	1	2						
2004-60-11	11TH AVE	230	ELEVEN-E	69	1	16						
2004-60-11	WINDERME	230	WINDERME	69	1	2						
2004-60-11	PASADENA	230	PASADENA	115	1	2						
2004-60-11	ARIANA	230	ARIANA-N	69	1	16						
2004-60-11	SELOSE	230	SELOSE-N	69	1	16						
2004-60-11	GAPWAY	230	GAPWAY	69	1	16						
2004-60-11	CREWSLK	230	CREWSLK	69	1	13						
2004-60-11	TENOROC	230	TENOROC	69	1	13						
2004-60-11	BARCOLA	230	WEST	230	1	2						
2004-60-11	EATON PK	230	CREWSLK	230	1	13						
2004-60-11	EATON PK	230	EATON PK	69	1	13						
2004-60-11	EATON PK	230	TENOROC	230	1	13						
2004-60-11	RECKER	230	GAPWAY	230	1	16						
2004-60-11	SN PLANT	115	TURNER	115	1	1						
2004-60-12	SN PLANT	230	SYLVAN	230	1	1						
2004-60-12	SYLVAN	230	N LONGWD	230	1	1						
2004-60-12	IND RIV	230	STANTON	230	1	11						
2004-60-12	SN PLANT	115	TURNER	115	1	1						
2004-60-12	BUCKEYE	230	RUSKMTR8	230	1	1						
2004-60-12	SILVR SP	230	SILV SPN	230	1	2						
2004-60-12	SILVR SP	230	OCALA 1	230	1	2						
2004-60-12	RIO PINR	230	CURRY FD	230	1	2						
2004-60-12	STANTON	230	CURRY FD	230	1	2						
2004-60-12	OSCEOLA	230	LKAGNES	230	1	16						
2004-60-12	SHELD	230	LK TARPEN	230	1	2						
2004-60-12	PEBB	230	CREWSLK	230	1	13						
2004-60-12	PEBB	230	N BARTOW	230	1	2						
2004-60-12	RECKER	230	LKAGNES	230	1	16						
2004-60-12	RECKER	230	ARIANA	230	1	16						
2004-60-12	RECKER	230	CREWSLK	230	1	13						
2004-60-12	B BEND	230	MANATEE	230	1	1						
2004-60-12	RUSKIN T	230	MANATEE	230	1	1						
2004-60-12	IND RIV	230	IND RIV	115	1	11						
2004-60-12	SHELD	230	SHELD-NW	69	1	16						
2004-60-12	LARGO	230	LARGO A	69	1	2						
2004-60-12	CLMT EST	230	CLMT EST	69	1	2						
2004-60-12	11TH AVE	230	ELEVEN-E	69	1	16						
2004-60-12	WINDERME	230	WINDERME	69	1	2						
2004-60-12	PASADENA	230	PASADENA	115	1	2						
2004-60-12	ARIANA	230	ARIANA-N	69	1	16						
2004-60-12	SELOSE	230	SELOSE-N	69	1	16						
2004-60-12	GAPWAY	230	GAPWAY	69	1	16						
2004-60-12	CREWSLK	230	CREWSLK	69	1	13						
2004-60-12	TENOROC	230	TENOROC	69	1	13						
2004-60-12	BARCOLA	230	WEST	230	1	2						
2004-60-12	EATON PK	230	CREWSLK	230	1	13						
2004-60-12	EATON PK	230	EATON PK	69	1	13						
2004-60-12	EATON PK	230	TENOROC	230	1	13						
2004-60-12	RECKER	230	GAPWAY	230	1	16						
2004-60-12	SN PLANT	115	TURNER	115	1	1						

Table III
Comparison of Line & Transformer Flows
Following N-1 Disturbances
for Various OEC 500 MW Generation Alternatives

60% Load Base Case

All Flows above 100% of Emergency rating are Shown

Monitored Branches							Case 2004-60	Case 2004-60A	Case 2004-60B	Case 2004-60C	Case 2004-60D	Case 2004-60E
Case	Bus 1	kV 1	Bus 2	kV 2	ckt	Area	Base No OEC Gen Percent	Sell to FPL Percent	Sell to FPC Percent	Sell to TEC Percent	Sell to JEA Percent	Sell to SEM Percent
2004-60-13	SN PLANT	230	SYLVAN	230	1	1						
2004-60-13	SYLVAN	230	N LONGWD	230	1	1						
2004-60-13	IND RIV	230	STANTON	230	1	11						
2004-60-13	SN PLANT	115	TURNER	115	1	1						
2004-60-13	BUCKEYE	230	RUSKMTR8	230	1	1						
2004-60-13	SILVR SP	230	SILV SPN	230	1	2						
2004-60-13	SILVR SP	230	OCALA 1	230	1	2						
2004-60-13	RIO PINR	230	CURRY FD	230	1	2						
2004-60-13	STANTON	230	CURRY FD	230	1	2						
2004-60-13	OSCEOLA	230	LKAGNES	230	1	16						
2004-60-13	SHELD	230	LK TARPEN	230	1	2						
2004-60-13	PEBB	230	CREWSLK	230	1	13						
2004-60-13	PEBB	230	N BARTOW	230	1	2						
2004-60-13	RECKER	230	LKAGNES	230	1	16						
2004-60-13	RECKER	230	ARIANA	230	1	16						
2004-60-13	RECKER	230	CREWSLK	230	1	13						
2004-60-13	B BEND	230	MANATEE	230	1	1						
2004-60-13	RUSKIN T	230	MANATEE	230	1	1						
2004-60-13	IND RIV	230	IND RIV	115	1	11						
2004-60-13	SHELD	230	SHELD-NW	69	1	16						
2004-60-13	LARGO	230	LARGO A	69	1	2						
2004-60-13	CLMT EST	230	CLMT EST	69	1	2						
2004-60-13	11TH AVE	230	ELEVEN-E	69	1	16						
2004-60-13	WINDERME	230	WINDERME	69	1	2						
2004-60-13	PASADENA	230	PASADENA	115	1	2						
2004-60-13	ARIANA	230	ARIANA-N	69	1	16						
2004-60-13	SELOSE	230	SELOSE-N	69	1	16						
2004-60-13	GAPWAY	230	GAPWAY	69	1	16						
2004-60-13	CREWSLK	230	CREWSLK	69	1	13						
2004-60-13	TENOROC	230	TENOROC	69	1	13						
2004-60-13	BARCOLA	230	WEST	230	1	2						
2004-60-13	EATON PK	230	CREWSLK	230	1	13						
2004-60-13	EATON PK	230	EATON PK	69	1	13						
2004-60-13	EATON PK	230	TENOROC	230	1	13						
2004-60-13	RECKER	230	GAPWAY	230	1	16						
2004-60-13	SN PLANT	115	TURNER	115	1	1						
2004-60-15	SN PLANT	230	SYLVAN	230	1	1						
2004-60-15	SYLVAN	230	N LONGWD	230	1	1						
2004-60-15	IND RIV	230	STANTON	230	1	11						
2004-60-15	SN PLANT	115	TURNER	115	1	1						
2004-60-15	BUCKEYE	230	RUSKMTR8	230	1	1						
2004-60-15	SILVR SP	230	SILV SPN	230	1	2						
2004-60-15	SILVR SP	230	OCALA 1	230	1	2						
2004-60-15	RIO PINR	230	CURRY FD	230	1	2						
2004-60-15	STANTON	230	CURRY FD	230	1	2						
2004-60-15	OSCEOLA	230	LKAGNES	230	1	16						
2004-60-15	SHELD	230	LK TARPEN	230	1	2						
2004-60-15	PEBB	230	CREWSLK	230	1	13						
2004-60-15	PEBB	230	N BARTOW	230	1	2						
2004-60-15	RECKER	230	LKAGNES	230	1	16						
2004-60-15	RECKER	230	ARIANA	230	1	16						
2004-60-15	RECKER	230	CREWSLK	230	1	13						
2004-60-15	B BEND	230	MANATEE	230	1	1						
2004-60-15	RUSKIN T	230	MANATEE	230	1	1						
2004-60-15	IND RIV	230	IND RIV	115	1	11						
2004-60-15	SHELD	230	SHELD-NW	69	1	16						
2004-60-15	LARGO	230	LARGO A	69	1	2						
2004-60-15	CLMT EST	230	CLMT EST	69	1	2						
2004-60-15	11TH AVE	230	ELEVEN-E	69	1	16						
2004-60-15	WINDERME	230	WINDERME	69	1	2						
2004-60-15	PASADENA	230	PASADENA	115	1	2						
2004-60-15	ARIANA	230	ARIANA-N	69	1	16						
2004-60-15	SELOSE	230	SELOSE-N	69	1	16						
2004-60-15	GAPWAY	230	GAPWAY	69	1	16						
2004-60-15	CREWSLK	230	CREWSLK	69	1	13						
2004-60-15	TENOROC	230	TENOROC	69	1	13						
2004-60-15	BARCOLA	230	WEST	230	1	2						
2004-60-15	EATON PK	230	CREWSLK	230	1	13						
2004-60-15	EATON PK	230	EATON PK	69	1	13						
2004-60-15	EATON PK	230	TENOROC	230	1	13						
2004-60-15	RECKER	230	GAPWAY	230	1	16						
2004-60-15	SN PLANT	115	TURNER	115	1	1						

Table III
Comparison of Line & Transformer Flows
Following N-1 Disturbances
for Various OEC 500 MW Generation Alternatives

60% Load Base Case

All Flows above 100% of Emergency rating are Shown

Monitored Branches							Case 2004-60	Case 2004-60A	Case 2004-60B	Case 2004-60C	Case 2004-60D	Case 2004-60E
Case	Bus 1	kV 1	Bus 2	kV 2	ckt	Area	Base No OEC Gen Percent	Sell to FPL Percent	Sell to FPC Percent	Sell to TEC Percent	Sell to JEA Percent	Sell to SEM Percent
2004-60-16	SN PLANT	230	SYLVAN	230	1	1						
2004-60-16	SYLVAN	230	N LONGWD	230	1	1						
2004-60-16	IND RIV	230	STANTON	230	1	11						
2004-60-16	SN PLANT	115	TURNER	115	1	1						
2004-60-16	BUCKEYE	230	RUSKMTR8	230	1	1						
2004-60-16	SILVR SP	230	SILV SPN	230	1	2						
2004-60-16	SILVR SP	230	OCALA 1	230	1	2						
2004-60-16	RIO PINR	230	CURRY FD	230	1	2						
2004-60-16	STANTON	230	CURRY FD	230	1	2						
2004-60-16	OSCEOLA	230	LKAGNES	230	1	16						
2004-60-16	SHELD	230	LK TARPEN	230	1	2						
2004-60-16	PEBB	230	CREWSLK	230	1	13						
2004-60-16	PEBB	230	N BARTOW	230	1	2						
2004-60-16	RECKER	230	LKAGNES	230	1	16						
2004-60-16	RECKER	230	ARIANA	230	1	16						
2004-60-16	RECKER	230	CREWSLK	230	1	13						
2004-60-16	B BEND	230	MANATEE	230	1	1						
2004-60-16	RUSKIN T	230	MANATEE	230	1	1						
2004-60-16	IND RIV	230	IND RIV	115	1	11						
2004-60-16	SHELD	230	SHELD-NW	69	1	16						
2004-60-16	LARGO	230	LARGO A	69	1	2						
2004-60-16	CLMT EST	230	CLMT EST	69	1	2						
2004-60-16	11TH AVE	230	ELEVEN-E	69	1	16						
2004-60-16	WINDERME	230	WINDERME	69	1	2						
2004-60-16	PASADENA	230	PASADENA	115	1	2						
2004-60-16	ARIANA	230	ARIANA-N	69	1	16						
2004-60-16	SELOSE	230	SELOSE-N	69	1	16						
2004-60-16	GAPWAY	230	GAPWAY	69	1	16						
2004-60-16	CREWSLK	230	CREWSLK	69	1	13						
2004-60-16	TENOROC	230	TENOROC	69	1	13						
2004-60-16	BARCOLA	230	WEST	230	1	2						
2004-60-16	EATON PK	230	CREWSLK	230	1	13						
2004-60-16	EATON PK	230	EATON PK	69	1	13						
2004-60-16	EATON PK	230	TENOROC	230	1	13						
2004-60-16	RECKER	230	GAPWAY	230	1	16						
2004-60-16	SN PLANT	115	TURNER	115	1	1						
2004-60-17	SN PLANT	230	SYLVAN	230	1	1						
2004-60-17	SYLVAN	230	N LONGWD	230	1	1						
2004-60-17	IND RIV	230	STANTON	230	1	11						
2004-60-17	SN PLANT	115	TURNER	115	1	1						
2004-60-17	BUCKEYE	230	RUSKMTR8	230	1	1						
2004-60-17	SILVR SP	230	SILV SPN	230	1	2						
2004-60-17	SILVR SP	230	OCALA 1	230	1	2						
2004-60-17	RIO PINR	230	CURRY FD	230	1	2						
2004-60-17	STANTON	230	CURRY FD	230	1	2						
2004-60-17	OSCEOLA	230	LKAGNES	230	1	16						
2004-60-17	SHELD	230	LK TARPEN	230	1	2						
2004-60-17	PEBB	230	CREWSLK	230	1	13						
2004-60-17	PEBB	230	N BARTOW	230	1	2						
2004-60-17	RECKER	230	LKAGNES	230	1	16						
2004-60-17	RECKER	230	ARIANA	230	1	16						
2004-60-17	RECKER	230	CREWSLK	230	1	13						
2004-60-17	B BEND	230	MANATEE	230	1	1						
2004-60-17	RUSKIN T	230	MANATEE	230	1	1						
2004-60-17	IND RIV	230	IND RIV	115	1	11						
2004-60-17	SHELD	230	SHELD-NW	69	1	16						
2004-60-17	LARGO	230	LARGO A	69	1	2						
2004-60-17	CLMT EST	230	CLMT EST	69	1	2						
2004-60-17	11TH AVE	230	ELEVEN-E	69	1	16						
2004-60-17	WINDERME	230	WINDERME	69	1	2						
2004-60-17	PASADENA	230	PASADENA	115	1	2						
2004-60-17	ARIANA	230	ARIANA-N	69	1	16						
2004-60-17	SELOSE	230	SELOSE-N	69	1	16						
2004-60-17	GAPWAY	230	GAPWAY	69	1	16						
2004-60-17	CREWSLK	230	CREWSLK	69	1	13						
2004-60-17	TENOROC	230	TENOROC	69	1	13						
2004-60-17	BARCOLA	230	WEST	230	1	2						
2004-60-17	EATON PK	230	CREWSLK	230	1	13						
2004-60-17	EATON PK	230	EATON PK	69	1	13						
2004-60-17	EATON PK	230	TENOROC	230	1	13						
2004-60-17	RECKER	230	GAPWAY	230	1	16						
2004-60-17	SN PLANT	115	TURNER	115	1	1						

Table III
Comparison of Line & Transformer Flows
Following N-1 Disturbances
for Various OEC 500 MW Generation Alternatives

60% Load Base Case

All Flows above 100% of Emergency rating are Shown

Monitored Branches							Case 2004-60	Case 2004-60A	Case 2004-60B	Case 2004-60C	Case 2004-60D	Case 2004-60E
Case	Bus 1	kV 1	Bus 2	kV 2	ckt	Area	Base No OEC Gen Percent	Sell to FPL Percent	Sell to FPC Percent	Sell to TEC Percent	Sell to JEA Percent	Sell to SEM Percent
2004-60-18	SN PLANT	230	SYLVAN	230	1	1						
2004-60-18	SYLVAN	230	N LONGWD	230	1	1						
2004-60-18	IND RIV	230	STANTON	230	1	11						
2004-60-18	SN PLANT	115	TURNER	115	1	1						
2004-60-18	BUCKEYE	230	RUSKMTRB	230	1	1						
2004-60-18	SILVR SP	230	SILV SPN	230	1	2						
2004-60-18	SILVR SP	230	OCALA 1	230	1	2						
2004-60-18	RIO PINR	230	CURRY FD	230	1	2						
2004-60-18	STANTON	230	CURRY FD	230	1	2						
2004-60-18	OSCEOLA	230	LKAGNES	230	1	16						
2004-60-18	SHELD	230	LK TARP	230	1	2						
2004-60-18	PEBB	230	CREWSLK	230	1	13						
2004-60-18	PEBB	230	N BARTOW	230	1	2						
2004-60-18	RECKER	230	LKAGNES	230	1	16						
2004-60-18	RECKER	230	ARIANA	230	1	16						
2004-60-18	RECKER	230	CREWSLK	230	1	13						
2004-60-18	B BEND	230	MANATEE	230	1	1						
2004-60-18	RUSKIN T	230	MANATEE	230	1	1						
2004-60-18	IND RIV	230	IND RIV	115	1	11						
2004-60-18	SHELD	230	SHELD-NW	69	1	16						
2004-60-18	LARGO	230	LARGO A	69	1	2						
2004-60-18	CLMT EST	230	CLMT EST	69	1	2						
2004-60-18	11TH AVE	230	ELEVEN-E	69	1	16						
2004-60-18	WINDERME	230	WINDERME	69	1	2						
2004-60-18	PASADENA	230	PASADENA	115	1	2						
2004-60-18	ARIANA	230	ARIANA-N	69	1	16						
2004-60-18	SELOSE	230	SELOSE-N	69	1	16						
2004-60-18	GAPWAY	230	GAPWAY	69	1	16						
2004-60-18	CREWSLK	230	CREWSLK	69	1	13						
2004-60-18	TENOROC	230	TENOROC	69	1	13						
2004-60-18	BARCOLA	230	WEST	230	1	2						
2004-60-18	EATON PK	230	CREWSLK	230	1	13						
2004-60-18	EATON PK	230	EATON PK	69	1	13						
2004-60-18	EATON PK	230	TENOROC	230	1	13						
2004-60-18	RECKER	230	GAPWAY	230	1	16						
2004-60-18	SN PLANT	115	TURNER	115	1	1						
2004-60-19	SN PLANT	230	SYLVAN	230	1	1						
2004-60-19	SYLVAN	230	N LONGWD	230	1	1						
2004-60-19	IND RIV	230	STANTON	230	1	11						
2004-60-19	SN PLANT	115	TURNER	115	1	1						
2004-60-19	BUCKEYE	230	RUSKMTRB	230	1	1						
2004-60-19	SILVR SP	230	SILV SPN	230	1	2						
2004-60-19	SILVR SP	230	OCALA 1	230	1	2						
2004-60-19	RIO PINR	230	CURRY FD	230	1	2						
2004-60-19	STANTON	230	CURRY FD	230	1	2						
2004-60-19	OSCEOLA	230	LKAGNES	230	1	16						
2004-60-19	SHELD	230	LK TARP	230	1	2						
2004-60-19	PEBB	230	CREWSLK	230	1	13						
2004-60-19	PEBB	230	N BARTOW	230	1	2						
2004-60-19	RECKER	230	LKAGNES	230	1	16						
2004-60-19	RECKER	230	ARIANA	230	1	16						
2004-60-19	RECKER	230	CREWSLK	230	1	13						
2004-60-19	B BEND	230	MANATEE	230	1	1						
2004-60-19	RUSKIN T	230	MANATEE	230	1	1						
2004-60-19	IND RIV	230	IND RIV	115	1	11						
2004-60-19	SHELD	230	SHELD-NW	69	1	16						
2004-60-19	LARGO	230	LARGO A	69	1	2						
2004-60-19	CLMT EST	230	CLMT EST	69	1	2						
2004-60-19	11TH AVE	230	ELEVEN-E	69	1	16						
2004-60-19	WINDERME	230	WINDERME	69	1	2						
2004-60-19	PASADENA	230	PASADENA	115	1	2						
2004-60-19	ARIANA	230	ARIANA-N	69	1	16						
2004-60-19	SELOSE	230	SELOSE-N	69	1	16						
2004-60-19	GAPWAY	230	GAPWAY	69	1	16						
2004-60-19	CREWSLK	230	CREWSLK	69	1	13						
2004-60-19	TENOROC	230	TENOROC	69	1	13						
2004-60-19	BARCOLA	230	WEST	230	1	2						
2004-60-19	EATON PK	230	CREWSLK	230	1	13						
2004-60-19	EATON PK	230	EATON PK	69	1	13						
2004-60-19	EATON PK	230	TENOROC	230	1	13						
2004-60-19	RECKER	230	GAPWAY	230	1	16						
2004-60-19	SN PLANT	115	TURNER	115	1	1						

Table III
Comparison of Line & Transformer Flows
Following N-1 Disturbances
for Various OEC 500 MW Generation Alternatives

60% Load Base Case

All Flows above 100% of Emergency rating are Shown

Monitored Branches							Case 2004-60 Base No OEC Gen	Case 2004-60A Sell to FPL	Case 2004-60B Sell to FPC	Case 2004-60C Sell to TEC	Case 2004-60D Sell to JEA	Case 2004-60E Sell to SEM
Case	Bus 1	kV 1	Bus 2	kV 2	ckt	Area	Percent	Percent	Percent	Percent	Percent	Percent
2004-60-20	SN PLANT	230	SYLVAN	230	1	1						
2004-60-20	SYLVAN	230	N LONGWD	230	1	1						
2004-60-20	IND RIV	230	STANTON	230	1	11						
2004-60-20	SN PLANT	115	TURNER	115	1	1						
2004-60-20	BUCKEYE	230	RUSKMTR8	230	1	1						
2004-60-20	SILVR SP	230	SILV SPN	230	1	2						
2004-60-20	SILVR SP	230	OCALA 1	230	1	2						
2004-60-20	RIO PINR	230	CURRY FD	230	1	2						
2004-60-20	STANTON	230	CURRY FD	230	1	2						
2004-60-20	OSCEOLA	230	LKAGNES	230	1	16						
2004-60-20	SHELD	230	LK TARPEN	230	1	2						
2004-60-20	PEBB	230	CREWSLK	230	1	13						
2004-60-20	PEBB	230	N BARTOW	230	1	2						
2004-60-20	RECKER	230	LKAGNES	230	1	16						
2004-60-20	RECKER	230	ARIANA	230	1	16						
2004-60-20	RECKER	230	CREWSLK	230	1	13						
2004-60-20	B BEND	230	MANATEE	230	1	1						
2004-60-20	RUSKIN T	230	MANATEE	230	1	1						
2004-60-20	IND RIV	230	IND RIV	115	1	11						
2004-60-20	SHELD	230	SHELD-NW	69	1	16						
2004-60-20	LARGO	230	LARGO A	69	1	2						
2004-60-20	CLMT EST	230	CLMT EST	69	1	2						
2004-60-20	11TH AVE	230	ELEVEN-E	69	1	16						
2004-60-20	WINDERME	230	WINDERME	69	1	2						
2004-60-20	PASADENA	230	PASADENA	115	1	2						
2004-60-20	ARIANA	230	ARIANA-N	69	1	16						
2004-60-20	SELOSE	230	SELOSE-N	69	1	16						
2004-60-20	GAPWAY	230	GAPWAY	69	1	16						
2004-60-20	CREWSLK	230	CREWSLK	69	1	13						
2004-60-20	TENOROC	230	TENOROC	69	1	13						
2004-60-20	BARCOLA	230	WEST	230	1	2						
2004-60-20	EATON PK	230	CREWSLK	230	1	13						
2004-60-20	EATON PK	230	EATON PK	69	1	13						
2004-60-20	EATON PK	230	TENOROC	230	1	13						
2004-60-20	RECKER	230	GAPWAY	230	1	16						
2004-60-20	SN PLANT	115	TURNER	115	1	1						
2004-60-21	SN PLANT	230	SYLVAN	230	1	1						
2004-60-21	SYLVAN	230	N LONGWD	230	1	1						
2004-60-21	IND RIV	230	STANTON	230	1	11						
2004-60-21	SN PLANT	115	TURNER	115	1	1						
2004-60-21	BUCKEYE	230	RUSKMTR8	230	1	1						
2004-60-21	SILVR SP	230	SILV SPN	230	1	2						
2004-60-21	SILVR SP	230	OCALA 1	230	1	2						
2004-60-21	RIO PINR	230	CURRY FD	230	1	2						
2004-60-21	STANTON	230	CURRY FD	230	1	2						
2004-60-21	OSCEOLA	230	LKAGNES	230	1	16						
2004-60-21	SHELD	230	LK TARPEN	230	1	2						
2004-60-21	PEBB	230	CREWSLK	230	1	13						
2004-60-21	PEBB	230	N BARTOW	230	1	2						
2004-60-21	RECKER	230	LKAGNES	230	1	16						
2004-60-21	RECKER	230	ARIANA	230	1	16						
2004-60-21	RECKER	230	CREWSLK	230	1	13						
2004-60-21	B BEND	230	MANATEE	230	1	1						
2004-60-21	RUSKIN T	230	MANATEE	230	1	1						
2004-60-21	IND RIV	230	IND RIV	115	1	11						
2004-60-21	SHELD	230	SHELD-NW	69	1	16						
2004-60-21	LARGO	230	LARGO A	69	1	2						
2004-60-21	CLMT EST	230	CLMT EST	69	1	2						
2004-60-21	11TH AVE	230	ELEVEN-E	69	1	16						
2004-60-21	WINDERME	230	WINDERME	69	1	2						
2004-60-21	PASADENA	230	PASADENA	115	1	2						
2004-60-21	ARIANA	230	ARIANA-N	69	1	16						
2004-60-21	SELOSE	230	SELOSE-N	69	1	16						
2004-60-21	GAPWAY	230	GAPWAY	69	1	16						
2004-60-21	CREWSLK	230	CREWSLK	69	1	13						
2004-60-21	TENOROC	230	TENOROC	69	1	13						
2004-60-21	BARCOLA	230	WEST	230	1	2						
2004-60-21	EATON PK	230	CREWSLK	230	1	13						
2004-60-21	EATON PK	230	EATON PK	69	1	13						
2004-60-21	EATON PK	230	TENOROC	230	1	13						
2004-60-21	RECKER	230	GAPWAY	230	1	16						
2004-60-21	SN PLANT	115	TURNER	115	1	1						

Table III
Comparison of Line & Transformer Flows
Following N-1 Disturbances
for Various OEC 500 MW Generation Alternatives

60% Load Base Case

All Flows above 100% of Emergency rating are Shown

Monitored Branches							Case 2004-60	Case 2004-60A	Case 2004-60B	Case 2004-60C	Case 2004-60D	Case 2004-60E
Case	Bus 1	kV 1	Bus 2	kV 2	ckt	Area	Base No OEC Gen Percent	Sell to FPL Percent	Sell to FPC Percent	Sell to TEC Percent	Sell to JEA Percent	Sell to SEM Percent
2004-60-22	SN PLANT	230	SYLVAN	230	1	1						
2004-60-22	SYLVAN	230	N LONGWD	230	1	1						
2004-60-22	IND RIV	230	STANTON	230	1	11						
2004-60-22	SN PLANT	115	TURNER	115	1	1						
2004-60-22	BUCKEYE	230	RUSKMTR8	230	1	1						
2004-60-22	SILVR SP	230	SILV SPN	230	1	2						
2004-60-22	SILVR SP	230	OCALA 1	230	1	2						
2004-60-22	RIO PINR	230	CURRY FD	230	1	2						
2004-60-22	STANTON	230	CURRY FD	230	1	2						
2004-60-22	OSCEOLA	230	LKAGNES	230	1	16						
2004-60-22	SHELD	230	LK TARP	230	1	2						
2004-60-22	PEBB	230	CREWSLK	230	1	13						
2004-60-22	PEBB	230	N BARTOW	230	1	2						
2004-60-22	RECKER	230	LKAGNES	230	1	16						
2004-60-22	RECKER	230	ARIANA	230	1	16						
2004-60-22	RECKER	230	CREWSLK	230	1	13						
2004-60-22	B BEND	230	MANATEE	230	1	1						
2004-60-22	RUSKIN T	230	MANATEE	230	1	1						
2004-60-22	IND RIV	230	IND RIV	115	1	11						
2004-60-22	SHELD	230	SHELD-NW	69	1	16						
2004-60-22	LARGO	230	LARGO A	69	1	2						
2004-60-22	CLMT EST	230	CLMT EST	69	1	2						
2004-60-22	11TH AVE	230	ELEVEN-E	69	1	16						
2004-60-22	WINDERME	230	WINDERME	69	1	2						
2004-60-22	PASADENA	230	PASADENA	115	1	2						
2004-60-22	ARIANA	230	ARIANA-N	69	1	16						
2004-60-22	SELOSE	230	SELOSE-N	69	1	16						
2004-60-22	GAPWAY	230	GAPWAY	69	1	16						
2004-60-22	CREWSLK	230	CREWSLK	69	1	13						
2004-60-22	TENOROC	230	TENOROC	69	1	13						
2004-60-22	BARCOLA	230	WEST	230	1	2						
2004-60-22	EATON PK	230	CREWSLK	230	1	13						
2004-60-22	EATON PK	230	EATON PK	69	1	13						
2004-60-22	EATON PK	230	TENOROC	230	1	13						
2004-60-22	RECKER	230	GAPWAY	230	1	16						
2004-60-22	SN PLANT	115	TURNER	115	1	1						
2004-60-23	SN PLANT	230	SYLVAN	230	1	1						
2004-60-23	SYLVAN	230	N LONGWD	230	1	1						
2004-60-23	IND RIV	230	STANTON	230	1	11						
2004-60-23	SN PLANT	115	TURNER	115	1	1						
2004-60-23	BUCKEYE	230	RUSKMTR8	230	1	1						
2004-60-23	SILVR SP	230	SILV SPN	230	1	2						
2004-60-23	SILVR SP	230	OCALA 1	230	1	2						
2004-60-23	RIO PINR	230	CURRY FD	230	1	2						
2004-60-23	STANTON	230	CURRY FD	230	1	2						
2004-60-23	OSCEOLA	230	LKAGNES	230	1	16						
2004-60-23	SHELD	230	LK TARP	230	1	2						
2004-60-23	PEBB	230	CREWSLK	230	1	13						
2004-60-23	PEBB	230	N BARTOW	230	1	2						
2004-60-23	RECKER	230	LKAGNES	230	1	16						
2004-60-23	RECKER	230	ARIANA	230	1	16						
2004-60-23	RECKER	230	CREWSLK	230	1	13						
2004-60-23	B BEND	230	MANATEE	230	1	1						
2004-60-23	RUSKIN T	230	MANATEE	230	1	1						
2004-60-23	IND RIV	230	IND RIV	115	1	11						
2004-60-23	SHELD	230	SHELD-NW	69	1	16						
2004-60-23	LARGO	230	LARGO A	69	1	2						
2004-60-23	CLMT EST	230	CLMT EST	69	1	2						
2004-60-23	11TH AVE	230	ELEVEN-E	69	1	16						
2004-60-23	WINDERME	230	WINDERME	69	1	2						
2004-60-23	PASADENA	230	PASADENA	115	1	2						
2004-60-23	ARIANA	230	ARIANA-N	69	1	16						
2004-60-23	SELOSE	230	SELOSE-N	69	1	16						
2004-60-23	GAPWAY	230	GAPWAY	69	1	16						
2004-60-23	CREWSLK	230	CREWSLK	69	1	13						
2004-60-23	TENOROC	230	TENOROC	69	1	13						
2004-60-23	BARCOLA	230	WEST	230	1	2						
2004-60-23	EATON PK	230	CREWSLK	230	1	13						
2004-60-23	EATON PK	230	EATON PK	69	1	13						
2004-60-23	EATON PK	230	TENOROC	230	1	13						
2004-60-23	RECKER	230	GAPWAY	230	1	16						
2004-60-23	SN PLANT	115	TURNER	115	1	1						

Table III
Comparison of Line & Transformer Flows
Following N-1 Disturbances
for Various OEC 500 MW Generation Alternatives

60% Load Base Case

All Flows above 100% of Emergency rating are Shown

Monitored Branches							Case 2004-80	Case 2004-80A	Case 2004-80B	Case 2004-80C	Case 2004-80D	Case 2004-80E
Case	Bus 1	kV 1	Bus 2	kV 2	ckt	Area	Base No OEC Gen Percent	Sell to FPL Percent	Sell to FPC Percent	Sell to TEC Percent	Sell to JEA Percent	Sell to SEM Percent
2004-80-24	SN PLANT	230	SYLVAN	230	1	1						
2004-80-24	SYLVAN	230	N LONGWD	230	1	1						
2004-80-24	IND RIV	230	STANTON	230	1	11						
2004-80-24	SN PLANT	115	TURNER	115	1	1						
2004-80-24	BUCKEYE	230	RUSKMTR8	230	1	1						
2004-80-24	SILVR SP	230	SILV SPN	230	1	2						
2004-80-24	SILVR SP	230	OCALA 1	230	1	2						
2004-80-24	RIO PINR	230	CURRY FD	230	1	2						
2004-80-24	STANTON	230	CURRY FD	230	1	2						
2004-80-24	OSCEOLA	230	LKAGNES	230	1	16						
2004-80-24	SHELD	230	LK TARPEN	230	1	2						
2004-80-24	PEBB	230	CREWSLK	230	1	13						
2004-80-24	PEBB	230	N BARTOW	230	1	2						
2004-80-24	RECKER	230	LKAGNES	230	1	16						
2004-80-24	RECKER	230	ARIANA	230	1	16						
2004-80-24	RECKER	230	CREWSLK	230	1	13						
2004-80-24	B BEND	230	MANATEE	230	1	1						
2004-80-24	RUSKIN T	230	MANATEE	230	1	1						
2004-80-24	IND RIV	230	IND RIV	115	1	11						
2004-80-24	SHELD	230	SHELD-NW	69	1	16						
2004-80-24	LARGO	230	LARGO A	69	1	2						
2004-80-24	CLMT EST	230	CLMT EST	69	1	2						
2004-80-24	11TH AVE	230	ELEVEN-E	69	1	16						
2004-80-24	WINDERME	230	WINDERME	69	1	2						
2004-80-24	PASADENA	230	PASADENA	115	1	2						
2004-80-24	ARIANA	230	ARIANA-N	69	1	16						
2004-80-24	SELOSE	230	SELOSE-N	69	1	16						
2004-80-24	GAPWAY	230	GAPWAY	69	1	16						
2004-80-24	CREWSLK	230	CREWSLK	69	1	13						
2004-80-24	TENOROC	230	TENOROC	69	1	13						
2004-80-24	BARCOLA	230	WEST	230	1	2						
2004-80-24	EATON PK	230	CREWSLK	230	1	13						
2004-80-24	EATON PK	230	EATON PK	69	1	13						
2004-80-24	EATON PK	230	TENOROC	230	1	13						
2004-80-24	RECKER	230	GAPWAY	230	1	16						
2004-80-24	SN PLANT	115	TURNER	115	1	1						
2004-80-25	SN PLANT	230	SYLVAN	230	1	1						
2004-80-25	SYLVAN	230	N LONGWD	230	1	1						
2004-80-25	IND RIV	230	STANTON	230	1	11						
2004-80-25	SN PLANT	115	TURNER	115	1	1						
2004-80-25	BUCKEYE	230	RUSKMTR8	230	1	1						
2004-80-25	SILVR SP	230	SILV SPN	230	1	2						
2004-80-25	SILVR SP	230	OCALA 1	230	1	2						
2004-80-25	RIO PINR	230	CURRY FD	230	1	2						
2004-80-25	STANTON	230	CURRY FD	230	1	2						
2004-80-25	OSCEOLA	230	LKAGNES	230	1	16						
2004-80-25	SHELD	230	LK TARPEN	230	1	2						
2004-80-25	PEBB	230	CREWSLK	230	1	13						
2004-80-25	PEBB	230	N BARTOW	230	1	2						
2004-80-25	RECKER	230	LKAGNES	230	1	16						
2004-80-25	RECKER	230	ARIANA	230	1	16						
2004-80-25	RECKER	230	CREWSLK	230	1	13						
2004-80-25	B BEND	230	MANATEE	230	1	1						
2004-80-25	RUSKIN T	230	MANATEE	230	1	1						
2004-80-25	IND RIV	230	IND RIV	115	1	11						
2004-80-25	SHELD	230	SHELD-NW	69	1	16						
2004-80-25	LARGO	230	LARGO A	69	1	2						
2004-80-25	CLMT EST	230	CLMT EST	69	1	2						
2004-80-25	11TH AVE	230	ELEVEN-E	69	1	16						
2004-80-25	WINDERME	230	WINDERME	69	1	2						
2004-80-25	PASADENA	230	PASADENA	115	1	2						
2004-80-25	ARIANA	230	ARIANA-N	69	1	16						
2004-80-25	SELOSE	230	SELOSE-N	69	1	16						
2004-80-25	GAPWAY	230	GAPWAY	69	1	16						
2004-80-25	CREWSLK	230	CREWSLK	69	1	13						
2004-80-25	TENOROC	230	TENOROC	69	1	13						
2004-80-25	BARCOLA	230	WEST	230	1	2						
2004-80-25	EATON PK	230	CREWSLK	230	1	13						
2004-80-25	EATON PK	230	EATON PK	69	1	13						
2004-80-25	EATON PK	230	TENOROC	230	1	13						
2004-80-25	RECKER	230	GAPWAY	230	1	16						
2004-80-25	SN PLANT	115	TURNER	115	1	1						

Table III
Comparison of Line & Transformer Flows
Following N-1 Disturbances
for Various OEC 500 MW Generation Alternatives

60% Load Base Case

All Flows above 100% of Emergency rating are Shown

Monitored Branches							Case 2004-60	Case 2004-60A	Case 2004-60B	Case 2004-60C	Case 2004-60D	Case 2004-60E
Case	Bus 1	kV 1	Bus 2	kV 2	ckt	Area	Base No OEC Gen Percent	Sell to FPL Percent	Sell to FPC Percent	Sell to TEC Percent	Sell to JEA Percent	Sell to SEM Percent
2004-60-26	SN PLANT	230	SYLVAN	230	1	1						
2004-60-26	SYLVAN	230	N LONGWD	230	1	1						
2004-60-26	IND RIV	230	STANTON	230	1	11						
2004-60-26	SN PLANT	115	TURNER	115	1	1						
2004-60-26	BUCKEYE	230	RUSKMTR8	230	1	1						
2004-60-26	SILVR SP	230	SILV SPN	230	1	2						
2004-60-26	SILVR SP	230	OCALA 1	230	1	2						
2004-60-26	RIO PINR	230	CURRY FD	230	1	2						
2004-60-26	STANTON	230	CURRY FD	230	1	2						
2004-60-26	OSCEOLA	230	LKAGNES	230	1	16						
2004-60-26	SHELD	230	LK TARPEN	230	1	2						
2004-60-26	PEBB	230	CREWSLK	230	1	13						
2004-60-26	PEBB	230	N BARTOW	230	1	2						
2004-60-26	RECKER	230	LKAGNES	230	1	16						
2004-60-26	RECKER	230	ARIANA	230	1	16						
2004-60-26	RECKER	230	CREWSLK	230	1	13						
2004-60-26	B BEND	230	MANATEE	230	1	1						
2004-60-26	RUSKIN T	230	MANATEE	230	1	1						
2004-60-26	IND RIV	230	IND RIV	115	1	11						
2004-60-26	SHELD	230	SHELD-NW	69	1	16						
2004-60-26	LARGO	230	LARGO A	69	1	2						
2004-60-26	CLMT EST	230	CLMT EST	69	1	2						
2004-60-26	11TH AVE	230	ELEVEN-E	69	1	16						
2004-60-26	WINDERME	230	WINDERME	69	1	2						
2004-60-26	PASADENA	230	PASADENA	115	1	2						
2004-60-26	ARIANA	230	ARIANA-N	69	1	16						
2004-60-26	SELOSE	230	SELOSE-N	69	1	16						
2004-60-26	GAPWAY	230	GAPWAY	69	1	16						
2004-60-26	CREWSLK	230	CREWSLK	69	1	13						
2004-60-26	TENOROC	230	TENOROC	69	1	13						
2004-60-26	BARCOLA	230	WEST	230	1	2						
2004-60-26	EATON PK	230	CREWSLK	230	1	13						
2004-60-26	EATON PK	230	EATON PK	69	1	13						
2004-60-26	EATON PK	230	TENOROC	230	1	13						
2004-60-26	RECKER	230	GAPWAY	230	1	16						
2004-60-26	SN PLANT	115	TURNER	115	1	1						
2004-60-27	SN PLANT	230	SYLVAN	230	1	1						
2004-60-27	SYLVAN	230	N LONGWD	230	1	1						
2004-60-27	IND RIV	230	STANTON	230	1	11						
2004-60-27	SN PLANT	115	TURNER	115	1	1						
2004-60-27	BUCKEYE	230	RUSKMTR8	230	1	1						
2004-60-27	SILVR SP	230	SILV SPN	230	1	2						
2004-60-27	SILVR SP	230	OCALA 1	230	1	2						
2004-60-27	RIO PINR	230	CURRY FD	230	1	2						
2004-60-27	STANTON	230	CURRY FD	230	1	2						
2004-60-27	OSCEOLA	230	LKAGNES	230	1	16						
2004-60-27	SHELD	230	LK TARPEN	230	1	2						
2004-60-27	PEBB	230	CREWSLK	230	1	13						
2004-60-27	PEBB	230	N BARTOW	230	1	2						
2004-60-27	RECKER	230	LKAGNES	230	1	16						
2004-60-27	RECKER	230	ARIANA	230	1	16						
2004-60-27	RECKER	230	CREWSLK	230	1	13						
2004-60-27	B BEND	230	MANATEE	230	1	1						
2004-60-27	RUSKIN T	230	MANATEE	230	1	1						
2004-60-27	IND RIV	230	IND RIV	115	1	11						
2004-60-27	SHELD	230	SHELD-NW	69	1	16						
2004-60-27	LARGO	230	LARGO A	69	1	2						
2004-60-27	CLMT EST	230	CLMT EST	69	1	2						
2004-60-27	11TH AVE	230	ELEVEN-E	69	1	16						
2004-60-27	WINDERME	230	WINDERME	69	1	2						
2004-60-27	PASADENA	230	PASADENA	115	1	2						
2004-60-27	ARIANA	230	ARIANA-N	69	1	16						
2004-60-27	SELOSE	230	SELOSE-N	69	1	16						
2004-60-27	GAPWAY	230	GAPWAY	69	1	16						
2004-60-27	CREWSLK	230	CREWSLK	69	1	13						
2004-60-27	TENOROC	230	TENOROC	69	1	13						
2004-60-27	BARCOLA	230	WEST	230	1	2						
2004-60-27	EATON PK	230	CREWSLK	230	1	13						
2004-60-27	EATON PK	230	EATON PK	69	1	13						
2004-60-27	EATON PK	230	TENOROC	230	1	13						
2004-60-27	RECKER	230	GAPWAY	230	1	16						
2004-60-27	SN PLANT	115	TURNER	115	1	1						

Table III
Comparison of Line & Transformer Flows
Following N-1 Disturbances
for Various OEC 500 MW Generation Alternatives

60% Load Base Case

All Flows above 100% of Emergency rating are Shown

Monitored Branches							Case 2004-60	Case 2004-60A	Case 2004-60B	Case 2004-60C	Case 2004-60D	Case 2004-60E
Case	Bus 1	kV 1	Bus 2	kV 2	ckt	Area	Base No OEC Gen Percent	Sell to FPL Percent	Sell to FPC Percent	Sell to TEC Percent	Sell to JEA Percent	Sell to SEM Percent
2004-60-28	SN PLANT	230	SYLVAN	230	1	1						
2004-60-28	SYLVAN	230	N LONGWD	230	1	1						
2004-60-28	IND RIV	230	STANTON	230	1	11						
2004-60-28	SN PLANT	115	TURNER	115	1	1						
2004-60-28	BUCKEYE	230	RUSKMTR8	230	1	1						
2004-60-28	SILVR SP	230	SILV SPN	230	1	2						
2004-60-28	SILVR SP	230	OCALA 1	230	1	2						
2004-60-28	RIO PINR	230	CURRY FD	230	1	2						
2004-60-28	STANTON	230	CURRY FD	230	1	2						
2004-60-28	OSCEOLA	230	LKAGNES	230	1	16						
2004-60-28	SHELD	230	LK TARP	230	1	2						
2004-60-28	PEBB	230	CREWSLK	230	1	13						
2004-60-28	PEBB	230	N BARTOW	230	1	2						
2004-60-28	RECKER	230	LKAGNES	230	1	16						
2004-60-28	RECKER	230	ARIANA	230	1	16						
2004-60-28	RECKER	230	CREWSLK	230	1	13						
2004-60-28	B BEND	230	MANATEE	230	1	1						
2004-60-28	RUSKIN T	230	MANATEE	230	1	1						
2004-60-28	IND RIV	230	IND RIV	115	1	11						
2004-60-28	SHELD	230	SHELD-NW	69	1	16						
2004-60-28	LARGO	230	LARGO A	69	1	2						
2004-60-28	CLMT EST	230	CLMT EST	69	1	2						
2004-60-28	11TH AVE	230	ELEVEN-E	69	1	16						
2004-60-28	WINDERME	230	WINDERME	69	1	2						
2004-60-28	PASADENA	230	PASADENA	115	1	2						
2004-60-28	ARIANA	230	ARIANA-N	69	1	16						
2004-60-28	SELOSE	230	SELOSE-N	69	1	16						
2004-60-28	GAPWAY	230	GAPWAY	69	1	16						
2004-60-28	CREWSLK	230	CREWSLK	69	1	13						
2004-60-28	TENOROC	230	TENOROC	69	1	13						
2004-60-28	BARCOLA	230	WEST	230	1	2						
2004-60-28	EATON PK	230	CREWSLK	230	1	13						
2004-60-28	EATON PK	230	EATON PK	69	1	13						
2004-60-28	EATON PK	230	TENOROC	230	1	13						
2004-60-28	RECKER	230	GAPWAY	230	1	16						
2004-60-28	SN PLANT	115	TURNER	115	1	1						
2004-60-29	SN PLANT	230	SYLVAN	230	1	1						
2004-60-29	SYLVAN	230	N LONGWD	230	1	1						
2004-60-29	IND RIV	230	STANTON	230	1	11						
2004-60-29	SN PLANT	115	TURNER	115	1	1						
2004-60-29	BUCKEYE	230	RUSKMTR8	230	1	1						
2004-60-29	SILVR SP	230	SILV SPN	230	1	2						
2004-60-29	SILVR SP	230	OCALA 1	230	1	2						
2004-60-29	RIO PINR	230	CURRY FD	230	1	2						
2004-60-29	STANTON	230	CURRY FD	230	1	2						
2004-60-29	OSCEOLA	230	LKAGNES	230	1	16						
2004-60-29	SHELD	230	LK TARP	230	1	2						
2004-60-29	PEBB	230	CREWSLK	230	1	13						
2004-60-29	PEBB	230	N BARTOW	230	1	2						
2004-60-29	RECKER	230	LKAGNES	230	1	16						
2004-60-29	RECKER	230	ARIANA	230	1	16						
2004-60-29	RECKER	230	CREWSLK	230	1	13						
2004-60-29	B BEND	230	MANATEE	230	1	1						
2004-60-29	RUSKIN T	230	MANATEE	230	1	1						
2004-60-29	IND RIV	230	IND RIV	115	1	11						
2004-60-29	SHELD	230	SHELD-NW	69	1	16						
2004-60-29	LARGO	230	LARGO A	69	1	2						
2004-60-29	CLMT EST	230	CLMT EST	69	1	2						
2004-60-29	11TH AVE	230	ELEVEN-E	69	1	16						
2004-60-29	WINDERME	230	WINDERME	69	1	2						
2004-60-29	PASADENA	230	PASADENA	115	1	2						
2004-60-29	ARIANA	230	ARIANA-N	69	1	16						
2004-60-29	SELOSE	230	SELOSE-N	69	1	16						
2004-60-29	GAPWAY	230	GAPWAY	69	1	16						
2004-60-29	CREWSLK	230	CREWSLK	69	1	13						
2004-60-29	TENOROC	230	TENOROC	69	1	13						
2004-60-29	BARCOLA	230	WEST	230	1	2						
2004-60-29	EATON PK	230	CREWSLK	230	1	13						
2004-60-29	EATON PK	230	EATON PK	69	1	13						
2004-60-29	EATON PK	230	TENOROC	230	1	13						
2004-60-29	RECKER	230	GAPWAY	230	1	16						
2004-60-29	SN PLANT	115	TURNER	115	1	1						

Table III
Comparison of Line & Transformer Flows
Following N-1 Disturbances
for Various OEC 500 MW Generation Alternatives

60% Load Base Case

All Flows above 100% of Emergency rating are Shown

Monitored Branches							Case 2004-60	Case 2004-60A	Case 2004-60B	Case 2004-60C	Case 2004-60D	Case 2004-60E
Case	Bus 1	kV 1	Bus 2	kV 2	ckt	Area	Base No OEC Gen Percent	Sell to FPL Percent	Sell to FPC Percent	Sell to TEC Percent	Sell to JEA Percent	Sell to SEM Percent
2004-60-30	SN PLANT	230	SYLVAN	230	1	1						
2004-60-30	SYLVAN	230	N LONGWD	230	1	1						
2004-60-30	IND RIV	230	STANTON	230	1	11						
2004-60-30	SN PLANT	115	TURNER	115	1	1						
2004-60-30	BUCKEYE	230	RUSKMTR8	230	1	1						
2004-60-30	SILVR SP	230	SILV SPN	230	1	2						
2004-60-30	SILVR SP	230	OCALA 1	230	1	2						
2004-60-30	RIO PINR	230	CURRY FD	230	1	2						
2004-60-30	STANTON	230	CURRY FD	230	1	2						
2004-60-30	OSCEOLA	230	LKAGNES	230	1	16						
2004-60-30	SHELD	230	LK TARP	230	1	2						
2004-60-30	PEBB	230	CREWSLK	230	1	13						
2004-60-30	PEBB	230	N BARTOW	230	1	2						
2004-60-30	RECKER	230	LKAGNES	230	1	16						
2004-60-30	RECKER	230	ARIANA	230	1	16						
2004-60-30	RECKER	230	CREWSLK	230	1	13						
2004-60-30	B BEND	230	MANATEE	230	1	1						
2004-60-30	RUSKIN T	230	MANATEE	230	1	1						
2004-60-30	IND RIV	230	IND RIV	115	1	11						
2004-60-30	SHELD	230	SHELD-NW	69	1	16						
2004-60-30	LARGO	230	LARGO A	69	1	2						
2004-60-30	CLMT EST	230	CLMT EST	69	1	2						
2004-60-30	11TH AVE	230	ELEVEN-E	69	1	16						
2004-60-30	WINDERME	230	WINDERME	69	1	2						
2004-60-30	PASADENA	230	PASADENA	115	1	2						
2004-60-30	ARIANA	230	ARIANA-N	69	1	16						
2004-60-30	SELOSE	230	SELOSE-N	69	1	16						
2004-60-30	GAPWAY	230	GAPWAY	69	1	16						
2004-60-30	CREWSLK	230	CREWSLK	69	1	13						
2004-60-30	TENOROC	230	TENOROC	69	1	13						
2004-60-30	BARCOLA	230	WEST	230	1	2						
2004-60-30	EATON PK	230	CREWSLK	230	1	13						
2004-60-30	EATON PK	230	EATON PK	69	1	13						
2004-60-30	EATON PK	230	TENOROC	230	1	13						
2004-60-30	RECKER	230	GAPWAY	230	1	16						
2004-60-30	SN PLANT	115	TURNER	115	1	1						
2004-60-31	SN PLANT	230	SYLVAN	230	1	1						
2004-60-31	SYLVAN	230	N LONGWD	230	1	1						
2004-60-31	IND RIV	230	STANTON	230	1	11						
2004-60-31	SN PLANT	115	TURNER	115	1	1						
2004-60-31	BUCKEYE	230	RUSKMTR8	230	1	1						
2004-60-31	SILVR SP	230	SILV SPN	230	1	2						
2004-60-31	SILVR SP	230	OCALA 1	230	1	2						
2004-60-31	RIO PINR	230	CURRY FD	230	1	2						
2004-60-31	STANTON	230	CURRY FD	230	1	2						
2004-60-31	OSCEOLA	230	LKAGNES	230	1	16						
2004-60-31	SHELD	230	LK TARP	230	1	2						
2004-60-31	PEBB	230	CREWSLK	230	1	13						
2004-60-31	PEBB	230	N BARTOW	230	1	2						
2004-60-31	RECKER	230	LKAGNES	230	1	16						
2004-60-31	RECKER	230	ARIANA	230	1	16						
2004-60-31	RECKER	230	CREWSLK	230	1	13						
2004-60-31	B BEND	230	MANATEE	230	1	1						
2004-60-31	RUSKIN T	230	MANATEE	230	1	1						
2004-60-31	IND RIV	230	IND RIV	115	1	11						
2004-60-31	SHELD	230	SHELD-NW	69	1	16						
2004-60-31	LARGO	230	LARGO A	69	1	2						
2004-60-31	CLMT EST	230	CLMT EST	69	1	2						
2004-60-31	11TH AVE	230	ELEVEN-E	69	1	16						
2004-60-31	WINDERME	230	WINDERME	69	1	2						
2004-60-31	PASADENA	230	PASADENA	115	1	2						
2004-60-31	ARIANA	230	ARIANA-N	69	1	16						
2004-60-31	SELOSE	230	SELOSE-N	69	1	16						
2004-60-31	GAPWAY	230	GAPWAY	69	1	16						
2004-60-31	CREWSLK	230	CREWSLK	69	1	13						
2004-60-31	TENOROC	230	TENOROC	69	1	13						
2004-60-31	BARCOLA	230	WEST	230	1	2						
2004-60-31	EATON PK	230	CREWSLK	230	1	13						
2004-60-31	EATON PK	230	EATON PK	69	1	13						
2004-60-31	EATON PK	230	TENOROC	230	1	13						
2004-60-31	RECKER	230	GAPWAY	230	1	16						
2004-60-31	SN PLANT	115	TURNER	115	1	1						

Table III
Comparison of Line & Transformer Flows
Following N-1 Disturbances
for Various OEC 500 MW Generation Alternatives

60% Load Base Case

All Flows above 100% of Emergency rating are Shown

Monitored Branches							Case 2004-60	Case 2004-60A	Case 2004-60B	Case 2004-60C	Case 2004-60D	Case 2004-60E
Case	Bus 1	KV 1	Bus 2	KV 2	ckt	Area	Base No OEC Gen Percent	Sell to FPL Percent	Sell to FPC Percent	Sell to TEC Percent	Sell to JEA Percent	Sell to SEM Percent
2004-60-32	SN PLANT	230	SYLVAN	230	1	1						
2004-60-32	SYLVAN	230	N LONGWD	230	1	1						
2004-60-32	IND RIV	230	STANTON	230	1	11						
2004-60-32	SN PLANT	115	TURNER	115	1	1						
2004-60-32	BUCKEYE	230	RUSKMTR8	230	1	1						
2004-60-32	SILVR SP	230	SILV SPN	230	1	2						
2004-60-32	SILVR SP	230	OCALA 1	230	1	2						
2004-60-32	RIO PINR	230	CURRY FD	230	1	2						
2004-60-32	STANTON	230	CURRY FD	230	1	2						
2004-60-32	OSCEOLA	230	LKAGNES	230	1	16						
2004-60-32	SHELD	230	LK TARPEN	230	1	2						
2004-60-32	PEBB	230	CREWSLK	230	1	13						
2004-60-32	PEBB	230	N BARTOW	230	1	2						
2004-60-32	RECKER	230	LKAGNES	230	1	16						
2004-60-32	RECKER	230	ARIANA	230	1	16						
2004-60-32	RECKER	230	CREWSLK	230	1	13						
2004-60-32	B BEND	230	MANATEE	230	1	1						
2004-60-32	RUSKIN T	230	MANATEE	230	1	1						
2004-60-32	IND RIV	230	IND RIV	115	1	11						
2004-60-32	SHELD	230	SHELD-NW	69	1	16						
2004-60-32	LARGO	230	LARGO A	69	1	2						
2004-60-32	CLMT EST	230	CLMT EST	69	1	2						
2004-60-32	11TH AVE	230	ELEVEN-E	69	1	16						
2004-60-32	WINDERME	230	WINDERME	69	1	2						
2004-60-32	PASADENA	230	PASADENA	115	1	2						
2004-60-32	ARIANA	230	ARIANA-N	69	1	16						
2004-60-32	SELOSE	230	SELOSE-N	69	1	16						
2004-60-32	GAPWAY	230	GAPWAY	69	1	16						
2004-60-32	CREWSLK	230	CREWSLK	69	1	13						
2004-60-32	TENOROC	230	TENOROC	69	1	13						
2004-60-32	BARCOLA	230	WEST	230	1	2						
2004-60-32	EATON PK	230	CREWSLK	230	1	13						
2004-60-32	EATON PK	230	EATON PK	69	1	13						
2004-60-32	EATON PK	230	TENOROC	230	1	13						
2004-60-32	RECKER	230	GAPWAY	230	1	16						
2004-60-32	SN PLANT	115	TURNER	115	1	1						
2004-60-33	SN PLANT	230	SYLVAN	230	1	1						
2004-60-33	SYLVAN	230	N LONGWD	230	1	1						
2004-60-33	IND RIV	230	STANTON	230	1	11						
2004-60-33	SN PLANT	115	TURNER	115	1	1						
2004-60-33	BUCKEYE	230	RUSKMTR8	230	1	1						
2004-60-33	SILVR SP	230	SILV SPN	230	1	2						
2004-60-33	SILVR SP	230	OCALA 1	230	1	2						
2004-60-33	RIO PINR	230	CURRY FD	230	1	2						
2004-60-33	STANTON	230	CURRY FD	230	1	2						
2004-60-33	OSCEOLA	230	LKAGNES	230	1	16						
2004-60-33	SHELD	230	LK TARPEN	230	1	2						
2004-60-33	PEBB	230	CREWSLK	230	1	13						
2004-60-33	PEBB	230	N BARTOW	230	1	2						
2004-60-33	RECKER	230	LKAGNES	230	1	16						
2004-60-33	RECKER	230	ARIANA	230	1	16						
2004-60-33	RECKER	230	CREWSLK	230	1	13						
2004-60-33	B BEND	230	MANATEE	230	1	1						
2004-60-33	RUSKIN T	230	MANATEE	230	1	1						
2004-60-33	IND RIV	230	IND RIV	115	1	11						
2004-60-33	SHELD	230	SHELD-NW	69	1	16						
2004-60-33	LARGO	230	LARGO A	69	1	2						
2004-60-33	CLMT EST	230	CLMT EST	69	1	2						
2004-60-33	11TH AVE	230	ELEVEN-E	69	1	16						
2004-60-33	WINDERME	230	WINDERME	69	1	2						
2004-60-33	PASADENA	230	PASADENA	115	1	2						
2004-60-33	ARIANA	230	ARIANA-N	69	1	16						
2004-60-33	SELOSE	230	SELOSE-N	69	1	16						
2004-60-33	GAPWAY	230	GAPWAY	69	1	16						
2004-60-33	CREWSLK	230	CREWSLK	69	1	13						
2004-60-33	TENOROC	230	TENOROC	69	1	13						
2004-60-33	BARCOLA	230	WEST	230	1	2						
2004-60-33	EATON PK	230	CREWSLK	230	1	13						
2004-60-33	EATON PK	230	EATON PK	69	1	13						
2004-60-33	EATON PK	230	TENOROC	230	1	13						
2004-60-33	RECKER	230	GAPWAY	230	1	16						
2004-60-33	SN PLANT	115	TURNER	115	1	1						

Table III
Comparison of Line & Transformer Flows
Following N-1 Disturbances
for Various OEC 500 MW Generation Alternatives

60% Load Base Case

All Flows above 100% of Emergency rating are Shown

Monitored Branches							Case 2004-60	Case 2004-60A	Case 2004-60B	Case 2004-60C	Case 2004-60D	Case 2004-60E
Case	Bus 1	kV 1	Bus 2	kV 2	ckt	Area	Base No OEC Gen Percent	Sell to FPL Percent	Sell to FPC Percent	Sell to TEC Percent	Sell to JEA Percent	Sell to SEM Percent
2004-60-34	SN PLANT	230	SYLVAN	230	1	1						
2004-60-34	SYLVAN	230	N LONGWD	230	1	1						
2004-60-34	IND RIV	230	STANTON	230	1	11						
2004-60-34	SN PLANT	115	TURNER	115	1	1						
2004-60-34	BUCKEYE	230	RUSKMTR8	230	1	1						
2004-60-34	SILVR SP	230	SILV SPN	230	1	2						
2004-60-34	SILVR SP	230	OCALA 1	230	1	2						
2004-60-34	RIO PINR	230	CURRY FD	230	1	2						
2004-60-34	STANTON	230	CURRY FD	230	1	2						
2004-60-34	OSCEOLA	230	LKAGNES	230	1	16						
2004-60-34	SHELD	230	LK TARP	230	1	2						
2004-60-34	PEBB	230	CREWSLK	230	1	13						
2004-60-34	PEBB	230	N BARTOW	230	1	2						
2004-60-34	RECKER	230	LKAGNES	230	1	16						
2004-60-34	RECKER	230	ARIANA	230	1	16						
2004-60-34	RECKER	230	CREWSLK	230	1	13						
2004-60-34	B BEND	230	MANATEE	230	1	1						
2004-60-34	RUSKIN T	230	MANATEE	230	1	1						
2004-60-34	IND RIV	230	IND RIV	115	1	11						
2004-60-34	SHELD	230	SHELD-NW	69	1	16						
2004-60-34	LARGO	230	LARGO A	69	1	2						
2004-60-34	CLMT EST	230	CLMT EST	69	1	2						
2004-60-34	11TH AVE	230	ELEVEN-E	69	1	16						
2004-60-34	WINDERME	230	WINDERME	69	1	2						
2004-60-34	PASADENA	230	PASADENA	115	1	2						
2004-60-34	ARIANA	230	ARIANA-N	69	1	16						
2004-60-34	SELOSE	230	SELOSE-N	69	1	16						
2004-60-34	GAPWAY	230	GAPWAY	69	1	16						
2004-60-34	CREWSLK	230	CREWSLK	69	1	13						
2004-60-34	TENOROC	230	TENOROC	69	1	13						
2004-60-34	BARCOLA	230	WEST	230	1	2						
2004-60-34	EATON PK	230	CREWSLK	230	1	13						
2004-60-34	EATON PK	230	EATON PK	69	1	13						
2004-60-34	EATON PK	230	TENOROC	230	1	13						
2004-60-34	RECKER	230	GAPWAY	230	1	16						
2004-60-34	SN PLANT	115	TURNER	115	1	1						
2004-60-35	SN PLANT	230	SYLVAN	230	1	1						
2004-60-35	SYLVAN	230	N LONGWD	230	1	1						
2004-60-35	IND RIV	230	STANTON	230	1	11						
2004-60-35	SN PLANT	115	TURNER	115	1	1						
2004-60-35	BUCKEYE	230	RUSKMTR8	230	1	1						
2004-60-35	SILVR SP	230	SILV SPN	230	1	2						
2004-60-35	SILVR SP	230	OCALA 1	230	1	2						
2004-60-35	RIO PINR	230	CURRY FD	230	1	2						
2004-60-35	STANTON	230	CURRY FD	230	1	2						
2004-60-35	OSCEOLA	230	LKAGNES	230	1	16						
2004-60-35	SHELD	230	LK TARP	230	1	2						
2004-60-35	PEBB	230	CREWSLK	230	1	13						
2004-60-35	PEBB	230	N BARTOW	230	1	2						
2004-60-35	RECKER	230	LKAGNES	230	1	16						
2004-60-35	RECKER	230	ARIANA	230	1	16						
2004-60-35	RECKER	230	CREWSLK	230	1	13						
2004-60-35	B BEND	230	MANATEE	230	1	1						
2004-60-35	RUSKIN T	230	MANATEE	230	1	1						
2004-60-35	IND RIV	230	IND RIV	115	1	11						
2004-60-35	SHELD	230	SHELD-NW	69	1	16						
2004-60-35	LARGO	230	LARGO A	69	1	2						
2004-60-35	CLMT EST	230	CLMT EST	69	1	2						
2004-60-35	11TH AVE	230	ELEVEN-E	69	1	16						
2004-60-35	WINDERME	230	WINDERME	69	1	2						
2004-60-35	PASADENA	230	PASADENA	115	1	2						
2004-60-35	ARIANA	230	ARIANA-N	69	1	16						
2004-60-35	SELOSE	230	SELOSE-N	69	1	16						
2004-60-35	GAPWAY	230	GAPWAY	69	1	16						
2004-60-35	CREWSLK	230	CREWSLK	69	1	13						
2004-60-35	TENOROC	230	TENOROC	69	1	13						
2004-60-35	BARCOLA	230	WEST	230	1	2						
2004-60-35	EATON PK	230	CREWSLK	230	1	13						
2004-60-35	EATON PK	230	EATON PK	69	1	13						
2004-60-35	EATON PK	230	TENOROC	230	1	13						
2004-60-35	RECKER	230	GAPWAY	230	1	16						
2004-60-35	SN PLANT	115	TURNER	115	1	1						

APPENDIX III-A

RECKER
9100

←70.2

←11.8

←30.2

→5.4

←80.2

→5.2

→40.4

←8.3

→109.2

←15.7

1

-37.792

236.9
1.030

→31.1

→25.1

CREWSLK
6105

238.1
1.035

→63.4
←17.8

6045
0.1025

CREWSLK
70.74

→47.4
→32.4

6103
1.032

EATON PK
237.4

→47.1
→35.4

9050
1.040

PEBB
239.3

APP-CT
7961

14.12
1.023

APP-ST
7962

14.04
1.017

ARIANA
9110

236.9
1.030

→80.2
←4.8

9102
1.030

ARIANA-N
71.06

LXAGNES
9150

236.9
1.030

←183.0
→13.4

6101
1.031

MCINTOSH
237.2

→213.2
←15.4

7890
1.028

OSCEOLA
236.5

GAPWAY
9160

236.6
1.029

→70.2
→12.9

9162
1.032

GAPWAY
71.19

2004-60.sav

P mis = 0.0007 MW

Q mis = -0.0029 MVAR

General Electric Company

PSLF Program

FERC 2004 SUMMER BASE CASE - FY1998 - REVISION 5
PROPOSED OSPREY ENERGY CENTER

MW/MVAR

Fri Feb 25 10:08:29 2000



GENERAL
ELECTRIC
COMPANY

2004-60.sav
Rating = 1

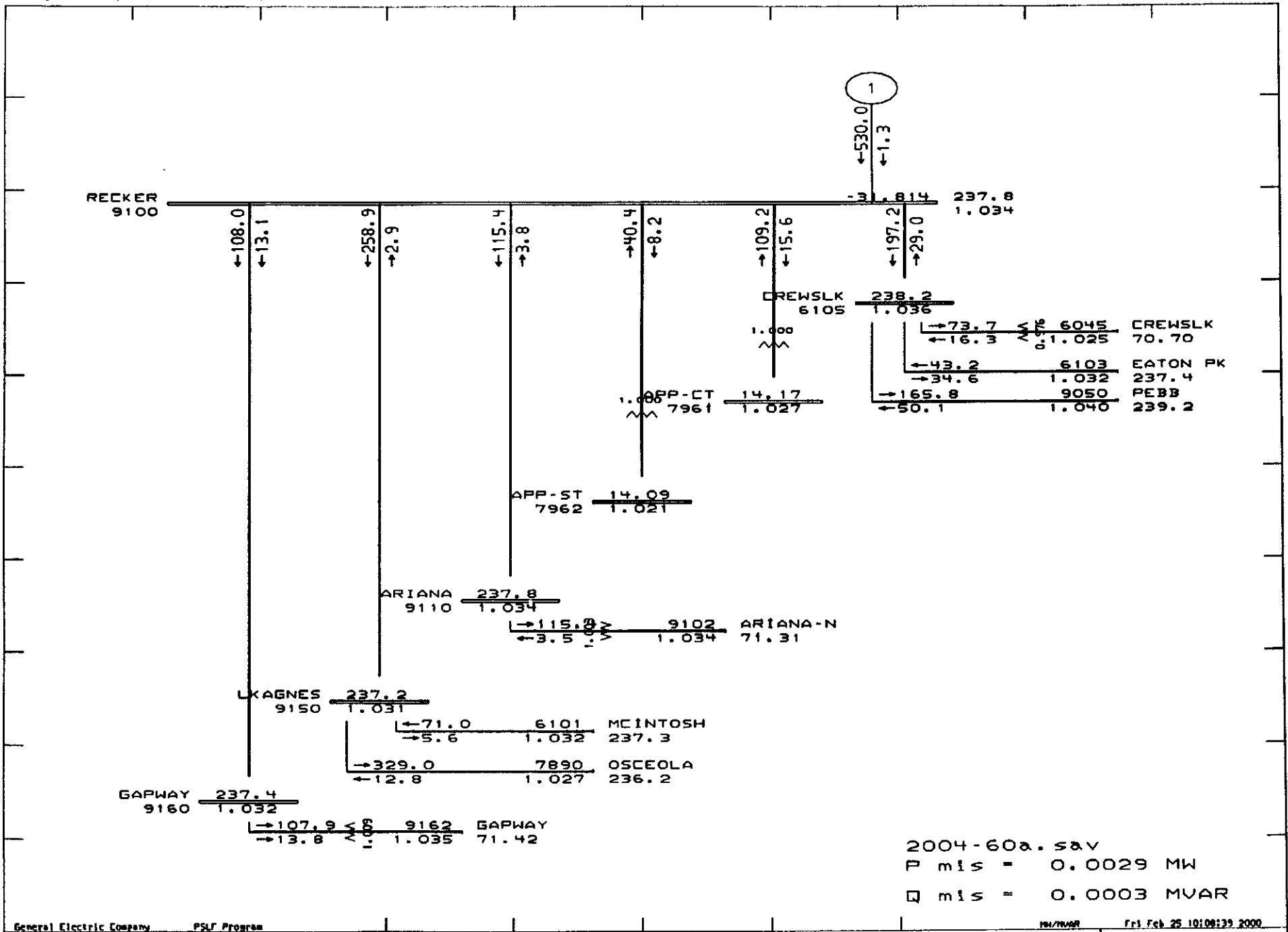

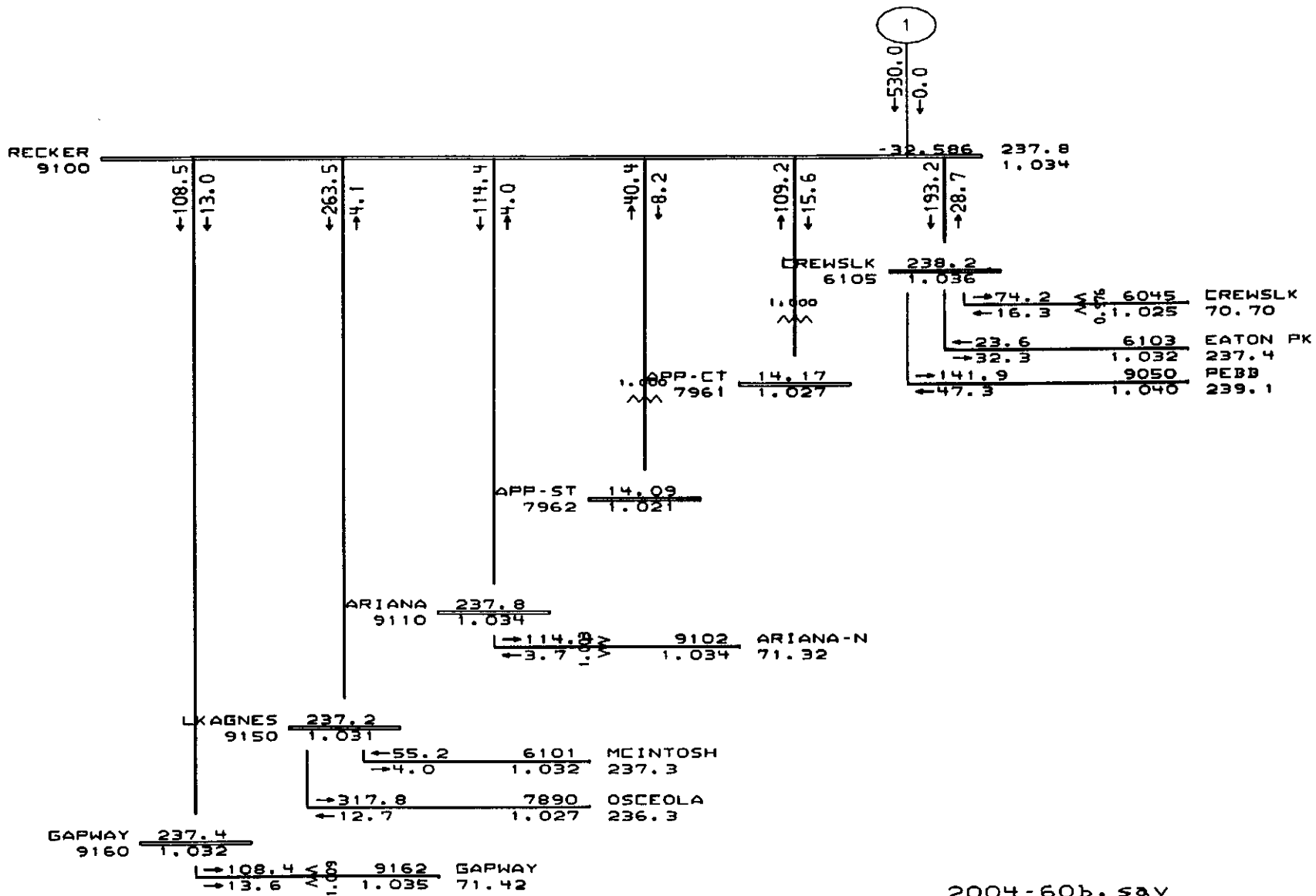

2004-60b.sav
P mis = -0.0047 MW
Q mis = -0.0007 MVAR

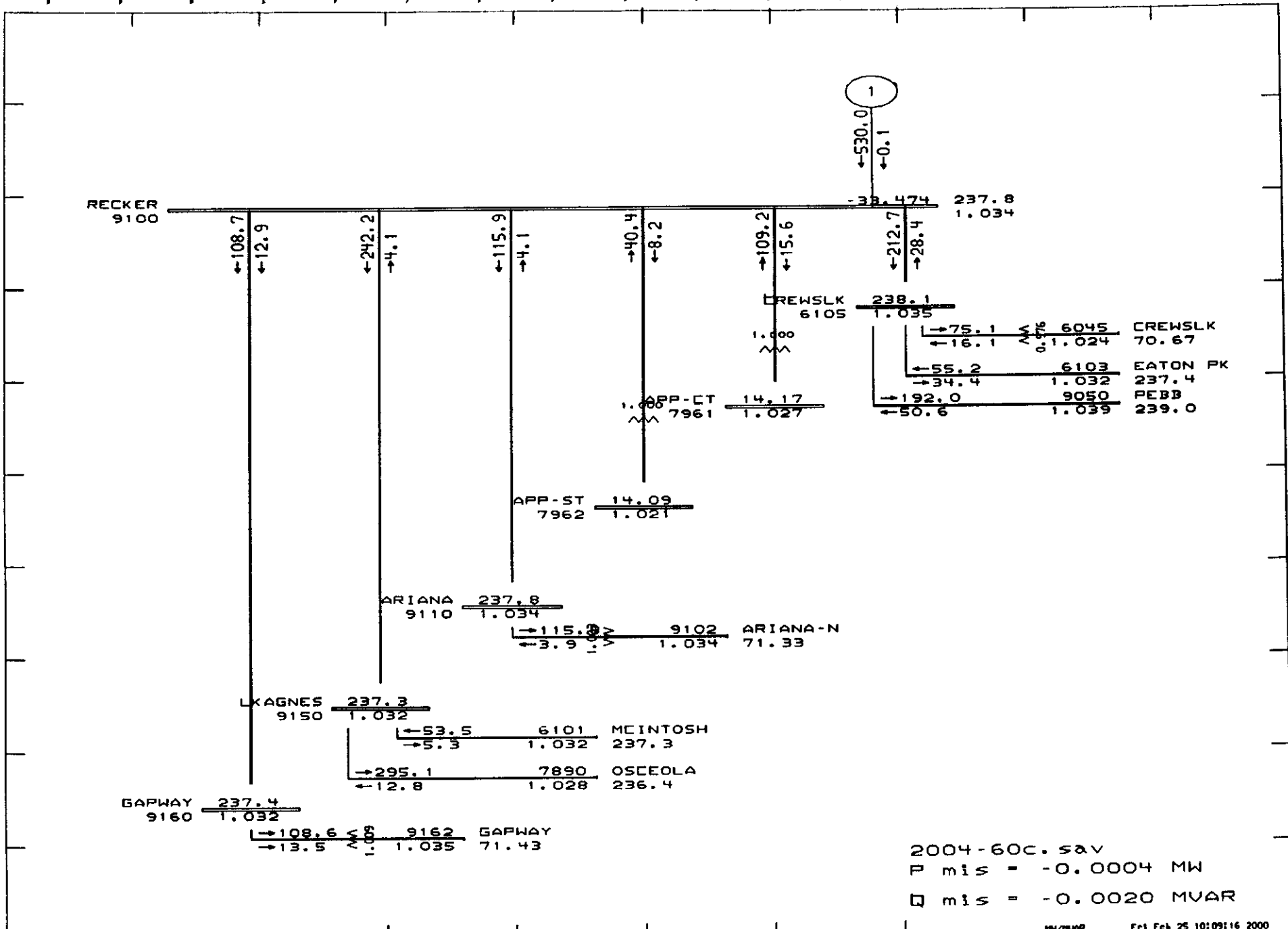

2004-60c.sav
P mis = -0.0004 MW
Q mis = -0.0020 MVAR

RECKER
9100

←107.7

←13.2

←270.8

→2.2

←115.1

→3.6

→40.4

←8.2

→109.2

←15.6

←27.601

←530.0

←2.6

237.8

1.034

CREWSLK
6105

238.2

1.036

1.000

1.000

→73.6 MW

←16.4 MW

→31.0 MW

→33.7 MW

→142.7 MW

→48.0 MW

0.976

0.1025

1.032

1.040

1.040

6045 CREWSLK
70.71

6103 EATON PK
237.4

9050 FEBB
239.2

APP-CT
7961

14.17

1.027

APP-ST
7962

14.09

1.021

ARIANA
9110

237.8

1.034

→115.0 MW

←3.3 MW

9102

1.033

ARIANA-N
71.30

LKAGNES
9150

237.2

1.031

←79.3 MW

→5.4 MW

→349.2 MW

←12.7 MW

6101 MCINTOSH
237.3

1.032

7890 OSCEOLA
236.2

1.027

GAPWAY
9160

237.4

1.032

→107.6 MW

→13.9 MW

1.008

1.035

9162 GAPWAY
71.42

1.035

2004-60d.sav

P mis = 0.0011 MW

Q mis = 0.0010 MVAR

PW/MVAR

Fri Feb 25 10:09:28 2000

General Electric Company

PSLF Program

FERC 2004 SUMMER BASE CASE - FY1998 - REVISION 5
PROPOSED OSPREY ENERGY CENTER



GENERAL
ELECTRIC
COMPANY

2004-60d.sav
Rating = 1

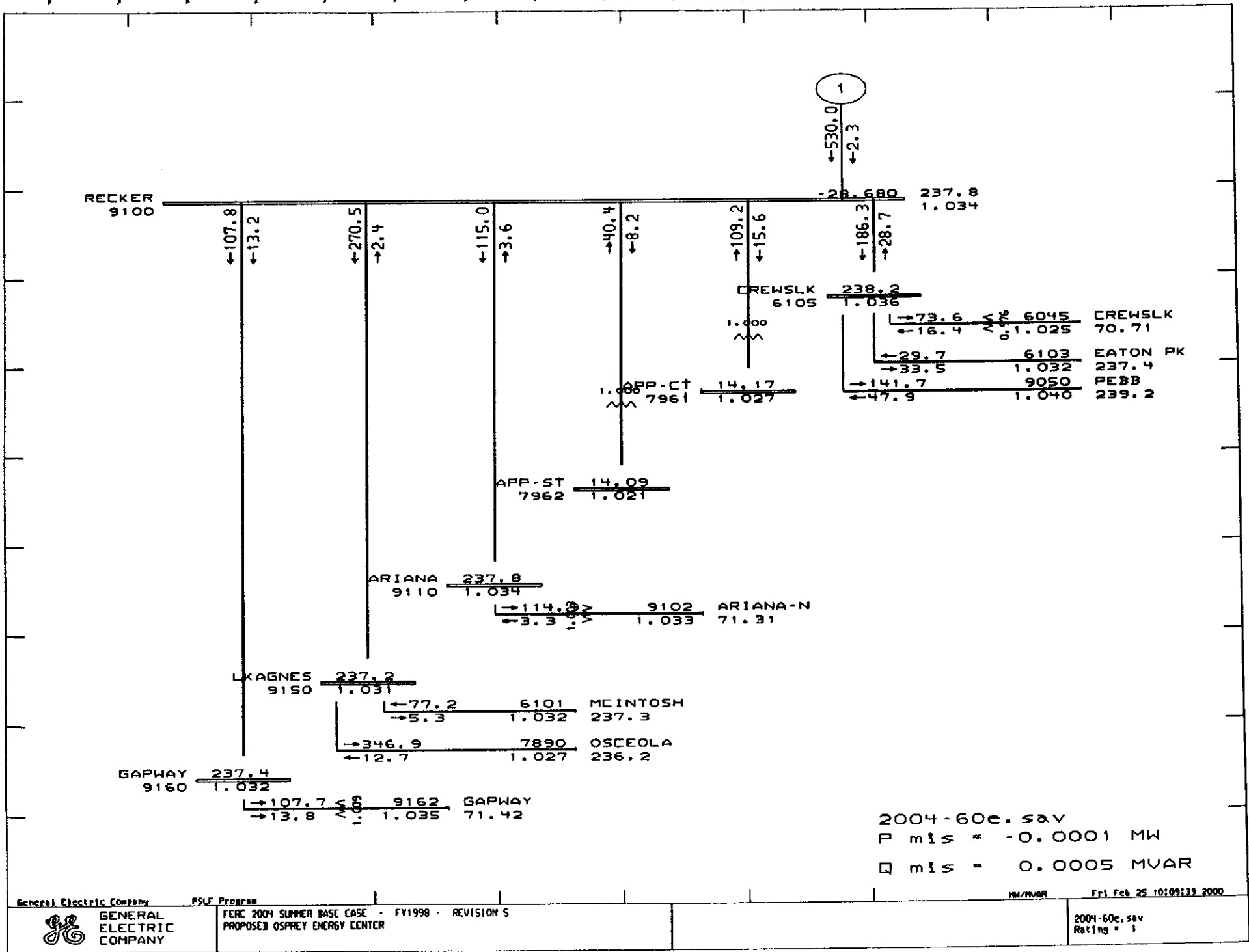

2004-60e.sav
 P mis = -0.0001 MW
 Q mis = 0.0005 MVAR

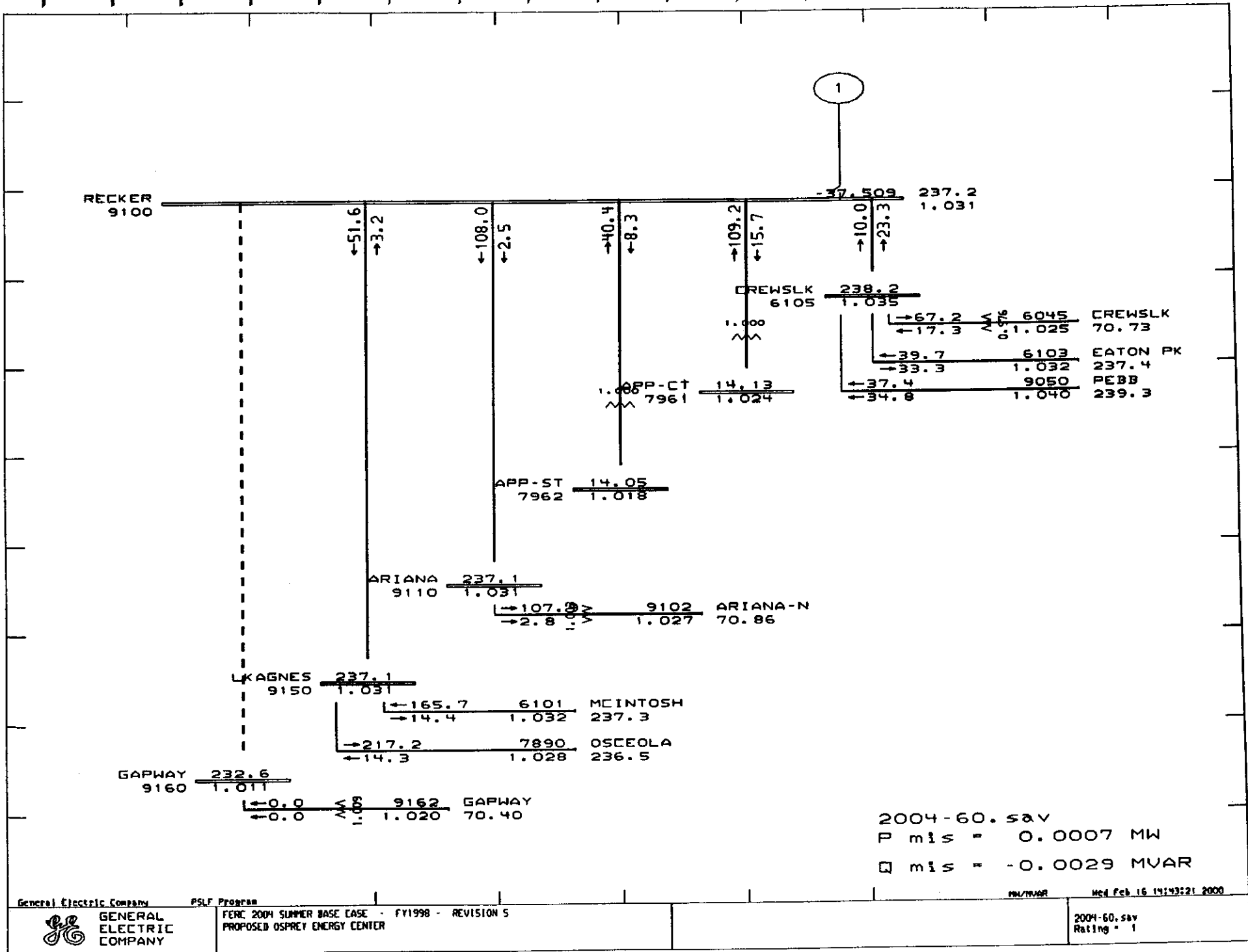

2004-60.sav
P mis = 0.0007 MW
Q mis = -0.0029 MVAR

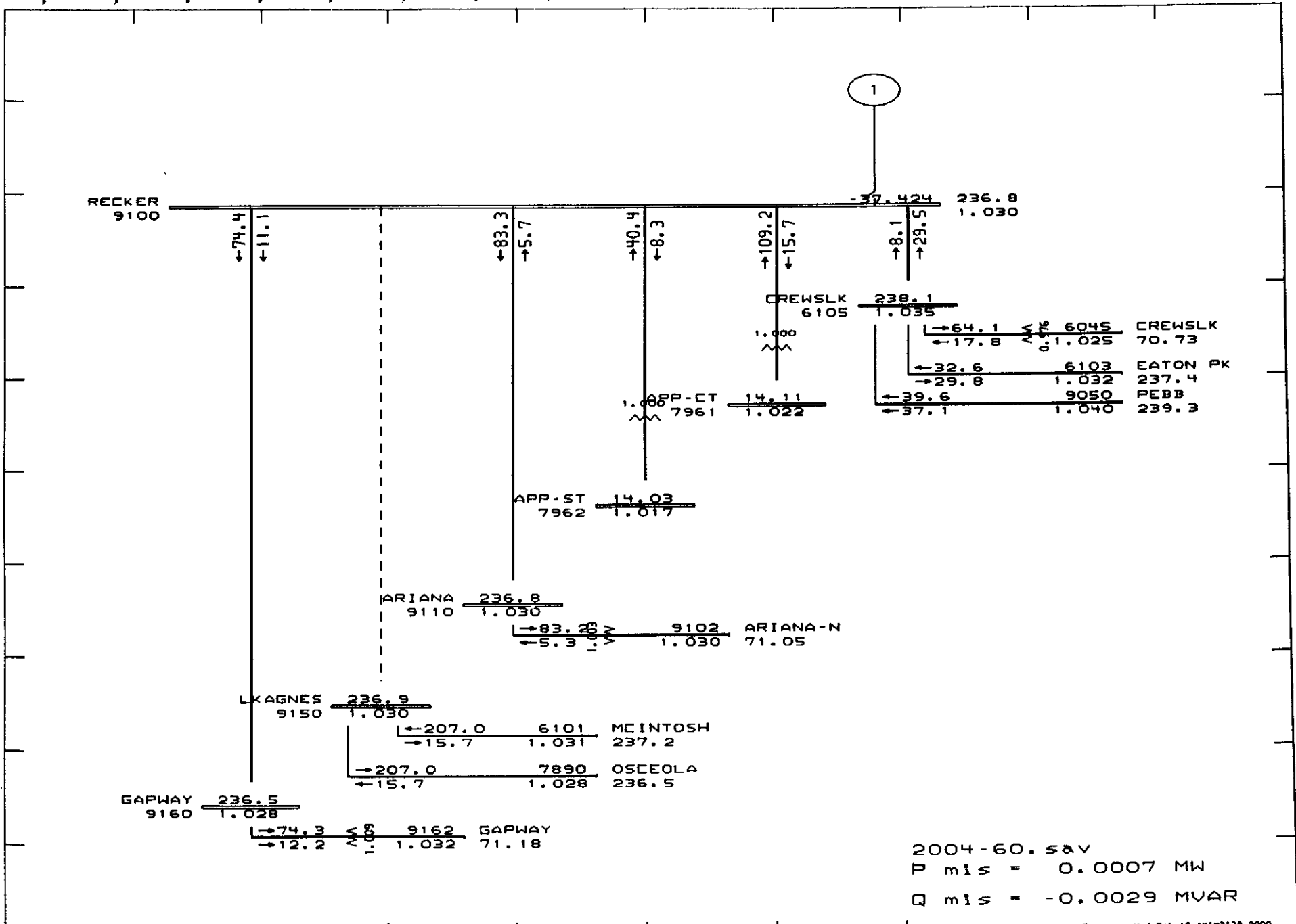

2004-60.sav
 P mis = 0.0007 MW
 Q mis = -0.0029 MVAR

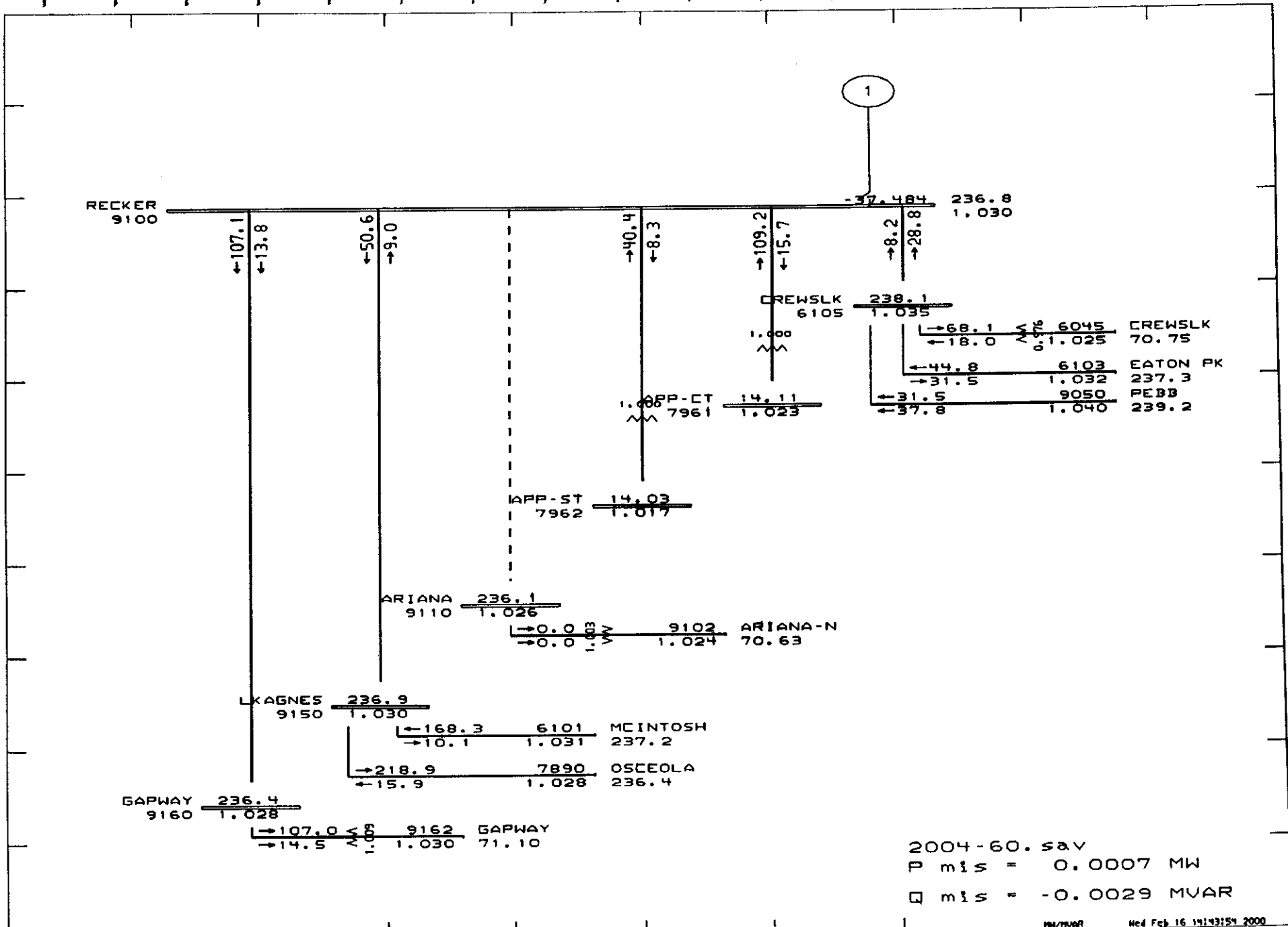

2004-60.sav
 P mis = 0.0007 MW
 Q mis = -0.0029 MVAR

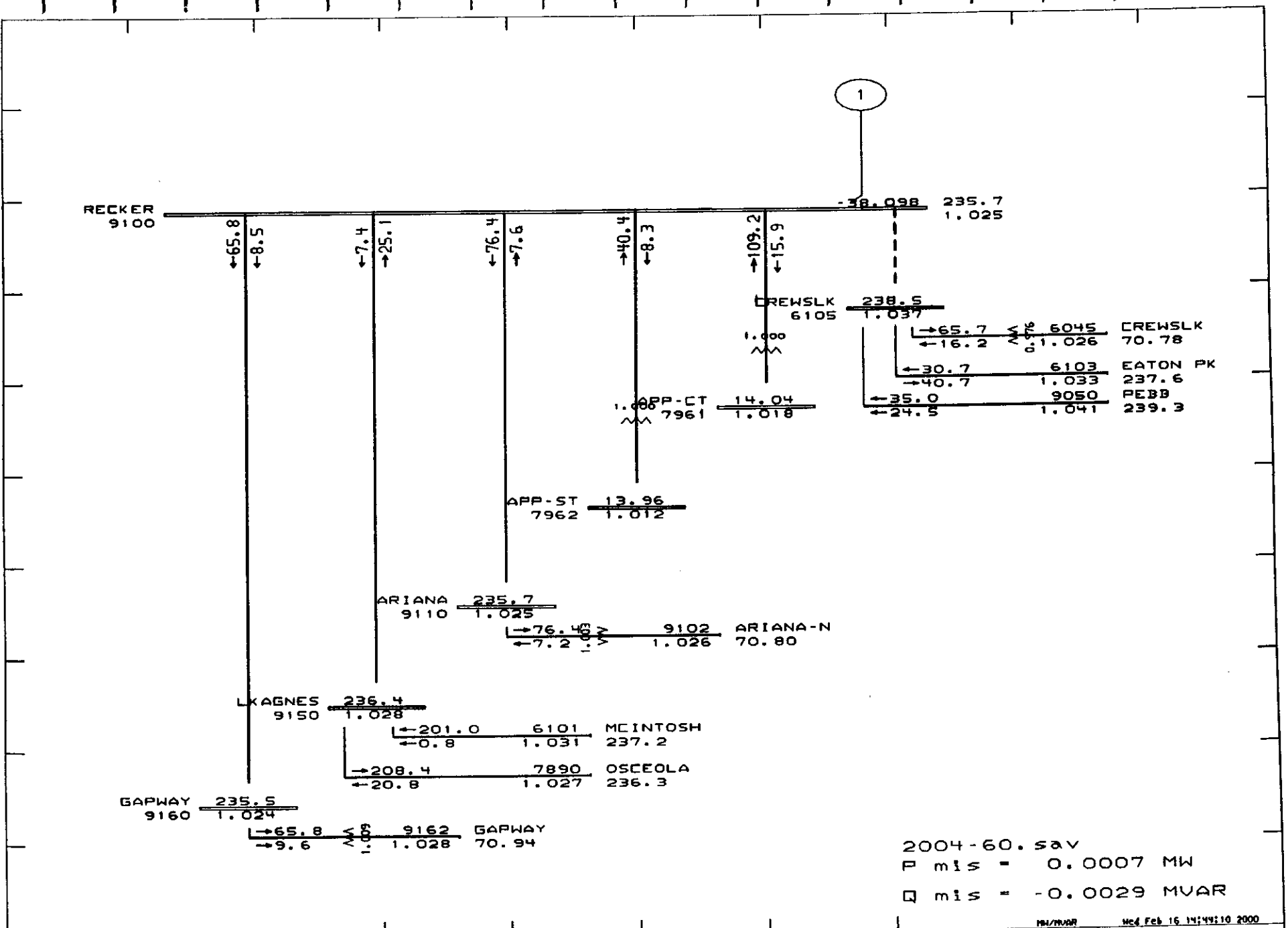

General Electric Company

PSLF Program

FERC 2004 SUMMER BASE CASE - FY1998 - REVISION 5
PROPOSED OSPREY ENERGY CENTER

MW/MVAR

Feb 16 11:49:10 2000



GENERAL
ELECTRIC
COMPANY

2004-60.sav
Rating = 1

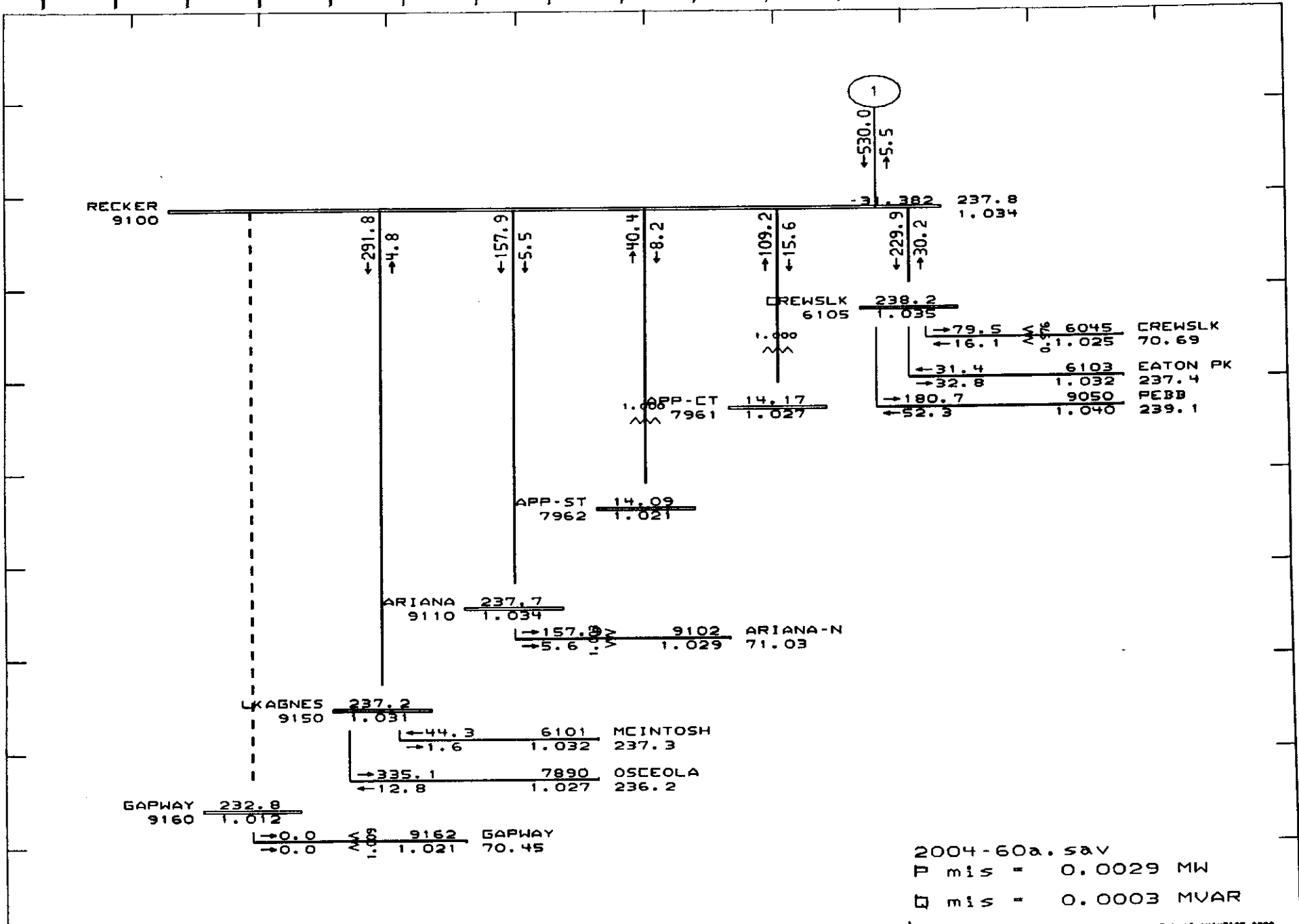

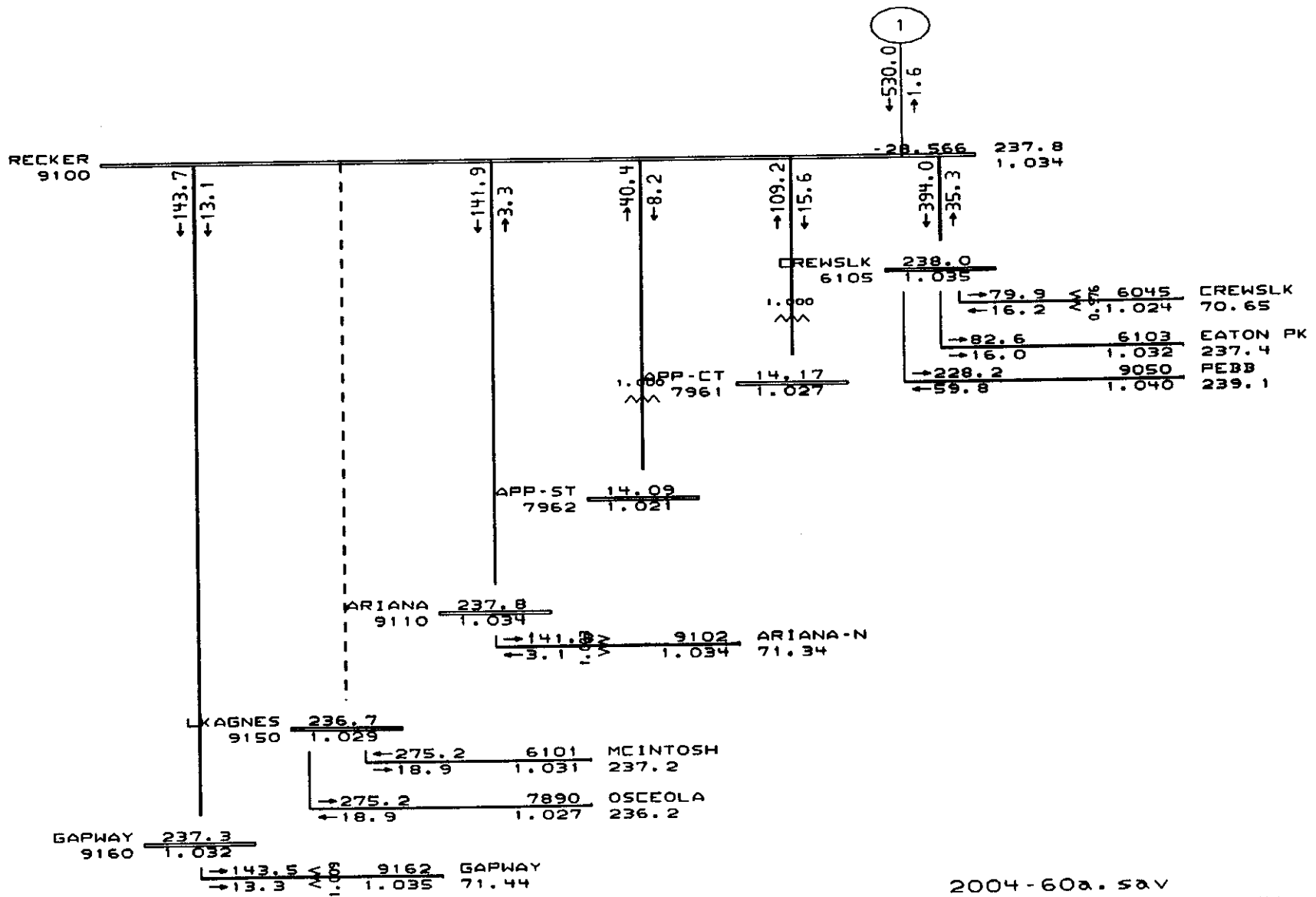

2004-60a.sav
 P mis = 0.0029 MW
 Q mis = 0.0003 MVAR

194/MVAR Wed Feb 16 14:45:36 2000



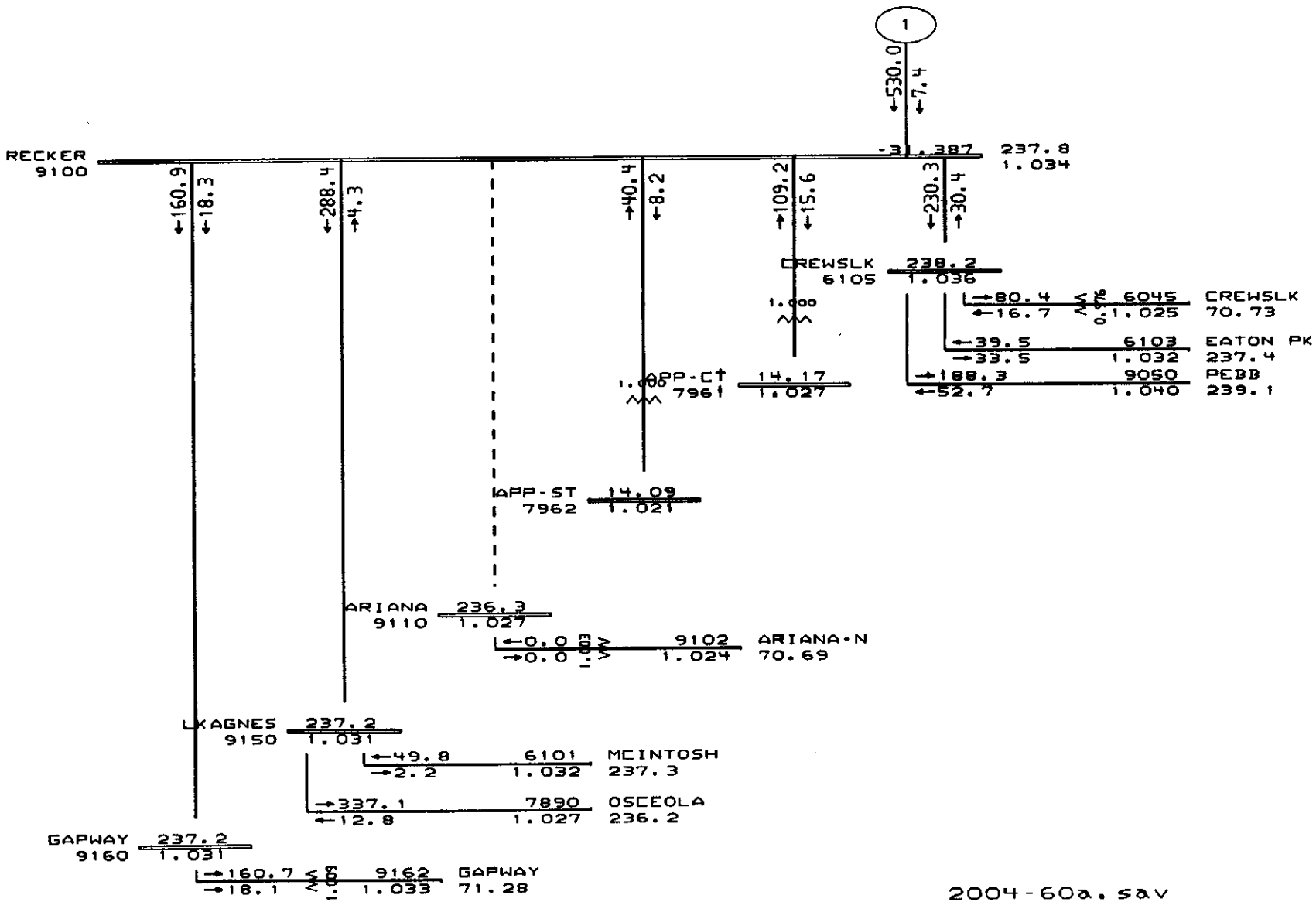

2004-60a.sav
 P mis = 0.0029 MW
 Q mis = 0.0003 MVAR

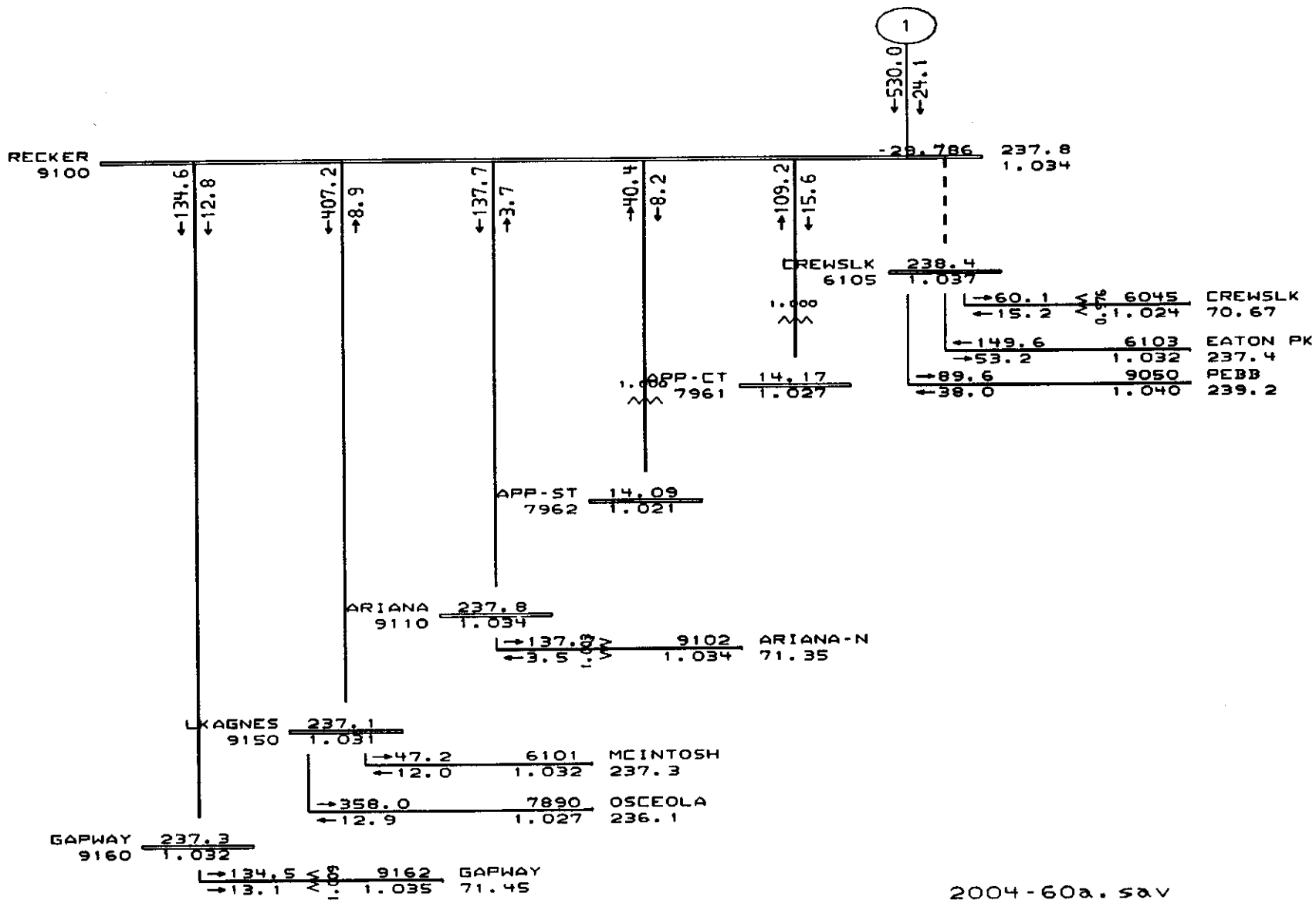

2004-60a.sav
 P mis = 0.0029 MW
 Q mis = 0.0003 MVAR

RECKER
9100

←296.5
→6.0

←157.1
→5.3

→40.4
→8.2

→109.2
→15.6

←530.0
→6.7

237.8
1.034

CREWSLK
6105

238.2
1.035

→79.9	6045	CREWSLK
←16.0	1.024	70.69
→11.9	6103	EATON PK
→30.6	1.032	237.4
→156.8	9050	PEBB
→49.5	1.040	239.1

APP-CT
7961

14.17
1.027

APP-ST
7962

14.09
1.021

ARIANA
9110

237.7
1.034

→157.6
→5.4

9102
1.030

ARIANA-N
71.04

LKAGNES
9150

237.2
1.031

←28.4
←0.1

6101
1.032

MEINTOSH
237.3

→323.9
→12.7

7890
1.027

OSCEOLA
236.3

GAPWAY
9160

232.8
1.012

→0.0
←0.0

9162
1.021

GAPWAY
70.46

2004-60b.sav

P mis = -0.0047 MW

Q mis = -0.0007 MVAR



RECKER
9100

←144.8

←13.1

←141.3

→3.5

→40.4

←8.2

→109.2

←15.6

1

←530.0

→1.7

←29.239

237.8

1.034

←393.4

→35.2

CREWSLK
6105

238.0

1.035

1.000

→80.4

←16.1

0.576

6045

CREWSLK
70.65

→104.5

←13.8

6103

EATON PK

237.4

→205.3

←87.5

9050

PEBB

239.1

APP-CT
7961

14.17

1.027

APP-ST
7962

14.09

1.021

ARIANA
9110

237.8

1.034

→141.3

←3.4

1.034

9102

ARIANA-N
71.35

LKAGNES
9150

236.7

1.029

←263.1

18.2

6101

MCINTOSH

237.2

→263.1

18.2

7890

OSCEOLA

236.3

GAPWAY
9160

237.3

1.032

→144.6

←13.2

1.035

9162

GAPWAY

71.45

2004-60b.sav

P mis = -0.0047 MW

Q mis = -0.0007 MVAR

General Electric Company

PSLF Program

FERC 2004 SUMMER BASE CASE - FY1998 - REVISION 5
PROPOSED OSPREY ENERGY CENTER

NM/MVAR

Wed Feb 16 14:46:57 2000



GENERAL
ELECTRIC
COMPANY

2004-60b.sav
Rating = 1

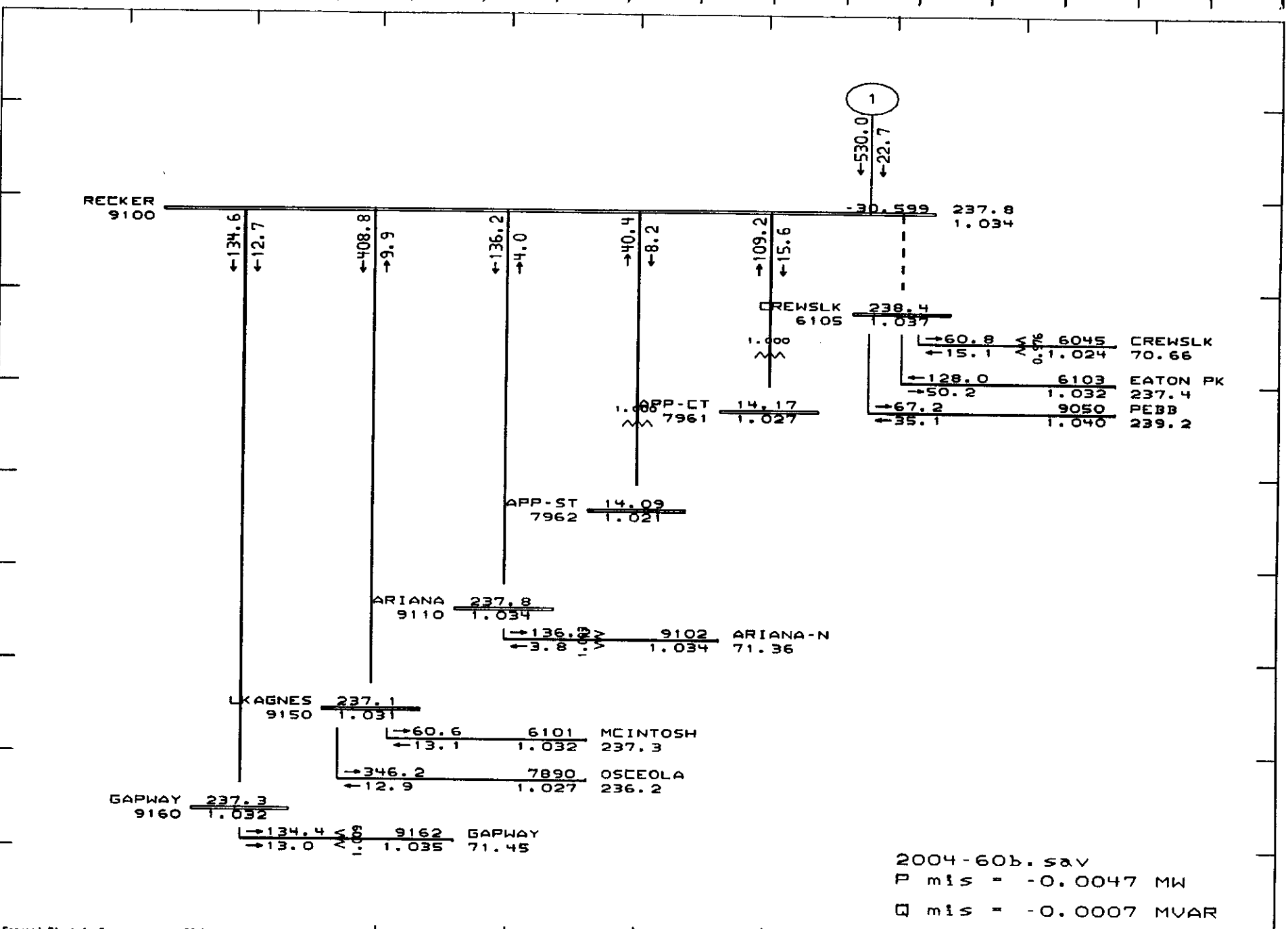

2004-60b.sav
P mis = -0.0047 MW
Q mis = -0.0007 MVAR

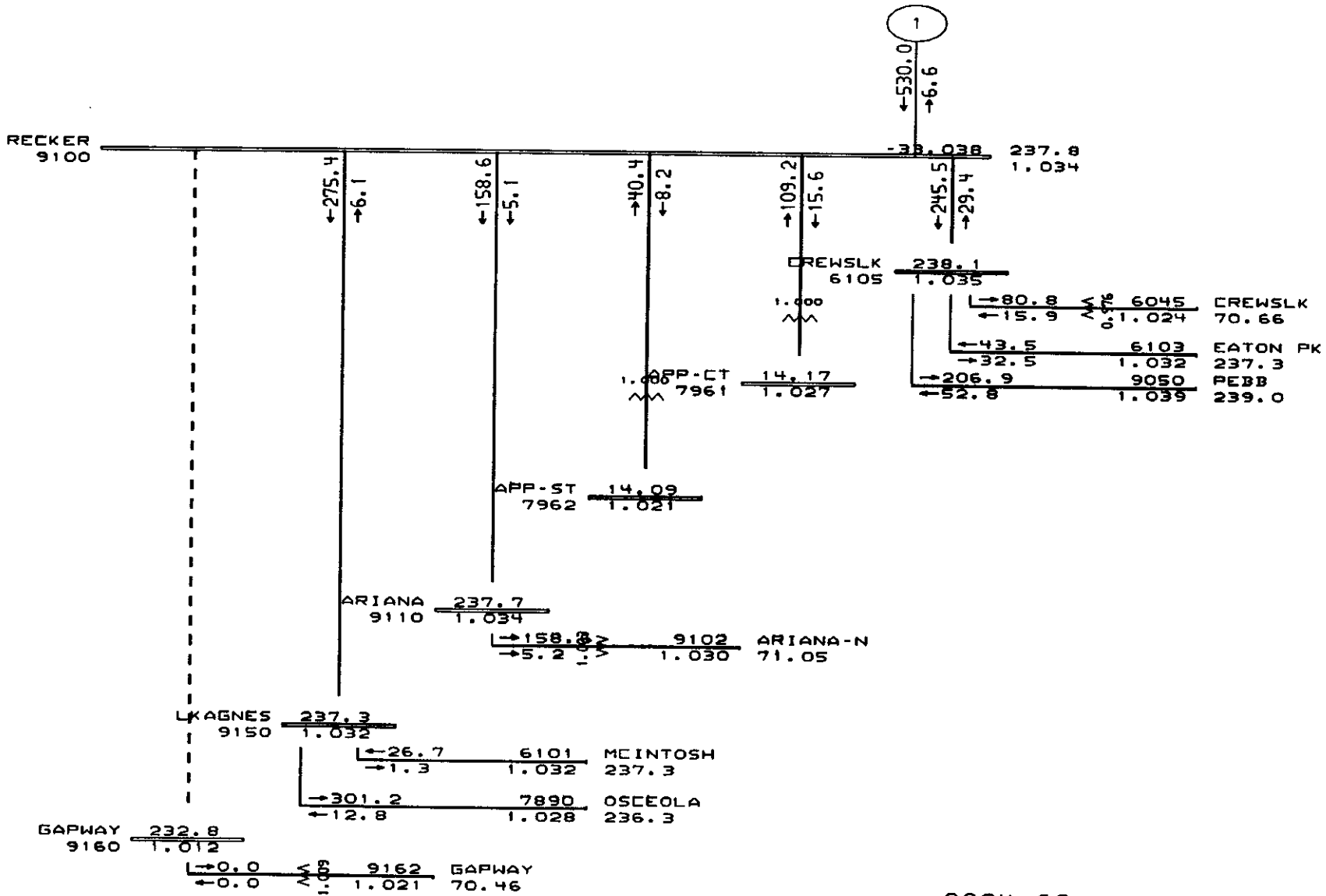

2004-60c.sav
 P mis = -0.0004 MW
 Q mis = -0.0020 MVAR

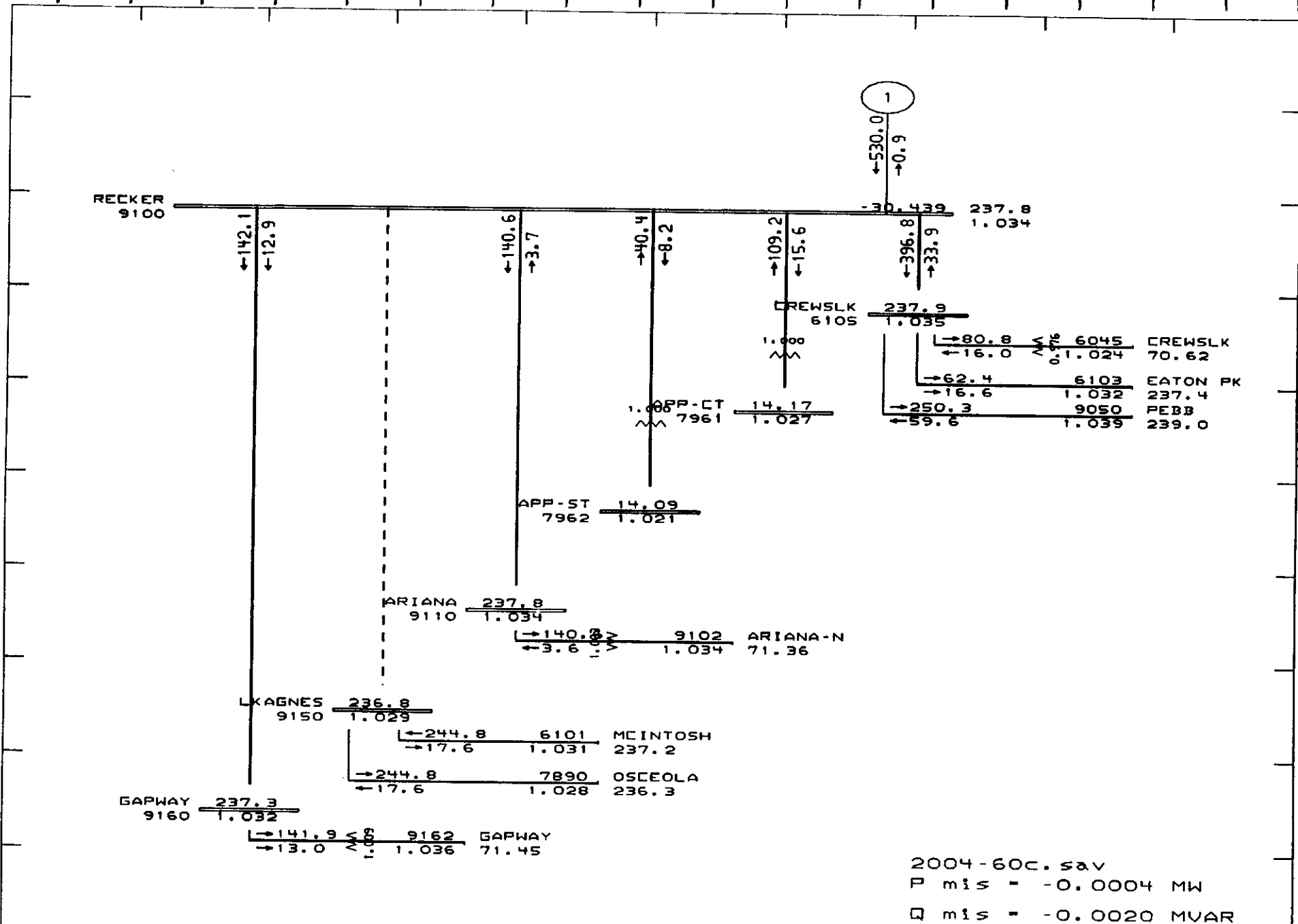

2004-60c.sav
 P mis = -0.0004 MW
 Q mis = -0.0020 MVAR

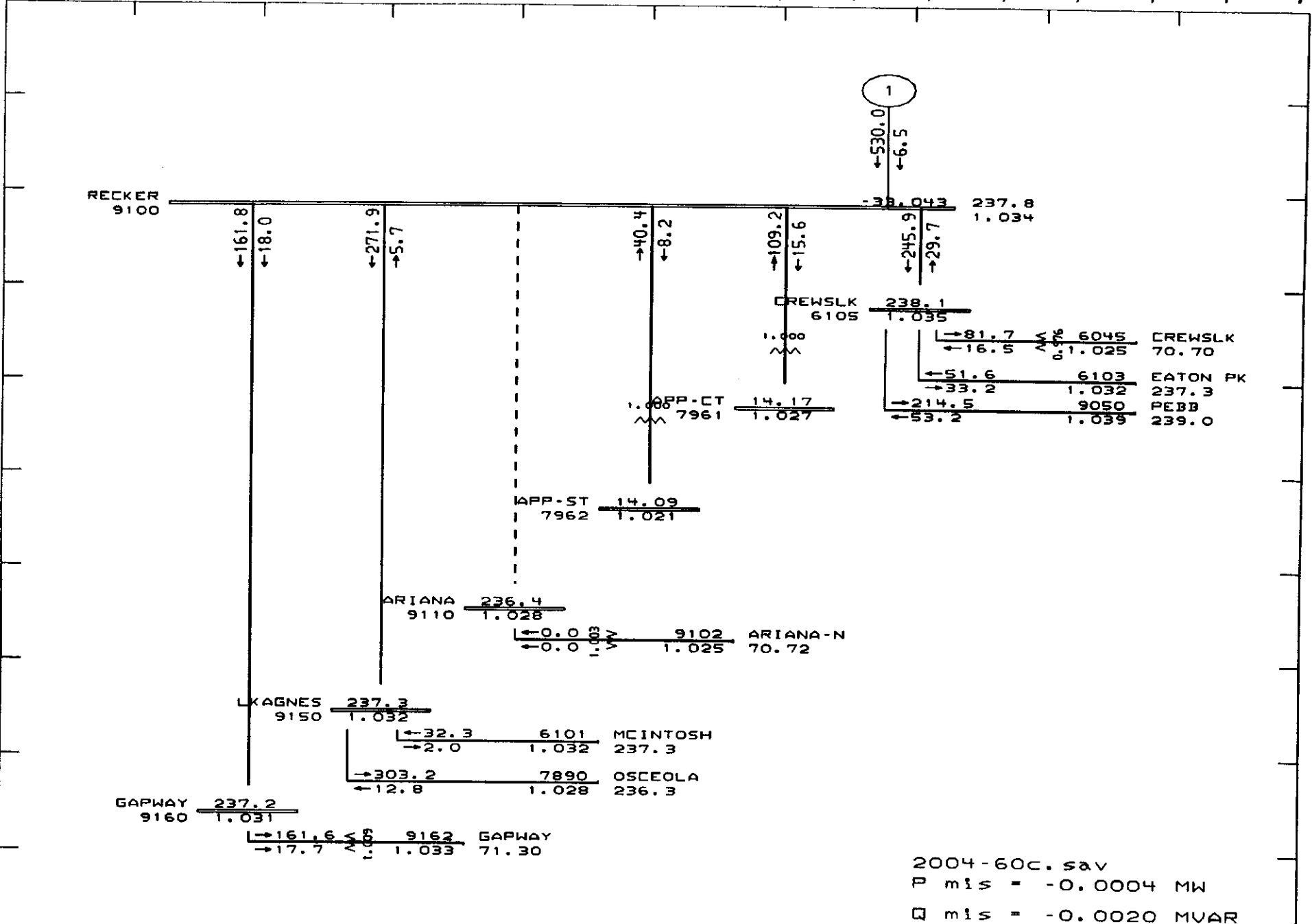

2004-60c.sav
P mis = -0.0004 MW
Q mis = -0.0020 MVAR

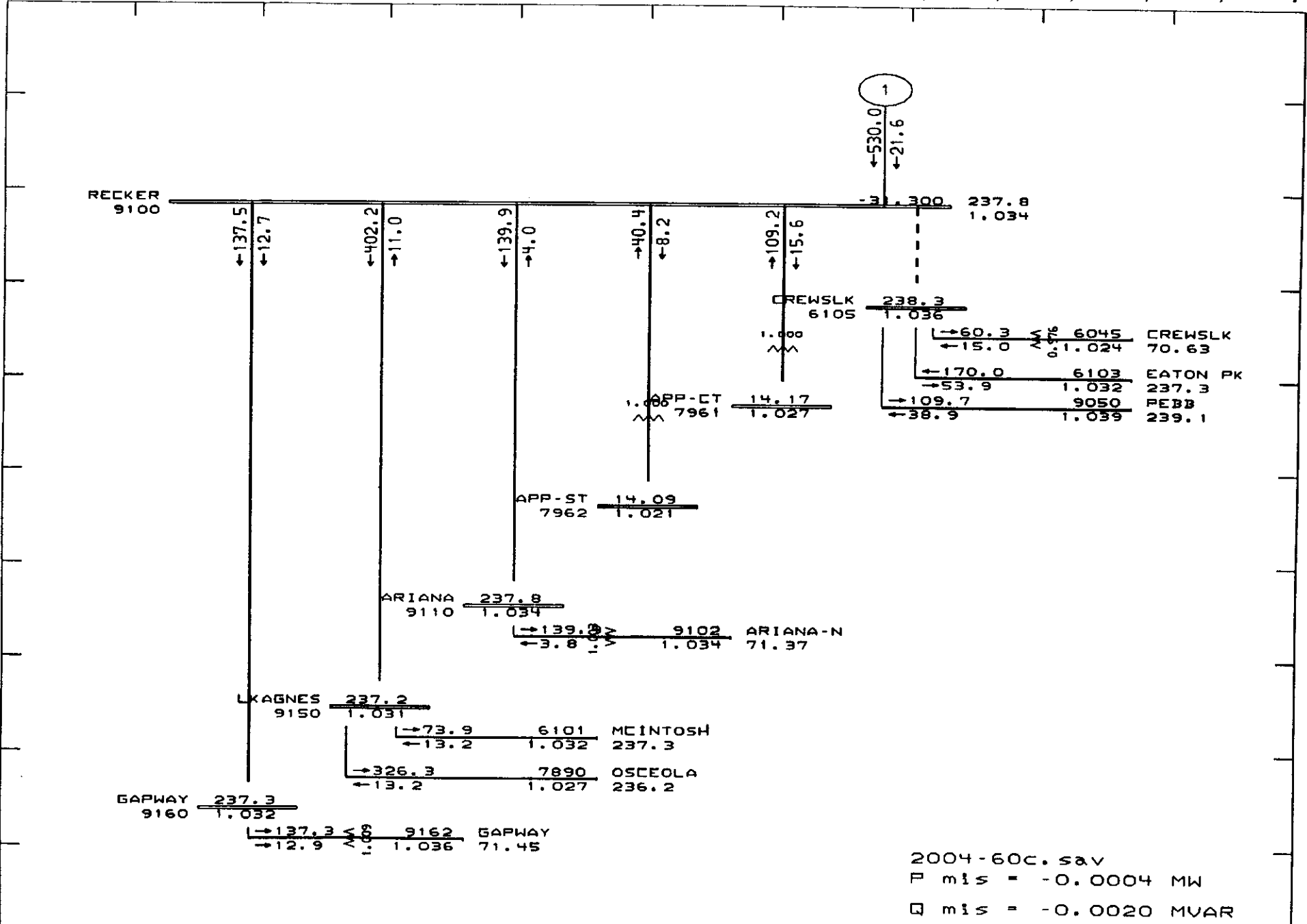

2004-60c.sav
 P mis = -0.0004 MW
 Q mis = -0.0020 MVAR

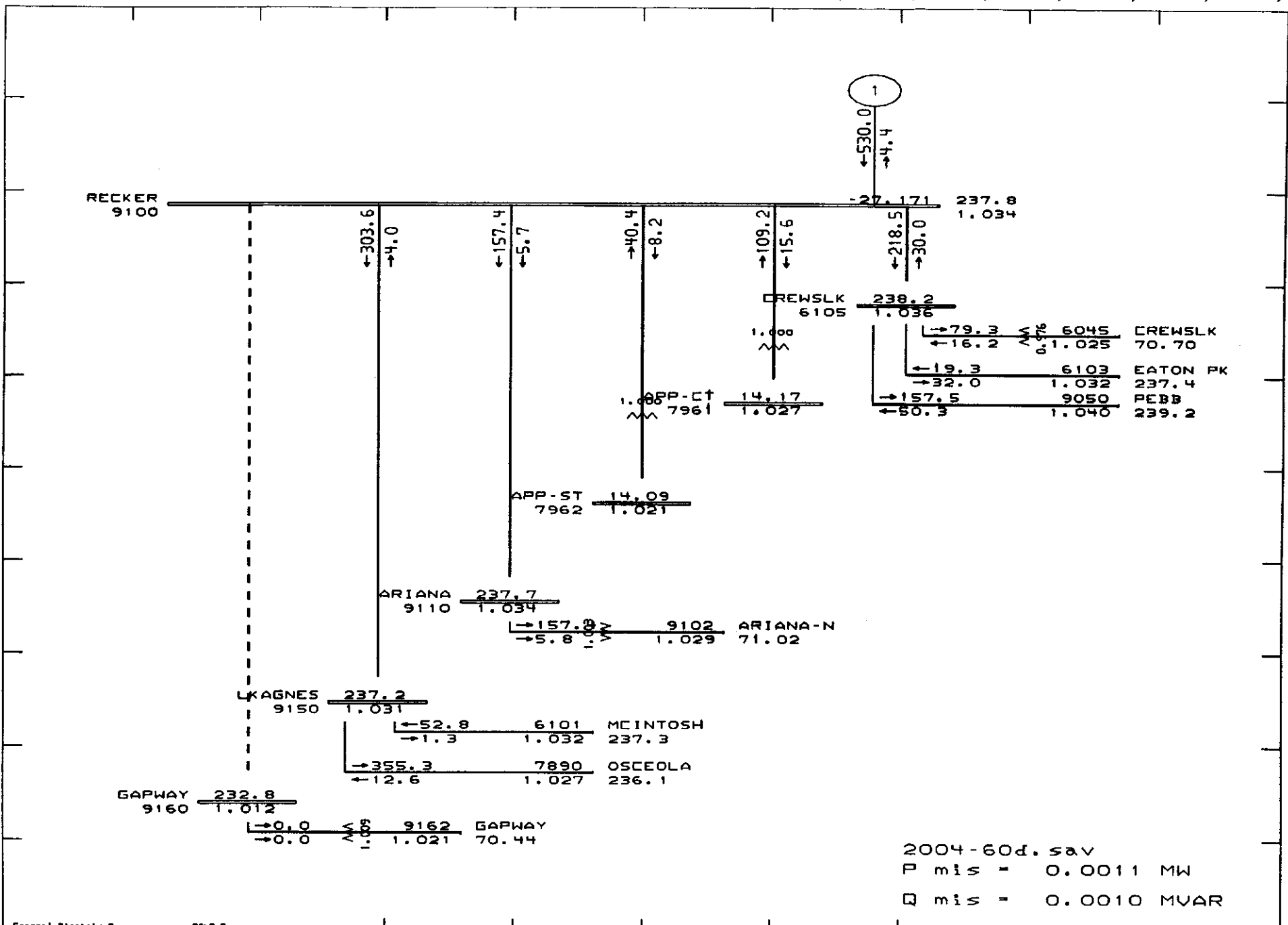

2004-60d.sav
 P mis = 0.0011 MW
 Q mis = 0.0010 MVAR

RECKER
9100

←145.0

←13.3

←142.7

→3.0

→40.4

←8.2

→109.2

←15.6

←530.0
→1.5

237.8
1.034

CREWSLK
6105

238.0
1.035

→90.0
←16.2

6045
0.1.024

CREWSLK
70.66

→100.6
←14.6

6103
1.032

EATON PK
237.4

→208.0
←58.4

9050
1.040

PEBB
239.1

APP-ET
7961

14.17
1.027

APP-ST
7962

14.09
1.021

ARIANA
9110

237.8
1.034

→142.8
←2.9

9102
1.034

ARIANA-N
71.33

LKAGNES
9150

236.6
1.029

→292.8
→19.5

6101
1.031

MCINTOSH
237.2

→292.8
←19.5

7890
1.027

OSCEOLA
236.2

GAPWAY
9160

237.3
1.032

→144.8
→13.4

9162
1.035

GAPWAY
71.44

2004-60d.sav

P mis = 0.0011 MW

Q mis = 0.0010 MVAR

General Electric Company

PSLF Program

FERC 2004 SUMMER BASE CASE - FY1998 - REVISION 5
PROPOSED OSPREY ENERGY CENTER

MW/MVAR

Mod Feb 16 14:49:50 2000



GENERAL
ELECTRIC
COMPANY

2004-60d.sav
Rating = 1

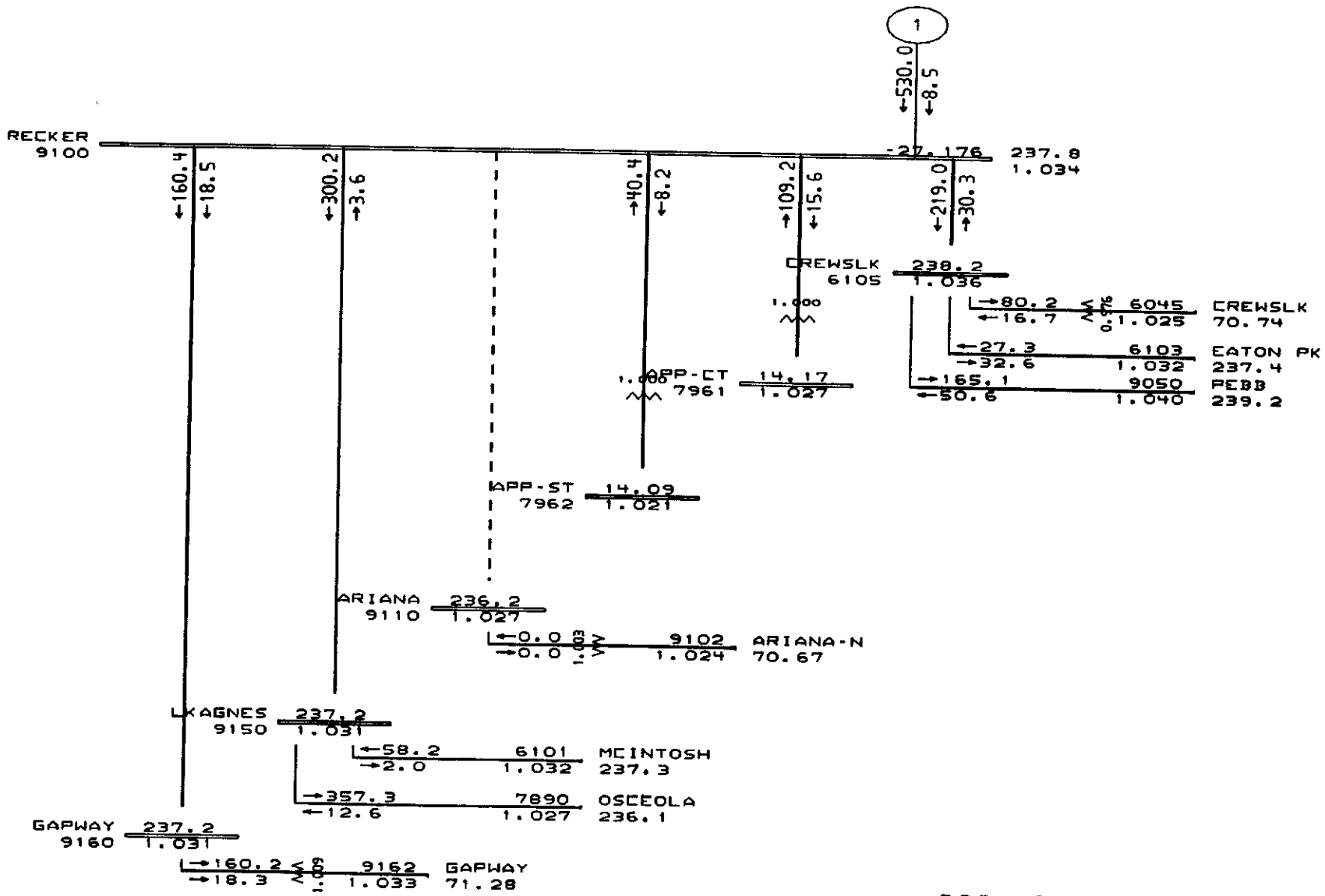

2004-60d.sav
P mis = 0.0011 MW
Q mis = 0.0010 MVAR

General Electric Company PSLF Program



FERC 2004 SUMMER BASE CASE - FY1998 - REVISION 5
PROPOSED OSPREY ENERGY CENTER

MLT/MAR Wed Feb 16 15:12:36 2000

2004-60d.sav
Rating = 1

RECKER
9100

←132.8

←12.9

←410.7

→7.7

←136.1

→3.6

→40.4

←8.2

→109.2

←15.6

1

←530.0

←25.6

25.680

237.8
1.034

CREWSLK
6105

238.4
1.037

1.000
^^

→60.7
←15.3

6045
0.576
1.024

CREWSLK
70.68

←131.5
→51.3

6103
1.032

EATON PK
237.4

→70.8
←36.0

9050
1.040

PEBB
239.2

1.066
^^
APP-CT
7961

14.17
1.027

APP-ST
7962

14.09
1.021

ARIANA
9110

237.8
1.034

→136.8
←3.4

1.000
^^
9102
1.034

ARIANA-N
71.34

LXAGNES
9150

237.1
1.031

→32.0
←11.4

6101
1.032

MCINTOSH
237.3

→376.6
←12.5

7890
1.026

OSCEOLA
236.0

GAPWAY
9160

237.3
1.032

→132.7
←13.2

1.000
^^
9162
1.035

GAPWAY
71.44

2004-60d.sav

P mis = 0.0011 MW

Q mis = 0.0010 MVAR

General Electric Company PSLF Program



GENERAL
ELECTRIC
COMPANY

FERC 2004 SUMMER BASE CASE - FY1998 - REVISION 5
PROPOSED OSPREY ENERGY CENTER

PSL/MVAR

Wed Feb 16 14:50:17 2000

2004-60d.sav
Rating = 1

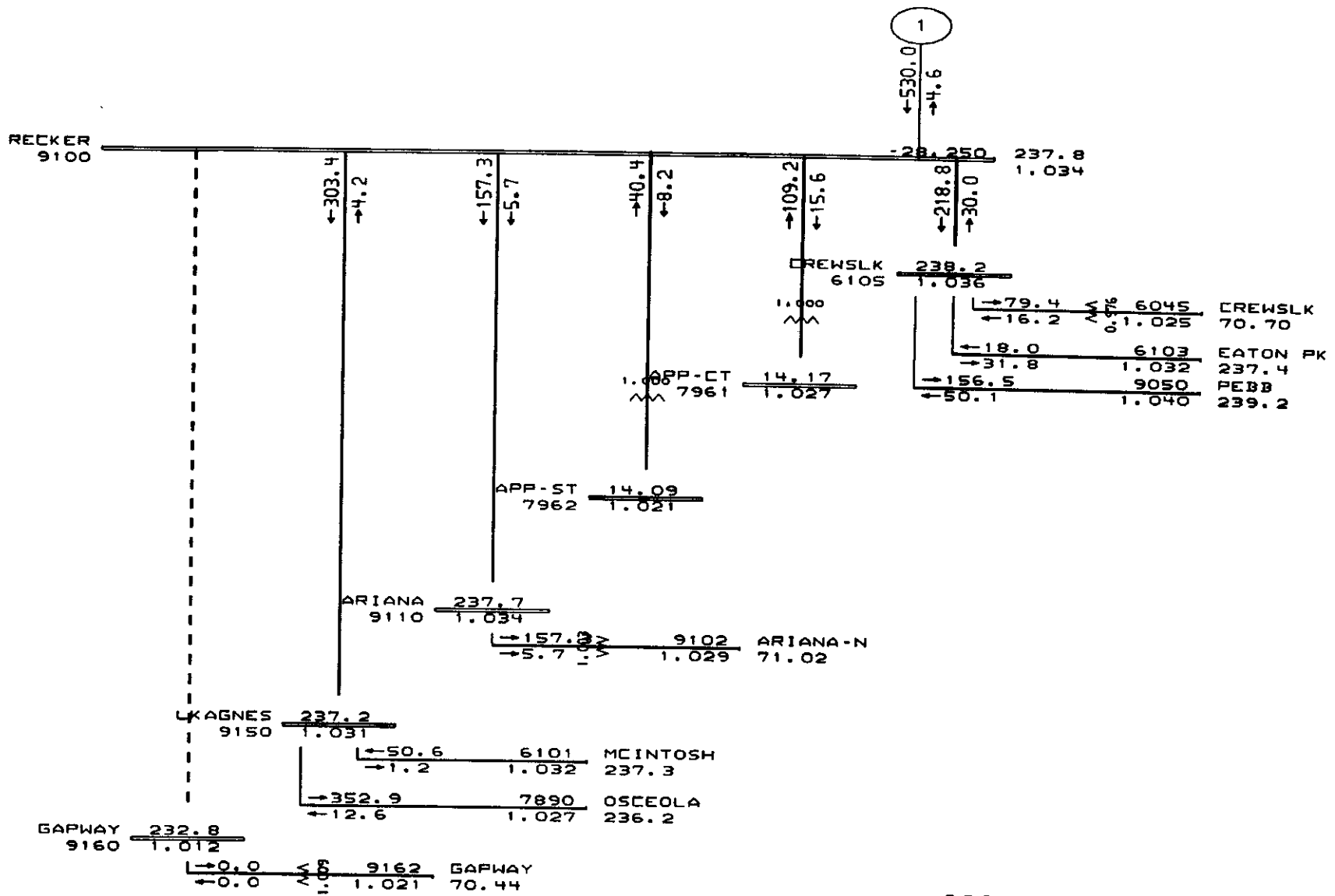

2004-60e.sav
P mis = -0.0001 MW
Q mis = 0.0005 MVAR

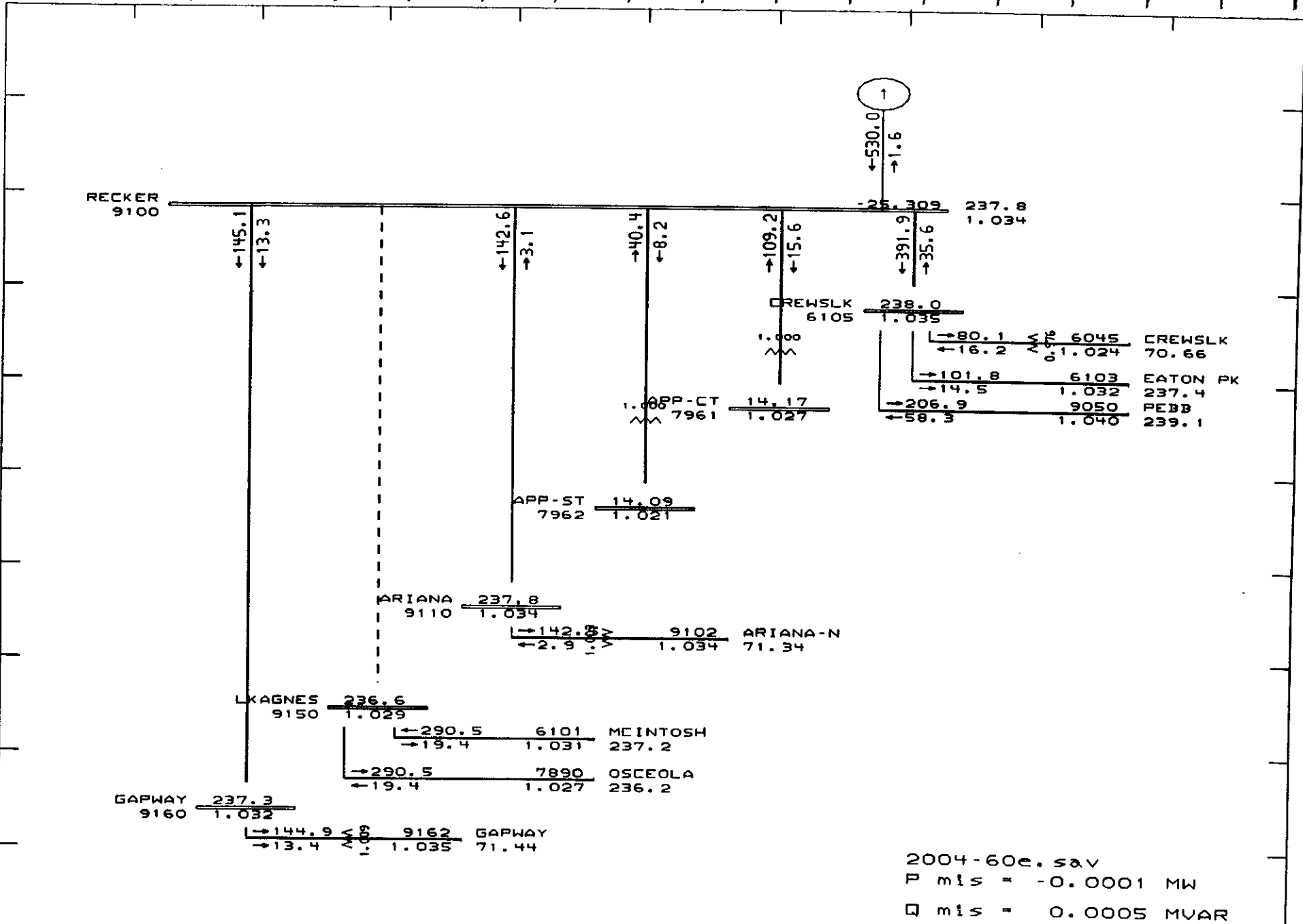

2004-60e.sav
 P mis = -0.0001 MW
 Q mis = 0.0005 MVAR

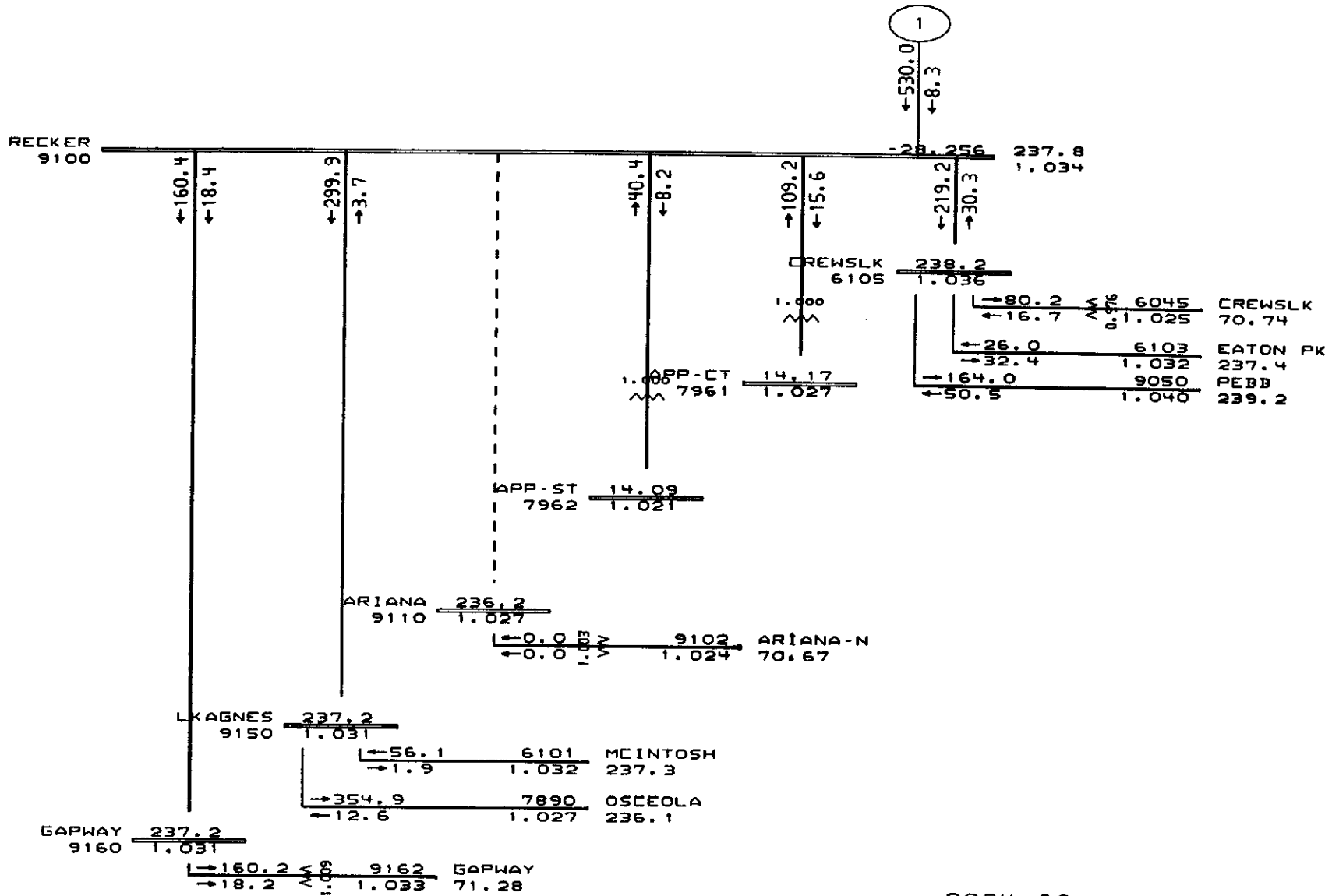

2004-60e.sav
 P mis = -0.0001 MW
 Q mis = 0.0005 MVAR

RECKER
9100

←132.9

←12.9

←410.6

→7.8

←136.0

→3.6

→40.4

←8.2

→109.2

←15.6

1

←530.0

←25.3

→26.756

237.8
1.034

CREWSLK
6105

→238.4
1.037

1.000

→60.7
←15.2

0.976

6045

CREWSLK
70.68

→130.3
→51.1

1.032

6103
EATON PK
237.4

→69.7
←55.9

1.040

9050
PEBB
239.2

1.000
APP-CT
7961

→14.17
1.027

APP-ST
7962

→14.09
1.021

ARIANA
9110

→237.8
1.034

→136.8
←3.4

1.034

9102
ARIANA-N
71.34

LKAGNES
9150

→237.1
1.031

→34.3
←11.5

1.032

6101
MCINTOSH
237.3

→374.3
←12.6

1.026

7890
OSCEOLA
236.1

GAPWAY
9160

→237.3
1.032

→132.8
→13.2

1.035

9162
GAPWAY
71.44

2004-60e.sav

P mis = -0.0001 MW

Q mis = 0.0005 MVAR

General Electric Company

PSLF Program

FERC 2004 SUMMER BASE CASE - FY1998 - REVISION 5
PROPOSED OSPREY ENERGY CENTER

PM/MVAR

Wed Feb 16 14:51:29 2000



GENERAL
ELECTRIC
COMPANY

2004-60e.sav
Rating = 1

APPENDIX IV

Base Case Flows on Constrained Paths

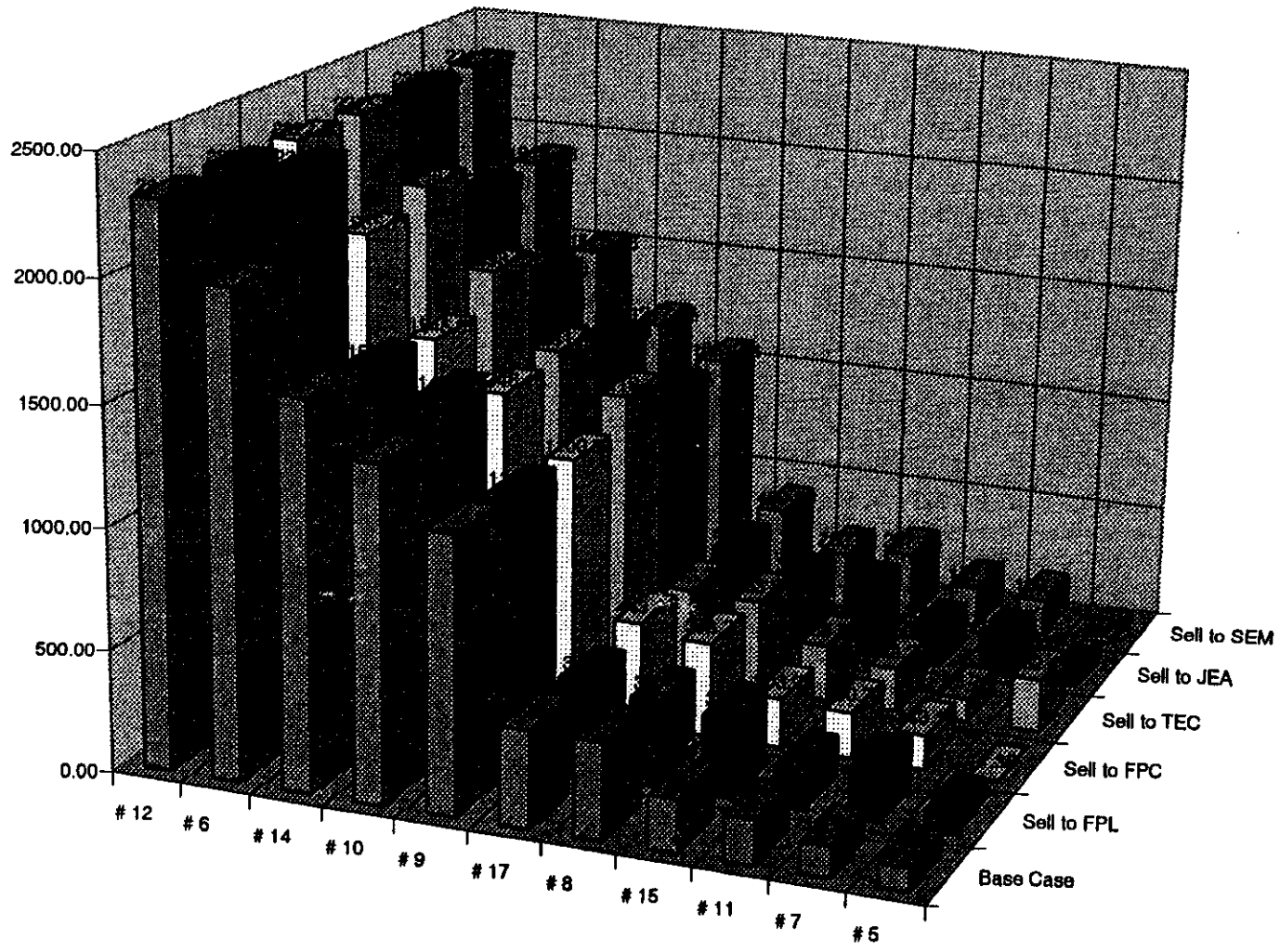

2004 Case - 100% Load

Base Case Flows on Constrained Paths

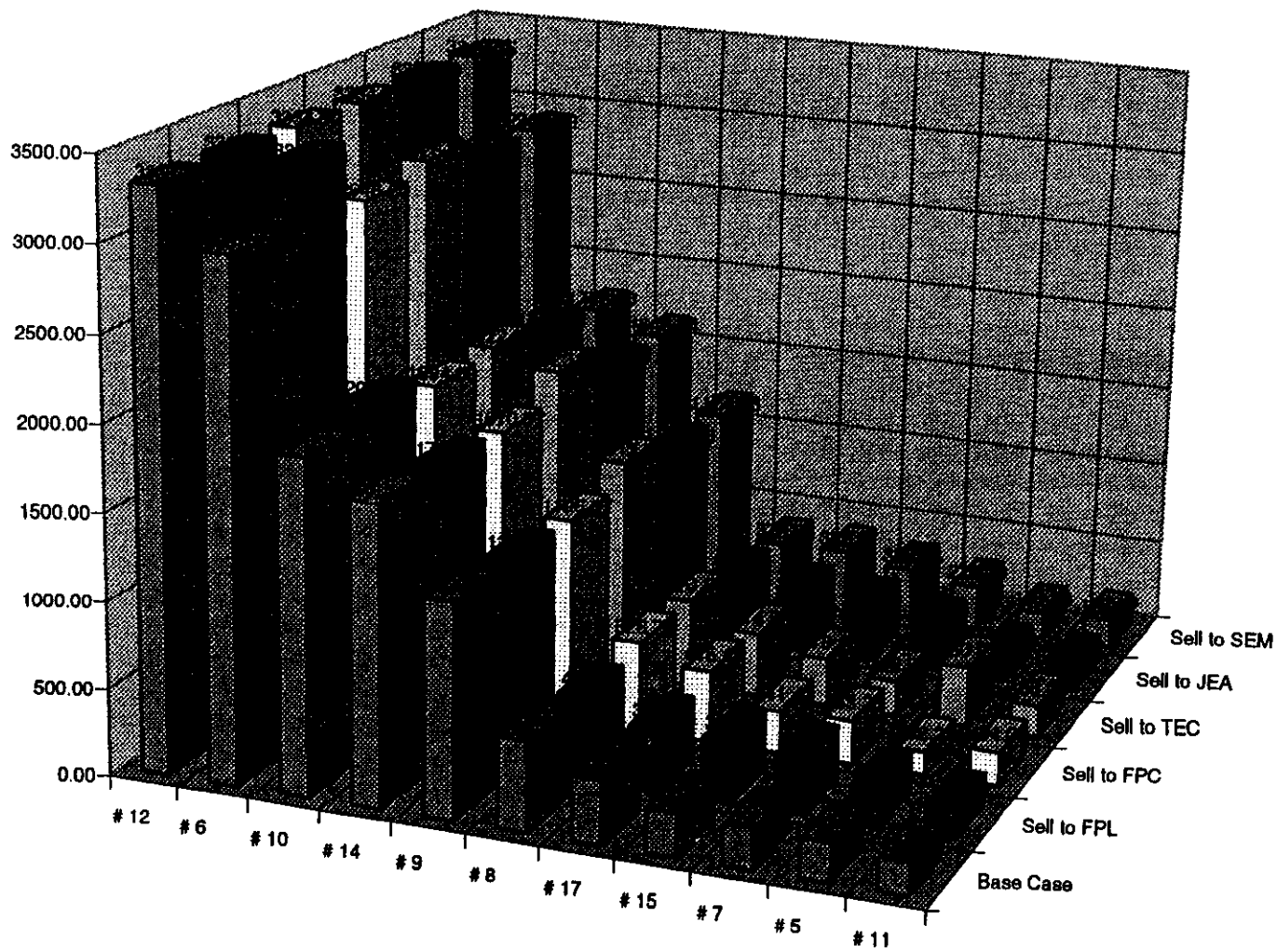

2004PI Case - 100% Load

Base Case Flows on Constrained Paths

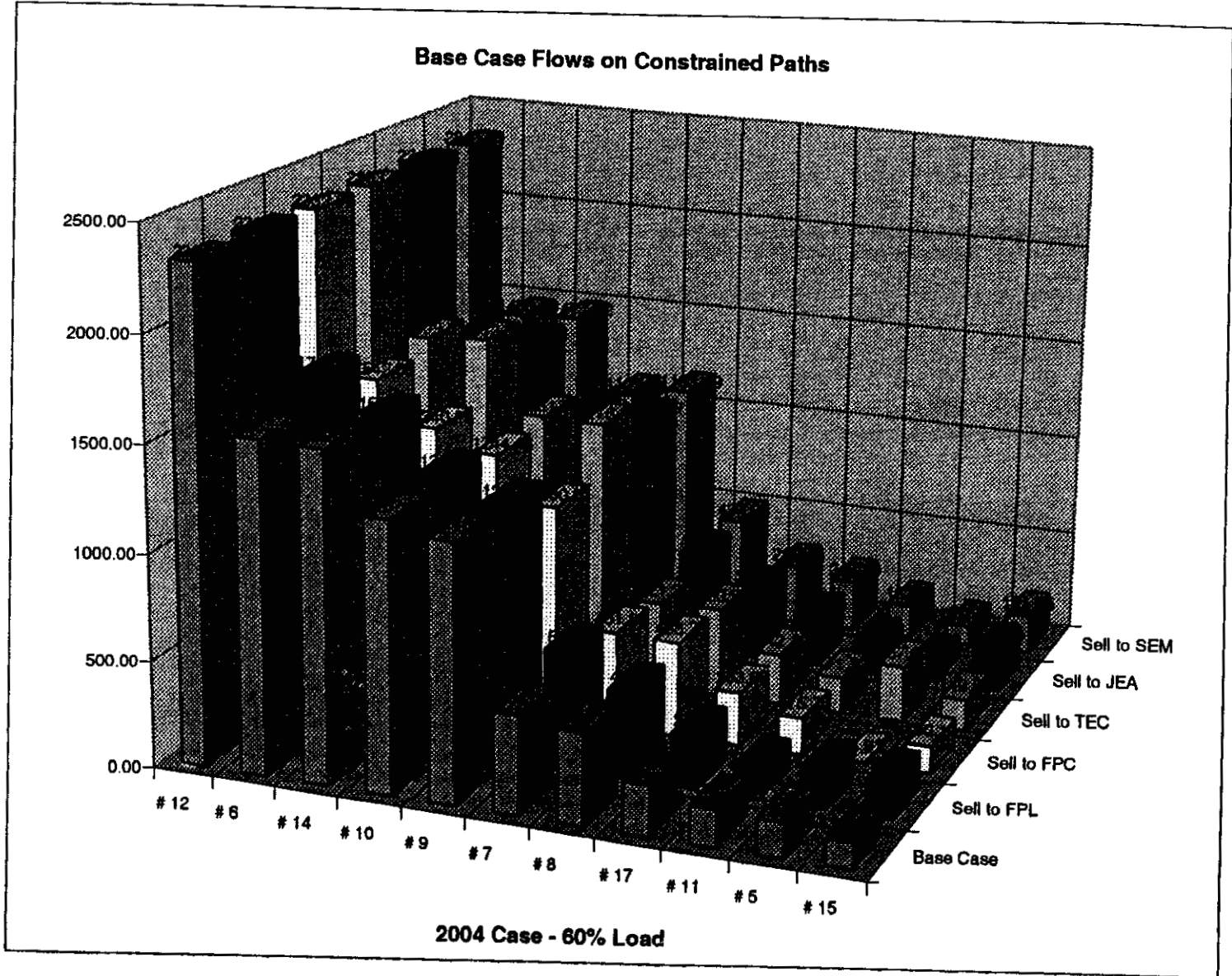

2004 Case - 60% Load

Table 1
Summary of Constrained Paths
in Base Case & OEC Alternatives

	Case 2004	OEC Sell 500 MW to :				
	Base Case	Case 2004A Sell to FPL	Case 2004B Sell to FPC	Case 2004C Sell to TEC	Case 2004D Sell to JEA	Case 2004E Sell to SEM
# 12	2314.17	2320.28	2322.50	2325.21	2330.50	2332.42
# 6	1997.09	2344.98	1955.11	2038.61	1903.84	1912.43
# 14	1596.51	1578.06	1545.64	1698.67	1535.50	1526.48
# 10	1373.65	1483.49	1348.16	1381.96	1273.29	1217.95
# 9	1136.02	1121.98	1100.54	1219.46	1088.65	1081.64
# 17	395.20	391.21	443.31	402.78	406.67	409.93
# 8	391.70	350.70	398.20	393.24	300.83	250.92
# 15	215.94	328.18	203.94	238.97	303.16	287.24
# 11	184.08	169.91	190.72	182.29	164.78	172.71
# 7	128.19	204.39	143.14	93.76	164.33	160.21
# 5	94.52	86.08	1.38	222.41	40.76	31.62

Table 2
Summary of Constrained Paths
in Base Case & OEC Alternatives

	OEC Sell 500 MW to :					
	Case 2004PI	Case 2004PIA	Case 2004PIB	Case 2004PIC	Case 2004PID	Case 2004PIE
	Base Case	Sell to FPL	Sell to FPC	Sell to TEC	Sell to JEA	Sell to SEM
# 12	3328.22	3333.06	3334.80	3334.25	3337.70	3343.05
# 6	2985.61	3332.69	2946.20	3026.09	2898.11	2905.90
# 10	1916.15	2008.69	1894.00	1922.86	1830.74	1772.86
# 14	1718.75	1706.43	1670.07	1822.92	1655.43	1646.84
# 9	1229.97	1220.86	1196.37	1313.92	1181.00	1174.06
# 8	519.82	483.65	525.76	520.56	423.80	373.66
# 17	367.14	363.04	415.41	374.06	378.78	382.17
# 15	253.01	357.05	241.41	278.43	341.67	325.34
# 7	239.25	323.59	253.35	205.55	274.10	270.26
# 5	222.42	220.80	132.21	350.91	167.19	158.60
# 11	188.06	174.06	194.39	186.00	168.72	176.32

Table 3
Summary of Constrained Paths
in Base Case & OEC Alternatives

	OEC Sell 500 MW to :					
	Case 2004-60	Case 2004-60A	Case 2004-60B	Case 2004-60C	Case 2004-60D	Case 2004-60E
	Base Case	Sell to FPL	Sell to FPC	Sell to TEC	Sell to JEA	Sell to SEM
# 12	2324.79	2336.76	2332.36	2333.64	2341.56	2341.01
# 6	1554.62	1705.13	1542.08	1609.81	1458.73	1466.53
# 14	1549.13	1549.36	1340.28	1632.35	1485.41	1477.82
# 10	1267.60	1313.02	1244.46	1281.31	1169.55	1109.54
# 9	1208.88	1209.82	1030.01	1276.56	1159.69	1153.29
# 7	464.02	560.89	461.34	421.32	497.47	494.05
# 8	432.14	412.76	453.71	430.39	341.46	289.45
# 17	236.16	251.67	253.68	242.40	246.50	249.80
# 11	174.03	144.22	175.70	171.52	154.69	162.51
# 5	161.86	174.15	5.91	267.02	105.74	97.97
# 15	122.54	179.14	130.19	149.89	207.59	191.95

**ANALYSIS OF TRANSMISSION SYSTEM
IMPROVEMENTS IN SUPPORT OF OSPREY
ENERGY CENTER**

APRIL 18, 2000

Prepared For

CALPINE EASTERN CORPORATION

UNPUBLISHED WORK © APRIL 2000



Navigant



April 18, 2000

Mr. Paul A. Barnett
Calpine Eastern Corporation
The Pilot House, Lewis Wharf
Boston, MA 02110

Subject: Final Report on Transmission System Upgrade Study for Osprey Energy Center

Dear Mr. Barnett:

Enclosed are three copies of the final report on the transmission system upgrade study performed by Navigant Consulting, Inc. (Navigant Consulting) for the Osprey Energy Center. As we discussed last week, the transmission lines impacted will need to be rebuilt using stronger single pole, spun concrete structures to support the larger conductors required to increase line capacity. Calculations performed to make this determination and associated construction cost estimates are included in the report.

Three technically feasible options emerged for increasing the capacity of the existing 150-MVA transformer at Ariana Substation. Two of these options are: adding auxiliary cooling equipment to the existing transformer and adding a second transformer at the substation. Analyses performed to evaluate these options are included in the report along with associated construction cost estimates.

A third option involves no physical changes to the existing substation or transformer. It involves negotiating with Tampa Electric Cooperative to allow the intermittent, short term overloading of the existing transformer, thus incurring a measured loss in the life expectancy of the transformer. Calpine would then reimburse Tampa Electric Company for the loss of life of the transformer at a pre-determined rate. The actual cost of this option could not be determined at this time, and would depend on the amount of transformer loss of life and the negotiated rate of reimbursement agreed to between Calpine and Tampa Electric Company. However, assuming a reasonable rate can be agreed upon, the overall cost for this option should be much less than either of the other two options.

We hope this report and accompanying documents provide you with the information you needed. If you have any questions regarding the report or any other related issue, please call me.

Sincerely,

A handwritten signature in cursive script that reads 'Frank Alonso'.

Frank Alonso, P.E.

**ANALYSIS OF TRANSMISSION SYSTEM
IMPROVEMENTS IN SUPPORT OF OSPREY ENERGY
CENTER**

APRIL 18, 2000

Prepared For

CALPINE EASTERN CORPORATION

Prepared By



TABLE OF CONTENTS

ANALYSIS OF TRANSMISSION SYSTEM IMPROVEMENTS IN SUPPORT OF OSPREY ENERGY CENTER APRIL 18, 2000

<u>Section</u>	<u>Page</u>
1 Introduction.....	1-1
2 Background.....	2-1
Problem Definition	2-1
Site Inspection and Data Gathering	2-2
3 Analysis.....	3-1
Transmission Line Options	3-1
Transmission Line Design Criteria.....	3-1
Transmission Line Options for Increasing Conductor Size.....	3-3
Substation Transformer Options	3-8
Existing Transformer Ratings	3-8
Transformer Technical Feasibility Analysis.....	3-9
4 Cost Estimates	4-1
5 Conclusions and Recommendations.....	5-1
<u>Appendices</u>	
Appendix A - Calculations	A-1
Appendix B - Pictures.....	B-1
Appendix C - Drawings	C-1

SECTION I

1
2
3
4
5
6
7
8
9
10
11
12
13
14
15
16
17
18
19
20
21
22
23
24
25
26
27
28
29
30
31
32
33
34
35
36
37
38
39
40
41
42
43
44
45
46
47
48
49
50
51
52
53
54
55
56
57
58
59
60
61
62
63
64
65
66
67
68
69
70
71
72
73
74
75
76
77
78
79
80
81
82
83
84
85
86
87
88
89
90
91
92
93
94
95
96
97
98
99
100

SECTION 1

INTRODUCTION

In support of the proposed Osprey Energy Center, Calpine Eastern Corporation (Calpine), the project's developer, contracted Navigant Consulting, Inc. (NCI) to perform a load flow analysis to determine the capacity of the surrounding transmission system to effectively transform and transmit the center's generated electric power to its customers via the Florida transmission grid. The results of that analysis initially indicated that under certain conditions, four existing facilities would restrict the flow of power out from the energy center. The four critical facilities identified in the analysis are owned by Tampa Electric Company (TECO) and are described as follows:

- The Recker to Lake Agnes 230-kV Transmission Line
- The Recker to Crews Lake 230-kV Transmission Line
- The Crews Lake to Pebbledale 230-kV Transmission Line
- The 150-MVA, 225Y/130 - 69Y/38.8 kV transformer at Ariana Substation.

These lines and substation transformer are located in Polk County, Florida near the City of Auburndale, Florida. A schematic diagram of these lines is shown in Drawing No. 1 in Appendix C.

The analysis conducted by NCI indicates that under maximum loading conditions and single contingency failure of related facilities, the transmission lines interconnecting the energy center with the Florida transmission grid should be rated a minimum of 478-MVA. According to TECO, the overall load carrying capacity of the critical transmission lines is to 398-MVA.

The NCI analysis also indicates that under maximum loading conditions and single contingency failure of associated facilities, the transformer at TECO's Ariana Substation will be overloaded to 220-MVA or 47% above its nominal rating of 150-MVA.

Under certain equipment failure scenarios and maximum loading conditions, the existing transmission system does not have the capacity to accommodate the proposed Osprey Energy Center.

In view of the impact the transmission lines and substation transformer could have on the ability of Calpine to operate the generation units at the Osprey Energy Center at full capacity, Calpine has contracted with NCI to perform this analysis of potential transmission system modifications to increase the capacities of these critical facilities.

The scope of this analysis includes a feasibility study to determine how these facilities could be modified, improved, or replaced so that they are able to carry the additional anticipated loads. Cost estimates are provided for recommended modifications and improvements.

SECTION 2

PROBLEM DEFINITION

Most of the Recker to Lake Agnes 230-kV Transmission Line uses tubular steel pole construction with 1590-kcmil, ACSR conductor. However, according to the original information provided by TECO, there was a short line section of old wood pole, H-frame construction with 954-kcmil, ACSR conductors. That section of line was responsible for limiting the overall load carrying capacity of the line to 398-MVA. The rest of the line is rated for 550-MVA. According to more recent information received from TECO, these old sections of the line have been upgraded so that the entire line is now rated 550-MVA.

The Recker to Crews Lake 230-kV Transmission Line is approximately 17 miles long. A major portion of the line uses H-frame structures and 1590-kcmil, ACSR conductor, which provides a load carrying capacity of 550-MVA. However, two short sections of the line, totaling 1.4 miles, located immediately north of Crews Lake Substation, use 954-kcmil, ACSR conductors on wood, H-frame structures. These two short line sections limit the overall capacity of the line to 398-MVA. The capacity of these two line sections needs to be upgraded to match the rest of the line.

The Crews Lake to Pebbledale 230-kV Transmission Line is approximately 6.3 miles long. The entire line uses 954-kcmil, ACSR conductor which limits its load carrying capacity to 398-MVA. The first line section out of Crews Lake Substation is approximately 2.2 miles long and uses wood, H-frame structures. The middle section is approximately 3.1 miles long and uses tubular steel poles with long spans; some exceeding 1000'. The last section of the line is approximately one mile long and uses single pole wood structures. The entire line must be upgraded to 1590-kcmil, ACSR conductor to provide the additional capacity required for the new energy center.

The 230/69-kV auto-transformer at Ariana Substation has a nominal, liquid-immersed, self-cooled (OA) rating of 150-MVA and a liquid-immersed, forced liquid-cooling, forced air-cooled (FOA) rating of 168-MVA (12% over OA rating) with a 55°C/65°C temperature rise. Because of the additional generation at the Osprey Energy Center, under certain load flow conditions, this transformer will be overloaded by almost 50% to 220-MVA. Although this overload condition is not projected to be long lasting, TECO has indicated that they are not willing to operate their transformer above the FOA rating of 168-MVA. Given that constraint, additional transformer capacity will be required at Ariana Substation.

SITE INSPECTION AND DATA GATHERING

On March 22, 2000, representatives from TECO and NCI met at TECO's Recker Substation. The TECO representatives provided line design information and criteria for the two lines under consideration. In addition, they provided nameplate information for the transformer at Ariana Substation. A cursory inspection of the transmission lines near Recker and Ariana Substation was conducted. A visit to Ariana Substation provided a close-up inspection of the 150-MVA transformer.

Photographs taken during the site inspection are included in Appendix B.

SECTION 3

TRANSMISSION LINE OPTIONS

There are only two possible options for increasing the capacity of a power transmission line: increase the line operating voltage or increasing the current carrying capacity of the line by installing a larger conductor or bundling two or more conductors per phase.

For existing lines that are already interconnected within an existing transmission grid, the option to increase the line operating voltage is not cost effective. It involves:

- Voltage transformations at both ends of the line – from the transmission grid voltage to the new line voltage at one end and back from the line voltage to the grid voltage at the other end (The large transformers required makes this option very costly.),
- Replacement of all line structures to accommodate the increased line to ground clearances, conductor to structure clearances, and structure strength requirements, and
- Acquisition of additional right-of-way for operating the line at a higher voltage.

Therefore, in this situation, this option is not cost effective.

Upgrading the transmission line's capacity by increasing the size of the line conductors can sometimes be accomplished with minimal costs. Such would be the case if only the conductors are replaced and all the other hardware and equipment are reused with minor structure adjustments for ground clearances and for the increased loading resulting from the larger conductors. However, typically, the structures are old or not originally designed to handle the increased loading resulting from the larger conductors. Also, in some cases the insulators have to be changed to higher strength type insulators. In most cases, the conductor and shield wire attachment points on the structures will have to be raised to accommodate the greater sag associated with the larger conductors.

TRANSMISSION LINE DESIGN CRITERIA

The Recker to Crews Lake and the Crews Lake to Pebbledale 230-kV Transmission Lines were designed and constructed in the 1960's and use old wood, H-frame structures with suspension insulators or single pole wood structures with post insulators to support the 954 or 1590-kcmil, ACSR conductors. A 3.1-mile section of the Crews Lake to Pebbledale Line uses tubular steel poles with 954-kcmil, ACSR conductor.

The original design met the requirements of the then applicable edition of the National Electrical Safety Code. Any future modifications or improvements to the lines will have to comply with the requirements in the current edition of the same code. Drawing No. 2 in

Appendix C shows TECO's original wood, H-frame structure design used for the major portions of these lines.

A summary of the original design criteria used for the existing H-frame, wood pole line is presented in Table 1 along with TECO's current line design criteria applicable to future lines.

Table 1

	<u>Design Criteria for Existing Lines</u>	<u>Design Criteria for New Lines</u>
CONDUCTOR	954-kcmil, ACSR-S, Code Name "Cardinal"	1590-kcmil, ACSR, Code Name "Lapwing"
OHW	3/8" HS steel	3/8" HS steel
INSULATION	For wood, H-frame: 11 units 5-3/4" X 10" suspension type For single wood poles: 230-kV post insulators For tubular steel poles: polymer insulators in braced post arrangement	If exiting H-frames reused, 11 units 5-3/4" X 10" high strength suspension type If structures are changed to concrete or tubular steel poles, use polymer insulators in a braced post arrangement
LOADING CONDITIONS	Not known.	NESC Light with following limiting conditions: 75°F with 45psf wind (TECO Extreme) 212°F with no-wind (Maximum Sag) 30°F with no-wind (Minimum Sag)
CONDUCTOR SPACING	For H-frame construction: 17' - 6" with 36' crossarm 19' - 6" with 40' crossarm For single pole construction: 10' between phase conductors 12' between top phase conductor and OHGW.	For H-frame construction: 17' - 6" with 36' crossarm 19' - 6" with 40' crossarm For concrete or steel pole construction: 10' between phase conductors 12' between top phase conductor and OHGW.
BASIC POLE HEIGHT	70' - 75' for H-frames 80' - 85' for single poles	70' - 75' for H-frames 80' - 85' for single poles
CLEARANCE TO GROUND	25'	25'

Both sets of design criteria were used in this analysis to evaluate the feasibility of the various options considered for upgrading the transmission lines to 550-MVA capacity. The design criteria for existing lines were used to determine the design loading of the existing transmission lines. The design criteria for new lines were used to determine if the existing lines can support the larger sized conductor and to determine the required strength of new concrete or steel poles to be used if lines had to be rebuilt.

TRANSMISSION LINE OPTIONS FOR INCREASING CONDUCTOR SIZE

Increasing the size of the phase conductors on the existing transmission lines can be accomplished by re-framing the existing wood, H-frame structures or by replacing them with concrete or tubular steel poles. In either case, we assumed the spans lengths and structure alignments remain the same. If the existing structures are reused, obviously, they will be re-framed in place. If new concrete or steel structures are used, they will be installed in close proximity to the existing structures and along the same centerline. With this approach, no additional right-of-way will be required.

Three options were considered in this analysis for increasing the line conductor size to 1590-kcmil. The three options are described as follows:

- Option L1:* Reuse the existing wood, H-frame or single pole, wood structures. Modify structures as required and install new 1590-kcmil conductor.
- Option L2:* Rebuild line in place using spun concrete poles. Install new 1590-kcmil, ACSR conductors on new concrete poles. Then, remove existing wood H-frame structures with 954-kcmil ACSR conductors.
- Option L3:* Rebuild line in place using tubular steel poles. Install new 1590-kcmil, ACSR conductors on new steel poles. Then, remove existing wood H-frame structures with 954-kcmil ACSR conductors.

TRANSMISSION LINE TECHNICAL FEASIBILITY ANALYSIS

Table 2 lists the basic line criteria, conductor data, conductor loads, preliminary structure loading criteria and capacity factors, and resultant vertical and horizontal loads for H-frame, spun concrete, and tubular steel structures proposed for the three options being considered. Overload factors and safety factors are in accordance with applicable sections of the National Electrical Safety Code (NESC).

Table 2

Basic Line Criteria

Max. Wind (psf)	45	(Extreme wind condition on cylindrical surfaces per TECO)
Average Span (ft.)	457	
Max Wind Span (ft.)	571	
Max Weight Span (ft.)	686	
Conductor Loading Const.	0.05	(in lbs./LF from NESC Table 251-1)
Cylindrical Shape Factor	1.0	(Per NESC 252.B.2.a)

Conductor Data

Conductor Type	954 ACSR	1590 ACSR	3/8" HS Steel	7#10 AW
Weight (lbs./LF)	1.229	1.792	0.237	0.1647
Diameter (in.)	1.196	1.504	0.12	0.306

Conductor Loading per NESC 251

Conductor Type	954 ACSR	1590 ACSR	3/8" HS Steel	7#10 AW
Vertical Load (lbs.)	842	1228	187	113
Horizontal Loads (lbs.)	2562	3222	257	656
Resultant Load (lbs.)	2697	3448	318	665
Total Load (lbs.)	2720	3471	341	688

(Total loads include NESC Loading Constant.)

Structure Loading Criteria and Capacity Factors per NESC 252

(Assumed H-frame structures use Class 1 type wood poles.)

	H-Frame W/954	H-Frame w/1590	Concrete Pole	Tubular Steel Pole
Overload Capacity Factors				
Vertical Loads	2.20	2.20	1.50	1.50
Transverse Loads	4.00	4.00	2.50	2.50
Longitudinal Loads	1.33	1.33	1.10	1.10
Average Pole Height (ft.)	70	70	85	85
Setting Depth (ft.)	10.0	10.0	10.5	10.5
Pole Length Exposed to Wind Load (ft.)	60.0	60.0	74.5	74.5
Pole Top Diameter (in.)	8.6	8.6	18.0	13.0
Pole Diameter at Ground Line (in.)	15.76	15.76	32.9	27.9
Pole Wind Load Area (sq. ft.)	63.1	63.1	158.0	127.0

Table 2
(Continued)

Resultant Vertical and Horizontal Loads

	H-Frame W/954	H-Frame w/1590	Concrete Pole	Tubular Steel Pole
Conductor Vertical Load/Phase (lbs.)	1869	2720	1855	1855
OHWG Vertical Load/Wire (lbs.)	257	441	301	301
Weight of Insulators/Phase (lbs.)	363	165	113	113
Conductor Wind Load/Phase (lbs.)	10335	12973	8108	8108
OHWG Wind Load/Wire (lbs.)	2712	1102	689	689
Wind Load on Poles (lbs.)	2839	2839	7110	5713

TECHNICAL FEASIBILITY OF OPTION L1

The main consideration when increasing the size of line conductors is to determine if the existing structures can support the increased loading resulting from the higher weight and wind loading associated with the larger conductors.

Inherently, wood, H-frame structures are relatively strong and provide greater flexibility than single pole steel or concrete structures. However, they are statically indeterminate structures and difficult to analyze. There are various techniques available for analyzing H-frame structures: (1) classical indeterminate structural analysis, (2) matrix method of structural analysis, and (3) approximate method. The approximate method will be used for this feasibility analysis for the following reasons:

- Wood is a variable product. More accurate analysis techniques do not always mean assured safety,
- Classical indeterminate analysis and matrix methods are too cumbersome,
- Loading inputs for the classical indeterminate analysis and matrix methods cannot be predicted or determined with a high degree of accuracy.

The approximate method was used to analyze the strength of the existing H-frame structures to determine if they can withstand the additional loading resulting from the use of 1590-kcmil ACSR phase conductors. The calculations, included in Appendix A, show the maximum span limitations resulting from comparing the resultant moment from wind loading on poles and conductors at selected critical points along the length of the poles with the available moment capacity of the poles at that same point. The results of the calculations show the following:

- The resultant moment at the point of crossarm attachment allows a maximum span of 352 ft. This is much less than the existing average span of 457 ft.
- The resultant moment at the top cross brace attachment point allows a maximum span of 448 ft. Again, this is less than the existing average span.
- The resultant moment at the bottom cross brace attachment point allows a maximum span of 105 ft. It is also well below the existing average span.
- The resultant ground line moment allows for a maximum span of 203 ft.

Single pole wood structures are easier to analyze than H-frame structures. The typical structure strength calculations are included in Appendix A. They show that the maximum span resulting from comparing the resultant moment from wind loading on the pole and conductors with the ultimate ground line moment of the pole is 14.49 feet which is much less than the existing average span of 275.4 feet.

Clearly, from the results of the H-frame and single pole maximum allowable spans calculations, the existing H-frame and single wood pole structures cannot support the 1590-kcmil, ACSR conductors without major modifications that would be more costly than total line replacement. For this reason, this option was eliminated from further consideration.

TECHNICAL FEASIBILITY OF OPTIONS L2 AND L3

The technical analysis of these two options can be combined because they are very similar in construction and appearance. The loading analysis for these structures is very similar. Currently TECO uses both spun cast concrete poles and tubular steel poles for 230-kV transmission lines throughout their system. The technical feasibility of using either of these types of structures for upgrading the lines has been proven by other existing TECO lines that use 1590-kcmil, ACSR conductors. (See Pictures 12 through 14, 18 through 21, and 24 in Appendix B.)

Generally, tubular steel poles are stronger than wood or concrete poles. They are typically used in situations where guying is required, but not possible, or where longer spans are desired or required. Self supported angle and corner structures are typically made from tubular steel. Tubular steel poles are fabricated and shipped in sections that are assembled at the job site. Thus, they require smaller cranes and erection equipment during construction. Because they are fabricated in sections, they are also better suited for lines built along right-of-ways with difficult or limited access. The smaller pole sections are easier to maneuver through difficult turns and restricted areas.

The major disadvantages of tubular steel poles are higher initial cost, corrosion, the need for foundations and anchor bolts, and they are difficult to modify in the field.

Although steel galvanizing processes have improved, the section joints and other bolted connections on tubular steel poles are prone to corrosion problems. These can be minimized by careful installation procedures that minimize the damaged to the galvanizing coating. Because they are susceptible to corrosion, most utilities avoid direct burial of tubular steel poles. Typically, they are provided with a concrete foundation that requires precise placement, spacing, and embedment of anchor bolts. The foundations and anchor bolts also increase overall line construction costs.

Modification of tubular steel pole structures in the field is very difficult because they cannot be field drilled. They are shipped from the factory complete with welded flanges and other provisions for the installation of insulators and other hardware. Any field modifications are usually accomplished with steel bands around the pole or by having factory personnel come out to the field to make the required modifications. Any field changes that involve removing and replacing the galvanizing coat on the steel becomes a potential source for corrosion.

The initial cost of tubular steel poles can be 30 to 50% higher than concrete poles. However, because they are stronger, the average span of the line can be increased thereby reducing the total number of poles required and bringing the overall constructed cost of the line down to the same range as with concrete poles. Since we will not be changing the existing span lengths for the existing transmission lines, the ability to go longer spans is not applicable negating the strength advantage tubular steel poles have over concrete poles.

Spun cast concrete poles are heavier than but not as strong or as expensive as tubular steel poles. They provide sufficient strength for average transmission line spans of 400 to 600 feet, depending on the size of the conductors, maximum wind loading conditions, and soil conditions. Concrete poles can be directly buried requiring no foundation or anchor bolts. Where soil conditions require it, they are provided with a concrete footing to spread the bearing load at the bottom of the pole and with concrete backfill to provide greater distribution of side bearing loads on the sides of the hole.

With certain limitations, spun concrete poles can be field drilled by construction crews making it possible to make framing modifications during construction.

For upgrading the existing transmission lines, we recommend the use of spun concrete poles. They are currently used by TECO on other transmission lines and they provide the strength and versatility required for such a project. Most of the structures will have a tangent conductor alignment. Where guying is required, the existing right-of-way is wide enough to allow it. In fact, the existing structures are guyed at angle locations.

The cost estimate for increasing the electrical load carrying capacity of the existing transmission lines from Recker to Crews Lake and from Crews Lake to Pebbledale were prepared based on the use of spun cast concrete poles.

SUBSTATION TRANSFORMER OPTIONS

There are two options for increasing the capacity of the transformer at Ariana Substation. They are described as follows:

Option T1: Increase the capacity of the existing transformer by adding auxiliary cooling equipment, or

Option T2: Adding a second transformer at the substation.

EXISTING TRANSFORMER RATINGS

The nameplate information for the existing transformer was provided by TECO and is summarized in the following Table 3.

Table 3

Manufacturer:	McGraw-Edison Power Systems Division
Serial Number:	C04020-5-1
Class:	FOA
Number of Phases:	3
Frequency:	60-Hz
KVA Rating:	150000/168000 kVA
Voltage Ratings:	225000GRD.Y/129904-69000GRD.Y/39837 Volts
Temperature Rise:	55°/65°C Rise @ Full Load Continuously
Percent Impedance:	8.6% at 150000-kVA
Basic Lightning Impulse Insulation Level:	825-kV high voltage side 350-kV low voltage side 150-kV neutral bushings
Approximate Total Mass:	318,400 Lbs.
Insulating Liquid:	Mineral Oil

TRANSFORMER TECHNICAL FEASIBILITY ANALYSIS

The autotransformer at Ariana Substation has a nominal, OA rating of 150-MVA. To reach its FOA rating of 168-MVA, it has two sets of radiators, oil pumps, and fans mounted on the north side of the transformer as shown in Pictures 2, 3, 6 and 7 in Appendix B. It is not clear, if the FOA rating is achieved in stages or if the cooling fans and pumps all come on at the same time. They seem to be separate, independent systems.

The substation layout provides space for the future addition of a second transformer next to the existing one.

The American National Standards Institute (ANSI) Standard C57.92, IEEE Guide for Loading Mineral-Oil-Immersed Power Transformers Up to and Including 100-MVA with 55 °C or 65 °C Average Winding Rise, provides transformer loading limits for normal operation and for moderate sacrifice of life. Although intended for transformers rated less than 100-MVA the Standard can be applicable to this transformer with certain restrictions. The standard says:

“Loading of transformers larger than 100-MVA may be limited by factors other than insulation aging such as stray flux, etc. When it is known that such limitations do not exist and insulation aging rather than oil temperature, gassing, tank heating, etc is the controlling factor, this guide may be used.”

Assuming the loading of the transformer at Ariana Substation is not restricted by any of the limiting factors referred to in ANSI Standard C57.92 and that the original transformer design was performed in accordance with ANSI Standard C57.12.00, then its loading limitations can be determined using the information provided in ANSI Standard C57.92.

According to Table 5(1) of ANSI C57.92, with ambient temperature of 30 °C (86 °F), the Ariana transformer can be continuously loaded to 100% of its FOA rating. Under those loading conditions, according to the ANSI Standard, the transformer will reach its normal life expectancy of 6.5×10^4 hours (7.4 years) which represents a normal daily loss of life of 0.0369%. The actual life expectancy of the transformer should be considerably greater than 6.5×10^4 hours since it is not fully loaded 100% of the time and ambient temperature is not always 30°C. For most transformers, actual life expectancy is 30 to 35 years.

To stay within the temperature rise limitations of the transformer, the continuous load has to be reduced whenever the ambient temperature increases above 30 °C. For example, at 40 °C (104 °F), the continuous load has to be reduced to 91% of the FOA rating or 153-MVA so as not to shorten the life expectancy of the transformer.

At the 30°C ambient temperature, the transformer can be loaded as follows:

Duration	Peak Load (MVA)	Percent of FOA Rating	Percent Loss of Life
½ Hour	274	163	0.25
1 Hour	250	149	0.25
2 Hours	232	138	0.25
4 Hours	217	129	0.25
8 Hours	207	123	0.25
24 Hours	193	1.15	0.25

The table shows that for a 0.25% reduction in the normal life expectancy of the transformer it can be loaded for over 4 hours at 220-MVA which is the overload condition projected by the NCI study for the transformer at Ariana.

This points to an option that cannot be quantified at this time, but one we recommend pursuing with TECO. According to the NCI study, the transformer overload condition is expected to last less than one-hour. Since it will be of such short duration, the anticipated loss of life will be less than 0.25%. We have extrapolated the data provided in Table 5 (l) in ANSI Standard C57.92 and determined that the projected loss of life for operating the transformer at 220-MVA for one-hour each day would be 0.16%. That equates to a reduction of 4.3 days from the normal life expectancy of the transformer for each occurrence of this overload condition.

It should be possible, and probably less costly to negotiate a price with TECO for this projected loss of life so that they would be made whole in case such an overload condition occurred. This would eliminate the need to pursue the options being considered.

TECHNICAL FEASIBILITY OF OPTION T1

Before considering the detailed technical feasibility of this option, the construction sequence for its implementation should be reviewed. Replacing the radiator, cooling fans and oil circulating pumps on the existing transformer will require its removal from service for a long time. Since this is the only transformer at Ariana Substation, removing it from service essentially shuts down the entire substation and removes one source feeding TECO's 69-kV system. Therefore, to perform the required transformer modifications, the installation of a temporary transformer may be required to maintain the substation operational while the transformer is being modified.

This requirement will be included in the cost assessment of this option.

To increase the forced cooled loading capacity of the existing transformer to 220-MVA (50% above its OA rating), additional auxiliary cooling equipment such as fans, external forced-oil coolers, or water spray equipment will have to be provided. The amount of additional loading capacity resulting from the addition of auxiliary cooling equipment varies widely, depending upon:

- Design characteristics of the transformer
- Type of auxiliary cooling equipment provided

No general rules can be given for such supplemental cooling. Each transformer must be evaluated individually.

The standard levels of overload capacity using auxiliary cooling equipment are 125%, 133%, and 166% of the transformer's OA rating, corresponding to 187.5, 199.5, and 249-MVA respectively for the Ariana Substation transformer. These levels are industry wide standards. Therefore, an increase to 220-MVA rating for the Ariana transformer is within standard industry practice.

However, unless provisions were made in the original transformer design for the future addition of cooling equipment, retrofitting such equipment on an existing transformer can be expensive and limited by the original design criteria. And, the effectiveness of such modifications is not always predictable.

Internal limitations may also exist that are difficult to evaluate without additional information about the detailed design of the transformer. Some of these are:

- Capacity for oil expansion
- Size of internal leads
- Tap Changer current carrying capacity
- Stray flux heating.

In addition, there are external limitations that must also be considered such as the thermal capability of associated equipment such as busses, conductors, cables, circuit breakers, disconnecting switches, and current transformers.

At 69-kV, the original design provided for a minimum of 1400-A per phase at the FOA loading level. At the projected load of 220-MVA, the phase current would be 1840-A. That represents an additional 440-A per phase on the 69-kV side of the transformer. All external 230-kV and 69-kV equipment associated with the transformer should be capable of carrying the additional current.

Assuming there are no internal or external limitations to increasing the rating of the transformer to 220-MVA, adding cooling fans to the existing transformer would require major modifications. The existing radiators would have to be replaced with much larger units with greater surface area to make the fans more efficient. Additional radiators would be required. They could be installed on the west side of the transformer, which is the only unencumbered side. The potential transformers and air-break switches north of the transformer will have to be relocated along with their associated support structures and foundations. (See Pictures 6, 7, 10, 11, 16, and 17 in Appendix B.)

The existing fans and oil circulating pumps are fed from an auxiliary transformer rated 75-kVA. It will not have sufficient capacity to provide a viable source of power for the larger number of fans and oil circulating pumps required. The associated power distribution panelboard will also have to be replaced to provide a greater number of circuits for the new fans and pumps.

Pumping the oil through the radiators would reduce the number of fans required. However, the efficiency of forced oil circulation is limited by diminishing returns. In order to release the optimum amount of heat the oil has to be in contact with the cooled radiator surfaces for a given period of time. The length of contact time required is determined by the ambient temperature and humidity, the heat exchange ratios between the oil and the radiators, and the amount of heat the external fans can remove from the radiators.

Forcing the flow of oil through the radiators faster than the required amount of time it takes for optimum heat removal is not cost effective. Typically, oil-pumping equipment can provide between a 12% and 20% increase in the rating of the transformer. That would provide a boost of 18 to 30-MVA. The remaining 40 to 52-MVA required over the OA rating will have to be provided by cooling fans.

In conclusion, while the addition of auxiliary cooling equipment to increase the rating of the existing transformer at Ariana Substation is technically feasible, it will require extensive modifications to the transformer and the surrounding equipment. It will also require the installation of a temporary transformer to maintain the substation in service during construction.

The proposed modifications will include the following as minimum:

- Coordinating with TECO and transformer manufacturer to verify that the rating increase is not limited by the internal transformer limitations discussed previously,
- Verifying that the ratings and capacities of associated equipment and hardware are high enough to accept the increased currents and associated heating,
- Installing a temporary transformer with associated busses, disconnect switches, and with self contained metering and relaying devices,
- If required, replacing external equipment that is undersized for the increased current flows,
- Relocating existing air-break switches and potential transformers with associated supports,
- Removing existing radiators with associated fans, oil circulating pumps, and associated piping and replacing with larger radiators with new fans, oil circulating pumps, and piping, and
- Relocating existing lightning arrestors currently located directly over the existing radiators.

TECHNICAL FEASIBILITY OF OPTION T2

The approach for adding a second transformer at the Ariana Substation includes providing a new transformer bay adjacent to the existing transformer. The substation layout provides space for a second transformer to be added at a future date. There are no technical limitations for the implementation of this option.

SECTION 4

SECTION 4

COST ESTIMATES

Prices for equipment, materials, and labor were obtained from past NCI projects, local contractors, vendors, manufacturers, and other utilities. All prices were adjusted to 1999 prices using the "handy-Whitman Index of Public Utility Construction Costs". The 1999 prices were increased by 3% to approximate Y2000 prices. This increase is based on an assumed annual inflation rate of 3%.

Table 4 provides a breakdown of the estimated construction cost for upgrading the two short sections of the Recker to Crews Lake Line that currently uses 954-kcmil, ACSR conductor. Table 5 provides a breakdown of the estimated cost for upgrading the structures and conductors in the wood pole sections of the Crews Lake to Pebbledale Line and the conductor in the existing section of the line that currently uses single pole tubular steel structures. Table 6 provides a breakdown of the estimated construction costs for adding auxiliary cooling equipment to the existing 150-MVA transformer at Ariana Substation. Finally, Table 7 provides a breakdown of the estimated construction cost for adding a second transformer at Ariana Substation.

The following budget level construction cost estimates have an accuracy of $\pm 15\%$.

Table 4

**Construction Cost Estimate for
Upgrading Sections of the
Recker to Crews Lake 230-kV Transmission Line**

Assumptions: Flat terrain
Normal access
1590-kcmil ACSR conductor
3/8" overhead ground wire
Existing right-of-way is adequate
No environmental statement required
Poles are spun cast concrete
Line is single circuit
Line section length is 7387' (= 1.4 miles)
Number of tangent structures = 14
Number of corner structures = 4
Number of deadend structures = 1

Table 4
(Continued)**Cost Estimate:**

Concrete Poles	104,710
Guying	23,000
Conductor	209,860
Overhead Ground Wire	34,010
Insulators and Hardware	53,120
Demolition	12,470
Surveying	4,200
Geological Investigation	7,000
Engineering	67,260
Construction Services	<u>53,800</u>
TOTAL	\$569,430

Table 5

Construction Cost Estimate for Upgrading the Crews Lake to Pebbledale 230-kV Transmission Line

Assumptions: Flat terrain
 Normal access
 1590-kcmil ACSR conductor
 3/8" overhead ground wire
 Existing right-of-way is adequate
 No environmental statement required
 New poles will be spun cast concrete
 Line is single circuit
 Line length is 33,088' (= 6.3 miles)
 Number of tangent structures = 47
 Number of corner structures = 10
 Number of deadend structures = 2
 Number of angle structures = 6

Cost Estimate:

Concrete Poles	155,340
Guying	50,600
Conductor	710,940
Overhead Ground Wire	110,420
Insulators and Hardware	83,900
Demolition	40,440
Surveying	9,600
Geological Investigation	16,000
Engineering	129,500
Construction Services	<u>117,720</u>
TOTAL	\$1,424,460

Table 6**Construction Cost Estimate for
Adding Auxiliary Cooling Equipment to
Existing Transformer at Ariana Substation**

Assumptions: No site work required
Normal access
Soil is adequate for new equipment foundations
No additional land required
No control building required
No environmental statement required
Existing transformer suitable for upgrading

Cost Estimate:

Auxiliary Cooling Equipment	370,330
Modifications to Existing Transformer	166,650
Installation of Cooling Equipment	53,700
Adjustments and Relocation of Surrounding Equipment	113,130
Temporary Transformer	281,420
Demolition	83,770
Surveying	7,200
Engineering	160,350
Construction Services	<u>128,280</u>
TOTAL	\$1,364,830

Table 7

**Construction Cost Estimate for
Adding a Second Transformer at Ariana Substation**

Assumptions: No site work required
Normal access
Soil is adequate for new foundations
No additional land required
No control building required
No environmental statement required
Existing transformer stays
New transformer is 150-MVA, FOA to match existing

Cost Estimate:

New Transformer	2,574,690
Circuit Protection Device (Breaker)	187,720
Switches	58,740
Control and Protection Systems	83,010
Bus Systems (230-kV and 69-kV)	126,420
Equipment Support Foundations	152,390
Surveying	12,000
Engineering	477,450
Construction Services	<u>381,960</u>
TOTAL	\$4,054,380

SECTION 5

CONCLUSIONS AND RECOMMENDATIONS

The existing wood, H-frame and single pole structures in sections of the Recker to Crews Lake and Crews Lake to Pebbledale 230-kV Transmission Lines are not strong enough to support the larger 1590-kcmil, ACSR conductors. Therefore, those line sections should be upgraded using spun cast concrete poles. Upgrading the line sections in the Recker to Crews Lake Line will cost approximately \$549,880. Upgrading the sections of the Crews Lake to Pebbledale Line will cost approximately \$1,424,460.

To resolve the transformer overloading problem at Ariana Substation we looked at two conventional options and one potential option that requires no physical modifications to the Substation; but does require entering into negotiations with TECO regarding compensation for the planned loss of life of the transformer.

For obvious economic and scheduling reasons, we recommend pursuing the following options in the order in which they are:

- Making no changes at the substation and entering negotiations with TECO to arrive at an equitable method for reimbursing them for the loss of life of the transformer resulting from the short periods of overloading above its FOA rating.
- Adding auxiliary cooling equipment to the existing transformer to increase its capacity by 50% to 220-MVA. While this is technically feasible and less costly than installing a new larger transformer at the Substation, it is subject to many limitations including those limitations imposed by the original transformer design. These limitations are not apparent from a physical inspection of the transformer. Therefore, we were not able to evaluate them. This option requires the installation of a temporary second transformer at the substation to maintain the station in service while the modifications are made to the existing transformer.
- Adding a second transformer at Ariana Substation is the most costly option. While it does not carry any of the caveats that the two previous options have, it is three times more costly than the addition of cooling equipment to the existing transformer. It requires the installation of a new transformer bay at the station with associated breakers, bus, and switches.

①

Calculation of Max Horiz Spans for
H-Frame, Wood Pole Structure

Conductor 13 1590 ACSR

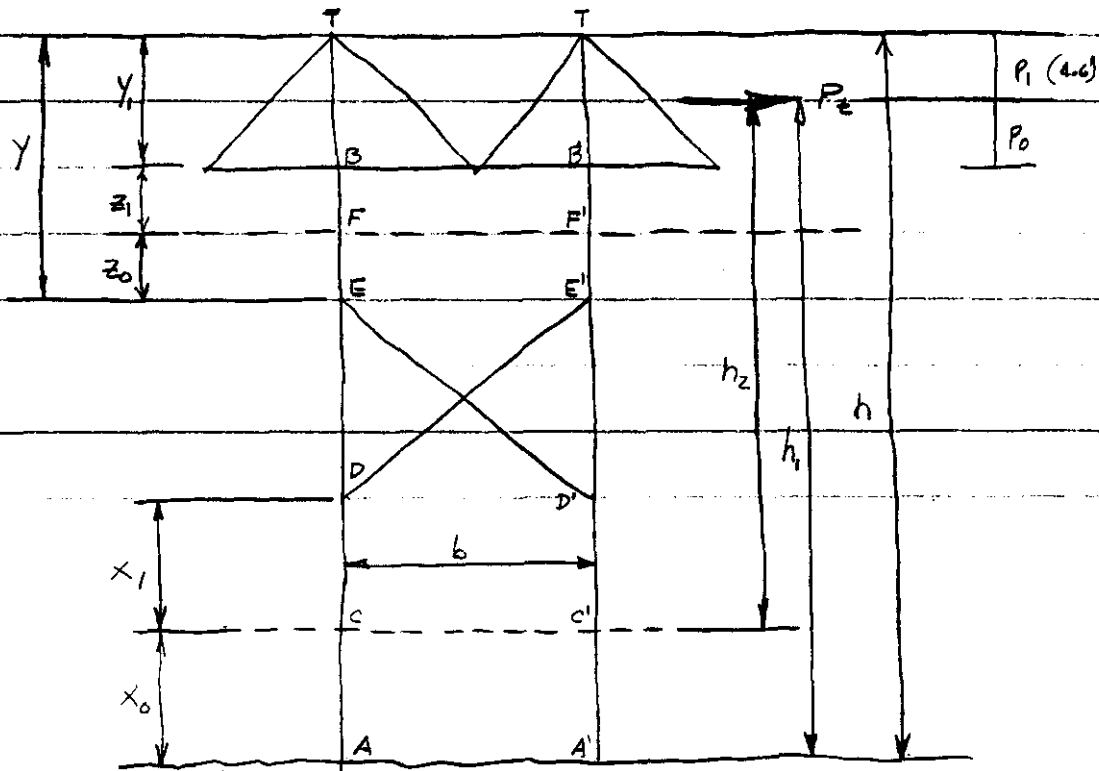

For the TECO Structure:

$Y = 19'$

$x_1 + x_0 = 21'$

$Y_1 = 10'$

$z_1 + z_0 = 9'$

$h = 59'-6"$

$P_1 + P_0 = 10'$

$b = 19'-6"$

$h_1 = 60' - 4.6' = 55.4'$

$$\frac{x_0}{x_1 + x_0} = \frac{C_A(z_1 C_A + C_D)}{2(C_A^2 + C_A C_D + C_D^2)}$$

$h_2 = h_1 - x_0 = 55.4' - 11.3'$

Where: C_A = circumference at point A = 49.5"

$h_2 = 44.1'$

C_D = circumference at point D = 44"

$$X_0 = \left[\frac{49.5 \left[\frac{143}{2} (2 \times 49.5) + 44 \right]}{2 \left[(49.5)^2 + (49.5 \times 44) + (44)^2 \right]} \right] \times 21'$$

$$X_0 = 11.3' \Rightarrow X_1 = 9.7'$$

Also

$$\frac{Z_0}{Z_1 + Z_0} = \frac{C_E (2C_E + C_B)}{2(C_E^2 + C_E C_B + C_B^2)} \quad \text{Where: } C_E = \text{circumference at point E} = 34.5'$$

$$C_B = \text{circumference at point B} = 30.8'$$

$$Z_0 = \left[\frac{3443.1}{2 \left[(34.5)^2 + (34.5 \times 30.8) + (30.8)^2 \right]} \right] \times 9$$

$$Z_0 = 4.8 \Rightarrow Z_1 = 4.2'$$

$$\frac{P_0}{P_1 + P_0} = \frac{C_B (2C_B + C_T)}{2(C_B^2 + C_B C_T + C_T^2)} \quad C_B = \text{circumference at point B} = 30.8''$$

$$C_T = \text{circumference at point T} = 27''$$

$$P_0 = \left[\frac{2728.88}{2 \left[(30.8)^2 + (30.8 \times 27) + (27)^2 \right]} \right] \times 10'$$

$$P_0 = 5.4' \Rightarrow P_1 = 4.6'$$

Max Horizontal Spans (w/ 1590 ACSR Cond. on H-Frames)

$$HS_B = \left[M_B - \frac{(OCF)(F)(Y-z_0)(d_t + d_f)(z_1)}{2} \right] / \left[\frac{(OCF)(P_t)(z_1)}{2} \right]$$

Where: HS_B = Max. Horiz. Span due to moments at point B

23,000 lbs

M_B = Moment capacity at point B (ft-lbs)

OCF = Overload capacity factor

F = Wind pressure on cylindrical surface (psf)

Y = 19'

z_0 = 4.8'

d_t = Pole diameter at pole top (ft)

d_f = Pole diameter at point F (ft)

z_1 = 4.2'

P_t = Total horiz force/LF due to wind on conductors & OHGW (lbs/ft)

In this case: M_B = 61,400 (ft-lbs) from REA Bulletin

1724E-200, Appendix F

Page F-11

OCF = 4.0 from NESC

F = 45 (psf)

d_t = 8.6/12 (ft)

d_f = 10.97/12 (ft)

P_t = (5.64 lbs/ft x 3) + (45 lbs/LF x 2)

= 17.82

So:

$$HS_B = \left[\frac{61,400 - \frac{4.0 \times 45 \times 14.2 \times 1.63 \times 4.2}{2}}{\frac{4.0 \times 17.82 \times 4.2}{2}} \right]$$

$$HS_B = \frac{61,400 - 8749.19}{149.69} = \underline{351.73'} < 457' \text{ Exist. Avg. Spd}$$

$$HS_E = \left[M_E - \frac{(OCF)(F)(Y-z_0)(d_t + d_p)(z_0)}{2} \right] / \left[\frac{(OCF)(P_T)(z_0)}{2} \right]$$

Where: HS_E = Max. Horiz. Span due to moments at point E
 M_E = Moment capacity of point E (ft-lbs)

All other variables are the same

In this case: $M_E = 86,700$ (ft-lbs)

$$HS_E = \left[86,700 - \frac{4.0 \times 45 \times 14.2 \times 1.63 \times 4.8}{2} \right] / \left[\frac{1.0 \times 17.82 \times 4.8}{2} \right]$$

$$HS_E = \frac{86,700 - 9999.01}{171.07} = \underline{448.36'} < 457' \text{ Avg. Span}$$

(5)

$$HS_D = \left[M_D - \frac{(OCF)(F)(h-x_0)(x_1)(d_t+d_c)}{2} \right] / \left[\frac{(OCF)(P_c)(x_1)}{2} \right]$$

Where: HS_D = Max Horiz. Span due to moments at point D

M_D = Moment capacity at point D (ft-lbs)

d_c = Pole diameter at Point C (ft)

In this case: $M_D = 152,200$ (ft-lbs)

$d_c = 14.08/12$ ft

All other variables have the same meanings & values

So:

$$HS_D = \left[152,200 - \frac{4 \times 45 \times 48.2 \times 9.7 \times 1.89}{2} \right] / \left[\frac{4 \times 17.82 \times 9.7}{2} \right]$$

$$HS_D = \frac{152,200 - 79,528.55}{691.42} = \underline{\underline{105.1'}} \ll 457' \text{ Exist Avg Sp}$$

$$HS_A = \left[M_A - \frac{(OCF)(F)(h-x_0)(x_0)(d_t-d_c)}{2} \right] / \left[\frac{(OCF)(P_t)(x_0)}{2} \right]$$

Where: HS_A = Max. Horiz. Span due to moments at point A, ground line moments.

M_A = Moment capacity at point A (ft-lbs)

In this case: $M_A = 256,000$ (ft-lbs)

All other variables have the same meanings & values

So:

$$HS_A = \left[256,000 - \frac{4.0 \times 45 \times 48.2 \times 11.3 \times 1.89}{2} \right] / \left[\frac{4 \times 17.82 \times 11.3}{2} \right]$$

$$HS_A = \frac{256,000 - 92,646.67}{805.46} = \underline{202.8'} < 457'$$

Calculation of Max Horiz Spans for Single Wood Pole Structure

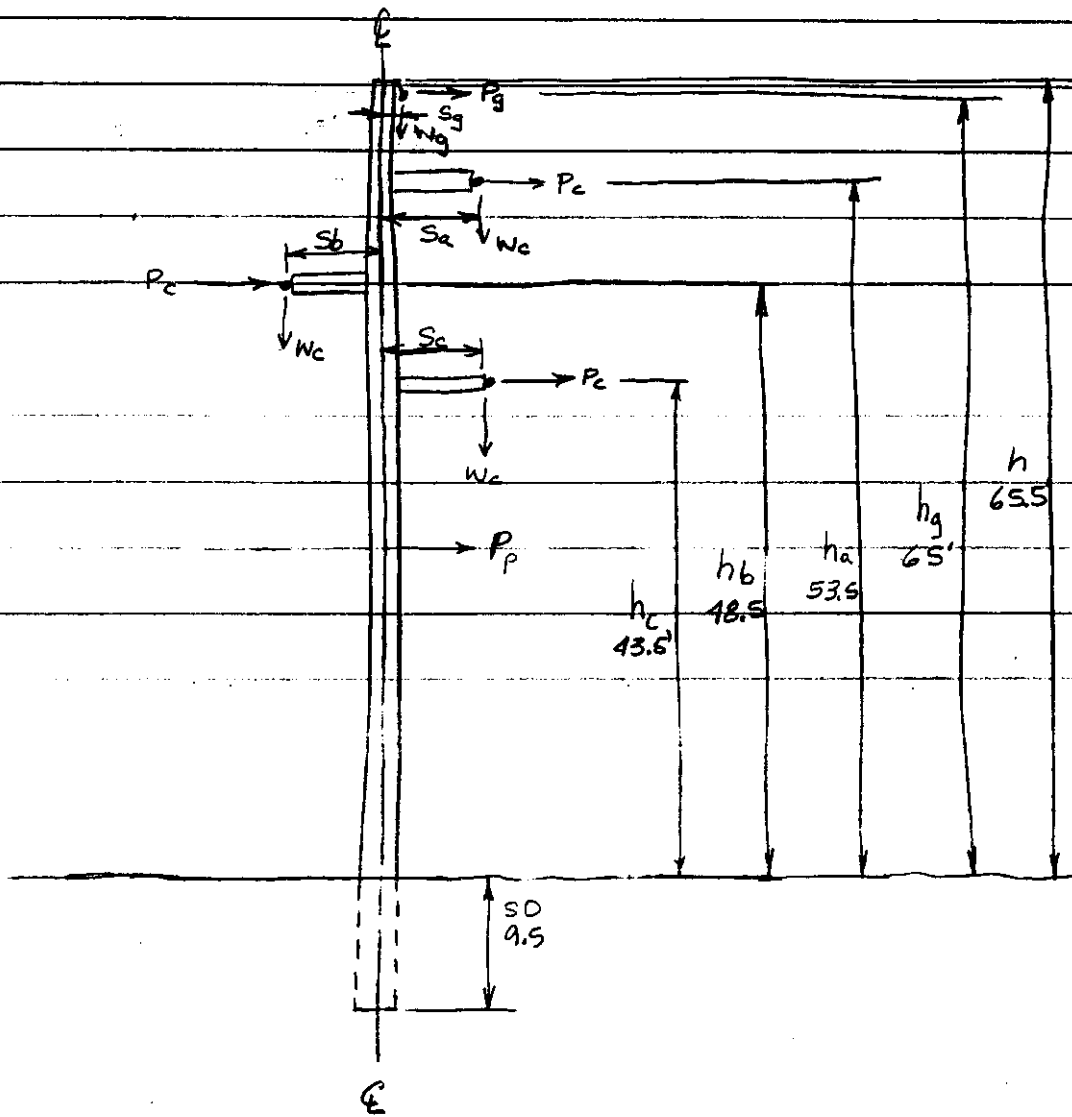

Assume: Pole is 75' tall

Conductors are Δ configuration

Max wind loading 45 psf

Horiz. Span = 280'

Vertical Span = 300'

Ruling Span = 275.4' (calculated)

No adjustment Required for additional sag.

Assume Poles are Class H-1

Max Horiz. Span (w/1590 ACSR Cond.)

$$HS = \frac{M_A (OCF) (M_{wp})}{(OCF) [(P_c)(h_a + h_b + h_c) + (P_g)(h_g)] + (OCF) [(W_c)(s_a + s_b + s_c) + (W_g)(s_g)]}$$

Where: M_A = Ultimate Groundline Moment Capacity of Pole

OCF = Overload Capacity Factor (from NESC)

$M_{wp} = \frac{(P_p)(z d_t + d_a)(h)^2}{6}$ = Moment Due to Wind
on pole (ft-lbs)

Where: P_p = Wind Press. on Pole (psf)

d_t = Pole Top Diameter (ft)

d_a = Pole Groundline Diameter (ft)

h = Pole Height Above Groundline (ft)

HS = Horizontal Span (ft)

P_c = Wind Pressure on Conductor per Unit Length
(lbs/ft)

h_a = Height of A Phase (ft)

h_b = " " B Phase (ft)

h_c = Height of C Phase (ft)

P_g = Wind Press. on OHGW per Unit Length (lbs/ft)

h_g = Height of OHGW (ft)

W_c = Weight of Cond per Unit Length (lbs/ft)

s_a = Horiz. Dist. from Pole Center to A Phase (ft)

s_b = " " " " " " B Phase (ft)

s_c = " " " " " " C Phase (ft)

W_g = Weight of OHGW per Unit Length (lbs/ft)

s_g = Horiz. Dist. from Pole Center to OHGW (ft)

In this case:

$$M_A = 331,700 \text{ ft-lbs (from REA Bulletin 1724E-200, App. F, Pg. F-1)}$$

$$OCF = 4.0 \text{ (from NESC)}$$

$$P_p = 45 \text{ psf}$$

$$d_t = .769 \text{ ft}$$

$$d_a = 1.43 \text{ ft}$$

$$h = 65.5 \text{ ft}$$

$$P_c = 5.64 \text{ lbs/ft}$$

$$h_a = 53.5 \text{ ft}$$

$$h_b = 48.5 \text{ ft}$$

$$h_c = 43.5 \text{ ft}$$

$$P_g = .45 \text{ lbs/ft}$$

$$h_g = 65 \text{ ft}$$

$$W_c = 1.792 \text{ lbs/ft}$$

$$S_a = 5 \text{ ft}$$

$$S_b = 5 \text{ ft}$$

$$S_c = 5 \text{ ft}$$

$$W_g = .273 \text{ lbs/ft}$$

$$S_g = .63 \text{ ft}$$

So:

$$M_{wp} = \frac{45 \times (2 \times .769 + 1.43) (65.5)^2}{6} = \underline{\underline{95,501 \text{ ft-lbs}}}$$

$$HS = \frac{331,700 - (4 \times 95,501)}{4 \left[\frac{5.64 \times (53.5 + 48.5 + 43.5)}{145.5} + \frac{45 \times 65}{29.25} \right] + 4 \left[\frac{1.792(10)}{17.92} + \frac{.273 \times (.63)}{.17199} \right]}$$

$$HS = \frac{331,700 - 382,004}{3399.48 + 72.37} = - \frac{50,304}{3471.85} = - \underline{\underline{14.49'}}$$

Negative No. implies pole is not strong enough to carry 1590 kcmil conductors.

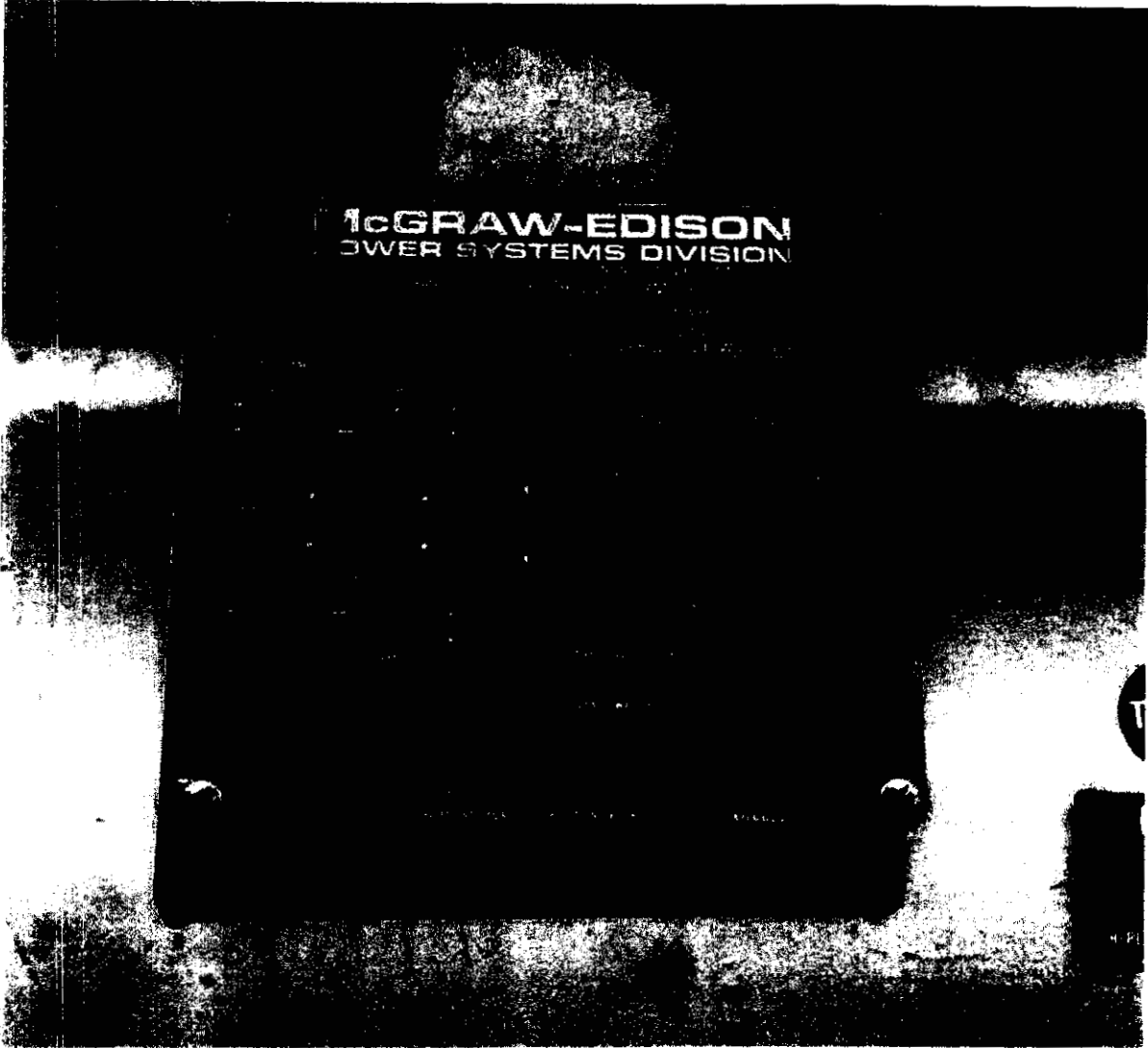

Picture 1: Nameplate for 75-KVA station power transformer mounted on 150-MVA transformer at Ariana Substation.

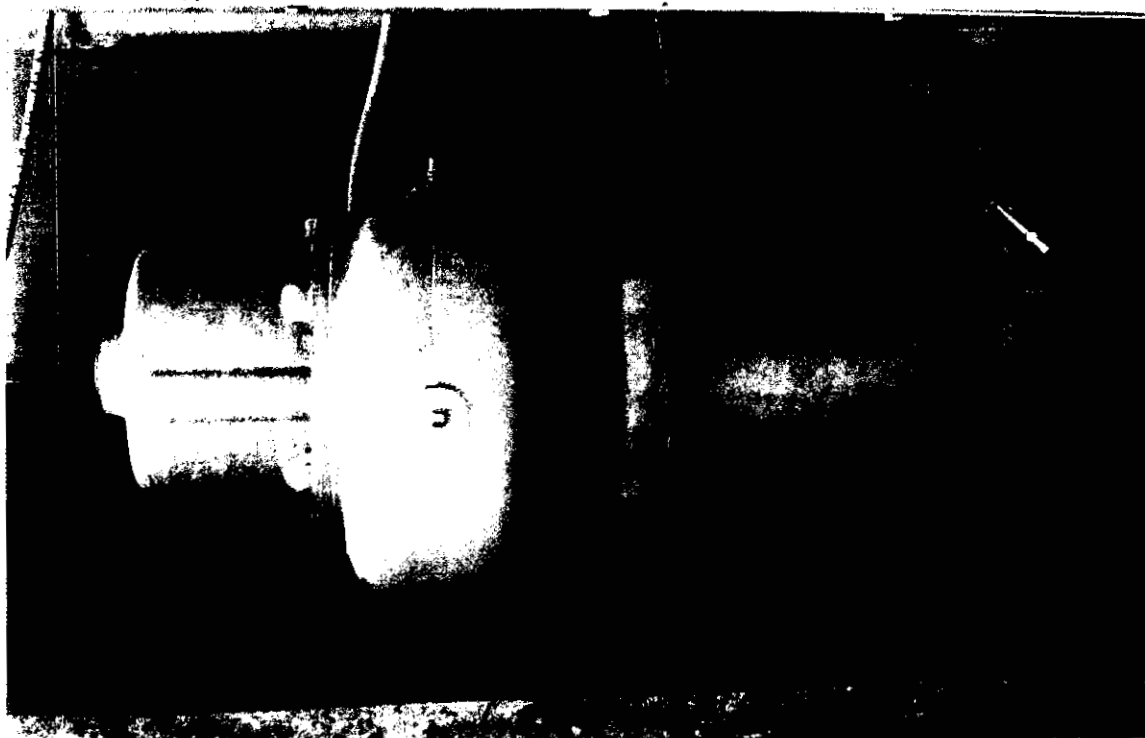

Picture 2: Oil pump for west radiator on 150-MVA transformer

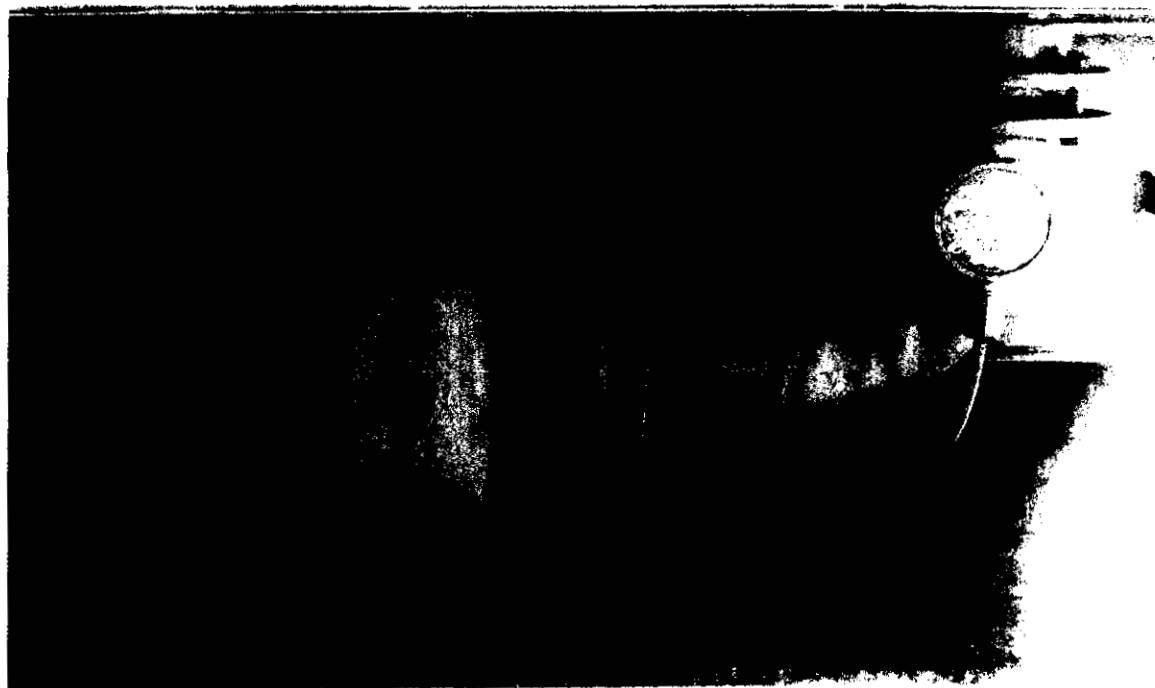

Picture 3: Oil pump for east radiator on 150-MVA transformer



Picture 4: 150-MVA Transformer Nameplate

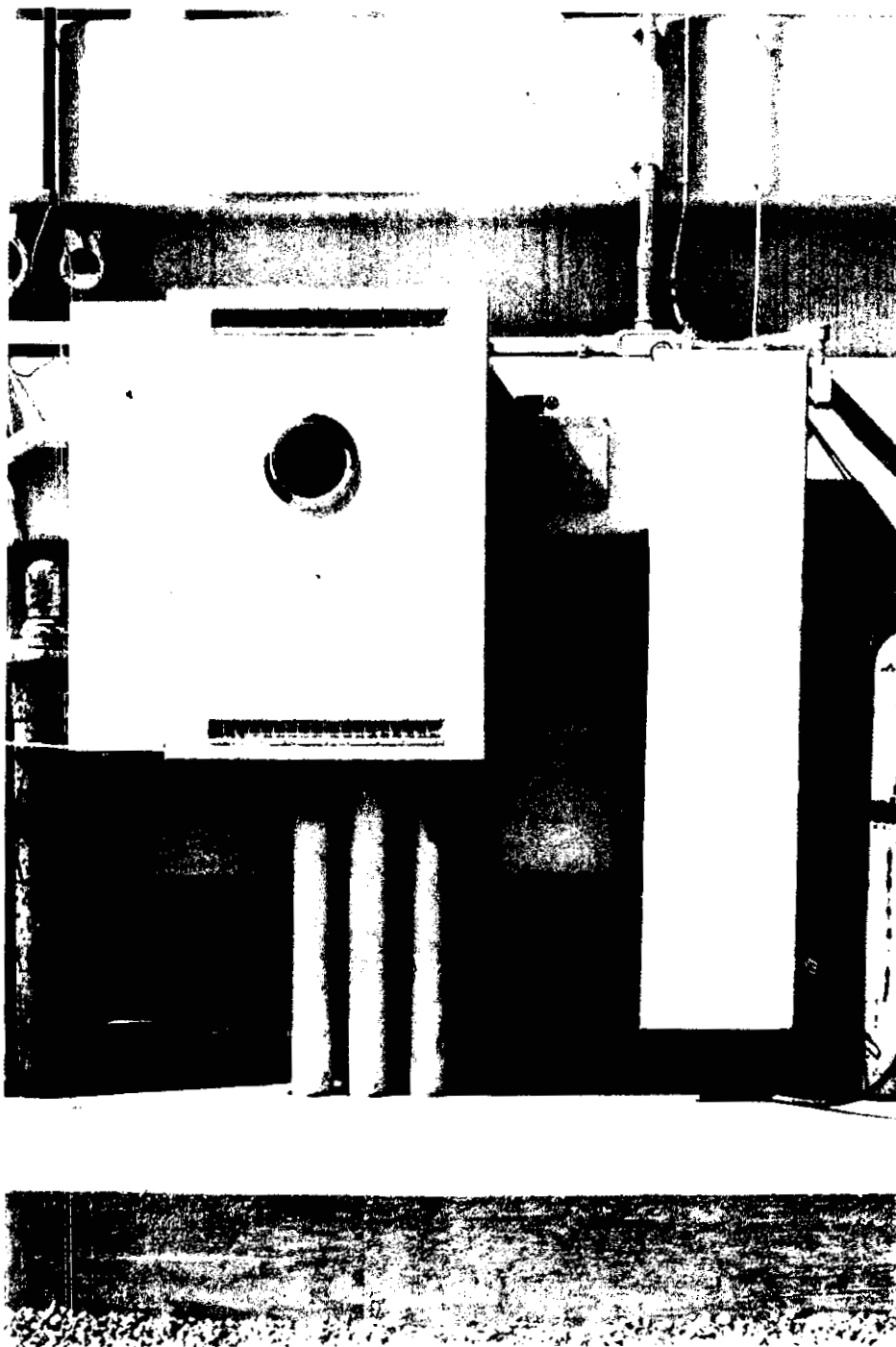

Picture 5: 480-V power distribution panel board on 150-MVA transformer



Picture 6: View of existing radiators and fans on 150-MVA transformer
(Note proximity to potential device supports)

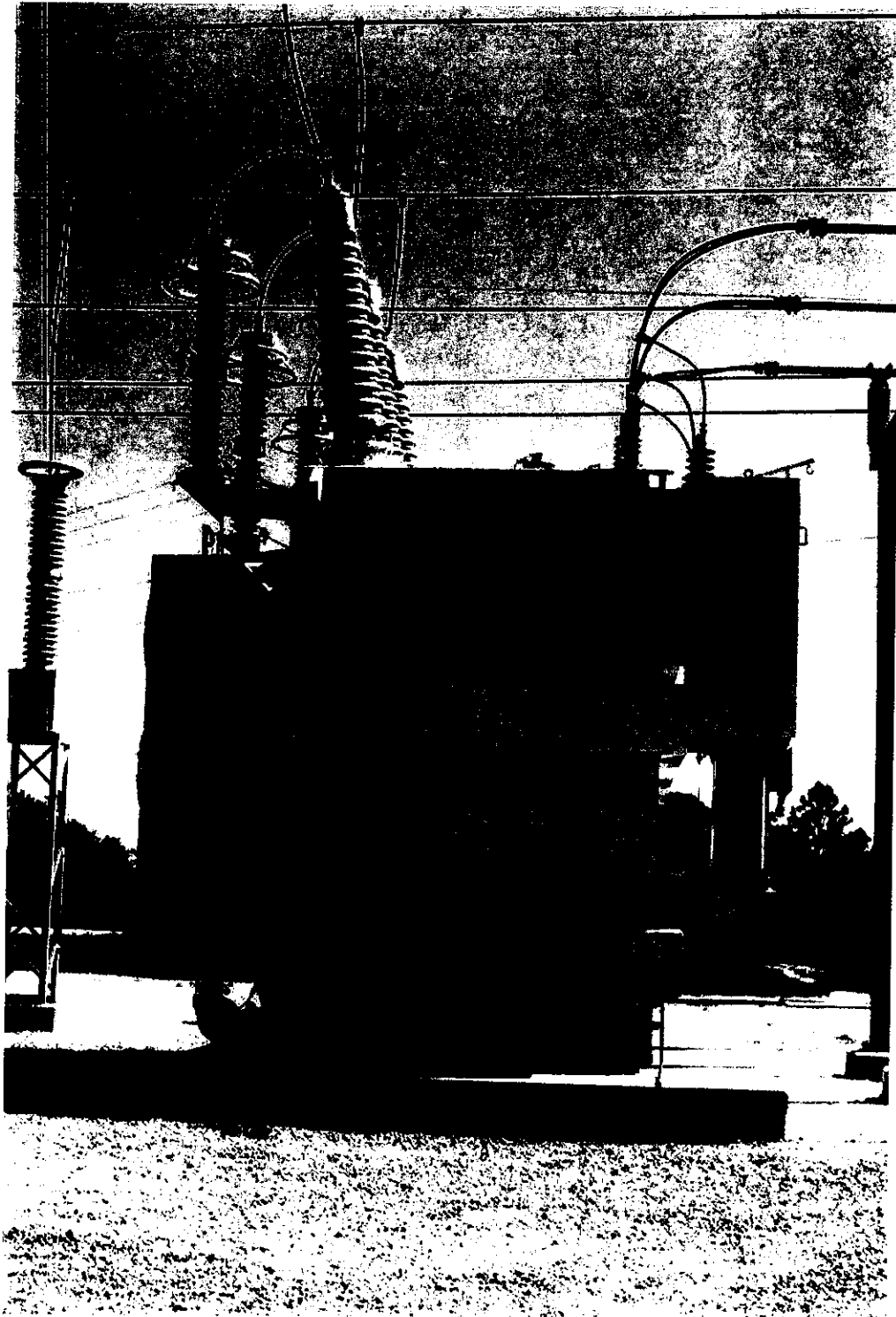

Picture 7: West side of 150-MVA transformer. Potential location for new auxiliary cooling devices.

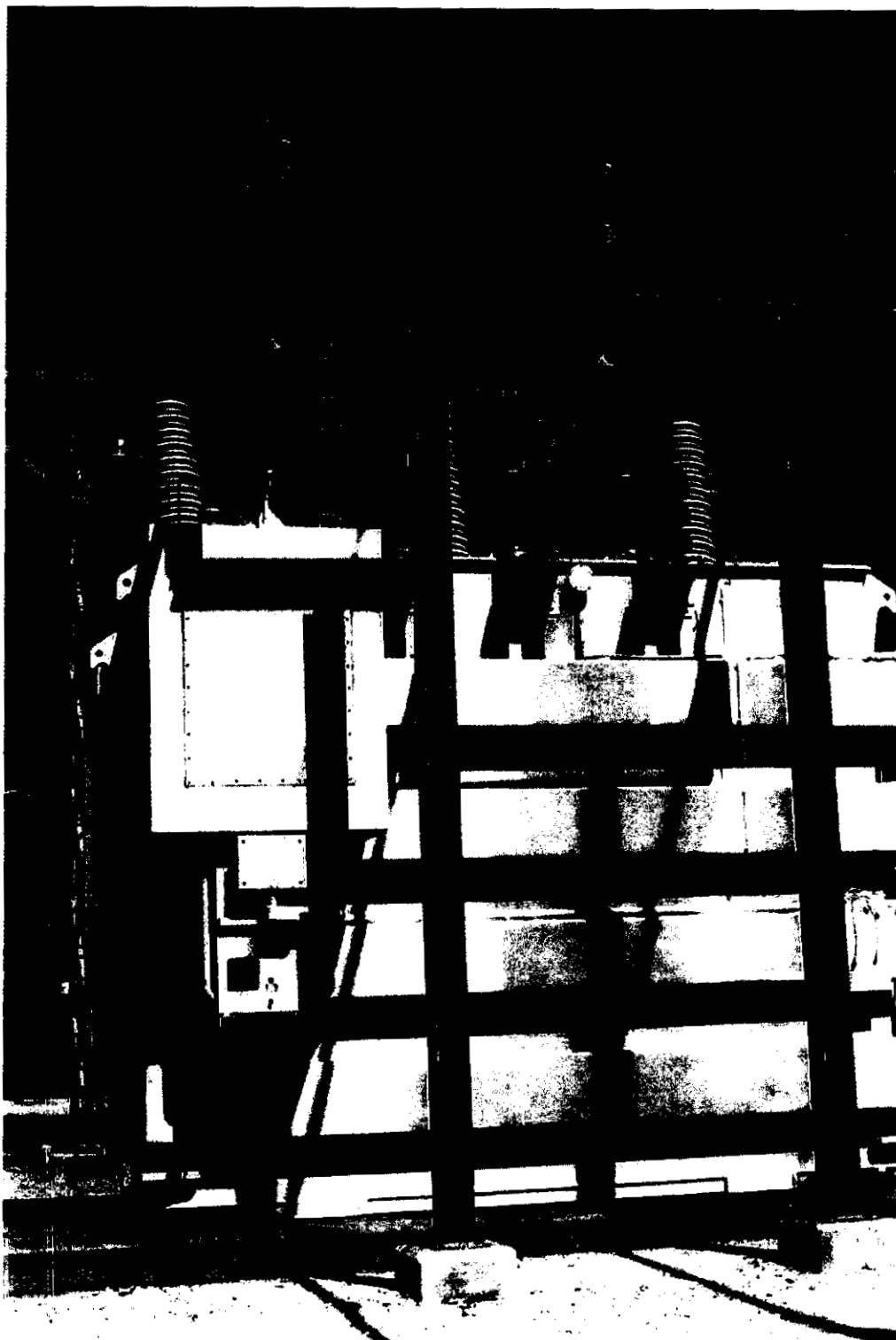

Picture 8: South side of 150-MVA transformer showing LTC.



Picture 9: South side of 150-MVA transformer

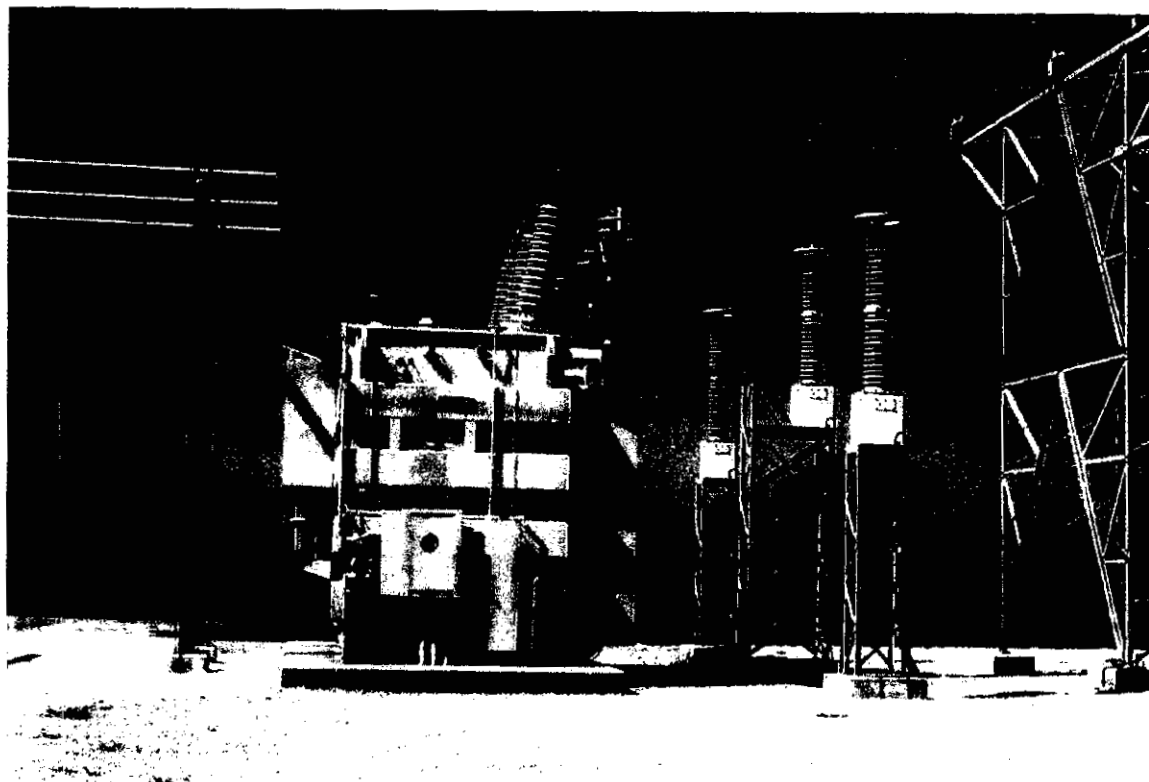

Picture 10: East side of 150-MVA transformer showing bus arrangement and surrounding facilities

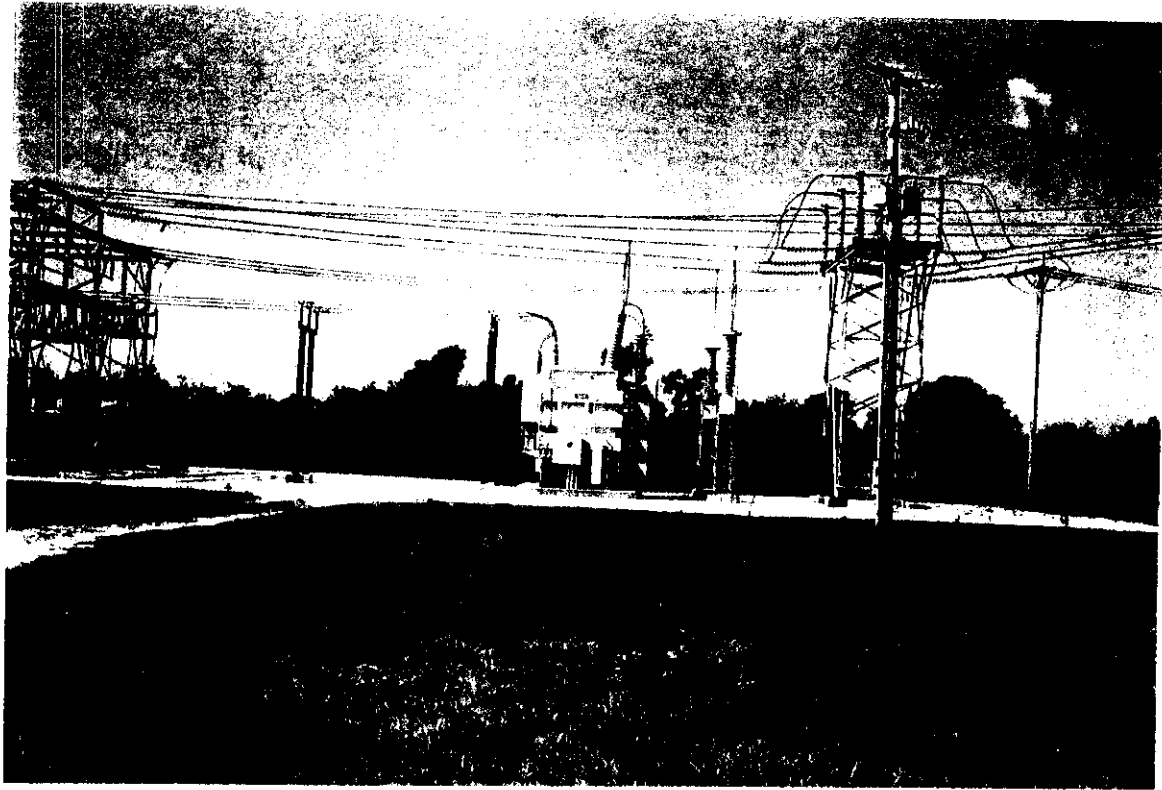

Picture 11: Panoramic view of Ariana Substation

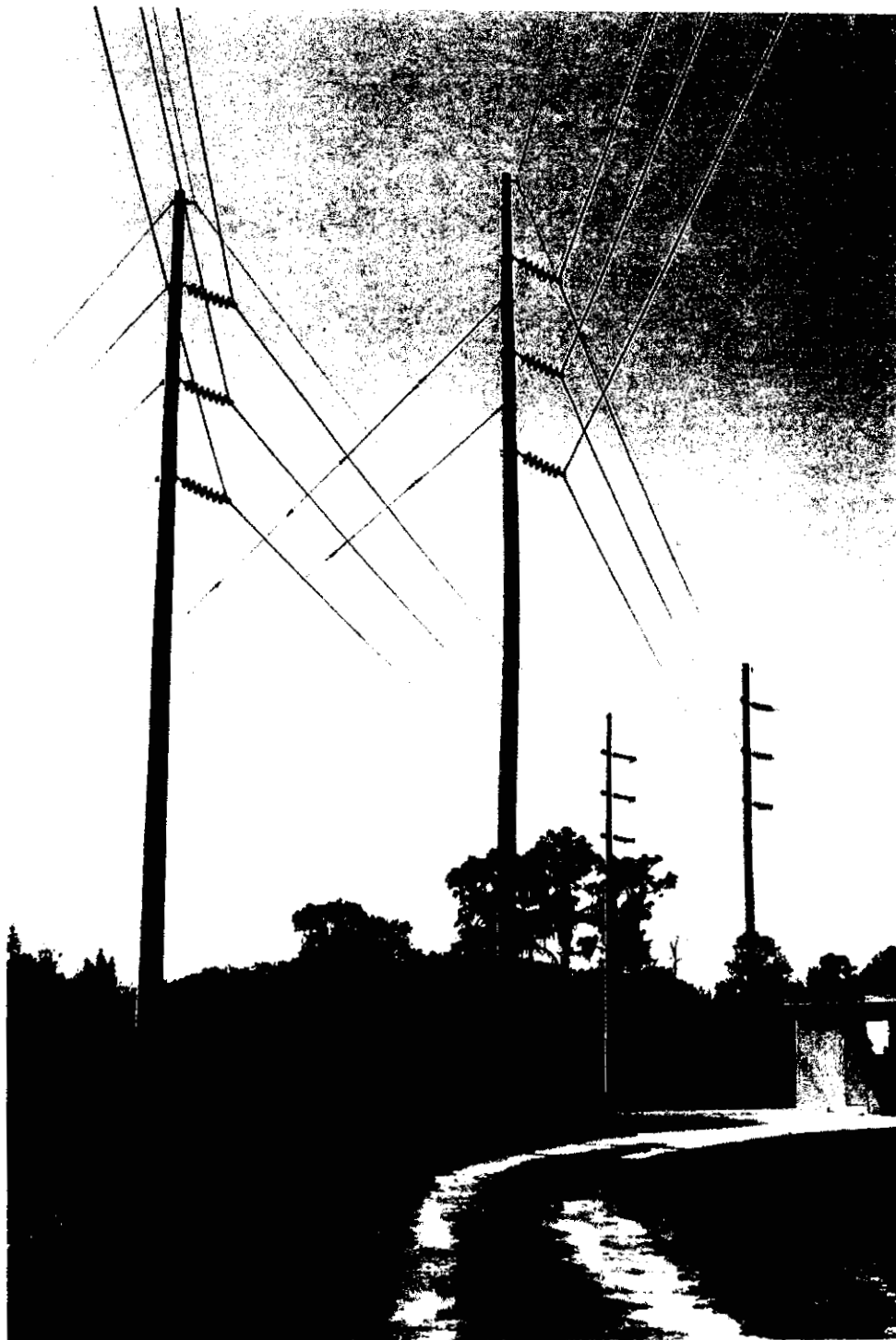

Picture 12: Typical single pole wood and concrete angle structures

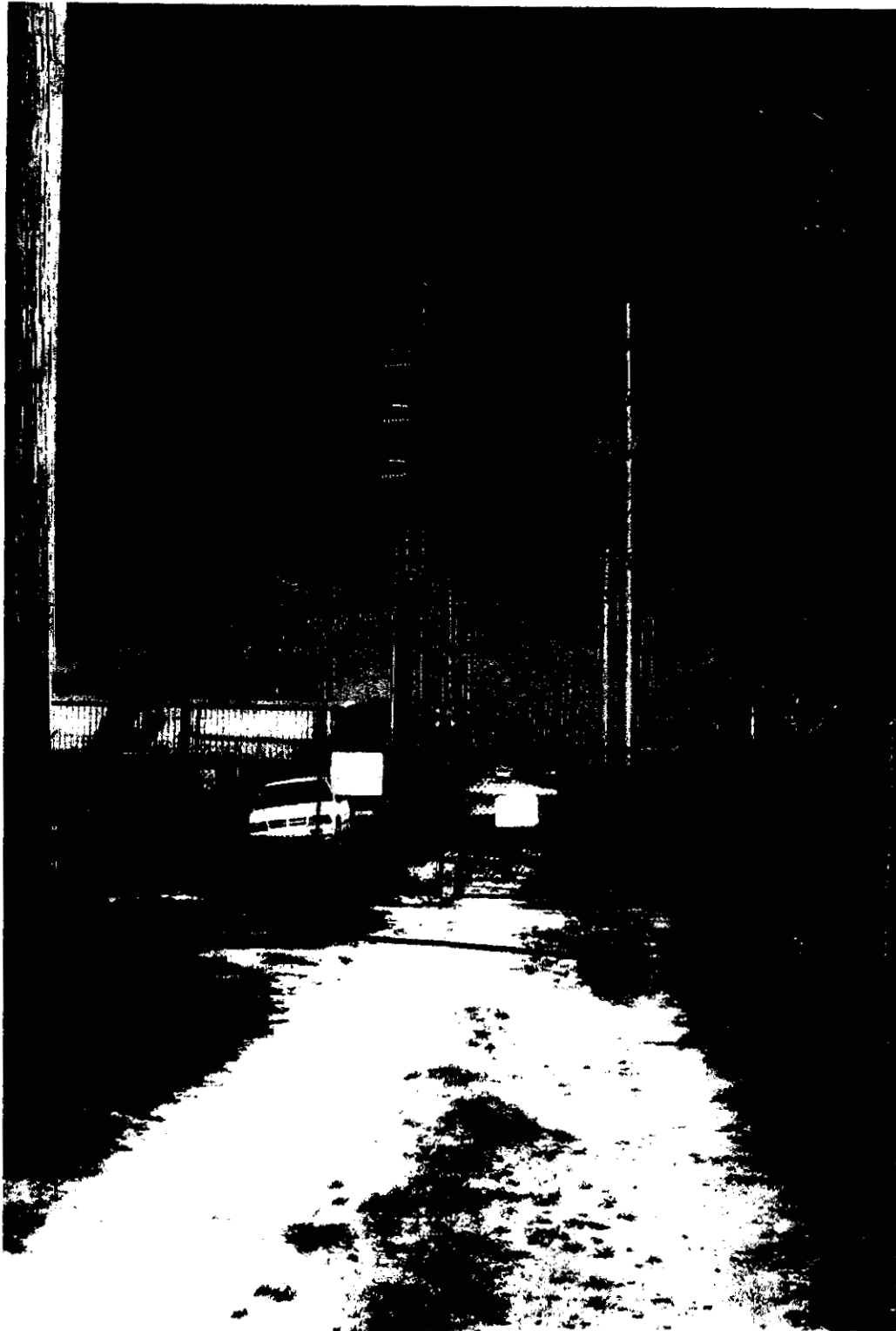

Picture 13: Access road to Ariana Substation. Background shows typical single pole wood and concrete corner structures.

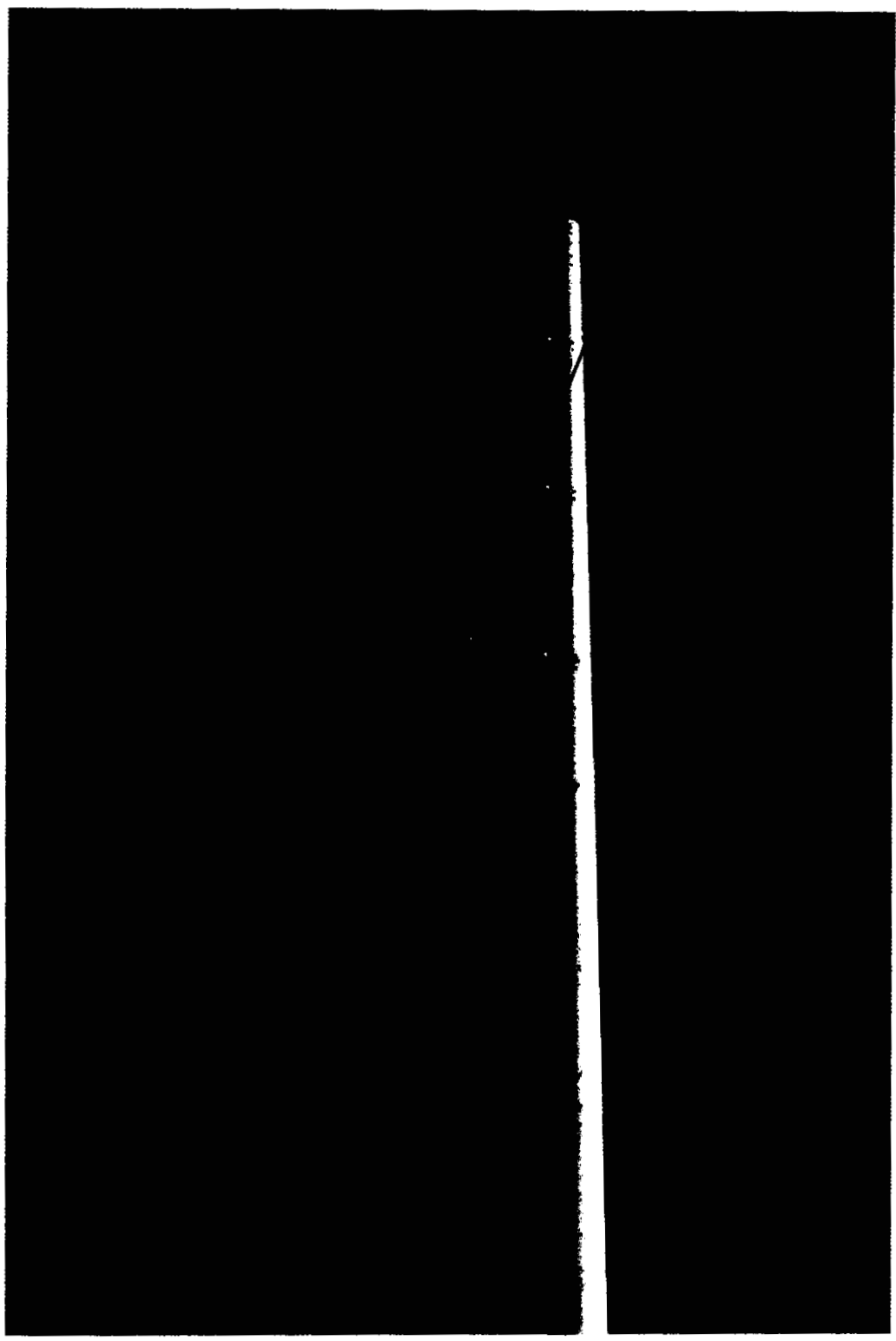

Picture 14: Typical single pole concrete tangent structure

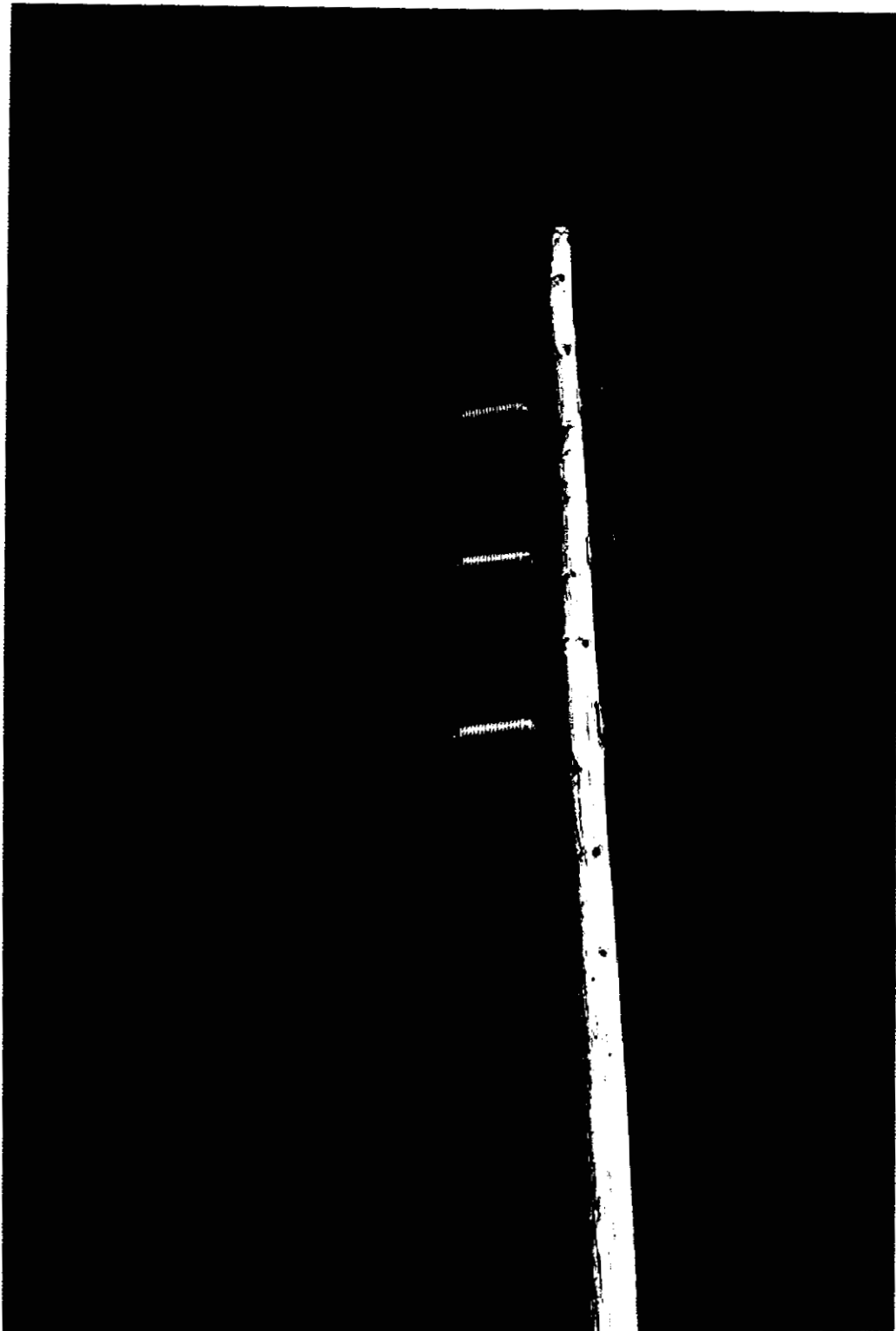

Picture 15: Typical single pole wood tangent structure

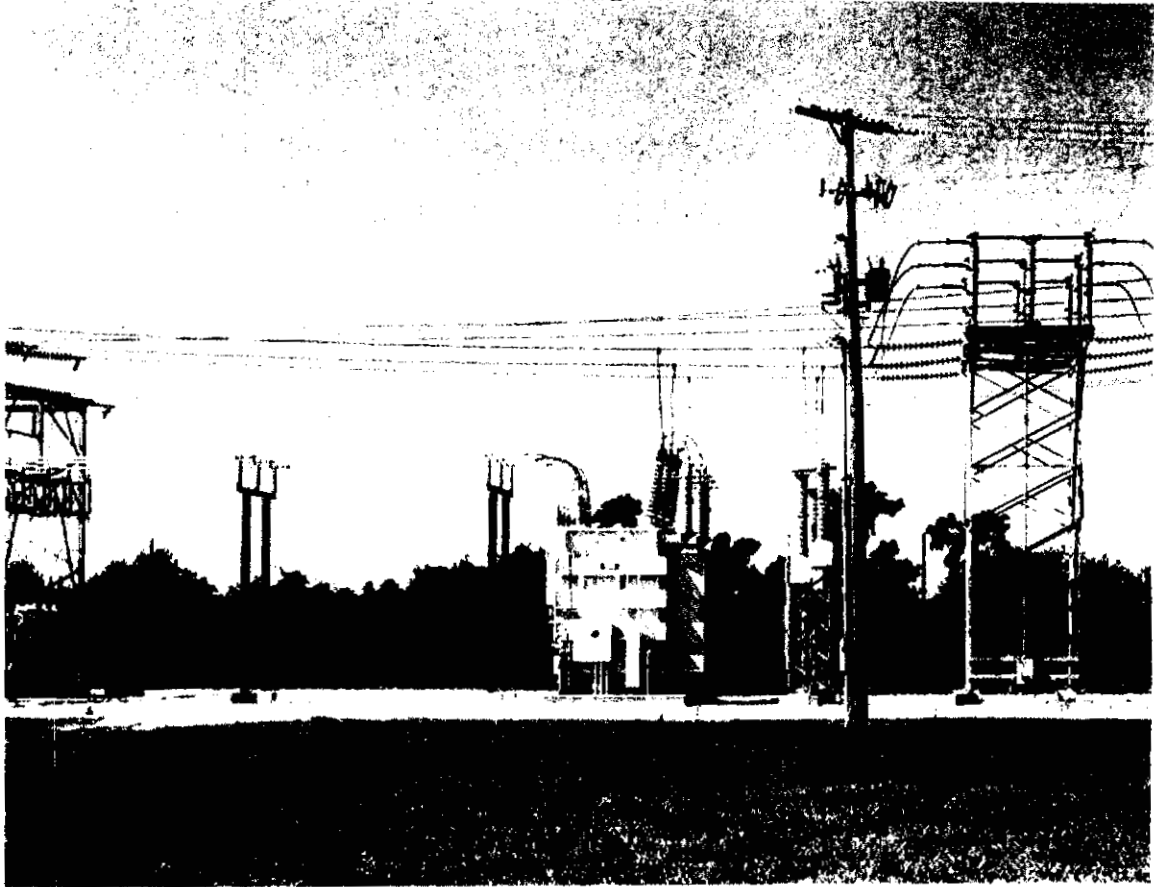

Picture 16: Panoramic view of Ariana Substation



Picture 17: Panoramic view of Ariana Substation

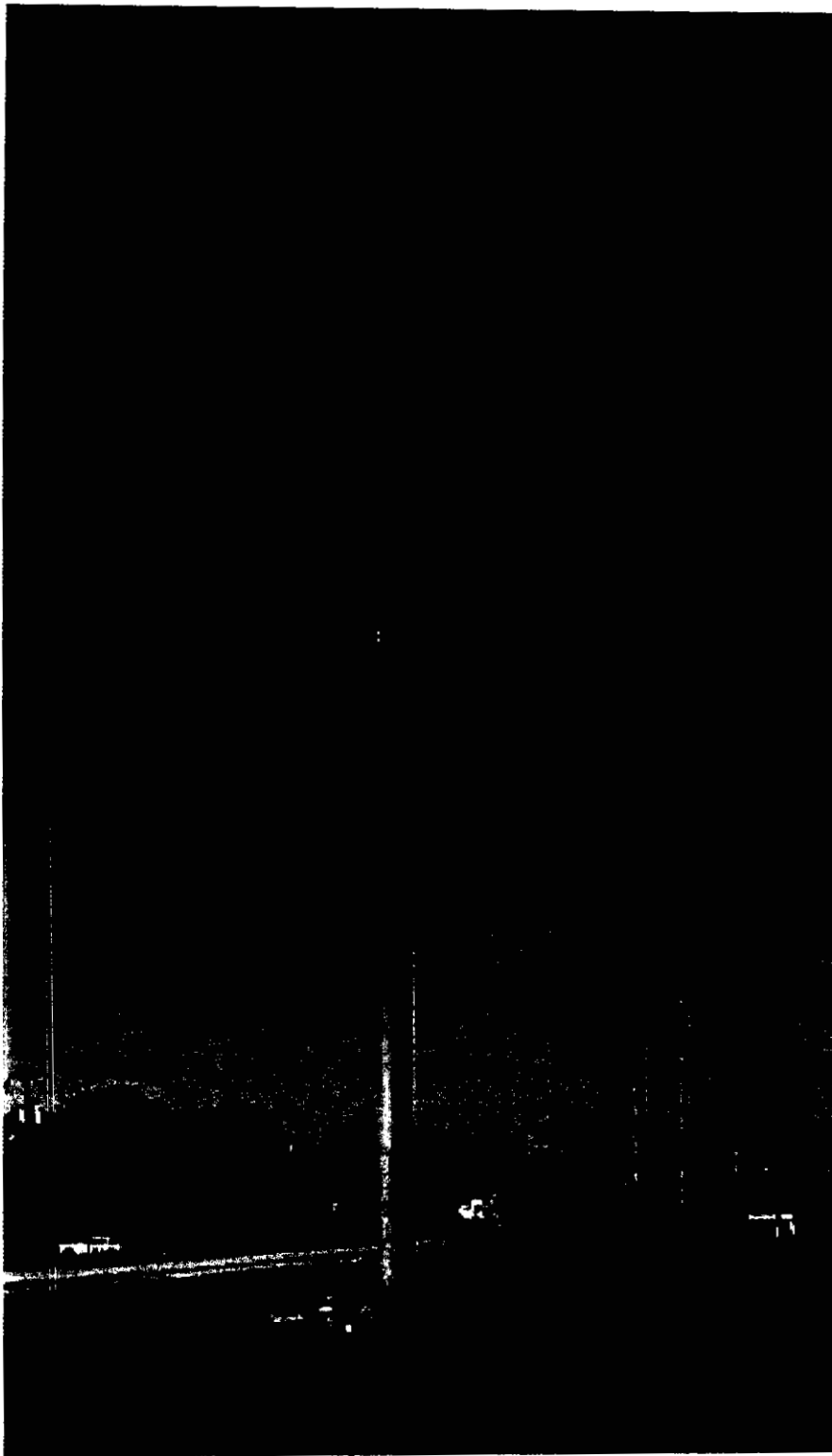

Picture 18: Typical single pole tubular steel tangent structure



Picture 19: Typical single pole tubular steel corner structure

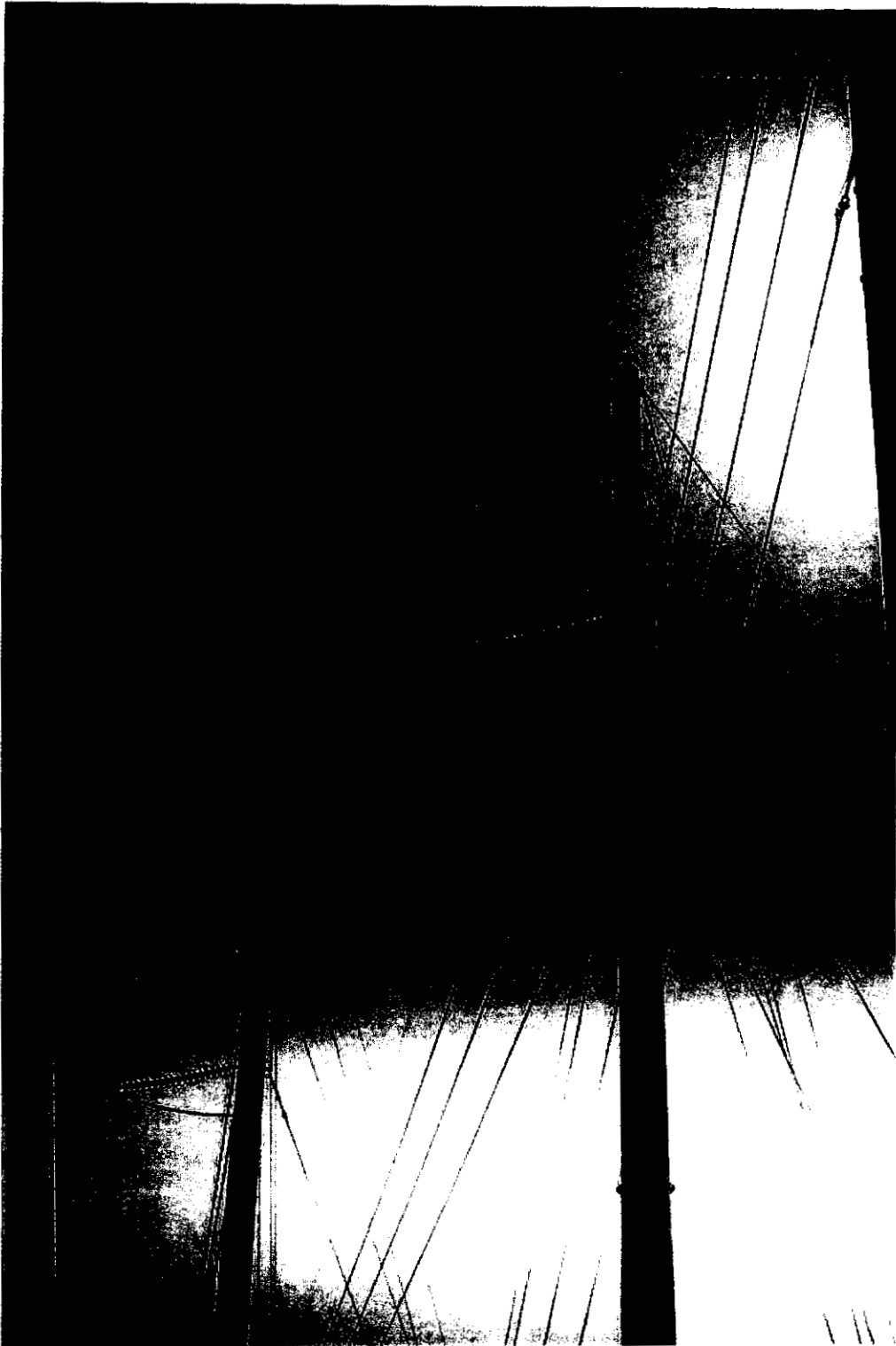

Picture 20: Pole top framing for single pole tubular steel corner structure

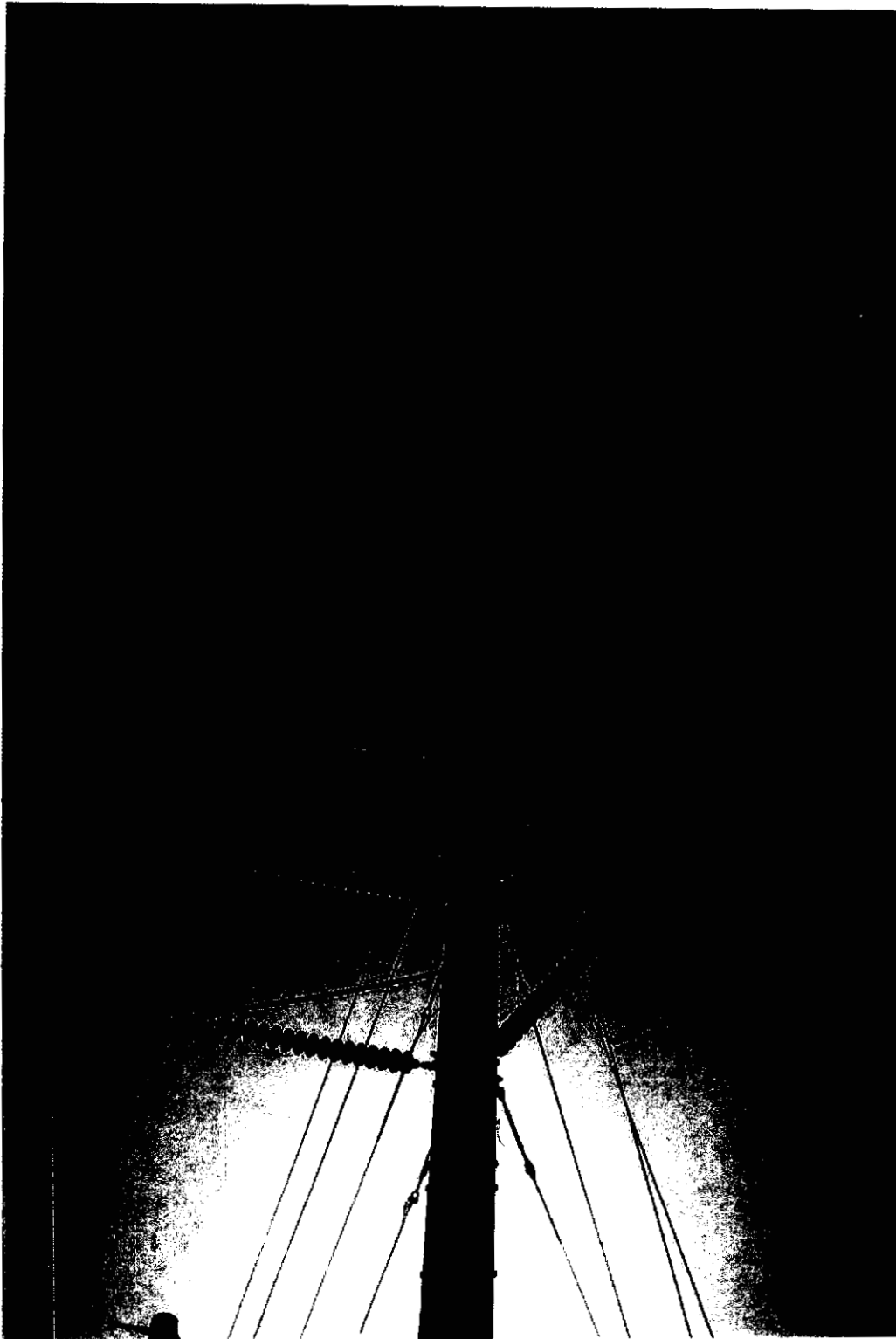

Picture 21: Pole top framing for single pole tubular steel corner structure

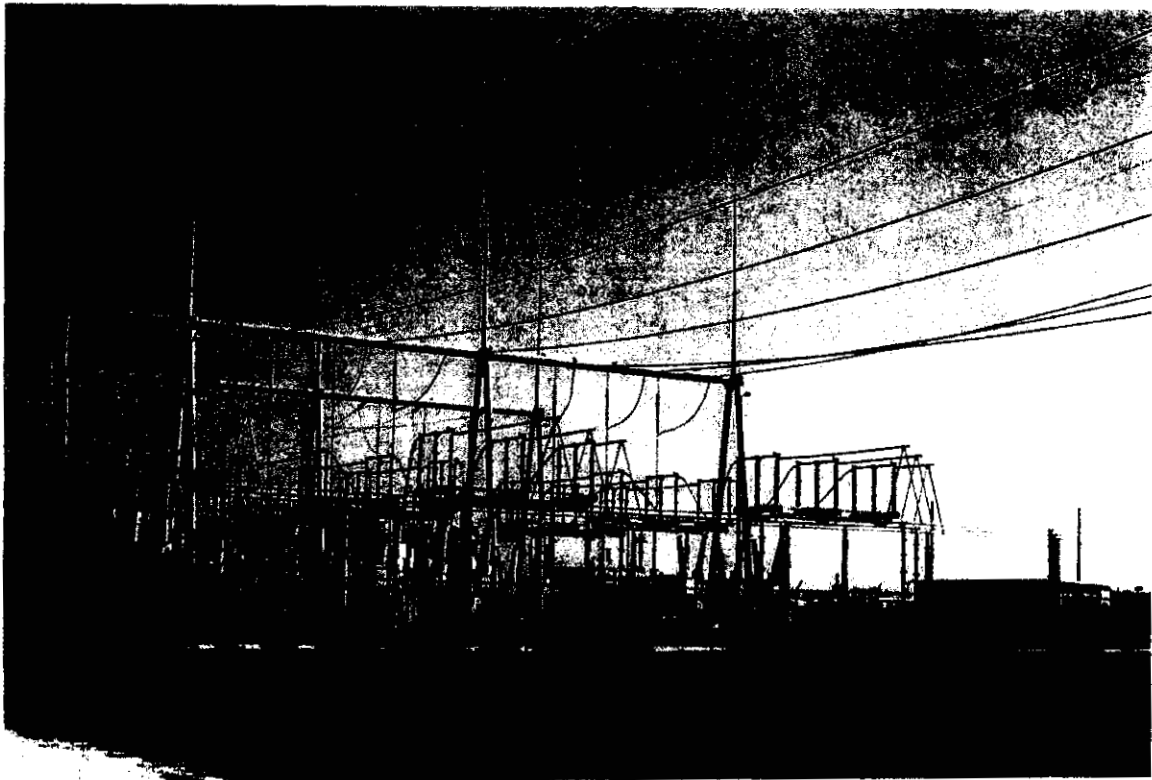

Picture 22: East half of Recker Substation

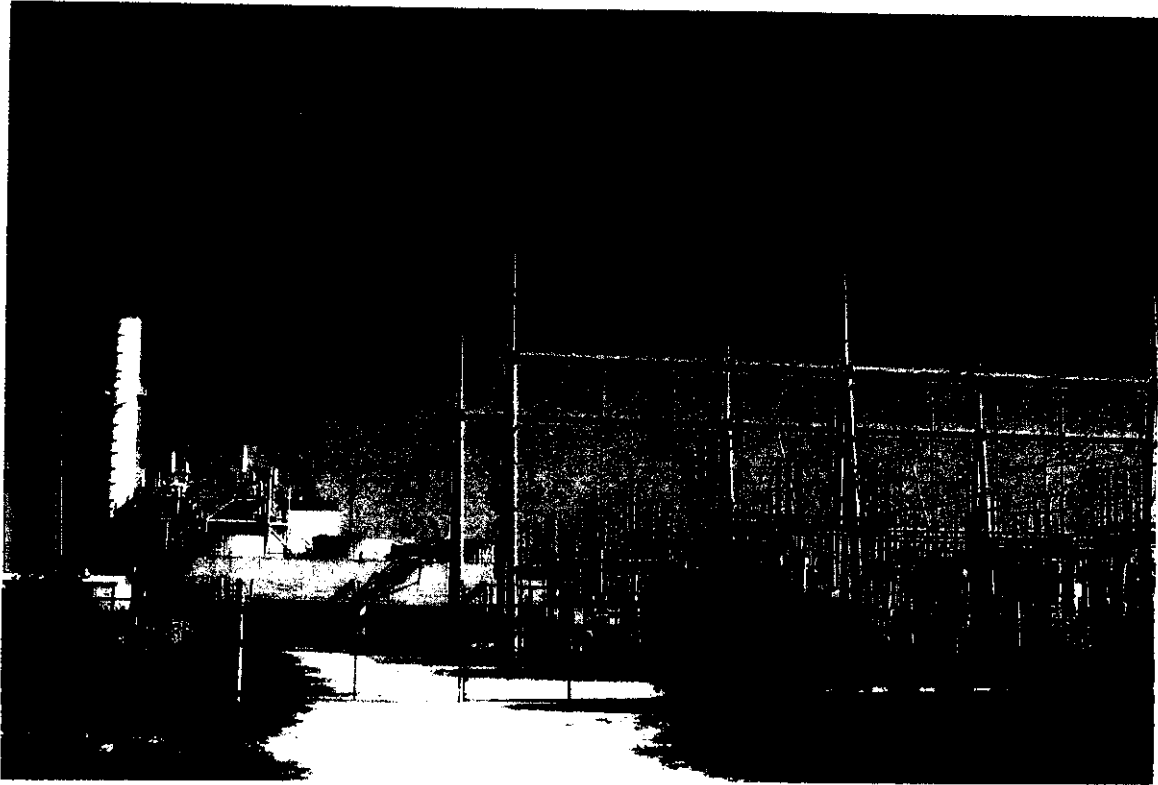

Picture 23: West half of Recker Substation



Picture 24: Typical single pole tubular steel tangent structure in Recker to Lake Agnes 230-kV line

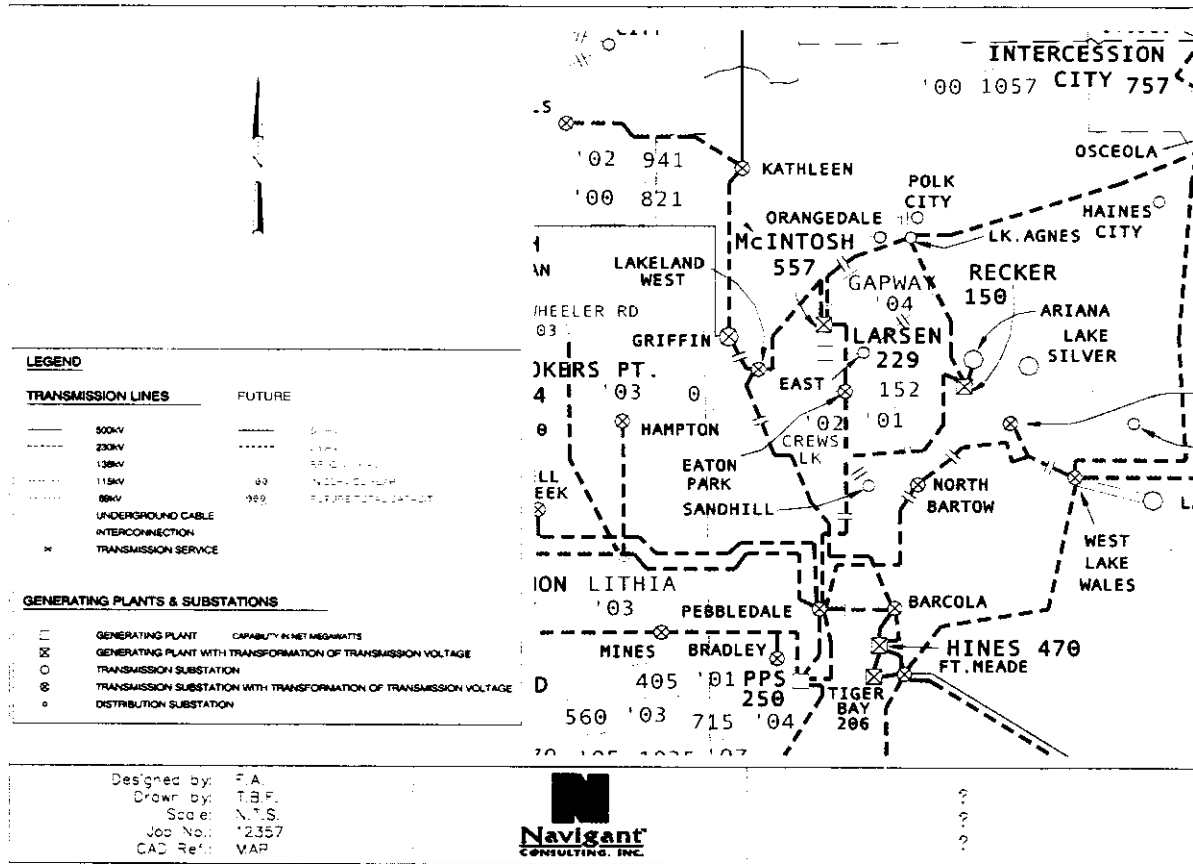

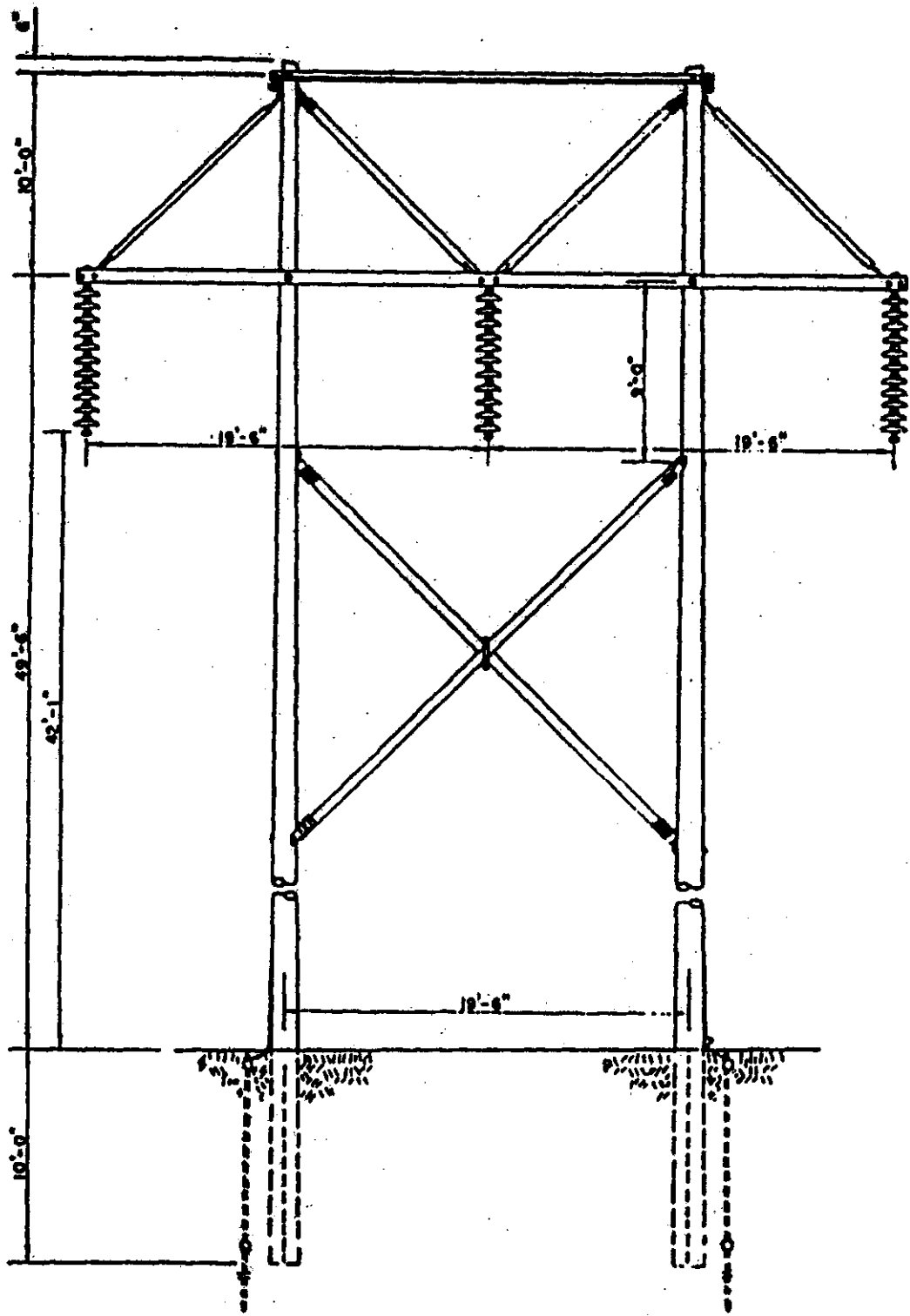

**REGIONAL TRANSMISSION MAP
OF WEST CENTRAL FLORIDA**

FPSC Docket No. 000442-EI
Calpine Construction Finance Co., L.P.
Witness: Armand
Exhibit (MPA-4)

