



ORIGINAL

RECEIVED-FPSC
01 APR -2 PM 4:12
RECORDS AND REPORTING

April 2, 2001

Ms. Blanca S. Bayo
Florida Public Service Commission
Director, Division of Records and Reporting
2540 Shumard Oak Blvd.
Tallahassee, Florida 32399-0850

undocketed

VIA HAND DELIVERY

Dear Ms. Bayo:

In accordance with Chapter 186, Section 186.801 (Ten Year Power Plant Site Plans) of the Florida Statutes, enclosed for filing are twenty-five (25) copies of Florida Power & Light Company's Ten-Year Power Plant Site Plan.

If you have any questions, please do not hesitate to contact me at (305) 552-4332 or Richard Rump at (305) 552-4159.

Sincerely,

Anne Grealy/dc
Anne Grealy, Director
Regulatory Affairs Department

- APP _____
 - CAF _____
 - CMP _____
 - CC:M _____
 - CTR _____
 - ECR _____
 - LEG _____
 - OPC _____
 - PAI _____
 - RGO _____
 - SEC _____
 - SER _____
 - OTH _____
- AG/rcr
Enclosures
- Habs*

RECEIVED & FILED
[Signature]
FPSC-BUREAU OF RECORDS

DOCUMENT NUMBER - DATE
04079 APR-26
FPSC-RECORDS/REPORTING

**Ten Year Power Plant Site Plan
2001 - 2010**



FPL

DOCUMENT NUMBER-DATE

04079 APR-26

FPSC-RECORDS/REPORTING



FPL

Ten Year Power Plant Site Plan

2001-2010

Submitted To:

***Florida Public
Service Commission***

***Miami, Florida
April, 2001***

(This page is intentionally left blank)

Table of Contents

List of Figures and Tables.....	iii
List of Schedules.....	v
Overview of the Document	1
List of Abbreviations Used in FPL Forms.....	3
Executive Summary	5
I. Description of Existing Resources	9
A. FPL-Owned Resources	11
B. Non-Utility Generation	15
C. Demand Side Management (DSM)	17
D. Purchased Power	18
II. Forecast of Electric Power Demand	23
A. Long-Term Sales Forecasts	26
B. Net Energy for Load	28
C. System Peak Forecasts	29
D. Hourly Load Forecast	30
III. Projection of Incremental Resource Additions	39
A. FPL's Resource Planning	41
B. Incremental Resource Additions	47
C. Demand Side Management (DSM)	51
D. Non-Utility Generation Additions	55
E. Transmission Plan	56
F. Renewable Resources	73
G. FPL's Fuel Mix and Price Forecasts	75
IV. Environmental and Land Use Information	109
A. Protection of the Environment	111
B. FPL's Environmental Statement	111
C. Environmental Management	112
D. Environmental Assurance Program	112
E. Environmental Communication and Facilitation	113
F. Preferred and Potential Sites	113
V. Other Planning Assumptions and Information	169
Introduction	171
Discussion Item #1	171

Table of Contents

Discussion Item #2	172
Discussion Item #3	174
Discussion Item #4	175
Discussion Item #5	175
Discussion Item #6	176
Discussion Item #7	177
Discussion Item #8	177
Discussion Item #9	179
Discussion Item #10	179
Discussion Item #11	181
Discussion Item #12	181
VI. Summary of Required Schedules	183
Ten Year Site Plan Fact Summary	227

List of Figures and Tables

Table ES.1	Projected Capacity Changes and Reserve Margins for FPL	7
Figure I.A.1	Capacity Resources (Map)	12
Figure I.A.2	FPL Substation & Transmission System Configuration (Map)	13
Figure I.A.3	FPL Interconnection Diagram	14
Table I.B.1	Florida Power & Light Company Firm Capacity and Energy Contracts with Cogenerators/Small Power Production Facilities	16
Table I.B.2	As-Available Energy Purchases From Non-Utility Generators in 2000	17
Table I.D.1	FPL's Purchased Power MW	18
Figure III.A.1	Overview of FPL's IRP Process	42
Table III.B.1	Projected Capacity Changes for FPL	49
Table III.C.1	FPL's Summer MW Reduction Goals for DSM	55
Table III.E.1	List of Proposed Power Lines	56
Figure III.E.1	Martin Plant Combustion Turbines	58
Figure III.E.2	Fort Myers Repowering Project	60
Figure III.E.3	Sanford Repowering Project	62
Figure III.E.4	Fort Myers Combustion Turbines	64
Figure III.E.5	Martin Combined Cycle Units	66
Figure III.E.6	Martin Conversion of CT's to CC	68
Figure III.E.7	Fort Myers Conversion of CT's to CC	70
Figure III.E.8	Midway Combined Cycle Units	72
Table IV.E.1	2000 FPL Environmental Outreach Activities	113
	Fort Myers	141
	Figure IV.F.1 U.S. Geological Survey (USGS) Map	143
	Figure IV.F.2 U.S. Geological Survey (USGS) Legend	144
	Figure IV.F.3 Proposed Facilities Layout Map	145
	Figure IV.F.4 Map of Site and Adjacent Area	146

List of Figures and Tables

Sanford		147
	Figure IV.F.5 U.S. Geological Survey (USGS) Map	149
	Figure IV.F.6 Proposed Facilities Layout Map	150
	Figure IV.F.7 Map of Site and Adjacent Area	151
Martin		153
	Figure IV.F.8 U.S. Geological Survey (USGS) Map	155
	Figure IV.F.9 U.S. Geological Survey (USGS) Legend ...	156
	Figure IV.F.10 Proposed Facilities Layout Map	157
	Figure IV.F.11 Map of Site and Adjacent Area	158
Midway		159
	Figure IV.F.12 Proposed Facilities Layout Map	161
	Figure IV.F.13 Map of Site and Adjacent Area	162
Potential Sites		163
	Figure IV.F.14 U.S. Geological Survey (USGS) Map	165
	(Port Everglades)	
	Figure IV.F.15 U.S. Geological Survey (USGS) Map	166
	(Cape Canaveral)	
	Figure IV.F.16 U.S. Geological Survey (USGS) Map	167
	(Riviera)	
Table V.1-Selected Power Plant Construction Options		
For Base and Sensitivity Cases		173

List of Schedules

Schedule 1	Existing Generating Facilities.....	19
Schedule 2.1	History and Forecast of Energy Consumption & Number of Customers by Customer Class.....	31
Schedule 2.2	History and Forecast of Energy Consumption & Number of Customers by Customer Class.....	32
Schedule 2.3	History and Forecast of Energy Consumption & Number of Customers by Customer Class.....	33
Schedule 3.1	History and Forecast of Summer Peak Demand (Base Case).....	34
Schedule 3.2	History and Forecast of Winter Peak Demand (Base Case).....	35
Schedule 3.3	History and Forecast of Annual Net Energy for Load GWH (Base Case)	36
Schedule 4	Previous Year Actual and Two-Year Forecast of Retail Peak Demand and Net Energy for Load by Month	37
Schedule 5	Fuel Requirements.....	77
Schedule 6.1	Energy Sources	78
Schedule 6.2	Energy % by Fuel Type.....	79
Schedule 7.1	Forecast of Capacity, Demand and Scheduled Maintenance at Time of Summer Peak.....	80
Schedule 7.2	Forecast of Capacity, Demand and Scheduled Maintenance at Time of Winter Peak.....	81
Schedule 8	Planned and Prospective Generating Facility Additions and Changes	82
Schedule 9	Status Report and Specifications of Proposed Generating Facilities	86
Schedule 10	Status Report and Specifications of Proposed Directly Associated Transmission Lines	99

(This page is intentionally left blank)

Overview of The Document

Chapter 186, Florida Statutes, requires that each electric utility in the State of Florida with a minimum existing generating capacity of 250 megawatts (MW) must annually submit a Ten - Year Power Plant Site Plan. This plan includes an estimate of the utility's electric power generating needs, a projection of how those needs will be met, and a disclosure of information pertaining to the utility's preferred and potential power plant sites. This information is compiled and presented in accordance with rules 25-22.070, 25-22.071, and 25-22.072, Florida Administrative Code (FAC).

This Ten - Year Power Plant Site Plan (Site Plan) document is based on Florida Power & Light Company's (FPL) 2000 planning analyses and the forecasted information presented in this plan addresses the 2001 – 2010 time frame.

Site Plans are long-term planning documents and should be viewed in this context. A Site Plan contains tentative information, especially for the latter years of the ten - year time horizon, and is subject to change at the discretion of the utility. Much of the data submitted is preliminary in nature and is presented in a general manner. Specific and detailed data will be submitted as part of the Florida site certification process, or through other proceedings and filings.

This document is organized in the following manner:

Chapter I – Description of Existing Resources

This chapter provides an overview of FPL's current generating facilities. Also included is data on other FPL resources, including its transmission system.

Chapter II – Forecast of Electric Power Demand

FPL's load forecasting methodology, and its forecast of seasonal peaks and annual energy usage, are presented in Chapter II.

Chapter III – Projection of Incremental Resource Additions

This chapter discusses FPL's integrated resource planning (IRP) process and outlines FPL's projected resource additions, especially new power plants, as determined in FPL's 2000 IRP work.

Chapter IV – Environmental and Land Use Information

This chapter discusses various environmental information as well as preferred and potential site locations for additional electric generation facilities.

Chapter V – Other Planning Assumptions and Information

This chapter addresses twelve "discussion items" which pertain to additional specific information which is to be included in a Site Plan filing.

Chapter VI – Summary of Required Schedules

This chapter contains Schedules 1 through 10. It also contains FPL's Ten Year Site Plan Fact Summary.

FPL
List of Abbreviations
Used in FPL Forms

<i>Reference</i>	<i>Abbreviation</i>	<i>Definition</i>
Unit Type	IC	Internal Combustion
	NP	Nuclear Power
	ST	Steam Unit
	GT	Gas Turbine
	CT	Combustion Turbine
	CC	Combined Cycle
	BIT	Bituminous Coal
Fuel Type	UR	Uranium
	NG	Natural Gas
	FO6	#4,#5,#6 Oil (Heavy)
	FO2	#1, #2 or Kerosene Oil (Distillate)
	BIT	Bituminous Coal
	No	None
Fuel Transportation	TK	Truck
	RR	Railroad
	PL	Pipeline
	WA	Water
	No	None
Air Pollution Control	LNB	Low No _x Burners
Cooling Method Type	OTS	Once Through - Saline
	CP	Cooling Pond
Unit/Site Status	P	Planned Unit
	A	Generation Unit Capability Increased (Rerated or Relicensed)

(This page is left intentionally blank)

Executive Summary

Florida Power & Light Company's (FPL) 2001 Ten - Year Power Plant Site Plan (Site Plan) primarily addresses FPL's plans to increase its electric generation capability as part of its efforts to meet its projected incremental resource needs for the 2001 – 2010 time period.

FPL's total generation capability will significantly increase during the 2001 – 2010 time period as is shown in Table ES.1. This table also shows the resulting Summer and Winter reserve margins for FPL over the ten-year time horizon.

Table ES 1 reflects FPL's efforts to repower existing units at its Fort Myers and Sanford sites, its approved DSM goals, planned changes to existing generation units (due to unit overhauls, etc.); and scheduled changes in the delivered amounts of purchased power. The table also reflects the planned additions of new generating units.

The number of these new generating units that will be added is driven in part by the outcome of the Florida Public Service Commission docket No. 981890-EU. This docket ended with a stipulated agreement that primarily resulted in FPL, along with Tampa Electric Company and Florida Power Corporation, switching from a minimum reserve margin planning criterion of 15% to one of 20% beginning with the Summer of 2004. As a consequence, FPL is now planning to add significantly more new generation capacity than was shown in its Site Plans filed prior to this agreement.

As shown in Table ES.1, FPL plans to add four new combustion turbines (CT's) in the 2001 – 2003 time period. Two new CT's will be installed at FPL's existing Martin plant site in 2001. Another two new CT's will be installed at FPL's existing Fort Myers plant site in 2003. All four CT's are projected to be converted into combined cycle (CC) units in 2005. As a result, the pair of new CT's at Martin and the pair of new CT's at Fort Myers will each be converted into one new CC unit. The resulting new CC unit at Martin, and the new CC unit at Fort Myers, will begin operation in 2005.

Also during the 2001 – 2003 time period, FPL will be repowering its two existing steam units at its Fort Myers site and will be repowering two (unit Nos. 4 & 5) of its existing three steam units at its Sanford site.

FPL is also securing capacity for the time period from mid-2001 to mid-2005 through a number of new firm capacity, short-term purchases from utilities and other entities. (Please see Chapter III for a further discussion of these new purchases.)

In addition, eight combined cycle (CC) units will be added during the 2005 – 2010 time period.¹ Two CC units will be added at FPL's Martin plant site, one in 2005 and one in 2006. Another CC unit is projected to be added at FPL's Midway site in 2005. In addition, one new CC unit will be added in 2007 and another in 2009. Finally, three new CC units will be added in 2010 as FPL's UPS contract with Southern Company ends.² Sites for the last five CC units for the 2007 – 2010 time frame have not yet been selected.

These planned increases in electric generation capability will allow FPL to continue to maintain system reliability and integrity at a reasonable cost.

¹ FPL's current planning studies have identified new combined cycle units as the generally preferred option to meet future load growth. However, repowering of existing FPL sites remains an alternative to new construction, and FPL will continue to examine this option.

² FPL has not yet determined whether it would extend or replace these purchases, or build new capacity to meet its needs. For purposes of this Site Plan it was assumed that the 2010 needs would be met through the addition of unsited CC units. A final decision regarding the 2010 needs is not needed for at least several years.

Projected Capacity Changes and Reserve Margins for FPL ⁽¹⁾

	<u>Net Capacity Changes (MW)</u>		<u>FPL Reserve Margin (%)</u>	
	<u>Winter ⁽²⁾</u>	<u>Summer ⁽³⁾</u>	<u>Winter</u>	<u>Summer</u>
2001 Changes to existing plants	8	(56)	18%	20%
Fort Myers Repowering:Initial Phase ⁽⁴⁾	543	894		
Combustion Turbines (2) at Martin ⁽⁵⁾	---	298		
New purchases ⁽⁶⁾	---	196		
2002 Fort Myers Repowering:Second Phase	(1)	35	15%	22%
Combustion Turbines (2) at Martin ⁽⁵⁾	362	---		
Sanford Repowering # 5: Initial Phase ⁽⁷⁾	(394)	---		
Sanford Repowering # 5: Second Phase ⁽⁷⁾	---	567		
Sanford Repowering # 4: Initial Phase ⁽⁷⁾	---	(390)		
New purchases ⁽⁶⁾	50	779		
Changes to existing QF's	---	(9)		
2003 Fort Myers Repowering:Second Phase	531	---	29%	25%
Sanford Repowering # 5: Second Phase	1065	---		
Sanford Repowering # 4: Second Phase	671	957		
Combustion Turbines (2) Fort Myers ⁽⁸⁾	---	298		
Changes to existing QF's	(9)	---		
New purchases ⁽⁶⁾	1025	---		
2004 Combustion Turbines (2) Fort Myers	362	---	28%	22%
2005 Changes to existing QF's	(10)	(10)	25%	23%
New purchases ⁽⁶⁾	(50)	(975)		
Martin Combined Cycle No. 5 ⁽⁹⁾	---	547		
Conversion of MR CT's to CC	---	249		
Conversion of FM CT's to CC	---	249		
Midway Combined Cycle ⁽⁹⁾	---	547		
2006 Changes to existing QF's	(133)	(133)	25%	22%
New purchases	(1025)	---		
Martin Combined Cycle No. 5 ⁽⁹⁾	596	---		
Conversion of MR CT's to CC	234	---		
Conversion of FM CT's to CC	234	---		
Midway Combined Cycle ⁽⁹⁾	596	---		
Martin Combined Cycle No. 6 ⁽⁹⁾	---	547		
2007 Martin Combined Cycle No. 6 ⁽⁹⁾	596	---	26%	23%
Unsitd Combined Cycle #1 ⁽⁹⁾		547		
2008 Unsitd Combined Cycle #1 ⁽⁹⁾	596	---	27%	21%
2009 Unsitd Combined Cycle #2 ⁽⁹⁾	---	547	25%	21%
Changes to existing QF's	(51)	(51)		
2010 Changes to existing purchases ⁽¹⁰⁾	---	(975)	25%	21%
Unsitd Combined Cycle #2 ⁽⁹⁾	596	---		
Unsitd Combined Cycle #3 ⁽⁹⁾	---	547		
Unsitd Combined Cycle #4 ⁽⁹⁾	---	547		
Unsitd Combined Cycle #5 ⁽⁹⁾	---	547		
TOTALS =	6,392	6,299		

Table E.S. 1

Projected Capacity Changes and Reserve Margins for FPL

Note:

- (1) Additional information about these capacity changes and resulting reserve margins is found in Chapter III of this document.
- (2) Winter values are values for January of year shown.
- (3) Summer values are values for August of year shown.
- (4) The initial phase of the Fort Myers repowering project consists of the introduction of operational combustion turbines followed by taking existing steam units out-of-service. The second phase of repowering consists of completing the integration of the combustion turbines, heat recovery steam generators, and steam turbines.
- (5) The two CT's at Martin are scheduled to be in-service in the Summer of 2001. Therefore, the CT's are included in the 2001 Summer reserve margin calculation and are included in the 2002 - on reserve margin calculations for Summer and Winter.
- (6) These are firm capacity, short - term purchases. See Section I.D. and III.A. for more details.
- (7) The initial phase of the Sanford repowering project consists solely of taking existing steam units out-of-service; combustion turbine operation is not introduced at this time. The second phase of the repowering consists of integrating the combustion turbines, heat recovery steam generators, and steam turbines.
- (8) The two CT's at Fort Myers are scheduled to be in-service in the Spring of 2003. Therefore, the CT's are included in the 2003 Summer reserve margin calculation and are included in the 2004 - on reserve margin calculations for Summer and Winter.
- (9) All combined cycle units are scheduled to be in-service in June of the year shown. Consequently, they are included in the Summer reserve margin calculation for the in-service year and in both the Summer and Winter reserve margin calculations for subsequent years.
- 10) FPL will be determining at a later date whether to extend or replace these UPS purchases from Southern Company. However, for purposes of this Site Plan, FPL has assumed that the 2010 needs would be met through the addition of unsited combined cycles.

CHAPTER I

Description of Existing Resources

(This page is left intentionally blank.)

I. Description of Existing Resources

FPL's service area contains approximately 27,650 square miles and has a population of approximately 7.3 million people. FPL served an average of 3,848,401 customer accounts in thirty-five counties during 2000. These customers were served from a variety of resources including: FPL-owned fossil and nuclear generating units, non-utility-owned generation, demand side management, and interchange/purchased power.

I.A. FPL-Owned Resources

The existing FPL generating resources are located at fourteen generating sites distributed geographically around its service territory and also include partial ownership of one unit located in Georgia and two units located in Jacksonville. The current generating facilities consist of four nuclear steam units, three coal units, six combined cycle units, twenty-one fossil steam units, forty-eight gas turbines, and five diesel units. The location of these units is shown on Figure I.A.1.

The bulk transmission system is composed of 1,107 circuit miles of 500 Kilovolt (KV) lines (including 75 miles of 500 KV lines [two 37-1/2 mile lines] between Duval Substation and the Florida-Georgia state line, which are jointly owned with Jacksonville Electric Authority) and 2,572 circuit miles of 230 KV lines. The underlying network is composed of 1,614 circuit miles of 138 KV lines, 717 circuit miles of 115 KV lines, and 180 circuit miles of 69 KV transmission lines. Integration of the generation, transmission, and distribution system is achieved through FPL's 497 substations.

The existing FPL system, including generating plants, major transmission stations, and transmission lines, is shown on Figure I.A.2. In addition, Figure I.A.3. shows FPL's interconnection ties with other utilities.

Capacity Resources (as of December 31, 2000)

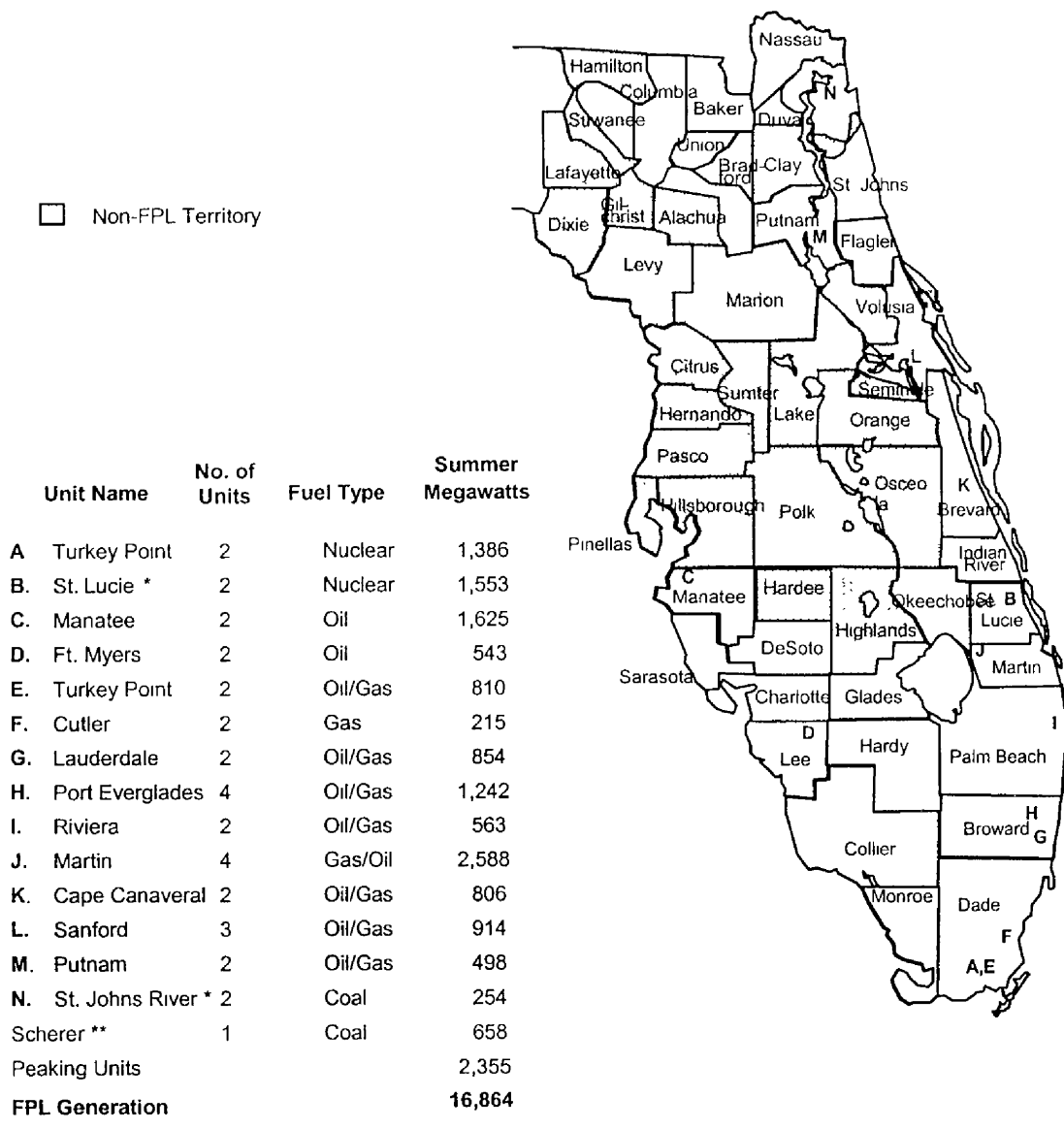

* Represents FPL's ownership share St. Lucie nuclear: 100% unit 1, 85% unit 2; St. Johns River: 20% of two units.

** The Scherer unit is located in Georgia and is not shown on this map.

Figure I.A.1

FPL Substation and Transmission System Configuration

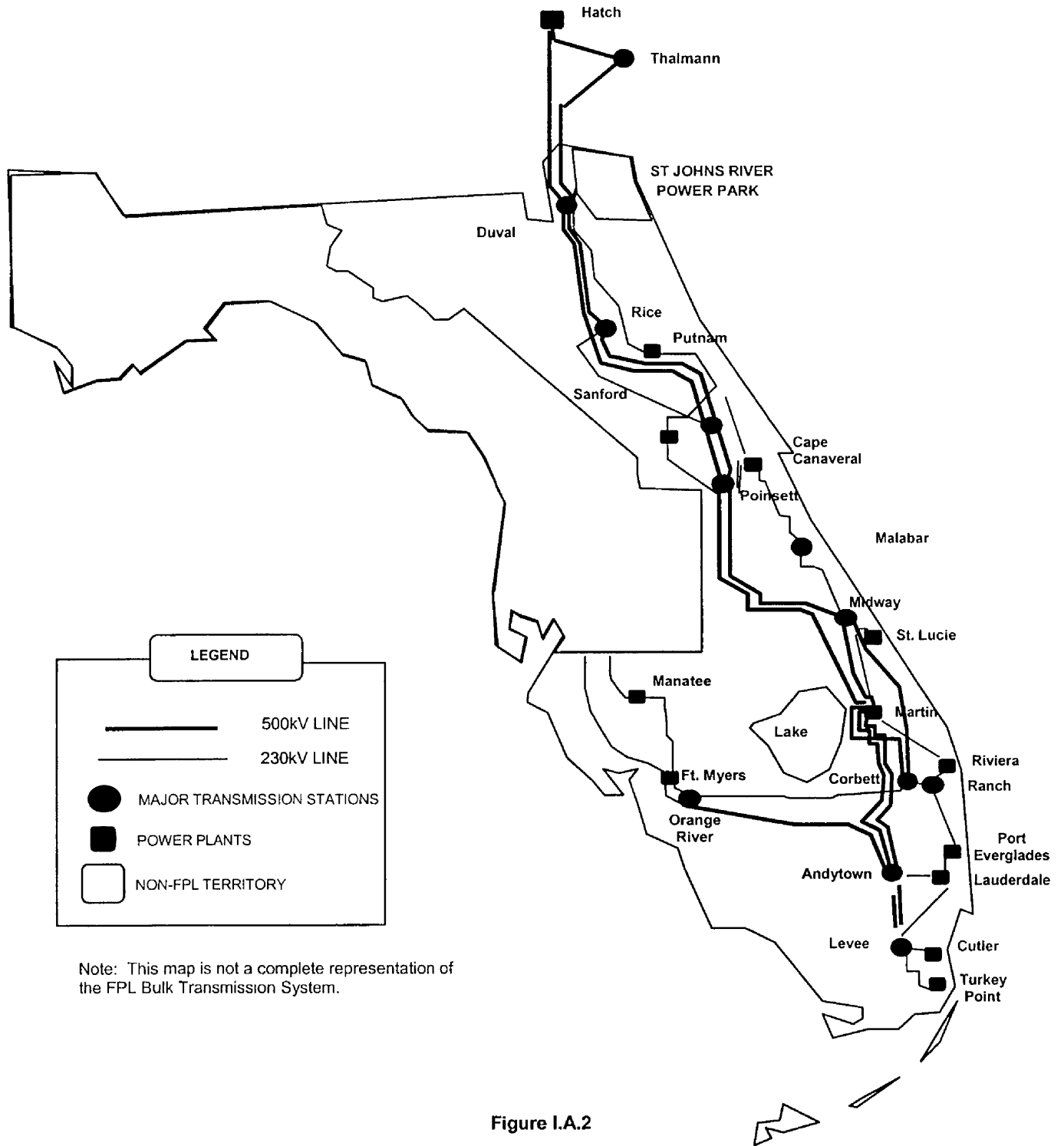

Figure I.A.2

FPL Interconnection Diagram

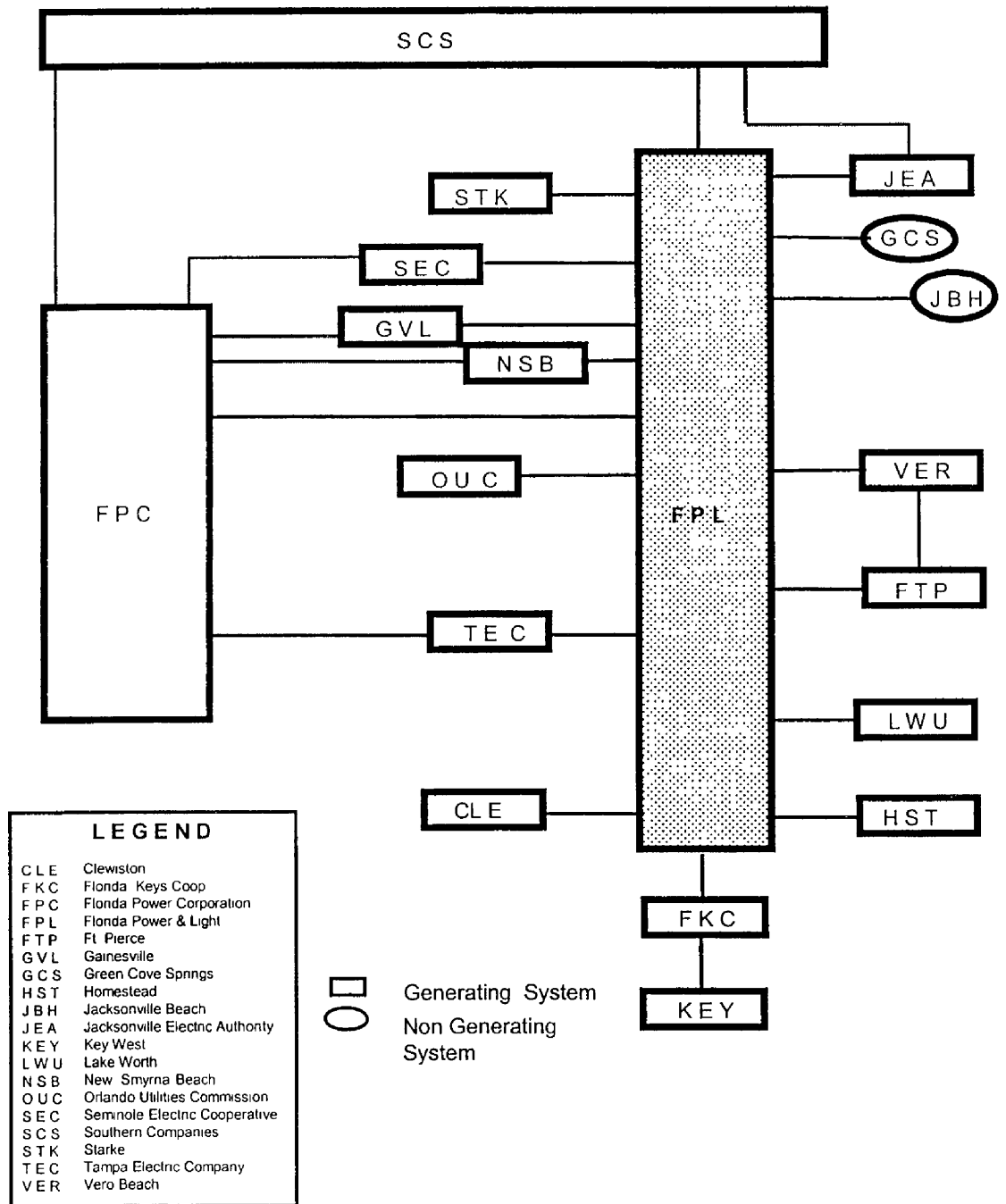

Figure I.A.3

I.B Non-Utility Generation

Non-utility generation is an important part of FPL's resource mix. FPL currently has contracts with eight cogeneration/small power production facilities to purchase firm capacity and energy. A listing of these facilities appears in Table I.B.1. In addition, FPL purchases as-available (non-firm) energy from several cogeneration facilities and small power production facilities as shown in Table I.B.2.

A cogeneration facility is one which simultaneously produces electrical and thermal energy, with the thermal energy (e.g., steam) being used for industrial, commercial, or cooling and heating purposes. A small power production facility is one which does not exceed 80 MW (unless it is exempted from this size limitation by the Solar, Wind, Waste, and Geothermal Power Production Incentives Act of 1990) and uses as its primary energy source (at least 50%) solar, wind, waste, geothermal, or other renewable resources.

Florida Power & Light Company
Firm Capacity and Energy Contracts with
Cogeneration/Small Power Production Facilities

<i>Project</i>	<i>County</i>	<i>Fuel</i>	<i>MW Capacity</i>	<i>In-Service Date</i>	<i>End Date</i>
Bio-Energy	Broward	Landfill Gas	10.0	5/1/98	1/1/05
Broward South	Broward	Solid Waste	50.6	4/1/91	8/1/09
			1.4	1/1/93	12/31/26
			1.5	1/1/95	12/31/26
			0.6	1/1/97	12/31/26
Broward North	Broward	Solid Waste	45.0	4/1/92	12/31/10
			7.0	1/1/93	12/31/26
			1.5	1/1/95	12/31/26
			2.5	1/1/97	12/31/26
Royster Mulberry	Polk	Waste Heat	8.0	4/1/92	3/31/02
			1.0	12/1/95	3/31/02
Cedar Bay Generating Co.	Duval	Coal (CFB)	250.0	1/25/94	12/31/24
Indiantown Cogen., LP	Martin	Coal (PC)	330.0	12/22/95	12/1/25
Palm Beach SWA	Palm Beach	Solid Waste	43.5	4/1/92	3/31/10
Florida Crushed Stone	Hernando	Coal (PC)	110.0	4/1/92	10/31/05
			11.0	1/1/94	10/31/05
			12.0	1/1/95	10/31/05

Table I.B.1

As-Available Energy Purchases From Non-Utility Generators in 2000				
Project	County	Fuel	In-Service Date	Energy (MWH) Delivered to FPL in 2000
US Sugar-Bryant	Palm Beach	Bagasse	2/80	5,101
Tropicana	Manatee	Natural Gas	2/90	10,886
Okeelanta	Palm Beach	Bagasse/Wood	11/95	296,140
Tomoka Farms	Volusia	Landfill Gas	7/98	19,868
Georgia Pacific	Putnam	Paper By- Product	2/94	8,925

Table I.B.2

I.C. Demand Side Management (DSM)

FPL's DSM activities continue what has been FPL's practice since 1978 of encouraging cost-effective conservation and load management. FPL's DSM efforts through 2000 have resulted in a cumulative Summer peak reduction of approximately 2,680 MW at the meter and an estimated cumulative annual energy saving of 4,830 GWH at the meter.

FPL's current DSM Plan was approved by the Florida Public Service Commission in late 1999 and reflects FPL's new DSM Goals for the 2000 – 2009 time frame. FPL's 2000 resource plan, and the schedule for new generation additions presented in this document, are based on these approved DSM levels.

I.D. Purchased Power

Purchased power remains an important part of FPL's resource mix. FPL has a unit power sales (UPS) contract to purchase up to 931 MW, with a minimum of 380 MW, of coal-fired generation from the Southern Company. In addition, FPL has contracts with the Jacksonville Electric Authority (JEA) for the purchase of 382 MW (Summer) and 388 MW (Winter) of coal-fired generation from the St. John's River Power Park (SJRPP) Unit Nos. 1 and 2 (FPL also has an ownership interest in these units; that ownership amount is reflected in FPL's installed capacity shown on Schedule 1).

Finally, FPL is projecting new firm capacity purchases for the mid - 2001 to mid - 2005 time period. These firm capacity purchases are projected to come from a variety of suppliers. Table I.D.1 presents the Summer and Winter MW resulting from these purchased power contracts through the year 2010.

<i>FPL's Purchased Power MW ⁽¹⁾</i>								
<i>Year</i>	<i>UPS</i>		<i>SJRPP</i>		<i>New Firm Capacity Purchases ⁽³⁾</i>		<i>Total</i>	
	<i>Winter</i>	<i>Summer</i>	<i>Winter</i>	<i>Summer</i>	<i>Winter</i>	<i>Summer</i>	<i>Winter</i>	<i>Summer</i>
2000 ⁽²⁾	931	931	388	388	0	0	1319	1319
2001	931	931	388	382	0	196	1319	1509
2002	931	931	388	382	50	975	1369	2288
2003	931	931	388	382	1075	975	2394	2288
2004	931	931	388	382	1075	975	2394	2288
2005	931	931	388	382	1025	0	2344	1313
2006	931	931	388	382	0	0	1319	1313
2007	931	931	388	382	0	0	1319	1313
2008	931	931	388	382	0	0	1319	1313
2009	931	931	388	382	0	0	1319	1313
2010	931	0	388	382	0	0	1319	382

Note:

(1) Total reflects total resource entitlements resulting from existing agreements between FPL, Southern Companies, JEA, and from new firm purchase agreements

(2) Values for 2000 are actual

(3) A discussion of these new firm capacity purchases can also be found in Section III.A.

Table I.D.1

Schedule 1

**Existing Generating Facilities
As of December 31, 2000**

(1)	(2)	(3)	(4)	(5)	(6)	(7)	(8)	(9)	(10)	(11)	(12)	(13)	(14)
Plant Name	Unit No.	Location	Unit Type	Fuel		Transport		Fuel Days Use	Commercial In-Service Month/Year	Expected Retirement Month/Year	Gen Max Nameplate KW	Net Capability 1/	
				Pri.	Alt.	Pri.	Alt.					Summer MW	Winter MW
Turkey Point		Dade County 27/57S/40E									2,338,100	2,208	2,260
	1		ST	FO6	NG	WA	PL	Unknown	Apr-67	Unknown	402,050	410	411
	2		ST	FO6	NG	WA	PL	Unknown	Apr-68	Unknown	402,050	400	403
	3		NP	UR	No	TK	No	Unknown	Nov-72	Unknown	760,000	693	717
	4		NP	UR	No	TK	No	Unknown	Jun-73	Unknown	760,000	693	717
	1-5		IC	FO2	No	TK	No	Unknown	Dec-67	Unknown	14,000	12	12
Cutler		Dade County 27/55S/40E									236,500	215	217
	5		ST	NG	No	PL	No	Unknown	Nov-54	Unknown	74,500	71	72
	6		ST	NG	No	PL	No	Unknown	Jul-55	Unknown	162,000	144	145
Lauderdale		Broward County 30/50S/42E									1,863,972	1,694	1,952
	4		CC	NG	FO2	PL	PL	Unknown	Oct-57	Unknown	521,250	427	467
	5		CC	NG	FO2	PL	PL	Unknown	Apr-58	Unknown	521,250	427	467
	1-12		GT	NG	FO2	PL	PL	Unknown	Aug-70	Unknown	410,736	420	509
	13-24		GT	NG	FO2	PL	PL	Unknown	Aug-72	Unknown	410,736	420	509
Port Everglades		City of Hollywood 23/50S/42E									1,665,086	1,662	1,757
	1		ST	FO6	NG	WA	PL	Unknown	Jun-60	Unknown	225,250	221	222
	2		ST	FO6	NG	WA	PL	Unknown	Apr-61	Unknown	225,000	221	222
	3		ST	FO6	NG	WA	PL	Unknown	Jul-64	Unknown	402,050	390	392
	4		ST	FO6	NG	WA	PL	Unknown	Apr-65	Unknown	402,050	410	412
	1-12		GT	NG	FO2	PL	PL	Unknown	Aug-71	Unknown	410,736	420	509

1/ These ratings are peak capability

Schedule 1

**Existing Generating Facilities
As of December 31, 2000**

(1)	(2)	(3)	(4)	(5)	(6)	(7)	(8)	(9)	(10)	(11)	(12)	(13)	(14)
Plant Name	Unit No.	Location	Unit Type	Fuel		Transport		Fuel Days Use	Commercial In-Service Month/Year	Expected Retirement Month/Year	Gen Max Nameplate KW	Net Capability 1/	
				Pri.	Alt.	Pri.	Alt.					Summer MW	Winter MW
Riviera		City of Riviera Beach 33/42S/43E									<u>620,840</u>	<u>563</u>	<u>565</u>
	3		ST	FO6	NG	WA	PL	Unknown	Jun-62	Unknown	310,420	283	283
	4		ST	FO6	NG	WA	PL	Unknown	Mar-63	Unknown	310,420	280	282
Martin		Martin County 29/29S/38E									<u>2,950,000</u>	<u>2,588</u>	<u>2,674</u>
	1		ST	NG	FO6	PL	PL	Unknown	Dec-80	Unknown	863,000	824	843
	2		ST	NG	FO6	PL	PL	Unknown	Jun-81	Unknown	863,000	816	831
	3		CC	NG	FO2	PL	PL	Unknown	Feb-94	Unknown	612,000	474	500
	4		CC	NG	FO2	PL	PL	Unknown	Apr-94	Unknown	612,000	474	500
St Lucie		St Lucie County 16/36S/41E									<u>1,553,000</u>	<u>1,553</u>	<u>1,579</u>
	1		NP	UR	No	TK	No	Unknown	May-76	Unknown	839,000	839	853
	2	2/	NP	UR	No	TK	No	Unknown	Jun-83	Unknown	714,000	714	726
Cape Canaveral		Brevard County 19/24S/36F									<u>804,100</u>	<u>806</u>	<u>812</u>
	1		ST	FO6	NG	WA	PL	Unknown	Apr-65	Unknown	402,050	403	406
	2		ST	FO6	NG	WA	PL	Unknown	May-69	Unknown	402,050	403	406
Sanford		Volusia County 16/19S/30E									<u>1,022,450</u>	<u>914</u>	<u>919</u>
	3		ST	FO6	NG	WA	PL	Unknown	May-59	Unknown	150,250	142	144
	4		ST	FO6	NG	WA	PL	Unknown	Jul-72	Unknown	436,100	381	384
	5		ST	FO6	No	WA	No	Unknown	Jul-73	Unknown	436,100	391	391

1/ These ratings are peak capability

2/ Total capability is 839/853 MW Capabilities shown represent the company's share of the unit and exclude the Orlando Utilities Commission (OUC) and Florida Municipal Power Agency (FMPA) combined portion of 14.89551%

Schedule 1

**Existing Generating Facilities
As of December 31, 2000**

(1)	(2)	(3)	(4)	(5)	(6)	(7)	(8)	(9)	(10)	(11)	(12)	(13)	(14)
Plant Name	Unit No	Location	Unit Type	Fuel Pri	Fuel Alt	Fuel Transport		Fuel Days Use	Commercial In-Service Month/Year	Expected Retirement Month/Year	Gen.Max Nameplate KW	Net Capability 1/	
						Pri	Alt					Summer MW	Winter MW
Putnam		Putnam County 16/10S/27E									580,000	498	594
	1		CC	NG	FO2	PL	WA	Unknown	Apr-78	Unknown	290,000	249	297
	2		CC	NG	FO2	PL	WA	Unknown	Aug-77	Unknown	290,000	249	297
Fort Myers		Lee County 35/43S/25E									1,302,250	1,626	1,856
	1		ST	FO6	No	WA	No	Unknown	Nov-58	Unknown	156,250	141	142
	2		ST	FO6	No	WA	No	Unknown	Jul-69	Unknown	402,000	402	402
	1-12		GT	FO2	No	WA	No	Unknown	May-74	Unknown	744,000	636	769
	Repowering CT's (3)		GT	NG	FO2	PL	PL	Unknown	Dec-00	Unknown	543,000	447	543
Manatee		Manatee County 18/33S/20E									1,726,600	1,625	1,639
	1		ST	FO6	No	WA	No	Unknown	Oct-76	Unknown	863,300	815	822
	2		ST	FO6	No	WA	No	Unknown	Dec-77	Unknown	863,300	810	817
St Johns River Power Park 2/		Duval County 12/15/28E									250,000	254	260
	1		BIT	BIT	No	RR	No	Unknown	Mar-87	Unknown	125,000	127	130
	2		BIT	BIT	No	RR	No	Unknown	May-88	Unknown	125,000	127	130
Scherer 3/		Monroe, GA									891,000	658	666
	4		BIT	BIT	No	RR	No	Unknown	Jul-89	Unknown	891,000	658	666
Total System as of December 31, 2000 =												16,864	17,750

1/ These ratings are peak capability.

2/ The net capability ratings represent Florida Power & Light Company's share of St. Johns River Park Unit No 1 and No. 2, excluding Jacksonville Electric Authority (JEA) share of 80% , SJRPP receives coal by water (WA) in addition to rail

3/ These ratings represent Florida Power & Light Company's share of Scherer Unit No. 4, adjusted for transmission losses

(This page is left intentionally blank.)

CHAPTER II

Forecast of Electric Power Demand

(This page is left intentionally blank)

II. Forecast of Electric Power Demand

Long-term (20-year) forecasts of sales, net energy for load (NEL), and peak loads are developed on an annual basis for resource planning work at FPL. These forecasts are a key input to the models used to develop the Integrated Resource Plan. The following pages describe how forecasts are developed for each component of the long-term forecast: sales, NEL, and peak loads.

The primary drivers to develop these forecasts are demographic trends, weather and economic conditions, and prices of electricity and other energy sources. In addition to these drivers, the resulting forecasts are an integration of economic evaluations, inputs of local economic development boards, weather assessments from NOAA, and inputs from FPL's own customer service planning areas. In the area of demographics, population trends by county, plus housing characteristics such as housing starts, housing size, and vintage of homes, are assessed.

Forecasts for electric usage in the residential and commercial classes include end-use information such as appliance saturation studies, efficiencies, and intensity of energy use. In addition to these inputs, residential forecasts also make use of household characteristics such as ages of members in household, number of members in households, and income distributions.

Several economic forecasting services are contracted to obtain their economic outlook for FPL's service territory. These include Wharton Economic Forecasting Associates (WEFA), Data Resources Incorporated (DRI), and the Bureau of Economic and Business Research (BEBR) of the University of Florida. In addition, FPL actively participates with local development councils and universities to obtain their assessments of the local economy, specifically in the area of expansion of new businesses and retention of the current business base. These inputs are quantified and qualified using statistical models in terms of their impact on the future demand for electricity.

In recent years, the rise of the Tele-communications industry and its potential impact on electric demand has added a new dimension to the forecasting process. Since the needs of the customers in this industry are very project - specific, the customer representatives servicing this class of customers provide insight as to the magnitude and timing of each future project and this information is used in developing the forecast. For example, FPL's 2000 forecast includes an estimate that in 3 years the new load attributed to Tele-

communications facilities could reach as much as 570 MW. This additional load in its entirety was treated as a line item adjustment and was added to FPL's 2000 energy and peak forecasts.

II.A. Long-Term Sales Forecasts

Long-term forecasts of electricity sales were developed for each revenue class for the forecasting period of 2000 – 2019. The results of these sales forecasts are presented in Schedules 2.1 – 2.3 which appear at the end of this chapter. Econometric models are developed for each revenue class using the statistical tool Metrix ND. The methodologies used to develop sales forecasts for each jurisdictional revenue class are outlined below.

1. Residential Sales

Residential energy sales are forecast by multiplying the residential use per customer forecast by the residential customer forecast. Residential electric usage per customer is estimated by using a regression model which contains the real residential price of electricity, Florida per capita income, and Cooling and Heating Degree Days as explanatory variables. The price of electricity plays a role in explaining electric usage since electricity, like all other goods and services, will be purchased in greater or lesser quantities depending upon its price. The Cooling & Heating Degree Days are used to capture the changes in the electric usage of weather-sensitive appliances such as air conditioners and electric heaters. A composite temperature is derived using hourly temperatures across FPL's service territory (Miami, Ft. Myers, Daytona Beach, and West Palm Beach are the locations from which temperatures are obtained) weighted by regional energy sales. This composite temperature is used to derive Cooling and Heating Degree Days which are based on starting point temperatures of 72°F and 66°F, respectively. The Cooling Degree Days variable is multiplied by the level of air conditioning saturations and the Heating Degree Days variable is multiplied by the level of electric heating saturations. To capture economic conditions the model includes Florida per capita income. The degree of economic prosperity can, and does, affect residential electricity sales.

2. Commercial Sales

The commercial sales forecast is also developed using a regression model. Commercial sales are a function of the following variables: Florida non-agricultural employment, commercial real price of electricity, and Cooling Degree Days. Florida non-agricultural

employment is used to capture the economic activity in FPL's service territory. The price of electricity is also included as an explanatory variable in the model because it has an impact on customer usage. Cooling Degree Days are used to capture weather-sensitive load in the commercial sector.

3. Industrial Sales

Industrial sales were forecasted through a linear multiple regression model using Florida manufacturing employment and the price of electricity as explanatory variables. Energy sales in this revenue class are primarily due to manufacturers; therefore, employment in this sector is a key variable in capturing the economic activity. The price of electricity is also included as an explanatory variable in the model because it has an impact on customer usage.

4. Other Public Authority Sales

The sales for this class are developed using an econometric model. Florida manufacturing employment and the other public authority sales of the previous year are used as explanatory variables.

5. Street & Highway Sales and Railroad & Railways Sales

The forecast of Street & Highway sales was developed using a regression model with FPL's total customers and the street and highway sales of the previous period serving as inputs.

The forecasts for Railroads & Railways are held constant since there are no plans for expansion of this economic sector in FPL's service territory.

6. Resales Sales

Resale (Wholesale) customers are composed of municipalities and/or electric cooperatives. These customers differ from jurisdictional customers in that they are not the ultimate users of the electricity they buy. Instead, they resell this electricity to their own customers.

Contract Rate

Currently there are four customers in this class: the Florida Keys Electric Cooperative (Florida Keys), City Electric System of the Utility Board of the City of Key West, Florida (City of Key West), Metro-Dade County, and FMPA. Sales to the Florida Keys are forecasted using a regression model. Forecasted sales to the City of Key West are based on assumptions regarding their contract demand and expected load factor. Metro-Dade County sells 60 MW to Florida Power Corporation. Line losses are billed to Metro-Dade under a wholesale contract. The forecast is calculated based on assumptions about the magnitude of line losses, the sales monthly capacity factor, and the number of hours in a particular month. FMPA has contracted for delivery of 75 MW for the period of June 2002 through October 2007.

Total Sales

Sales forecasts by revenue class are summed to produce a total sales forecast. After an estimate of annual total sales is obtained, an expansion factor is applied to generate a forecast of annual Net Energy for Load (NEL).

II.B. Net Energy for Load

An annual econometric model is developed to produce a Net Energy for Load (NEL) forecast. The key inputs to the model are: the price of electricity, Heating & Cooling Degree Days, and Florida Non-Agricultural Employment. Once an annual NEL forecast is obtained using the above-mentioned model, the results are then compared for reasonability to the NEL forecast generated using the total sales forecast. The sales by class are then adjusted to match the NEL from the annual NEL model.

The monthly NEL forecast is also generated for the entire long-term forecasting period of 2000 – 2019. Historical data is used to develop month-to-annual ratios. The ratios are then used to produce the monthly NEL forecast.

The forecasted NEL values for 2001 – 2010 are presented in Schedule 3.3 which appears at the end of this chapter.

II.C. System Peak Forecasts

In recent years, the absolute growth in FPL system load has been associated with a larger customer base, varying weather conditions, continued economic growth, changing patterns of customer behavior (including an increasing stock of electricity-consuming appliances), and more efficient heating and cooling appliances. The Peak Forecast models were developed to capture these behavioral relationships.

The forecasting methodology of Summer, Winter, and monthly system peaks is discussed below. The forecasted values for Summer and Winter peak loads for the years 2001 - 2010 are presented in Schedules 3.1 and 3.2, as well as in Schedules 7.1 and 7.2.

System Summer Peak

The Summer peak forecast is developed using an econometric model. Key variables used in the model include: the total number of FPL Summer customers, the price of electricity, a ratio of Gross Domestic Product (GDP) and Florida Non-Agricultural employment, a dummy variable, and a weather variable. The dummy variable is included to capture the structural change in the economy after the oil crisis in 1975. The weather variable is the product of saturation of air conditioning equipment and maximum Summer temperature.

System Winter Peak

Like the system Summer peak model, this model is also an econometric model. The Winter peak model is a per customer model which consists of three weather-related variables: the minimum temperature on the peak day, a weather term which is a product of heating saturation and minimum Winter day temperature, and Heating Degree Hours for the prior day as well as for the morning of the Winter peak day. In addition, the model also has an economic term which is a ratio of GDP and Florida non-agricultural employment, a dummy variable used to capture the effects of larger homes, and another dummy variable designed to provide additional emphasis for the more recent weather data.

Monthly Peak Forecasts

Monthly peaks for the 2000 - 2019 period are forecasted to provide information for the scheduling of maintenance for power plants and fuel budgeting. The forecasting process is basically the same as for the monthly NEL forecast:

- a. Develop the historical seasonal factor for each month by using ratios of historical monthly peaks to seasonal peak (Summer = April-October, Winter = November-March).

- b. Apply the monthly ratios to their respective seasonal peak forecast to derive the peak forecast by month. This process assumes that the seasonal factors remain unchanged over the forecasting period.

II.D The Hourly Load Forecast

Forecasted values for system hourly load for the period 2000 - 2019 are produced using a System Load Forecasting "shaper" program. This model uses sixteen years of historical FPL hourly system load data to develop load shapes for weekdays, weekend days, and holidays. These daily load shapes are ranked and used with forecasted monthly peaks, NEL, and calendars in developing an hourly forecast. The model allows calibration of hourly values where the peak is maintained or where both the peak and minimum load-to-peak ratio is maintained.

**Schedule 2.1
History and Forecast of Energy Consumption
And Number of Customers by Customer Class**

(1)	(2)	(3)	(4)	(5)	(6)	(7)	(8)	(9)
Rural & Residential					Commercial			
Year	Population**	Members per Household	GWH	Average*** No. of Customers	Average KWH Consumption Per Customer	GWH	Average*** No of Customers	Average KWH Consumption Per Customer
1991	6,211,996	2.17	34,617	2,863,198	12,090	27,232	343,834	79,200
1992	6,314,005	2.17	34,198	2,911,807	11,745	26,991	350,269	77,058
1993	6,380,715	2.14	36,360	2,975,479	12,220	28,508	358,679	79,481
1994	6,516,879	2.15	38,716	3,037,629	12,745	29,946	366,409	81,729
1995	6,639,165	2.14	40,556	3,097,192	13,094	30,719	374,005	82,135
1996	6,754,084	2.14	41,302	3,152,625	13,101	31,211	380,860	81,949
1997	6,884,909	2.15	41,849	3,209,298	13,040	32,942	388,906	84,703
1998	7,014,152	2.15	45,482	3,266,011	13,926	34,618	396,749	87,255
1999	7,133,361	2.14	44,187	3,332,422	13,260	35,524	404,942	87,725
2000	7,282,933	2.13	46,320	3,414,002	13,568	37,001	415,295	89,096
2001 *	7,406,700	2.13	46,949	3,471,810	13,523	39,840	426,053	93,508
2002 *	7,527,519	2.13	48,497	3,538,346	13,706	41,421	437,810	94,608
2003 *	7,645,392	2.12	49,807	3,603,435	13,822	43,654	448,835	97,262
2004 *	7,760,318	2.12	50,558	3,666,716	13,788	44,537	459,199	96,989
2005 *	7,872,296	2.11	51,302	3,727,940	13,762	45,404	469,038	96,803
2006 *	7,983,660	2.11	52,026	3,786,871	13,738	46,220	478,234	96,647
2007 *	8,095,024	2.11	52,730	3,843,274	13,720	47,004	487,101	96,498
2008 *	8,208,083	2.11	53,425	3,897,570	13,707	47,799	495,697	96,427
2009 *	8,322,839	2.11	54,141	3,950,803	13,704	48,619	504,107	96,446
2010 *	8,437,594	2.11	54,952	4,003,154	13,727	49,516	512,269	96,660

* Forecasted values for these years reflect the Most Likely economic scenario

** Population represents only the area served by FPL

*** Average No. of Customers is the annual average of the twelve month values

Schedule 2.2
History and Forecast of Energy Consumption
And Number of Customers by Customer Class

(1)	(10)	(11)	(12)	(13)	(14)	(15)	(16)
Year	<u>GWH</u>	<u>Industrial</u> Average** No of Customers	<u>Average KWH</u> Consumption Per Customer	<u>Railroads</u> & <u>Railways</u> GWH	<u>Street &</u> <u>Highway</u> <u>Lighting</u> GWH	<u>Other</u> <u>Sales to</u> <u>Public</u> <u>Authorities</u> GWH	<u>Total***</u> <u>Sales to</u> <u>Ultimate</u> <u>Consumers</u> GWH
1991	4,090	15,348	266,493	81	345	733	67,098
1992	4,054	14,788	274,135	77	353	721	66,393
1993	3,889	14,866	261,602	79	330	665	69,830
1994	3,845	15,588	246,658	85	353	664	73,608
1995	3,883	15,140	256,481	84	358	648	76,248
1996	3,792	14,783	256,515	83	368	577	77,334
1997	3,894	14,761	263,830	85	383	702	79,855
1998	3,951	15,126	261,233	81	373	625	85,131
1999	3,948	16,040	246,112	79	473	465	84,676
2000	3,768	16,410	229,592	81	408	381	87,959
2001	* 3,953	15,631	252,888	80	406	500	91,728
2002	* 3,987	15,637	255,005	81	404	523	94,913
2003	* 4,016	15,665	256,344	82	404	540	98,503
2004	* 4,047	15,743	257,072	83	405	553	100,183
2005	* 4,084	15,836	257,914	84	408	563	101,845
2006	* 4,111	15,901	258,540	83	411	571	103,421
2007	* 4,135	15,966	258,995	83	414	577	104,944
2008	* 4,158	16,029	259,397	84	419	582	106,466
2009	* 4,175	16,075	259,699	84	423	586	108,028
2010	* 4,199	16,280	257,919	83	428	589	109,767

* Forecasted values for these years reflect the Most Likely economic scenario

** Average No.of Customers is the annual average of the twelve month values

*** Total Sales GWH = Col 4 + Col 7 + Col 10 + Col 13 + Col 14 + Col 15

**Schedule 2.3
History and Forecast of Energy Consumption
And Number of Customers by Customer Class**

(1)	(17)	(18)	(19)	(20)	(21)
Year	Sales for Resale GWH	Utility Use & Losses GWH	Net*** Energy For Load GWH	Average ** No of Other Customers	Total Average**** Number of Customers
1991	716	5,346	73,160	4,076	3,226,455
1992	702	6,002	73,097	4,374	3,281,238
1993	958	4,988	75,776	3,086	3,352,110
1994	1,400	5,367	80,376	2,560	3,422,187
1995	1,437	6,276	83,961	2,460	3,488,796
1996	1,353	5,984	84,671	2,480	3,550,748
1997	1,228	5,770	86,853	2,520	3,615,485
1998	1,326	6,205	92,662	2,584	3,680,470
1999	953	5,829	91,458	2,605	3,756,009
2000	970	7,059	95,989	2,694	3,848,401
2001	• 992	6,837	99,557	2,604	3,916,098
2002	• 1,215	7,087	103,215	2,601	3,994,394
2003	• 1,434	7,369	107,306	2,598	4,070,533
2004	• 1,455	7,493	109,131	2,595	4,144,253
2005	• 1,474	7,617	110,936	2,592	4,215,407
2006	• 1,474	7,733	112,628	2,589	4,283,595
2007	• 1,407	7,913	114,264	2,586	4,348,927
2008	• 1,073	8,360	115,899	2,583	4,411,879
2009	• 1,073	8,476	117,577	2,580	4,473,566
2010	• 1,073	8,607	119,447	2,577	4,534,280

- Forecasted values for these years reflect the Most Likely economic scenario
- ** Average Number of Customers is the annual average of the twelve month values
- *** Net Energy for Load GWH = Col. 16 + Col 17 + Col 18
- **** Average No of Customers Total = Col 5 + Col 8 + Col 11 + Col. 20

**Schedule 3.1
History and Forecast of Summer Peak Demand: Base Case**

(1)	(2)	(3)	(4)	(5)	(6)	(7)	(8)	(9)	(10)
Year	Total	Wholesale	Retail	Interruptible	Res Load Management	Residential Conservation	C/I Load Management	C/I Conservation	Net Firm Demand
1991	14,123	281	13,842	0	160	129	177	38	13,786
1992	14,661	223	14,438	0	234	151	248	51	14,179
1993	15,266	397	14,869	0	311	182	320	79	14,635
1994	15,179	409	14,770	0	392	220	354	125	14,433
1995	16,172	435	15,737	0	466	259	391	193	15,315
1996	16,064	364	15,700	0	531	339	414	296	15,119
1997	16,613	380	16,233	0	615	440	432	341	15,566
1998	17,897	426	17,471	0	656	480	441	359	16,800
1999	17,615	169	17,446	0	722	565	450	397	16,443
2000	17,808	161	17,647	0	767	626	456	432	16,585
2001	18,150	148	18,003	0	784	87	480	55	16,744
2002	18,801	225	18,576	0	793	128	490	74	17,316
2003	19,507	227	19,280	0	799	169	499	93	17,947
2004	19,964	229	19,735	0	805	211	510	113	18,325
2005	20,433	231	20,201	0	811	254	519	134	18,715
2006	20,918	231	20,687	0	817	298	527	154	19,122
2007	21,392	231	21,160	0	822	343	535	174	19,518
2008	21,788	156	21,632	0	827	389	543	193	19,836
2009	22,220	156	22,063	0	831	436	549	212	20,192
2010	22,722	156	22,565	0	832	451	550	219	20,670

Historical Values (1991 - 2000):

Cols (2) - (4) are actual values for historical summer peaks. As such, they incorporate the effects of conservation (Cols. (7&9)), and MAY incorporate the effects of load control IF load control was operated on these peak days. Therefore, Col. (2) represents the actual Net Firm Demand. Cols (5) - (9) represent actual DSM capabilities starting from January 1988.

Note that the values for FPL's former Interruptible Rate are incorporated into Col (8), which also includes CILC and GS-LC.

Col (10) represents a HYPOTHETICAL "Net Firm Demand" if the load control values had definitely been exercised on the peak. Col (10) is derived by the formula Col (10) = Col. (2) - Col.(6) - Col (8).

Projected Values (2001 - 2010):

Cols (2) - (4) represent FPL's forecasted peak w/o incremental conservation or cumulative load control. The effects of conservation implemented prior to 2000 are incorporated into the forecast.

Cols (5) - (9) represent all incremental conservation and cumulative load control. These values are projected August values and are based on projections with a 1/2000 starting point.

Col (10) represents a "Net Firm Demand" which accounts for all of the incremental conservation and assumes all of the load control is implemented on the peak. Col (10) is derived by using the formula Col (10) = Col (2) - Col (5) - Col (6) - Col (7) - Col (8) - Col (9).

**Schedule 3.2
History and Forecast of Winter Peak Demand:Base Case**

(1)	(2)	(3)	(4)	(5)	(6)	(7)	(8)	(9)	(10)
Year	Total	Firm Wholesale	Retail	Interruptible	Res Load Management	Residential Conservation	C/I Load Management	C/I Conservation	Net Firm Demand
1991/92	13,319	105	13,214	0	174	170	193	38	12,952
1992/93	12,964	102	12,862	0	242	195	275	48	12,447
1993/94	12,594	278	12,316	0	317	231	342	67	11,935
1994/95	16,563	635	15,928	0	393	265	360	93	15,810
1995/96	18,096	698	17,398	0	459	310	406	143	17,231
1996/97	16,490	626	15,864	0	731	368	418	154	15,341
1997/98	13,060	239	12,821	0	823	403	429	168	11,807
1998/99	16,802	149	16,653	0	1,218	438	417	182	15,167
1999/00	17,057	142	16,915	0	1,296	469	441	193	15,320
2000/01	18,219	150	18,069	0	972	493	448	201	16,799
2001/02	19,333	130	19,203	0	1,403	81	459	26	17,364
2002/03	20,122	206	19,915	0	1,414	107	465	33	18,103
2003/04	20,555	208	20,347	0	1,425	132	471	41	18,486
2004/05	20,986	210	20,776	0	1,436	156	477	50	18,867
2005/06	21,413	210	21,203	0	1,446	181	483	59	19,244
2006/07	21,841	210	21,631	0	1,455	205	487	68	19,626
2007/08	22,186	135	22,051	0	1,464	228	492	77	19,925
2008/09	22,586	135	22,451	0	1,473	251	497	86	20,279
2009/10	22,978	135	22,843	0	1,480	272	500	93	20,633

Historical Values (1991/92 - 2000/01):

Cols. (2) - (4) are actual values for historical winter peaks. As such, they incorporate the effects of conservation (Cols. (7&9)), and MAY incorporate the effects of load control IF load control was operated on these peak days. Therefore, Col. (2) represents the actual Net Firm Demand. Cols. (5) - (9) represent actual DSM capabilities starting from January 1988.

Note that the values for FPL's former Interruptible Rate are incorporated into Col. (8), which also includes CILC and GS - LC. Col. (10) represents a HYPOTHETICAL "Net Firm Demand" if the load control values had definitely been exercised on the peak. Col. (10) is derived by the formula: Col (10) = Col (2) - Col.(6) - Col.(8).

Projected Values (2001/02-2009/10):

Cols. (2) - (4) represent FPL's forecasted peak w/o incremental conservation or cumulative load control. The effects of conservation implemented prior to 1997 are incorporated into the forecast.

Cols. (5) - (9) represent all incremental conservation and cumulative load control. These values in are projected August values and are based on projections with a 1/2000 starting point.

Col. (10) represents a "Net Firm Demand" which accounts for all of the incremental conservation and assumes all of the load control is implemented on the peak. Col. (10) is derived by using the formula: Col (10) = Col (2) - Col.(5) - Col (6) - Col (7) - Col (8) - Col (9).

Col. (10) represents a "Net Firm Demand" which accounts for all of the incremental conservation and assumes all of the load control is implemented on the peak. Col. (10) is derived by using the formula: Col (10) = Col (2) - Col (5) - Col.(6) - Col (7) - Col (8) - Col (9).

Schedule 3.3
History and Forecast of Annual Net Energy for Load - GWH: Base Case

(1)	(2)	(3)	(4)	(5)	(6)	(7)	(8)	(9)
Year	Total	Residential Conservation	C/I Conservation	Retail	Wholesale	Utility Use & Losses	Net Energy For Load	Load Factor(%)
1991	73,743	397	186	73,027	716	5,346	73,160	59.1%
1992	73,778	460	221	73,076	702	6,002	73,097	56.9%
1993	76,632	553	303	75,674	958	4,988	75,776	56.7%
1994	81,493	661	456	80,093	1,400	5,367	80,376	60.4%
1995	85,415	777	677	83,978	1,437	6,276	83,961	59.3%
1996	86,708	971	1,039	85,355	1,353	5,984	84,698	60.2%
1997	89,240	1,213	1,174	88,012	1,228	5,770	86,853	59.7%
1998	95,316	1,374	1,279	93,990	1,326	6,205	92,663	63.0%
1999	94,361	1,542	1,362	93,408	953	5,829	91,458	63.5%
2000	99,094	1,674	1,431	98,123	970	7,059	95,989	66.1%
2001	99,557	56	15	98,565	992	6,837	99,486	67.8%
2002	103,215	152	46	102,000	1,215	7,087	103,017	67.9%
2003	107,306	250	77	105,872	1,434	7,369	106,979	68.0%
2004	109,131	349	110	107,676	1,455	7,493	108,672	67.7%
2005	110,936	450	145	109,462	1,474	7,617	110,341	67.3%
2006	112,628	554	180	111,155	1,474	7,733	111,894	66.8%
2007	114,264	659	213	112,857	1,407	7,913	113,392	66.3%
2008	115,899	765	245	114,826	1,073	8,360	114,889	66.1%
2009	117,577	874	276	116,504	1,073	8,476	116,427	65.8%
2010	119,447	919	291	118,374	1,073	8,607	118,237	65.3%

Historical Values (1991 - 2000):

Col (2) represents derived "Total Net Energy For Load w/o DSM" The values are calculated using the formula: Col.(2) = Col.(8) + Col (3) + Col (4)
 Cols. (3) & (4) are DSM values starting in January, 1988 through 1997 which contributed to the values in Cols (5) - (9)
 Cols (5) & (6) are a breakdown of Net Energy For Load in Col (2) into Retail and Wholesale
 Col. (9) is calculated using Col (8) from this page and Col (2), "Total", from Schedule 3.1

Projected Values (2001 - 2010):

Col. (2) represents Net Energy for Load w/o DSM values.
 Cols (3) - (4) are forecasted values of the reduction on sales from incremental conservation
 Cols (5) & (6) are a breakdown of Net Energy For Load in Col (2) , into Wholesale and Retail
 Col. (10) represents a "Net Firm Demand" which accounts for all of the incremental conservation and assumes all of the load control is implemented the values for Col. (8) above and the values for Col. (10) on Schedule 3.1

Schedule 4
Previous Year Actual and Two-Year Forecast of Retail Peak Demand and Net Energy for Load by Month

(1) Month	(2) 2000 ACTUAL		(4) 2001 * FORECAST		(6) 2002 * FORECAST	
	Total Peak Demand	NEL	Total Peak Demand	NEL	Total Peak Demand	NEL
	MW	GWH	MW	GWH	MW	GWH
JAN	17,057	6,947	18,840	7,427	19,333	7,700
FEB	12,755	6,377	16,776	6,783	17,259	7,033
MAR	13,411	7,099	14,529	7,282	14,948	7,550
APR	14,959	7,424	14,120	7,494	14,626	7,769
MAY	16,856	8,287	15,487	8,036	16,042	8,332
JUN	16,979	9,336	17,099	9,351	17,712	9,695
JUL	17,778	9,216	17,749	9,675	18,386	10,031
AUG	17,808	9,743	18,150	10,168	18,801	10,542
SEP	17,701	9,694	17,625	9,861	18,257	10,223
OCT	16,920	7,712	16,358	8,430	16,944	8,739
NOV	13,804	7,184	15,257	7,646	15,696	7,927
DEC	14,858	6,971	15,593	7,402	16,042	7,674
TOTALS		95,989		99,557		103,215

* Forecasted Peaks & NEL do not include the impacts of cumulative load management and incremental conservation

(This page is left intentionally blank.)

CHAPTER III

Projection of Incremental Resource Additions

(This page is left intentionally blank.)

III. Projection of Incremental Resource Additions

III.A FPL's Resource Planning:

FPL developed an integrated resource planning (IRP) process in the early 1990's and has since utilized the process to determine when new resources are needed, what the magnitude of the needed resources are, and what type of resources should be added. The timing and type of potential new power plants, the primary subjects of this document, are determined as part of the IRP process work. This section discusses how FPL applied this process in its 2000 planning work.

Four Fundamental Steps of FPL's Resource Planning:

There are 4 fundamental "steps" to FPL's resource planning. These steps can be described as follows:

Step 1: Determine the magnitude and timing of FPL's new resource needs,

Step 2: Identify which resource options and resource plans can meet the determined magnitude and timing of FPL's resource needs (i.e., identify competing options and resource plans);

Step 3: Determine the economics for the total utility system with each of the competing options and resource plans; and,

Step 4: Select a resource plan and commit, as needed, to near-term options.

Figure III.A.1 graphically outlines the 4 steps.

Overview of FPL's IRP Process

Fundamental IRP Steps

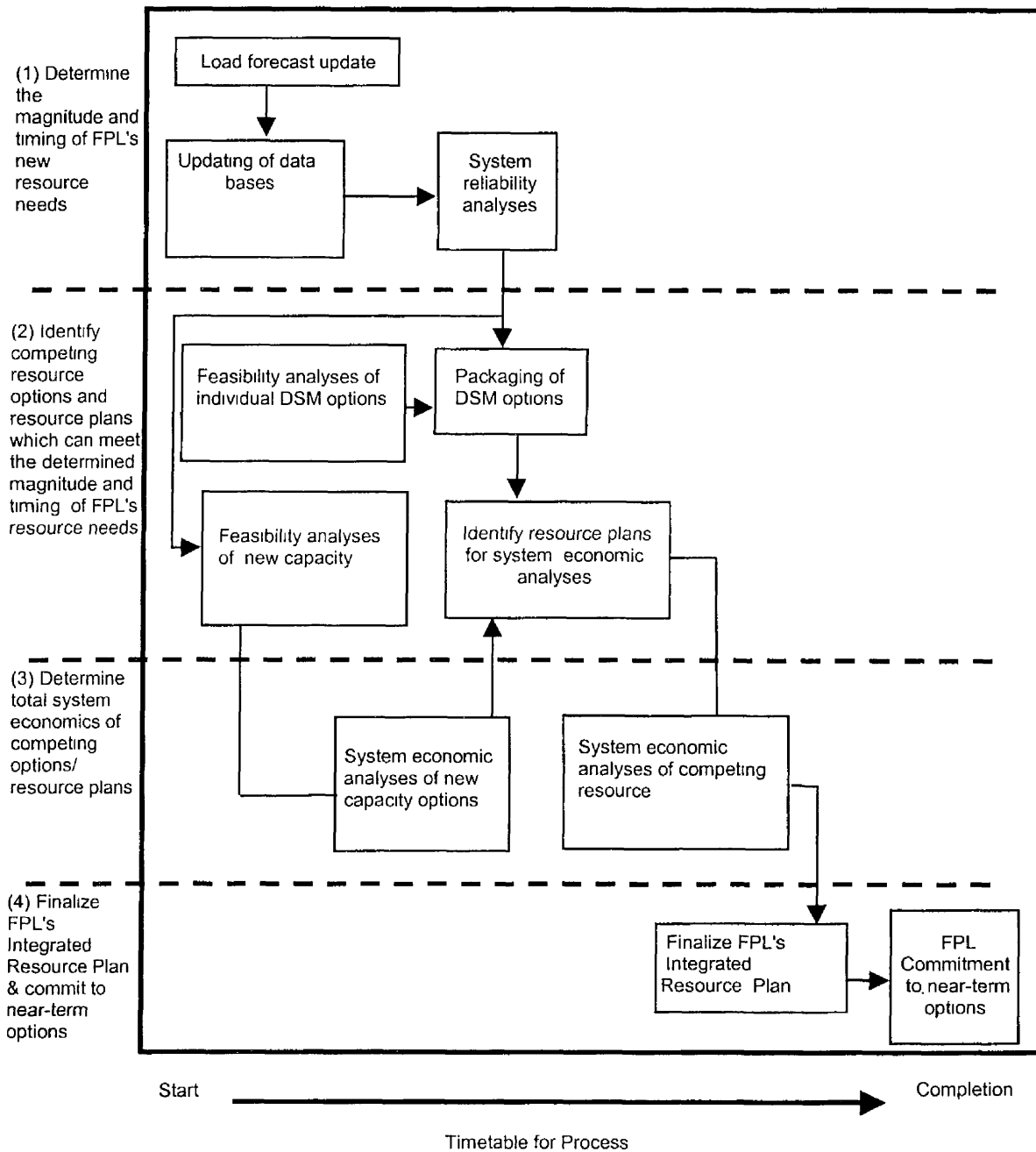

(Normal time period: approx. 6-7 months)

Figure III.A.1

Step 1: Determine the Magnitude and Timing of FPL's New Resource Needs:

The first of these four resource planning steps – determining the magnitude and timing of FPL's resource needs – is essentially a determination of how many megawatts (MW) of load reduction, new capacity, or a combination of both load reduction and new capacity options are needed. Also determined in this step is when the MW are needed to meet FPL's planning criteria. This step is often referred to as a reliability analysis for the utility system.

Step 1 starts with an updated load forecast. Several databases are also updated in this first fundamental step, not only with the new information regarding forecasted loads, but also with other information which is used in many of the fundamental steps in resource planning. Examples of this new information include: delivered fuel price projections, current financial and economic assumptions, and power plant capability and reliability assumptions. Four assumptions made by FPL during its 2000 IRP work involved near-term construction capacity additions, near-term firm capacity purchase additions, conversion of some of the near-term construction capacity additions from combustion turbine (CT) units to combined cycle (CC) units, and long-term DSM implementation.

The first of these assumptions included FPL's announced plans to add near-term capacity through various construction projects. These construction projects include the repowering of several existing units and the addition of several new CT's. FPL committed in 1998 to repower both existing steam units at its Fort Myers plant site and two of the three existing steam units at its Sanford plant site. These two repowering efforts will add significant capacity to FPL's system and will greatly increase the efficiency of the capacity at those two sites. The repowered Fort Myers capacity is scheduled to come in-service by the Summer, 2002. CT's, which are components of the repowering effort, began coming in-service at Fort Myers in late 2000 and through their initial operation in a stand-alone mode have already increased FPL's system capacity. A somewhat different schedule is planned for the two Sanford units which will be repowered. Both of these units will be repowered without the combustion turbine components coming in-service during the process. Sanford Unit No. 5 will come out-of-service in the Fall, 2001, and return fully repowered by Summer, 2002. Sanford Unit No. 4 will come out-of-service in the Spring, 2002, and return fully repowered at the end of 2002. As a result of this commitment, FPL assumed that these capacity additions resulting

from the Fort Myers and Sanford repowerings were a "given" in its 2000 resource planning work.

Another part of FPL's construction capacity addition assumption was its previously announced (in last year's Site Plan) decision to add four new CT's in the 2001 through 2003 time frame. The first two CT's are scheduled to be in-service at FPL's existing Martin site in 2001. The second pair of CT's is scheduled to be in-service in 2003 and will be placed at FPL's existing Fort Myers site. FPL's 2000 resource planning work assumed that these new CT construction capacity additions would also be a "given".

The second of the four assumptions made during the 2000 planning work was that the two CT's at Martin, and the two CT's at Fort Myers, would later be converted into one CC unit at each site. The resulting 2 - CT's – to – 1 - CC conversions at both Martin and Fort Myers are scheduled to be completed by mid-2005. These conversions were also assumed to be a "given" in FPL's 2000 resource planning work.

The third of these assumptions involved a decision which was made during FPL's 2000 resource planning work to secure an amount of capacity for the next few years through firm capacity, short-term purchases. These firm capacity purchases will be from a combination of utility and non-utility generators. These capacity purchases were not all finalized at the time of printing this document³, but negotiations were sufficiently far along so that FPL projects that the purchases will total approximately 975 MW (Summer) and 1,075 MW (Winter) and will begin in mid-2001 and run to mid-2005. This purchase amount is also assumed as a "given" in FPL's 2000 resource planning work.

The fourth of these assumptions involved DSM. Since 1994, FPL's resource planning work has used the DSM MW called for in FPL's approved DSM goals as a "given" in its analyses. This was again the case in FPL's 2000 planning work as its recently approved new DSM goals through the year 2009 were taken as a given.

³ Once all of the purchase negotiations are finalized, FPL will inform the Florida Public Service Commission of the details of the purchases including names of selling entities, sizes of purchases, lengths of purchases, etc.

The first place in which these assumptions and much of the other updated information and assumptions are used is the first fundamental step: the determination of the magnitude and the timing of FPL's resource needs. This determination is accomplished by system reliability analyses which are typically based on a dual planning criteria of a minimum peak period reserve margin of 15% (FPL applies this to both Summer and Winter peaks) and a maximum loss-of-load probability (LOLP) of 0.1 days/year criteria. Both of these criteria are commonly used throughout the utility industry. FPL also used a "third" reliability criterion in its 2000 planning work: a minimum 20% Summer and Winter reserve margin which was applied in the analysis starting in mid-2004 due to a joint settlement reached among FPL, FPC, TECO, and the FPSC in the FPSC's Docket No. 981890-EU.

Historically, two types of methodologies, deterministic and probabilistic, have been employed in system reliability analyses. The calculation of excess firm capacity at the annual system peaks (reserve margin) is the most common method and this relatively simple calculation can be performed on a spreadsheet. It provides an indication of how well a generating system can meet its native load during peak periods. However, deterministic methods do not take into account probabilistic-related elements such as: unit reliability; unit numbers and sizes (i.e., two 50 MW units which can be counted on to run 90% of the time are more valuable in regard to utility system reliability than is one 100 MW unit which can also be counted on to run 90% of the time); and the value of being part of an interconnected system.

Therefore, probabilistic methodologies have been used to provide additional information on the reliability of a generating system. There are a number of probabilistic methods that are being used to perform system reliability analyses. Of these, the most widely used is loss-of-load probability or LOLP. Simply stated, LOLP is an index of how well a generating system may be able to meet its demand (i.e., a measure of how often load may exceed available resources). In contrast to reserve margin, the calculation of LOLP looks at the daily peak demands for each year, while taking into consideration such probabilistic events as the unavailability of individual generators due to scheduled maintenance or forced outages.

LOLP is expressed in units of "number of times per year" that the system demand could not be served. The standard for LOLP accepted throughout the industry is a maximum of 0.1 day per year. This analysis requires a more complicated calculation methodology than does reserve margin analysis.

The end result of the first fundamental step of resource planning is a projection of how many MW are needed to maintain system reliability and of when the MW are needed. This information is used in the second fundamental step: identifying resource options and resource plans which can meet the determined magnitude and timing of FPL's resource needs.

Step 2: Identify Resource Options and Plans Which Can Meet the Determined Magnitude and Timing of FPL's Resource Needs:

The initial activities associated with this second fundamental step of resource planning generally proceed concurrently with the activities associated with Step 1. During Step 2, feasibility analyses of new capacity options are carried out to determine which new capacity options appear to be the most competitive on FPL's system. These analyses also establish capacity size (MW) values, projected construction / permitting schedules, and operating parameters and costs.

The individual new capacity options are then "packaged" into different resource plans which are designed to meet the system reliability criteria. In other words, resource plans are created by combining individual resource options so that the timing and magnitude of FPL's new resource needs are met. The creation of these competing resource plans is typically carried out using dynamic programming techniques.

Therefore, at the conclusion of the second fundamental resource planning step in 2000, a number of different combinations of new resource options (i.e., resource plans) of a magnitude and timing necessary to meet FPL's resource needs were identified. These resource plans were then compared on an economic basis.

Step 3: Determining the Total System Economics:

At the completion of fundamental Steps 1 & 2, the most viable new resource options have been identified, and these resource options have been combined into a number of resource plans which meet the magnitude and timing of FPL's resource needs. The stage is set for comparing the system economics of these resource plans. FPL combines the resource options into resource plans using the EGEAS (Electric Generation Expansion Analysis System) computer model from the Electric Power Research Institute (EPRI) and Stone & Webster Management

Consultants, Inc. The EGEAS model is also used to perform the economic analyses of the resource plans.

The economic analyses of the competing resource plans focus on total system economics. The standard basis for comparing the economics of the competing resource plans is the competing resource plans' impact on FPL's electricity rate levels with the intent of minimizing FPL's levelized system average rate (i.e. a Rate Impact Measure or RIM methodology). However, in cases such as existed for FPL's 2000 planning work in which the DSM contribution was taken as a "given" and the only competing options were new generating units, comparisons of competing resource plans' impacts on electricity rates and on system revenue requirements are equivalent. Consequently, for FPL's 2000 resource planning work, the competing options and plans were evaluated on a present value system revenue requirement basis.

At the conclusion of the analyses carried out in Step 3, a determination of FPL's preferred resource plan was made.

Step 4: Finalizing FPL's 2000 Resource Plan

The results of the previous three fundamental steps' activities were evaluated by FPL management and a decision was made as to what FPL's 2000 resource plan would be. This plan is presented in the following section.

III.B Incremental Resource Additions

FPL's projected incremental generation capacity additions/changes for 2001 through 2010 are depicted in Table III.B.1. (The planned DSM additions are shown separately in Table III.C.1.) These capacity additions/changes will result from a variety of actions including: changes to existing units (which are typically achieved as a result of plant component replacements during major overhauls), changes in the amounts of purchased power being delivered under existing contracts as per the contract schedules or by entering into new purchase contracts, repowering of existing units, projected construction of new units, and conversion of CT's into CC's.

As shown in Table III.B.1, the bulk of the capacity additions are made up of the following items: the repowering of both existing steam units at FPL's Fort Myers site by Summer, 2002; a similar repowering of FPL's Sanford Unit Nos. 5 and 4 by the Summer, 2002, and

the end of 2002, respectively; the construction of four new CT's during the 2001 through 2003 time period followed by their conversion into two CC's in 2005; new firm capacity, short-term purchases in the mid-2001 to mid-2005 time frame; and the construction of eight additional CC units in the 2005 through 2010 time frame.⁴

The increase in the number of CC units which are projected to be built in FPL's 2001 Site Plan, compared to the number of CC units shown in previous Site Plans, is due to three factors. Two of these factors are a higher load forecast and the change from a 15% to a 20% reserve margin criterion.

The third factor is that this year's Site Plan must show for the first time plans for the year 2010. Approximately 930 MW of firm capacity purchases from the Southern Company are scheduled to end in 2010. The end of these purchases requires FPL to replace this capacity, as well as to meet projected load growth for 2010, in a way which meets a minimum 20% reserve margin requirement. While FPL has not yet determined whether it would extend or replace these purchases, or build new capacity to meet its needs, for purposes of this Site Plan it was assumed that the 2010 needs would be met through the addition of unsited CC units. (Note that this is an assumption; FPL may look to extend the purchases or replace them. This decision is not needed for at least several years.)

⁴ FPL's current planning studies have identified new combined cycle units as the generally preferred option to meet future load growth. However, repowering of existing FPL sites remains an alternative to new construction, and FPL will continue to examine this option.

Projected Capacity Changes for FPL ⁽¹⁾		Net Capacity Changes (MW)	
		<u>Winter</u> ⁽²⁾	<u>Summer</u> ⁽³⁾
2001	Changes to existing plants	8	(56)
	Fort Myers Repowering:Initial Phase ⁽⁴⁾	543	894
	Combustion Turbines (2) at Martin ⁽⁵⁾	---	298
	New purchases ⁽⁶⁾	---	196
2002	Fort Myers Repowering:Second Phase	(1)	35
	Combustion Turbines (2) at Martin ⁽⁵⁾	362	---
	Sanford Repowering # 5: Initial Phase ⁽⁷⁾	(394)	---
	Sanford Repowering # 5: Second Phase ⁽⁷⁾	---	567
	Sanford Repowering # 4: Initial Phase ⁽⁷⁾	---	(390)
	New purchases ⁽⁶⁾	50	779
	Changes to existing QF's	---	(9)
2003	Fort Myers Repowering:Second Phase	531	---
	Sanford Repowering # 5: Second Phase	1065	---
	Sanford Repowering # 4: Second Phase	671	957
	Combustion Turbines (2) Fort Myers ⁽⁸⁾	---	298
	Changes to existing QF's	(9)	---
	New purchases ⁽⁶⁾	1025	---
2004	Combustion Turbines (2) Fort Myers	362	---
2005	Changes to existing QF's	(10)	(10)
	New purchases ⁽⁶⁾	(50)	(975)
	Martin Combined Cycle No. 5 ⁽⁹⁾	---	547
	Conversion of MR CT's to CC	---	249
	Conversion of FM CT's to CC	---	249
	Midway Combined Cycle ⁽⁹⁾	---	547
2006	Changes to existing QF's	(133)	(133)
	New purchases	(1025)	---
	Martin Combined Cycle No. 5 ⁽⁹⁾	596	---
	Conversion of MR CT's to CC	234	---
	Conversion of FM CT's to CC	234	---
	Midway Combined Cycle ⁽⁹⁾	596	---
	Martin Combined Cycle No. 6 ⁽⁹⁾	---	547
2007	Martin Combined Cycle No. 6 ⁽⁹⁾	596	---
	Unsitd Combined Cycle #1 ⁽⁹⁾	---	547
2008	Unsitd Combined Cycle #1 ⁽⁹⁾	596	---
2009	Unsitd Combined Cycle #2 ⁽⁹⁾	---	547
	Changes to existing QF's	(51)	(51)
2010	Changes to existing purchases ⁽¹⁰⁾	---	(975)
	Unsitd Combined Cycle #2 ⁽⁹⁾	596	---
	Unsitd Combined Cycle #3 ⁽⁹⁾	---	547
	Unsitd Combined Cycle #4 ⁽⁹⁾	---	547
	Unsitd Combined Cycle #5 ⁽⁹⁾	---	547
TOTALS =		6,392	6,299

Table III.B.1

Projected Capacity Changes for FPL

Note:

- (1) Additional information about these capacity changes and resulting reserve margins is found in Chapter III of this document.
- (2) Winter values are values for January of year shown.
- (3) Summer values are values for August of year shown.
- (4) The initial phase of the Fort Myers repowering project consists of the introduction of operational combustion turbines followed by taking existing steam units out-of-service. The second phase of repowering consists of completing the integration of the combustion turbines, heat recovery steam generators, and steam turbines.
- (5) The two CT's at Martin are scheduled to be in-service in the Summer of 2001. Therefore, the CT's are included in the 2001 Summer reserve margin calculation and are included in the 2002 - on reserve margin calculations for Summer and Winter.
- (6) These are firm capacity, short - term purchases. See Section I.D and III.A. for more details.
- (7) The initial phase of the Sanford repowering project consists solely of taking existing steam units out-of-service; combustion turbine operation is not introduced at this time. The second phase of the repowering consists of integrating the combustion turbines, heat recovery steam generators, and steam turbines.
- (8) The two CT's at Fort Myers are scheduled to be in-service in the Spring of 2003. Therefore, the CT's are included in the 2003 Summer reserve margin calculation and are included in the 2004 - on reserve margin calculations for Summer and Winter.
- (9) All combined cycle units are scheduled to be in-service in June of the year shown. Consequently, they are included in the Summer reserve margin calculation for the in-service year and in both the Summer and Winter reserve margin calculations for subsequent years.
- 10) FPL will be determining at a later date whether to extend or replace these UPS purchases from Southern Company. However, for purposes of this Site Plan, FPL has assumed that the 2010 needs would be met through the addition of unsited combined cycles.

III.C Demand Side Management (DSM)

1. FPL's Current DSM Programs

FPL's currently approved DSM programs are summarized as follows.

Residential Conservation Service: This is an energy audit program which is designed to assist residential customers in understanding how to make their homes more energy-efficient through the installation of conservation measures/practices.

Residential Building Envelope: This program is designed to encourage the installation of energy-efficient ceiling insulation in residential dwellings that utilize whole-house electric air-conditioning.

Duct System Testing and Repair: This program is designed to encourage demand and energy conservation through the identification of air leaks in whole-house air conditioning duct systems and by the repair of those leaks by qualified contractors.

Residential Air Conditioning: This is a program which is designed to encourage customers to purchase higher efficiency central cooling and heating equipment.

Residential Load Management (On Call): This program offers load control of major appliances/household equipment to residential customers in exchange for monthly electric bill credits.

New Construction (BuildSmart): This program encourages the design and construction of energy-efficient homes that cost-effectively reduce coincident peak demand and energy consumption.

Business Energy Evaluation: This program encourages energy efficiency in both new and existing commercial and industrial facilities by identifying DSM opportunities and providing recommendations to the customer.

Commercial/Industrial Heating, Ventilating, and Air Conditioning: This program is designed to encourage the use of high-efficiency heating, ventilating, and air conditioning (HVAC) systems in commercial/industrial facilities.

Commercial/Industrial Efficient Lighting: This program encourages the installation of energy-efficient lighting measures in commercial/industrial facilities.

Business Custom Incentive: This program encourages commercial/industrial customers to implement unique energy conservation measures or projects not covered by other FPL programs.

Commercial/Industrial Load Control: This program is designed to reduce peak demand by controlling customer loads of 200 kW or greater during periods of extreme demand or capacity shortages in exchange for monthly electric bill credits. (This program is closed to new participants in 2000).

Commercial/Industrial Demand Reduction: This program (which starts in 2001) is similar to the Commercial/Industrial Load Control mentioned above by continuing the objective to reduce peak demand by controlling customer loads of 200 kW or greater during periods of extreme demand or capacity shortages in exchange for monthly electric bill credits.

Commercial/Industrial Building Envelope: This program encourages the installation of energy-efficient building envelope measures such as window treatments and roof/ceiling insulation for commercial/industrial facilities.

Business On Call: This program offers load control of central air conditioning units to both small, non-demand-billed and medium, demand - billed commercial/industrial customers in exchange for monthly electric bill credits.

2. Research and Development

FPL's DSM Plan continues to support research and development activities. Historically, FPL has performed extensive DSM research and development. FPL will continue such activities not only through its Conservation Research and Development program, but also through individual research projects. These efforts will examine a wide variety of technologies which build on prior FPL research where applicable and will expand the research to new and promising technologies as they emerge.

Conservation Research and Development Program

FPL's Conservation Research and Development Program is designed to evaluate emerging conservation technologies to determine which are worthy of pursuing for program development and approval. FPL has researched a wide variety of technologies and from that research has been able to develop new programs such as Residential New Construction, Commercial/Industrial Building Envelope, and Business On Call.

Cool Communities Research Project

Cool Communities is a concept developed by American Forests to demonstrate the extent to which strategic tree planting and surface color lightening can cool ambient air temperature and impact energy consumption. This research project is designed to evaluate emerging conservation technologies and practices associated with residential structures to determine which are worthy of pursuing for program development and approval. The project, which consists of data gathering, statistical regression analysis, and economic evaluation, will quantify savings from lightened roof color and tree shading of homes.

Commercial/Industrial New Construction Research Project

The objective of this project is to identify cost-effective opportunities in the commercial/industrial new construction market. If cost-effective opportunities are identified, the results of this effort may be used to design a new construction program (and other market intervention strategies) with the ultimate goal being to reduce building demand and energy use beyond that required by the Florida Energy Efficiency Code.

Low Income Weatherization Retrofit Project

This R&D project is investigating cost-effective methods of increasing the energy efficiency of FPL's low - income customers. The research project addresses the needs of low - income housing retrofits by providing monetary incentives to various housing authorities including weatherization agency providers, (WAPS), and non-weatherization agency providers (non-WAPS). These incentives are used by the housing authorities to leverage their funds to increase the overall energy efficiency of the homes they are retrofitting. FPL either conducts a home energy survey, trains housing authority employees to perform FPL home energy surveys, accept

the National Energy Audit (NEAT) (as supplemented to capture water heating recommendations not included in the NEAT audit), or approves similar FPL - approved audits conducted by weatherization providers to determine the need for energy efficient retrofit measures for each home. FPL has designed the project so as to minimize extra work for the retrofit housing authorities.

Photovoltaic Research, Development and Education Project

Photovoltaic (PV) roof-tile systems are a relatively new technology which directly replaces existing roofing materials such as shingles and standing-rib roofing with PV materials. These PV materials have the same water - proofing characteristics as conventional roofing materials. This project is consistent with the Federal Government's Million Solar Roofs initiative. However, based on FPL's research to - date, a primary hurdle to the physical installation of PV systems, whether roofing materials or flat plate collectors, is the lack of awareness, understanding, and acceptance by local building officials. For the most part, these officials are unclear about how these systems work and how to address these systems as part of the building, permitting, and inspection process. This creates barriers toward the use of this technology.

Green Energy Project

FPL has recently finished an R&D project addressing customer acceptance of green energy where donations were used as the funding mechanism for the purchase and installation of utility grid connected PV systems. This project raised in excess of \$89,500 and a 10.1 kW (dc) PV system has been constructed at FPL's Martin power plant site.

FPL is now investigating potential customer acceptance of green pricing rates in its Green Energy Project. Under this project, FPL will purchase electric energy generated from new renewable resources including solar-powered technologies, biomass energy, landfill methane, wind energy, low impact hydroelectric energy, and/or other renewable resources. Participating customers will be charged higher "green" electric rates for utilizing electric energy derived from these sources.

Real-Time Pricing

Although not part of FPL's approved DSM Plan, FPL continues to research new conservation/efficiency options such as Real-Time Pricing. This option is an

experimental service offering for large C/I customers designed to evaluate customer load response to hourly, marginal cost-based energy prices provided on a day-ahead basis.

3. FPL's DSM MW Goals

FPL's DSM implementation plan is designed to meet currently approved DSM Goals for 2000 – 2009. The combined total residential and commercial/industrial Summer MW reduction values from FPL's DSM Goals for 2000 – 2009 are presented in Table III C.1. FPL has already implemented approximately 2,680 MW at the meter of DSM through 2000.

**FPL's Summer MW Reduction Goals for DSM
(At the Meter)**

Year	Cumulative Summer MW
2000	122
2001	200
2002	269
2003	339
2004	410
2005	484
2006	554
2007	625
2008	697
2009	795

Table III.C.1

III.D Non-Utility Generation Additions

As previously mentioned in Section III.A, FPL is entering into a number of new firm capacity, short-term purchases for the mid-2001 to the mid-2005 time frame. Negotiations for these purchases were not yet completed at the time this document went to print, but some of these purchases are expected to be from non-utility generating facilities. Once all of the purchase negotiations are finalized, FPL will inform the Florida Public Service Commission of the details of the purchases.

Tables I.B.1 and I.B.2 present the previously contracted cogeneration/small power production facilities which are addressed in FPL's resource planning.

III.E Transmission Plan

The 2001 - 2010 transmission plan will allow for the reliable delivery of the required capacity and energy for FPL's retail and wholesale customers. The following table presents FPL's proposed future additions of 230 KV and 500 KV bulk transmission lines.

**List of Proposed Power Lines
2001 – 2010**

OWNER	LINE TERMINAL (FROM)	LINE TERMINAL (TO)	NEW CIRCUIT MILES	COMMERCIAL IN-SERVICE DATE (Mo/YR)	NOMINAL OPERATING VOLTAGE (KV)
FPL	Flagami-Turkey Point	Galloway	1.80	Jan-01	230
FPL	Broward-Parkland	Ranch	9.50	Apr-01	230
FPL	Calusa	Fort Myers	1.60	Apr-01	230
FPL	Broward-Corbett	Rainberry	1.75	Jun-01	230
FPL	Greynolds	Laudania	6.70	Jun-01	230
FPL	Poinsett	Sanford	45.00	Jun-01	230
FPL	Poinsett	Sanford	45.00	Jun-01	230
FPL	Fort Myers	Orange River	1.80	Dec-01	230
FPL	Brevard	Malabar	27.00	Jun-02	230
FPL	Broward-Goolsby	Yamato	2.50	Jun-02	230
FPL	Andytwon	Pennsuco	2.00	Jun-03	230
FPL	Broward-Corbett	Yamato	12.50	Jun-03	230
FPL	Cortez	Johnson	11.00	Jun-03	230
FPL	Dade	Overtwon	11.00	Jun-03	230
FPL	Broward-Corbett	Marymount-Yamato	0.25	Jun-03	230
FPL	Yulee	Oneil	6.50	Jun-04	230
FPL	Indiantown	Martin	11.80	Jun-06	230
FPL	Conservation	Levee	36.00	Jun-08	500

Table III.E.1

In addition, there will be transmission facilities needed to connect FPL's projected capacity additions to the system transmission grid. These integrated transmission facilities for the projected capacity additions at FPL's existing Fort Myers, Sanford, Martin, and Midway sites are described below. Since the projected capacity additions for 2007 through 2010 are as-yet unsited, no "integrated" transmission facilities information is provided. This information may be provided in future Site Plan documents once a site is selected.

It should be noted that FPL currently proposes to transfer its transmission facilities to a for-profit transmission company (Grid Florida) which is being formed in response to FERC Order 2000. Once that transfer is completed, FPL will receive transmission service from Grid Florida which will be responsible for transmission planning in the future.

III.E.1 Integrated Transmission Facilities at Martin

The work required to integrate the incremental capacity projected to be added at Martin from two new CT units with the FPL grid is as follows:

I. Substation:

1. Build one collector bus with 3 breakers each to connect the CT's and the start-up transformer.
2. Add two main step-up transformers (2-200 MVA), one for each CT unit.
3. Add the start-up transformer.
4. Add bus breaker in bay #4 to connect the collector bus in - between this new breaker and breaker 154.
5. Add relays and other protective equipment.

II. Transmission:

1. Construct one string bus to connect the collector and main switchyard.

MARTIN COMBUSTION TURBINES

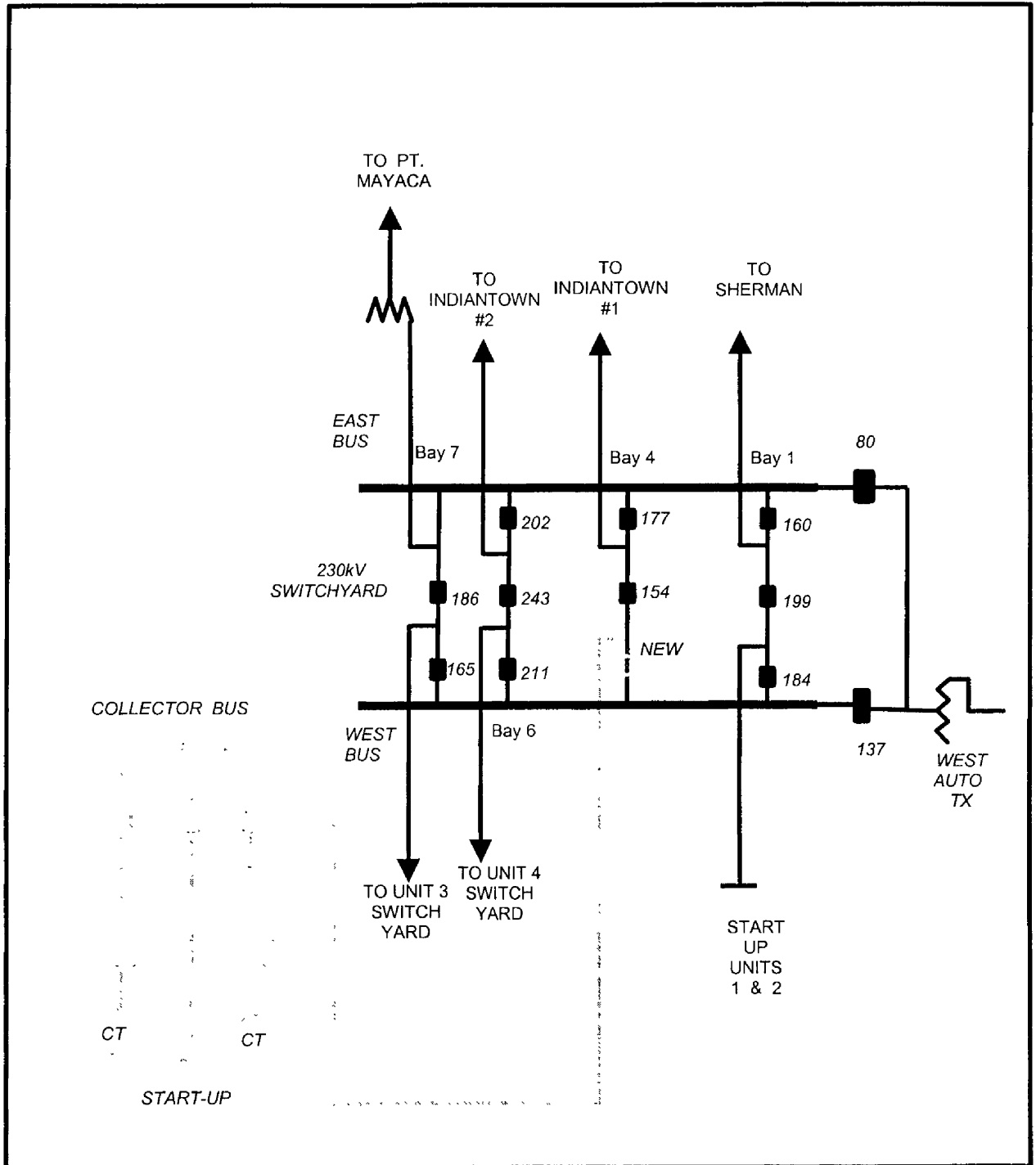

Figure III.E.1

III.E.2 Integrated Transmission Facilities at Fort Myers

The work required to integrate the repowering capacity addition at Fort Myers with the FPL grid is as follows:

I. Substation:

1. Build two collector busses with 3 breakers each to connect 3 CT's on each one. Add another breaker to one of those collector buses to connect the start-up transformer.
2. Add the six main step-up transformers (200MVA/each), one for each CT.
3. Add the start-up transformer.
4. Add a three - breaker bay in the 230 kV substation to connect one of the collector buses and a new transmission line to Calusa.
5. Add a three - breaker bay in the 230 kV substation to connect the other collector bus and a new transmission line to Orange River 230 kV.
6. Add a two - breaker bay at Orange River 230 kV substation to connect the new line from Fort Myers.
7. Add a two - breaker bay at Calusa 230 kV substation to connect the new line from Fort Myers.
8. Replace breakers 3 and 36 (rated 37.6 kA) on bay 9N with new ones rated 63 kA.
9. Add relay and other protective equipment at Fort Myers, Orange River, and Calusa substations.

II. Transmission:

1. Build a new 230 kV line from Fort Myers to Orange River (approximately 2.57 miles) similar to the existing circuits which are bundle 2-1431 ACSR 2580 Amps (1028 MVA) each.
2. Build a new 230 kV line from Fort Myers to Calusa (approximately 1.58 miles) using 1431 ACSR conductor rated 1600 Amps (637 MVA).
3. Add protection and control equipment for the new lines.

FORT MYERS REPOWERING PROJECT

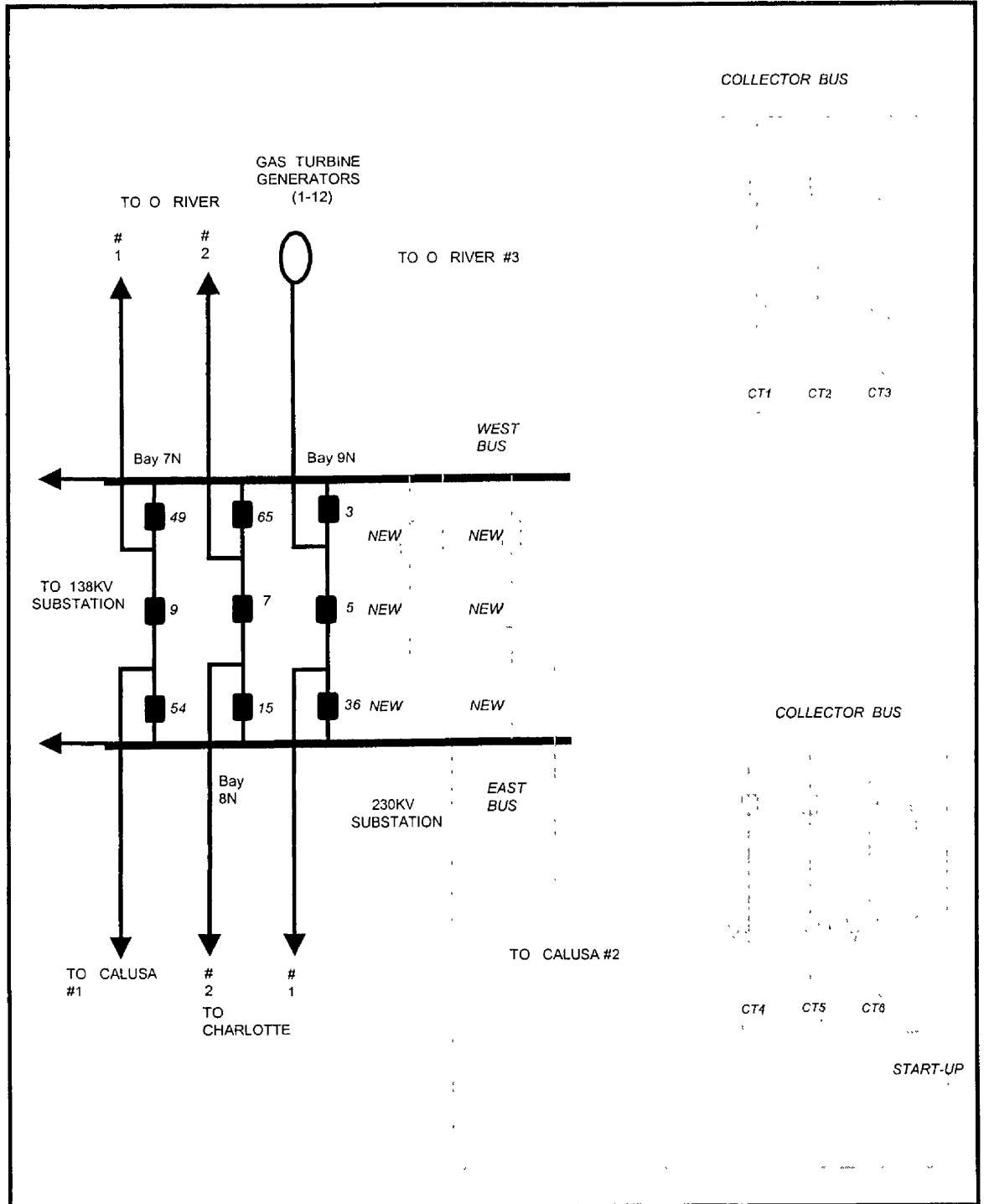

Figure III.E.2

III.E.3 Integrated Transmission Facilities at Sanford

The work required to integrate the repowering capacity additions at Sanford with the FPL grid is as follows:

I. Substation:

1. Build four collector buses with 2 breakers each to connect 2 CT's on each one. Add another breaker to one of those collector buses to connect the start-up transformer.
2. Add the eight main step-up transformers (200MVA/each), one for each CT.
3. Add the start-up transformer.
4. Build a new substation with 1 new three - breaker bay, 1 new two - breaker bay, and using 2 existing three - breaker bays to connect 2 collector buses and the new transmission lines.
5. Build 2 new three - breaker bays and 1 new two - breaker bay at the existing substation to connect 2 collector buses.
6. Move the Volusia #2 line terminal from the existing yard to the new 230 KV yard.
7. Add a three - breaker bay at Poinsett 230 kV substation to connect the new lines from Sanford.
8. Add relay and other protective equipment at Sanford and at Poinsett substations.

II. Transmission:

1. Build two new 230 kV lines from the new Sanford to Poinsett (approximately 45 miles each) with conductor rated for 1600 Amps.
2. Add protection and control equipment for the new lines.
3. Upgrade the Volusia #2 transmission line to 1475 Amps.

SANFORD REPOWERING PROJECT

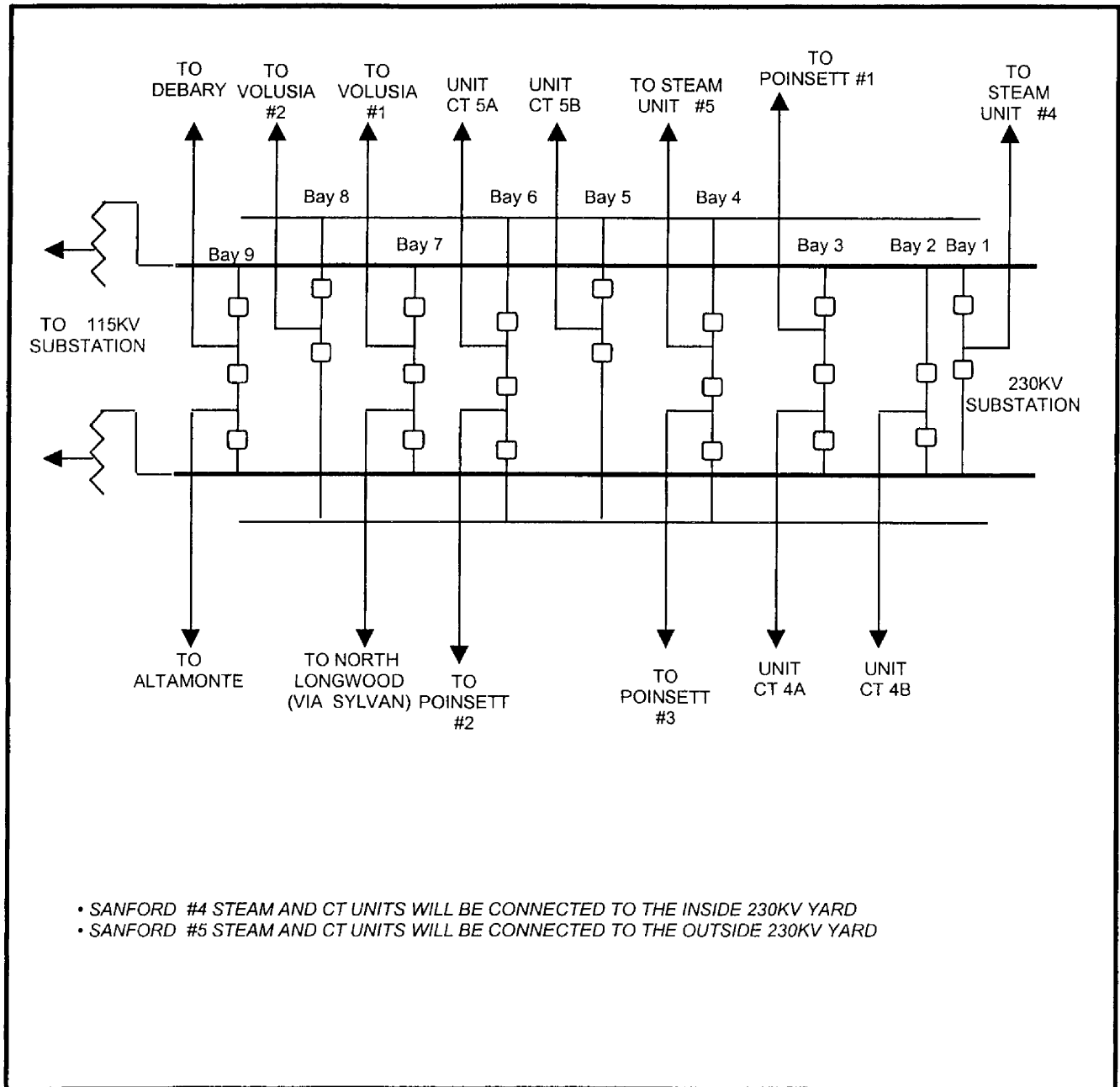

Figure III.E.3

III.E.4 Integrated Transmission Facilities at Fort Myers

The work required to integrate the Fort Myers capacity expansion from two new CT units with the FPL grid is as follows:

I. Substation:

1. Build one collector bus with 2 breakers each to connect 2 CT's on each one. Add another breaker to the collector bus to connect the start-up transformer.
2. Add the two main step-up transformers (200MVA/each), one for each CT.
3. Add the start-up transformer.
4. Disconnect the existing Fort Myers GT collector bus from the Fort Myers 230kV switchyard.
5. Add two breakers at Orange River 230 kV substation to connect the new line from the Fort Myers GT collector bus.
6. Connect the new Fort Myers collector bus to the Fort Myers 230kV switchyard.
7. Connect the Fort Myers collector bus to the Fort Myers 230kV switchyard.
8. Replace 4 breakers at the existing Fort Myers 230 kV switchyard.
9. Add relay and other protective equipment at Fort Myers and Orange River substations.

II. Transmission:

1. Build a new 230 kV line from the Fort Myers GT collector bus to Orange River (approximately 2.57 miles) similar to the existing circuits which are bundle 2-1431 ACSR 2580 Amps (1028 MVA) each.
2. Add protection and control equipment for the new line.

FORT MYERS COMBUSTION TURBINES

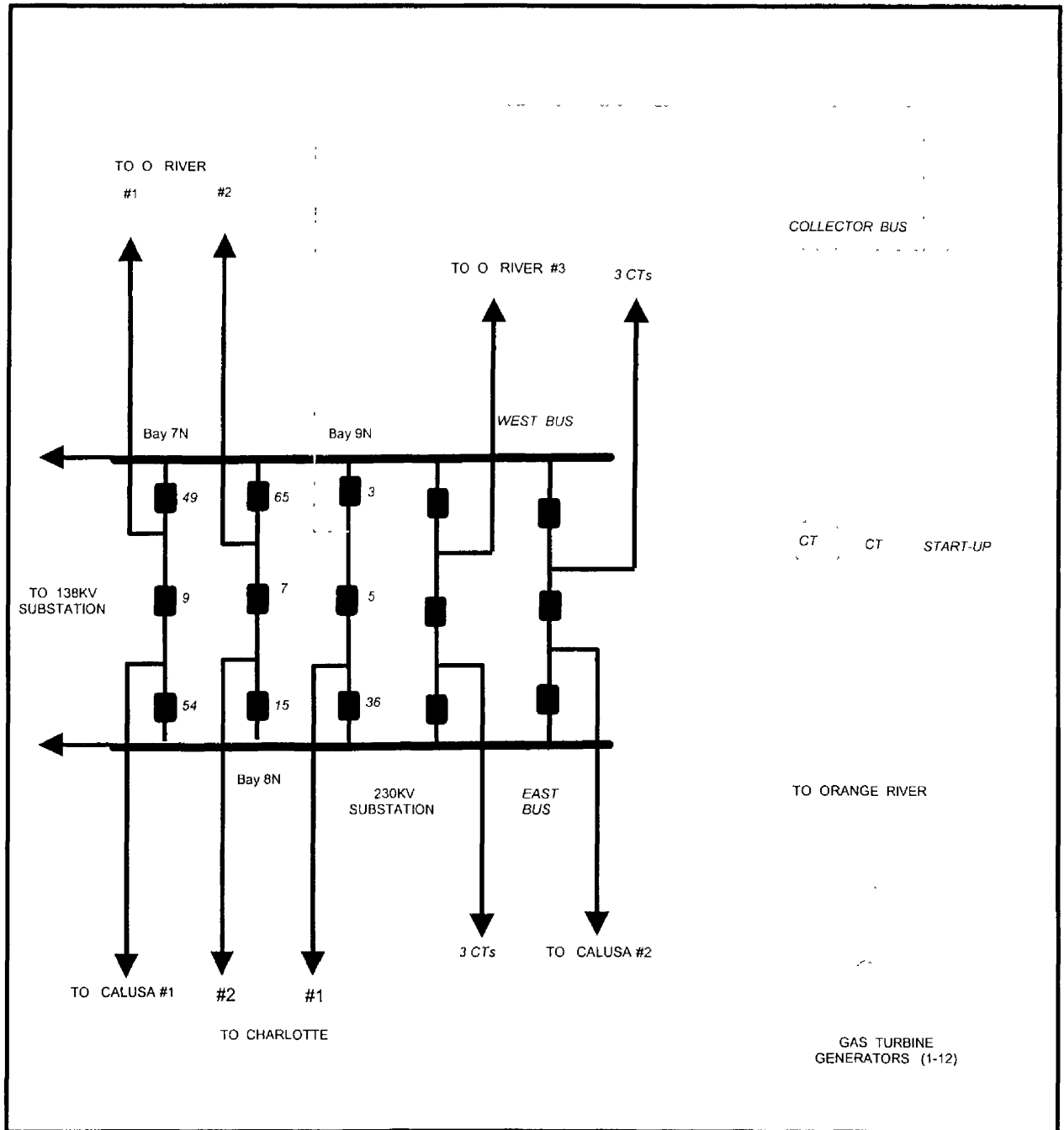

Figure III.E.4

III.E.5 Integrated Transmission Facilities at Martin

The work required to integrate the incremental capacity projected to be added at Martin from two new combined cycle units, Martin Nos. 5 and 6, with the FPL grid is as follows:

I. Substation:

1. Build two collector busses with 3 breakers each to connect the CT's, the ST units, and the start-up transformers.
2. Add the four main step-up transformers (2-400 MVA and 2-200 MVA), one for each CT and one for each ST unit.
3. Add the start-up transformers.
4. Add a new three-breaker bay (bay #3) to connect the Martin #6 collector bus and the existing start-up for units 1 &2.
5. Connect the Martin #5 collector bus to bay #1 between breakers 199 and 184.
6. Add relays and other protective equipment.
7. Split the 230 kV bus in order to reduce fault current levels in the switchyard. This will effectively separate units 3 and 4 from the new units 5 and 6. The 500/230 kV autotransformer #1 will remain connected to the units 3 and 4 switchyard and the new autotransformer #2 will connect the units 5 and 6 switchyard to the 500 kV bus.
8. Add the second 500/230 kV autotransformer and connect it to breaker 80 and the 230 kV side which is tied to the switchyard for units 5 and 6.
9. Add a single phase 230/500 kV, 500 MVA transformer to be used as a spare for either autotransformer.
10. Add a two-breaker bay (bay 8) to connect the new Martin-Indiantown 230kV line.
11. Add a breaker and line terminal at Indiantown to connect the new Martin-Indiantown 230kV line.
12. Add relays and other protective equipment.

II. Transmission:

1. Construct two string buses to connect the collector and main switchyards.
2. Uprate the Pratt & Whitney-Indiantown 230 kV circuit from 2020 Amps to 2520 Amps.
3. Uprate the Pratt & Whitney-Ranch 230 kV circuit from 2020 Amps to 2520 Amps.
4. Build a new 230kV line from Martin to Indiantown (approximately 11.8 miles) similar to existing circuit which is 2-795B ACSR 2290 Amps (912MVA).

MARTIN COMBINED CYCLE UNITS

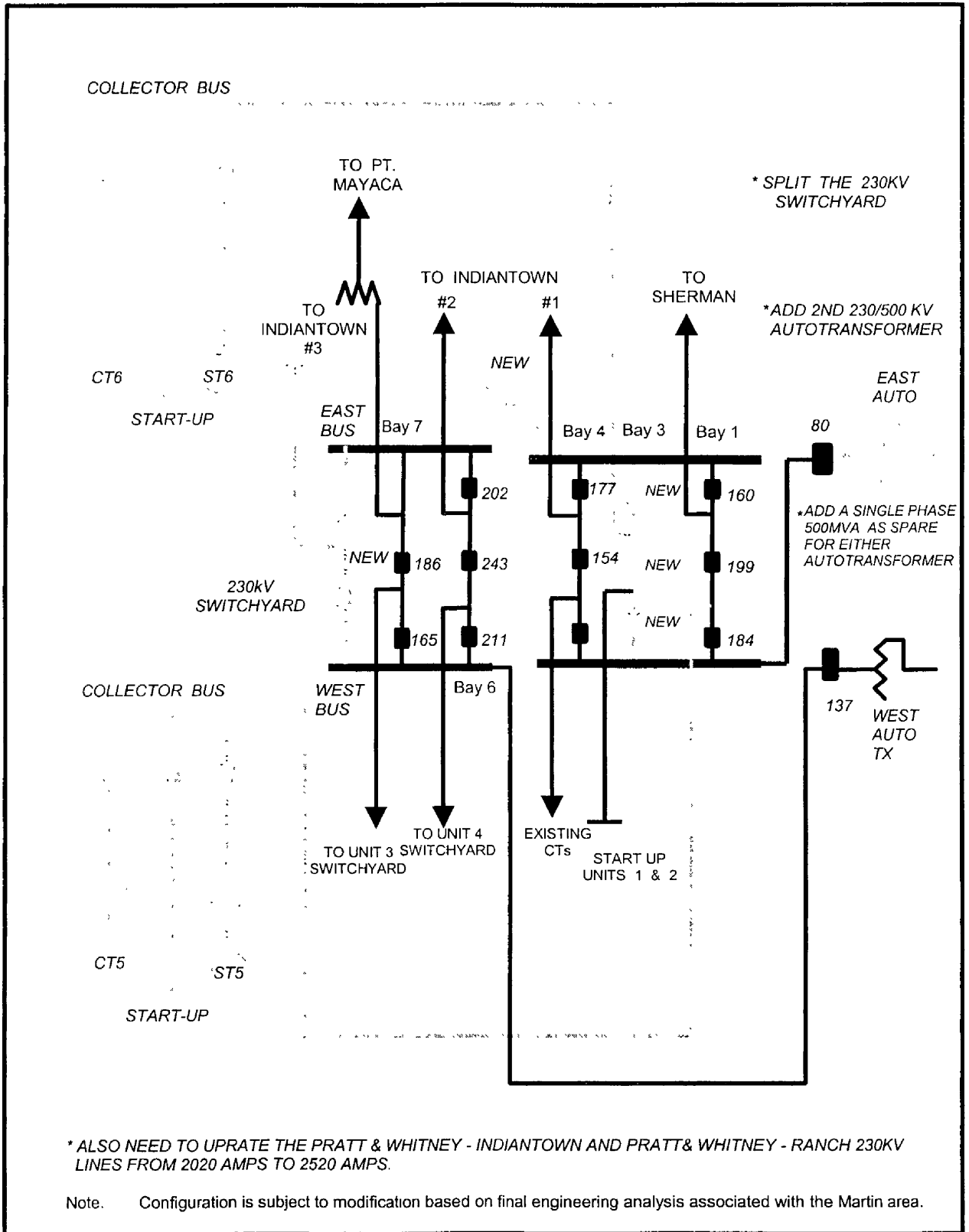

Figure III.E.5

III.E.6 Integrated Transmission Facilities at Martin

The work required to integrate the conversion of two existing CT's at Martin add a new steam unit into a combined cycle unit with the FPL grid is as follows:

I. Substation:

1. Add one breaker to the collector bus to connect the steam unit step-up transformer (300MVA).
2. Add relay and other protective equipment at the Martin substation.

II. Transmission:

1. None.

MARTIN CONVERSION OF CT'S – TO - CC

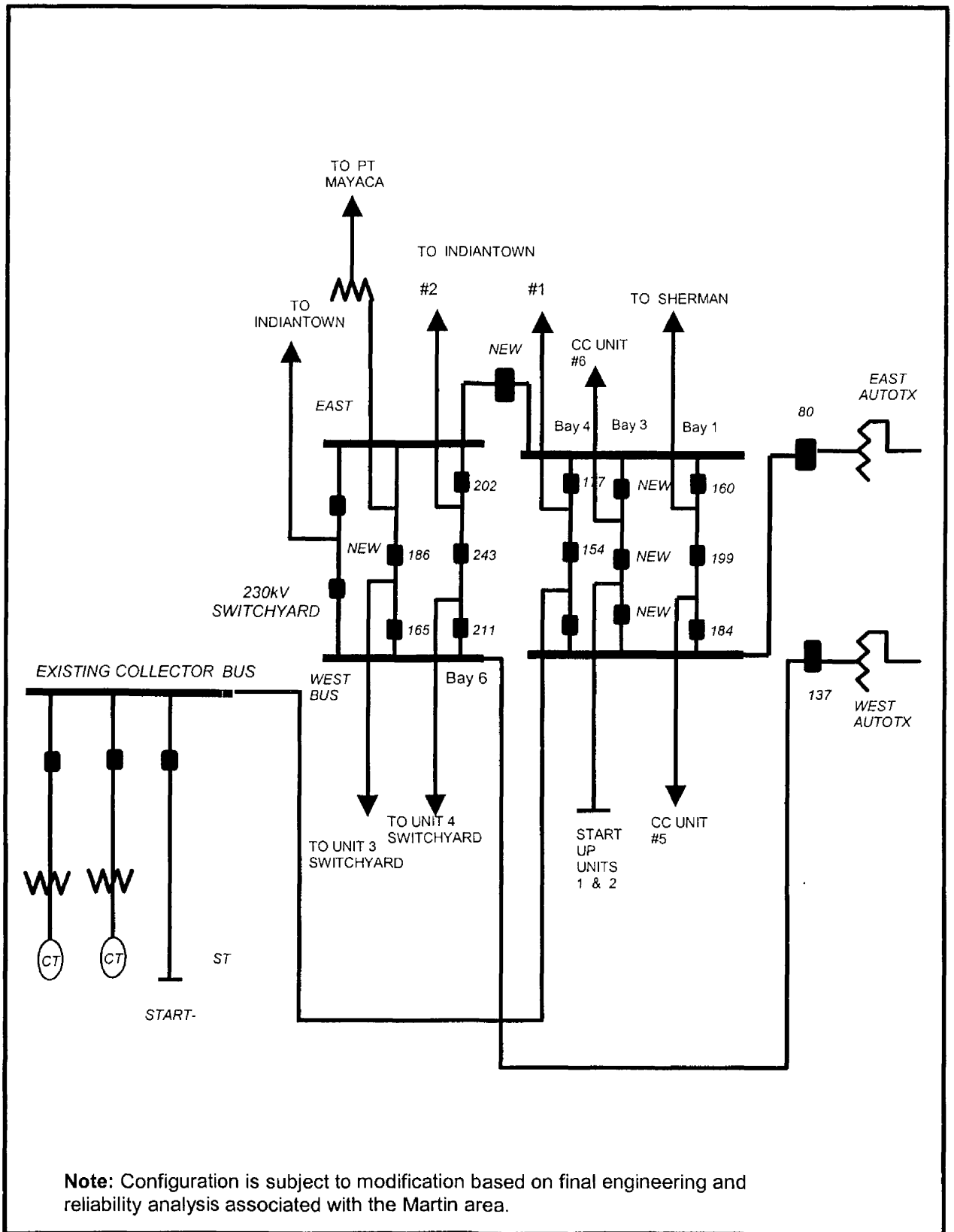

Figure III.E.6

III.E.7 Integrated Transmission Facilities at Fort Myers

The work required to integrate the conversion of two existing CT's at Fort Myers into a combined cycle unit with the FPL grid is as follows:

I. Substation:

1. Add one breaker to the collector bus to connect the steam unit step-up transformer (300MVA).
2. Add relay and other protective equipment at the Fort Myers substation.

II. Transmission:

1. None.

FORT MYERS CONVERSION OF CT'S - TO - CC

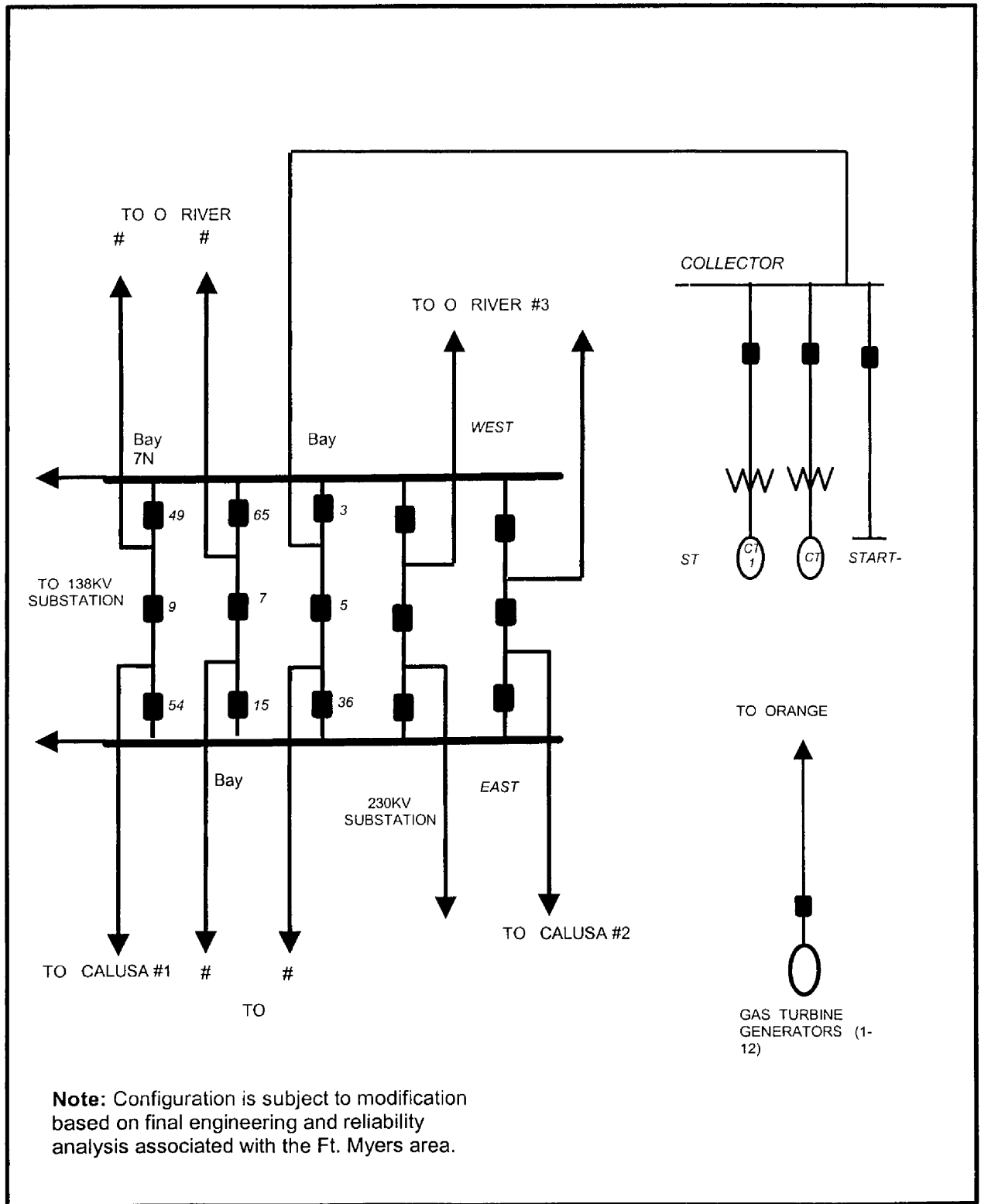

Figure III.E.7

II.E.8 Integrated Transmission Facilities at Midway

The work required to integrate the incremental capacity projected to be added at Midway from a new combined cycle unit with the FPL grid is as follows:

I. Substation:

1. Build one collector bus with 4 breakers to connect the CT's, the ST units, and the start-up transformers.
2. Add the three main step-up transformers (2-225 MVA, 1-300 MVA), one for each CT and one for the ST unit.
3. Add the start-up transformer.
4. Add a new two-breaker bay to connect the Midway collector bus.
5. Add relays and other protective equipment.

II. Transmission:

1. Construct one string bus to connect the collector and the Midway 230kV yard.

MIDWAY COMBINED CYCLE UNIT

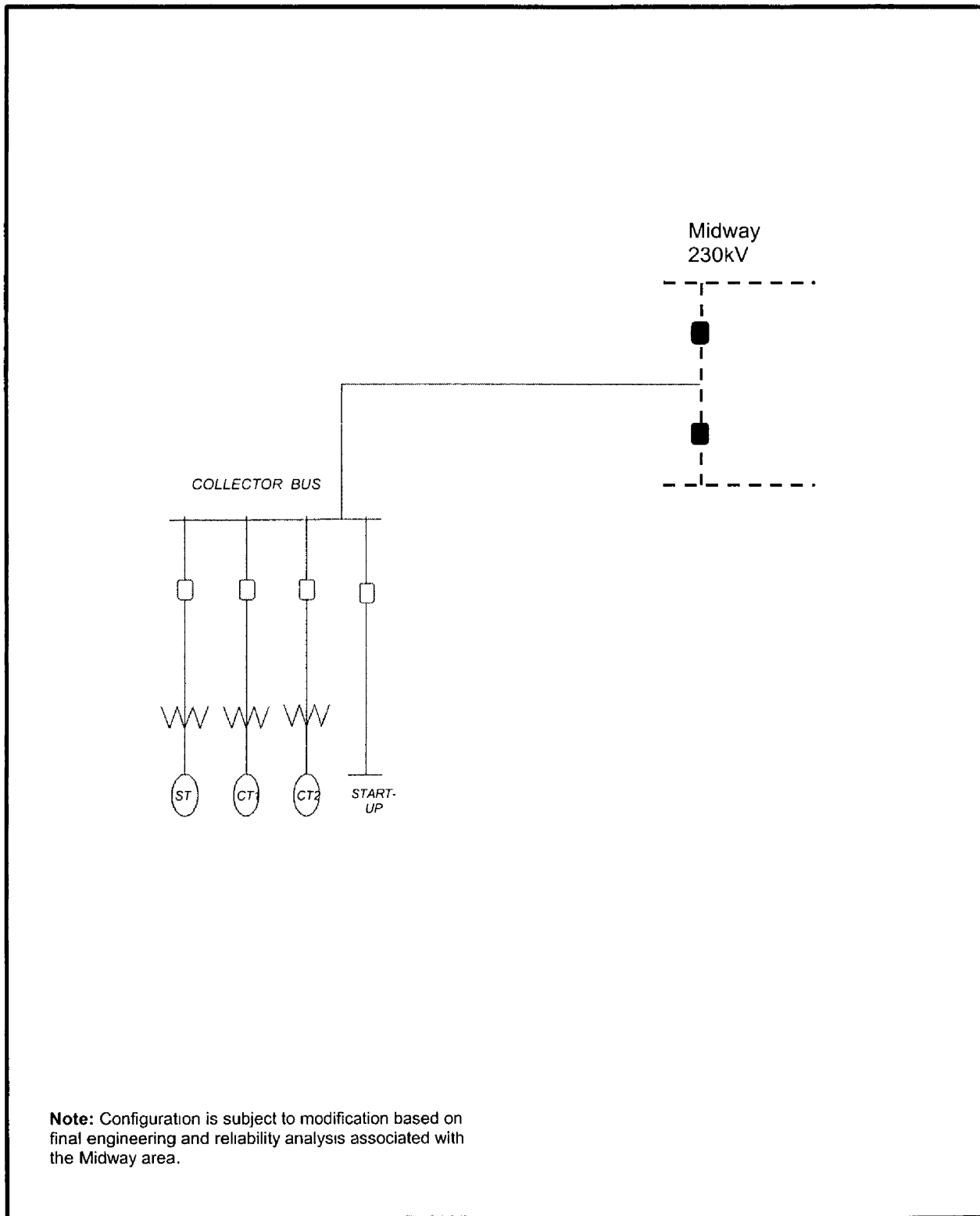

Figure III.E.8

III.F. Renewable Resources

FPL has been the leading Florida utility in examining ways to utilize renewable energy technologies to meet its customers' current and future needs. FPL has been involved since 1976 in renewable energy research and development and in facilitating the implementation of various technologies.

FPL assisted the Florida Solar Energy Center (FSEC) in the late 1970's in demonstrating the first residential solar photovoltaic (PV) system east of the Mississippi. This PV installation at FSEC's Brevard County location was in operation for over 15 years and provided valuable information about PV performance capabilities on both a daily and annual basis in Florida. FPL later installed a second PV system at the FPL Flagami substation in Miami. This 10 kilowatt (KW) system was placed into operation in 1984. The testing of this PV installation was completed, and the system was removed, in 1990 to make room for substation expansion.

For a number of years, FPL maintained a thin-film PV test facility located at the FPL Martin Plant site. The FPL PV test facility was used to test new thin-film PV technologies and to identify design, equipment, or procedure changes necessary to accommodate direct current PV facilities into the FPL system. Although this testing has ended, the site is now the home for PV capacity which was installed as a result of FPL's recent Green Pricing effort (which is discussed on the following page).

In terms of utilizing renewable energy sources to meet its customers' needs, FPL initiated the first and only utility-sponsored conservation program in Florida designed to facilitate the implementation of solar technologies by its customers. FPL's Conservation Water Heating Program, first implemented in 1982, offered incentive payments to customers choosing solar water heaters. Before the program was ended (due to the fact that it was not cost-effective), FPL paid incentives to approximately 48,000 customers who installed solar water heaters.

In the mid-1980's, FPL introduced another renewable energy program. FPL's Passive Home Program was created in order to broadly disseminate information about passive solar building design techniques which are most applicable in Florida's climate. Complete designs and construction blueprints for 6 passive homes were created by 3 Florida architectural firms with the assistance of the FSEC and FPL. These designs and blueprints were available to customers at a low cost. During its existence, this program was popular and received a U.S. Department of Energy award for innovation. The program was

eventually phased out due to a revision of the Florida Model Energy Building code. This revision was brought about in part by FPL's Passive Home Program. The revision incorporated into the Code one of the most significant passive design techniques highlighted in the program: radiant barrier insulation.

In early 1991, FPL received approval from the Florida Public Service Commission to conduct a research project to evaluate the feasibility of using small PV systems to directly power residential swimming pool pumps. This research project was completed with mixed results. Some of the performance problems identified in the test may be solvable, particularly when new pools are constructed. However, the high cost of PV, the significant percentage of sites with unacceptable shading, as well as customer satisfaction issues remain as significant barriers to wide acceptance and use of this particular solar application.

More recently, FPL has analyzed the feasibility of encouraging utilization of PV in another, potentially much larger way. FPL's basic approach does not require all of its customers to bear PV's high cost, but allows customers who are interested in facilitating the use of renewable energy the means to do so. FPL's initial effort to implement this approach allowed customers to make voluntary contributions into a separate fund, which FPL used to make PV purchases in bulk quantities. PV modules were then installed and delivered PV-generated electricity directly into the FPL grid. Thus, when sunlight is available at this site(s), the PV-generated electricity displaces an equivalent amount of fossil fuel-generated electricity.

FPL's basic approach, which has been termed Green Pricing, was initially discussed with the FPSC in 1994. FPL's initial effort to implement this approach were then formally presented to the FPSC as part of FPL's DSM Plan in 1995 and FPL received approval from the FPSC in 1997 to proceed. FPL initiated the effort in 1998 and received approximately \$89,000 in contributions which significantly exceeded the goal of \$70,000. FPL has purchased the PV modules and installed them at FPL's Martin plant site.

As previously discussed, FPL initiated two new renewable efforts in 2000. FPL's first new initiative in 2000 was the Green Energy Project which is a second, different attempt to implement the basic Green Pricing approach. Under this project FPL will purchase electric energy generated from new renewable resources. The project offers to meet all, or part of, a customer's load with generation from new renewable resources, with the remaining portion of that load being served by the Company's conventional generating facilities.

Participants will be residential (and possibly commercial) customers who will pay higher ("green" rates) for electricity provided from these renewable sources.

The second effort initiated in 2000 is FPL's Photovoltaic Research, Development and Education Project. This demonstration project's objectives are to increase the public awareness of roof tile PV technologies, provide data to determine the durability of this technology and its impact on FPL's electric system, collect demand and energy data to better understand the coincidence between PV roof tile system output and FPL's system peaks as well as the energy capabilities of roof tile PV systems, and assess the homeowner's financial benefits and costs of PV roof tile systems.

Finally, FPL has also facilitated renewable energy projects (facilities which burn bagasse, waste wood, municipal waste, etc.). Firm capacity and energy, and as-available energy, have been purchased by FPL from these developers. (Please refer to Tables I.B.1 and I.B.2).

III.G FPL's Fuel Mix and Fuel Price Forecasts

1. FPL's Fuel Mix

Until the mid-1980's, FPL relied primarily on a combination of oil, natural gas, and nuclear energy to generate electricity. In 1986, coal was first added to the fuel mix, allowing FPL to meet its customers' energy needs with a more diversified mix of energy sources. Additional coal resources have been added with the acquisition (76%) of Scherer Unit # 4. In 1997, petroleum coke was added to the fuel mix as a blend stock with coal at the St. Johns River Power Park.

2. Fuel Price Forecasts

FPL's long-term oil price forecast assumes that worldwide demand for petroleum products will grow moderately throughout the planning horizon. Non-OPEC crude oil supply is projected to increase as new and improved drilling technology and seismic information will reduce the cost of producing crude oil and increase both recovery from existing fields and new discoveries. However, the rate of increase in non-OPEC supply is projected to be slower than that of petroleum demand, resulting in an increase in OPEC's market share throughout the planning horizon. As OPEC gains market share, prices for petroleum products are projected to increase.

FPL's natural gas price forecast assumes that domestic demand for natural gas will grow throughout the planning horizon, primarily due to increased requirements for electric generation. Domestic natural gas production will increase as new and improved drilling technology and seismic information will reduce the cost of finding, developing, and producing natural gas fields. The rate of increase in domestic natural gas production is assumed to be slower than that of demand, with the balance being supplied by increased Canadian and liquefied natural gas (LNG) imports. As demand for natural gas in Florida grows, it is anticipated that based on natural gas users' commitments, the Florida Gas Transmission pipeline system will be augmented/expanded and/or a new pipeline will be constructed to meet the growth in demand.

Schedule 5
Fuel Requirements 1/

Fuel Requirements	Units	Actual 2/		Forecasted									
		1999	2000	2001	2002	2003	2004	2005	2006	2007	2008	2009	2010
(1) Nuclear	Trillion BTU	268	268	257	263	258	258	263	258	257	263	258	257
(2) Coal	1,000 TON	3,107	4,170	3,788	3,552	3,705	3,556	3,629	4,019	3,795	3,817	4,073	3,821
(3)													
(4) Residual(FO6)- Total	1,000 BBL	36,475	36,859	32,769	26,951	24,455	26,018	19,352	14,059	12,416	12,546	11,973	9,188
(5) Steam	1,000 BBL	36,475	36,859	32,769	26,951	24,455	26,018	19,352	14,059	12,416	12,546	11,973	9,188
(6) Distillate(FO2)- Total	1,000 BBL	488	461	505	315	2,350	2,642	449	381	212	316	181	46
(7) CC	1,000 BBL	3	14	0	0	0	0	0	0	0	0	0	0
(8) CT	1,000 BBL	405	1	0	74	1,959	2,118	406	356	195	289	160	33
(9) Steam	1,000 BBL	80	446	505	241	391	524	42	25	17	27	21	13
(10) Natural Gas -Total	1,000 MCF	193,723	203,234	248,439	299,368	319,720	321,203	378,635	423,640	446,604	452,639	468,918	519,426
(11) Steam	1,000 MCF	73,309	80,967	100,772	76,589	9,521	9,519	7,046	5,361	4,919	4,795	4,736	3,888
(12) CC	1,000 MCF	3,535	117,684	139,066	214,673	308,615	310,455	371,466	418,226	441,651	447,780	464,137	515,507
(13) CT	1,000 MCF	116,879	4,583	8,601	8,106	1,584	1,229	124	54	34	63	45	32

1/ Reflects fuel requirements for FPL only

2/ Source A Schedules

Schedule 6.1
Energy Sources

Energy Sources	Units	Actual 1/		Forecasted									
		1999	2000	2001	2002	2003	2004	2005	2006	2007	2008	2009	2010
(1) Annual Energy Interchange 2/	GWH	8,180	10,092	12,386	11,509	9,611	10,029	9,169	8,492	8,452	8,332	8,282	5,582
(2) Nuclear	GWH	24,706	24,584	23,776	24,284	23,873	23,844	24,284	23,874	23,778	24,331	23,874	23,778
(3) Coal	GWH	6,146	6,977	6,906	6,504	6,711	6,541	6,660	7,307	6,942	6,980	7,398	6,986
(4) Residual(FO6) -Total	GWH	22,903	23,230	20,706	16,871	15,375	16,370	12,211	8,869	7,833	7,911	7,556	5,828
(5) Steam	GWH	22,903	23,230	20,706	16,871	15,375	16,370	12,211	8,869	7,833	7,911	7,556	5,828
(6) Distillate(FO2) -Total	GWH	167	193	213	159	1,674	1,865	331	282	156	232	131	31
(7) CC	GWH	2	9	0	0	0	0	0	0	0	0	0	0
(8) CT	GWH	165	1	0	58	1,461	1,581	312	271	149	220	123	26
(9) Steam	GWH	0	183	213	101	212	284	19	11	7	11	9	5
(10) Natural Gas -Total	GWH	23,098	24,217	28,259	37,053	43,976	44,209	52,388	58,883	62,148	63,034	65,297	72,491
(11) Steam	GWH	7,038	7,840	9,398	7,226	851	849	626	474	435	423	418	346
(12) CC	GWH	15,863	16,064	18,120	29,105	42,983	43,251	51,753	58,406	61,711	62,608	64,876	72,143
(13) CT	GWH	197	313	741	723	143	110	9	3	2	4	3	2
(14) Other 3/	GWH	6,349	6,696	7,240	6,636	5,759	5,814	5,298	4,187	4,082	4,069	3,888	3,540
Net Energy For Load 4/	GWH	91,549	95,989	99,486	103,017	106,979	108,672	110,341	111,894	113,392	114,889	116,427	118,237

1/ Source A Schedules

2/ The projected figures are based on estimated energy purchases from SJRPP and the Southern Companies

3/ Represents a forecast of energy expected to be purchased from Qualifying Facilities, Independent Power Producers, etc

4/ Net Energy For Load is Column 2 on Schedule 3 3 and Column 1 on EIA411 Form 11C

Schedule 6.2
Energy % by Fuel Type

Energy Source	Units	Actual 1/		Forecasted									
		1999	2000	2001	2002	2003	2004	2005	2006	2007	2008	2009	2010
(1) Annual Energy Interchange 2/	%	8.9	10.5	12.4	11.2	9.0	9.2	8.3	7.6	7.5	7.3	7.1	4.7
(2) Nuclear	%	27.0	25.6	23.9	23.6	22.3	21.9	22.0	21.3	21.0	21.2	20.5	20.1
(3) Coal	%	6.7	7.3	6.9	6.3	6.3	6.0	6.0	6.5	6.1	6.1	6.4	5.9
(4) Residual(FO6) -Total	%	25.0	24.2	20.8	16.4	14.4	15.1	11.1	7.9	6.9	6.9	6.5	4.9
(5) Steam	%	25.0	24.2	20.8	16.4	14.4	15.1	11.1	7.9	6.9	6.9	6.5	4.9
(6) Distillate(FO2) -Total	%	0.2	0.2	0.2	0.2	1.6	1.7	0.3	0.3	0.1	0.2	0.1	0.0
(7) CC	%	0.0	0.0	0.0	0.0	0.0	0.0	0.0	0.0	0.0	0.0	0.0	0.0
(8) CT	%	0.2	0.0	0.0	0.1	1.4	1.5	0.3	0.2	0.1	0.2	0.1	0.0
(9) Steam	%	0.0	0.2	0.2	0.1	0.2	0.3	0.0	0.0	0.0	0.0	0.0	0.0
(10) Natural Gas -Total	%	25.2	25.2	28.4	36.0	41.1	40.7	47.5	52.6	54.8	54.9	56.1	61.3
(11) Steam	%	7.7	8.2	9.4	7.0	0.8	0.8	0.6	0.4	0.4	0.4	0.4	0.3
(12) CC	%	17.3	16.7	18.2	28.3	40.2	39.8	46.9	52.2	54.4	54.5	55.7	61.0
(13) CT	%	0.2	0.3	0.7	0.7	0.1	0.1	0.0	0.0	0.0	0.0	0.0	0.0
(14) Other 3/	%	6.9	7.0	7.3	6.4	5.4	5.4	4.8	3.7	3.6	3.5	3.3	3.0
		100	100	100	100	100	100	100	100	100	100	100	100

1/ Source A Schedules

2/ The projected figures are based on estimated energy purchases from SJRPP and the Southern Companies

3/ Represents a forecast of energy expected to be purchased from Qualifying Facilities, Independent Power Producers, etc

**Schedule 7.1
Forecast of Capacity, Demand, and Scheduled
Maintenance At Time Of Summer Peak**

(1)	(2)	(3)	(4)	(5)	(6)	(7)	(8)	(9)	(10)	(11)	(12)	(13)	(14)
Year	Total Installed 1/ Capacity MW	Firm Capacity Import 2/ MW	Firm Capacity Export MW	Firm QF MW	Total Capacity Available 3/ MW	Total Peak 4/ Demand MW	DSM 5/ MW	Firm Summer Peak Demand MW	Reserve Margin Before Maintenance 6/ MW	% of Peak	Scheduled Maintenance MW	Reserve Margin After Maintenance 7/ MW	% of Peak
	2001	17,704	1,509	0	886	20,099	18,150	1,406	16,744	3,355	20.0	0	3,355
2002	17,915	2,288	0	877	21,080	18,801	1,485	17,316	3,764	21.7	0	3,764	21.7
2003	19,170	2,288	0	877	22,335	19,507	1,560	17,947	4,388	24.4	0	4,388	24.4
2004	19,170	2,288	0	877	22,335	19,964	1,639	18,325	4,010	21.9	0	4,010	21.9
2005	20,762	1,313	0	867	22,942	20,433	1,718	18,715	4,227	22.6	0	4,227	22.6
2006	21,309	1,313	0	734	23,356	20,918	1,796	19,122	4,234	22.1	0	4,234	22.1
2007	21,856	1,313	0	734	23,903	21,392	1,874	19,518	4,385	22.5	0	4,385	22.5
2008	21,856	1,313	0	734	23,903	21,788	1,952	19,836	4,067	20.5	0	4,067	20.5
2009	22,403	1,313	0	683	24,399	22,220	2,028	20,192	4,207	20.8	0	4,207	20.8
2010	24,044	382	0	640	25,066	22,722	2,052	20,670	4,396	21.3	0	4,396	21.3

1/ Capacity additions and changes projected to be in-service by June 1st are considered to be available to meet Summer peak loads which are forecasted to occur during August of the year indicated. All values are Summer net MW.

2/ Firm Capacity Imports include all firm capacity purchases whether from out-of-state or in-state.

3/ Total Capacity Available = Col (2) + Col (3) - Col (4) + Col (5)

4/ These forecasted values reflect the Most Likely forecast without DSM.

5/ The MW shown represent cumulative load management capability plus incremental conservation from 1/99 - on. They are not included in total additional resources but reduce the peak load upon which Reserve Margin calculations are based.

6/ Margin (%) Before Maintenance = Col (10)/Col (9)

7/ Margin (%) After Maintenance = Col (13)/Col (9)

Schedule 7.2
Forecast of Capacity , Demand, and Scheduled
Maintenance At Time of Winter Peak

(1)	(2)	(3)	(4)	(5)	(6)	(7)	(8)	(9)	(10)	(11)	(12)	(13)	(14)
Year	Total Installed 1/ Capability MW	Firm Capacity Import 2/ MW	Firm Capacity Export MW	Firm QF MW	Total Capacity Available 3/ MW	Total Peak 4/ Demand MW	DSM 5/ MW	Firm Winter Peak Demand MW	Reserve Margin Before Maintenance 6/ MW	% of Peak	Scheduled Maintenance MW	Reserve Margin After Maintenance 7/ MW	% of Peak
2000/01	17,785	1,319	0	886	19,990	18,840	1,902	16,938	3,052	18.0	0	3,052	18.0
2001/02	17,752	1,369	0	886	20,007	19,333	1,969	17,364	2,643	15.2	0	2,643	15.2
2002/03	20,019	2,394	0	877	23,290	20,122	2,019	18,103	5,187	28.7	0	5,187	28.7
2003/04	20,381	2,394	0	877	23,652	20,555	2,069	18,486	5,166	27.9	0	5,166	27.9
2004/05	20,381	2,344	0	867	23,592	20,986	2,119	18,867	4,725	25.0	0	4,725	25.0
2005/06	22,041	1,319	0	734	24,094	21,413	2,169	19,244	4,850	25.2	0	4,850	25.2
2006/07	22,637	1,319	0	734	24,690	21,841	2,215	19,626	5,064	25.8	0	5,064	25.8
2007/08	23,233	1,319	0	734	25,286	22,186	2,261	19,925	5,361	26.9	0	5,361	26.9
2008/09	23,233	1,319	0	734	25,286	22,586	2,307	20,279	5,007	24.7	0	5,007	24.7
2009/10	23,829	1,319	0	683	25,831	22,978	2,345	20,633	5,198	25.2	0	5,198	25.2

* Denotes actual installed capability and total peak demand. All other assumptions are projections.

1/ Capacity additions and changes projected to be in-service by January 1st are considered to be available to meet Winter peak loads which are forecasted to occur during January of the "second" year indicated. All values are Winter net MW.

2/ Firm Capacity Imports include all firm capacity purchases whether from out-of-state or in-state.

3/ Total Capacity Available = Col (2) + Col (3) - Col (4) + Col (5)

4/ These forecasted values reflect the Most Likely forecast without DSM.

5/ The MW shown represent cumulative load management capability plus incremental conservation. They are not included in total additional resources but reduce the peak load upon which Reserve Margin calculations are based.

6/ Margin (%) Before Maintenance = Col (10) / Col (9)

7/ Margin (%) After Maintenance = Col (13) / Col (9)

**Schedule 8
Planned And Prospective Generating Facility Additions And Changes**

(1)	(2)	(3)	(4)	(5)	(6)	(7)	(8)	(9)	(10)	(11)	(12)	(13)	(14)	(15)
Plant Name	Unit No	Location	Unit Type	Fuel		Fuel Transport		Const Start Mo /Yr	Comm In-Service Mo /Yr	Expected Retirement Mo /Yr	Gen Max Nameplate KW	Net Capability		Status
				Pri	Alt	Pri	All					Winter MW	Summer MW	
<u>ADDITIONS</u>														
<u>2001</u>														
Martin Combustion Turbines	8A	Martin County 29/29S/38E	CT	NG	FO2	PL	PL	Apr-99	Jun-01	Unknown	190,000	---	149	P
Martin Combustion Turbines	8B	Martin County 29/29S/38E	CT	NG	FO2	PL	PL	Apr-99	Jun-01	Unknown	190,000	---	149	P
2001 Total:												0	298	
<u>2002</u>														
Martin Combustion Turbines	8A	Martin County 29/29S/38E	CT	NG	FO2	PL	PL	Apr-99	Jun-01	Unknown	190,000	181	---	P
Martin Combustion Turbines	8B	Martin County 29/29S/38E	CT	NG	FO2	PL	PL	Apr-99	Jun-01	Unknown	190,000	181	---	P
2002 Total:												362	---	
<u>2003</u>														
Fort Myers Combustion Turbines	13	Lee County 35/43S/25E	CT	NG	FO2	PL	PL	Apr-02	Apr-03	Unknown	190,000	---	149	P
Fort Myers Combustion Turbines	14	Lee County 35/43S/25E	CT	NG	FO2	PL	PL	Apr-02	May-03	Unknown	190,000	---	149	P
2003 Total:												---	298	
<u>2004</u>														
Fort Myers Combustion Turbines	13	Lee County 35/43S/25E	CT	NG	FO2	PL	PL	Apr-02	Apr-03	Unknown	190,000	181	---	P
Fort Myers Combustion Turbines	14	Lee County 35/43S/25E	CT	NG	FO2	PL	PL	Apr-02	May-03	Unknown	190,000	181	---	P
2004 Total:												362	---	
<u>2005</u>														
Martin Combined Cycle Unit	5	Martin County 29/29S/38E	CC	NG	FO2	PL	PL	Jun-02	Jun-05	Unknown	470,000	---	547	P
Midway Combined Cycle Unit	1	St Lucie County 2/36S/39E	CC	NG	FO2	PL	PL	Jun-02	Jun-05	Unknown	470,000	---	547	P
2005 Total:												---	1094	

Schedule 8
Planned And Prospective Generating Facility Additions And Changes

(1)	(2)	(3)	(4)	(5)	(6)	(7)	(8)	(9)	(10)	(11)	(12)	(13)	(14)	(15)
Plant Name	Unit No	Location	Unit Type	Fuel		Fuel Transport		Const Start Mo/Yr	Comm In-Service Mo/Yr	Expected Retirement Mo/Yr	Gen Max Nameplate KW	Net Capability		Status
				Pri	Alt	Pri	Alt					Winter MW	Summer MW	
<u>ADDITIONS</u>														
<u>2006</u>														
Martin Combined		Martin County												
Cycle Unit	5	29/29S/38E	CC	NG	FO2	PL	PL	Jun-02	Jun-05	Unknown	470,000	596	---	P
Midway Combined		St Lucie County												
Cycle Unit	1	2/36S/39E	CC	NG	FO2	PL	PL	Jun-02	Jun-05	Unknown	470,000	596	---	P
Martin Combined		Martin County												
Cycle Unit	6	29/29S/38E	CC	NG	FO2	PL	PL	Jun-03	Jun-06	Unknown	470,000	---	547	P
2006 Total:												1192	547	
<u>2007</u>														
Martin Combined		Martin County												
Cycle Unit	6	29/29S/38E	CC	NG	FO2	PL	PL	Jun-03	Jun-06	Unknown	470,000	596	---	P
Unsitd Combined														
Cycle Unit #1	1	Unknown	CC	NG	FO2	PL	PL	Jun-04	Jun-07	Unknown	470,000	---	547	P
2007 Total:												596	547	
<u>2008</u>														
Unsitd Combined														
Cycle Unit #1	1	Unknown	CC	NG	FO2	PL	PL	Jun-04	Jun-07	Unknown	470,000	596	---	P
2008 Total:												596	0	
<u>2009</u>														
Unsitd Combined														
Cycle Unit #2	2	Unknown	CC	NG	FO2	PL	PL	Jun-06	Jun-09	Unknown	470,000	---	547	P
2009 Total:												0	547	
<u>2010</u>														
Unsitd Combined														
Cycle Unit #2	2	Unknown	CC	NG	FO2	PL	PL	Jun-06	Jun-09	Unknown	470,000	596	---	P
Unsitd Combined														
Cycle Unit #3	3	Unknown	CC	NG	FO2	PL	PL	Jun-07	Jun-10	Unknown	470,000	---	547	P
Unsitd Combined														
Cycle Unit #4	4	Unknown	CC	NG	FO2	PL	PL	Jun-07	Jun-10	Unknown	470,000	---	547	P
Unsitd Combined														
Cycle Unit #5	5	Unknown	CC	NG	FO2	PL	PL	Jun-07	Jun-10	Unknown	470,000	---	547	P
2010 Total:												596	1641	

**Schedule 8
Planned And Prospective Generating Facility Additions And Changes (Cont.)**

(1)	(2)	(3)	(4)	(5)	(6)	(7)	(8)	(9)	(10)	(11)	(12)	(13)	(14)	(15)
Plant Name	Unit No	Location	Unit Type	Fuel		Fuel Transport		Const Start Mo /Yr	Comm In-Service Mo /Yr	Expected Retirement Mo /Yr	Gen Max Nameplate KW	Net Capability		Status
				Pri	Alt	Pri	Alt					Winter ^{1,2)} MW	Summer ^{1, 2)} MW	
CHANGES/UPGRADES														
2001														
Martin	1	Martin County	ST	NG	FO6	PL	PL	N/A	May-01	Unknown	863,000	0	(30)	OT
Martin	2	Martin County	ST	NG	FO6	PL	PL	N/A	May-01	Unknown	863,000	0	(20)	OT
Martin	3	Martin County	CC	NG	FO2	PL	PL	N/A	May-01	Unknown	612,000	0	(7)	OT
Martin	4	Martin County	CC	NG	FO2	PL	PL	N/A	May-01	Unknown	612,000	0	(7)	OT
Cape Canaveral	2	Brevard County	ST	FO6	NG	WA	PL	Nov-00	Nov-00	Unknown	402,050	8	8	OT
Ft Myers Repowering Initial Phase	1 & 2	Lee County	CC	NG	No	PL	No	Nov-00	Jan-01	Unknown	161,700	543	894	RP,U
2001 Total:												551	838	
2002														
Sanford Repowering Initial Phase	4	Volusia County	ST	FO6	NG	WA	PL	Jan-00	N/A	Unknown	106,600	0	(390) ³⁾	RP
Sanford Repowering Initial Phase	5	Volusia County	ST	FO6	NG	WA	PL	Jan-00	N/A	Unknown	106,600	(394) ³⁾	0	RP
Sanford Repowering Second Phase	5	Volusia County	CC	NG	No	PL	No	N/A	Jul-02	Unknown	106,600	0	567	RP
Fort Myers Repowering Second Phase	1 & 2	Lee County	CC	NG	No	PL	No	Sep-01	Jan-02	Unknown	161,700	(1)	35	RP,U
2002 Total:												(395)	212	
2003														
Sanford Repowering Second Phase	4	Volusia County	CC	NG	No	PL	No	N/A	Dec-02	Unknown	106,600	671	957	RP
Sanford Repowering Second Phase	5	Volusia County	CC	NG	No	PL	No	N/A	Jul-02	Unknown	106,600	1,065	0	RP
Fort Myers Repowering Second Phase	1 & 2	Lee County	CC	NG	No	PL	No	Sep-01	Jun-02	Unknown	161,700	531	0	RP,U
2003 Total:												2,267	957	
2004														
2004 Total:												0	0	
2005														
Martin Combustion Turbine Conversion	8A	Martin County	CT	NG	FO2	PL	PL	Jan-04	Jun-05	Unknown	190,000	---	124.5	P
Martin Combustion Turbine Conversion	8B	Martin County	CT	NG	FO2	PL	PL	Jan-04	Jun-05	Unknown	190,000	---	124.5	P
Fort Myers Combustion Turbine Conversion	13	Lee County	CT	NG	FO2	PL	PL	Jan-04	Jun-05	Unknown	190,000	---	124.5	P
Fort Myers Combustion Turbine Conversion	14	Lee County	CT	NG	FO2	PL	PL	Jan-04	Jun-05	Unknown	190,000	---	124.5	P
2005 Total:												0	498	

1)The Winter Total MW value consists of all generation additions and changes achieved by January. The Summer Total MW value consists of all generation additions and changes achieved by July. All other MW will be picked up in the following year. This is done for reserve margin calculation.

2) All MW differences are calculated based on using IRP 2000 Submittal (for the year 2000) as the base for all other years.

3) Negative values for Sanford and Ft. Myers reflect the existing steam units being temporarily out of service during that seasonal period for repowering efforts.

**Schedule 8
Planned And Prospective Generating Facility Additions And Changes (Cont.)**

(1)	(2)	(3)	(4)	(5)	(6)	(7)	(8)	(9)	(10)	(11)	(12)	(13)	(14)	(15)	
Plant Name	Unit No	Location	Unit Type	Fuel		Fuel Transport		Const Start Mo /Yr	Comm In-Service Mo /Yr	Expected Retirement Mo /Yr	Gen Max Nameplate KW	Net Capability		Status	
				Pri	All	Pri	All					Winter ¹⁾ MW	Summer ¹⁾ MW		
<u>CHANGES/UPGRADES</u>															
<u>2006</u>															
Martin Combustion		Martin County													
Turbine Conversion	8A	29/29S/38E	CT	NG	FO2	PL	PL	Jan-04	Jun-05	Unknown	190,000	117.0	---	P	
Martin Combustion		Martin County													
Turbine Conversion	8B	29/29S/38E	CT	NG	FO2	PL	PL	Jan-04	Jun-05	Unknown	190,000	117.0	---	P	
Fort Myers Combustion		Lee County													
Turbine Conversion	13	35/43S/25E	CT	NG	FO2	PL	PL	Jan-04	Jun-05	Unknown	190,000	117.0	---	P	
Fort Myers Combustion		Lee County													
Turbine Conversion	14	35/43S/25E	CT	NG	FO2	PL	PL	Jan-04	Jun-05	Unknown	190,000	117.0	---	P	
												2006 Total:	468	0	
<u>2007</u>															
												2007 Total:	0	0	
<u>2008</u>															
												2008 Total:	0	0	
<u>2009</u>															
												2009 Total:	0	0	
<u>2010</u>															
												2010 Total:	0	0	

1)The Winter Total MW value consists of all generation additions and changes achieved by January. The Summer Total MW value consists of all generation additions and changes achieved by July. All other MW will be picked up in the following year. This is done for reserve margin calculation.

Schedule 9**Status Report and Specifications of Proposed Generating Facilities**

- (1) **Plant Name and Unit Number:** Martin Combustion Turbines No. 8A and No. 8B *
- (2) **Capacity**
a Summer 149 MW
b. Winter 181 MW
- (3) **Technology Type:** Combustion Turbine
- (4) **Anticipated Construction Timing**
a. Field construction start-date: 1999
b. Commercial In-service date: 2001
- (5) **Fuel**
a. Primary Fuel Natural Gas
b. Alternate Fuel Distillate
- (6) **Air Pollution and Control Strategy:** Dry Low Nox Combustors, Natural Gas, 0.05% S. Distillate, & Water Injection on Distillate
- (7) **Cooling Method:** Air Coolers
- (8) **Total Site Area:** 11,300 Acres
- (9) **Construction Status:** P (Planned)
- (10) **Certification Status:** P (Planned)
- (11) **Status with Federal Agencies:** P (Planned)
- (12) **Projected Unit Performance Data:**
Planned Outage Factor (POF): 1%
Forced Outage Factor (FOF): 1%
Equivalent Availability Factor (EAF): 98%
Resulting Capacity Factor (%): Approx. 10% (First Year)
Average Net Operating Heat Rate (ANHOR): 10,430 Btu/kWh
- (13) **Projected Unit Financial Data **,*****
Book Life (Years): 25 years
Total Installed Cost (In-Service Year \$/kW): 477.98
Direct Construction Cost (\$/kW): 449.20
AFUDC Amount (\$/kW): 29.30
Escalation (\$/kW): -0.53
Fixed O&M (\$/kW -Yr.): 0.68
Variable O&M (\$/MWH): 0.86
K Factor: 1.5134

* Values shown are per unit values for the two units being added.

** \$/KW values are based on Summer capacity.

*** Fixed O&M includes capital replacement.

Schedule 9
Status Report and Specifications of Proposed Generating Facilities

- (1) **Plant Name and Unit Number:** Fort Myers Repowering
- (2) **Capacity**
a. Summer 929 MW Incremental (1473 MW Total After Repowering)
b. Winter 1,073 MW Incremental (1617 MW Total After Repowering)
- (3) **Technology Type:** Combined Cycle
- (4) **Anticipated Construction Timing**
a. Field construction start-date: 2000
b. Commercial In-service date: 2002
- (5) **Fuel**
a. Primary Fuel Natural Gas
b. Alternate Fuel None
- (6) **Air Pollution and Control Strategy:** Dry Low Nox Combustors, Natural Gas
- (7) **Cooling Method:** Once-through Cooling
- (8) **Total Site Area:** 460 Acres
- (9) **Construction Status:** P (Planned)
- (10) **Certification Status:** P (Planned)
- (11) **Status with Federal Agencies:** P (Planned)
- (12) **Projected Unit Performance Data:**
Planned Outage Factor (POF): 3%
Forced Outage Factor (FOF): 1%
Equivalent Availability Factor (EAF): 96%
Resulting Capacity Factor (%): 96% (First Year)
Average Net Operating Heat Rate (ANHOR): 6,830 Btu/kWh
- (13) **Projected Unit Financial Data, *,**,*****
Book Life (Years): 25 years
Total Installed Cost (In-Service Year \$/kW): 655.96
Direct Construction Cost (\$/kW): 560.71
AFUDC Amount (\$/kW): 94.59
Escalation (\$/kW): 0.66
Fixed O&M (\$/kW -Yr.): 13.30
Variable O&M (\$/MWH): 0.37
K Factor: 1.5419

* \$/kW values are based on incremental Summer capacity.

** Note that cost values shown do not reflect the FPL system benefits which result from efficiency improvements to the existing steam capacity at the site.

*** Fixed O&M includes capital replacement.

Schedule 9
Status Report and Specifications of Proposed Generating Facilities

- (1) **Plant Name and Unit Number:** Sanford Unit 4 Repowering
- (2) **Capacity**
a. Summer 567 MW Incremental (957 MW Total After Repowering)
b. Winter 671 MW Incremental (1065 MW Total After Repowering)
- (3) **Technology Type:** Combined Cycle
- (4) **Anticipated Construction Timing**
a. Field construction start-date: 2000
b. Commercial In-service date: 2002
- (5) **Fuel**
a. Primary Fuel Natural Gas
b. Alternate Fuel None
- (6) **Air Pollution and Control Strategy:** Dry Low Nox Combustors and Natural Gas
- (7) **Cooling Method:** Cooling Pond
- (8) **Total Site Area:** 1,718 Acres
- (9) **Construction Status:** P (Planned)
- (10) **Certification Status:** P (Planned)
- (11) **Status with Federal Agencies:** P (Planned)
- (12) **Projected Unit Performance Data:**
Planned Outage Factor (POF): 3%
Forced Outage Factor (FOF): 1%
Equivalent Availability Factor (EAF): 96%
Resulting Capacity Factor (%): 96% (First Year)
Average Net Operating Heat Rate (ANHOR): 6,860 Btu/kWh
- (13) **Projected Unit Financial Data *,**,*****
Book Life (Years): 25 years
Total Installed Cost (In-Service Year \$/kW): 708.12
Direct Construction Cost (\$/kW): 595.11
AFUDC Amount (\$/kW): 112.45
Escalation (\$/kW): 0.56
Fixed O&M (\$/kW -Yr.): 14.25
Variable O&M (\$/MWH): 0.37
K Factor: 1.4701

* \$/kW values are based on incremental Summer capacity.

** Note that cost values shown do not reflect the FPL system benefits which result from efficiency improvements to the existing steam capacity at the site.

*** Fixed O&M includes capital replacement.

Schedule 9
Status Report and Specifications of Proposed Generating Facilities

- (1) **Plant Name and Unit Number:** Sanford Unit 5 Repowering
- (2) **Capacity**
a. Summer 567 MW Incremental (957 MW Total After Repowering)
b. Winter 671 MW Incremental (1065 MW Total After Repowering)
- (3) **Technology Type:** Combined Cycle
- (4) **Anticipated Construction Timing**
a. Field construction start-date: 2000
b. Commercial In-service date: 2002
- (5) **Fuel**
a. Primary Fuel Natural Gas
b. Alternate Fuel Distillate
- (6) **Air Pollution and Control Strategy:** Dry Low Nox Combustors, Natural Gas, 0.05% S Distillate, & Water Injection on Distillate
- (7) **Cooling Method:** Cooling Pond
- (8) **Total Site Area:** 1,718 Acres
- (9) **Construction Status:** P (Planned)
- (10) **Certification Status:** P (Planned)
- (11) **Status with Federal Agencies:** P (Planned)
- (12) **Projected Unit Performance Data:**
Planned Outage Factor (POF): 3%
Forced Outage Factor (FOF): 1%
Equivalent Availability Factor (EAF): 96%
Resulting Capacity Factor (%): 96% (First Year)
Average Net Operating Heat Rate (ANHOR): 6,860 Btu/kWh
- (13) **Projected Unit Financial Data *,**,*****
Book Life (Years): 25 years
Total Installed Cost (In-Service Year \$/kW): 678.08
Direct Construction Cost (\$/kW): 595.11
AFUDC Amount (\$/kW): 82.41
Escalation (\$/kW): 0.56
Fixed O&M (\$/kW -Yr.): 14.25
Variable O&M (\$/MWH): 0.37
K Factor: 1.5341

* \$/kW values are based on incremental Summer capacity.

** Note that cost values shown do not reflect the FPL system benefits which result from efficiency improvements to the existing steam capacity at the site.

*** Fixed O&M includes capital replacement.

Schedule 9
Status Report and Specifications of Proposed Generating Facilities

- (1) **Plant Name and Unit Number:** Fort Myers Combustion Turbines No. 13 and No. 14 *
- (2) **Capacity**
a. Summer 149 MW
b. Winter 181 MW
- (3) **Technology Type:** Combustion Turbine
- (4) **Anticipated Construction Timing**
a. Field construction start-date: 2002
b. Commercial In-service date: 2003
- (5) **Fuel**
a. Primary Fuel Natural Gas
b. Alternate Fuel Distillate
- (6) **Air Pollution and Control Strategy:** Dry Low Nox Combustors, Natural Gas, 0.05% S. Distillate, & Water Injection on Distillate
- (7) **Cooling Method:** Air Coolers
- (8) **Total Site Area:** 460 Acres
- (9) **Construction Status:** P (Planned)
- (10) **Certification Status:** P (Planned)
- (11) **Status with Federal Agencies:** P (Planned)
- (12) **Projected Unit Performance Data:**
Planned Outage Factor (POF): 1%
Forced Outage Factor (FOF): 1%
Equivalent Availability Factor (EAF): 98%
Resulting Capacity Factor (%): Approx. 10% (First Year)
Average Net Operating Heat Rate (ANHOR): 10,430 Btu/kWh
- (13) **Projected Unit Financial Data **,*****
Book Life (Years): 25 years
Total Installed Cost (In-Service Year \$/kW): 542.80
Direct Construction Cost (\$/kW): 509.94
AFUDC Amount (\$/kW): 31.30
Escalation (\$/kW): 1.56
Fixed O&M (\$/kW -Yr.): 0.68
Variable O&M (\$/MWH): 0.86
K Factor: 1.5247

* Values shown are per unit values for the two units being added.

** \$/KW values are based on Summer capacity.

*** Fixed O&M includes capital replacement.

Schedule 9
Status Report and Specifications of Proposed Generating Facilities

- (1) **Plant Name and Unit Number:** Martin No. 5
- (2) **Capacity**
a. Summer 547 MW
b. Winter 596 MW
- (3) **Technology Type:** Combined Cycle
- (4) **Anticipated Construction Timing**
a. Field construction start-date: 2002
b. Commercial In-service date: 2005
- (5) **Fuel**
a. Primary Fuel Natural Gas
b. Alternate Fuel Distillate
- (6) **Air Pollution and Control Strategy:** Dry Low Nox Combustors, Natural Gas, 0.05% S Distillate, & Water Injection on Distillate
- (7) **Cooling Method:** Cooling Pond
- (8) **Total Site Area:** 11,300 Acres
- (9) **Construction Status:** P (Planned)
- (10) **Certification Status:** P (Planned)
- (11) **Status with Federal Agencies:** P (Planned)
- (12) **Projected Unit Performance Data:**
Planned Outage Factor (POF): 3%
Forced Outage Factor (FOF): 1%
Equivalent Availability Factor (EAF): 96%
Resulting Capacity Factor (%): 96% (First Year)
Average Net Operating Heat Rate (ANHOR): 7,150 Btu/kWh
- (13) **Projected Unit Financial Data *,****
Book Life (Years): 25 years
Total Installed Cost (In-Service Year \$/kW): 503.31
Direct Construction Cost (\$/kW): 411.88
AFUDC Amount (\$/kW): 82.95
Escalation (\$/kW): 8.48
Fixed O&M (\$/kW -Yr.): 9.30
Variable O&M (\$/MWH): 0.74
K Factor: 1.5489

* \$/KW values are based on Summer capacity.

** Fixed O&M includes capital replacement.

Schedule 9
Status Report and Specifications of Proposed Generating Facilities

- (1) **Plant Name and Unit Number:** Martin Combustion Turbine Conversion
- (2) **Capacity**
a. Summer 249 MW
b. Winter 234 MW
- (3) **Technology Type:** Combined Cycle
- (4) **Anticipated Construction Timing**
a. Field construction start-date: 2004
b. Commercial In-service date: 2005
- (5) **Fuel**
a. Primary Fuel Natural Gas
b. Alternate Fuel Distillate
- (6) **Air Pollution and Control Strategy:** Dry Low Nox Combustors, Natural Gas, 0.05% S Distillate, & Water Injection on Distillate
- (7) **Cooling Method:** Cooling Pond
- (8) **Total Site Area:** 11,300 Acres
- (9) **Construction Status:** P (Planned)
- (10) **Certification Status:** P (Planned)
- (11) **Status with Federal Agencies:** P (Planned)
- (12) **Projected Unit Performance Data ***
Planned Outage Factor (POF): 3%
Forced Outage Factor (FOF): 1%
Equivalent Availability Factor (EAF): 96%
Resulting Capacity Factor (%): 96% (First Year)
Average Net Operating Heat Rate (ANHOR): 7,150 Btu/kWh
- (13) **Projected Unit Financial Data **,*****
Book Life (Years): 25 years
Total Installed Cost (In-Service Year \$/kW): 481.36
Direct Construction Cost (\$/kW): 433.91
AFUDC Amount (\$/kW): 31.29
Escalation (\$/kW): 16.16
Fixed O&M (\$/kW -Yr.): 9.30 *
Variable O&M (\$/MWH): 0.74 *
K Factor: 1.5147

* Values represent an operational combined cycle unit after the conversion is completed.

** \$/KW values are based on Summer incremental capacity.

*** Fixed O&M cost includes capital replacement.

Schedule 9
Status Report and Specifications of Proposed Generating Facilities

- (1) **Plant Name and Unit Number:** Fort Myers Combustion Turbine Conversion
- (2) **Capacity**
a. Summer 249 MW
b. Winter 234 MW
- (3) **Technology Type:** Combined Cycle
- (4) **Anticipated Construction Timing**
a. Field construction start-date: 2004
b. Commercial In-service date: 2005
- (5) **Fuel**
a. Primary Fuel Natural Gas
b. Alternate Fuel Distillate
- (6) **Air Pollution and Control Strategy:** Dry Low Nox Combustors, Natural Gas, 0.05% S. Distillate, & Water Injection on Distillate
- (7) **Cooling Method:** Cooling Tower
- (8) **Total Site Area:** 460 Acres
- (9) **Construction Status:** P (Planned)
- (10) **Certification Status:** P (Planned)
- (11) **Status with Federal Agencies:** P (Planned)
- (12) **Projected Unit Performance Data ***
Planned Outage Factor (POF): 3%
Forced Outage Factor (FOF): 1%
Equivalent Availability Factor (EAF): 96%
Resulting Capacity Factor (%): 96% (First Year)
Average Net Operating Heat Rate (ANHOR): 7,150 Btu/kWh
- (13) **Projected Unit Financial Data **,*****
Book Life (Years): 25 years
Total Installed Cost (In-Service Year \$/kW): 481.36
Direct Construction Cost (\$/kW): 433.91
AFUDC Amount (\$/kW): 31.29
Escalation (\$/kW): 16.16
Fixed O&M (\$/kW -Yr.): 9.30 *
Variable O&M (\$/MWH): 0.74 *
K Factor: 1.5147

* Values represent an operational combined cycle unit after the conversion is completed.

** \$/KW values are based on Summer incremental capacity.

*** Fixed O&M cost includes capital replacement.

Schedule 9
Status Report and Specifications of Proposed Generating Facilities

- (1) **Plant Name and Unit Number:** Midway Combined Cycle
- (2) **Capacity**
a. Summer 547 MW
b. Winter 596 MW
- (3) **Technology Type:** Combined Cycle
- (4) **Anticipated Construction Timing**
a. Field construction start-date: 2002
b. Commercial In-service date: 2005
- (5) **Fuel**
a. Primary Fuel Natural Gas
b. Alternate Fuel Distillate
- (6) **Air Pollution and Control Strategy:** Dry Low Nox Combustors, Natural Gas, 0.05% S. Distillate, & Water Injection on Distillate
- (7) **Cooling Method:** Grey water or groundwater
- (8) **Total Site Area:** 122 Acres
- (9) **Construction Status:** P (Planned)
- (10) **Certification Status:** P (Planned)
- (11) **Status with Federal Agencies:** P (Planned)
- (12) **Projected Unit Performance Data:**
Planned Outage Factor (POF): 3%
Forced Outage Factor (FOF): 1%
Equivalent Availability Factor (EAF): 96%
Resulting Capacity Factor (%): 96% (First Year)
Average Net Operating Heat Rate (ANHOR): 7,150 Btu/kWh
- (13) **Projected Unit Financial Data *,****
Book Life (Years): 25 years
Total Installed Cost (In-Service Year \$/kW): 439.57
Direct Construction Cost (\$/kW): 362.93
AFUDC Amount (\$/kW): 68.27
Escalation (\$/kW): 8.37
Fixed O&M (\$/kW -Yr.): 9.30
Variable O&M (\$/MWH): 0.74
K Factor: 1.5457

* \$/KW values are based on Summer capacity.

** Fixed O&M cost includes capital replacement.

Schedule 9
Status Report and Specifications of Proposed Generating Facilities

- (1) **Plant Name and Unit Number:** Martin No 6
- (2) **Capacity**
a. Summer 547 MW
b. Winter 596 MW
- (3) **Technology Type:** Combined Cycle
- (4) **Anticipated Construction Timing**
a. Field construction start-date: 2003
b. Commercial In-service date: 2006
- (5) **Fuel**
a. Primary Fuel Natural Gas
b. Alternate Fuel Distillate
- (6) **Air Pollution and Control Strategy:** Dry Low Nox Combustors, Natural Gas, 0.05% S Distillate, & Water Injection on Distillate
- (7) **Cooling Method:** Cooling Pond
- (8) **Total Site Area:** 11,300 Acres
- (9) **Construction Status:** P (Planned)
- (10) **Certification Status:** P (Planned)
- (11) **Status with Federal Agencies:** P (Planned)
- (12) **Projected Unit Performance Data:**
Planned Outage Factor (POF): 3%
Forced Outage Factor (FOF): 1%
Equivalent Availability Factor (EAF): 96%
Resulting Capacity Factor (%): 96% (First Year)
Average Net Operating Heat Rate (ANHOR): 7,150 Btu/kWh
- (13) **Projected Unit Financial Data *,****
Book Life (Years): 25 years
Total Installed Cost (In-Service Year \$/kW): 454.41
Direct Construction Cost (\$/kW): 367.96
AFUDC Amount (\$/kW): 71.07
Escalation (\$/kW): 15.38
Fixed O&M (\$/kW -Yr.): 9.30
Variable O&M (\$/MWH): 0.74
K Factor: 1.5460

* \$/KW values are based on Summer capacity.

** Fixed O&M cost includes capital replacement.

Schedule 9
Status Report and Specifications of Proposed Generating Facilities

- (1) **Plant Name and Unit Number:** Unsited Combined Cycle No. 1
- (2) **Capacity**
a. Summer 547 MW
b. Winter 596 MW
- (3) **Technology Type:** Combined Cycle
- (4) **Anticipated Construction Timing**
a. Field construction start-date: 2004
b. Commercial In-service date: 2007
- (5) **Fuel**
a. Primary Fuel Natural Gas
b. Alternate Fuel Distillate
- (6) **Air Pollution and Control Strategy:** Dry Low Nox Combustors, Natural Gas, 0.05% S. Distillate, & Water Injection on Distillate
- (7) **Cooling Method:** Unknown
- (8) **Total Site Area:** Unknown Acres
- (9) **Construction Status:** P (Planned)
- (10) **Certification Status:** P (Planned)
- (11) **Status with Federal Agencies:** P (Planned)
- (12) **Projected Unit Performance Data:**
Planned Outage Factor (POF): 3%
Forced Outage Factor (FOF): 1%
Equivalent Availability Factor (EAF): 96%
Resulting Capacity Factor (%): 96% (First Year)
Average Net Operating Heat Rate (ANHOR): 7,150 Btu/kWh
- (13) **Projected Unit Financial Data *,****
Book Life (Years): 25 years
Total Installed Cost (In-Service Year \$/kW): 532.83
Direct Construction Cost (\$/kW): 419.24
AFUDC Amount (\$/kW): 85.38
Escalation (\$/kW): 28.21
Fixed O&M (\$/kW -Yr.): 12.10
Variable O&M (\$/MWH): 0.74
K Factor: 1.5473

* \$/KW values are based on Summer capacity.

** Fixed O&M cost includes capital replacement.

Schedule 9
Status Report and Specifications of Proposed Generating Facilities

- (1) **Plant Name and Unit Number:** Unsited Combined Cycle No. 2
- (2) **Capacity**
a. Summer 547 MW
b. Winter 596 MW
- (3) **Technology Type:** Combined Cycle
- (4) **Anticipated Construction Timing**
a. Field construction start-date: 2006
b. Commercial In-service date: 2009
- (5) **Fuel**
a. Primary Fuel Natural Gas
b. Alternate Fuel Distillate
- (6) **Air Pollution and Control Strategy:** Dry Low Nox Combustors, Natural Gas, 0.05% S. Distillate, & Water Injection on Distillate
- (7) **Cooling Method:** Unknown
- (8) **Total Site Area:** Unknown Acres
- (9) **Construction Status:** P (Planned)
- (10) **Certification Status:** P (Planned)
- (11) **Status with Federal Agencies:** P (Planned)
- (12) **Projected Unit Performance Data:**
Planned Outage Factor (POF): 3%
Forced Outage Factor (FOF): 1%
Equivalent Availability Factor (EAF): 96%
Resulting Capacity Factor (%): 96% (First Year)
Average Net Operating Heat Rate (ANHOR): 7,150 Btu/kWh
- (13) **Projected Unit Financial Data *,****
Book Life (Years): 25 years
Total Installed Cost (In-Service Year \$/kW): 554.71
Direct Construction Cost (\$/kW): 419.24
AFUDC Amount (\$/kW): 88.86
Escalation (\$/kW): 46.61
Fixed O&M (\$/kW -Yr.): 12.10
Variable O&M (\$/MWH): 0.74
K Factor: 1.5473

* \$/KW values are based on Summer capacity.

** Fixed O&M cost includes capital replacement.

Schedule 9
Status Report and Specifications of Proposed Generating Facilities

- (1) **Plant Name and Unit Number:** Unsited Combined Cycle No. 3, No. 4, and No 5 *
- (2) **Capacity**
a. Summer 547 MW
b. Winter 596 MW
- (3) **Technology Type:** Combined Cycle
- (4) **Anticipated Construction Timing**
a. Field construction start-date: 2007
b. Commercial In-service date 2010
- (5) **Fuel**
a. Primary Fuel Natural Gas
b. Alternate Fuel Distillate
- (6) **Air Pollution and Control Strategy:** Dry Low Nox Combustors, Natural Gas, 0.05% S. Distillate, & Water Injection on Distillate
- (7) **Cooling Method:** Unknown
- (8) **Total Site Area:** Unknown Acres
- (9) **Construction Status:** P (Planned)
- (10) **Certification Status:** P (Planned)
- (11) **Status with Federal Agencies:** P (Planned)
- (12) **Projected Unit Performance Data:**
Planned Outage Factor (POF): 3%
Forced Outage Factor (FOF): 1%
Equivalent Availability Factor (EAF): 96%
Resulting Capacity Factor (%): 96% (First Year)
Average Net Operating Heat Rate (ANHOR): 7,150 Btu/kWh
- (13) **Projected Unit Financial Data **,*****
Book Life (Years): 25 years
Total Installed Cost (In-Service Year \$/kW): 566.41
Direct Construction Cost (\$/kW): 419.24
AFUDC Amount (\$/kW): 90.72
Escalation (\$/kW): 56.45
Fixed O&M (\$/kW -Yr.): 12.10
Variable O&M (\$/MWH): 0.74
K Factor: 1.5473

* Values shown are per unit values for the three units being added.

** \$/KW values are based on Summer capacity.

*** Fixed O&M cost includes capital replacement.

Schedule 10
Status Report and Specifications of Proposed Integrated Transmission Lines

Martin: 2 CT's

- | | | |
|-----|-------------------------------------|--|
| (1) | Point of Origin and Termination: | Not Applicable |
| (2) | Number of Lines: | Not Applicable |
| (3) | Right-of-way | FPL Owned |
| (4) | Line Length: | Not Applicable |
| (5) | Voltage. | Not Applicable |
| (6) | Anticipated Construction Timing: | Start date: Not Applicable
End date: Not Applicable |
| (7) | Anticipated Capital Investment: | Not Applicable |
| (8) | Substations: | Not Applicable |
| (9) | Participation with Other Utilities: | None |

Schedule 10
Status Report and Specifications of Proposed Integrated Transmission Lines

Ft. Myers Repowering

- | | | |
|-----|-------------------------------------|--|
| (1) | Point of Origin and Termination: | From Ft. Myers – To Calusa |
| (2) | Number of Lines: | 1 |
| (3) | Right-of-way | FPL Owned |
| (4) | Line Length: | 1.58 miles |
| (5) | Voltage: | 230 kV |
| (6) | Anticipated Construction Timing: | Start date: May 1, 2000
End date: April 1, 2001 |
| (7) | Anticipated Capital Investment: | \$354,000 |
| (8) | Substations: | Ft. Myers and Calusa |
| (9) | Participation with Other Utilities: | None |

- | | | |
|-----|-------------------------------------|--|
| (1) | Point of Origin and Termination: | From Ft. Myers – To Orange River |
| (2) | Number of Lines: | 1 |
| (3) | Right-of-way | FPL Owned |
| (4) | Line Length: | 2.57 miles |
| (5) | Voltage: | 230 kV |
| (6) | Anticipated Construction Timing: | Start date: March 1, 2000
End date: October 1, 2000 |
| (7) | Anticipated Capital Investment: | \$706,750 |
| (8) | Substations: | Ft. Myers and Orange River |
| (9) | Participation with Other Utilities: | None |

Schedule 10
Status Report and Specifications of Proposed Integrated Transmission Lines

Sanford Repowering

- | | | |
|-----|-------------------------------------|---|
| (1) | Point of Origin and Termination: | From Sanford – To Poinsett |
| (2) | Number of Lines: | 2 |
| (3) | Right-of-way | FPL Owned |
| (4) | Line Length: | 45 miles |
| (5) | Voltage: | 230 kV |
| (6) | Anticipated Construction Timing: | Start date: January 1, 2001
End date: June 1, 2001 |
| (7) | Anticipated Capital Investment: | \$20,360,000 |
| (8) | Substations: | Sanford and Poinsett |
| (9) | Participation with Other Utilities: | None |

Schedule 10
Status Report and Specifications of Proposed Integrated Transmission Lines

Ft. Myers: 2 CT's

- | | | |
|-----|-------------------------------------|--|
| (1) | Point of Origin and Termination: | From Ft. Myers GT Collector bus – To Orange River |
| (2) | Number of Lines: | 1 |
| (3) | Right-of-way | FPL Owned |
| (4) | Line Length: | 2.5 miles |
| (5) | Voltage: | 230 kV |
| (6) | Anticipated Construction Timing: | Start date: January 1, 2003
End date: May 1, 2003 |
| (7) | Anticipated Capital Investment: | \$1,050,000 |
| (8) | Substations: | Orange River and Ft. Myers GT collector bus |
| (9) | Participation with Other Utilities: | None |

Schedule 10
Status Report and Specifications of Proposed Integrated Transmission Lines

Martin 5

- | | | |
|-----|-------------------------------------|---|
| (1) | Point of Origin and Termination: | a. From Pratt & Whitney – To Indiantown
b. From Pratt & Whitney – To Ranch
c. From Martin – To Indiantown |
| (2) | Number of Lines: | 3 |
| (3) | Right-of-way | FPL Owned |
| (4) | Line Length: | a. 8.45 miles
b. 20.74 miles
c. 11.8 miles |
| (5) | Voltage: | 230 kV |
| (6) | Anticipated Construction Timing: | Start date: June 1, 2004
End date: June 1, 2005 |
| (7) | Anticipated Capital Investment: | \$6,725,000 |
| (8) | Substations: | Pratt & Whitney, Ranch, Martin, and Indiantown |
| (9) | Participation with Other Utilities: | None |

Note: The existing lines (a & b) will be upgraded to a higher current rating. The line from Martin to Indiantown (c) will be a new circuit integrated with this project.

Schedule 10
Status Report and Specifications of Proposed Integrated Transmission Lines

Martin: Conversion of CT's into a Combined Cycle Unit

- (1) Point of Origin and Termination: Not Available
- (2) Number of Lines: Not Available
- (3) Right-of-way FPL Owned
- (4) Line Length: Not Available
- (5) Voltage: Not Available
- (6) Anticipated Construction Timing: Start date: Not Available
End date: Not Available
- (7) Anticipated Capital Investment: Not Available
- (8) Substations: Not Available
- (9) Participation with Other Utilities: None

Schedule 10
Status Report and Specifications of Proposed Integrated Transmission Lines

Ft. Myers: Conversion of CT's into a Combined Cycle Unit

- | | | |
|-----|-------------------------------------|--|
| (1) | Point of Origin and Termination: | Not Available |
| (2) | Number of Lines: | Not Available |
| (3) | Right-of-way | FPL Owned |
| (4) | Line Length: | Not Available |
| (5) | Voltage: | Not Available |
| (6) | Anticipated Construction Timing: | Start date: Not Available
End date: Not Available |
| (7) | Anticipated Capital Investment: | Not Available |
| (8) | Substations: | Not Available |
| (9) | Participation with Other Utilities: | None |

Schedule 10
Status Report and Specifications of Proposed Integrated Transmission Lines

Midway: Combined Cycle Unit

- | | | |
|-----|-------------------------------------|--|
| (1) | Point of Origin and Termination: | Not Available |
| (2) | Number of Lines: | Not Available |
| (3) | Right-of-way | FPL Owned |
| (4) | Line Length: | Not Available |
| (5) | Voltage: | Not Available |
| (6) | Anticipated Construction Timing: | Start date: Not Available
End date: Not Available |
| (7) | Anticipated Capital Investment: | Not Available |
| (8) | Substations: | Not Available |
| (9) | Participation with Other Utilities: | None |

Schedule 10
Status Report and Specifications of Proposed Integrated Transmission Lines

Martin 6

- | | | |
|-----|-------------------------------------|--|
| (1) | Point of Origin and Termination: | Not Applicable |
| (2) | Number of Lines: | Not Applicable |
| (3) | Right-of-way | FPL Owned |
| (4) | Line Length: | Not Applicable |
| (5) | Voltage: | Not Applicable |
| (6) | Anticipated Construction Timing: | Start date: Not Applicable
End date: Not Applicable |
| (7) | Anticipated Capital Investment: | Not Applicable |
| (8) | Substations: | Not Applicable |
| (9) | Participation with Other Utilities: | None |

(This page is left intentionally blank.)

CHAPTER IV

Environmental and Land Use Information

(This page is left intentionally blank.)

IV. Environmental and Land Use Information

IV.A Protection of the Environment

FPL operates in a sensitive, temperate/sub-tropical environment containing a number of distinct ecosystems with many endangered plant and animal species. Population growth in our service area is continuing, which heightens competition for air, land, and water resources which are necessary to meet the increased demand for generation, transmission, and distribution of electricity. At the same time, residents and tourists want unspoiled natural amenities, and the general public has an expectation that large corporations such as FPL will conduct their business in an environmentally responsible manner.

Over the years FPL has gained national recognition for its commitment to meeting its customers' energy needs in harmony with the environment. For example, in 1983, FPL won the U.S. Department of the Interior's Conservation Service Award and received the Florida Audubon Society's Corporate Service Award in 1986. In 1998, FPL won the U.S. Coast Guard's prestigious William M. Benkert Award for demonstrating "tremendous vision and dedication to excellence in marine environmental protection." FPL's environmental protection commitment is an integral part of how it conducts business and formal corporate policies have been established to protect the environment.

In March, 2000, Innovest, a company that evaluates environmental performance of Fortune 500 companies, ranked FPL number one of 30 electric utilities reviewed. The Innovest report relates environmental performance with overall management performance and suggests that good environmental performance is a predictor of good investment opportunity.

IV.B FPL's Environmental Statement

To reaffirm its commitment to conduct business in an environmentally responsible manner, FPL developed an Environmental Statement in 1992 to clearly define the Company's position. This statement reflects how FPL incorporates environmental values into all aspects of the Company's activities and serves as a framework for new environmental initiatives throughout the Company. The FPL environmental statement further establishes a long-term direction of environmental responsibility for the Company. FPL's Environmental Statement is:

It is the Company's intent to continue to conduct its business in an environmentally responsible manner. Accordingly, Florida Power & Light Company will:

- Comply with the spirit and intent, as well as the letter of, environmental laws, regulations, and standards.
- Incorporate environmental protection and stewardship as an integral part of the design, construction, operation, and maintenance of our facilities.
- Encourage the wise use of energy to minimize the impact on the environment.
- Communicate effectively on environmental issues.
- Conduct periodic self-evaluations, report performance, and take appropriate actions.

IV.C Environmental Management

In order to implement the Environmental Statement, FPL established an environmental management system to direct and control the fulfillment of the organization's environmental responsibilities. A key component of the system is an Environmental Assurance Program which is discussed below. Other components include: written environmental policies and procedures, delineation of organizational responsibilities and individual accountabilities, allocation of appropriate resources for environmental compliance management (which includes reporting and corrective action when non-compliance occurs), environmental incident/emergency response, environmental risk assessment/management, environmental regulatory development and tracking, and environmental management information systems.

IV.D Environmental Assurance Program

FPL's Environmental Assurance Program consists of activities which are designed to: evaluate environmental performance, verify compliance with Company policy as well as with legal and regulatory requirements, and communicate results to corporate management. The principal mechanism for pursuing environmental assurance is the environmental audit. An environmental audit may be defined as a management tool comprising a systematic, documented, periodic, and objective evaluation of the performance of the organization and of the specific management systems and equipment designed to protect the environment. The environmental audit's primary objectives are to: 1) facilitates management control of environmental practices; and, 2) assess compliance with existing environmental regulatory requirements and Company policies.

IV.E Environmental Communication and Facilitation

FPL is involved in many efforts to enhance environmental protection through the facilitation of environmental awareness and public education. Some of FPL's 2000 environmental outreach activities are noted in Table IV.E.1.

2000 FPL Environmental Outreach Activities

Site	Activity	# of Participants (approx.)
St. Lucie Plant	Turtle Beach Nature Trail Visitation	2,020
Riviera Plant & Fort Myers Plant	Manatee Awareness Activities	144,000
St. Lucie Plant	Turtle Walk Participation	725
St. Lucie Plant	FPL Energy Encounter	32,974
Not Applicable	Inquiries – 800 environmental information line and emails	4,500
Martin Plant	Barley Barber Swamp Visitation	3,400

Table IV.E.1

IV.F Preferred And Potential Sites

Based upon its projection of future resource needs, FPL has identified preferred and potential sites for future generation additions. These preferred and potential sites are discussed in separate sections below.

IV.F.1 Preferred Sites

FPL has identified four preferred sites: the existing Fort Myers plant site, the existing Sanford plant site, the existing Martin plant site and the existing Midway substation site. These four sites are currently the expected known locations for the capacity additions, which FPL projects to make during the 2001 – 2006 period. (Other capacity additions, in the form of new combined cycle units, will be made in the 2007 through 2010 time period. Selection of sites for these later capacity additions is not yet needed and has not been made. Please see Table III.B.1).

The four preferred sites are discussed below. FPL has committed to repower existing units at both its Fort Myers and Sanford sites, to first add new combustion turbine (CT), then later convert this CT capacity into combined cycle (CC) capacity at the Martin and Fort Myers sites, and to add new combined cycle (CC) capacity at the Martin and Midway sites.

Preferred Site #1: Fort Myers Plant, Lee County

The site is located on the 460-acre Fort Myers property. Current facilities on the site include two steam electric generating units (nominally 150 MW and 400 MW, respectively), three CT's (which will soon be joined by three more CT's) which, along with heat recovery steam generating (HRSG) units and the existing steam turbines will comprise the repowered facility (construction completion in 2002); and a bank of 12 simple-cycle combustion turbine peaking units. The site has direct access to a four-lane highway, State Road (SR) 80, and barge access is available. The nearest town is Tice, which is approximately 4 miles west of the site. The City of Fort Myers is approximately 8 miles west of the site. The Fort Myers site has been listed as a potential or preferred site in previous FPL Site Plans.

FPL is planning to add new capacity by first adding two CT's, then converting the two CT's into one CC unit. The CT's are expected to be in service in the Spring of 2003 and will add 298 MW (Summer) and 362 MW (Winter) to FPL's system. The conversion to CC configuration is planned to be completed and in - service by mid-2005. The CT - to - CC conversion will add approximately another 249 MW (Summer) and 234 MW (Winter) to FPL's system.

The repowering project currently underway at the site will add approximately 930 MW during Summer conditions and approximately 1,070 MW during Winter conditions. This project is expected to be completed in mid-2002.

The output capability of the existing bank of 12 CT's at the site will be unaffected by the repowering project and the addition of the two new CT's.

a. and b. U.S. geological Survey (USGS) May and Proposed Facilities Layout Map

A USGS map of the Fort Myers plant site, plus a map of the general layout of the proposed generating facilities at the site, are found at the end of this chapter.

c. Map of Site and Adjacent Areas

An overview map of the site and adjacent areas is also found at the end of this chapter. It is pertinent to note that several designations on the current South Florida Water Management District Florida Land Use, Cover, and Forms Classification System (FLUCCS) appear to be in error, or to require some clarification. For example, the freshwater marsh identified toward the western boundary of the site is actually FPL's 50-acre evaporation/percolation pond. Similarly, while there are scattered mangroves along the shore, the "Central Mangrove" area shown is not mangrove but is the FPL switchyard

for that site. The "Improved Pasture" shown towards the east of the site is currently the location of a tree nursery.

d. Existing Land Uses of Site and Adjacent Areas

The land on the site is primarily dedicated to industrial use with surrounding grassy and landscaped areas. There is the previously mentioned 50-acre evaporation/percolation pond on the site. Much of the site is currently being used for either direct construction activities or in support of the repowering project.

FPL has recently donated an 18-acre island, located north of the plant in the Caloosahatchee River, to the United States Fish & Wildlife Service (USFWS) for the purpose of wildlife conservation. This island has been owned by FPL since the 1950's, but has never been developed. The USFWS plans to incorporate the island into the Caloosahatchee National Wildlife Refuge.

Lee County operates Manatee Park (approximately 5 acres) with a manatee viewing area on FPL property to the east side of the discharge canal where it adjoins the Orange River south of SR 80. This manatee viewing area provides public viewing and education about the species. FPL leases the property to the county for a nominal amount.

The adjacent land uses are light commercial and retail to the south of the property and some residential areas located toward the west. Mixed scrub with some hardwoods and wetlands, plus agriculture land, can be found to the east and further to the south. The Caloosahatchee National Wildlife Refuge is located across the Caloosahatchee River, northwest of the power plant.

e. General Environmental Features On and In the Site Vicinity

1. Natural Environment

The site is adjacent to the south bank of the Caloosahatchee River near the confluence of the Orange River and the Caloosahatchee. Much of the site is no longer in its original natural condition. However, a scattering of mangroves can be found along the river shoreline. Some mixed scrub with some hardwoods and wetlands can be found to the east and further to the south. Other than the occasional congregation of manatees noted below, FPL is not aware of any significant environmental features on the site or in the vicinity.

2. Listed Species

Construction and operation of the repowered facility, plus the new CT's/CC at the site, are not expected to affect any rare, endangered, or threatened species. The only known listed species associated with the site are the West Indian Manatees (*Trichechus manatus*: Federal - and - State listed as Endangered) which are attracted to the warmed waters in the vicinity of the site discharge and can be found congregating in the area during cool weather.

The Florida Natural Areas Inventory (FNAI) reports the presence of the Eastern Indigo Snake (*Drymarchons corais couperi*: Federal - and - State listed as Threatened) and Tricolored Heron (*Egretta tricolor*: State - listed as a Species of Special Concern) within a two-mile radius of the site.

3. Natural Resources of Regional Significance Status

No Natural Resource of Regional Significance is identified on the plant site in the Southwest Florida Regional Strategic Policy Plan.

4. Other Significant Features

FPL is not aware of any other significant features of the site.

f. Design Features and Mitigation Options

The design options currently being pursued for the Fort Myers site are the repowering of the two existing oil-fired boilers with natural gas-fired CT's and HRSG's, plus the installation of two stand-alone CT's. As previously mentioned, these two CT's will later be converted into one CC unit. All of this new generation equipment will be installed on the existing facility property and will make effective use of existing transmission facilities and infrastructure although some transmission line upgrades will be required. Steam developed in the new HRSG's will be directed to the existing steam turbines. FPL has contracted with Florida Gas Transmission (FGT) for a firm natural gas supply to the plant.

Mitigation options being planned for the capacity additions at Fort Myers include: the capture and reuse of plant process water, the use of combustion technology that is inherently low in air pollutant emissions, the reduction or cessation of heavy oil barge

traffic on the Caloosahatchee River, plumbing the sanitation system to Lee County's system and closing the on-site septic tanks, and closing the on-site ash basins.

Six CT's are being installed at the site in support of the repowering project. Several of these CT's are now operational in simple-cycle mode. Conversion to combined-cycle mode to complete the repowering process will occur during mid-2002.

g. Local Government Future Land Use Designations

The Local Government Future Land Use Plan designates the major portion of the site as Public Facilities and a small area as Resource Protection. Since there are no significant environmental resources on the site, and the "Resource Protection" designated area appears to be the location of a current tree nursery, FPL believes that this designation is in error.

h. Site Selection Criteria and Process

For the past several years, many of FPL's existing power plant sites have been considered potentially suitable sites for new, expanded, or repowered generation. The Fort Myers plant has been selected as a preferred site due to a combination of electrical transmission and system load factors, plus economic considerations. Environmental issues were not a deciding factor in FPL's site evaluation since none of the existing preferred and potential sites exhibit significant environmental sensitivity or other environmental issues. All of these sites are considered permissible.

i. Water Resources

The available surface water source is the Caloosahatchee River and the available groundwater source is the shallow aquifer.

j. Geological Features of Site and Adjacent Areas

The geology underlying the Fort Myers Plant consists of Quaternary Holocene and Pleistocene undifferentiated materials. The upper part of these undifferentiated materials consists of fine-to-medium-grained quartz sand with varying percentages of shell and clay. Hardpan frequently occurs at the base of the quartz sands. The lower section consists of shell beds with interbedded limestones. Underlying the undifferentiated materials are the Pliocene Tamiami formations, the Miocene Hawthorn formation, Oligocene Suwanee Limestone, the Eocene Crystal River and Williston formations, the Avon Park Limestone, and the Lake City Limestone.

Several stratigraphic units can be differentiated based upon shallow borings drilled on the plant property. Sand with some heterogeneous fill material related to past site construction activity covers most of the surface. It is underlain by layers of clayey sand and clay to a depth of approximately 23 feet. These units mantle a thicker clay unit with numerous shell fragments that occurs from 15 feet to about 55 feet below the surface. A silty sand with a trace of clay was encountered at 55 feet near the termination depth of one deep boring on the site.

The water table at the site occurs at levels from just under the surface to about 5 feet below grade. Locally, the surficial aquifer and surface water will generally flow toward the Caloosahatchee River. However, at the site, the intake and discharge canal will affect groundwater near the power block area. A drainage canal that borders the plant property on the west will affect groundwater flow along the western portion of the waste treatment area.

k. Projected Water Quantities For Various Uses

It is estimated that 150 gallons per minute (gpm) will be needed for industrial processing water for uses such as boiler makeup and service water. For industrial cooling (once-through cooling water), no significant increase is projected in the current 451,000 gpm usage rate. Other facility water uses may include irrigation, potable use, etc. The total volume of these uses is estimated to be about 5 gpm.

l. Water Supply Sources By Type

For industrial processing, FPL anticipates that groundwater will be available. For cooling water, for the repowered unit, FPL plans to continue to use its existing allocation from the Caloosahatchee River in a once-through cooling mode. The new CT's will be air-cooled. After the conversion of these CT's into a CC unit, a cooling tower with blowdown (i.e., a closed system) is expected to be used.

m. Water Conservation Strategies Under Consideration

A plan to treat and recycle equipment wash water, boiler blowdown, and equipment area runoff for use as service water would reduce ground water consumption. FPL would anticipate this site being designed and classified as a wastewater zero-discharge site following the completion of the repowering work.

n. Water Discharges and Pollution Control

Heated water discharge will be dissipated using both the existing once-through cooling water system and a multi-cell cooling tower. Non-point source discharges are not anticipated to be an issue because surface water runoff will be collected and used to recharge the surficial aquifer. Treating and recycling equipment wash water, boiler blowdown, and equipment area runoff will minimize industrial discharges. Storm water runoff will be collected and used to recharge the surficial aquifer via a stormwater management system. Design elements will be included to capture suspended sediments. Various facility permits mandate various sampling and testing activities, which will provide indication of any pollutant discharges. The facility employs a Best Management Practices (BMP) plan and Spill Prevention, Control and Countermeasure (SPCC) plan to control the inadvertent release of pollutants.

o. Fuel Delivery, Storage, Waste Disposal, and Pollution Control

A combustion turbine-based repowering project, plus the addition of the new CT's/CC, at the Fort Myers site requires a natural gas pipeline to be installed. Florida Gas Transmission has initiated permitting to install and operate such a facility. Virtually no waste is associated with natural gas firing.

p. Air Emissions and Control Systems

A natural gas-fired facility would generally have air pollutant emissions, which are substantially lower than emissions from the current oil-fired boilers. While several technologies are available for nitrogen oxide (NOx) emissions control, FPL is using a dry-low-NOx combustion turbine design. In these devices, combustion is staged in order to reduce the formation of combustion-derived oxides of nitrogen. FPL has proposed NOx emission limits for this facility that will be among the lowest in the state once the facility is constructed. Sulfur dioxide and particulate emissions are intrinsically low due to the lack of sulfur and solids in natural gas fuel. Carbon monoxide and volatile organic compound emissions can each be controlled via the use of efficient combustion rather than through the use of add-on control devices. Carbon dioxide emission rates associated with burning natural gas are well below those of other liquid or solid fuels. While the Fort Myers plant site is located within 100 kilometers of a Class I area (Everglades National Park), the reduction in emissions associated with repowering is expected to improve the air quality in the area as compared to current levels. CC and CT facilities have been permitted at several locations throughout the state of Florida including near Class I areas. Dry-low-NOx combustor systems have

been repeatedly demonstrated to be the Best Available Control Technology (BACT) for the control of NOx emissions for this technology pursuant to the requirements of the Clean Air Act.

q. Noise Emissions and Control systems

Lee County has a noise ordinance which limits noise at the receiving property line to 75 decibels. Noise emissions from the Fort Myers project s are not anticipated to approach this level based upon demonstrated noise control at similar natural gas-fired facilities (the Lauderdale plant in Broward County and the Martin plant in Martin County) and computer modeling of the anticipated noise emissions from the Fort Myers repowered plant. FPL will undertake studies to assure that noise level associated with the new CT's comply with Lee County noise standard.

r. Status of Applications

FPL has received all the permits necessary to construct and start up the repowered plant and the two new CT units. FPL will apply for permits for the CT's – to - CC conversion at the appropriate time.

Preferred Site #2: Sanford Plant, Volusia County

The site is located on the 1,718-acre FPL Sanford property just west of Lake Monroe on the north bank of St. Johns River in Volusia County. Current facilities on the site include three steam electric generating units (one with a nominal rating of 150 MW and two with nominal ratings of 400 MW). The site is within the city limits of Debarry and the community of Debarry is located approximately 2 miles to the northwest. The town of Deland is approximately 4 miles west of the site. The site has direct access to a four-lane highway, State Road (SR) 17-92, and barge access is available. The Sanford site has been listed as a potential or preferred site in previous FPL Site Plans.

FPL is currently in the process of adding new capacity at the Sanford site by replacing two existing oil-and gas-fired units (i.e., existing units #4 and #5) with advanced natural gas-fired combustion turbines (CT's) and heat recovery steam generators (HRSG's). This type of steam generation replacement is commonly called "repowering".

This repowering will enable FPL to produce significantly more electrical output with nearly the same environment impact. The repowering of units # 4 and # 5 will each produce approximately 570 additional MW during Summer conditions, and approximately 670

additional MW of generation during Winter conditions, beyond the current capabilities of these units. The two repowered units # 5 and # 4 are scheduled to be in-service by mid-2002 and late-2002, respectively. The existing 150 MW unit # 3 at Sanford will be unaffected by the repowering of units # 5 and # 4.

a. and b. U.S. Geological Survey (USGS) Map and Proposed Facilities Layout Map

A USGS map of the Sanford plant site, plus a map of the general layout of the proposed generating facilities at the site, are found at the end of this chapter.

c. Map of Site and Adjacent Areas

An overview map of the site and adjacent areas is also found at the end of this chapter.

d. Existing Land Uses of Site and Adjacent Areas

A large part of the property is covered by the 1,100-acre closed-cycle-cooling pond which occupies almost all of the northern portion of the site. The remainder of the site is primarily rangeland and the power plant facilities.

The surrounding land use is largely crop land and pasture. To the east of the plant there is a small residential area and some commercial/industrial land use. There are some residential areas mixed in with the agricultural areas located between the site and the St. John's River to the west. To the south is the St. Johns River and residential homes and commercial/industrial businesses are located along the south side of the river.

e. General Environmental Features On and In the Site Vicinity

1. Natural Environment

Small, scattered wooded areas can be found on the site. There are two small areas of wetland marsh on the site and a few acres of wetland forest along the riverbank. There are some wooded areas on the site, primarily upland coniferous forest. Forested and non-forested wetlands can be found to the west, adjacent to the river. River and wetland areas towards the northwest are designated as part of the Wekiwa River Aquatic Preserve and Wekiwa River State Preserve.

2. Listed Species

One inactive bald eagle (*Haliaeetus leucocephalus*: Federal - and - State listed as Threatened) nest has been found on the site. Bald eagles have also nested

in the Lake Monroe area. There are a number of other eagle nests in the vicinity of the site, primarily along the river. The Florida Natural Areas Inventory (FNAI) reports several Scrub Jay populations (*Aphelocoma coerulescens*: Federal – and - State listed as Threatened) located in scrub vegetation to the northwest of the site. West Indian Manatees (*Trichechus manatus*: Federal – and - State listed as Endangered) have also been found in this area.

3. Natural Resources of Regional Significance Status

The Wekiwa River Aquatic Preserve extends along the St. John's River in the vicinity of the plant.

4. Other Significant Features

FPL is not aware of any other significant features of the site.

f. Design Features and Mitigation Options

The design option for the Sanford site is the repowering of two existing oil-and gas-fired boilers with natural gas-fired combustion turbines (CT's) and heat recovery steam generators (HRSG's). Advanced CT's can be installed on the existing facility property to make effective use of existing transmission facilities and infrastructure although some transmission line upgrades will be required. Steam produced in the new HRSG's will be directed to two of the existing steam turbines. Natural gas-fired facilities represent one of the cleanest, most efficient technologies currently available for capacity additions to FPL's system.

Mitigation options being considered in the repowering project at Sanford include the reduction in the use of ground water, the use of combustion technology that is inherently low in air pollutant emissions, reduction in the amount of solid waste generated, plumbing the sanitary waste system into the Volusia county system, and the significant reduction of oil barge traffic on the St. Johns River.

g. Local Governmental Future Land Use Designations

The site is designated as "Industrial Utilities" in the Local Government land use plan. The city is currently updating its Land Use Plan. It is expected that the name, but not the expected use designation, may change. Land use designation of the surrounding area is primarily Agricultural. There is an area of "Public Institution" around Lake Monroe to the southeast and a small area of "Mixed Use" to the west along Barwick Road.

h. Site Selection Criteria and Process

The Sanford plant has been selected as a preferred site due to a combination of system load and economic factors. Environmental issues were not a deciding factor in FPL's site evaluation since none of the existing preferred and potential sites exhibit significant environmental sensitivity or other environmental issues. All are considered permissible.

i. Water Resources

For surface water supply, the available water resource is the St. John's River and / or the on-site cooling pond, which is periodically refilled from the St. John's River. For groundwater supply, the available resources are the shallow aquifer or the Floridan Aquifer.

j. Geological Features of Site and Adjacent Areas

The near-surface geology of Volusia County, like that of most of north central Florida, is represented by late Tertiary and Quaternary geologic units. Soils in the vicinity of the plant include unconsolidated Pleistocene to Recent sands, with intervening beds of shells and clay. These deposits form the reservoir for the surficial aquifer in the county. Deposits of Pliocene or Miocene clay with some sand underlie the aquifer. These low-permeability units serve to confine groundwater under pressure in the underlying porous limestone formations of Eocene age. These formations are part of the principal hydrologic unit referred to as the Floridan Aquifer. This aquifer, the top of which generally occurs through the region at or below 100 feet, is the major source of potable groundwater in Volusia County. Two faults, one trending north-to-south, the other trending east-to west, intersect a number of miles north of the site. Downward displacement of the fault is hypothesized as being approximately 60 to 100 feet.

k. Projected Water Quantities for Various Uses

FPL has estimated that 150 gallons per minute (gpm) would be required for industrial processing purposes (boiler makeup, service water, etc.). Note that Units # 5 and # 4 both currently take their cooling water directly from an on-site FPL cooling pond and are expected to continue to do so once the units are repowered. The cooling water needs for the repowered facilities are expected to increase over what is currently used, due primarily to the increased heat loading to the cooling pond that will result from operating the larger repowered units more than they have been operated in the past, and corresponding evaporative losses. Therefore, greater quantities of water may be used.

Existing Unit # 3 will use water from the St. John's River in a once-through cooling mode.

FPL also evaluated alternative sources of water to meet the expected needs of the site. It is anticipated that the existing off-site wells and the existing once-through cooling water system and cooling pond would continue to be used after the repowering project is completed, albeit the use of groundwater is expected to decrease significantly from past usage.

I. Water Supply Sources by Type

The available surface water supply source is the St. Johns River. The Floridan Aquifer is an available groundwater source for service water and boiler water.

m. Water Conservation Strategies Under Consideration

A plan to treat and recycle equipment wash water, boiler blowdown, and equipment area runoff for use as service water would reduce groundwater consumption.

n. Water Discharges and Pollution Control

Heated water discharge will be dissipated using the existing once-through cooling water system. Non-point source discharges are not anticipated to be an issue because surface water runoff is planned to be collected and reused. Treating and recycling equipment wash water, boiler blowdown, and equipment area runoff will minimize industrial discharges. Storm water runoff will be collected and used to recharge the surficial aquifer via a stormwater management system. Design elements will be included to capture suspended sediments. Various facility permits mandate various sampling and testing activities, which will provide indication of any pollutant discharges. The facility employs a Best Management Practices (BMP) plan and Spill Prevention, Control and Countermeasure (SPCC) plan to control the inadvertent release of pollutants.

o. Fuel Delivery, Storage, Waste Disposal, and Pollution Control

The repowered facilities at the Sanford site would require a larger natural gas pipeline to be installed. FPL has contracted with Florida Gas Transmission Company (FGT) to permit, install, and operate such a facility. Virtually no waste is associated with natural gas firing.

p. Air Emissions and Control Systems

A natural gas-fired facility would generally have air pollutant emissions which are substantially lower than emissions from the current oil-fired boilers. While several technologies are available for nitrogen oxide (NOx) emissions control, the most appropriate candidate for the Sanford site is a dry-low-NOx combustion turbine design type. In these types of devices, combustion is staged in order to reduce the formation of combustion-derived oxides of nitrogen. Sulfur dioxide and particulate emissions are intrinsically low, due to the lack of sulfur and solids in natural gas fuel. Carbon monoxide and volatile organic compound emissions can each be controlled via the use of efficient combustion, rather than through the use of add-on control devices. CC and CT facilities have been permitted at several locations throughout the state of Florida. Dry-low-NOx combustor systems have been repeatedly demonstrated to be the Best Available Control Technology (BACT) for the control of NOx emissions for this technology pursuant to the requirements of the Clean Air Act.

q. Noise Emissions and Control Systems

Noise emissions from the project are not anticipated to be significantly different from current levels at the existing plant. FPL will install appropriate sound attenuation devices such as insulation on high-energy piping systems in order to ensure that sound levels do not exceed allowable levels. Similar natural gas-fired facilities (the Lauderdale plant in Broward County and the Martin plant in Martin County) have been constructed and operated without exceeding allowable noise levels.

r. Status of Applications

FPL has now acquired all permits needed to commence construction. Modifications to operating permits will continue to be pursued as necessary through 2001.

Preferred Site #3: Martin Plant, Martin County

The Martin site is located approximately 40 miles northwest of West Palm Beach, 5 miles east of Lake Okeechobee, and 7 miles northwest of Indiantown in Martin County, Florida. The site is bounded on the west by the Florida East Coast Railway (FEC) and the adjacent South Florida Water Management District (SFWMD) L-65 Canal, on the south by the St. Lucie Canal (C-44 or Okeechobee Waterway), and on the northeast by SR 710 and the adjacent CSX Railroad.

The Martin site was identified in 1987 as a preferred location for development of coal gasification/combined cycle electric generation facilities and subsequent FPL Site Plans have continued to identify this site as a preferred site.

The existing 2,588 MW of Summer generating capacity at FPL's Martin plant occupies a portion of the approximately 11,300-acre Martin site which is wholly owned by FPL. The generating capacity is made up of two steam units (units # 1 and # 2), plus two combined cycle units (units # 3 and # 4). The site includes a 6,800-acre cooling pond (6,500 acres of water surface and 300 acres of dike area) and approximately 300 acres for the existing power plant units and related facilities.

Additional generating capacity will be added to the site in several stages. First, two combustion turbines (CT's) are being added to the site in 2001. These two CT's will then be converted into one combined cycle (CC) unit in 2005. An additional CC unit (Martin Unit # 5) will also be added in 2005. Finally, one more CC unit (Martin Unit # 6) will be added in 2006.⁵

The two new peaking CT's are currently under construction will add 298 MW (Summer) and 362 MW (Winter) of additional capacity to FPL's system. The later conversion of these two CT's to one CC unit will add approximately 249 MW (Summer) and 234 MW (Winter) of capacity. The addition of the Martin units # 5 and # 6 will each add approximately 547 MW (Summer) and 596 MW (Winter).

a) and b) U.S. Geological Survey (USGS) Map and Proposed Facilities Layout Map

A USGS map of the Martin plant site, plus a map of the general layout of the proposed generating facilities at the site, are found at the end of this chapter.

c) Map of Site and Adjacent Areas

An overview map of the site and adjacent areas is also found at the end of this chapter.

d) Existing Land Uses of Site and Adjacent Areas

A major portion of the site consists of a 6,800-acre cooling pond. The existing power plant facilities are located on approximately 300 acres. To the east of the power plant

⁵ Ultimately, coal gasification facilities may be constructed and operated to supply coal-derived gas to existing Units #3 and #4 and/or these new CC units, if economically justified. FPL currently has no plans to introduce coal gasification at the site. Coal gasification would not produce additional megawatts, so it is not discussed further in this document. Approx. 1,300 acres could potentially be used to accommodate the associated coal handling, coal storage, by-product handling, and storage facilities which would be constructed if coal gasification is implemented. In such a case, natural gas and/or distillate fuel oil could serve as backup fuels.

there is an area of mixed pine flatwood with a scattering of small wetlands. To the north of the reservoir there is a 1,200-acre area which has been set aside as a mitigation area. There is peninsula of wetland forest on the west side of the reservoir which is named the Barley Barber Swamp. The Barley Barber Swamp encompasses 400 acres and is preserved as a natural area. There us also a 10 kilowatt (KW) photovoltaic energy facility at the south end of this site.

e) General Environment Features On and In The Site Vicinity

1) Natural Environment

As noted above, the Barley Barber Swamp is located on the site. There is also a 1,200-acre mitigation area in the northern area of the site where wetlands and uplands have been restored. Along the south and west sides of the cooling pond is an area where the vegetation has been allowed to return to its natural state in order to serve as a wildlife corridor. FPL has preserved a Florida Panther corridor along the west side of the cooling pond. There are pine flatwoods and small scattered wetlands to the east of the plant.

2) Listed Species

Construction and operation of new units at the site are not expected to affect any rare, endangered, or threatened species. There are two active Bald Eagle (*Haliaeetus leucocephalus*: Federal - and - State listed as Threatened) nests that have been on the site for many years. The Florida Natural Areas Inventory (FNAI) database notes a record of Eastern Indigo Snakes (*Drymachon coralais* *couper* which are Federal - and - State listed as Threatened) in the Barley Barber Swamp. A number of other Bald Eagle nests and sightings of Eastern Indigo Snakes are reported by the FNAI database within a two-mile radius of the site. Infrequent sightings of Florida Panther have been made in the site area.

3) Natural Resources of Regional Significance Status

The Treasure Coast Regional Planning Council lists the "FPL Preserve", including the Barley Barber Swamp, as a Significant Regional Facility. Natural communities such as uplands and wetlands are also generically listed as Resources of Regional Significance.

4) Other significant features

FPL is not aware of any other significant features of the site.

f) Design Features and Mitigation Options

The design options are to add four additional CT's and two HRSG's which will comprise the Martin # 5 and #6 units, in 2005 and 2006, respectively. In addition, two new CT's will begin operation in mid – 2001. In 2005 they will be converted into one CC unit. Natural gas delivered via pipeline is envisioned as the fuel type for these units (with distillate serving as a backup fuel for the stand-alone CT's.). Natural gas-fired facilities are among the cleanest, most efficient technologies currently available.

Mitigation options being considered in the addition of this capacity at the existing Martin site include the capture and reuse of plant process water and rainwater. The facility already encompasses several preserved areas where wildlife is abundant.

g) Local Government Future Land Use Designations

Local government future land use designation for the site is "Public Utilities". Designations for the surrounding area are primarily "Agricultural". There are also limited areas of "Agricultural Ranchette", "Industrial", and a small "Commercial" area designation. To the southeast of the property, fronting on the St. Lucie Canal, there is an area designated for "Public Conservation".

h) Site Selection Criteria and Process

For the past several years, a number of FPL's existing power plant sites have been considered as potentially suitable sites for new or repowered generation. The Martin plant has been selected as a preferred site due to a combination of site, location, and economic factors. The Martin site has been selected as a preferred site due to a combination of electrical transmission and system load factors, plus economic considerations. Environmental issues were not a deciding factor in FPL's site evaluation since none of the existing preferred and potential site exhibit significant environmental sensitivity or other environmental issues. All of these sites are considered permissible.

i) Water Resources

Surface water resources currently used at the Martin facility include the cooling pond, which takes its water from the St. Lucie canal. The available groundwater resource is the shallow aquifer which is used as a source of potable water and for service water for Units # 1 and # 2. Both of these sources are available for use with the site expansion.

j) Geological Features of Site and Adjacent Areas

FPL's Martin site is underlain by approximately 13,000 feet of sedimentary rock strata. The basement complex in this area consists of Paleozoic igneous and metamorphic rocks about which little is known due to their great depth.

Overlying the basement complex to the ground surface are sedimentary rocks and deposits that are primarily marine in origin. Below a depth of about 400 feet these rocks are predominantly limestone and dolomite. Above 400 feet the deposits are largely composed of sand, silt, or clay. The deepest formation in Martin County on which significant published data are available is the Eocene Age Avon Park. Limited information is available from wells penetrating the underlying Lake City formation. The published information on the sediments comprising the formations below the Avon Park Limestone in western Martin County is based on projections from deep wells in Okeechobee, St. Lucie, and Palm Beach counties.

k) Projected Water Quantities for Various Uses

The estimated additional quantity of water required for industrial processing is 130 gallons per minute (gpm) for uses such as boiler water and service water. FPL operates on-site water treatment systems for each of these uses. Cooling water for new Units # 5 and # 6, as well as for the other new CC unit which will result from the conversion of the 2 new CT's into a CC unit, will be supplied from the on-site 6,800-acre cooling pond. The CT's will be air-cooled until they are converted into a CC unit. Makeup water for the pond is taken from the St. Lucie canal. The current makeup water quantity to the cooling pond (approximately 4,800 gpm) is expected to be adequate for the proposed expansion. Water quantities needed for other uses such as irrigation and potable water are estimated to be approximately 5 gpm.

l) Water Supply Sources by Type

All additional capacity at the site will utilize the existing on-site cooling pond as the source of cooling water and as a heat sink for the dissipation of cooling water heat. The cooling pond operates as a "closed cycle" system in which heated water from the generating units loses its heat as it is circulated within the pond and back around to the plant intake. Makeup water to the pond is withdrawn from the St. Lucie Canal as needed to replace net evaporation and seepage losses from the pond. Such needs will comply with the existing agreement between FPL and the South Florida Water Management District (SFWMD) regarding allocation of cooling water to the pond and with SFWMD's regulations for consumptive water use.

The existing water treatment system at the plant, which provides treated water for use in the Unit 1 and 2 boilers, as well as the HRSG's associated with Units 3 and 4, will be used to provide treated water for the two new, and expanded to provide treated water for New Unit # 5. To avoid impacts to the surficial aquifer, FPL and SFWMD have agreed that the process water for Units # 3 and # 4 can be obtained initially from the cooling pond, but upon completion of Units # 5 and # 6, process water for all four CC units will be obtained solely from the Floridan Aquifer via approximately 1,500-foot deep wells.

m) Water Conservation Strategies Under Consideration

Impacts on the surficial aquifer will be reduced by changing the source of plant process water to the Floridan aquifer, upon completion of Units #5 and #6. In addition, the facility captures and reuses process water whenever feasible, and manages stormwater in such a manner so as to recharge the surficial aquifer.

n) Water Discharges and Pollution Control

Heated water discharges will be dissipated in the cooling pond. Non-point source discharges are not an issue since there are none at this facility. Industrial discharges will be minimized by treating and recycling equipment wash water, boiler blowdown water, and equipment area runoff. Storm water runoff is collected and used to recharge the surficial aquifer via a stormwater management system. Design elements have been included to capture suspended sediments. Facility permits mandate various sampling and testing activities, which provide indication of any pollutant discharges. The facility employs a Best Management Practices (BMP) plan and Spill Prevention, Control and Countermeasure (SPCC) plan to control the inadvertent release of pollutants.

o) Fuel Delivery, Storage, Waste Disposal, and Pollution Control

The site is already serviced by multiple fuel delivery facilities. However, the addition of future natural gas-fired CC units would require an enlargement of the existing pipeline(s), the installation of a new pipeline, or the addition of another natural gas pipeline compressor station. There are currently two natural gas supply lines into the facility, as well as an oil pipeline, which serve the existing steam boilers and combined cycle generating units. The existing natural gas line will also serve the new CT's.

p) Air Emissions and Control Systems

FPL's plan for the two new CT's/CC and for new Units # 5 and # 6 are subject to "New Source Review" under Federal and State Prevention of Significant Deterioration (PSD) regulations. This review required these units to meet New Source Performance Standards (NSPS) and that Best Available Control Technology (BACT) be selected to control emissions of those pollutants emitted in excess of applicable PSD significant emission rates. The primary purpose of BACT analysis is to minimize the allowable increases in air pollutants and thereby increase the potential for future economic growth without significantly degrading air quality.

Air emission rates will be limited to levels far below NSPS requirements. In addition, BACT determination was established for the following pollutants: sulfur dioxide (SO₂), sulfuric acid mist (H₂SO₄), nitrogen oxides (NO_x), particulates (PM₁₀ and TSP), carbon monoxide (CO), volatile organic compounds (VOC), lead, beryllium, mercury, and inorganic arsenic. By stipulation, the Department of Environmental Protection (DEP) has determined final BACT for Units # 3 and # 4 firing natural gas and distillate oil. Emission limitations and conditions concerning development of subsequent units at the site (e.g. the two CT's/CC and Units # 5 and # 6) reflect a preliminary BACT determination for those phases to support certification of ultimate site capacity and shall be determined finally upon review of supplemental applications.

Emission limits for the new CT's currently under construction reflect BACT limits of 10 ppm for natural gas firing and 42 ppm for distillate oil firing. Different limits were also established for operation of the peaking units in power augmentation and peaking modes. FPL projects that lower emission levels to those listed above will be required for the conversion of the CT's to CC operation and for the operation of new Units # 5 and # 6.

q) Noise Emissions and Control Systems

A field survey and impact assessment of noise expected to be caused by unit construction at the site indicated that construction noise will be below current noise levels at the residents nearest the site. Noise from the operation of the new units will also be within allowable levels.

r) Status of Applications

A Site Certification application was filed in December, 1989, for the construction and operation of the Martin Coal Gasification/Combined Cycle project under the Florida Electrical Power Plant Siting Act.

On June 15, 1990, the Public Service Commission issued a Determination of Need Order for proposed Martin Units # 3 and # 4. This determination of need applies only to the first phase of the Project, or 832 MW of combined cycle generation. The Siting Board issued a Land Use Order on June 27, 1990. The Certification Hearing was held on November 5-7, 1990. As mentioned earlier, on February 12, 1991, the Governor and Cabinet, serving as the Siting Board, approved the construction and operation of natural gas-fired combined cycle Units # 3 and # 4 and determined that the Martin Site has capacity to accommodate additional combined cycle units fueled by natural gas, fuel oil, or coal-derived gas produced at the site which will encompass new Units # 5 and # 6.

Since the initial certification in 1991, the certification has been modified five times to provide authorization for items such as CT testing, increasing the cooling pond elevation, incorporating changes from other permits, and incorporating a custom fuel monitoring program. For the addition of the two CT's mentioned above, FPL obtained a sixth modification to the existing site certification in August 2000.

In order to convert these two CT's from simple cycle to CC configuration, a seventh modification to the Site Certification will be required. FPL will file an application for this modification at the appropriate time.

Preferred Site #4: Midway Substation Property, St. Lucie County

The site is located on the 122-acre Midway Substation property. Current facilities on the site include an electric substation. The site has direct access to a two-lane highway, State

Road (SR) 712. The nearest town is White City, which is approximately 5 miles east of the site. The City of Fort Pierce is approximately 9 miles northeast of the site. The Midway site has not previously been listed as a potential or preferred site in previous FPL Ten Year Power Plant Site Plans.

FPL is planning to add new capacity by constructing a combined cycle (CC) gas-fired facility on the property. The new plant would consist of two combustion turbines (CT's), two heat recovery steam generators (HRSG's) and one steam turbine-generator. This addition will add approximately 547 MW (Summer) and 596 MW (Winter) to FPL's system. The construction of the CC unit is planned to be completed and the plant in service by mid-2005.

a. and b. U.S. Geological Survey (USGS) May and Proposed Facilities Layout Map

A USGS map of the Midway Substation site, plus a map of the general layout of the proposed generating facilities at the site, are found at the end of this chapter.

c. Map of Site and Adjacent Areas

An overview map of the site and adjacent areas is also found at the end of this chapter.

d. Existing Land Uses of Site and Adjacent Areas

The land on the site is currently dedicated to industrial and agricultural use. Much of the site is currently not being used.

Developed portions of the adjacent properties are primarily agricultural (orange groves and cattle grazing). Undeveloped portions include mixed scrub with some hardwoods and wetlands.

e. General Environmental Features On and In the Site Vicinity

1) Natural Environment

The majority of the sixty-acre site is improved pasture, with active grazing by cattle occurring over the entire site. There is a strip of upland pine/palmetto community and small, isolated wetlands between the transmission corridor to the east and the improved pasture to the west. The isolated wetlands are of moderate ecological value and could be avoided by using the improved pasture to the west. There is an area of historic wetlands in the western improved pasture area of very low functional value over which the Florida Department of Environmental Protection will claim jurisdiction. Minimal mitigation ratios would be expected based on the condition of the historic wetlands.

2) Listed Species

One active gopher tortoise (*Gopherus polyphemus*: State species of special concern) nest was observed in the pine/palmetto upland area. No indication of any other listed species was observed.

3) Natural Resources of Regional Significance Status

The Savannas State Preserve lies approximately 7 miles to the east of the proposed site.

4) Other Significant Features

FPL is not aware of any other significant features of this site.

5) Natural Resources of Regional Significance Status

No Natural Resource of Regional Significance is identified on the plant site in the Southwest Florida Regional Strategic Policy Plan.

6) Other Significant Features

FPL is not aware of any other significant features of the site.

f. Design Features and Mitigation Options

The design option currently being pursued for the Midway site is the construction of a 500 MW (nominal) CC unit, using natural gas-fired CT's and HRSG's. All of this new generation equipment will be installed on the existing facility property and make effective use of existing transmission facilities and infrastructure although some transmission line upgrades will be required. Steam developed in the new HRSG's will be directed to a new steam turbine.

Operation of the Midway unit is dependent upon securing a firm natural gas supply to the site which is both sufficient for fueling the electrical capacity involved and economically attractive. FPL is exploring a contract with Florida Gas Transmission (FGT) for this fuel supply.

Mitigation options being planned for the capacity additions at Midway include: the capture and reuse of plant process water, the use of combustion technology that is inherently low in air pollutant emissions, and the use of gray water if available,

g. Local Government Future Land Use Designations

A Comprehensive Plan Amendment, a rezoning and a Conditional Use permit will be required from St. Lucie County; followed by a Site Plan review & approval. The current zoning for the substation is "Utility", but is "MXD" (mixed use development) on the rest of the property. FPL will need to change that to "Utility" in order to develop the site.

Two public hearings would be required; one for the Comprehensive Plan, Rezoning and Conditional Use permit (if FPL is able to file all simultaneously), and a second for the Site Plan approval.

h. Site Selection Criteria and Process

For the past several years, many of FPL's existing facility sites have been considered potentially suitable sites for new, expanded, or repowered generation. The Midway facility has been selected as a preferred site due to a combination of electrical transmission and system load factors, plus economic considerations. Environmental issues were not a deciding factor in FPL's site evaluation since none of the existing preferred and potential sites exhibit significant environmental sensitivity or other environmental issues. All of these sites are considered permissible.

i. Water Resources

No surface water source is available at the site. The groundwater source would either be the shallow aquifer or a local source of gray water.

j. Geological Features of Site and Adjacent Areas

The site lies in the Atlantic Coastal Lowlands physiographic province. The Lowlands are characterized by monotonously flat, low elevations (less than 25 feet above mean sea level) that are swampy and poorly drained. These lowlands (or flatlands as they are also called) represent the shallow, flat bottoms of ancient seas.

Thick sequences of sedimentary rocks overlie the crystalline basement rocks. These sediments are over 12,000 feet thick in eastern St. Lucie county. Sediments within a few hundred feet of the surface generally consist of clastics, such as sands, silts and

clays; and carbonates, such as limestones, dolomites or shell beds. Many of these lithologic units are interbedded or interfingered and are gradational from one to another. Sediments exposed at the surface range from Miocene age (26 to 12 million years ago) through Pleistocene age (3 to 2 million years ago) to Recent age. A veneer of Pleistocene sand covers almost all of St. Lucie county. Marine processes laid down the shell beds, clays, sands and limestone. During the last two million years of Pleistocene time, the sea level rose more than 100 feet and fell more than 200 feet below present sea levels. These sea level fluctuations occurred several times, alternately covering and exposing parts of the Floridan Plateau. Each significant change in sea level created a different environment of deposition for any given location across the relatively flat Plateau. The result of these sea level changes is a very complex interbedding and interfingering of heterogeneous lithologies in the subsurface stratigraphy.

k. Projected Water Quantities For Various Uses

It is estimated that 150 gallons per minute (gpm) will be needed for industrial processing water for uses such as inlet air-cooling, NOx control during distillate oil firing, and service water. Other facility water uses may include irrigation, potable use, etc. The total volume of these uses is estimated to be about 5 gpm.

l. Water Supply Sources By Type

For industrial processing and cooling water, FPL plans to use either gray water or groundwater.

m. Water Conservation Strategies Under Consideration

FPL plans to utilize an auxiliary equipment cooling system that will recirculate cooling water through the plant equipment, thus minimizing water losses.

n. Water Discharges and Pollution Control

Water discharges will be minimal. Storm water runoff will be collected and used to recharge the surficial aquifer via a stormwater management system. Design elements will be included to capture suspended sediments. It is anticipated that various facility permits will mandate various sampling and testing activities, which will provide indication of any pollutant discharges. The facility will employ a Best Management Practices (BMP) plan and Spill Prevention, Control and Countermeasure (SPCC) plan to control the inadvertent release of pollutants.

o. Fuel Delivery, Storage, Waste Disposal, and Pollution Control

A CC project at the Midway site requires a natural gas pipeline to be installed. FPL anticipates working with a local natural gas utility to permit, install, and operate such a facility. Virtually no waste is associated with natural gas firing.

p. Air Emissions and Control Systems

A natural gas-fired CC facility would generally have air pollutant emissions that are among the lowest currently available for electric power production. While several technologies are available for nitrogen oxide (NOx) emissions control, FPL plans to use a dry-low-NOx combustion turbine design. In these devices, combustion is staged in order to reduce the formation of combustion-derived oxides of nitrogen. FPL anticipates NOx emission limits for this facility that will be among the lowest in the State once the facility is constructed. Sulfur dioxide and particulate emissions would be intrinsically low due to the lack of sulfur and solids in natural gas fuel. Carbon monoxide and volatile organic compound emissions can each be controlled via the use of efficient combustion rather than through the use of add-on control devices. Carbon dioxide emission rates associated with burning natural gas are well below those of other liquid or solid fuels. CC and CT facilities have been permitted at several locations throughout the State of Florida. Dry-low-NOx combustor systems have been repeatedly demonstrated to be the Best Available Control Technology (BACT) for the control of NOx emissions for this technology pursuant to the requirements of the Clean Air Act.

q. Noise Emissions and Control systems

St. Lucie County has a noise ordinance which limits noise at the receiving property line to 55-75 decibels, depending upon the adjacent land use classification. Noise emissions from the Midway project are not anticipated to approach these levels based upon demonstrated noise control at similar natural gas-fired facilities (the Lauderdale plant in Broward County and the Martin plant in Martin County) and computer modeling of the anticipated noise emissions from the Midway facility. FPL will undertake studies to assure that noise level associated with the new CT's comply with St. Lucie County noise standard.

r. Status of Applications

FPL will apply for all the permits necessary to construct and start up the new CC unit at the appropriate time.

IV.F.2. Potential Sites

Three FPL-owned sites are identified as the next most likely potential sites for future generation after the four preferred sites just discussed. These three sites are considered the next most likely potential sites due to considerations of space, infrastructure, and accessibility to fuel and transmission facilities. These sites are located in Brevard, Palm Beach, and Broward Counties. These sites are suitable for different capacity levels and technologies, and they will remain as potential sites pending future decisions on how best to meet the timing and magnitude of FPL's future capacity needs.⁶

Each of these potential sites offers advantages and disadvantages relative to engineering considerations and/or costs associated with the construction and operation of feasible technologies. In addition, each potential site has different characteristics, which could require further definition and attention. For purposes of estimating water usage amounts, it is assumed that a natural gas-fired CC unit would be the technology of choice for any capacity additions at the sites.

Permits are presently considered to be obtainable for all three sites, assuming measures can be taken to mitigate any particular site-specific environmental concerns. None of the sites exhibit any significant environmental constraints. The potential sites are briefly discussed below. (Note: The order in which the sites are discussed below does not reflect a relative ranking of these sites in regard to how likely it is for FPL to add capacity at the site.)

Potential Site #1: Cape Canaveral Plant, Brevard County

The site is located on the FPL Cape Canaveral property in unincorporated Brevard County. The city of Port St. Johns is located less than a mile away. The site has direct access to a four-lane highway, US 1, and barge access is available. A rail line is located near the plant. The existing facility consists of two 400 MW (nominal) steam boiler type generating units.

a) U.S. Geological Survey (USGS) Map

A USGS map of the Cape Canaveral plant site is found at the end of this chapter.

b) and c) Land Uses and Environmental Features

⁶ As has been described in previous FPL Plant Site Plans, FPL also considers a number of other sites as possible sites for future generation additions. These include the remainder of FPL's existing generation sites as well as non-FPL-owned sites located in Hardee, Highlands, Glades, and Hendry Counties.

This site is located on the Indian River. The land is primarily dedicated to industrial use with surrounding grassy areas and a few acres of remnant pine forest. The land adjacent to the site is dedicated to light commercial and residential use. There are no significant environmental features on the site.

d) and e) Water Quantities and Supply Sources

FPL projects that an increase of up to 260 gallons per minute (gpm) would be required for industrial processing use (boiler makeup, service water, etc.) It is expected that industrial cooling water needs could be met using the current 550,000 gpm once-through cooling water quantity. For industrial processing, FPL would use existing on-site wells. For industrial cooling, the Indian River would continue to be utilized.

Potential Site #2: Riviera Plant, Palm Beach County

This site is located on the FPL Riviera Plant property in Riviera Beach, Palm Beach County. The site has direct access to a four-lane highway, US 1, and barge access is available. A rail line is located near the plant. The facility currently houses two operational 300 MW (nominal) steam boiler generating units and one retired 50 MW generating unit.

a) U.S. Geological Survey (USGS) Map

A USGS map of the Riviera plant site is found at the end of this chapter.

b) and c) Land Uses and Environmental Features

The land on the site is primarily covered by the existing generation facilities with some open maintained grass areas. There is a small manatee viewing area on the site which is operated seasonally by FPL. Adjacent land uses include port facilities and associated industrial activities, as well as light commercial and residential development. The site is located on the Intracoastal Waterway near the Lake Worth Inlet.

d) and e) Water Quantities and Supply Sources

Additional industrial processing water needs are estimated to be up to 40 gallons per minute (gpm). Industrial cooling water needs are estimated to be up to 54,000 gpm using the existing once-through cooling water system. The existing municipal water supply would be used for industrial processing water if additional generating capacity is placed at Riviera. For once-through cooling water, FPL would continue to use Lake Worth as a source of water.

Potential Site #3: Port Everglades Plant, Broward County

This site is located on the 94-acre FPL Port Everglades plant site in Port Everglades, Broward County. The site has convenient access to State Road (SR) 84 and Interstate 595. Currently, direct barge access is not available. A rail line is located near the plant. The existing plant consists of four steam boiler generating units: two 200 MW (nominal) and two 400 MW (nominal) sized units.

a) U.S. Geological Survey (USGS) Map

A USGS map of the Port Everglades plant site is found at the end of this chapter.

b) and c) Land Uses and Environmental Features

The land on the site is primarily industrial. The adjacent land uses are port facilities and associated industrial activities, oil storage, cruise ships, and light commercial.

d) and e) Water Quantities and Supply Sources

FPL estimates that up to 130 gallons per minute (gpm) of industrial processing water would be required for uses such as boiler makeup, fogger usage, and service water. FPL would expect to use the existing municipal water supply for industrial process water. For cooling water, FPL would anticipate that the existing 320,000 gpm once-through cooling seawater source would continue to be used.

***Environmental and Land Use Information:
Supplemental Information***

Preferred Site: Fort Myers Plant

(This page is left intentionally blank)

Ft. Myers Plant

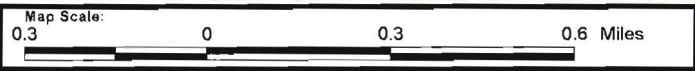
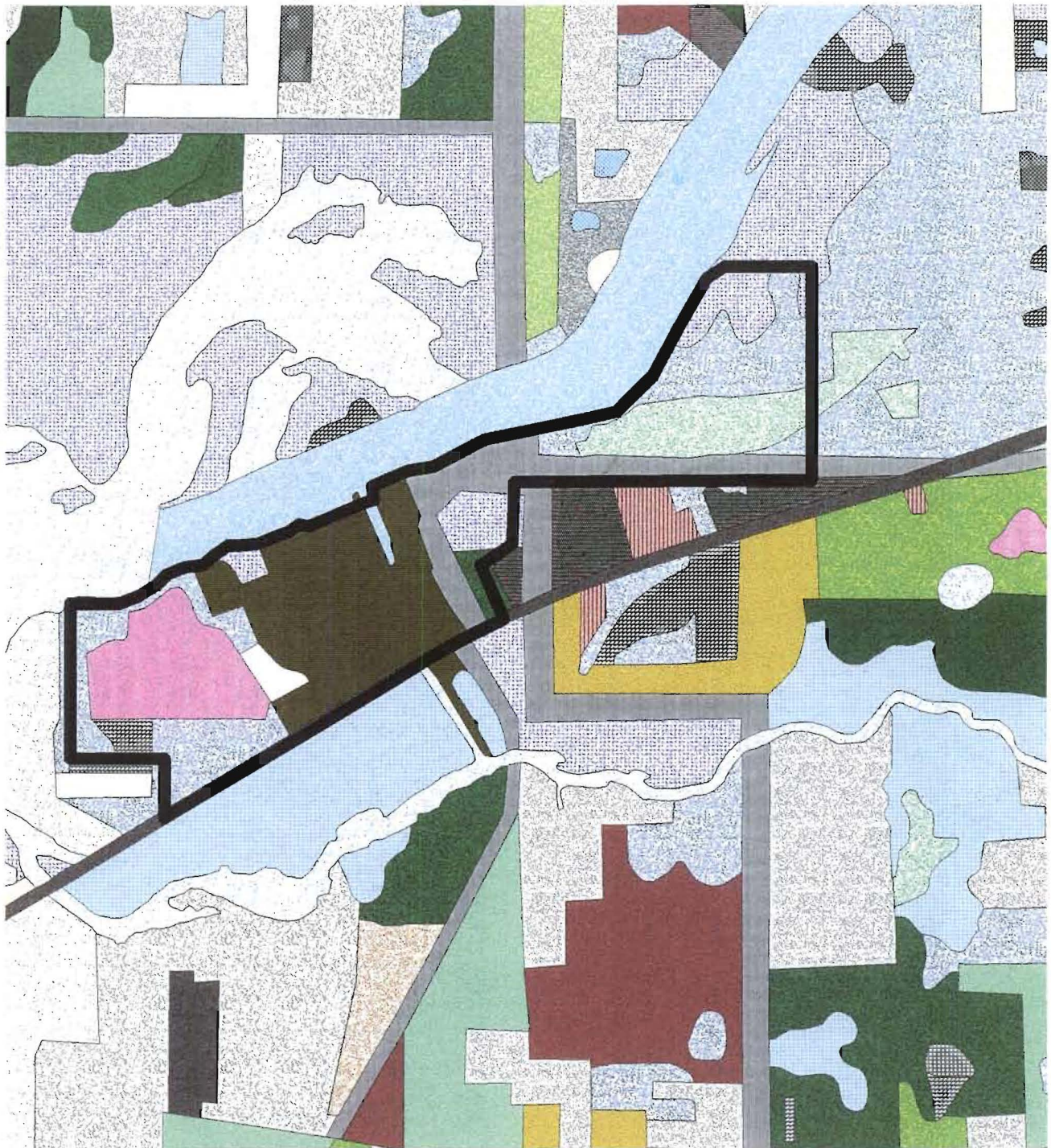

Land Use Data Source
1995 SFWMD Data level 3



Figure IV.F. 1
Ft. Myers Plant
Level 3 Land Usage

Copyright 1998 FPL All Rights Reserved
No expressed or implied warranties.
The materials contained herein may contain inaccuracies. The user is warned to utilize at his/her own risk and the user assumes risk of any and all loss. All boundaries are approximate.



Land Usage Legend Level 3

-  Ft Myers Plant Boundary
- Surrounding Land Usage**
-  Mobile Homes
-  Fixed Single Family Units
-  Fixed Single Family Units 2-5 du/ac
-  Fixed & Mobile Units
-  Fixed Single Family Units
-  Multiple Dwelling Units Low Rise
-  Multiple Dwelling Units High Rise
-  Retail Sales & Service
-  Shopping Centers
-  Wholesale Sales & Service
-  Junkyards
-  Professional Services
-  Tourists Services
-  Oil & Gas Storage
-  Mixed Commercial & Services
-  Cemeteries
-  Food Processing
-  Other Light Industrial
-  Other Heavy Industrial
-  Strip Mines
-  Sand & Gravel Pits
-  Rock Quarries
-  Educational Facilities
-  Religious
-  Medical & Health Care
-  Governmental
-  Correctional
-  Other Institutional
-  Commercial Child Care
-  Swimming Beach
-  Golf Courses
-  Marinas & Fish Camps
-  Parks & Zoos
-  Community Recreational Facilities
-  Historical Sites
-  Other Recreational
-  Undeveloped Land Within Urban Areas
-  Inactive Land W/Street Pattern
-  Urban Land In Transaction
-  Other Open Land
-  Improved Pastures
-  Unimproved Pastures
-  Woodland Pastures
-  Row Crops
-  Field Crops
-  Sugar Cane Fields
-  Citrus Groves
-  Tree Nurseries
-  Sod Farms
-  Ornamentals
-  Floriculture
-  Horse Farms
-  Dairies
-  Aquaculture
-  Fallow Crop Land
-  Herbaceous Rangeland
-  Palmetto Prairies
-  Coastal Scrub
-  Other Scrubs & Brush
-  Mixed Rangeland
-  Pine Flatwoods
-  Melaleuca Infested
-  Longleaf Pine - Xeric Oak
-  Sand Pine
-  Pine - Mesic Oak

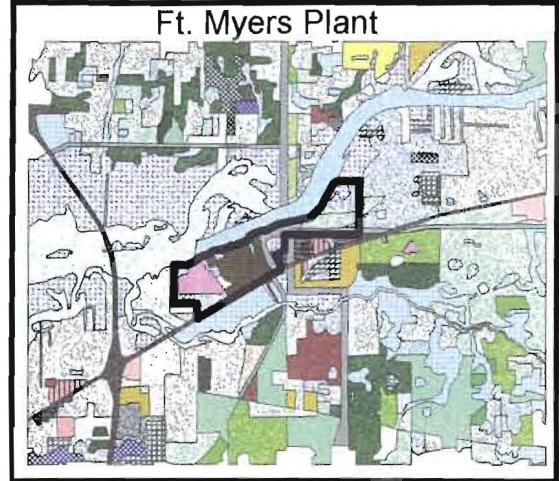

Continued Legend

-  Xeric Oak
-  Brazilian Pepper
-  Melaleuca
-  Temperate Hardwood
-  Tropical Hardwood
-  Live Oak
-  Cabbage Palm
-  Sand Live Oak
-  Hardwood Conifer Mixed
-  Australian Pine
-  Mixed Hardwoods
-  Streams & Waterways
-  Lakes > or = to 500 Acres
-  Lakes > or = to 10 Acres - < or = to 500 Acres
-  Lakes < or = to 10 Acres
-  Reservoirs > or = to 500 Acres
-  Reservoirs > or = to 100 Acres - < or = to 500 Acres
-  Reservoirs > or = to 10 Acres - < or = to 100 Acres
-  Reservoirs < or = to 10 Acres
-  Embayments Opening
-  Bay Swamps
-  Mangrove Swamps
-  Stream & Lake Swamps
-  Inland Ponds & Sloughs
-  Mixed Wetland Hardwoods
-  Willows
-  Mixed Shrubs
-  Cypress
-  Cypress - w/Wet Prairies
-  Cypress - Pine - Cabbage - Pine
-  Wetland Forested Mixed
-  Freshwater Marshes
-  Freshwater Sawgrass Marshes
-  Freshwater Cattail Marshes
-  Saltwater Marshes
-  Wet Prairies
-  Wet Prairies - with Pine
-  Emergent Aquatic Vegetation
-  Submergent Aquatic Vegetation
-  Sand Other Than Beaches
-  Rural Land In Transition
-  Borrow Areas
-  Spoil Areas
-  Fill Areas Highways & Railways
-  Airports
-  Roads & Highways
-  Canals & Locks
-  Auto Parking Facilities
-  Transmission Towers
-  Communication facilities
-  Electrical Power Facilities
-  Electrical Power Transmission
-  Water Supply Plants
-  Sewage Treatment

Land Use Data Source
1995 SFWMD Data Level 3



Figure IV.F.2
Ft. Myers Plant
Land Usage Legend

Copyright 1998 FPL All Rights Reserved

No expressed or implied warranties.
The materials contained herein may contain inaccuracies. The user is warned to utilize at his/her own risk and the user assumes risk of any and all loss. All Boundaries are approximate.





**Fort Myers Plant Site Plan
Showing Location of New Facility**

Figure IV.F.3

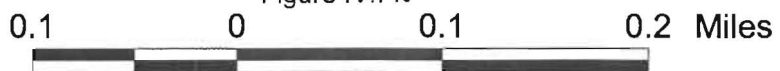

Ft Myers Plant Site

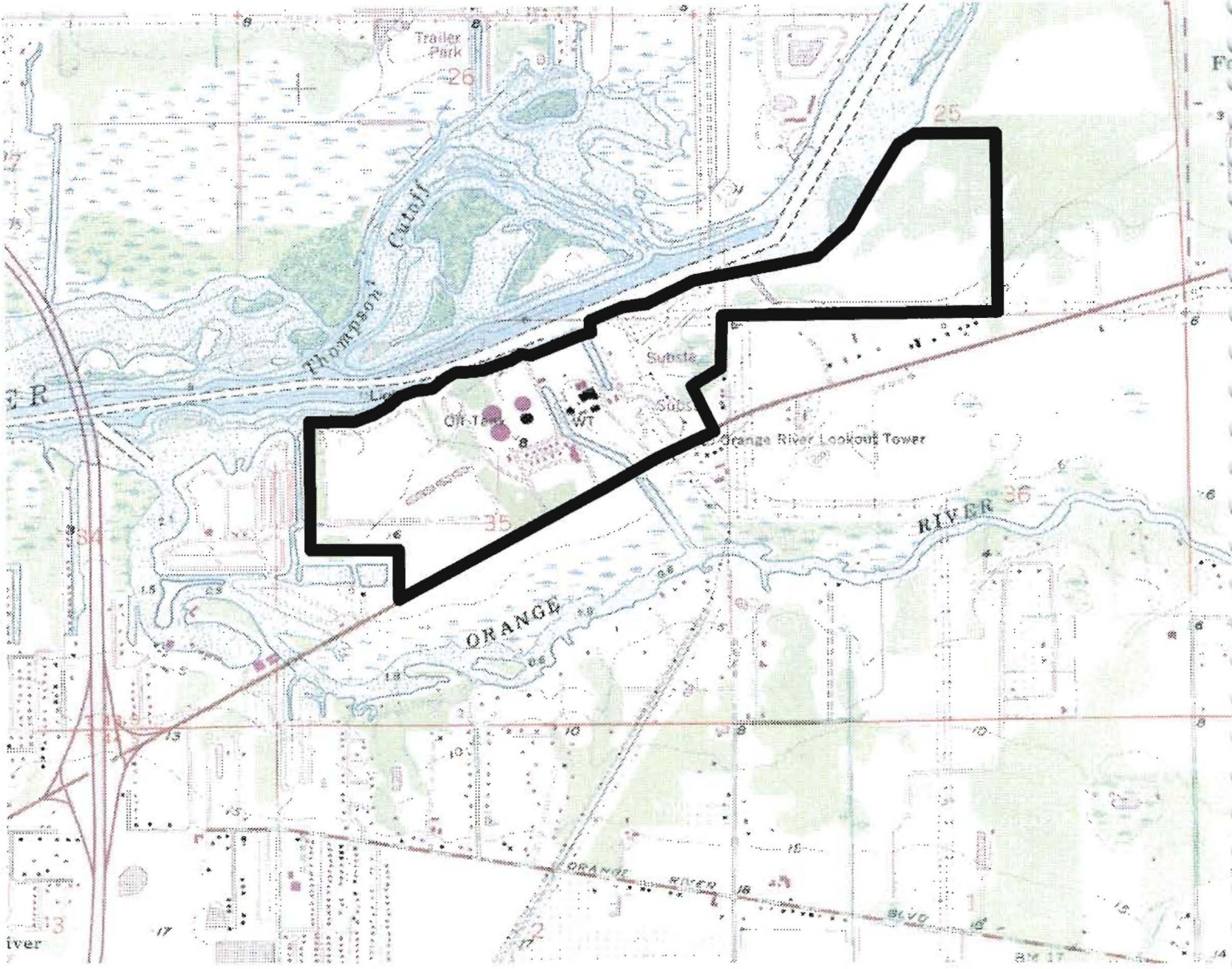

Figure IV.F. 3

146



Copyright 1998 FPL All Rights Reserved
No expressed or Implied warranties.
The materials contained herein may contain inaccuracies. The user is warned to utilize at his/her own risk and the user assumes risk of any and all loss. All Boundaries are approximate



***Environmental and Land Use Information:
Supplemental Information***

Preferred Site: Sanford Plant

(This page is left intentionally blank)

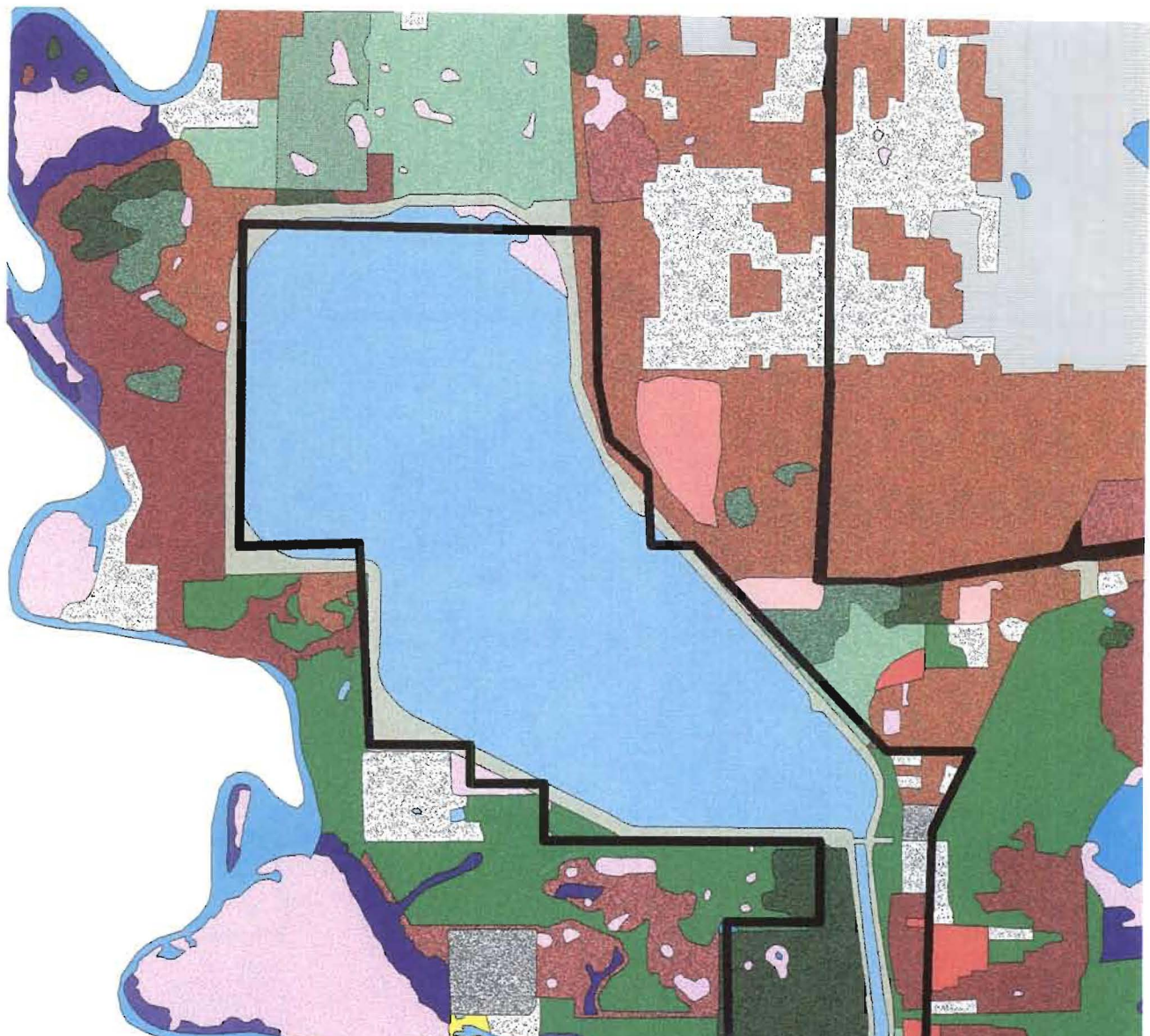

**Sanford Plant
Level 2 Land Use Legend:**

- Land Use Legend
- Residential Mobile Home Units
 - Residential Low Density
 - Residential Medium Density
 - Residential High Density
 - Commercial and Services
 - Industrial
 - Extractive
 - Institutional
 - Recreational
 - Open Land
 - Cropland and Pastureland
 - Tree Crops
 - Feeding Operations
 - Nurseries and Vineyards
 - Specialty Farms
 - Other Open Lands <Rural>
 - Herbaceous
 - Shrub and Brushland
 - Mixed Rangeland
 - Upland Coniferous Forests
 - Upland Hardwood Forests
 - Upland Hardwood Forests - Continued
 - Tree Plantations
 - Other Hardwoods

Legend Cont.

- Other Waterways
- Streams and Waterways
- Lakes
- Reservoirs
- Bays and Estuaries
- Other Wetlands
- Wetland Hardwood Forests
- Wetland Coniferous Forests
- Wetland Forested Mixed
- Vegetated Non-Forested Werlands
- Non-Vegetated
- Other Vegetation
- Beaches Other Than Swimming Beaches
- Sand Other Than Beaches
- Disturbed Lands
- Other Exposed Land
- Other Exposed Land
- Transportation
- Communications
- Utilities
- Other Utilities

Map Scale:

0.5 0 0.5 Miles

Land Use Data Source
1987 WMD Data Level 2



Figure IV.F.5
Sanford Plant Land Use
Level 2 Land Use
Last Revised 2/4/98

Copyright 1998 FPL All Rights Reserved
No expressed or implied warranties.
The materials contained herein may contain inaccuracies. The user is warned to utilize at his/her own risk and the user assumes risk of any and all loss. All Boundaries are approximate.



G:\land\flapltu.apr

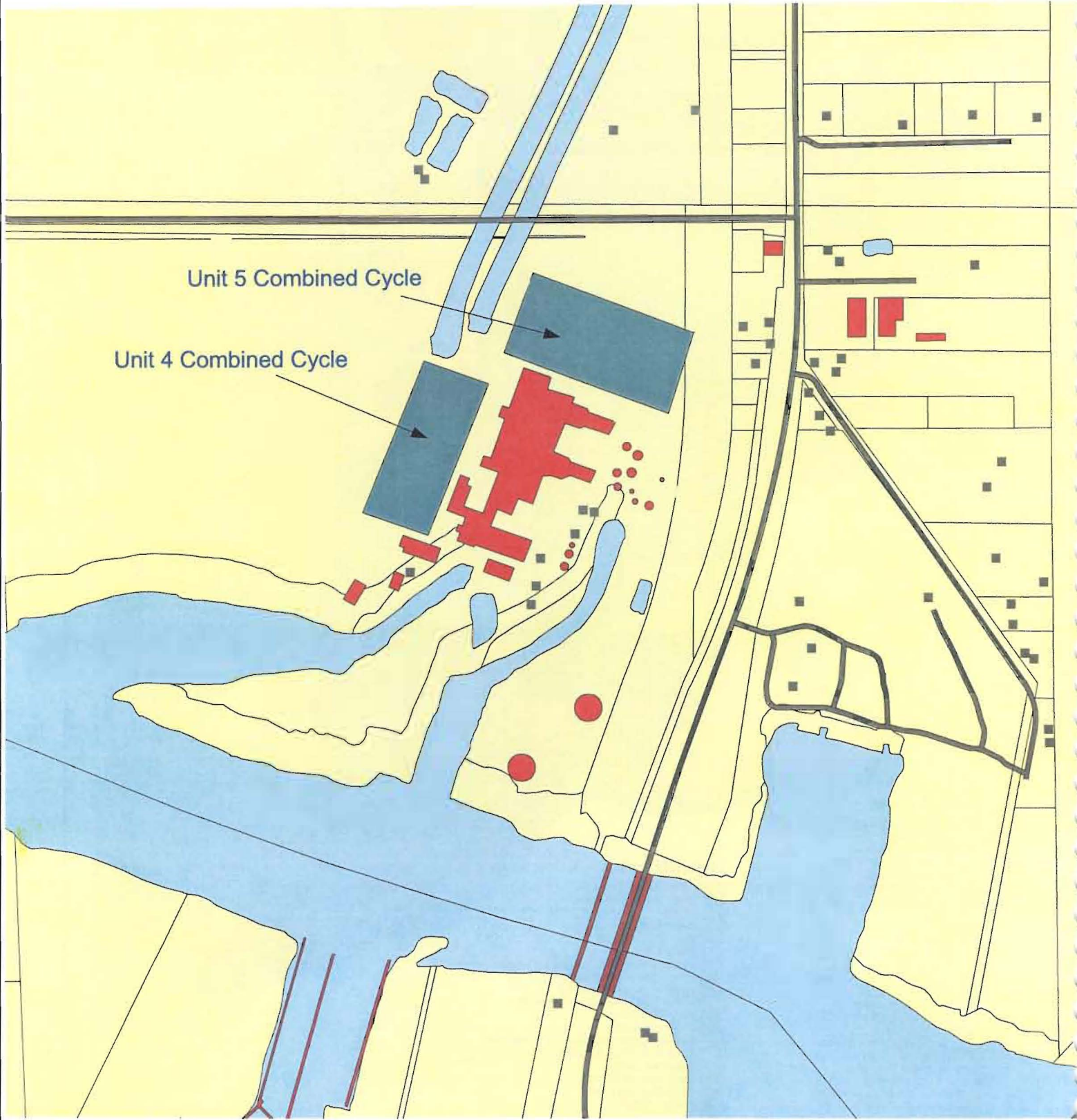

Figure IV.F.6

**Sanford Plant Site Plan
Showing Location of New Facility**



FPL Sanford Plant Site

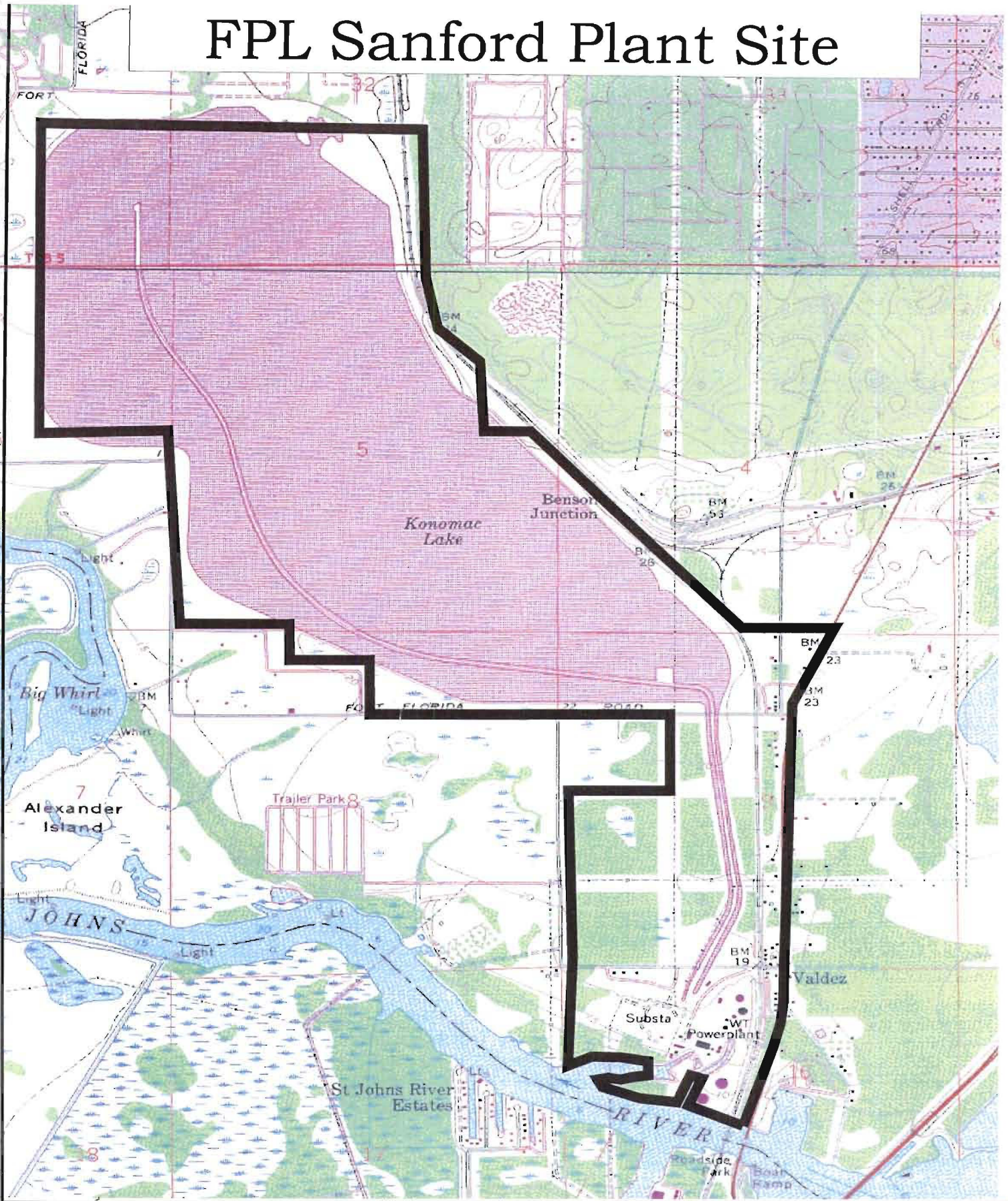

Figure IV F. 6



900 0 900 1800 Feet



151

Copyright 1998 FPL All Rights Reserved
No expressed or implied warranties.
The materials contained herein may contain inaccuracies. The user is warned to utilize at his/her own risk and the user assumes risk of any and all loss. All Boundaries are approximate.



(This page is left intentionally blank)

**IV. Environmental and Land Use Information:
Supplemental Information**

Preferred Site: Martin Plant

(This page is left intentionally blank)



Map Scale:



Land Use Data Source
1995 SFWMD Data Level 3



FPL



Figure IV.F.8
Martin Plant Land Use

Level 3 Land Use

Last Revised 2/4/98

Copyright 1998 FPL All Rights Reserved

No expressed or implied warranties.
The materials contained herein may contain inaccuracies. The user is warned to utilize at his/her own risk and the user assumes risk of any and all loss. All Boundaries are approximate.



G:\land\lta\phtu.apr

**Martin Plant
Level 3 Land Use Legend:**

- Land Usage Legend
- Mobile Homes
 - Fixed Single Family Units
 - Fixed Single Family Units 2-5 du/ac
 - Fixed & Mobile Units
 - Fixed Single Family Units
 - Multiple Dwelling Units Low Rise
 - Multiple Dwelling Units High Rise
 - Retail Sales & Service
 - Shopping Centers
 - Wholesale Sales & Service
 - Junkyards
 - Professional Services
 - Tourists Services
 - Oil & Gas Storage
 - Mixed Commercial & Services
 - Cemeteries
 - Food Processing
 - Other Light Industrial
 - Other Heavy Industrial
 - Strip Mines
 - Sand & Gravel Pits
 - Rock Quarries
 - Educational Facilities
 - Religious
 - Medical & Health Care
 - Governmental
 - Correctional
 - Other Institutional
 - Commercial Child Care
 - Swimming Beach
 - Golf Courses
 - Marinas & Fish Camps
 - Parks & Zoos
 - Community Recreational Facilities
 - Historical Sites
 - Other Recreational
 - Undeveloped Land Within Urban Areas
 - Inactive Land with Street Pattern
 - Urban Land In Transaction
 - Other Open Land
 - Improved Pastures
 - Unimproved Pastures
 - Woodland Pastures
 - Row Crops
 - Field Crops
 - Sugar Cane Fields
 - Citrus Groves
 - Tree Nurseries
 - Sod Farms
 - Ornamentals
 - Floriculture
 - Horse Farms
 - Dairies
 - Aquaculture
 - Fallow Crop Land
 - Herbaceous Rangeland
 - Palmetto Prairies
 - Coastal Scrub
 - Other Scrubs & Brush
 - Mixed Rangeland
 - Pine Flatwoods
 - Melaleuca Infested
 - Longleaf Pine - Xeric Oak
 - Sand Pine
 - Pine - Mesic Oak
 - Xeric Oak
 - Brazilian Pepper
 - Melaleuca
 - Temperate Hardwood

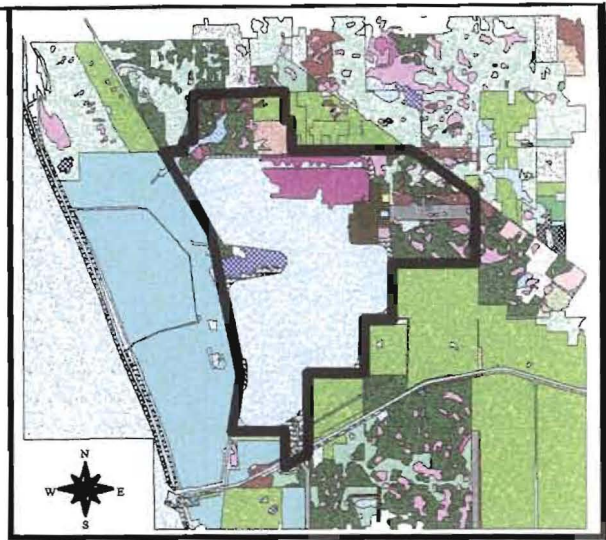

Legend Cont.

- Tropical Hardwood
- Live Oak
- Cabbage Palm
- Sand Live Oak
- Hardwood Conifer Mixed
- Australian Pine
- Mixed Hardwoods
- Streams & Waterways
- Lakes > or = to 500 Acres
- Lakes > or = to 10 Acres - < or = to 500 Acres
- Lakes < or = to 10 Acres
- Reservoirs > or = to 500 Acres
- Reservoirs > or = to 100 Acres - < or = to 500 Acres
- Reservoirs > or = to 10 Acres - < or = to 100 Acres
- Reservoirs < or = to 10 Acres
- Embayments Opening
- Bay Swamps
- Mangrove Swamps
- Stream & Lake Swamps
- Inland Ponds & Sloughs
- Mixed Wetland Hardwoods
- Willows
- Mixed Shrubs
- Cypress
- Cypress - with Wet Prairies
- Cypress - Pine - Cabbage - Pine
- Wetland Forested Mixed
- Freshwater Marshes
- Freshwater Sawgrass Marshes
- Freshwater Cattail Marshes
- Saltwater Marshes
- Wet Prairies
- Wet Prairies - with Pine
- Emergent Aquatic Vegetation
- Submergent Aquatic Vegetation
- Sand Other Than Beaches
- Rural Land In Transition
- Borrow Areas
- Spoil Areas
- Fill Areas Highways & Railways
- Airports
- Roads & Highways
- Canals & Locks
- Auto Parking Facilities
- Transmission Towers
- Communication Facilities
- Electrical Power Facilities
- Electrical Power Transmission
- Water Supply Plants
- Sewage Treatment

Land Use Data Source
1995 SFWMD Data Level 3



Figure IV.F.9
Martin Plant Land Use

Level 3 Land Use Legend
Last Revised 2/4/98

Copyright 1998 FPL All Rights Reserved

No expressed or Implied warranties
The materials contained herein may contain inaccuracies. The user is warned to utilize at his/her own risk and the user assumes risk of any and all loss. All Boundaries are approximate.



G:\land\fig\fig11u.apr

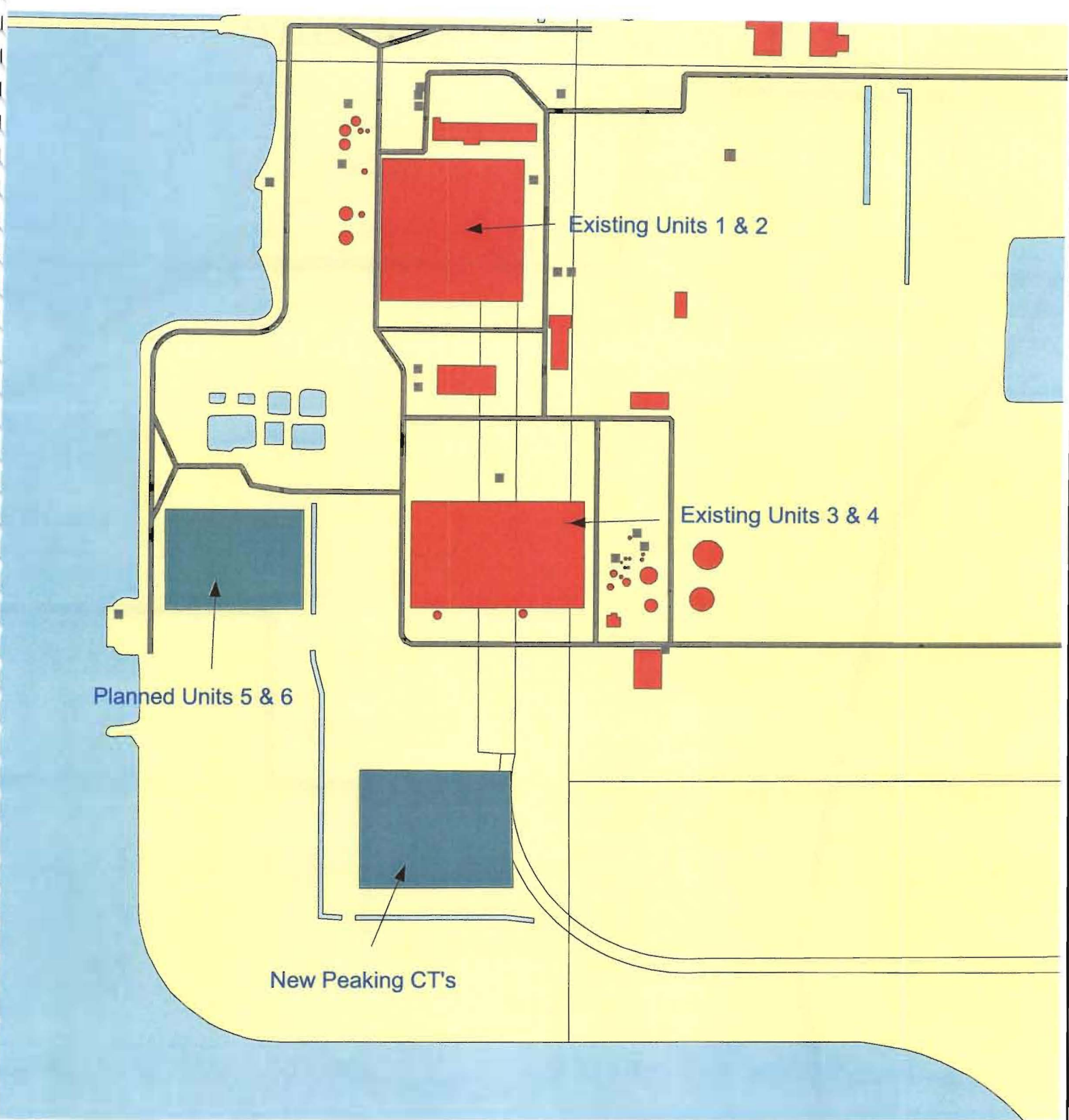

Figure IV.F.10

**Martin Plant Site Plan
Showing Location of New Facility**



0.1 0 0.1 0.2 Miles



FPL Martin Plant Site

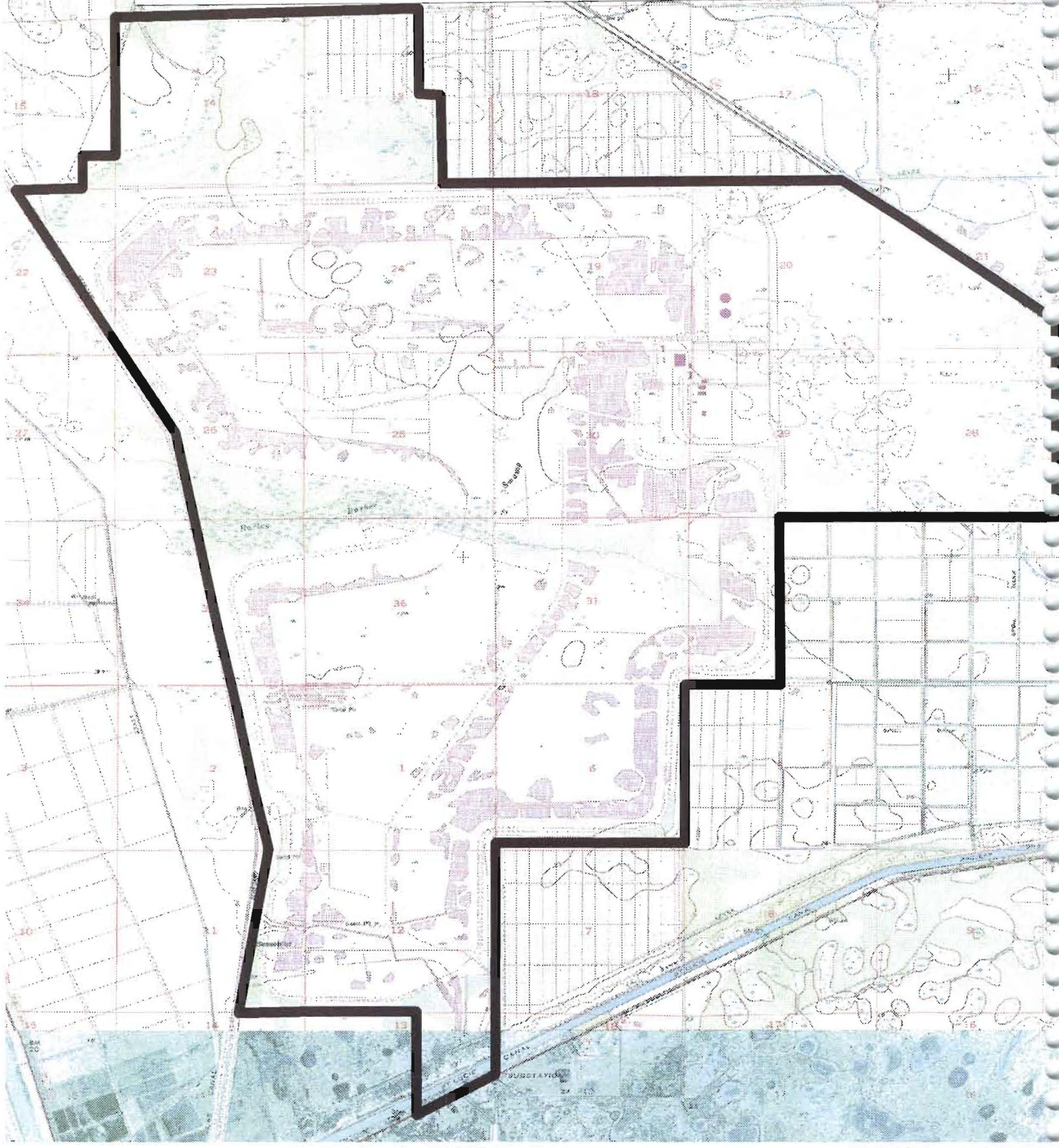

Figure IV.F.11

158



Copyright 1998 FPL All Rights Reserved
No expressed or implied warranties.
The materials contained herein may contain inaccuracies. The user is warned to utilize at his/her own risk and the user assumes risk of any and all loss. All boundaries are approximate



***Environmental and Land Use Information:
Supplemental Information***

Preferred Site: Midway Plant

(This page is left intentionally blank)

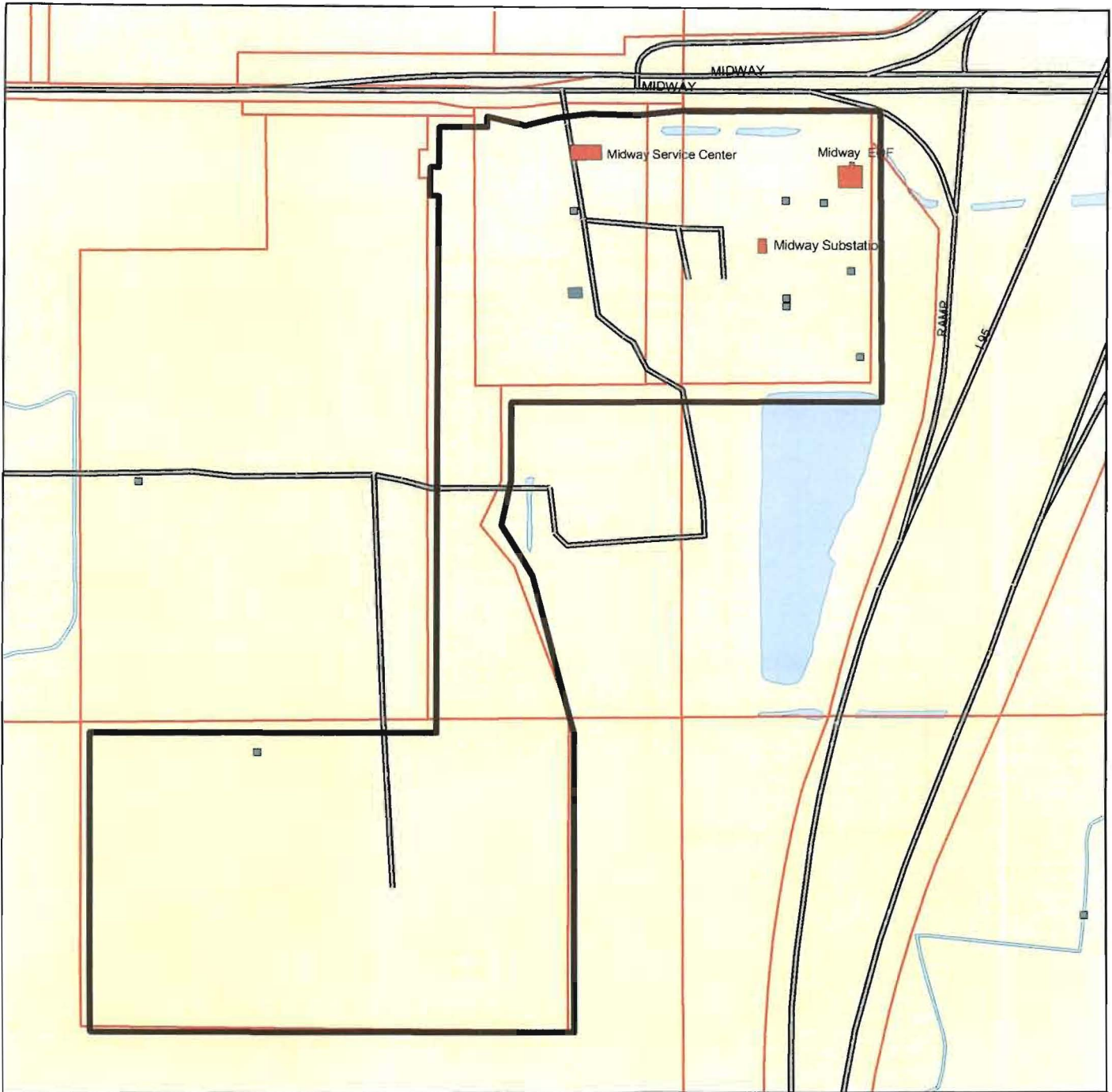

Midway Site



Copyright 2001 FPL All Rights Reserved.
 No expressed or Implied warranties.
 The materials contained herein may contain inaccuracies. The user is warned to utilize at his/her own risk and the user assumes risk of any and all loss. All Boundaries are approximate.



Figure IV.F.12

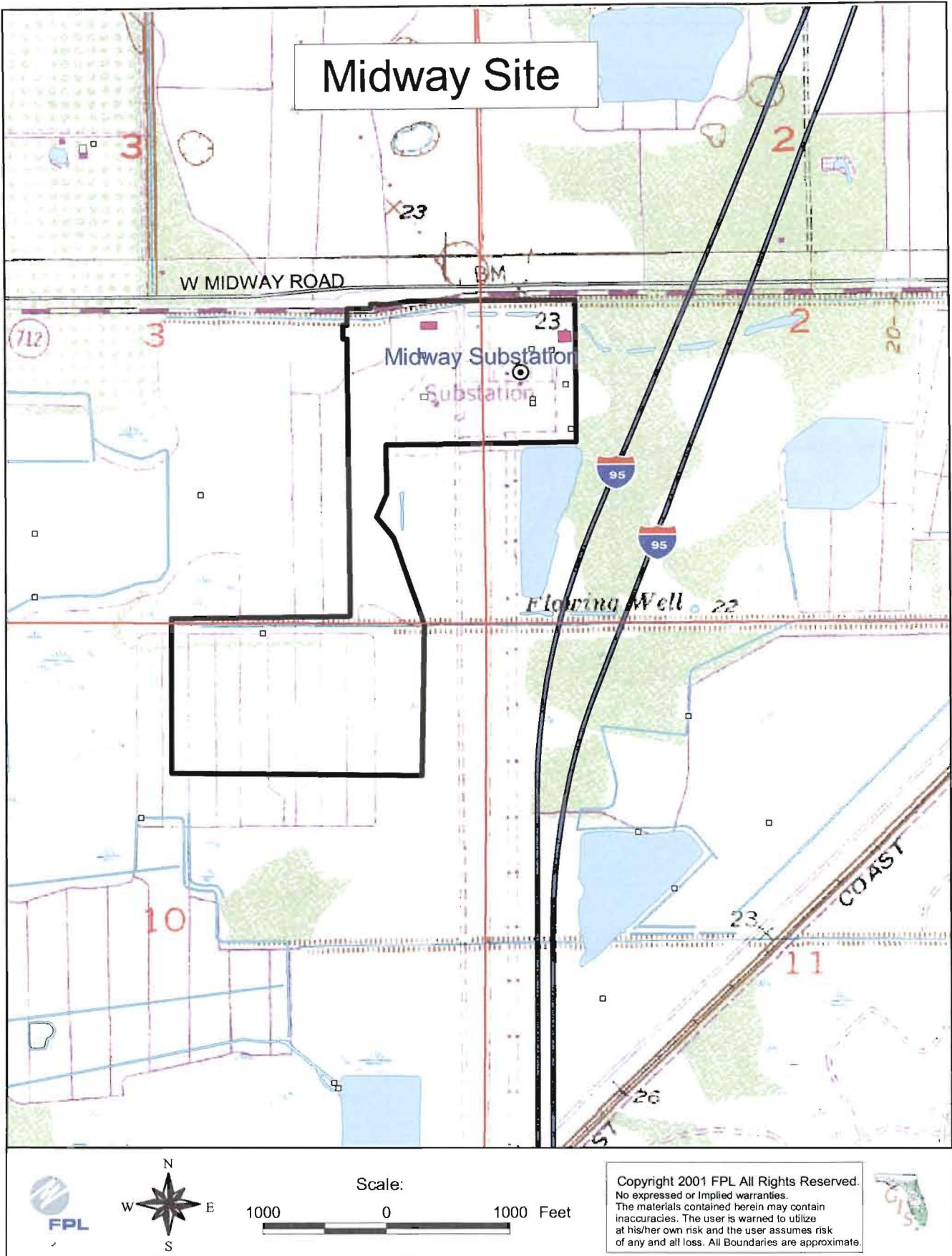

Figure IV.F.13
162

***Environmental and Land Use Information:
Supplemental Information***

Potential Sites

(This page is left intentionally blank)

FPL Port Everglades Plant Site

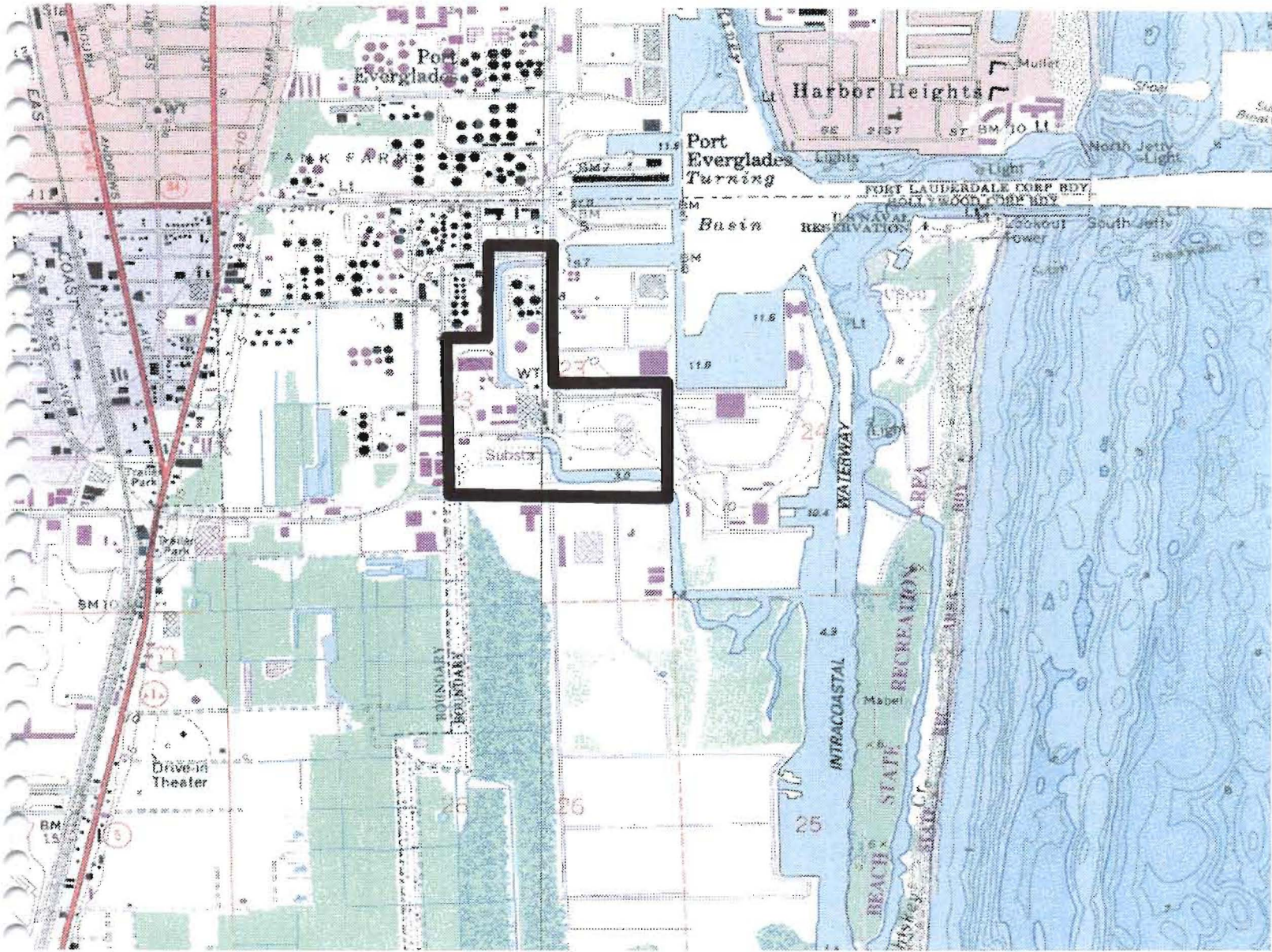
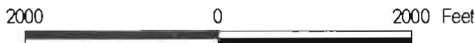

Figure IV.F.14

165



Copyright 1998 FPL All Rights Reserved
No expressed or implied warranties.
The materials contained herein may contain inaccuracies. The user is warned to utilize at his/her own risk and the user assumes risk of any and all loss. All Boundaries are approximate.



FPL Canaveral Plant Site

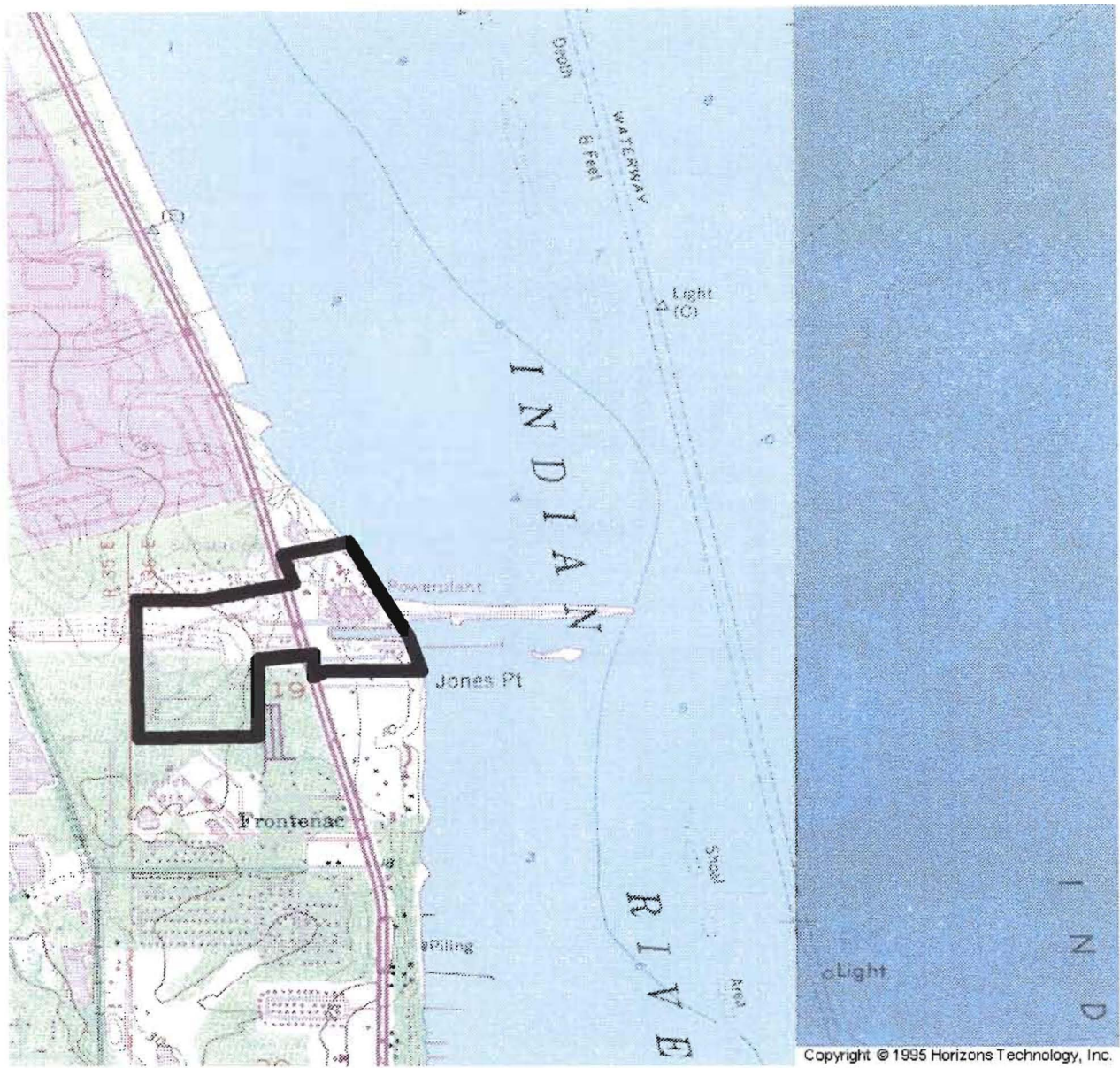
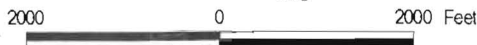

Figure IV.F.15

166



Copyright 1998 FPL All Rights Reserved
No expressed or Implied warranties.
The materials contained herein may contain inaccuracies. The user is warned to utilize at his/her own risk and the user assumes risk of any and all loss. All Boundaries are approximate.



FPL Riviera Plant Site

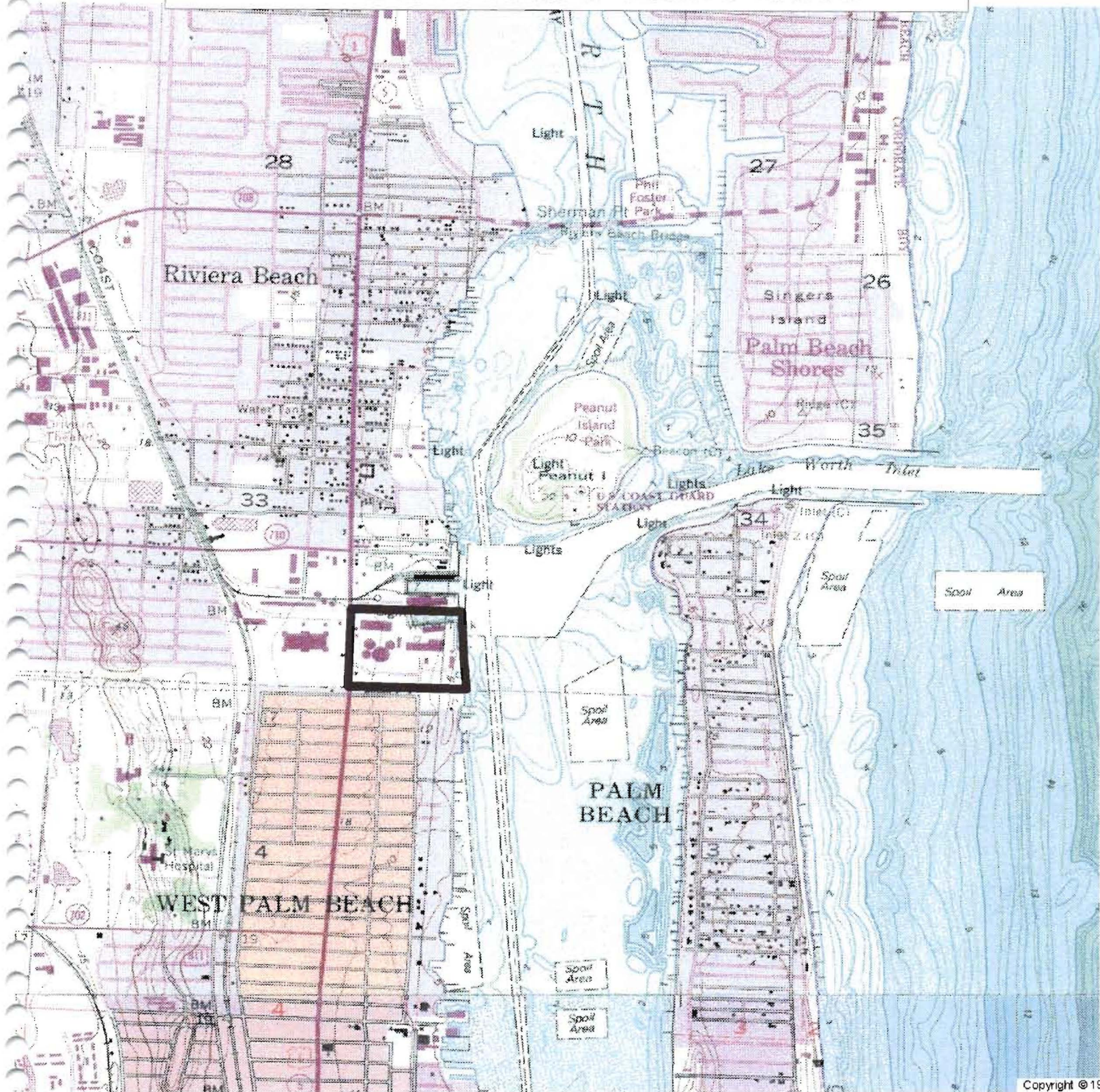

Copyright © 1998

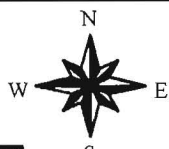

2000 0 2000 Feet

Figure IV.F.16

167

Copyright 1998 FPL All Rights Reserved

No expressed or implied warranties. The materials contained herein may contain inaccuracies. The user is warned to utilize at his/her own risk and the user assumes risk of any and all loss. All Boundaries are approximate.



(This page is left intentionally blank)

CHAPTER V

Other Planning Assumptions & Information

(This page is left intentionally blank.)

Introduction

The Florida Public Service Commission (FPSC), in Docket No. 960111-EU, specified certain information that was to be included in an electric utility's Ten Year Power Plant Site Plan filing. Among this specified information was a group of 12 items listed under a heading entitled "Other Planning Assumptions and Information". These 12 items basically concern specific aspects of a utility's resource planning work. The FPSC requested a discussion or a description of each of these items.

These 12 items are addressed individually below as separate "Discussion Items".

Discussion Item # 1: Describe how any transmission constraints were modeled and explain the impacts on the plan. Discuss any plans for alleviating any transmission constraints.

FPL's resource planning considers two type of transmission constraints. External constraints deal with FPL's ties to its neighboring systems. Internal constraints deal with the flow of electricity within the FPL system.

The external constraints are important since they affect the development of assumptions for the amount of external assistance which is available and the amount and price of economy energy purchases. Therefore, these external constraints are incorporated both in the reliability analysis and economic analysis aspects of resource planning. The amount of external assistance which is assumed to be available is based on the transfer capability as well as historical levels of available assistance. FPL models this amount of external assistance as an additional generator within FPL's system which provides capacity in all but the peak load months. The assumed amount and price of economy energy are based on historical values and projections from production costing models.

Internal transmission constraints or limitations are addressed in developing the costs for siting new units at different locations. Site-specific transmission costs are developed for each different unit/unit location option.

Discussion Item # 2: Discuss the extent to which the overall economics of the plan were analyzed. Discuss how the plan is determined to be cost-effective. Discuss any changes in the generation expansion plan as a result of sensitivity tests to the base case load forecast.

As discussed in Chapter III of this document, FPL performs economic analyses of competing resource plans using the EGEAS (Electric Generation Expansion Analysis System) computer model from the Electric Power Research Institute (EPRI) and Stone and Webster Management Consultants, Inc. The resource plan reflected in this document emerged as the resource plan with the least impact on FPL's levelized system average electric rates (i.e., a Rate Impact Measure or RIM approach) and on the present value of revenue requirements for the FPL system.⁷

FPL performed three sensitivity analyses as part of its 2000 resource planning work or in preparation for this site plan filing. One of these analyses used a load forecast which differed from FPL's base case or "Most Likely" load forecast. (The other two sensitivity analyses are discussed in Discussion Items # 4 and # 6.)

The first sensitivity analysis examined a case in which a "High Load" forecast was combined with a "Low Price" fuel forecast. In this case, FPL's need for incremental resources moved forward in time to the year **2001**. This accelerated need, if assumed to be met solely through the construction of new units (as is the primary focus of the Site Plan filing), could only be addressed by combustion turbines or new purchases in the early years. Subsequent years would likely be addressed by new combined cycle units.

In its 2000 resource planning work, FPL did not conduct a sensitivity case involving a "Low Load" forecast. Since the system reliability analysis which utilized the "Most Likely" load forecast showed that new units were not needed until 2005, it was clear that a "Low Load" case would not have shown a power plant decision needed prior to 2005. Therefore, FPL saw no value in analyzing such a "Low Load" case in its 2000 planning work.

The construction - only options selected in the resource plans (purchase options are not shown) for FPL's "Most Likely" case, and for the first sensitivity case discussed above, are presented on the following page in Table V.1.

⁷ FPL's basic approach in its resource planning work is to base decisions on a lowest electric rate basis. However, when DSM levels are considered a "given" in the analysis, the lowest rate basis and the lowest system revenue requirements basis are identical. In such cases (as in FPL's 2000 resource planning work), FPL evaluates options on the simpler - to - calculate (but equivalent) lowest system revenue requirements basis.

Table V.1

**Selected Power Plant Construction Options For
Base and Sensitivity Cases**

Year	"Most Likely" Load and "Most Likely" Fuel Price Base Case	"High" Load and "Low" Fuel Price Scenario Case
2000	----	----
2001	2 CT's at Martin Ft. Myers Repowering: Initial Phase	2 CT's at Martin Ft. Myers Repowering: Initial Phase 3 Unsited CT's
2002	Ft. Myers Repowering: Second Phase Sanford Repowering: Initial Phase	Ft. Myers Repowering: Second Phase Sanford Repowering: Initial Phase
2003	Sanford Repowering: Second Phase 2 CT's at Ft. Myers	Sanford Repowering: Second Phase 2 CT's at Ft. Myers
2004	----	----
2005	Martin Unit # 5 Midway Unit # 1 Fort Myers Combustion Turbine Conversion Martin Combustion Turbine Conversion	Martin Unit # 5 Midway Unit # 1 Fort Myers Combustion Turbine Conversion Martin Combustion Turbine Conversion Martin Unit # 6
2006	Martin Unit # 6	Unsited CC Unit # 1
2007	Unsited CC Unit # 1	Unsited CC Unit # 2
2008	----	Unsited CC Unit # 3
2009	Unsited CC Unit # 2	Unsited CC Unit # 4
2010	Unsited CC Unit # 3 Unsited CC Unit # 4 Unsited CC Unit # 5	Unsited CC Unit # 5 Unsited CC Unit # 6

Key: CT = Combustion Turbine
CC = Combined Cycle Unit

Discussion Item # 3: Explain and discuss the assumptions used to derive the base case fuel forecast. Explain the extent to which the utility tested the sensitivity of the base case plan to high and low fuel price scenarios. If high and low fuel price sensitivities were performed, explain the changes made to the base case fuel price forecast to generate the sensitivities. If high and low fuel price scenarios were performed as part of the planning process, discuss the resulting changes, if any, in the generation expansion plan under the high and low fuel price scenario. If high and low fuel price sensitivities were not evaluated, describe how the base case plan is tested for sensitivity to varying fuel prices.

The basic assumptions FPL used in deriving its base case or "Most Likely" fuel price forecast are discussed in Chapter III of this document.

The "High Price" and "Low Price" fuel forecasts are developed based on a review of major supply and demand assumptions for oil and natural gas. The "High Price" forecast assumes that the worldwide demand for petroleum products will grow somewhat rapidly throughout the planning horizon. Non-OPEC crude oil supply will remain unchanged as improved drilling technology permits only the replacement of depleting fields. As a result, OPEC's market share will grow more rapidly than in the base case which would result in higher oil prices. In addition, this forecast assumes that domestic natural gas demand will grow somewhat rapidly, primarily due to significant increases in the construction of combined cycle generation. Domestic natural gas production will increase slowly as improved drilling technology permits only the replacement of depleting fields. This will result in higher natural gas imports, including Liquefied Natural Gas (LNG), than in the base case which, in turn, results in higher natural gas prices.

The "Low Price" fuel forecast assumes that worldwide demand for petroleum products will grow slowly over the forecast horizon. It also assumes that non-OPEC crude oil supply will grow rapidly due to significant improvement in drilling technology and that OPEC's market share will only make small gains relative to the base case. In regard to natural gas, the "Low Price" forecast assumes that domestic demand for natural gas will grow slowly over the forecast horizon and that domestic production will increase faster than in the base case. These assumptions result in lower oil and gas price forecasts.

FPL did test the sensitivity of its resource plan to a "Low Price" fuel forecasts in conjunction with a "High Load" forecast. The results of these analyses are presented above in FPL's

response to Discussion Item # 2. FPL did not test the sensitivity of its resource plan to a "High Price" fuel forecast in its 2000 IRP work. Although FPL typically performs a sensitivity analysis on a combined "Low Load"/ "High Price" fuel forecast, such an analysis would not have shown a need for new power plants before 2005 (as discussed in Discussion Item #2.) Consequently, this analysis was not performed in FPL's 2000 planning work.

Discussion Item # 4: Describe how the sensitivity of the plan was tested with respect to holding the differential between oil/gas and coal constant over the planning horizon.

In addition to the sensitivity analyses discussed above which examined the impact of "High Load" and "Low Price" fuel forecasts, FPL also performed a sensitivity analysis in which the differentials between oil prices, gas prices, and coal prices were kept constant over the planning horizon. FPL performed this analysis solely due to the fact that it was included in the FPSC's list of specified information for the Site Plan filing. FPL believes that the likelihood of a constant differential between fuel prices occurring over the planning horizon is very small. In order to perform this "acid test" analysis, FPL used the initial year price forecast for each fuel and kept those prices constant throughout the planning horizon

The results of this scenario analysis were identical to that of the Base Case.

Discussion Item # 5: Describe how generating unit performance was modeled in the planning process.

The performance of existing generating units on FPL's system was modeled using current projections for scheduled outages, unplanned outages, and capacity output ratings and heat rate information. Schedules 1 and 8 present the capacity output ratings of FPL's existing units. The values used for outages and heat rates are consistent with the values FPL has used in planning studies in recent years.

In regard to new unit performance, FPL utilized current projections for the capital costs, fixed and variable operating & maintenance costs, capital replacement costs, construction schedules, heat rates, and capacity ratings for all construction options which were considered in the resource planning work. A summary of this information for the new capacity options FPL projects to add over the planing horizon is presented on Schedule 9. Please refer to that schedule.

Discussion Item # 6: Describe and discuss the financial assumptions used in the planning process. Discuss how the sensitivity of the plan was tested with respect to varying financial assumptions.

The key financial assumptions used in FPL's 2000 resource planning work were 45% debt and 55% equity FPL capital structure; projected debt cost of 7.6%; and an equity return of 11.8%. These assumptions resulted in a weighted average cost of capital of 9.9% and an after-tax discount rate of 8.6%. These assumptions were used in FPL's base case or "Most Likely" forecast case analysis, and in its sensitivity analyses of alternate load and/or fuel price forecasts.

In order to test the sensitivity of the resource plan to a different set of financial assumptions, FPL performed an analysis in which the capital financing structure was changed to one which might be more typical of a case involving third-party financing of a new power plant. This alternate financing structure was assumed to be one made of 80% debt and 20% equity. The returns on debt and equity were assumed to be the same as for FPL's "Most Likely" case 7.6% and 11.8% respectively. These assumptions result in a weighted average cost of capital of 8.4% and an after-tax discount rate of 6.1%.

The results of this "alternate financial case" sensitivity analysis were the same as for FPL's "Most Likely" or Base Case analysis.

Discussion Item # 7: Describe in detail the electric utility's Integrated Resource Planning process. Discuss whether the optimization was based on revenue requirements, rates, or total resource cost.

FPL's integrated resource planning (IRP) process is described in detail in Chapter III of this document.

The standard basis for comparing the economics of competing resource plans in FPL's basic IRP process is the impact of the plans on FPL's electricity rate levels with the intent of minimizing FPL's levelized system average rate (i.e., a Rate Impact Measure or RIM approach). However, in its 2000 planning work FPL utilized a net present value of system revenue requirements as the basis for comparing options and plans. (As discussed in response to Discussion Item # 2, both the electricity rate basis and the system revenue requirement basis are identical when DSM levels are unchanged between competing plans. Such was the case in FPL's 2000 planning work.)

Discussion Item # 8: Define and discuss the electric utility's generation and transmission reliability criteria.

FPL traditionally uses two generation reliability criteria in its resource planning work. These are a minimum 15% Summer and Winter reserve margin and a maximum of 0.1 days per year loss-of-load-probability (LOLP). However, in its 2000 planning work, FPL also used a third criterion: a minimum 20% Summer and Winter reserve margin which applies starting with the Summer of 2004. This new criterion was the result of an agreement reached between FPL, FPC, TECO, and FPSC in Docket No. 981890-EU. These reliability criteria are discussed in Chapter III of this document. Please refer to that chapter.

In regard to transmission reliability, FPL has adopted transmission planning criteria that are consistent with the planning criteria established by the Florida Reliability Coordinating Council (FRCC). The FRCC has adopted transmission planning criteria that are consistent with the planning criteria established by the North American Electric Reliability Council (NERC) in its *Planning Standards*. FPL has applied these planning criteria in a manner consistent with prudent utility practice. The *NERC Planning Standards* are available on the internet (<http://www.nerc.com/~filez/pss-psg.html>).

In addition, FPL has developed a Facility Connection Requirements (FCR) document as well as a Facility Rating Methodology document that are also available on the internet (http://www.enx.com/FPL/fpl_home.html).

Thermal ratings for specific transmission lines or transformers are found in the load flow cases that are available on the internet (http://www.enx.com/FPL/fpl_home.html). The normal voltage criteria for FPL stations is given below:

<u>Voltage Level (kV)</u>	<u>Vmin (p.u.)</u>	<u>Vmax (p.u.)</u>
69, 115, 138, 500	0.95	1.05
230	0.95	1.06

There may have been isolated cases for which FPL may have determined it prudent to deviate from the general criteria stated above. The overall potential impact on customers, the probability of an outage actually occurring, as well as other factors may have influenced the decision in such cases.

Discussion Item # 9: Discuss how the electric utility verifies the durability of energy savings for its DSM programs.

The impact of FPL's DSM Programs on demand and energy consumption is evaluated over time. Data is collected from non-participants in order to establish a non-DSM technology baseline. Participants' data is compared against non-participants' data to establish usage patterns, demand impacts and to validate engineering assumptions.

FPL utilizes any or all of three major impact evaluation analysis methods in a manner that most cost-effectively meets the overall impact evaluation objectives. These three major impact evaluation analysis methods are: engineering analysis, statistical billing analysis, and on-site metering research. As DSM evaluations proceed over time, the components to be analyzed and the periods for which data is available will increase, resulting in continual enhancements in the scope and accuracy of reported evaluation results.

Finally, for those DSM measures which involve the utilization of load management, FPL conducts periodic tests of the load control equipment to ensure that it is functioning correctly.

Discussion Item # 10: Discuss how strategic concerns are incorporated in the planning process.

FPL's resource planning process is designed to address various "strategic concerns" or areas of uncertainty. There are 6 areas of uncertainty that FPL seeks to address in its resource planning work: load growth, fuel price, transmission system constraints, environmental regulations, evolving technology, and competitive risk.

In regard to uncertainty about both load growth and fuel price, FPL addressed this by developing a resource plan which used a combination of a "High Load" forecast and a "Low Price" fuel forecast, as is discussed in Discussion Item # 3. (In response to the list of information specified by the FPSC for inclusion in the Site Plan filing, FPL also developed a resource plan which used an "acid test" fuel price forecast. This is discussed in regard to Discussion Item # 4.) In addition, uncertainty about fuel prices is addressed in fuel conversion efforts such as repowering projects now planned at FPL's Fort Myers and

Sanford sites and in retaining the capability to burn more than one fuel in a number of FPL generating units.

Uncertainty regarding transmission system constraints is addressed by annually updating assumptions about how much assistance may be available to FPL from outside FPL's service territory as well as assumptions relating to transmission constraints within FPL's system. In regard to uncertainty about environmental regulations, FPL's policy has always been that it will comply with all existing environmental laws and regulations. In that regard, FPL's resource planning analyses include all reasonably known costs of complying with these laws and regulations. Furthermore, in regard to potential new environmental regulations, FPL believes that its efforts to maintain the ability to burn varying grades of oil or burning either oil or natural gas at numerous plants, and to expand the use of natural gas (through the planned repowering projects at Fort Myers and Sanford, and the planned addition of new natural gas-fired combined cycle units), should allow FPL to reasonably respond to a variety of potential environmental regulations.

Uncertainty about evolving technology's potential impact on resource plans is best addressed by not committing to resource additions before it is necessary to do so. (In most cases, this approach also benefits the economics of the resource plan.) This minimizes the chance that a newly emerged technology will turn out to be a more economical choice than what the utility has already committed to. Uncertainty about evolving technology is also reduced by maintaining close contact with equipment vendors in order to better understand what the developmental status is of various generating technologies.

Finally, an increasingly important consideration in FPL's planning process is that of competitive risk. FPL's resource planning process is designed to identify the resource plan which best minimizes system average electric rates in order to keep FPL's service competitive in the evolving utility industry. Also, because of the inherent uncertainty associated with an evolving industry, long-term purchase commitments are undesirable. FPL seeks to avoid/minimize such commitments in its planning.

Discussion Item # 11: Describe the procurement process the electric utility intends to utilize to acquire the additional supply-side resources identified in the electric utility's ten-year site plan.

As has been discussed, the near - term elements of FPL's capacity additions are the repowering of its Fort Myers and Sanford plants, the addition of new combustion turbines (CT's) at Martin and Fort Myers (which will later be converted into CC units), and a number of firm capacity, short-term purchases. The incremental capacity from the two repowering projects comes from the addition of new CT's and heat recovery steam generators (HRSG's). FPL is acquiring the repowering-related CT's, plus the other CT's for Martin and Fort Myers, and the HRSG's through a bid process which will combine cost and performance considerations. The firm capacity short-term purchases are being acquired through negotiations.

The later capacity additions projected in FPL's Site Plan document will likely be carried out following the issuance of a capacity solicitation to potential suppliers at an appropriate time, if that approach represents the best vehicle to offer the lowest cost new generating capacity. FPL notes that its experience in 2000 in obtaining transmission cost estimates (after the FERC – required separation of its transmission planning group) leads FPL to question whether a solicitation process can still provide total cost estimates to a meaningful number of parties in the relatively short time a solicitation decision will be needed.

Discussion Item # 12: Provide the transmission construction and upgrade plans for electric utility system lines that must be certified under the Transmission Line Siting Act (403.52 – 403.536, F. S.) during the planning horizon. Also, provide the rationale for any new or upgraded line.

FPL's plans do not include any new or upgraded transmission lines during the 2001 – 2010 time period which would need to be certified under the Transmission Line Siting Act (403.52 – 403.536, F.S.)

(This page is left intentionally blank.)

CHAPTER VI

Summary of Required Schedules

(This page is left intentionally blank.)

Schedule 1

**Existing Generating Facilities
As of December 31, 2000**

(1)	(2)	(3)	(4)	(5)	(6)	(7)	(8)	(9)	(10)	(11)	(12)	(13)	(14)
Plant Name	Unit No	Location	Unit Type	Fuel		Transport		Fuel Days Use	Commercial In-Service Month/Year	Expected Retirement Month/Year	Gen Max Nameplate KW	Net Capability 1/	
				Pri	Alt	Pri	Alt	Use				Summer MW	Winter MW
Turkey Point		Dade County 27/57S/40E									2,338,100	2,208	2,260
	1		ST	FO6	NG	WA	PL	Unknown	Apr-67	Unknown	402,050	410	411
	2		ST	FO6	NG	WA	PL	Unknown	Apr-68	Unknown	402,050	400	403
	3		NP	UR	No	TK	No	Unknown	Nov-72	Unknown	760,000	693	717
	4		NP	UR	No	TK	No	Unknown	Jun-73	Unknown	760,000	693	717
	1-5		IC	FO2	No	TK	No	Unknown	Dec-67	Unknown	14,000	12	12
Cutler		Dade County 27/55S/40E									236,500	215	217
	5		ST	NG	No	PL	No	Unknown	Nov-54	Unknown	74,500	71	72
	6		ST	NG	No	PL	No	Unknown	Jul-55	Unknown	162,000	144	145
Lauderdale		Broward County 30/50S/42E									1,863,972	1,694	1,952
	4		CC	NG	FO2	PL	PL	Unknown	Oct-57	Unknown	521,250	427	467
	5		CC	NG	FO2	PL	PL	Unknown	Apr-58	Unknown	521,250	427	467
	1-12		GT	NG	FO2	PL	PL	Unknown	Aug-70	Unknown	410,736	420	509
	13-24		GT	NG	FO2	PL	PL	Unknown	Aug-72	Unknown	410,736	420	509
Port Everglades		City of Hollywood 23/50S/42E									1,665,086	1,662	1,757
	1		ST	FO6	NG	WA	PL	Unknown	Jun-60	Unknown	225,250	221	222
	2		ST	FO6	NG	WA	PL	Unknown	Apr-61	Unknown	225,000	221	222
	3		ST	FO6	NG	WA	PL	Unknown	Jul-64	Unknown	402,050	390	392
	4		ST	FO6	NG	WA	PL	Unknown	Apr-65	Unknown	402,050	410	412
	1-12		GT	NG	FO2	PL	PL	Unknown	Aug-71	Unknown	410,736	420	509

1/ These ratings are peak capability

Schedule 1

**Existing Generating Facilities
As of December 31, 2000**

(1)	(2)	(3)	(4)	(5)	(6)	(7)	(8)	(9)	(10)	(11)	(12)	(13)	(14)
Plant Name	Unit No.	Location	Unit Type	Fuel		Transport		Fuel Days Use	Commercial In-Service Month/Year	Expected Retirement Month/Year	Gen Max Nameplate KW	Net Capability 1/	
				Pri	Alt	Pri	Alt					Summer MW	Winter MW
Riviera		City of Riviera Beach 33/42S/43E									<u>620,840</u>	<u>563</u>	<u>565</u>
	3		ST	FO6	NG	WA	PL	Unknown	Jun-62	Unknown	310,420	283	283
	4		ST	FO6	NG	WA	PL	Unknown	Mar-63	Unknown	310,420	280	282
Martin		Martin County 29/29S/38E									<u>2,950,000</u>	<u>2,588</u>	<u>2,674</u>
	1		ST	NG	FO6	PL	PL	Unknown	Dec-80	Unknown	863,000	824	843
	2		ST	NG	FO6	PL	PL	Unknown	Jun-81	Unknown	863,000	816	831
	3		CC	NG	FO2	PL	PL	Unknown	Feb-94	Unknown	612,000	474	500
	4		CC	NG	FO2	PL	PL	Unknown	Apr-94	Unknown	612,000	474	500
St Lucie		St Lucie County 16/36S/41E									<u>1,553,000</u>	<u>1,553</u>	<u>1,579</u>
	1		NP	UR	No	TK	No	Unknown	May-76	Unknown	839,000	839	853
	2	2/	NP	UR	No	TK	No	Unknown	Jun-83	Unknown	714,000	714	726
Cape Canaveral		Brevard County 19/24S/36F									<u>804,100</u>	<u>806</u>	<u>812</u>
	1		ST	FO6	NG	WA	PL	Unknown	Apr-65	Unknown	402,050	403	406
	2		ST	FO6	NG	WA	PL	Unknown	May-69	Unknown	402,050	403	406
Sanford		Volusia County 16/19S/30E									<u>1,022,450</u>	<u>914</u>	<u>919</u>
	3		ST	FO6	NG	WA	PL	Unknown	May-59	Unknown	150,250	142	144
	4		ST	FO6	NG	WA	PL	Unknown	Jul-72	Unknown	436,100	381	384
	5		ST	FO6	No	WA	No	Unknown	Jul-73	Unknown	436,100	391	391

1/ These ratings are peak capability

2/ Total capability is 839/853 MW Capabilities shown represent the company's share of the unit and exclude the Orlando Utilities Commission (OUC) and Florida Municipal Power Agency (FMFA) combined portion of 14.89551%.

Schedule 1

**Existing Generating Facilities
As of December 31, 2000**

(1)	(2)	(3)	(4)	(5)	(6)	(7)	(8)	(9)	(10)	(11)	(12)	(13)	(14)
<u>Plant Name</u>	<u>Unit No</u>	<u>Location</u>	<u>Unit Type</u>	<u>Fuel</u>		<u>Transport</u>		<u>Fuel Days Use</u>	<u>Commercial In-Service Month/Year</u>	<u>Expected Retirement Month/Year</u>	<u>Gen Max Nameplate KW</u>	<u>Net Capability 1/</u>	
				<u>Pri</u>	<u>Alt</u>	<u>Pri</u>	<u>Alt</u>					<u>Summer MW</u>	<u>Winter MW</u>
Putnam		Putnam County 16/10S/27E									580,000	498	594
	1		CC	NG	FO2	PL	WA	Unknown	Apr-78	Unknown	290,000	249	297
	2		CC	NG	FO2	PL	WA	Unknown	Aug-77	Unknown	290,000	249	297
Fort Myers		Lee County 35/43S/25E									1,302,250	1,626	1,856
	1		ST	FO6	No	WA	No	Unknown	Nov-58	Unknown	156,250	141	142
	2		ST	FO6	No	WA	No	Unknown	Jul-69	Unknown	402,000	402	402
	1-12		GT	FO2	No	WA	No	Unknown	May-74	Unknown	744,000	636	769
	Repowering CT's (3)		GT	NG	FO2	PL	PL	Unknown	Dec-00	Unknown	543,000	447	543
Manatee		Manatee County 18/33S/20E									1,726,600	1,625	1,639
	1		ST	FO6	No	WA	No	Unknown	Oct-76	Unknown	863,300	815	822
	2		ST	FO6	No	WA	No	Unknown	Dec-77	Unknown	863,300	810	817
St Johns River Power Park 2/		Duval County 12/15/28E									250,000	254	260
	1		BIT	BIT	No	RR	No	Unknown	Mar-87	Unknown	125,000	127	130
	2		BIT	BIT	No	RR	No	Unknown	May-88	Unknown	125,000	127	130
Scherer 3/		Monroe, GA									891,000	658	666
	4		BIT	BIT	No	RR	No	Unknown	Jul-89	Unknown	891,000	658	666
Total System as of December 31, 2000 =												16,864	17,750

1/ These ratings are peak capability.

2/ The net capability ratings represent Florida Power & Light Company's share of St. Johns River Park Unit No 1 and No 2, excluding Jacksonville Electric Authority (JEA) share of 80%.; SJRPP receives coal by water (WA) in addition to rail

3/ These ratings represent Florida Power & Light Company's share of Scherer Unit No 4, adjusted for transmission losses

**Schedule 2.1
History and Forecast of Energy Consumption
And Number of Customers by Customer Class**

(1)	(2)	(3)	(4)	(5)	(6)	(7)	(8)	(9)
<u>Rural & Residential</u>						<u>Commercial</u>		
<u>Year</u>	<u>Population**</u>	<u>Members per Household</u>	<u>GWH</u>	<u>Average*** No of Customers</u>	<u>Average KWH Consumption Per Customer</u>	<u>GWH</u>	<u>Average*** No of Customers</u>	<u>Average KWH Consumption Per Customer</u>
1991	6,211,996	2.17	34,617	2,863,198	12,090	27,232	343,834	79,200
1992	6,314,005	2.17	34,198	2,911,807	11,745	26,991	350,269	77,058
1993	6,380,715	2.14	36,360	2,975,479	12,220	28,508	358,679	79,481
1994	6,516,879	2.15	38,716	3,037,629	12,745	29,946	366,409	81,729
1995	6,639,165	2.14	40,556	3,097,192	13,094	30,719	374,005	82,135
1996	6,754,084	2.14	41,302	3,152,625	13,101	31,211	380,860	81,949
1997	6,884,909	2.15	41,849	3,209,298	13,040	32,942	388,906	84,703
1998	7,014,152	2.15	45,482	3,266,011	13,926	34,618	396,749	87,255
1999	7,133,361	2.14	44,187	3,332,422	13,260	35,524	404,942	87,725
2000	7,282,933	2.13	46,320	3,414,002	13,568	37,001	415,295	89,096
2001 *	7,406,700	2.13	46,949	3,471,810	13,523	39,840	426,053	93,508
2002 *	7,527,519	2.13	48,497	3,538,346	13,706	41,421	437,810	94,608
2003 *	7,645,392	2.12	49,807	3,603,435	13,822	43,654	448,835	97,262
2004 *	7,760,318	2.12	50,558	3,666,716	13,788	44,537	459,199	96,989
2005 *	7,872,296	2.11	51,302	3,727,940	13,762	45,404	469,038	96,803
2006 *	7,983,660	2.11	52,026	3,786,871	13,738	46,220	478,234	96,647
2007 *	8,095,024	2.11	52,730	3,843,274	13,720	47,004	487,101	96,498
2008 *	8,208,083	2.11	53,425	3,897,570	13,707	47,799	495,697	96,427
2009 *	8,322,839	2.11	54,141	3,950,803	13,704	48,619	504,107	96,446
2010 *	8,437,594	2.11	54,952	4,003,154	13,727	49,516	512,269	96,660

* Forecasted values for these years reflect the Most Likely economic scenario

** Population represents only the area served by FPL.

*** Average No of Customers is the annual average of the twelve month values

Schedule 2.2
History and Forecast of Energy Consumption
And Number of Customers by Customer Class

(1)	(10)	(11)	(12)	(13)	(14)	(15)	(16)
Year	GWH	Industrial	Average KWH	Railroads	Street &	Other	Total***
		Average** No of Customers	Consumption Per Customer	& Railways GWH	Highway Lighting GWH	Sales to Public Authorities GWH	Sales to Ultimate Consumers GWH
1991	4,090	15,348	266,493	81	345	733	67,098
1992	4,054	14,788	274,135	77	353	721	66,393
1993	3,889	14,866	261,602	79	330	665	69,830
1994	3,845	15,588	246,658	85	353	664	73,608
1995	3,883	15,140	256,481	84	358	648	76,248
1996	3,792	14,783	256,515	83	368	577	77,334
1997	3,894	14,761	263,830	85	383	702	79,855
1998	3,951	15,126	261,233	81	373	625	85,131
1999	3,948	16,040	246,112	79	473	465	84,676
2000	3,768	16,410	229,592	81	408	381	87,959
2001	* 3,953	15,631	252,888	80	406	500	91,728
2002	* 3,987	15,637	255,005	81	404	523	94,913
2003	* 4,016	15,665	256,344	82	404	540	98,503
2004	* 4,047	15,743	257,072	83	405	553	100,183
2005	* 4,084	15,836	257,914	84	408	563	101,845
2006	* 4,111	15,901	258,540	83	411	571	103,421
2007	* 4,135	15,966	258,995	83	414	577	104,944
2008	* 4,158	16,029	259,397	84	419	582	106,466
2009	* 4,175	16,075	259,699	84	423	586	108,026
2010	* 4,199	16,280	257,919	83	428	589	109,767

* Forecasted values for these years reflect the Most Likely economic scenario
** Average No of Customers is the annual average of the twelve month values
*** Total Sales GWH = Col 4 + Col 7 + Col 10 + Col. 13 + Col 14 + Col 15

**Schedule 2.3
History and Forecast of Energy Consumption
And Number of Customers by Customer Class**

(1)	(17)	(18)	(19)	(20)	(21)
<u>Year</u>	Sales for Resale <u>GWH</u>	Utility Use & Losses <u>GWH</u>	Net*** Energy For Load <u>GWH</u>	Average ** No of Other <u>Customers</u>	Total Average**** Number of <u>Customers</u>
1991	716	5,346	73,160	4,076	3,226,455
1992	702	6,002	73,097	4,374	3,281,238
1993	958	4,988	75,776	3,086	3,352,110
1994	1,400	5,367	80,376	2,560	3,422,187
1995	1,437	6,276	83,961	2,460	3,488,796
1996	1,353	5,984	84,671	2,480	3,550,748
1997	1,228	5,770	86,853	2,520	3,615,465
1998	1,326	6,205	92,662	2,584	3,680,470
1999	953	5,829	91,458	2,605	3,756,009
2000	970	7,059	95,989	2,694	3,848,401
2001	* 992	6,837	99,557	2,604	3,916,098
2002	* 1,215	7,087	103,215	2,601	3,994,394
2003	* 1,434	7,369	107,306	2,598	4,070,533
2004	* 1,455	7,493	109,131	2,595	4,144,253
2005	* 1,474	7,617	110,936	2,592	4,215,407
2006	* 1,474	7,733	112,628	2,589	4,283,595
2007	* 1,407	7,913	114,264	2,586	4,348,927
2008	* 1,073	8,360	115,899	2,583	4,411,879
2009	* 1,073	8,476	117,577	2,580	4,473,566
2010	* 1,073	8,607	119,447	2,577	4,534,280

* Forecasted values for these years reflect the Most Likely economic scenano.
 ** Average Number of Customers is the annual average of the twelve month values
 *** Net Energy for Load GWH = Col. 16 + Col 17 + Col. 18
 **** Average No of Customers Total = Col 5 + Col 8 + Col 11 + Col. 20

**Schedule 3.1
History and Forecast of Summer Peak Demand: Base Case**

(1)	(2)	(3)	(4)	(5)	(6)	(7)	(8)	(9)	(10)
Year	Total	Wholesale	Retail	Interruptible	Res Load Management	Residential Conservation	C/I Load Management	C/I Conservation	Net Firm Demand
1991	14,123	281	13,842	0	160	129	177	38	13,786
1992	14,661	223	14,438	0	234	151	248	51	14,179
1993	15,266	397	14,869	0	311	182	320	79	14,635
1994	15,179	409	14,770	0	392	220	354	125	14,433
1995	16,172	435	15,737	0	466	259	391	193	15,315
1996	16,064	364	15,700	0	531	339	414	296	15,119
1997	16,613	380	16,233	0	615	440	432	341	15,566
1998	17,897	426	17,471	0	656	480	441	359	16,800
1999	17,615	169	17,446	0	722	565	450	397	16,443
2000	17,808	161	17,647	0	767	626	456	432	16,585
2001	18,150	148	18,003	0	784	87	480	55	16,744
2002	18,801	225	18,576	0	793	128	490	74	17,316
2003	19,507	227	19,280	0	799	169	499	93	17,947
2004	19,964	229	19,735	0	805	211	510	113	18,325
2005	20,433	231	20,201	0	811	254	519	134	18,715
2006	20,918	231	20,687	0	817	298	527	154	19,122
2007	21,392	231	21,160	0	822	343	535	174	19,518
2008	21,788	156	21,632	0	827	389	543	193	19,836
2009	22,220	156	22,063	0	831	436	549	212	20,192
2010	22,722	156	22,565	0	832	451	550	219	20,670

Historical Values (1991 - 2000):

Cols. (2) - (4) are actual values for historical summer peaks. As such, they incorporate the effects of conservation (Cols (7&9)), and MAY incorporate the effects of load control IF load control was operated on these peak days. Therefore, Col. (2) represents the actual Net Firm Demand. Cols (5) - (9) represent actual DSM capabilities starting from January 1988.

Note that the values for FPL's former Interruptible Rate are incorporated into Col (8), which also includes CILC and GS-LC.

Col (10) represents a HYPOTHETICAL "Net Firm Demand" if the load control values had definitely been exercised on the peak. Col (10) is derived by the formula: Col. (10) = Col (2) - Col.(6) - Col (8)

Projected Values (2001 - 2010):

Cols. (2) - (4) represent FPL's forecasted peak w/o incremental conservation or cumulative load control. The effects of conservation implemented prior to 2000 are incorporated into the forecast.

Cols. (5) - (9) represent all incremental conservation and cumulative load control. These values are projected August values and are based on projections with a 1/2000 starting point.

Col (10) represents a "Net Firm Demand" which accounts for all of the incremental conservation and assumes all of the load control is implemented on the peak. Col (10) is derived by using the formula: Col (10) = Col (2) - Col (5) - Col (6) - Col (7) - Col (8) - Col (9)

**Schedule 3.2
History and Forecast of Winter Peak Demand:Base Case**

(1)	(2)	(3)	(4)	(5)	(6)	(7)	(8)	(9)	(10)
Year	Total	Firm Wholesale	Retail	Interruptible	Res Load Management	Residential Conservation	C/I Load Management	C/I Conservation	Net Firm Demand
1991/92	13,319	105	13,214	0	174	170	193	38	12,952
1992/93	12,964	102	12,862	0	242	195	275	48	12,447
1993/94	12,594	278	12,316	0	317	231	342	67	11,935
1994/95	16,563	635	15,928	0	393	265	360	93	15,810
1995/96	18,096	698	17,398	0	459	310	406	143	17,231
1996/97	16,490	626	15,864	0	731	368	418	154	15,341
1997/98	13,060	239	12,821	0	823	403	429	168	11,807
1998/99	16,802	149	16,653	0	1,218	438	417	182	15,167
1999/00	17,057	142	16,915	0	1,296	469	441	193	15,320
2000/01	18,219	150	18,069	0	972	493	448	201	16,799
2001/02	19,333	130	19,203	0	1,403	81	459	26	17,364
2002/03	20,122	206	19,915	0	1,414	107	465	33	18,103
2003/04	20,555	208	20,347	0	1,425	132	471	41	18,486
2004/05	20,986	210	20,776	0	1,436	156	477	50	18,867
2005/06	21,413	210	21,203	0	1,446	181	483	59	19,244
2006/07	21,841	210	21,631	0	1,455	205	487	68	19,626
2007/08	22,186	135	22,051	0	1,464	228	492	77	19,925
2008/09	22,586	135	22,451	0	1,473	251	497	86	20,279
2009/10	22,978	135	22,843	0	1,480	272	500	93	20,633

Historical Values (1991/92 - 2000/01):

Cols (2) - (4) are actual values for historical winter peaks. As such, they incorporate the effects of conservation (Cols. (7&9)), and MAY incorporate the effects of load control IF load control was operated on these peak days. Therefore, Col (2) represents the actual Net Firm Demand. Cols (5) - (9) represent actual DSM capabilities starting from January 1988.

Note that the values for FPL's former Interruptible Rate are incorporated into Col (8), which also includes CILC and GS - LC. Col. (10) represents a HYPOTHETICAL "Net Firm Demand" if the load control values had definitely been exercised on the peak. Col. (10) is derived by the formula: Col.(10) = Col (2) - Col (6) - Col (8)

Projected Values (2001/02-2009/10):

Cols. (2) - (4) represent FPL's forecasted peak w/o incremental conservation or cumulative load control. The effects of conservation implemented prior to 1997 are incorporated into the forecast.

Cols. (5) - (9) represent all incremental conservation and cumulative load control. These values in are projected August values and are based on projections with a 1/2000 starting point.

Col. (10) represents a "Net Firm Demand" which accounts for all of the incremental conservation and assumes all of the load control is implemented on the peak. Col (10) is derived by using the formula: Col (10) = Col (2) - Col (5) - Col (6) - Col (7) - Col (8) - Col (9)

Col. (10) represents a "Net Firm Demand" which accounts for all of the incremental conservation and assumes all of the load control is implemented on the peak. Col (10) is derived by using the formula: Col (10) = Col (2) - Col.(5) - Col (6) - Col (7) - Col (8) - Col (9)

Schedule 3.3
History and Forecast of Annual Net Energy for Load - GWH: Base Case

(1)	(2)	(3)	(4)	(5)	(6)	(7)	(8)	(9)
Year	Total	Residential Conservation	C/I Conservation	Retail	Wholesale	Utility Use & Losses	Net Energy For Load	Load Factor(%)
1991	73,743	397	186	73,027	716	5,346	73,160	59.1%
1992	73,778	460	221	73,076	702	6,002	73,097	56.9%
1993	76,632	553	303	75,674	958	4,988	75,776	56.7%
1994	81,493	661	456	80,093	1,400	5,367	80,376	60.4%
1995	85,415	777	677	83,978	1,437	6,276	83,961	59.3%
1996	86,708	971	1,039	85,355	1,353	5,984	84,698	60.2%
1997	89,240	1,213	1,174	88,012	1,228	5,770	86,853	59.7%
1998	95,316	1,374	1,279	93,990	1,326	6,205	92,663	63.0%
1999	94,361	1,542	1,362	93,408	953	5,829	91,458	63.5%
2000	99,094	1,674	1,431	98,123	970	7,059	95,989	66.1%
2001	99,557	56	15	98,565	992	6,837	99,486	67.8%
2002	103,215	152	46	102,000	1,215	7,087	103,017	67.9%
2003	107,306	250	77	105,872	1,434	7,369	106,979	68.0%
2004	109,131	349	110	107,676	1,455	7,493	108,672	67.7%
2005	110,936	450	145	109,462	1,474	7,617	110,341	67.3%
2006	112,628	554	180	111,155	1,474	7,733	111,894	66.8%
2007	114,264	659	213	112,857	1,407	7,913	113,392	66.3%
2008	115,899	765	245	114,826	1,073	8,360	114,889	66.1%
2009	117,577	874	276	116,504	1,073	8,476	116,427	65.8%
2010	119,447	919	291	118,374	1,073	8,607	118,237	65.3%

Historical Values (1991 - 2000):

Col (2) represents derived "Total Net Energy For Load w/o DSM" The values are calculated using the formula. Col.(2) = Col (8) + Col.(3) + Col.(4).
 Cols. (3) & (4) are DSM values starting in January, 1988 through 1997 which contributed to the values in Cols (5) - (9)
 Cols. (5) & (6) are a breakdown of Net Energy For Load in Col (2) into Retail and Wholesale
 Col (9) is calculated using Col (8) from this page and Col. (2), "Total", from Schedule 3.1

Projected Values (2001 - 2010):

Col (2) represents Net Energy for Load w/o DSM values
 Cols (3) - (4) are forecasted values of the reduction on sales from incremental conservation.
 Cols (5) & (6) are a breakdown of Net Energy For Load in Col (2) , into Wholesale and Retail
 Col. (10) represents a "Net Firm Demand" which accounts for all of the incremental conservation and assumes all of the load control is implemented the values for Col (8) above and the values for Col (10) on Schedule 3.1

Schedule 4
Previous Year Actual and Two-Year Forecast of Retail Peak Demand and Net Energy for Load by Month

(1)	(2)	(3)	(4)	(5)	(6)	(7)
	2000 ACTUAL		2001 * FORECAST		2002 * FORECAST	
Month	Total Peak Demand MW	NEL GWH	Total Peak Demand MW	NEL GWH	Total Peak Demand MW	NEL GWH
JAN	17,057	6,947	18,840	7,427	19,333	7,700
FEB	12,755	6,377	16,776	6,783	17,259	7,033
MAR	13,411	7,099	14,529	7,282	14,948	7,550
APR	14,959	7,424	14,120	7,494	14,626	7,769
MAY	16,856	8,287	15,487	8,036	16,042	8,332
JUN	16,979	9,336	17,099	9,351	17,712	9,695
JUL	17,778	9,216	17,749	9,675	18,386	10,031
AUG	17,808	9,743	18,150	10,168	18,801	10,542
SEP	17,701	9,694	17,625	9,861	18,257	10,223
OCT	16,920	7,712	16,358	8,430	16,944	8,739
NOV	13,804	7,184	15,257	7,646	15,696	7,927
DEC	14,858	6,971	15,593	7,402	16,042	7,674
TOTALS		95,989		99,557		103,215

* Forecasted Peaks & NEL do not include the impacts of cumulative load management and incremental conservation.

Schedule 5
Fuel Requirements 1/

<u>Fuel Requirements</u>	<u>Units</u>	<u>Actual 2/</u>		<u>Forecasted</u>									
		<u>1999</u>	<u>2000</u>	<u>2001</u>	<u>2002</u>	<u>2003</u>	<u>2004</u>	<u>2005</u>	<u>2006</u>	<u>2007</u>	<u>2008</u>	<u>2009</u>	<u>2010</u>
(1) Nuclear	Trillion BTU	268	268	257	263	258	258	263	258	257	263	258	257
(2) Coal	1,000 TON	3,107	4,170	3,788	3,552	3,705	3,556	3,629	4,019	3,795	3,817	4,073	3,821
(3)													
(4) Residual(FO6)- Total	1,000 BBL	36,475	36,859	32,769	26,951	24,455	26,018	19,352	14,059	12,416	12,546	11,973	9,188
(5) Steam	1,000 BBL	36,475	36,859	32,769	26,951	24,455	26,018	19,352	14,059	12,416	12,546	11,973	9,188
(6) Distillate(FO2)- Total	1,000 BBL	488	461	505	315	2,350	2,642	449	381	212	316	181	46
(7) CC	1,000 BBL	3	14	0	0	0	0	0	0	0	0	0	0
(8) CT	1,000 BBL	405	1	0	74	1,959	2,118	406	356	195	289	160	33
(9) Steam	1,000 BBL	80	446	505	241	391	524	42	25	17	27	21	13
(10) Natural Gas -Total	1,000 MCF	193,723	203,234	248,439	299,368	319,720	321,203	378,635	423,640	446,604	452,639	468,918	519,426
(11) Steam	1,000 MCF	73,309	80,967	100,772	76,589	9,521	9,519	7,046	5,361	4,919	4,795	4,736	3,888
(12) CC	1,000 MCF	3,535	117,684	139,066	214,673	308,615	310,455	371,466	418,226	441,651	447,780	464,137	515,507
(13) CT	1,000 MCF	116,879	4,583	8,601	8,106	1,584	1,229	124	54	34	63	45	32

1/ Reflects fuel requirements for FPL only

2/ Source A Schedules

**Schedule 6.1
Energy Sources**

Energy Sources	Units	Actual 1/		Forecasted									
		1999	2000	2001	2002	2003	2004	2005	2006	2007	2008	2009	2010
(1) Annual Energy Interchange 2/	GWH	8,180	10,092	12,386	11,509	9,611	10,029	9,169	8,492	8,452	8,332	8,282	5,582
(2) Nuclear	GWH	24,706	24,584	23,776	24,284	23,873	23,844	24,284	23,874	23,778	24,331	23,874	23,778
(3) Coal	GWH	6,146	6,977	6,906	6,504	6,711	6,541	6,660	7,307	6,942	6,980	7,398	6,986
(4) Residual(FO6) -Total	GWH	22,903	23,230	20,706	16,871	15,375	16,370	12,211	8,869	7,833	7,911	7,556	5,828
(5) Steam	GWH	22,903	23,230	20,706	16,871	15,375	16,370	12,211	8,869	7,833	7,911	7,556	5,828
(6) Distillate(FO2) -Total	GWH	167	193	213	159	1,674	1,865	331	282	156	232	131	31
(7) CC	GWH	2	9	0	0	0	0	0	0	0	0	0	0
(8) CT	GWH	165	1	0	58	1,461	1,581	312	271	149	220	123	26
(9) Steam	GWH	0	183	213	101	212	284	19	11	7	11	9	5
(10) Natural Gas -Total	GWH	23,098	24,217	28,259	37,053	43,976	44,209	52,388	58,883	62,148	63,034	65,297	72,491
(11) Steam	GWH	7,038	7,840	9,398	7,226	851	849	626	474	435	423	418	346
(12) CC	GWH	15,863	16,064	18,120	29,105	42,983	43,251	51,753	58,406	61,711	62,608	64,876	72,143
(13) CT	GWH	197	313	741	723	143	110	9	3	2	4	3	2
(14) Other 3/	GWH	6,349	6,696	7,240	6,636	5,759	5,814	5,298	4,187	4,082	4,069	3,888	3,540
Net Energy For Load 4/	GWH	91,549	95,989	99,486	103,017	106,979	108,672	110,341	111,894	113,392	114,889	116,427	118,237

1/ Source A Schedules

2/ The projected figures are based on estimated energy purchases from SJRPP and the Southern Companies

3/ Represents a forecast of energy expected to be purchased from Qualifying Facilities, Independent Power Producers, etc

4/ Net Energy For Load is Column 2 on Schedule 3.3 and Column 1 on EIA411 Form 11C

Schedule 6.2
Energy % by Fuel Type

Energy Source	Units	Actual 1/		Forecasted									
		1999	2000	2001	2002	2003	2004	2005	2006	2007	2008	2009	2010
(1) Annual Energy Interchange 2/	%	8.9	10.5	12.4	11.2	9.0	9.2	8.3	7.6	7.5	7.3	7.1	4.7
(2) Nuclear	%	27.0	25.6	23.9	23.6	22.3	21.9	22.0	21.3	21.0	21.2	20.5	20.1
(3) Coal	%	6.7	7.3	6.9	6.3	6.3	6.0	6.0	6.5	6.1	6.1	6.4	5.9
(4) Residual(FO6) -Total	%	25.0	24.2	20.8	16.4	14.4	15.1	11.1	7.9	6.9	6.9	6.5	4.9
(5) Steam	%	25.0	24.2	20.8	16.4	14.4	15.1	11.1	7.9	6.9	6.9	6.5	4.9
(6) Distillate(FO2) -Total	%	0.2	0.2	0.2	0.2	1.6	1.7	0.3	0.3	0.1	0.2	0.1	0.0
(7) CC	%	0.0	0.0	0.0	0.0	0.0	0.0	0.0	0.0	0.0	0.0	0.0	0.0
(8) CT	%	0.2	0.0	0.0	0.1	1.4	1.5	0.3	0.2	0.1	0.2	0.1	0.0
(9) Steam	%	0.0	0.2	0.2	0.1	0.2	0.3	0.0	0.0	0.0	0.0	0.0	0.0
(10) Natural Gas -Total	%	25.2	25.2	28.4	36.0	41.1	40.7	47.5	52.6	54.8	54.9	56.1	61.3
(11) Steam	%	7.7	8.2	9.4	7.0	0.8	0.8	0.6	0.4	0.4	0.4	0.4	0.3
(12) CC	%	17.3	16.7	18.2	28.3	40.2	39.8	46.9	52.2	54.4	54.5	55.7	61.0
(13) CT	%	0.2	0.3	0.7	0.7	0.1	0.1	0.0	0.0	0.0	0.0	0.0	0.0
(14) Other 3/	%	6.9	7.0	7.3	6.4	5.4	5.4	4.8	3.7	3.6	3.5	3.3	3.0
		100	100	100	100	100	100	100	100	100	100	100	100

1/ Source A Schedules

2/ The projected figures are based on estimated energy purchases from SJRPP and the Southern Companies

3/ Represents a forecast of energy expected to be purchased from Qualifying Facilities, Independent Power Producers, etc

**Schedule 7.1
Forecast of Capacity, Demand, and Scheduled
Maintenance At Time Of Summer Peak**

(1)	(2)	(3)	(4)	(5)	(6)	(7)	(8)	(9)	(10)	(11)	(12)	(13)	(14)
Year	Total Installed 1/ Capacity MW	Firm Capacity Import 2/ MW	Firm Capacity Export MW	Firm QF MW	Total Capacity Available 3/ MW	Total Peak 4/ Demand MW	DSM 5/ MW	Firm Summer Peak Demand MW	Reserve Margin Before Maintenance 6/ MW	% of Peak	Scheduled Maintenance MW	Reserve Margin After Maintenance 7/ MW	% of Peak
2001	17,704	1,509	0	886	20,099	18,150	1,406	16,744	3,355	20.0	0	3,355	20.0
2002	17,915	2,288	0	877	21,080	18,801	1,485	17,316	3,764	21.7	0	3,764	21.7
2003	19,170	2,288	0	877	22,335	19,507	1,560	17,947	4,388	24.4	0	4,388	24.4
2004	19,170	2,288	0	877	22,335	19,964	1,639	18,325	4,010	21.9	0	4,010	21.9
2005	20,762	1,313	0	867	22,942	20,433	1,718	18,715	4,227	22.6	0	4,227	22.6
2006	21,309	1,313	0	734	23,356	20,918	1,796	19,122	4,234	22.1	0	4,234	22.1
2007	21,856	1,313	0	734	23,903	21,392	1,874	19,518	4,385	22.5	0	4,385	22.5
2008	21,856	1,313	0	734	23,903	21,788	1,952	19,836	4,067	20.5	0	4,067	20.5
2009	22,403	1,313	0	683	24,399	22,220	2,028	20,192	4,207	20.8	0	4,207	20.8
2010	24,044	382	0	640	25,066	22,722	2,052	20,670	4,396	21.3	0	4,396	21.3

1/ Capacity additions and changes projected to be in-service by June 1st are considered to be available to meet Summer peak loads which are forecasted to occur during August of the year indicated. All values are Summer net MW.

2/ Firm Capacity Imports include all firm capacity purchases whether from out-of-state or in-state.

3/ Total Capacity Available = Col (2) + Col (3) - Col (4) + Col (5)

4/ These forecasted values reflect the Most Likely forecast without DSM.

5/ The MW shown represent cumulative load management capability plus incremental conservation from 1/99 - on. They are not included in total additional resources but reduce the peak load upon which Reserve Margin calculations are based.

6/ Margin (%) Before Maintenance = Col (10)/Col (9)

7/ Margin (%) After Maintenance = Col (13)/Col (9)

Schedule 7.2
Forecast of Capacity , Demand, and Scheduled
Maintenance At Time of Winter Peak

(1)	(2)	(3)	(4)	(5)	(6)	(7)	(8)	(9)	(10)	(11)	(12)	(13)	(14)
Year	Total Installed 1/ Capability MW	Firm Capacity Import 2/ MW	Firm Capacity Export MW	Firm QF MW	Total Capacity Available 3/ MW	Total Peak 4/ Demand MW	DSM 5/ MW	Firm Winter Peak Demand MW	Reserve Margin Before Maintenance 6/ MW % of Peak	Scheduled Maintenance MW	Reserve Margin After Maintenance 7/ MW % of Peak		
2000/01	17,785	1,319	0	886	19,990	18,840	1,902	16,938	3,052	18 0	0	3,052	18 0
2001/02	17,752	1,369	0	886	20,007	19,333	1,969	17,364	2,643	15 2	0	2,643	15 2
2002/03	20,019	2,394	0	877	23,290	20,122	2,019	18,103	5,187	28 7	0	5,187	28 7
2003/04	20,381	2,394	0	877	23,652	20,555	2,069	18,486	5,166	27 9	0	5,166	27 9
2004/05	20,381	2,344	0	867	23,592	20,986	2,119	18,867	4,725	25 0	0	4,725	25 0
2005/06	22,041	1,319	0	734	24,094	21,413	2,169	19,244	4,850	25 2	0	4,850	25 2
2006/07	22,637	1,319	0	734	24,690	21,841	2,215	19,626	5,064	25 8	0	5,064	25 8
2007/08	23,233	1,319	0	734	25,286	22,186	2,261	19,925	5,361	26 9	0	5,361	26 9
2008/09	23,233	1,319	0	734	25,286	22,586	2,307	20,279	5,007	24 7	0	5,007	24 7
2009/10	23,829	1,319	0	683	25,831	22,978	2,345	20,633	5,198	25 2	0	5,198	25 2

* Denotes actual installed capability and total peak demand All other assumptions are projections

1/ Capacity additions and changes projected to be in-service by January 1st are considered to be available to meet Winter peak loads which are forecasted to occur during January of the "second" year indicated All values are Winter net MW

2/ Firm Capacity Imports include all firm capacity purchases whether from out - of - state or in - state

3/ Total Capacity Available = Col (2) + Col (3) - Col (4) + Col (5)

4/ These forecasted values reflect the Most Likely forecast without DSM

5/ The MW shown represent cumulative load management capability plus incremental conservation They are not included in total additional resources but reduce the peak load upon which Reserve Margin calculations are based

6/ Margin (%) Before Maintenance = Col (10) /Col (9)

7/ Margin (%) After Maintenance = Col (13) /Col (9)

Schedule 8
Planned And Prospective Generating Facility Additions And Changes

(1)	(2)	(3)	(4)	(5)	(6)	(7)	(8)	(9)	(10)	(11)	(12)	(13)	(14)	(15)
Plant Name	Unit No	Location	Unit Type	Fuel		Fuel Transport		Const Start Mo /Yr	Comm In-Service Mo /Yr	Expected Retirement Mo /Yr	Gen Max Nameplate KW	Net Capability		Status
				Pri	Alt	Pri	Alt					Winter MW	Summer MW	
<u>ADDITIONS</u>														
<u>2001</u>														
Martin Combustion Turbines	8A	Martin County 29/29S/38E	CT	NG	FO2	PL	PL	Apr-99	Jun-01	Unknown	190,000	—	149	P
Martin Combustion Turbines	8B	Martin County 29/29S/38E	CT	NG	FO2	PL	PL	Apr-99	Jun-01	Unknown	190,000	—	149	P
2001 Total:												0	298	
<u>2002</u>														
Martin Combustion Turbines	8A	Martin County 29/29S/38E	CT	NG	FO2	PL	PL	Apr-99	Jun-01	Unknown	190,000	181	—	P
Martin Combustion Turbines	8B	Martin County 29/29S/38E	CT	NG	FO2	PL	PL	Apr-99	Jun-01	Unknown	190,000	181	—	P
2002 Total:												362	---	
<u>2003</u>														
Fort Myers Combustion Turbines	13	Lee County 35/43S/25E	CT	NG	FO2	PL	PL	Apr-02	Apr-03	Unknown	190,000	—	149	P
Fort Myers Combustion Turbines	14	Lee County 35/43S/25E	CT	NG	FO2	PL	PL	Apr-02	May-03	Unknown	190,000	—	149	P
2003 Total:												---	298	
<u>2004</u>														
Fort Myers Combustion Turbines	13	Lee County 35/43S/25E	CT	NG	FO2	PL	PL	Apr-02	Apr-03	Unknown	190,000	181	—	P
Fort Myers Combustion Turbines	14	Lee County 35/43S/25E	CT	NG	FO2	PL	PL	Apr-02	May-03	Unknown	190,000	181	—	P
2004 Total:												362	---	
<u>2005</u>														
Martin Combined Cycle Unit	5	Martin County 29/29S/38E	CC	NG	FO2	PL	PL	Jun-02	Jun-05	Unknown	470,000	—	547	P
Midway Combined Cycle Unit	1	St Lucie County 2/36S/39E	CC	NG	FO2	PL	PL	Jun-02	Jun-05	Unknown	470,000	—	547	P
2005 Total:												---	1094	

Schedule 8
Planned And Prospective Generating Facility Additions And Changes

(1)	(2)	(3)	(4)	(5)	(6)	(7)	(8)	(9)	(10)	(11)	(12)	(13)	(14)	(15)
Plant Name	Unit No	Location	Unit Type	Fuel		Fuel Transport		Const Start Mo /Yr	Comm In-Service Mo /Yr	Expected Retirement Mo /Yr	Gen Max Nameplate KW	Net Capability		Status
				Pri	Alt	Pri	Alt					Winter MW	Summer MW	
<u>ADDITIONS</u>														
<u>2006</u>														
Martin Combined Cycle Unit	5	Martin County 29/29S/38E	CC	NG	FO2	PL	PL	Jun-02	Jun-05	Unknown	470,000	596	---	P
Midway Combined Cycle Unit	1	St Lucie County 2/36S/39E	CC	NG	FO2	PL	PL	Jun-02	Jun-05	Unknown	470,000	596	---	P
Martin Combined Cycle Unit	6	Martin County 29/29S/38E	CC	NG	FO2	PL	PL	Jun-03	Jun-06	Unknown	470,000	---	547	P
2006 Total:												1192	547	
<u>2007</u>														
Martin Combined Cycle Unit	6	Martin County 29/29S/38E	CC	NG	FO2	PL	PL	Jun-03	Jun-06	Unknown	470,000	596	---	P
Unsitd Combined Cycle Unit #1	1	Unknown	CC	NG	FO2	PL	PL	Jun-04	Jun-07	Unknown	470,000	---	547	P
2007 Total:												596	547	
<u>2008</u>														
Unsitd Combined Cycle Unit #1	1	Unknown	CC	NG	FO2	PL	PL	Jun-04	Jun-07	Unknown	470,000	596	---	P
2008 Total:												596	0	
<u>2009</u>														
Unsitd Combined Cycle Unit #2	2	Unknown	CC	NG	FO2	PL	PL	Jun-06	Jun-09	Unknown	470,000	---	547	P
2009 Total:												0	547	
<u>2010</u>														
Unsitd Combined Cycle Unit #2	2	Unknown	CC	NG	FO2	PL	PL	Jun-06	Jun-09	Unknown	470,000	596	---	P
Unsitd Combined Cycle Unit #3	3	Unknown	CC	NG	FO2	PL	PL	Jun-07	Jun-10	Unknown	470,000	---	547	P
Unsitd Combined Cycle Unit #4	4	Unknown	CC	NG	FO2	PL	PL	Jun-07	Jun-10	Unknown	470,000	---	547	P
Unsitd Combined Cycle Unit #5	5	Unknown	CC	NG	FO2	PL	PL	Jun-07	Jun-10	Unknown	470,000	---	547	P
2010 Total:												596	1641	

**Schedule 8
Planned And Prospective Generating Facility Additions And Changes (Cont.)**

(1) Plant Name	(2) Unit No	(3) Location	(4) Unit Type	(5) Fuel		(6) Fuel Transport		(7) Const Start Mo /Yr	(8) Comm In-Service Mo /Yr	(9) Expected Retirement Mo /Yr	(10) Gen Max Nameplate KW	(11) Net Capability		(14) Status	
				Pri	Alt	Pri	Alt					Winter ^{1,2)} MW	Summer ^{1,2)} MW		
<u>CHANGES/UPGRADES</u>															
<u>2001</u>															
Martin	1	Martin County	29/29S/38E	ST	NG	FO6	PL	PL	N/A	May-01	Unknown	863,000	0	(30)	OT
Martin	2	Martin County	29/29S/38E	ST	NG	FO6	PL	PL	N/A	May-01	Unknown	863,000	0	(20)	OT
Martin	3	Martin County	29/29S/38E	CC	NG	FO2	PL	PL	N/A	May-01	Unknown	612,000	0	(7)	OT
Martin	4	Martin County	29/29S/38E	CC	NG	FO2	PL	PL	N/A	May-01	Unknown	612,000	0	(7)	OT
Cape Canaveral	2	Brevard County	19/24S/36F	ST	FO6	NG	WA	PL	Nov-00	Nov-00	Unknown	402,050	8	8	OT
Ft Myers Repowering Initial Phase	1 & 2	Lee County	35/43S/25E	CC	NG	No	PL	No	Nov-00	Jan-01	Unknown	161,700	543	894	RP,U
												2001 Total:	551	838	
<u>2002</u>															
Sanford Repowering Initial Phase	4	Volusia County	16/19S/30E	ST	FO6	NG	WA	PL	Jan-00	N/A	Unknown	106,600	0	(390) ³⁾	RP
Sanford Repowering Initial Phase	5	Volusia County	16/19S/30E	ST	FO6	NG	WA	PL	Jan-00	N/A	Unknown	106,600	(394) ³⁾	0	RP
Sanford Repowering Second Phase	5	Volusia County	16/19S/30E	CC	NG	No	PL	No	N/A	Jul-02	Unknown	106,600	0	567	RP
Fort Myers Repowering Second Phase	1 & 2	Lee County	35/43S/25E	CC	NG	No	PL	No	Sep-01	Jan-02	Unknown	161,700	(1)	35	RP,U
												2002 Total:	(395)	212	
<u>2003</u>															
Sanford Repowering Second Phase	4	Volusia County	16/19S/30E	CC	NG	No	PL	No	N/A	Dec-02	Unknown	106,600	671	957	RP
Sanford Repowering Second Phase	5	Volusia County	16/19S/30E	CC	NG	No	PL	No	N/A	Jul-02	Unknown	106,600	1,065	0	RP
Fort Myers Repowering Second Phase	1 & 2	Lee County	35/43S/25E	CC	NG	No	PL	No	Sep-01	Jun-02	Unknown	161,700	531	0	RP,U
												2003 Total:	2,267	957	
<u>2004</u>															
												2004 Total:	0	0	
<u>2005</u>															
Martin Combustion Turbine Conversion	8A	Martin County	29/29S/38E	CT	NG	FO2	PL	PL	Jan-04	Jun-05	Unknown	190,000	---	124.5	P
Martin Combustion Turbine Conversion	8B	Martin County	29/29S/38E	CT	NG	FO2	PL	PL	Jan-04	Jun-05	Unknown	190,000	---	124.5	P
Fort Myers Combustion Turbine Conversion	13	Lee County	35/43S/25E	CT	NG	FO2	PL	PL	Jan-04	Jun-05	Unknown	190,000	---	124.5	P
Fort Myers Combustion Turbine Conversion	14	Lee County	35/43S/25E	CT	NG	FO2	PL	PL	Jan-04	Jun-05	Unknown	190,000	---	124.5	P
												2005 Total:	0	498	

1)The Winter Total MW value consists of all generation additions and changes achieved by January. The Summer Total MW value consists of all generation additions and changes achieved by July. All other MW will be picked up in the following year. This is done for reserve margin calculation.
 2) All MW differences are calculated based on using IRP 2000 Submittal (for the year 2000) as the base for all other years.
 3) Negative values for Sanford and Ft. Myers reflect the existing steam units being temporarily out of service during that seasonal period for repowering efforts.

**Schedule 8
Planned And Prospective Generating Facility Additions And Changes (Cont.)**

(1)	(2)	(3)	(4)	(5)	(6)	(7)	(8)	(9)	(10)	(11)	(12)	(13)	(14)	(15)	
Plant Name	Unit No	Location	Unit Type	Fuel		Fuel Transport		Const Start Mo /Yr	Comm In-Service Mo /Yr	Expected Retirement Mo /Yr	Gen Max Nameplate KW	Net Capability		Status	
				Pri	Alt	Pri	Alt					Winter ¹⁾ MW	Summer ¹⁾ MW		
<u>CHANGES/UPGRADES</u>															
<u>2006</u>															
Martin Combustion Turbine Conversion	8A	Martin County 29/29S/38E	CT	NG	FO2	PL	PL	Jan-04	Jun-05	Unknown	190,000	117 0	--	P	
Martin Combustion Turbine Conversion	8B	Martin County 29/29S/38E	CT	NG	FO2	PL	PL	Jan-04	Jun-05	Unknown	190,000	117 0	--	P	
Fort Myers Combustion Turbine Conversion	13	Lee County 35/43S/25E	CT	NG	FO2	PL	PL	Jan-04	Jun-05	Unknown	190,000	117 0	--	P	
Fort Myers Combustion Turbine Conversion	14	Lee County 35/43S/25E	CT	NG	FO2	PL	PL	Jan-04	Jun-05	Unknown	190,000	117 0	--	P	
												2006 Total:	468	0	
<u>2007</u>															
												2007 Total:	0	0	
<u>2008</u>															
												2008 Total:	0	0	
<u>2009</u>															
												2009 Total:	0	0	
<u>2010</u>															
												2010 Total:	0	0	

1)The Winter Total MW value consists of all generation additions and changes achieved by January. The Summer Total MW value consists of all generation additions and changes achieved by July. All other MW will be picked up in the following year. This is done for reserve margin calculation.

Schedule 9
Status Report and Specifications of Proposed Generating Facilities

- (1) **Plant Name and Unit Number:** Martin Combustion Turbines No. 8A and No. 8B *
- (2) **Capacity**
a. Summer 149 MW
b. Winter 181 MW
- (3) **Technology Type:** Combustion Turbine
- (4) **Anticipated Construction Timing**
a. Field construction start-date: 1999
b. Commercial In-service date: 2001
- (5) **Fuel**
a. Primary Fuel Natural Gas
b. Alternate Fuel Distillate
- (6) **Air Pollution and Control Strategy:** Dry Low Nox Combustors, Natural Gas, 0.05% S. Distillate, & Water Injection on Distillate
- (7) **Cooling Method:** Air Coolers
- (8) **Total Site Area:** 11,300 Acres
- (9) **Construction Status:** P (Planned)
- (10) **Certification Status:** P (Planned)
- (11) **Status with Federal Agencies:** P (Planned)
- (12) **Projected Unit Performance Data:**
Planned Outage Factor (POF): 1%
Forced Outage Factor (FOF): 1%
Equivalent Availability Factor (EAF): 98%
Resulting Capacity Factor (%): Approx. 10% (First Year)
Average Net Operating Heat Rate (ANHOR): 10,430 Btu/kWh
- (13) **Projected Unit Financial Data **,*****
Book Life (Years): 25 years
Total Installed Cost (In-Service Year \$/kW): 477.98
Direct Construction Cost (\$/kW): 449.20
AFUDC Amount (\$/kW): 29.30
Escalation (\$/kW): -0.53
Fixed O&M (\$/kW -Yr.): 0.68
Variable O&M (\$/MWH): 0.86
K Factor: 1.5134

* Values shown are per unit values for the two units being added.

** \$/KW values are based on Summer capacity.

*** Fixed O&M includes capital replacement.

Schedule 9
Status Report and Specifications of Proposed Generating Facilities

- (1) **Plant Name and Unit Number:** Fort Myers Repowering
- (2) **Capacity**
a. Summer 929 MW Incremental (1473 MW Total After Repowering)
b. Winter 1,073 MW Incremental (1617 MW Total After Repowering)
- (3) **Technology Type:** Combined Cycle
- (4) **Anticipated Construction Timing**
a. Field construction start-date: 2000
b. Commercial In-service date: 2002
- (5) **Fuel**
a. Primary Fuel Natural Gas
b. Alternate Fuel None
- (6) **Air Pollution and Control Strategy:** Dry Low Nox Combustors, Natural Gas
- (7) **Cooling Method:** Once-through Cooling
- (8) **Total Site Area:** 460 Acres
- (9) **Construction Status:** P (Planned)
- (10) **Certification Status:** P (Planned)
- (11) **Status with Federal Agencies:** P (Planned)
- (12) **Projected Unit Performance Data:**
Planned Outage Factor (POF): 3%
Forced Outage Factor (FOF): 1%
Equivalent Availability Factor (EAF): 96%
Resulting Capacity Factor (%): 96% (First Year)
Average Net Operating Heat Rate (ANHOR): 6,830 Btu/kWh
- (13) **Projected Unit Financial Data, *,**,*****
Book Life (Years): 25 years
Total Installed Cost (In-Service Year \$/kW): 655.96
Direct Construction Cost (\$/kW): 560.71
AFUDC Amount (\$/kW): 94.59
Escalation (\$/kW): 0.66
Fixed O&M (\$/kW -Yr.): 13.30
Variable O&M (\$/MWH): 0.37
K Factor: 1.5419

* \$/kW values are based on incremental Summer capacity.

** Note that cost values shown do not reflect the FPL system benefits which result from efficiency improvements to the existing steam capacity at the site.

*** Fixed O&M includes capital replacement.

Schedule 9
Status Report and Specifications of Proposed Generating Facilities

- (1) **Plant Name and Unit Number:** Sanford Unit 4 Repowering
- (2) **Capacity**
a. Summer 567 MW Incremental (957 MW Total After Repowering)
b. Winter 671 MW Incremental (1065 MW Total After Repowering)
- (3) **Technology Type:** Combined Cycle
- (4) **Anticipated Construction Timing**
a. Field construction start-date: 2000
b. Commercial In-service date: 2002
- (5) **Fuel**
a. Primary Fuel Natural Gas
b. Alternate Fuel None
- (6) **Air Pollution and Control Strategy:** Dry Low Nox Combustors and Natural Gas
- (7) **Cooling Method:** Cooling Pond
- (8) **Total Site Area:** 1,718 Acres
- (9) **Construction Status:** P (Planned)
- (10) **Certification Status:** P (Planned)
- (11) **Status with Federal Agencies:** P (Planned)
- (12) **Projected Unit Performance Data:**
Planned Outage Factor (POF): 3%
Forced Outage Factor (FOF): 1%
Equivalent Availability Factor (EAF): 96%
Resulting Capacity Factor (%): 96% (First Year)
Average Net Operating Heat Rate (ANHOR): 6,860 Btu/kWh
- (13) **Projected Unit Financial Data *,**,*****
Book Life (Years): 25 years
Total Installed Cost (In-Service Year \$/kW): 708.12
Direct Construction Cost (\$/kW): 595.11
AFUDC Amount (\$/kW): 112.45
Escalation (\$/kW): 0.56
Fixed O&M (\$/kW -Yr.): 14.25
Variable O&M (\$/MWH): 0.37
K Factor: 1.4701

* \$/kW values are based on incremental Summer capacity.

** Note that cost values shown do not reflect the FPL system benefits which result from efficiency improvements to the existing steam capacity at the site.

*** Fixed O&M includes capital replacement.

Schedule 9
Status Report and Specifications of Proposed Generating Facilities

- (1) **Plant Name and Unit Number:** Sanford Unit 5 Repowering
- (2) **Capacity**
a. Summer 567 MW Incremental (957 MW Total After Repowering)
b. Winter 671 MW Incremental (1065 MW Total After Repowering)
- (3) **Technology Type:** Combined Cycle
- (4) **Anticipated Construction Timing**
a. Field construction start-date: 2000
b. Commercial In-service date: 2002
- (5) **Fuel**
a. Primary Fuel Natural Gas
b. Alternate Fuel Distillate
- (6) **Air Pollution and Control Strategy:** Dry Low Nox Combustors, Natural Gas, 0.05% S Distillate, & Water Injection on Distillate
- (7) **Cooling Method:** Cooling Pond
- (8) **Total Site Area:** 1,718 Acres
- (9) **Construction Status:** P (Planned)
- (10) **Certification Status:** P (Planned)
- (11) **Status with Federal Agencies:** P (Planned)
- (12) **Projected Unit Performance Data:**
Planned Outage Factor (POF): 3%
Forced Outage Factor (FOF): 1%
Equivalent Availability Factor (EAF): 96%
Resulting Capacity Factor (%): 96% (First Year)
Average Net Operating Heat Rate (ANHOR): 6,860 Btu/kWh
- (13) **Projected Unit Financial Data *, **, *****
Book Life (Years): 25 years
Total Installed Cost (In-Service Year \$/kW): 678.08
Direct Construction Cost (\$/kW): 595.11
AFUDC Amount (\$/kW): 82.41
Escalation (\$/kW): 0.56
Fixed O&M (\$/kW -Yr.): 14.25
Variable O&M (\$/MWH): 0.37
K Factor: 1.5341

* \$/kW values are based on incremental Summer capacity.

** Note that cost values shown do not reflect the FPL system benefits which result from efficiency improvements to the existing steam capacity at the site.

*** Fixed O&M includes capital replacement.

Schedule 9
Status Report and Specifications of Proposed Generating Facilities

- (1) **Plant Name and Unit Number:** Fort Myers Combustion Turbines No. 13 and No. 14 *
- (2) **Capacity**
a. Summer 149 MW
b. Winter 181 MW
- (3) **Technology Type:** Combustion Turbine
- (4) **Anticipated Construction Timing**
a. Field construction start-date: 2002
b. Commercial In-service date: 2003
- (5) **Fuel**
a. Primary Fuel Natural Gas
b. Alternate Fuel Distillate
- (6) **Air Pollution and Control Strategy:** Dry Low Nox Combustors, Natural Gas, 0.05% S Distillate, & Water Injection on Distillate
- (7) **Cooling Method:** Air Coolers
- (8) **Total Site Area:** 460 Acres
- (9) **Construction Status:** P (Planned)
- (10) **Certification Status:** P (Planned)
- (11) **Status with Federal Agencies:** P (Planned)
- (12) **Projected Unit Performance Data:**
Planned Outage Factor (POF): 1%
Forced Outage Factor (FOF): 1%
Equivalent Availability Factor (EAF): 98%
Resulting Capacity Factor (%): Approx. 10% (First Year)
Average Net Operating Heat Rate (ANHOR): 10,430 Btu/kWh
- (13) **Projected Unit Financial Data **,*****
Book Life (Years): 25 years
Total Installed Cost (In-Service Year \$/kW): 542.80
Direct Construction Cost (\$/kW): 509.94
AFUDC Amount (\$/kW): 31.30
Escalation (\$/kW): 1.56
Fixed O&M (\$/kW -Yr.): 0.68
Variable O&M (\$/MWH): 0.86
K Factor: 1.5247

* Values shown are per unit values for the two units being added.

** \$/KW values are based on Summer capacity.

*** Fixed O&M includes capital replacement.

Schedule 9
Status Report and Specifications of Proposed Generating Facilities

- (1) **Plant Name and Unit Number:** Martin No. 5
- (2) **Capacity**
a Summer 547 MW
b. Winter 596 MW
- (3) **Technology Type:** Combined Cycle
- (4) **Anticipated Construction Timing**
a. Field construction start-date: 2002
b. Commercial In-service date: 2005
- (5) **Fuel**
a. Primary Fuel Natural Gas
b. Alternate Fuel Distillate
- (6) **Air Pollution and Control Strategy:** Dry Low Nox Combustors, Natural Gas, 0.05% S Distillate, & Water Injection on Distillate
- (7) **Cooling Method:** Cooling Pond
- (8) **Total Site Area:** 11,300 Acres
- (9) **Construction Status:** P (Planned)
- (10) **Certification Status:** P (Planned)
- (11) **Status with Federal Agencies:** P (Planned)
- (12) **Projected Unit Performance Data:**
Planned Outage Factor (POF): 3%
Forced Outage Factor (FOF): 1%
Equivalent Availability Factor (EAF): 96%
Resulting Capacity Factor (%): 96% (First Year)
Average Net Operating Heat Rate (ANHOR): 7,150 Btu/kWh
- (13) **Projected Unit Financial Data *,****
Book Life (Years): 25 years
Total Installed Cost (In-Service Year \$/kW): 503.31
Direct Construction Cost (\$/kW): 411.88
AFUDC Amount (\$/kW): 82.95
Escalation (\$/kW): 8.48
Fixed O&M (\$/kW -Yr.): 9.30
Variable O&M (\$/MWH): 0.74
K Factor: 1.5489

* \$/KW values are based on Summer capacity.

** Fixed O&M includes capital replacement.

Schedule 9
Status Report and Specifications of Proposed Generating Facilities

- (1) **Plant Name and Unit Number:** Martin Combustion Turbine Conversion
- (2) **Capacity**
a. Summer 249 MW
b. Winter 234 MW
- (3) **Technology Type:** Combined Cycle
- (4) **Anticipated Construction Timing**
a. Field construction start-date: 2004
b. Commercial In-service date: 2005
- (5) **Fuel**
a. Primary Fuel Natural Gas
b. Alternate Fuel Distillate
- (6) **Air Pollution and Control Strategy:** Dry Low Nox Combustors, Natural Gas, 0.05% S Distillate, & Water Injection on Distillate
- (7) **Cooling Method:** Cooling Pond
- (8) **Total Site Area:** 11,300 Acres
- (9) **Construction Status:** P (Planned)
- (10) **Certification Status:** P (Planned)
- (11) **Status with Federal Agencies:** P (Planned)
- (12) **Projected Unit Performance Data ***
Planned Outage Factor (POF): 3%
Forced Outage Factor (FOF): 1%
Equivalent Availability Factor (EAF): 96%
Resulting Capacity Factor (%): 96% (First Year)
Average Net Operating Heat Rate (ANHOR): 7,150 Btu/kWh
- (13) **Projected Unit Financial Data **,*****
Book Life (Years): 25 years
Total Installed Cost (In-Service Year \$/kW): 481.36
Direct Construction Cost (\$/kW): 433.91
AFUDC Amount (\$/kW): 31.29
Escalation (\$/kW): 16.16
Fixed O&M (\$/kW -Yr.): 9.30 *
Variable O&M (\$/MWH): 0.74 *
K Factor: 1.5147

* Values represent an operational combined cycle unit after the conversion is completed.

** \$/KW values are based on Summer incremental capacity.

*** Fixed O&M cost includes capital replacement.

Schedule 9
Status Report and Specifications of Proposed Generating Facilities

- (1) **Plant Name and Unit Number:** Fort Myers Combustion Turbine Conversion
- (2) **Capacity**
a. Summer 249 MW
b. Winter 234 MW
- (3) **Technology Type:** Combined Cycle
- (4) **Anticipated Construction Timing**
a. Field construction start-date: 2004
b. Commercial In-service date: 2005
- (5) **Fuel**
a. Primary Fuel Natural Gas
b. Alternate Fuel Distillate
- (6) **Air Pollution and Control Strategy:** Dry Low Nox Combustors, Natural Gas, 0.05% S. Distillate, & Water Injection on Distillate
- (7) **Cooling Method:** Cooling Tower
- (8) **Total Site Area:** 460 Acres
- (9) **Construction Status:** P (Planned)
- (10) **Certification Status:** P (Planned)
- (11) **Status with Federal Agencies:** P (Planned)
- (12) **Projected Unit Performance Data ***
Planned Outage Factor (POF): 3%
Forced Outage Factor (FOF): 1%
Equivalent Availability Factor (EAF): 96%
Resulting Capacity Factor (%): 96% (First Year)
Average Net Operating Heat Rate (ANHOR): 7,150 Btu/kWh
- (13) **Projected Unit Financial Data **,*****
Book Life (Years): 25 years
Total Installed Cost (In-Service Year \$/kW): 481.36
Direct Construction Cost (\$/kW): 433.91
AFUDC Amount (\$/kW): 31.29
Escalation (\$/kW): 16.16
Fixed O&M (\$/kW -Yr): 9.30 *
Variable O&M (\$/MWH): 0.74 *
K Factor: 1.5147

* Values represent an operational combined cycle unit after the conversion is completed.

** \$/KW values are based on Summer incremental capacity.

*** Fixed O&M cost includes capital replacement.

Schedule 9
Status Report and Specifications of Proposed Generating Facilities

- (1) **Plant Name and Unit Number:** Midway Combined Cycle
- (2) **Capacity**
a. Summer 547 MW
b. Winter 596 MW
- (3) **Technology Type:** Combined Cycle
- (4) **Anticipated Construction Timing**
a. Field construction start-date: 2002
b. Commercial In-service date: 2005
- (5) **Fuel**
a. Primary Fuel Natural Gas
b. Alternate Fuel Distillate
- (6) **Air Pollution and Control Strategy:** Dry Low Nox Combustors, Natural Gas, 0.05% S. Distillate, & Water Injection on Distillate
- (7) **Cooling Method:** Grey water or groundwater
- (8) **Total Site Area:** 122 Acres
- (9) **Construction Status:** P (Planned)
- (10) **Certification Status:** P (Planned)
- (11) **Status with Federal Agencies:** P (Planned)
- (12) **Projected Unit Performance Data:**
Planned Outage Factor (POF): 3%
Forced Outage Factor (FOF): 1%
Equivalent Availability Factor (EAF): 96%
Resulting Capacity Factor (%): 96% (First Year)
Average Net Operating Heat Rate (ANHOR): 7,150 Btu/kWh
- (13) **Projected Unit Financial Data *,****
Book Life (Years): 25 years
Total Installed Cost (In-Service Year \$/kW): 439.57
Direct Construction Cost (\$/kW): 362.93
AFUDC Amount (\$/kW): 68.27
Escalation (\$/kW): 8.37
Fixed O&M (\$/kW -Yr.): 9.30
Variable O&M (\$/MWH): 0.74
K Factor: 1.5457

* \$/KW values are based on Summer capacity.

** Fixed O&M cost includes capital replacement.

Schedule 9
Status Report and Specifications of Proposed Generating Facilities

- (1) **Plant Name and Unit Number:** Martin No 6
- (2) **Capacity**
a. Summer 547 MW
b. Winter 596 MW
- (3) **Technology Type:** Combined Cycle
- (4) **Anticipated Construction Timing**
a. Field construction start-date: 2003
b. Commercial In-service date: 2006
- (5) **Fuel**
a. Primary Fuel Natural Gas
b. Alternate Fuel Distillate
- (6) **Air Pollution and Control Strategy:** Dry Low Nox Combustors, Natural Gas, 0.05% S. Distillate, & Water Injection on Distillate
- (7) **Cooling Method:** Cooling Pond
- (8) **Total Site Area:** 11,300 Acres
- (9) **Construction Status:** P (Planned)
- (10) **Certification Status:** P (Planned)
- (11) **Status with Federal Agencies:** P (Planned)
- (12) **Projected Unit Performance Data:**
Planned Outage Factor (POF): 3%
Forced Outage Factor (FOF): 1%
Equivalent Availability Factor (EAF): 96%
Resulting Capacity Factor (%): 96% (First Year)
Average Net Operating Heat Rate (ANHOR): 7,150 Btu/kWh
- (13) **Projected Unit Financial Data *,****
Book Life (Years): 25 years
Total Installed Cost (In-Service Year \$/kW): 454.41
Direct Construction Cost (\$/kW): 367.96
AFUDC Amount (\$/kW): 71.07
Escalation (\$/kW): 15.38
Fixed O&M (\$/kW -Yr.): 9.30
Variable O&M (\$/MWH): 0.74
K Factor: 1.5460

* \$/KW values are based on Summer capacity.

** Fixed O&M cost includes capital replacement.

Schedule 9
Status Report and Specifications of Proposed Generating Facilities

- (1) **Plant Name and Unit Number:** Unsited Combined Cycle No. 1
- (2) **Capacity**
a. Summer 547 MW
b. Winter 596 MW
- (3) **Technology Type:** Combined Cycle
- (4) **Anticipated Construction Timing**
a. Field construction start-date: 2004
b. Commercial In-service date: 2007
- (5) **Fuel**
a. Primary Fuel Natural Gas
b. Alternate Fuel Distillate
- (6) **Air Pollution and Control Strategy:** Dry Low Nox Combustors, Natural Gas, 0.05% S. Distillate, & Water Injection on Distillate
- (7) **Cooling Method:** Unknown
- (8) **Total Site Area:** Unknown Acres
- (9) **Construction Status:** P (Planned)
- (10) **Certification Status:** P (Planned)
- (11) **Status with Federal Agencies:** P (Planned)
- (12) **Projected Unit Performance Data:**
Planned Outage Factor (POF): 3%
Forced Outage Factor (FOF): 1%
Equivalent Availability Factor (EAF): 96%
Resulting Capacity Factor (%): 96% (First Year)
Average Net Operating Heat Rate (ANHOR): 7,150 Btu/kWh
- (13) **Projected Unit Financial Data *,****
Book Life (Years): 25 years
Total Installed Cost (In-Service Year \$/kW): 532.83
Direct Construction Cost (\$/kW): 419.24
AFUDC Amount (\$/kW): 85.38
Escalation (\$/kW): 28.21
Fixed O&M (\$/kW -Yr.): 12.10
Variable O&M (\$/MWH): 0.74
K Factor: 1.5473

* \$/KW values are based on Summer capacity.

** Fixed O&M cost includes capital replacement.

Schedule 9
Status Report and Specifications of Proposed Generating Facilities

- (1) **Plant Name and Unit Number:** Unsited Combined Cycle No. 2
- (2) **Capacity**
a. Summer 547 MW
b. Winter 596 MW
- (3) **Technology Type:** Combined Cycle
- (4) **Anticipated Construction Timing**
a. Field construction start-date: 2006
b. Commercial In-service date: 2009
- (5) **Fuel**
a. Primary Fuel Natural Gas
b. Alternate Fuel Distillate
- (6) **Air Pollution and Control Strategy:** Dry Low Nox Combustors, Natural Gas, 0.05% S. Distillate, & Water Injection on Distillate
- (7) **Cooling Method:** Unknown
- (8) **Total Site Area:** Unknown Acres
- (9) **Construction Status:** P (Planned)
- (10) **Certification Status:** P (Planned)
- (11) **Status with Federal Agencies:** P (Planned)
- (12) **Projected Unit Performance Data:**
Planned Outage Factor (POF): 3%
Forced Outage Factor (FOF): 1%
Equivalent Availability Factor (EAF): 96%
Resulting Capacity Factor (%): 96% (First Year)
Average Net Operating Heat Rate (ANHOR): 7,150 Btu/kWh
- (13) **Projected Unit Financial Data **,***
Book Life (Years): 25 years
Total Installed Cost (In-Service Year \$/kW): 554.71
Direct Construction Cost (\$/kW): 419.24
AFUDC Amount (\$/kW): 88.86
Escalation (\$/kW): 46.61
Fixed O&M (\$/kW -Yr.): 12.10
Variable O&M (\$/MWH): 0.74
K Factor: 1.5473

* \$/KW values are based on Summer capacity.

** Fixed O&M cost includes capital replacement.

Schedule 9
Status Report and Specifications of Proposed Generating Facilities

- (1) **Plant Name and Unit Number:** Unsited Combined Cycle No. 3, No. 4, and No. 5 *
- (2) **Capacity**
a. Summer 547 MW
b. Winter 596 MW
- (3) **Technology Type:** Combined Cycle
- (4) **Anticipated Construction Timing**
a. Field construction start-date 2007
b. Commercial In-service date: 2010
- (5) **Fuel**
a. Primary Fuel Natural Gas
b. Alternate Fuel Distillate
- (6) **Air Pollution and Control Strategy:** Dry Low Nox Combustors, Natural Gas, 0.05% S Distillate, & Water Injection on Distillate
- (7) **Cooling Method:** Unknown
- (8) **Total Site Area:** Unknown Acres
- (9) **Construction Status:** P (Planned)
- (10) **Certification Status:** P (Planned)
- (11) **Status with Federal Agencies:** P (Planned)
- (12) **Projected Unit Performance Data:**
Planned Outage Factor (POF): 3%
Forced Outage Factor (FOF): 1%
Equivalent Availability Factor (EAF): 96%
Resulting Capacity Factor (%): 96% (First Year)
Average Net Operating Heat Rate (ANHOR): 7,150 Btu/kWh
- (13) **Projected Unit Financial Data **,*****
Book Life (Years): 25 years
Total Installed Cost (In-Service Year \$/kW): 566.41
Direct Construction Cost (\$/kW): 419.24
AFUDC Amount (\$/kW): 90.72
Escalation (\$/kW): 56.45
Fixed O&M (\$/kW -Yr.): 12.10
Variable O&M (\$/MWH): 0.74
K Factor: 1.5473

* Values shown are per unit values for the three units being added.

** \$/KW values are based on Summer capacity.

*** Fixed O&M cost includes capital replacement.

Schedule 10
Status Report and Specifications of Proposed Integrated Transmission Lines

Martin: 2 CT's

- | | | |
|-----|-------------------------------------|--|
| (1) | Point of Origin and Termination: | Not Applicable |
| (2) | Number of Lines: | Not Applicable |
| (3) | Right-of-way | FPL Owned |
| (4) | Line Length: | Not Applicable |
| (5) | Voltage: | Not Applicable |
| (6) | Anticipated Construction Timing: | Start date: Not Applicable
End date: Not Applicable |
| (7) | Anticipated Capital Investment: | Not Applicable |
| (8) | Substations: | Not Applicable |
| (9) | Participation with Other Utilities: | None |

Schedule 10
Status Report and Specifications of Proposed Integrated Transmission Lines

Ft. Myers Repowering

(1)	Point of Origin and Termination:	From Ft. Myers – To Calusa
(2)	Number of Lines:	1
(3)	Right-of-way	FPL Owned
(4)	Line Length:	1.58 miles
(5)	Voltage:	230 kV
(6)	Anticipated Construction Timing:	Start date: May 1, 2000 End date: April 1, 2001
(7)	Anticipated Capital Investment:	\$354,000
(8)	Substations:	Ft. Myers and Calusa
(9)	Participation with Other Utilities:	None

(1)	Point of Origin and Termination:	From Ft. Myers – To Orange River
(2)	Number of Lines:	1
(3)	Right-of-way	FPL Owned
(4)	Line Length:	2.57 miles
(5)	Voltage:	230 kV
(6)	Anticipated Construction Timing:	Start date: March 1, 2000 End date: October 1, 2000
(7)	Anticipated Capital Investment:	\$706,750
(8)	Substations:	Ft. Myers and Orange River
(9)	Participation with Other Utilities:	None

Schedule 10
Status Report and Specifications of Proposed Integrated Transmission Lines

Sanford Repowering

- | | | |
|-----|-------------------------------------|---|
| (1) | Point of Origin and Termination: | From Sanford – To Poinsett |
| (2) | Number of Lines: | 2 |
| (3) | Right-of-way | FPL Owned |
| (4) | Line Length: | 45 miles |
| (5) | Voltage: | 230 kV |
| (6) | Anticipated Construction Timing: | Start date: January 1, 2001
End date: June 1, 2001 |
| (7) | Anticipated Capital Investment: | \$20,360,000 |
| (8) | Substations: | Sanford and Poinsett |
| (9) | Participation with Other Utilities: | None |

Schedule 10
Status Report and Specifications of Proposed Integrated Transmission Lines

Ft. Myers: 2 CT's

- | | |
|---|--|
| (1) Point of Origin and Termination: | From Ft. Myers GT Collector bus – To Orange River |
| (2) Number of Lines: | 1 |
| (3) Right-of-way | FPL Owned |
| (4) Line Length: | 2.5 miles |
| (5) Voltage: | 230 kV |
| (6) Anticipated Construction Timing: | Start date: January 1, 2003
End date: May 1, 2003 |
| (7) Anticipated Capital Investment: | \$1,050,000 |
| (8) Substations: | Orange River and Ft. Myers GT collector bus |
| (9) Participation with Other Utilities: | None |

Schedule 10
Status Report and Specifications of Proposed Integrated Transmission Lines

Martin 5

- | | | |
|-----|-------------------------------------|---|
| (1) | Point of Origin and Termination: | a. From Pratt & Whitney – To Indiantown
b. From Pratt & Whitney – To Ranch
c. From Martin – To Indiantown |
| (2) | Number of Lines: | 3 |
| (3) | Right-of-way | FPL Owned |
| (4) | Line Length: | a. 8.45 miles
b. 20.74 miles
c. 11.8 miles |
| (5) | Voltage: | 230 kV |
| (6) | Anticipated Construction Timing: | Start date: June 1, 2004
End date: June 1, 2005 |
| (7) | Anticipated Capital Investment: | \$6,725,000 |
| (8) | Substations: | Pratt & Whitney, Ranch, Martin, and Indiantown |
| (9) | Participation with Other Utilities: | None |

Note:The existing lines (a & b) will be upgraded to a higher current rating. The line from Martin to Indiantown (c) will be a new circuit integrated with this project.

Schedule 10
Status Report and Specifications of Proposed Integrated Transmission Lines

Martin: Conversion of CT's into a Combined Cycle Unit

(1)	Point of Origin and Termination:	Not Available
(2)	Number of Lines:	Not Available
(3)	Right-of-way	FPL Owned
(4)	Line Length:	Not Available
(5)	Voltage:	Not Available
(6)	Anticipated Construction Timing:	Start date: Not Available End date: Not Available
(7)	Anticipated Capital Investment:	Not Available
(8)	Substations:	Not Available
(9)	Participation with Other Utilities:	None

Schedule 10
Status Report and Specifications of Proposed Integrated Transmission Lines

Ft. Myers: Conversion of CT's into a Combined Cycle Unit

- | | | |
|-----|-------------------------------------|--|
| (1) | Point of Origin and Termination: | Not Available |
| (2) | Number of Lines: | Not Available |
| (3) | Right-of-way | FPL Owned |
| (4) | Line Length: | Not Available |
| (5) | Voltage: | Not Available |
| (6) | Anticipated Construction Timing: | Start date: Not Available
End date: Not Available |
| (7) | Anticipated Capital Investment: | Not Available |
| (8) | Substations: | Not Available |
| (9) | Participation with Other Utilities: | None |

Schedule 10
Status Report and Specifications of Proposed Integrated Transmission Lines

Midway: Combined Cycle Unit

- | | | |
|-----|-------------------------------------|--|
| (1) | Point of Origin and Termination: | Not Available |
| (2) | Number of Lines: | Not Available |
| (3) | Right-of-way | FPL Owned |
| (4) | Line Length: | Not Available |
| (5) | Voltage: | Not Available |
| (6) | Anticipated Construction Timing: | Start date: Not Available
End date: Not Available |
| (7) | Anticipated Capital Investment: | Not Available |
| (8) | Substations: | Not Available |
| (9) | Participation with Other Utilities: | None |

Schedule 10
Status Report and Specifications of Proposed Integrated Transmission Lines

Martin 6

- | | | |
|-----|-------------------------------------|--|
| (1) | Point of Origin and Termination: | Not Applicable |
| (2) | Number of Lines: | Not Applicable |
| (3) | Right-of-way | FPL Owned |
| (4) | Line Length: | Not Applicable |
| (5) | Voltage: | Not Applicable |
| (6) | Anticipated Construction Timing: | Start date: Not Applicable
End date: Not Applicable |
| (7) | Anticipated Capital Investment: | Not Applicable |
| (8) | Substations: | Not Applicable |
| (9) | Participation with Other Utilities: | None |

(This page is left intentionally blank.)

Ten Year Site Plan Fact Summary

(This page is left intentionally blank.)

Capacity Resources (as of December 31, 2000)

□ Non-FPL Territory

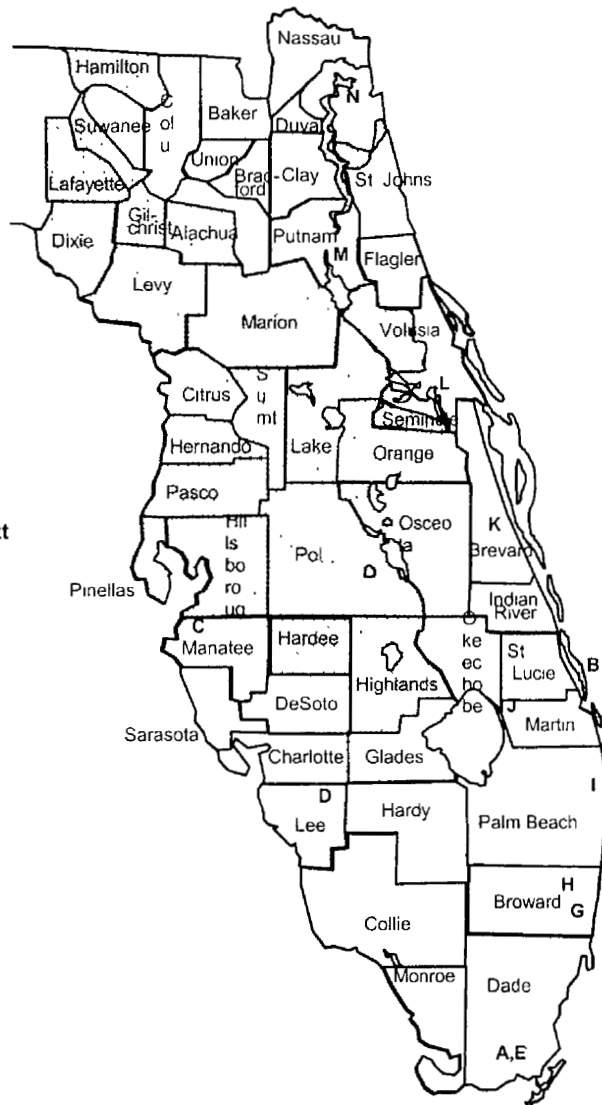

Unit	Units	Fuel Type	Summe Megawatt
A. Turkey Point	2	Nuclear	1,386
B. St. Lucie	2	Nuclear	1,553
C. Manatee	2	Oil	1,625
D. Ft.	2	Oil	543
E. Turkey Point	2	Oil/Ga	810
F. Cutler	2	Gas	215
G. Lauderdale	2	Oil/Ga	854
H. Port Everglades	4	Oil/Ga	1,242
I. Riviera	2	Oil/Ga	563
J. Martin	4	Gas/Oil	2,588
K. Cape Canaveral	2	Oil/Ga	806
L. Sanford	3	Oil/Ga	914
M. Putnam	2	Oil/Ga	498
N. St. Johns River	2	Coal	254
Scherer **	1	Coal	658
Peaking Units			2,355
FPL			16,864

* Represents FPL's ownership share St. Lucie nuclear: 100% unit 1, 85% unit 2; St. Johns River: 20% of two

** The Scherer unit is located in Georgia and is not shown on this map.

	2000 Actual	2001 Projection	2010 Projection
--	----------------	--------------------	--------------------

Average Number of Customers Source: FPL Schedule 2			
Residential	3,414,002	3,471,810	4,003,154
Commercial	415,295	426,053	512,269
Industrial	16,410	15,631	16,280
Other	2,694	2,604	2,577
Total:	3,848,401	3,916,098	4,534,280

Peak Demand Source: FPL Schedule 4			
Winter	17,057	18,840	19,333
Summer	17,808	18,150	18,801

Installed Capability (MW) Source: FPL Schedule 7.1 & 7.2			
Winter	17,750	17,785	23,957
Summer	16,684	17,704	24,093

Number Of Substations

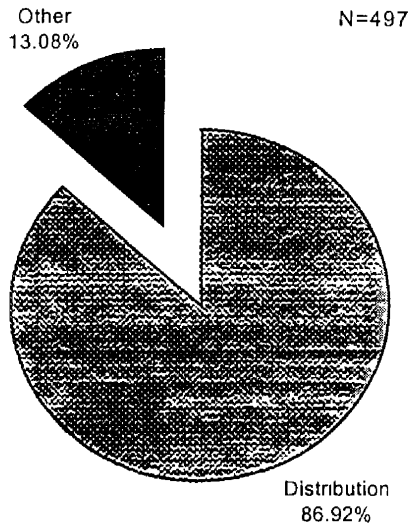

Miles of Lines

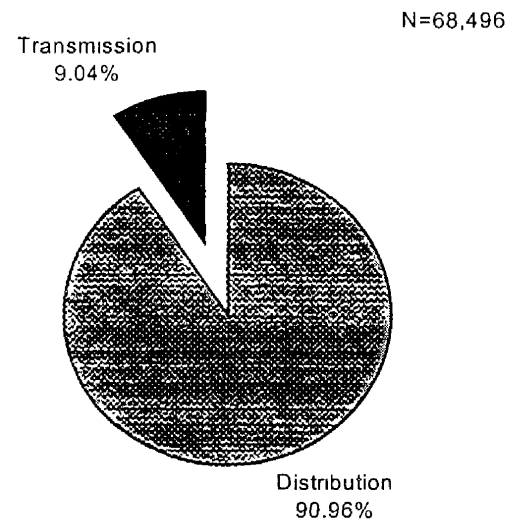

Miles of Bulk Transmission Lines (By Voltage Level)

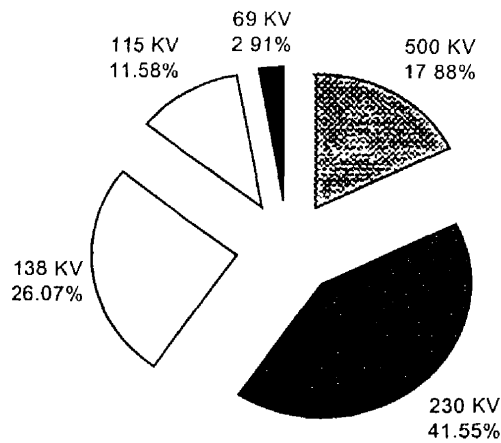

GENERATION RESOURCES

	2000 Actual	2001 Projection	2010 Projection
Facilities Source: FPL Schedule 5			
Coal 1,000 Ton	4,170	3,788	3,821
Oil 1,000 BBL	37,320	33,274	9,234
Gas 1,000 MCF	203,234	248,439	519,426
Nuclear Trillion BTU	268	257	257

INSTALLED GENERATION MW BY FUEL TYPE

2000

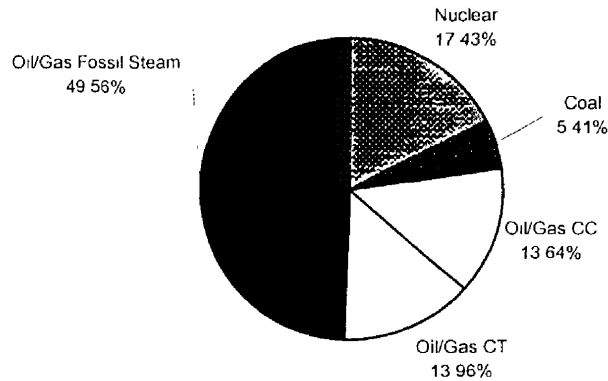

2010

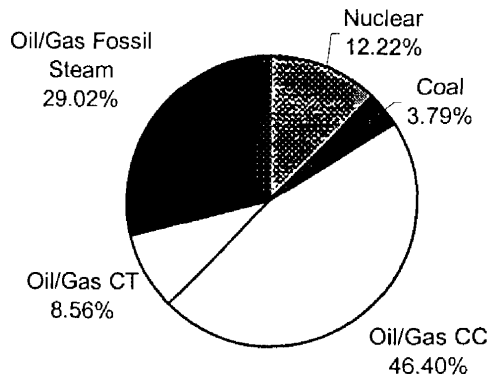

NET ENERGY FOR LOAD

	2000 Actual	2001 Projection	2010 Projection
Consumption (GWH) Source: FPL Schedule 2			
Residential	46,320	46,949	54,952
Commercial	37,001	39,840	49,516
Industrial	3,768	3,953	4,199
Other	870	986	1,100
Sales For Resale	970	992	1,073
Losses	7,059	6,837	8,607
Total:	87,959	91,728	109,767

NET ENERGY FOR LOAD

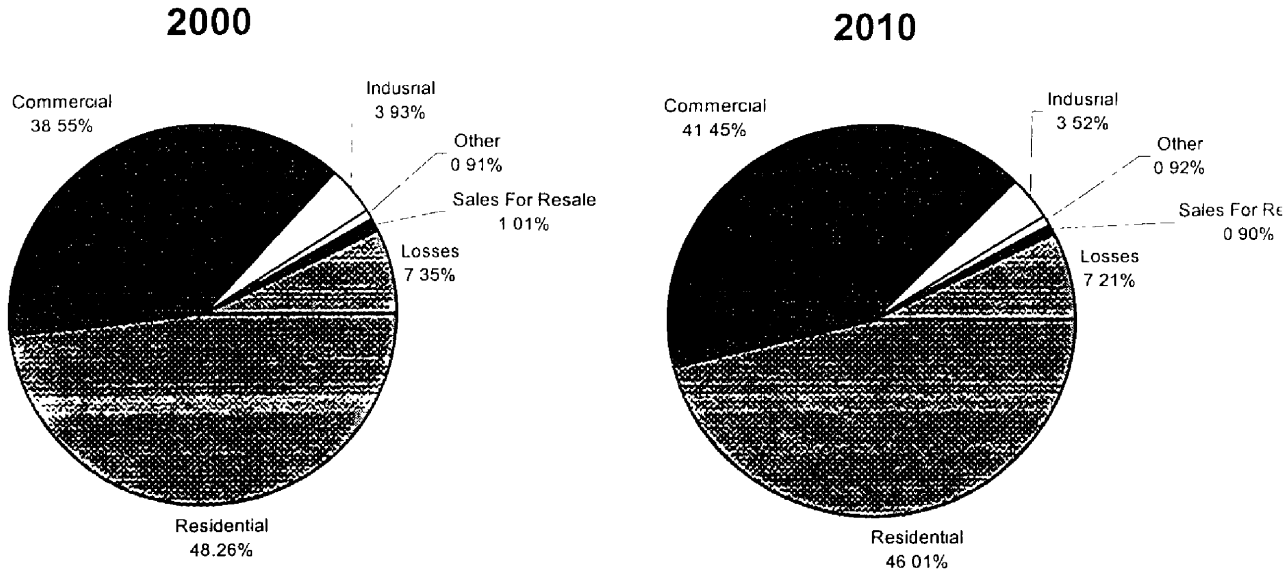

	2000 Actual	2001 Projection	2010 Projection
Per Capita Consumption (KWH) Source: FPL Schedule 2			
Residential	13,568	13,523	13,727
Commercial	89,096	93,508	96,660
Industrial	229,592	252,888	257,919

ENERGY BY FUEL TYPE

	2000 Actual	2001 Projection	2010 Projection
--	----------------	--------------------	--------------------

Energy By Fuel Type (GWH)	Source: FPL Schedule 6.1		
FPL Facilities			
Coal-Fired	6,977	6,906	6,995
Oil-Fired	23,423	20,919	6,224
Gas-Fired	24,217	28,259	71,987
Nuclear	24,584	23,776	23,778
QFs	9,345	7,260	2,482
Net Energy Interchange	7,443	12,366	6,771
Net Energy For Load (NEL)	95,989	99,486	118,237

2000

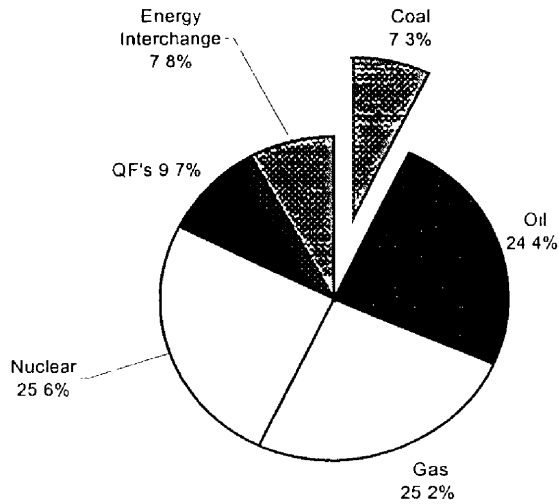

2010

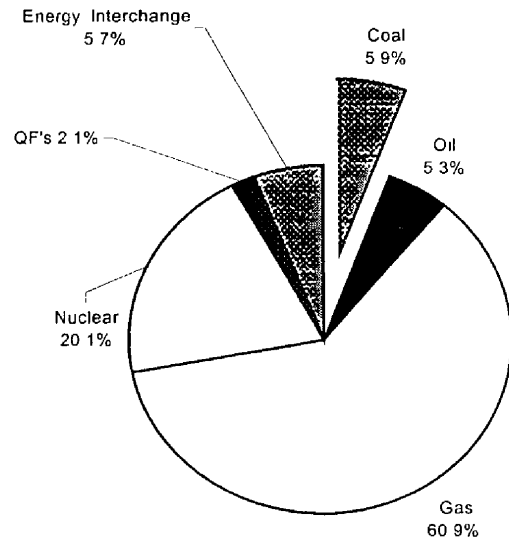

(This page is left intentionally blank.)