

BellSouth Telecommunications, Inc.
Suite 400
150 South Monroe Street
Tallahassee, FL 32301-1556

marshall.criser@bellsouth.com

Marshall M. Criser III
Vice President
Regulatory & External Affairs

850 224 7798
Fax 850 224 5073

December 19, 2001

Mrs. Blanca S. Bayo
Director, Division of the Commission Clerk and Administrative Services
Florida Public Service Commission
2540 Shumard Oak Boulevard
Tallahassee, Florida 32399

011667-TP

Re: Approval of the negotiated Interconnection, Unbundling, Resale, and Collocation agreement between BellSouth Telecommunications, Inc. ("BellSouth") and Heritage Technologies, Ltd. pursuant to Sections 251, 252 and 271 of the Telecommunications Act of 1996

Dear Mrs. Bayo:

Pursuant to section 252(e) of the Telecommunications Act of 1996, BellSouth and Heritage Technologies, Ltd. are submitting to the Florida Public Service Commission their negotiated Interconnection, Unbundling, Resale, and Collocation agreement for the interconnection, resale and collocation of their networks, the unbundling of specific network elements offered by BellSouth and the resale of BellSouth telecommunications services to Heritage Technologies, Ltd.. The agreement was negotiated pursuant to sections 251, 252 and 271 of the Act.

Pursuant to section 252(e) of the Act, the Commission is charged with approving or rejecting the negotiated Interconnection, Unbundling, Resale, and Collocation agreement between BellSouth and Heritage Technologies, Ltd. within 90 days of its submission. The Commission may only reject such an agreement if it finds that the agreement or any portion of the agreement discriminates against a telecommunications carrier not a party to the agreement or the implementation of the agreement or any portion of the agreement is not consistent with the public interest, convenience and necessity. Both parties represent that neither of these reasons exists as to the agreement they have negotiated and that the Commission should approve their agreement, and as such this agreement will be deemed effective by operation of law on March 18, 2002.

Very truly yours,

Regulatory Vice President (RA)

DOCUMENT NUMBER-DATE
15891 DEC 20 2001
FPSC-COMMISSION CLERK.

32

**INTERCONNECTION
AGREEMENT
BETWEEN
BELLSOUTH TELECOMMUNICATIONS INC.
AND
Heritage Technologies, Ltd.**

TABLE OF CONTENTS

General Terms and Conditions

- Definitions
- 1. CLEC Certification
- 2. Term of the Agreement
- 3. Operational Support Systems
- 4. Parity
- 5. White Pages Listings
- 6. Bona Fide Request/New Business Request Process for Further Unbundling
- 7. Court Ordered Requests for Call Detail Records and Other Subscriber Information
- 8. Liability and Indemnification
- 9. Intellectual Property Rights and Indemnification
- 10. Proprietary and Confidential Information
- 11. Resolution of Disputes
- 12. Taxes
- 13. Force Majeure
- 14. Adoption of Agreements
- 15. Modification of Agreement
- 16. Non-waiver of Legal Rights
- 17. Severability
- 18. Waivers
- 19. Governing Law
- 20. Arm's Length Negotiations
- 21. Notices
- 22. Rule of Construction
- 23. Headings of No Force or Effect
- 24. Multiple Counterparts
- 25. Implementation of Agreement
- 26. Filing of Agreement
- 27. Compliance with Applicable Law
- 28. Necessary Approvals
- 29. Good Faith Performance
- 30. Nonexclusive Dealings
- 31. Rate True-Up
- 32. Survival
- 33. Establishment of Service
- 34. Entire Agreement

TABLE OF CONTENTS (cont'd)

Attachment 1 - Resale

Attachment 2 - Network Elements and Other Services

Attachment 3 - Network Interconnection

Attachment 4 - Physical Collocation

Attachment 5 - Access to Numbers and Number Portability

Attachment 6 – Pre-Ordering, Ordering and Provisioning, Maintenance and Repair

Attachment 7 - Billing and Billing Accuracy Certification

Attachment 8 - Rights-of-Way, Conduits and Pole Attachments

Attachment 9 - Performance Measurements

Attachment 10- Agreement Implementation Template

Attachment 11- BellSouth Disaster Recovery Plan

Attachment 12 – Bona Fide Request/New Business Request Process

AGREEMENT

THIS AGREEMENT is made by and between BellSouth Telecommunications, Inc., (“BellSouth”), a Georgia corporation, and Heritage Technologies, Ltd. (“Heritage”), a Texas limited partnership, and shall be deemed effective as of the date of the last signature of both Parties (“Effective Date”). This Agreement may refer to either BellSouth or Heritage or both as a “Party” or “Parties.”

WITNESSETH

WHEREAS, BellSouth is a local exchange telecommunications company authorized to provide telecommunications services in the states of Alabama, Florida, Georgia, Kentucky, Louisiana, Mississippi, North Carolina, South Carolina and Tennessee; and

WHEREAS, Heritage is or seeks to become a CLEC authorized to provide telecommunications services in the state of Florida; and

WHEREAS, Heritage wishes to resell BellSouth’s telecommunications services and purchase network elements and other services, and the Parties wish to interconnect their facilities and exchange traffic pursuant to Sections 251 and 252 of the Act.

NOW THEREFORE, in consideration of the mutual agreements contained herein, BellSouth and Heritage agree as follows:

Definitions

Affiliate is defined as a person that (directly or indirectly) owns or controls, is owned or controlled by, or is under common ownership or control with, another person. For purposes of this paragraph, the term “own” means to own an equity interest (or equivalent thereof) of more than 10 percent.

Commission is defined as the appropriate regulatory agency in each of BellSouth’s nine-state region, Alabama, Florida, Georgia, Kentucky, Louisiana, Mississippi, North Carolina, South Carolina, and Tennessee.

Competitive Local Exchange Carrier (CLEC) means a telephone company certificated by the Commission to provide local exchange service within BellSouth's franchised area.

End User means the ultimate user of the Telecommunications Service.

FCC means the Federal Communication Commission.

Telecommunications means the transmission, between or among points specified by the user, of information of the user's choosing, without change in the form or content of the information as sent and received.

Telecommunications Service means the offering of telecommunications for a fee directly to the public, or to such classes of users as to be effectively available directly to the public, regardless of the facilities used.

Telecommunications Act of 1996 ("Act") means Public Law 104-104 of the United States Congress effective February 8, 1996. The Act amended the Communications Act of 1934 (47 U.S.C. Section 1 et. seq.).

1. CLEC Certification

1.1 Heritage agrees to provide BellSouth in writing the certificate number or docket number, for the docket pending certification, for all states covered by this Agreement except Kentucky prior to BellSouth filing this Agreement with the appropriate commission for approval.

1.2 Additionally, Heritage will notify BellSouth in writing when it becomes certified or has a docket pending certification to operate in any other state in the BellSouth region. Upon notification, BellSouth will file this Agreement with the appropriate commission for approval.

2. Term of the Agreement

2.1 The term of this Agreement shall be three years, beginning on the Effective Date and shall apply to the BellSouth territory in the state of Florida.

2.2 The Parties agree that by no earlier than two hundred seventy (270) days and no later than one hundred and eighty (180) days prior to the expiration of this Agreement, they shall commence negotiations for a new agreement to be effective beginning on the expiration date of this Agreement ("Subsequent Agreement"). If as of the expiration of this Agreement, a Subsequent Agreement has not been executed by the Parties, then except as set forth in Section 2.3.2 below, this Agreement shall continue on a month-to-month basis while a Subsequent Agreement is being negotiated. The Parties' rights and obligations with respect to this Agreement after expiration shall be as set forth in Section 2.3 below.

2.3 If, within one hundred and thirty-five (135) days of commencing the negotiation referred to in Section 2.2 above, the Parties are unable to negotiate new terms, conditions and prices for a Subsequent Agreement, either Party may petition the Commission to establish appropriate terms, conditions and prices for the Subsequent Agreement pursuant to 47 U.S.C. 252. In the event the Commission does not issue its order prior to the expiration date of this Agreement, or if the Parties continue beyond the expiration date of this Agreement to negotiate the Subsequent Agreement without Commission intervention, the terms, conditions

and prices ultimately ordered by the Commission, or negotiated by the Parties, shall be effective as of the date of execution of this agreement.

- 2.3.1 Except as set forth in Section 2.3.2 below, notwithstanding the foregoing, in the event that as of the date of expiration of this Agreement and conversion of this Agreement to a month-to-month term, the Parties have not entered into a Subsequent Agreement and no arbitration proceeding has been filed in accordance with Section 2.3 above, then either Party may terminate this Agreement upon sixty (60) days notice to the other Party. In the event that BellSouth terminates this Agreement as provided above, BellSouth shall continue to offer services to Heritage pursuant to the terms, conditions and rates set forth in BellSouth's then current standard interconnection agreement. In the event that BellSouth's standard interconnection agreement becomes effective as between the Parties, the Parties may continue to negotiate a Subsequent Agreement, and the terms of such Subsequent Agreement shall be effective as of the date of execution.
- 2.3.2 Notwithstanding Section 2.3 above, in the event that as of the date of expiration of this Agreement the Parties have not entered into a Subsequent Agreement and (1) no arbitration proceeding has been filed in accordance with Section 2.2 above, and (2) Heritage either is not certified as a CLEC in any particular state to which this Agreement applies or has not ordered any services under this Agreement as of the date of expiration, then this Agreement shall not continue on a month to month basis but shall be deemed terminated as of the expiration date hereof.

3. Operational Support Systems

- 3.1 Heritage shall pay charges for Operational Support Systems (OSS) as set forth in this Agreement in Attachment 1 and/or in Attachments 2, 3 and 5, as applicable.

4. Parity

- 4.1 When Heritage purchases, pursuant to Attachment 1 of this Agreement, telecommunications services from BellSouth for the purposes of resale to end users, BellSouth shall provide said services so that the services are equal in quality, subject to the same conditions, and provided within the same provisioning time intervals that BellSouth provides to its affiliates, subsidiaries and end users. To the extent technically feasible, the quality of a Network Element, as well as the quality of the access to such Network Element provided by BellSouth to Heritage shall be at least equal in quality to that which BellSouth provides to itself, its affiliates or any other telecommunications carrier. The quality of the interconnection between the networks of BellSouth and the network of Heritage shall be at a level that is equal to that which BellSouth provides itself, a subsidiary, an Affiliate, or any other party. The interconnection facilities shall be designed to meet the same technical criteria and service standards that are used within BellSouth's network and shall extend to a consideration of service quality as perceived by BellSouth's end users and service quality as perceived by Heritage.

- 5. White Pages Listings**
- 5.1 BellSouth shall provide Heritage and their customers access to white pages directory listings under the following terms:
- 5.2 Listings. Heritage shall provide all new, changed and deleted listings on a timely basis and BellSouth or its agent will include Heritage residential and business customer listings in the appropriate White Pages (residential and business) or alphabetical directories. Directory listings will make no distinction between Heritage and BellSouth subscribers.
- 5.2.1 Rates. So long as Heritage provides subscriber listing information to BellSouth in accordance with Section 5.3 below, BellSouth shall provide to Heritage one (1) primary White Pages listing per Heritage subscriber at no charge other than applicable service order charges as set forth in BellSouth's tariffs.
- 5.3 Procedures for Submitting Heritage Subscriber Information are found in The BellSouth Business Rules for Local Ordering.
- 5.3.1 Notwithstanding any provision(s) to the contrary, Heritage shall provide to BellSouth, and BellSouth shall accept, Heritage's Subscriber Listing Information (SLI) relating to Heritage's customers in the geographic area(s) covered by this Interconnection Agreement. Heritage authorizes BellSouth to release all such Heritage SLI provided to BellSouth by Heritage to qualifying third parties via either license agreement or BellSouth's Directory Publishers Database Service (DPDS), General Subscriber Services Tariff, Section A38.2, as the same may be amended from time to time. Such Heritage SLI shall be intermingled with BellSouth's own customer listings and listings of any other CLEC that has authorized a similar release of SLI. Where necessary, BellSouth will use good faith efforts to obtain state commission approval of any necessary modifications to Section A38.2 of its tariff to provide for release of third party directory listings, including modifications regarding listings to be released pursuant to such tariff and BellSouth's liability thereunder. BellSouth's obligation pursuant to this Section shall not arise in any particular state until the commission of such state has approved modifications to such tariff.
- 5.3.2 No compensation shall be paid to Heritage for BellSouth's receipt of Heritage SLI, or for the subsequent release to third parties of such SLI. In addition, to the extent BellSouth incurs costs to modify its systems to enable the release of Heritage's SLI, or costs on an ongoing basis to administer the release of Heritage SLI, Heritage shall pay to BellSouth its proportionate share of the reasonable costs associated therewith.
- 5.3.3 Neither BellSouth nor any agent shall be liable for the content or accuracy of any SLI provided by Heritage under this Agreement. Heritage shall indemnify, hold harmless and defend BellSouth and its agents from and against any damages, losses, liabilities, demands claims, suits, judgments, costs and expenses (including

but not limited to reasonable attorneys' fees and expenses) arising from BellSouth's tariff obligations or otherwise and resulting from or arising out of any third party's claim of inaccurate Heritage listings or use of the SLI provided pursuant to this Agreement. BellSouth may forward to Heritage any complaints received by BellSouth relating to the accuracy or quality of Heritage listings.

5.3.4 Listings and subsequent updates will be released consistent with BellSouth system changes and/or update scheduling requirements.

5.4 Unlisted/Non-Published Subscribers. Heritage will be required to provide to BellSouth the names, addresses and telephone numbers of all Heritage customers that wish to be omitted from directories.

5.5 Inclusion of Heritage Customers in Directory Assistance Database. BellSouth will include and maintain Heritage subscriber listings in BellSouth's Directory Assistance databases at no recurring charge and Heritage shall provide such Directory Assistance listings at no recurring charge. BellSouth and Heritage will formulate appropriate procedures regarding lead-time, timeliness, format and content of listing information.

5.6 Listing Information Confidentiality. BellSouth will accord Heritage's directory listing information the same level of confidentiality that BellSouth accords its own directory listing information, and BellSouth shall limit access to Heritage's customer proprietary confidential directory information to those BellSouth employees or agents who are involved in the preparation of listings or directories.

5.7 Additional and Designer Listings. Additional and designer listings will be offered by BellSouth at tariffed rates as set forth in the General Subscriber Services Tariff.

5.8 Directories. BellSouth or its agent shall make available White Pages directories to Heritage subscribers at no charge or as specified in a separate 3APCO agreement.

6. **Bona Fide Request/New Business Request Process for Further Unbundling**

6.1 BellSouth shall, upon request of Heritage, provide to Heritage access to its network elements at any technically feasible point for the provision of Heritage's telecommunications service where such access is necessary and failure to provide access would impair the ability of Heritage to provide services that it seeks to offer. Any request by Heritage for access to a network element, interconnection option, or for the provisioning of any service or product that is not already available shall be treated as a Bona Fide Request/New Business Request (BFR/NBR), and shall be submitted to BellSouth pursuant to the BFR/NBR process as described in Attachment 12 to this Agreement.

6.2 Heritage shall submit any BFR/NBR in writing to Heritage's Account Manager. The BFR/NBR shall specifically identify the requested service date, technical requirements, space requirements and/or such specifications that clearly define the request such that BellSouth has sufficient information to analyze and prepare a

response. The BFR/NBR also shall include Heritage's designation of the request as being (i) pursuant to the Telecommunications Act of 1996 or (ii) pursuant to the needs of the business.

7. Court Ordered Requests for Call Detail Records and Other Subscriber Information

7.1 Subpoenas Directed to BellSouth. Where BellSouth provides resold services or local switching for Heritage, BellSouth shall respond to subpoenas and court ordered requests delivered directly to BellSouth for the purpose of providing call detail records when the targeted telephone numbers belong to Heritage end users. Billing for such requests will be generated by BellSouth and directed to the law enforcement agency initiating the request. BellSouth shall maintain such information for Heritage end users for the same length of time it maintains such information for its own end users.

7.2 Subpoenas Directed to Heritage. Where BellSouth is providing to Heritage telecommunications services for resale or providing to Heritage the local switching function, then Heritage agrees that in those cases where Heritage receives subpoenas or court ordered requests regarding targeted telephone numbers belonging to Heritage end users, and where Heritage does not have the requested information, Heritage will advise the law enforcement agency initiating the request to redirect the subpoena or court ordered request to BellSouth for handling in accordance with 7.1 above.

7.3 In all other instances, where either Party receives a request for information involving the other Party's end user, the Party receiving the request will advise the law enforcement agency initiating the request to redirect such request to the other Party.

8. Liability and Indemnification

8.1 Heritage Liability. In the event that Heritage consists of two (2) or more separate entities as set forth in this Agreement and/or any Amendments hereto, all such entities shall be jointly and severally liable for the obligations of Heritage under this Agreement.

8.2 Liability for Acts or Omissions of Third Parties. BellSouth shall not be liable to Heritage for any act or omission of another telecommunications company providing services to Heritage.

8.3 Limitation of Liability

8.3.1 Except for any indemnification obligations of the Parties hereunder, each Party's liability to the other for any loss, cost, claim, injury or liability or expense, including reasonable attorney's fees relating to or arising out of any negligent act or omission in its performance of this Agreement whether in contract or in tort,

shall be limited to a credit for the actual cost of the services or functions not performed or improperly performed.

- 8.3.2 **Limitations in Tariffs.** A Party may, in its sole discretion, provide in its tariffs and contracts with its End Users and third parties that relate to any service, product or function provided or contemplated under this Agreement, that to the maximum extent permitted by Applicable Law, such Party shall not be liable to the End User or third Party for (i) any loss relating to or arising out of this Agreement, whether in contract, tort or otherwise, that exceeds the amount such Party would have charged that applicable person for the service, product or function that gave rise to such loss and (ii) Consequential Damages. To the extent that a Party elects not to place in its tariffs or contracts such limitations of liability, and the other Party incurs a loss as a result thereof, such Party shall indemnify and reimburse the other Party for that portion of the loss that would have been limited had the first Party included in its tariffs and contracts the limitations of liability that such other Party included in its own tariffs at the time of such loss.
- 8.3.3 Neither BellSouth nor Heritage shall be liable for damages to the other Party's terminal location, equipment or End User premises resulting from the furnishing of a service, including, but not limited to, the installation and removal of equipment or associated wiring, except to the extent caused by a Party's negligence or willful misconduct or by a Party's failure to ground properly a local loop after disconnection.
- 8.3.4 Under no circumstance shall a Party be responsible or liable for indirect, incidental, or consequential damages, including, but not limited to, economic loss or lost business or profits, damages arising from the use or performance of equipment or software, or the loss of use of software or equipment, or accessories attached thereto, delay, error, or loss of data. In connection with this limitation of liability, each Party recognizes that the other Party may, from time to time, provide advice, make recommendations, or supply other analyses related to the Services, or facilities described in this Agreement, and, while each Party shall use diligent efforts in this regard, the Parties acknowledge and agree that this limitation of liability shall apply to provision of such advice, recommendations, and analyses.
- 8.3.5 To the extent any specific provision of this Agreement purports to impose liability, or limitation of liability, on either Party different from or in conflict with the liability or limitation of liability set forth in this Section, then with respect to any facts or circumstances covered by such specific provisions, the liability or limitation of liability contained in such specific provision shall apply.
- 8.4 **Indemnification for Certain Claims.** The Party providing services hereunder, its affiliates and its parent company, shall be indemnified, defended and held harmless by the Party receiving services hereunder against any claim, loss or damage arising from the receiving company's use of the services provided under this Agreement pertaining to (1) claims for libel, slander or invasion of privacy arising from the content of the receiving company's own communications, or (2) any claim, loss or

damage claimed by the End User of the Party receiving services arising from such company's use or reliance on the providing company's services, actions, duties, or obligations arising out of this Agreement.

- 8.5 **Disclaimer.** EXCEPT AS SPECIFICALLY PROVIDED TO THE CONTRARY IN THIS AGREEMENT, NEITHER PARTY MAKES ANY REPRESENTATIONS OR WARRANTIES TO THE OTHER PARTY CONCERNING THE SPECIFIC QUALITY OF ANY SERVICES, OR FACILITIES PROVIDED UNDER THIS AGREEMENT. THE PARTIES DISCLAIM, WITHOUT LIMITATION, ANY WARRANTY OR GUARANTEE OF MERCHANTABILITY OR FITNESS FOR A PARTICULAR PURPOSE, ARISING FROM COURSE OF PERFORMANCE, COURSE OF DEALING, OR FROM USAGES OF TRADE.

9. **Intellectual Property Rights and Indemnification**

- 9.1 **No License.** No patent, copyright, trademark or other proprietary right is licensed, granted or otherwise transferred by this Agreement. Heritage is strictly prohibited from any use, including but not limited to in sales, in marketing or advertising of telecommunications services, of any BellSouth name, service mark or trademark. Notwithstanding the foregoing, Heritage may use BellSouth's name solely in response to inquiries of customers or potential customers regarding the source of the underlying service or the identity of repair or service technicians under this Agreement.

- 9.2 **Ownership of Intellectual Property.** Any intellectual property which originates from or is developed by a Party shall remain the exclusive property of that Party. Except for a limited license to use patents or copyrights to the extent necessary for the Parties to use any facilities or equipment (including software) or to receive any service solely as provided under this Agreement, no license in patent, copyright, trademark or trade secret, or other proprietary or intellectual property right now or hereafter owned, controlled or licensable by a Party, is granted to the other Party or shall be implied or arise by estoppel. It is the responsibility of each Party to ensure at no additional cost to the other Party that it has obtained any necessary licenses in relation to intellectual property of third Parties used in its network that may be required to enable the other Party to use any facilities or equipment (including software), to receive any service, or to perform its respective obligations under this Agreement.

- 9.3 **Indemnification.** The Party providing a service pursuant to this Agreement will defend the Party receiving such service or data provided as a result of such service against claims of infringement arising solely from the use by the receiving Party of such service in the manner contemplated under this Agreement and will indemnify the receiving Party for any damages awarded based solely on such claims in accordance with Section 8 preceding.

- 9.4 **Claim of Infringement.** In the event that use of any facilities or equipment (including software), becomes, or in the reasonable judgment of the Party who owns the affected network is likely to become, the subject of a claim, action, suit, or proceeding based on intellectual property infringement, then said Party shall promptly and at its sole expense and sole option, but subject to the limitations of liability set forth below:
- 9.4.1 modify or replace the applicable facilities or equipment (including software) while maintaining form and function, or
- 9.4.2 obtain a license sufficient to allow such use to continue.
- 9.4.3 In the event 9.4.1 or 9.4.2 are commercially unreasonable, then said Party may, terminate, upon reasonable notice, this contract with respect to use of, or services provided through use of, the affected facilities or equipment (including software), but solely to the extent required to avoid the infringement claim.
- 9.5 **Exception to Obligations.** Neither Party's obligations under this Section shall apply to the extent the infringement is caused by: (i) modification of the facilities or equipment (including software) by the indemnitee; (ii) use by the indemnitee of the facilities or equipment (including software) in combination with equipment or facilities (including software) not provided or authorized by the indemnitor, provided the facilities or equipment (including software) would not be infringing if used alone; (iii) conformance to specifications of the indemnitee which would necessarily result in infringement; or (iv) continued use by the indemnitee of the affected facilities or equipment (including software) after being placed on notice to discontinue use as set forth herein.
- 9.6 **Exclusive Remedy.** The foregoing shall constitute the Parties' sole and exclusive remedies and obligations with respect to a third party claim of intellectual property infringement arising out of the conduct of business under this Agreement.
10. **Proprietary and Confidential Information**
- 10.1 **Proprietary and Confidential Information.** It may be necessary for BellSouth and Heritage, each as the "Discloser," to provide to the other Party, as "Recipient," certain proprietary and confidential information (including trade secret information) including but not limited to technical, financial, marketing, staffing and business plans and information, strategic information, proposals, request for proposals, specifications, drawings, maps, prices, costs, costing methodologies, procedures, processes, business systems, software programs, techniques, customer account data, call detail records and like information (collectively the "Information"). All such Information conveyed in writing or other tangible form shall be clearly marked with a confidential or proprietary legend. Information conveyed orally by the Discloser to Recipient shall be designated as proprietary and confidential at the time of such oral conveyance, shall be reduced to writing by

the Discloser within forty-five (45) days thereafter, and shall be clearly marked with a confidential or proprietary legend.

- 10.2 **Use and Protection of Information.** Recipient agrees to protect such Information of the Discloser provided to Recipient from whatever source from distribution, disclosure or dissemination to anyone except employees of Recipient with a need to know such Information solely in conjunction with Recipient's analysis of the Information and for no other purpose except as authorized herein or as otherwise authorized in writing by the Discloser. Recipient will not make any copies of the Information inspected by it.
- 10.3 **Exceptions.** Recipient will not have an obligation to protect any portion of the Information which:
- 10.3.1 (a) is made publicly available by the Discloser or lawfully by a nonparty to this Agreement; (b) is lawfully obtained by Recipient from any source other than Discloser; (c) is previously known to Recipient without an obligation to keep it confidential; or (d) is released from the terms of this Agreement by Discloser upon written notice to Recipient.
- 10.4 Recipient agrees to use the Information solely for the purposes of negotiations pursuant to 47 U.S.C. 251 or in performing its obligations under this Agreement and for no other entity or purpose, except as may be otherwise agreed to in writing by the Parties. Nothing herein shall prohibit Recipient from providing information requested by the Federal Communications Commission or a state regulatory agency with jurisdiction over this matter, or to support a request for arbitration or an allegation of failure to negotiate in good faith.
- 10.5 Recipient agrees not to publish or use the Information for any advertising, sales promotions, press releases, or publicity matters that refer either directly or indirectly to the Information or to the Discloser or any of its affiliated companies.
- 10.6 The disclosure of Information neither grants nor implies any license to the Recipient under any trademark, patent, copyright, or application which is now or may hereafter be owned by the Discloser.
- 10.7 **Survival of Confidentiality Obligations.** The Parties' rights and obligations under this Section 10 shall survive and continue in effect until two (2) years after the expiration or termination date of this Agreement with regard to all Information exchanged during the term of this Agreement. Thereafter, the Parties' rights and obligations hereunder survive and continue in effect with respect to any Information that is a trade secret under applicable law.
- 10.8 **Assignments**
- 10.9 Any assignment by either Party to any non-affiliated entity of any right, obligation or duty, or of any other interest hereunder, in whole or in part, without the prior written consent of the other Party shall be void. A Party may assign this

Agreement or any right, obligation, duty or other interest hereunder to an Affiliate of the Party without the consent of the other Party; provided, however, that the assigning Party shall notify the other Party in writing of such assignment thirty (30) days prior to the Effective Date thereof and, provided further, if the assignee is an assignee of Heritage, the assignee must provide evidence of Commission CLEC certification. The Parties shall amend this Agreement to reflect such assignments and shall work cooperatively to implement any changes required due to such assignment. All obligations and duties of any Party under this Agreement shall be binding on all successors in interest and assigns of such Party. No assignment or delegation hereof shall relieve the assignor of its obligations under this Agreement in the event that the assignee fails to perform such obligations.

11. Resolution of Disputes

- 11.1 Except as otherwise stated in this Agreement, if any dispute arises as to the interpretation of any provision of this Agreement or as to the proper implementation of this Agreement, the aggrieved Party shall petition the Commission for a resolution of the dispute. However, each Party reserves any rights it may have to seek judicial review of any ruling made by the Commission concerning this Agreement.

12. Taxes

- 12.1 Definition. For purposes of this Section, the terms “taxes” and “fees” shall include but not limited to federal, state or local sales, use, excise, gross receipts or other taxes or tax-like fees of whatever nature and however designated (including tariff surcharges and any fees, charges or other payments, contractual or otherwise, for the use of public streets or rights of way, whether designated as franchise fees or otherwise) imposed, or sought to be imposed, on or with respect to the services furnished hereunder or measured by the charges or payments therefore, excluding any taxes levied on income.

12.2 Taxes and Fees Imposed Directly On Either Providing Party or Purchasing Party.

- 12.2.1 Taxes and fees imposed on the providing Party, which are not permitted or required to be passed on by the providing Party to its customer, shall be borne and paid by the providing Party.

- 12.2.2 Taxes and fees imposed on the purchasing Party, which are not required to be collected and/or remitted by the providing Party, shall be borne and paid by the purchasing Party.

12.3 Taxes and Fees Imposed on Purchasing Party But Collected And Remitted By Providing Party.

- 12.3.1 Taxes and fees imposed on the purchasing Party shall be borne by the purchasing Party, even if the obligation to collect and/or remit such taxes or fees is placed on the providing Party.
- 12.3.2 To the extent permitted by applicable law, any such taxes and/or fees shall be shown as separate items on applicable billing documents between the Parties. Notwithstanding the foregoing, the purchasing Party shall remain liable for any such taxes and fees regardless of whether they are actually billed by the providing Party at the time that the respective service is billed.
- 12.3.3 If the purchasing Party determines that in its opinion any such taxes or fees are not payable, the providing Party shall not bill such taxes or fees to the purchasing Party if the purchasing Party provides written certification, reasonably satisfactory to the providing Party, stating that it is exempt or otherwise not subject to the tax or fee, setting forth the basis therefor, and satisfying any other requirements under applicable law. If any authority seeks to collect any such tax or fee that the purchasing Party has determined and certified not to be payable, or any such tax or fee that was not billed by the providing Party, the purchasing Party may contest the same in good faith, at its own expense. In any such contest, the purchasing Party shall promptly furnish the providing Party with copies of all filings in any proceeding, protest, or legal challenge, all rulings issued in connection therewith, and all correspondence between the purchasing Party and the taxing authority.
- 12.3.4 In the event that all or any portion of an amount sought to be collected must be paid in order to contest the imposition of any such tax or fee, or to avoid the existence of a lien on the assets of the providing Party during the pendency of such contest, the purchasing Party shall be responsible for such payment and shall be entitled to the benefit of any refund or recovery.
- 12.3.5 If it is ultimately determined that any additional amount of such a tax or fee is due to the imposing authority, the purchasing Party shall pay such additional amount, including any interest and penalties thereon.
- 12.3.6 Notwithstanding any provision to the contrary, the purchasing Party shall protect, indemnify and hold harmless (and defend at the purchasing Party's expense) the providing Party from and against any such tax or fee, interest or penalties thereon, or other charges or payable expenses (including reasonable attorney fees) with respect thereto, which are incurred by the providing Party in connection with any claim for or contest of any such tax or fee.
- 12.3.7 Each Party shall notify the other Party in writing of any assessment, proposed assessment or other claim for any additional amount of such a tax or fee by a taxing authority; such notice to be provided, if possible, at least ten (10) days prior to the date by which a response, protest or other appeal must be filed, but in no event later than thirty (30) days after receipt of such assessment, proposed assessment or claim.

- 12.4 Taxes and Fees Imposed on Providing Party But Passed On To Purchasing Party.
- 12.4.1 Taxes and fees imposed on the providing Party, which are permitted or required to be passed on by the providing Party to its customer, shall be borne by the purchasing Party.
- 12.4.2 To the extent permitted by applicable law, any such taxes and/or fees shall be shown as separate items on applicable billing documents between the Parties. Notwithstanding the foregoing, the purchasing Party shall remain liable for any such taxes and fees regardless of whether they are actually billed by the providing Party at the time that the respective service is billed.
- 12.4.3 If the purchasing Party disagrees with the providing Party's determination as to the application or basis for any such tax or fee, the Parties shall consult with respect to the imposition and billing of such tax or fee. Notwithstanding the foregoing, the providing Party shall retain ultimate responsibility for determining whether and to what extent any such taxes or fees are applicable, and the purchasing Party shall abide by such determination and pay such taxes or fees to the providing Party. The providing Party shall further retain ultimate responsibility for determining whether and how to contest the imposition of such taxes and fees; provided, however, that any such contest undertaken at the request of the purchasing Party shall be at the purchasing Party's expense.
- 12.4.4 In the event that all or any portion of an amount sought to be collected must be paid in order to contest the imposition of any such tax or fee, or to avoid the existence of a lien on the assets of the providing Party during the pendency of such contest, the purchasing Party shall be responsible for such payment and shall be entitled to the benefit of any refund or recovery.
- 12.4.5 If it is ultimately determined that any additional amount of such a tax or fee is due to the imposing authority, the purchasing Party shall pay such additional amount, including any interest and penalties thereon.
- 12.4.6 Notwithstanding any provision to the contrary, the purchasing Party shall protect indemnify and hold harmless (and defend at the purchasing Party's expense) the providing Party from and against any such tax or fee, interest or penalties thereon, or other reasonable charges or payable expenses (including reasonable attorney fees) with respect thereto, which are incurred by the providing Party in connection with any claim for or contest of any such tax or fee.
- 12.4.7 Each Party shall notify the other Party in writing of any assessment, proposed assessment or other claim for any additional amount of such a tax or fee by a taxing authority; such notice to be provided, if possible, at least ten (10) days prior to the date by which a response, protest or other appeal must be filed, but in no event later than thirty (30) days after receipt of such assessment, proposed assessment or claim.

12.5 **Mutual Cooperation.** In any contest of a tax or fee by one Party, the other Party shall cooperate fully by providing records, testimony and such additional information or assistance as may reasonably be necessary to pursue the contest. Further, the other Party shall be reimbursed for any reasonable and necessary out-of-pocket copying and travel expenses incurred in assisting in such contest.

13. **Force Majeure**

13.1 In the event performance of this Agreement, or any obligation hereunder, is either directly or indirectly prevented, restricted, or interfered with by reason of fire, flood, earthquake or like acts of God, wars, revolution, civil commotion, explosion, acts of public enemy, embargo, acts of the government in its sovereign capacity, labor difficulties, including without limitation, strikes, slowdowns, picketing, or boycotts, unavailability of equipment from vendor, changes requested by Customer, or any other circumstances beyond the reasonable control and without the fault or negligence of the Party affected, the Party affected, upon giving prompt notice to the other Party, shall be excused from such performance on a day-to-day basis to the extent of such prevention, restriction, or interference (and the other Party shall likewise be excused from performance of its obligations on a day-to-day basis until the delay, restriction or interference has ceased); provided however, that the Party so affected shall use diligent efforts to avoid or remove such causes of non-performance and both Parties shall proceed whenever such causes are removed or cease.

14. **Adoption of Agreements**

14.1 BellSouth shall make available, pursuant to 47 USC § 252 and the FCC rules and regulations regarding such availability, to Heritage any interconnection, service, or network element provided under any other agreement filed and approved pursuant to 47 USC § 252, provided a minimum of six months remains on the term of such Agreement. The Parties shall adopt all rates, terms and conditions concerning such other interconnection, service or network element and any other rates, terms and conditions that are legitimately related to or were negotiated in exchange for or in conjunction with the interconnection, service or network element being adopted. The adopted interconnection, service, or network element and agreement shall apply to the same states as such other agreement. The term of the adopted agreement or provisions shall expire on the same date as set forth in the agreement which was adopted.

15. **Modification of Agreement**

15.1 If Heritage changes its name or makes changes to its company structure or identity due to a merger, acquisition, transfer or any other reason, it is the responsibility of Heritage to notify BellSouth of said change and request that an amendment to this Agreement, if necessary, be executed to reflect said change.

- 15.2 No modification, amendment, supplement to, or waiver of the Agreement or any of its provisions shall be effective and binding upon the Parties unless it is made in writing and duly signed by the Parties.
- 15.3 In the event that any effective legislative, regulatory, judicial or other legal action materially affects any material terms of this Agreement, or the ability of Heritage or BellSouth to perform any material terms of this Agreement, Heritage or BellSouth may, on thirty (30) days' written notice require that such terms be renegotiated, and the Parties shall renegotiate in good faith such mutually acceptable new terms as may be required. In the event that such new terms are not renegotiated within ninety (90) days after such notice, the Dispute shall be referred to the Dispute Resolution procedure set forth in this Agreement.
- 15.4 Notwithstanding anything to the contrary in this Agreement, this Agreement shall not be amended or modified after the expiration date hereof as set forth in Section 2 above.
- 16. Non-waiver of Legal Rights**
- 16.1 Execution of this Agreement by either Party does not confirm or infer that the executing Party agrees with any decision(s) issued pursuant to the Telecommunications Act of 1996 and the consequences of those decisions on specific language in this Agreement. Neither Party waives its rights to appeal or otherwise challenge any such decision(s) and each Party reserves all of its rights to pursue any and all legal and/or equitable remedies, including appeals of any such decision(s).
- 17. Severability**
- 17.1 If any provision of this Agreement, or the application of such provision to either Party or circumstance, shall be held invalid, the remainder of the Agreement, or the application of any such provision to the Parties or circumstances other than those to which it is held invalid, shall not be affected thereby, provided that the Parties shall attempt to reformulate such invalid provision to give effect to such portions thereof as may be valid without defeating the intent of such provision.
- 18. Waivers**
- 18.1 A failure or delay of either Party to enforce any of the provisions hereof, to exercise any option which is herein provided, or to require performance of any of the provisions hereof shall in no way be construed to be a waiver of such provisions or options, and each Party, notwithstanding such failure, shall have the right thereafter to insist upon the performance of any and all of the provisions of this Agreement.
- 19. Governing Law**

19.1 This Agreement shall be governed by, and construed and enforced in accordance with, the laws of the State of Georgia, without regard to its conflict of laws principles.

20. Arm's Length Negotiations

20.1 This Agreement was executed after arm's length negotiations between the undersigned Parties and reflects the conclusion of the undersigned that this Agreement is in the best interests of all Parties.

21. Notices

21.1 Every notice, consent, approval, or other communications required or contemplated by this Agreement shall be in writing and shall be delivered by hand, by overnight courier or by US mail postage prepaid, address to:

BellSouth Telecommunications, Inc.

Account Team
600 North 19th Street
Birmingham, Alabama 35203

and

General Attorney - COU
Suite 4300
675 W. Peachtree St.
Atlanta, GA 30375

Heritage Technologies, Ltd.

2500A Central Parkway
Houston, Texas 77092

or at such other address as the intended recipient previously shall have designated by written notice to the other Party.

21.2 Unless otherwise provided in this Agreement, notice by mail shall be effective on the date it is officially recorded as delivered by return receipt or equivalent, and in the absence of such record of delivery, it shall be presumed to have been delivered the fifth day, or next business day after the fifth day, after it was deposited in the mails.

21.3 Notwithstanding the foregoing, BellSouth may provide Heritage notice via Internet posting of price changes, changes to the terms and conditions of services available for resale per Commission Orders. BellSouth will also post changes to business

processes and policies, notices of new service offerings, and changes to service offerings not requiring an amendment to this Agreement, notices required to be posted to BellSouth's website, and any other information of general applicability to CLECs.

22. Rule of Construction

22.1 No rule of construction requiring interpretation against the drafting Party hereof shall apply in the interpretation of this Agreement.

23. Headings of No Force or Effect

23.1 The headings of Articles and Sections of this Agreement are for convenience of reference only, and shall in no way define, modify or restrict the meaning or interpretation of the terms or provisions of this Agreement.

24. Multiple Counterparts

24.1 This Agreement may be executed in multiple counterparts, each of which shall be deemed an original, but all of which shall together constitute but one and the same document.

25. Implementation of Agreement

25.1 If Heritage is a facilities based provider or a facilities based and resale provider, this section shall apply. Within 60 days of the execution of this Agreement, the Parties may adopt a schedule for the implementation of the Agreement. The schedule shall state with specificity time frames for submission of including but not limited to, network design, interconnection points, collocation arrangement requests, pre-sales testing and full operational time frames for the business and residential markets. An implementation template which may be used for the implementation schedule is contained in Attachment 10 of this Agreement.

26. Filing of Agreement

26.1 Upon execution of this Agreement it shall be filed with the appropriate state regulatory agency pursuant to the requirements of Section 252 of the Act, and the Parties shall share equally any filing fees therefor. If the regulatory agency imposes any filing or public interest notice fees regarding the filing or approval of the Agreement, Heritage shall be responsible for publishing the required notice and the publication and/or notice costs shall be borne by Heritage. Notwithstanding the foregoing, this Agreement shall not be submitted for approval by the appropriate state regulatory agency unless and until such time as Heritage is duly certified as a local exchange carrier in such state, except as otherwise required by a state Commission.

27. Compliance with Applicable Law

27.1 Each Party shall comply at its own expense with Applicable Law.

28. Necessary Approvals

28.1 Each Party shall be responsible for obtaining and keeping in effect all approvals from, and rights granted by, governmental authorities, building and property owners, other carriers, and any other persons that may be required in connection with the performance of its obligations under this Agreement. Each Party shall reasonably cooperate with the other Party in obtaining and maintaining any required approvals and rights for which such Party is responsible.

29. Good Faith Performance

29.1 Each Party shall act in good faith in its performance under this Agreement and, in each case in which a Party's consent or agreement is required or requested hereunder, such Party shall not unreasonably withhold or delay such consent or agreement.

30. Nonexclusive Dealings

30.1 This Agreement does not prevent either Party from providing or purchasing services to or from any other person nor, except as provided in Section 252(i) of the Act, does it obligate either Party to provide or purchase any services (except insofar as the Parties are obligated to provide access to Interconnection, services and Network Elements to Heritage as a requesting carrier under the Act).

31. Rate True-Up

31.1 This section applies to Local Interconnection and/or Unbundled Network Elements and Other Services rates that are interim or expressly subject to true-up under this Agreement.

31.2 The interim prices for Network Elements and Other Services and Local Interconnection shall be subject to true-up according to the following procedures:

31.3 The interim prices shall be true-up, either up or down, based on final prices determined either by further agreement between the Parties, or by a final order (including any appeals) of the Commission which final order meets the criteria of (3) below. The Parties shall implement the true-up by comparing the actual volumes and demand for each item, together with interim prices for each item, with the final prices determined for each item. Each Party shall keep its own records upon which the true-up can be based, and any final payment from one Party to the other shall be in an amount agreed upon by the Parties based on such records. In the event of any disagreement as between the records or the Parties regarding the amount of such true-up, the Parties agree that the body having jurisdiction over the matter shall be called upon to resolve such differences, or the Parties may mutually agree to submit the matter to the Dispute Resolution process in accordance with

the provisions of Section 11 of the General Terms and Conditions and Attachment 1 of this Agreement.

- 31.4 The Parties may continue to negotiate toward final prices, but in the event that no such Agreement is reached within nine (9) months, either Party may petition the Commission to resolve such disputes and to determine final prices for each item. Alternatively, upon mutual agreement, the Parties may submit the matter to the Dispute Resolution Process set forth in Section 11 of the General Terms and Conditions and Attachment 1 of this Agreement, so long as they file the resulting Agreement with the Commission as a “negotiated Agreement” under Section 252(e) of the Act.
- 31.5 An effective order of the Commission that forms the basis of a true-up shall be based upon cost studies submitted by either or both Parties to the Commission and shall be binding upon BellSouth and Heritage specifically or upon all carriers generally, such as a generic cost proceeding.
- 32. Survival**
- 32.1 The Parties’ obligations under this Agreement which by their nature are intended to continue beyond the termination or expiration of this Agreement shall survive the termination or expiration of this Agreement.
- 33. Establishment of Service**
- If BellSouth is informed that an unauthorized change in local service to Heritage has occurred, BellSouth will reestablish service with the appropriate local service provider and will assess Heritage as the CLEC initiating the alleged unauthorized change, the appropriate nonrecurring charges, as set forth in Section A4 of the General Subscriber Service Tariff. In accordance with FCC Slamming Liability Rules, the relevant governmental agency will determine if an unauthorized change has occurred. Resolution of all relevant issues shall be handled directly with the authorized CLEC and Heritage.
- 34. Entire Agreement**
- 34.1 This Agreement and its Attachments, incorporated herein by this reference, sets forth the entire understanding and supersedes prior Agreements between the Parties relating to the subject matter contained herein and merges all prior discussions between them. Any orders placed under prior agreements between the Parties shall be governed by the terms of this Agreement. Neither Party shall be bound by any definition, condition, provision, representation, warranty, covenant or promise other than as expressly stated in this Agreement or as is contemporaneously or subsequently set forth in writing and executed by a duly authorized officer or representative of the Party to be bound hereby.

34.2 **This Agreement may include attachments with provisions for the following services:**

Network Elements and Other Services
Local Interconnection
Resale
Collocation

34.3 **The following services are included as options for purchase by Heritage. Heritage may elect to purchase said services by written request to its Account Manager if applicable:**

Optional Daily Usage File (ODUF)
Enhanced Optional Daily Usage File (EODUF)
Access Daily Usage File (ADUF)
Line Information Database (LIDB) Storage
Centralized Message Distribution Service (CMDS)
Calling Name (CNAM)
LNP Data Base Query Service

IN WITNESS WHEREOF, the Parties have executed this Agreement the day and year written below.

BellSouth Telecommunications, Inc.

Heritage Technologies, Ltd.

By: Greg Follenber

By: Helen S. Morgan

Name: Greg Follenber

Name: Helen Morgan

Title: Senior Director

Title: Vice President - Regulatory

Date: 12/3/01

Date: 11/27/2001

Attachment 1

Resale

Table of Contents

1. Discount Rates	3
2. Definition of Terms.....	3
3. General Provisions.....	3
4. BellSouth's Provision of Services to Heritage	8
5. Maintenance of Services.....	9
6. Establishment of Service	10
7. Payment And Billing Arrangements	11
8. Discontinuance of Service.....	14
9. Line Information Database (LIDB).....	16
10. RAO Hosting	16
11. Optional Daily Usage File (ODUF)	16
12. Enhanced Optional Daily Usage File (EODUF).....	16
Resale Restrictions	Exhibit A
Line Information Database (LIDB) Storage Agreement	Exhibit B
Optional Daily Usage File (ODUF)	Exhibit C
Enhanced Option Daily Usage File (EODUF)	Exhibit D
Resale Discounts and Rates	Exhibit E

RESALE

1. Discount Rates

- 1.1 The discount rates applied to Heritage purchases of BellSouth Telecommunications Services for the purpose of resale shall be as set forth in Exhibit E. Such discounts have been determined by the applicable Commission to reflect the costs avoided by BellSouth when selling a service for wholesale purposes.
- 1.2 The telecommunications services available for purchase by Heritage for the purposes of resale to Heritage's End Users shall be available at BellSouth's tariffed rates less the discount set forth in Exhibit E to this Agreement and subject to the exclusions and limitations set forth in Exhibit A to this Agreement.

2. Definition of Terms

- 2.1 COMPETITIVE LOCAL EXCHANGE COMPANY (CLEC) means a telephone company certificated by the Commission to provide local exchange service within BellSouth's franchised area.
- 2.2 CUSTOMER OF RECORD means the entity responsible for placing application for service; requesting additions, rearrangements, maintenance or discontinuance of service; payment in full of charges incurred such as non-recurring, monthly recurring, toll, directory assistance, etc.
- 2.3 DEPOSIT means assurance provided by a customer in the form of cash, surety bond or bank letter of credit to be held by BellSouth.
- 2.4 END USER means the ultimate user of the Telecommunications Service.
- 2.5 END USER CUSTOMER LOCATION means the physical location of the premises where an End User makes use of the telecommunications services.
- 2.6 NEW SERVICES means functions, features or capabilities that are not currently offered by BellSouth. This includes packaging of existing services or combining a new function, feature or capability with an existing service.
- 2.7 RESALE means an activity wherein a certificated CLEC, such as Heritage, subscribes to the telecommunications services of BellSouth and then offers those telecommunications services to the public.

3. General Provisions

- 3.1 All of the negotiated rates, terms and conditions set forth in this Attachment pertain to the resale of BellSouth's retail telecommunications services and other

services specified in this Attachment. Subject to effective and applicable FCC and Commission rules and orders, BellSouth shall make available to Heritage for resale those telecommunications services BellSouth makes available, pursuant to its General Subscriber Services Tariff and Private Line Services Tariff, to customer who are not telecommunications carriers.

- 3.1.1 When Heritage provides Resale service in a cross boundary area (areas that are part of the local serving area of another state's exchange) the rates, regulations and discounts for the tariffing state will apply. Billing will be from the serving state.
- 3.1.2 In Tennessee, if Heritage provides its own operator services and directory services, the discount shall be 21.56%. Heritage must provide written notification to BellSouth within 30 days prior to providing its own operator services and directory services to qualify for the higher discount rate of 21.56%.
- 3.2 Heritage may purchase resale services from BellSouth for their own use in operating their business. The resale discount will apply to those services under the following conditions:
 - 3.2.1 Heritage must resell services to other End Users.
 - 3.2.2 Heritage must order services through resale interfaces, i.e., the Local Carrier Service Center (LCSC) and/or appropriate Resale Account Teams pursuant this Agreement.
 - 3.2.3 Heritage cannot be a competitive local exchange telecommunications company for the single purpose of selling to themselves.
- 3.3 Heritage will be the customer of record for all services purchased from BellSouth. Except as specified herein, BellSouth will take orders from, bill and receive payment from Heritage for said services.
- 3.4 Heritage will be BellSouth's single point of contact for all services purchased pursuant to this Agreement. BellSouth shall have no contact with the End User except to the extent provided for herein. Each Party shall provide to the other a nation wide (50 states) toll-free contact number for purposes of repair and maintenance.
- 3.5 BellSouth will continue to bill the End User for any services that the End User specifies it wishes to receive directly from BellSouth. BellSouth maintains the right to serve directly any End User within the service area of Heritage. BellSouth will continue to market directly its own telecommunications products and services and in doing so may establish independent relationships with End Users of Heritage. Neither Party shall interfere with the right of any person or entity to obtain service directly from the other Party.

- 3.5.1 When a subscriber of Heritage or BellSouth elects to change his/her carrier to the other Party, both Parties agree to release the subscriber's service to the other Party concurrent with the due date of the service order, which shall be established based on the standard interval for the subscriber's requested service as set forth in BellSouth Product and Services Interval Guide.
- 3.5.2 BellSouth and Heritage will refrain from contacting subscribers who have placed or whose selected carrier has placed on their behalf an order to change his/her service provider from BellSouth or Heritage to the other Party until such time that the order for service has been completed.
- 3.6 Current telephone numbers may normally be retained by the End User and are assigned to the service furnished. However, neither Party nor the End User has a property right to the telephone number or any other call number designation associated with services furnished by BellSouth, and no right to the continuance of service through any particular central office. BellSouth reserves the right to change such numbers, or the central office designation associated with such numbers, or both, whenever BellSouth deems it necessary to do so in the conduct of its business and in accordance with BellSouth practices and procedures on a nondiscriminatory basis.
- 3.7 For the purpose of the resale of BellSouth's telecommunications services by Heritage, BellSouth will provide Heritage with on line access to telephone numbers on a first come first served basis. Heritage acknowledges that there may be instances where there is a shortage of telephone numbers in a particular Common Language Location Identifier Code (CLLIC); and in such instances, Heritage shall return numbers to BellSouth upon BellSouth's request. BellSouth shall make all such requests on a nondiscriminatory basis.
- 3.8 Further, upon Heritage's request, and for the purpose of the resale of BellSouth's telecommunications services by Heritage, BellSouth will reserve up to 100 telephone numbers per CLLIC, for Heritage's sole use. Assignment, reservation and use of telephone numbers shall be governed by applicable FCC rules and regulations.
- 3.9 Service is furnished subject to the condition that it will not be used for any unlawful purpose.
- 3.10 Service will be discontinued if any law enforcement agency advises that the service being used is in violation of the law.
- 3.11 BellSouth can refuse service when it has grounds to believe that service will be used in violation of the law.

- 3.12 BellSouth will cooperate with law enforcement agencies with subpoenas and court orders relating to Heritage's End Users, pursuant to Section 7 of the General Terms and Conditions.
- 3.13 If Heritage or its End Users utilize a BellSouth resold telecommunications service in a manner other than that for which the service was originally intended as described in BellSouth's retail tariffs, Heritage has the responsibility to notify BellSouth. BellSouth will only provision and maintain said service consistent with the terms and conditions of the tariff describing said service.
- 3.14 Facilities and/or equipment utilized by BellSouth to provide service to Heritage remain the property of BellSouth.
- 3.15 White page directory listings for Heritage End Users will be provided in accordance with Section 5 of the General Terms and Conditions.
- 3.16 BellSouth provides electronic access to customer record information. Access is provided through the Local Exchange Navigation System (LENS) and the Telecommunications Access Gateway (TAG). Customer Record Information includes but is not limited to, customer specific information in CRIS and RSAG. In addition, Heritage shall provide to BellSouth access to customer record information including electronic access where available. Otherwise, upon request by BellSouth Heritage shall provide paper copies of customer record information within a reasonable period of time. Customer Record Information is equivalent to but not limited to the type of customer specific information contained in CRIS and RSAG. The Parties agree not to view, copy, or otherwise obtain access to the customer record information of any customer without that customer's permission, and further agrees that Heritage and BellSouth will obtain access to customer record information only in strict compliance with applicable laws, rules, or regulations of the State in which the service is provided.
- 3.17 Operational Support Systems (OSS)
- 3.17.1 BellSouth has developed and made available the following mechanized systems by which Heritage may submit LSRs electronically: Local Exchange Navigation System (LENS), Electronic Data Interchange (EDI) and Telecommunications Access Gateway (TAG). All costs incurred by BellSouth to develop and implement operational interfaces shall be recovered from CLECs who utilize the interfaces.
- 3.17.2 LSRs submitted by means of one of these interactive interfaces will incur an OSS electronic charge as set forth in Exhibit E to this Agreement. An individual LSR will be identified for billing purposes by its Purchase Order Number (PON). LSRs submitted by means other than one of these interactive interfaces (Mail, fax, courier, etc.) will incur a a manual order charge as set forth in Exhibit E to this

Agreement. Supplements or clarifications to a previously billed LSR will not incur another OSS charge.

- 3.17.3 Denial/Restoral OSS Charge. In the event Heritage provides a list of customers to be denied and restored, rather than an LSR, each location on the list will require a separate PON and therefore will be billed as one LSR per location.
- 3.17.4 Cancellation OSS Charge. Heritage will incur an OSS charge for an accepted LSR that is later canceled.
- 3.17.5 Threshold Billing Plan. Heritage will incur the mechanized rate for all LSRs, both mechanized and manual, if the percentage of mechanized LSRs to total LSRs meets or exceeds the threshold percentage of 90% in the year 2001. The threshold plan will be discontinued in 2002.
- 3.17.5.1 BellSouth will track the total LSR volume for each CLEC for each quarter. At the end of that time period, a Percent Electronic LSR calculation will be made for that quarter based on the LSR data tracked in the LCSC. If this percentage exceeds the threshold volume, all of that CLEC's future manual LSRs for the following quarter will be billed at the mechanized LSR rate. To allow time for obtaining and analyzing the data and updating the billing system, this billing change will take place on the first day of the second month following the end of the quarter (e.g. May 1 for 1Q, Aug 1 for 2Q, etc.). There will be no adjustments to the amount billed for previously billed LSRs.
- 3.18 Where available to BellSouth's End Users, BellSouth shall provide the following telecommunications services at a discount to allow for voice mail services:
- Message Waiting Indicator ("MWI"), stutter dialtone and message waiting light feature capabilities
 - Call Forward Busy Line ("CF/B")
 - Call Forward Don't Answer ("CF/DA")
- Further, BellSouth messaging services set forth in BellSouth's Messaging Service Information Package shall be made available for resale without the wholesale discount.
- 3.19 BellSouth shall provide branding for, or shall unbrand, voice mail services for Heritage per the Bona Fide Request/New Business Request process as set forth in Section 6 of the General Terms and Conditions.
- 3.20 BellSouth's Inside Wire Maintenance Service Plan is available for resale at rates, terms and conditions as set forth by BellSouth and without the wholesale discount.

- 3.21 In the event Heritage acquires an end user whose service is provided pursuant to a BellSouth Special Assembly, BellSouth shall make available to Heritage that Special Assembly at the wholesale discount at Heritage's option. Heritage shall be responsible for all terms and conditions of such Special Assembly including but not limited to termination liability if applicable.
- 3.22 BellSouth shall provide 911/E911 for Heritage customers in the same manner that it is provided to BellSouth customers. BellSouth shall provide and validate Heritage customer information to the PSAP. BellSouth shall use its service order process to update and maintain, on the same schedule that it uses for its customers, the Heritage customer service information in the ALI/DMS (Automatic Location Identification/Location Information) databases used to support 911/E911 services.
- 3.23 BellSouth shall bill, and Heritage shall pay, the End User line charge associated with implementing Number Portability as set forth in BellSouth's FCC No. 1 tariff. This charge is not subject to the wholesale discount.
- 3.24 Pursuant to 47 CFR Section 51.617, BellSouth will bill to Heritage, and Heritage shall pay, End User common line charges identical to the End User common line charges BellSouth bills its End Users.
- 3.25 BellSouth shall provide pre-ordering, ordering and provisioning and maintenance and repair services to Heritage that are equivalent to the pre-ordering, ordering and provisioning and maintenance and repair services BellSouth provides to itself or any other CLEC, where technically feasible. The guidelines for pre-ordering, ordering and provisioning and maintenance and repair are set forth in the various guides and business rules, as appropriate, and as they are amended from time to time during this Agreement. The guides and business rules may be referenced at the following site:
- <http://www.interconnection.bellsouth.com>
- 3.26 Upon a particular Commission's issuance of an Order pertaining to Performance Measurements in a proceeding expressly applicable to all CLECs generally, BellSouth shall implement in that state such Performance Measurements as of the date specified by the Commission.
- 4. BellSouth's Provision of Services to Heritage**
- 4.1 Resale of BellSouth services shall be as follows:
- 4.1.1 The resale of telecommunications services shall be limited to users and uses conforming to the class of service restrictions.
- 4.1.2 Hotel and Hospital PBX services are the only telecommunications services available for resale to Hotel/Motel and Hospital End Users, respectively. Similarly, Access Line Service for Customer Provided Coin Telephones is the only

local service available for resale to Payphone Service Provider (PSP) customers. Shared Tenant Service customers can only be sold those local exchange access services available in BellSouth's A23 Shared Tenant Service Tariff in the states of Florida, Georgia, North Carolina and South Carolina, and in A27 in the states of Alabama, Kentucky, Louisiana, Mississippi and Tennessee.

- 4.1.3 BellSouth reserves the right to periodically audit services purchased by Heritage to establish authenticity of use. Such audit shall not occur more than once in a calendar year. Heritage shall make any and all records and data available to BellSouth or BellSouth's auditors on a reasonable basis. BellSouth shall bear the cost of said audit. Any information provided by Heritage for purposes of such audit shall be deemed Confidential Information pursuant to the General Terms and Conditions of this Agreement.
- 4.2 Subject to Exhibit A hereto, resold services can only be used in the same manner as specified in BellSouth's Tariffs. Resold services are subject to the same terms and conditions as are specified for such services when furnished to an individual End User of BellSouth in the appropriate section of BellSouth's Tariffs. Specific tariff features (e.g. a usage allowance per month) shall not be aggregated across multiple resold services.
- 4.3 Heritage may resell services only within the specific service area as defined in its certificate of operation approved by the Commission.
- 4.4 If Heritage cancels an order for resold services, any costs incurred by BellSouth in conjunction with provisioning of such order will be recovered in accordance with BellSouth's General Subscriber Services Tariffs and Private Line Services Tariffs.
- 5. Maintenance of Services**
- 5.1 Heritage will adopt and adhere to the standards contained in the applicable BellSouth Operational Understanding regarding maintenance of service. The BellSouth Operational Understanding can be accessed via the internet @ <http://www.interconnection.bellsouth.com>.
- 5.2 Services resold pursuant to this Attachment and BellSouth's General Subscriber Service Tariff and Private Line Service Tariff and facilities and equipment provided by BellSouth shall be maintained by BellSouth.
- 5.3 Heritage or its End Users may not rearrange, move, disconnect, remove or attempt to repair any facilities owned by BellSouth except with the written consent of BellSouth.
- 5.4 Heritage accepts responsibility to notify BellSouth of situations that arise that may result in a service problem.

- 5.5 Heritage will contact the appropriate repair centers in accordance with procedures established by BellSouth.
- 5.6 For all repair requests, Heritage shall adhere to BellSouth's prescreening guidelines prior to referring the trouble to BellSouth.
- 5.7 BellSouth will bill Heritage for handling troubles that are found not to be in BellSouth's network pursuant to its standard time and material charges. The standard time and material charges will be no more than what BellSouth charges to its retail customers for the same services.
- 5.8 BellSouth reserves the right to contact Heritage's End Users, if deemed necessary, for maintenance purposes.
- 6. Establishment of Service**
- 6.1 After receiving certification as a local exchange company from the appropriate regulatory agency, Heritage will provide the appropriate BellSouth service center the necessary documentation to enable BellSouth to establish a master account for Heritage's resold services. Such documentation shall include the Application for Master Account, proof of authority to provide telecommunications services, an Operating Company Number ("OCN") assigned by the National Exchange Carriers Association ("NECA") and a tax exemption certificate, if applicable. When necessary deposit requirements are met, as described in Section 6.2 below, BellSouth will begin taking orders for the resale of service.
- 6.1.2 Service orders will be in a standard format designated by BellSouth.
- 6.1.3 Heritage shall provide to BellSouth a blanket letter of authorization ("LOA") certifying that Heritage will have End User authorization prior to viewing the End User's customer service record or switching the End User's service. BellSouth will not require End User confirmation prior to establishing service for Heritage's End User customer. Heritage must, however, be able to demonstrate End User authorization upon request.
- 6.1.4 BellSouth will accept a request directly from the End User for conversion of the End User's service from Heritage to BellSouth or will accept a request from another CLEC for conversion of the End User's service from Heritage to such other CLEC. Upon completion of the conversion BellSouth will notify Heritage that such conversion has been completed.
- 6.2 Deposit Policy. When purchasing services from BellSouth, Heritage will be required to complete the BellSouth Credit Profile and provide information regarding credit worthiness. Based on the results of the credit analysis, BellSouth reserves the right to secure the account with a suitable form of security deposit.

- 6.2.1 Such security deposit shall take the form of cash, an Irrevocable Letter of Credit (BellSouth form), Surety Bond (BellSouth form) or, in sole discretion, some other form of security.
- 6.2.2 Such security deposit shall be required prior to the inauguration of service.
- 6.2.3 Security deposits collected under this Section shall not exceed two months' estimated billing.
- 6.2.4 The fact that a security deposit has been made in no way relieves Heritage from complying with BellSouth's regulations as to advance payments. Any such security deposit shall in no way release Heritage from its obligation to make complete and timely payments of its bills.
- 6.2.5 If in the sole opinion of BellSouth, circumstances so warrant and/or gross monthly billing has increased beyond the level initially used to determine the level of security, BellSouth reserves the right to request additional security and/or file a Uniform Commercial Code (UCCI) security interest in Heritage's "accounts receivables and proceeds."
- 6.2.6 In the event Heritage fails to remit to BellSouth any deposit requested pursuant to this Section, service to Heritage may be terminated in accordance with the terms of Section 8.2 of this Attachment, and any security deposits will be applied to Heritage's account(s).
- 6.2.7 In the event service to Heritage is terminated due to Heritage's default on its account, any security deposits held will be applied to Heritage's account.
- 6.2.8 Interest on a security deposit, if provided in cash, shall accrue and be paid in accordance with the terms in the appropriate BellSouth tariff.

7. Payment And Billing Arrangements

- 7.1 Prior to submitting orders to BellSouth for local service, a master account must be established for Heritage. Heritage is required to provide the following before a master account is established: proof of PSC/PUC certification, the Application for Master Account, an Operating Company Number ("OCN") assigned by the National Exchange Carriers Association ("NECA") and a tax exemption certificate, if applicable.
- 7.2 BellSouth shall bill Heritage on a current basis all applicable charges and credits.
- 7.3 Payment of all charges will be the responsibility of Heritage. Heritage shall make payment to BellSouth for all services billed. BellSouth is not responsible for payments not received by Heritage from Heritage's End User. BellSouth will not become involved in billing disputes that may arise between Heritage and its End

User. Payments made to BellSouth as payment on account will be credited to an accounts receivable master account and not to an End User's account.

- 7.4 BellSouth will render bills each month on established bill days for each of Heritage's accounts.
- 7.5 BellSouth will bill Heritage in advance for all services to be provided during the ensuing billing period except charges associated with service usage, which will be billed in arrears. Charges will be calculated on an individual End User account level, including, if applicable, any charge for usage or usage allowances. BellSouth will also bill Heritage, and Heritage will be responsible for and remit to BellSouth, all charges applicable to resold services including but not limited to 911 and E911 charges, End Users common line charges, federal subscriber line charges, telecommunications relay charges (TRS), and franchise fees.
- 7.6 The payment will be due by the next bill date (i.e., same date in the following month as the bill date) and is payable in immediately available funds. Payment is considered to have been made when received by BellSouth.
- 7.6.1 If the payment due date falls on a Sunday or on a Holiday which is observed on a Monday, the payment due date shall be the first non-Holiday day following such Sunday or Holiday. If the payment due date falls on a Saturday or on a Holiday which is observed on Tuesday, Wednesday, Thursday, or Friday, the payment due date shall be the last non-Holiday day preceding such Saturday or Holiday. If payment is not received by the payment due date, a late payment charge, as set forth in Section 7.8 following, shall apply.
- 7.6.2 If Heritage requests multiple billing media or additional copies of bills, BellSouth will provide these at an appropriate charge to Heritage.
- 7.6.3 Notices. Notwithstanding anything to the contrary in this Agreement, all bills and notices regarding billing matters, including notices relating to security deposits, to rejection of additional orders, from Heritage and to disconnection of services for nonpayment of charges, shall be forwarded to the individual and/or address provided by Heritage in establishment of its billing account(s) with BellSouth, or to the individual and/or address subsequently provided by Heritage as the contact for billing information. All monthly bills and notices described in this Section shall be forwarded to the same individual and/or address; provided, however, upon written notices from Heritage to BellSouth's billing organization, a final notice of disconnection of services purchased by Heritage under this Agreement shall be sent via certified mail to the individuals listed in the Notices provision of the General Terms and Conditions of this Agreement at least 30 days before BellSouth takes any action to terminate such services.
- 7.6.4 Billing Disputes

- 7.6.4.1 Each Party agrees to notify the other Party in writing upon the discovery of a billing dispute. In the event of a billing dispute, the Parties will endeavor to resolve the dispute within sixty (60) calendar days of the notification date. If the Parties are unable within the 60 day period to reach resolution, then the aggrieved Party may pursue dispute resolution in accordance with the General Terms and Conditions of this Agreement.
- 7.6.4.2 For purposes of this Section, a billing dispute means a dispute of a specific amount of money actually billed by BellSouth. The dispute must be clearly explained by the disputing Party and supported by written documentation, which clearly shows the basis for disputing charges. By way of example and not by limitation, a billing dispute will not include the refusal to pay all or part of a bill or bills when no written documentation is provided to support the dispute, nor shall a billing dispute include the refusal to pay other amounts owed by the billed Party until the dispute is resolved. Claims by the billed Party for damages of any kind will not be considered a billing dispute for purposes of this Section. Once the billing dispute is resolved, the disputing Party will make immediate payment of any of the disputed amount owed to the billing Party or the billing Party shall have the right to pursue normal treatment procedures. Any credits due to the disputing Party, pursuant to the billing dispute, will be applied to the disputing Party's account by the billing Party immediately upon resolution of the dispute.
- 7.6.4.3 If a Party disputes a charge and does not pay such charge by the payment due date, such charges shall be subject to late payment charges as set forth in the Late Payment Charges provision of this Attachment. If a Party disputes charges and the dispute is resolved in favor of such Party, the other Party shall credit the bill of the disputing Party for the amount of the disputed charges along with any late payment charges assessed no later than the second Bill Date after the resolution of the dispute. Accordingly, if a Party disputes charges and the dispute is resolved in favor of the other Party, the disputing Party shall pay the other Party the amount of the disputed charges and any associated late payment charges assessed no later than the second bill payment due date after the resolution of the dispute. BellSouth shall only assess interest on previously assessed late payment charges in a state where it has authority pursuant to its tariffs.
- 7.7 Upon proof of tax exempt certification from Heritage, the total amount billed to Heritage will not include any taxes due from the End User to reflect the tax exempt certification and local tax laws. Heritage will be solely responsible for the computation, tracking, reporting, and payment of taxes applicable to Heritage's End User.
- 7.8 If any portion of the payment is received by BellSouth after the payment due date as set forth preceding, or if any portion of the payment is received by BellSouth in funds that are not immediately available to BellSouth, then a late payment charge shall be due to BellSouth. The late payment charge shall be the portion of the payment not received by the payment due date times a late factor and will be

applied on a per bill basis. The late factor shall be as set forth in Section A2 of the General Subscriber Services Tariff or Section B2 of the Private Line Service Tariff, as applicable. Heritage will be charged a fee for all returned checks as set forth in Section to A2 of the General Subscriber Services Tariff or in applicable state law.

- 7.9 Any switched access charges associated with interexchange carrier access to the resold local exchange lines will be billed by, and due to, BellSouth.
- 7.10 BellSouth will not perform billing and collection services for Heritage as a result of the execution of this Agreement. All requests for billing services should be referred to the appropriate entity or operational group within BellSouth.
- 7.11 In general, BellSouth will not become involved in disputes between Heritage and Heritage's End User customers relating to resold services. If a dispute does arise that cannot be settled without the involvement of BellSouth, Heritage shall contact the designated Service Center for resolution. BellSouth will assist in the resolution of the dispute and will work with Heritage to resolve the matter in as timely a manner as possible. Heritage may be required to submit documentation to substantiate the claim.

8. Discontinuance of Service

- 8.1 The procedures for discontinuing service to an End User are as follows:
 - 8.1.1 BellSouth will deny service to Heritage's End User on behalf of, and at the request of, Heritage. Upon restoration of the End User's service, restoral charges will apply and will be the responsibility of Heritage.
 - 8.1.2 At the request of Heritage, BellSouth will disconnect a Heritage End User customer.
 - 8.1.3 All requests by Heritage for denial or disconnection of an End User for nonpayment must be in writing.
 - 8.1.4 Heritage will be made solely responsible for notifying the End User of the proposed disconnection of the service.
 - 8.1.5 BellSouth will continue to process calls made to the Annoyance Call Center and will advise Heritage when it is determined that annoyance calls are originated from one of its End User's locations. BellSouth shall be indemnified, defended and held harmless by Heritage and/or the End User against any claim, loss or damage arising from providing this information to Heritage. It is the responsibility of Heritage to take the corrective action necessary with its End Users who make annoying calls. (Failure to do so will result in BellSouth's disconnecting the End User's service.)

- 8.1.6 BellSouth may disconnect and reuse facilities when the facility is in a denied state and BellSouth has received an order to establish new service or transfer of service from an End User or an End User's CLEC at the same address served by the denied facility.
- 8.2 The procedures for discontinuing service to Heritage are as follows:
- 8.2.1 BellSouth reserves the right to suspend or terminate service in the event of prohibited, unlawful or improper use of the facilities or service, abuse of the facilities, or any other violation or noncompliance by Heritage of the rules and regulations of BellSouth's Tariffs.
- 8.2.2 BellSouth reserves the right to suspend or terminate service for nonpayment. If payment of amounts not subject to a billing dispute, as described in Section 7.6.4, is not received by the bill day in the month after the original bill day, BellSouth may provide written notice to Heritage, that additional applications for service such as access to the Operational Support Systems for pre-ordering, ordering and provisioning of services will be refused and that any pending orders for service will not be completed if payment is not received by the fifteenth day following the date of the notice. In addition BellSouth may, at the same time, provide written notice to the person designated by Heritage to receive notices of noncompliance that BellSouth may discontinue the provision of existing services to Heritage, if payment is not received by the thirtieth day following the date of the notice.
- 8.2.3 In the case of such discontinuance, all billed charges, as well as applicable termination charges, shall become due.
- 8.2.4 If BellSouth does not discontinue the provision of the services involved on the date specified in the thirty days notice and Heritage's noncompliance continues, nothing contained herein shall preclude BellSouth's right to discontinue the provision of the services to Heritage without further notice.
- 8.2.5 Upon discontinuance of service on a Heritage's account, service to Heritage's End Users will be denied. BellSouth will also reestablish service at the request of the End User or Heritage upon payment of the appropriate connection fee and subject to BellSouth's normal application procedures. Heritage is solely responsible for notifying the End User of the proposed disconnection of the service.
- 8.2.6 If within fifteen days after an End User's service has been denied no contact has been made in reference to restoring service, the End User's service will be disconnected.

9. Line Information Database (LIDB)

9.1 BellSouth will store in its Line Information Database (LIDB) records relating to service only in the BellSouth region. The LIDB Storage Agreement is included in this Attachment as Exhibit B.

9.2 BellSouth will provide LIDB Storage upon written request to Heritage's Account Manager stating a requested activation date.

10. RAO Hosting

10.1 RAO Hosting is not required for resale in the BellSouth region.

11. Optional Daily Usage File (ODUF)

11.1 The Optional Daily Usage File (ODUF) Agreement with terms and conditions is included in this Attachment as Exhibit C. Rates for ODUF are as set forth in Exhibit E of this Attachment.

11.2 BellSouth will provide ODUF service upon written request to its Account Manager stating a requested activation date.

12. Enhanced Optional Daily Usage File (EODUF)

12.1 The Enhanced Optional Daily Usage File (EODUF) service Agreement with terms and conditions is included in this Attachment as Exhibit D. Rates for EODUF are as set forth in Exhibit E of this Attachment.

12.2 BellSouth will provide EODUF service upon written request to its Account Manager stating a requested activation date.

EXCLUSIONS AND LIMITATIONS ON SERVICES AVAILABLE FOR RESALE (Note 5)

Type of Service	AL		FL		GA		KY		LA		MS		NC		SC		TN	
	Resale	Discount	Resale	Discount	Resale	Discount	Resale	Discount	Resale	Discount	Resale	Discount	Resale	Discount	Resale	Discount	Resale	Discount
1 Grandfathered Services (Note 1)	Yes	Yes	Yes	Yes	Yes	Yes	Yes	Yes	Yes	Yes	Yes	Yes	Yes	Yes	Yes	Yes	Yes	Yes
2 Promotions - > 90 Days (Note 2)	Yes	Yes	Yes	Yes	Yes	Yes	Yes	Yes	Yes	Yes	Yes	Yes	Yes	Yes	Yes	Yes	Yes	Note 3
3 Promotions - ≤ 90 Days (Note 2)	Yes	No	Yes	No	Yes	No	Yes	No	Yes	No	Yes	No	Yes	No	Yes	No	Yes	No
4 Lifeline/Link Up Services	Yes	Yes	Yes	Yes	Yes	Yes	Yes	Note 4	Yes	Yes	Yes	Yes	Yes	Yes	Yes	Yes	Yes	Yes
5 911/E911 Services	Yes	Yes	Yes	Yes	Yes	Yes	Yes	Yes	No	No	Yes	Yes	Yes	Yes	Yes	Yes	Yes	Yes
6 N11 Services	Yes	Yes	Yes	Yes	Yes	Yes	No	No	No	No	Yes	Yes	Yes	Yes	No	No	Yes	Yes
7 MemoryCall® Service	Yes	No	Yes	No	Yes	No	Yes	No	Yes	No	Yes	No	Yes	No	Yes	No	Yes	No
8 Mobile Services	Yes	No	Yes	No	Yes	No	Yes	No	Yes	No	Yes	No	Yes	No	Yes	No	Yes	No
9 Federal Subscriber Line Charges	Yes	No	Yes	No	Yes	No	Yes	No	Yes	No	Yes	No	Yes	No	Yes	No	Yes	No
10 Non-RecurCharges	Yes	Yes	Yes	Yes	Yes	Yes	Yes	Yes	Yes	Yes	Yes	Yes	Yes	Yes	Yes	Yes	Yes	No
11 End User Line Chg-Number Portability	Yes	No	Yes	No	Yes	No	Yes	No	Yes	No	Yes	No	Yes	No	Yes	No	Yes	No
12 Public Telephone Access Svc(PTAS)	Yes	Yes	Yes	Yes	Yes	Yes	Yes	Yes	Yes	Yes	Yes	Yes	Yes	Yes	Yes	No	Yes	Yes
13 Inside Wire Maint Service Plan	Yes	No	Yes	No	Yes	No	Yes	No	Yes	No	Yes	No	Yes	No	Yes	No	Yes	No
Applicable Notes:																		
1. Grandfathered services can be resold only to existing subscribers of the grandfathered service.																		
2. Where available for resale, promotions will be made available only to End Users who would have qualified for the promotion had it been provided by BellSouth directly.																		
3. In Tennessee, long-term promotions (offered for more than ninety (90) days) may be obtained at one of the following rates:																		
(a) the stated tariff rate, less the wholesale discount;																		
(b) the promotional rate (the promotional rate offered by BellSouth will not be discounted further by the wholesale discount rate)																		
4. Lifeline/Link Up services may be offered only to those subscribers who meet the criteria that BellSouth currently applies to subscribers of these services as set forth in Sections A3 and A4 of the BellSouth General Subscriber Services Tariff.																		
5. Some of BellSouth's local exchange and toll telecommunications services are not available in certain central offices and areas.																		

LINE INFORMATION DATA BASE (LIDB)

RESALE STORAGE AGREEMENT

I. Definitions (from Addendum)

- A. **Billing number** - a number used by BellSouth for the purpose of identifying an account liable for charges. This number may be a line or a special billing number.
- B. **Line number** - a ten-digit number assigned by BellSouth that identifies a telephone line associated with a resold local exchange service, or with a SPNP arrangement.
- C. **Special billing number** - a ten-digit number that identifies a billing account established by BellSouth in connection with a resold local exchange service or with a SPNP arrangement.
- D. **Calling Card number** - a billing number plus PIN number assigned by BellSouth.
- E. **PIN number** - a four digit security code assigned by BellSouth which is added to a billing number to compose a fourteen digit calling card number.
- F. **Toll billing exception indicator** - associated with a billing number to indicate that it is considered invalid for billing of collect calls or third number calls or both, by Heritage.
- G. **Billed Number Screening** - refers to the activity of determining whether a toll billing exception indicator is present for a particular billing number.
- H. **Calling Card Validation** - refers to the activity of determining whether a particular calling card number exists as stated or otherwise provided by a caller.
- I. **Billing number information** - information about billing number or Calling Card number as assigned by BellSouth and toll billing exception indicator provided to BellSouth by Heritage.

II. General

- A. This Agreement sets forth the terms and conditions pursuant to which BellSouth agrees to store in its LIDB certain information at the request of Heritage and pursuant to which BellSouth, its LIDB customers and Heritage shall have access to such information. In addition, this Agreement sets forth the terms and conditions for Heritage's provision of billing number information to BellSouth for inclusion in BellSouth's LIDB. Heritage understands that BellSouth provides access to

information in its LIDB to various telecommunications service providers pursuant to applicable tariffs and agrees that information stored at the request of Heritage, pursuant to this Agreement, shall be available to those telecommunications service providers. The terms and conditions contained herein shall hereby be made a part of this Interconnection/Resale Agreement upon notice to Heritage's account team to activate this LIDB Storage Agreement. The General Terms and Conditions of the Interconnection/Resale Agreement shall govern this LIDB Storage Agreement. The terms and conditions contained in the attached Addendum is hereby made a part of this LIDB Storage Agreement as if fully incorporated herein.

B. BellSouth will provide responses to on-line, call-by-call queries to billing number information for the following purposes:

1. Billed Number Screening

BellSouth is authorized to use the billing number information to determine whether Heritage has identified the billing number as one that should not be billed for collect or third number calls.

2. Calling Card Validation

BellSouth is authorized to validate a 14-digit Calling Card number where the first 10 digits are a line number or special billing number assigned by BellSouth, and where the last four digits (PIN) are a security code assigned by BellSouth.

3. Fraud Control

BellSouth will provide seven days per week, 24-hours per day, fraud monitoring on Calling Cards, bill-to-third and collect calls made to numbers in BellSouth's LIDB, provided that such information is included in the LIDB query. BellSouth will establish fraud alert thresholds and will notify Heritage of fraud alerts so that Heritage may take action it deems appropriate.

III. Responsibilities of the Parties

A. BellSouth will administer all data stored in the LIDB, including the data provided by Heritage pursuant to this Agreement, in the same manner as BellSouth's data for BellSouth's End User customers. BellSouth shall not be responsible to Heritage for any lost revenue which may result from BellSouth's administration of the LIDB pursuant to its established practices and procedures as they exist and as they may be changed by BellSouth in its sole discretion from time to time.

B. Billing and Collection Customers

BellSouth currently has in effect numerous billing and collection agreements with various interexchange carriers and billing clearing houses and as such these billing and collection

customers ("B&C Customers") query BellSouth's LIDB to determine whether to accept various billing options from End Users. Until such time as BellSouth implements in its LIDB and its supporting systems the means to differentiate Heritage's data from BellSouth's data, the following shall apply:

- (1) Heritage will accept responsibility for telecommunications services billed by BellSouth for its B&C Customers for Heritage's End User accounts which are resident in LIDB pursuant to this Agreement. Heritage authorizes BellSouth to place such charges on Heritage's bill from BellSouth and shall pay all such charges, including, but are not limited to, collect and third number calls.
- (2) Charges for such services shall appear on a separate BellSouth bill page identified with the name of the B&C Customers for which BellSouth is billing the charge.
- (3) Heritage shall have the responsibility to render a billing statement to its End Users for these charges, but Heritage shall pay BellSouth for the charges billed regardless of whether Heritage collects from Heritage's End Users.
- (4) BellSouth shall have no obligation to become involved in any disputes between Heritage and B&C Customers. BellSouth will not issue adjustments for charges billed on behalf of any B&C Customer to Heritage. It shall be the responsibility of Heritage and the B&C Customers to negotiate and arrange for any appropriate adjustments.

C. SPNP ARRANGEMENTS

1. BellSouth will include billing number information associated with resold exchange lines or SPNP arrangements in its LIDB. Heritage will request any toll billing exceptions via the Local Service Request (LSR) form used to order resold exchange lines, or the SPNP service request form used to order SPNP arrangements.
2. Under normal operating conditions, BellSouth shall include the billing number information in its LIDB upon completion of the service order establishing either the resold local exchange service or the SPNP arrangement, provided that BellSouth shall not be held responsible for any delay or failure in performance to the extent such delay or failure is caused by circumstances or conditions beyond BellSouth's reasonable control. BellSouth will store in its LIDB an unlimited volume of the working telephone numbers associated with either the resold local exchange lines or the SPNP arrangements. For resold local exchange lines or for SPNP arrangements, BellSouth will issue line-based calling cards only in the name of Heritage. BellSouth will not issue line-based calling cards in the name of Heritage's individual End Users. In the event that Heritage wants to include calling card numbers assigned by Heritage in the BellSouth LIDB, a separate agreement is required.

IV. Fees for Service and Taxes

- A. Heritage will not be charged a fee for storage services provided by BellSouth to Heritage, as described in this LIDB Resale Storage Agreement.
- B. Sales, use and all other taxes (excluding taxes on BellSouth's income) determined by BellSouth or any taxing authority to be due to any federal, state or local taxing jurisdiction with respect to the provision of the service set forth herein will be paid by Heritage in accordance with the tax provisions set forth in the General Terms and Conditions of this Agreement.

Optional Daily Usage File

1. Upon written request from Heritage, BellSouth will provide the Optional Daily Usage File (ODUF) service to Heritage pursuant to the terms and conditions set forth in this section.
2. Heritage shall furnish all relevant information required by BellSouth for the provision of the Optional Daily Usage File.
3. The Optional Daily Usage Feed will contain billable messages that were carried over the BellSouth Network and processed in the BellSouth Billing System, but billed to a Heritage customer.

Charges for delivery of the Optional Daily Usage File will appear on Heritage's monthly bills. The charges are as set forth in Exhibit E to this Attachment.

4. The Optional Daily Usage Feed will contain both rated and unrated messages. All messages will be in the standard Alliance for Telecommunications Industry Solutions (ATIS) EMI record format.
5. Messages that error in Heritage's billing system will be the responsibility of Heritage. If, however, Heritage should encounter significant volumes of errored messages that prevent processing by Heritage within its systems, BellSouth will work with Heritage to determine the source of the errors and the appropriate resolution.
6. The following specifications shall apply to the Optional Daily Usage Feed.

6.1 **Usage To Be Transmitted**

- 6.1.1 The following messages recorded by BellSouth will be transmitted to Heritage:

- Message recording for per use/per activation type services (examples: Three Way Calling, Verify, Interrupt, Call Return, etc.)
- Measured billable Local
- Directory Assistance messages
- IntraLATA Toll

- WATS and 800 Service
- N11

- Information Service Provider Messages
- Operator Services Messages
- Operator Services Message Attempted Calls (UNE only)
- Credit/Cancel Records
- Usage for Voice Mail Message Service

6.1.2 Rated Incollets (originated in BellSouth and from other companies) can also be on Optional Daily Usage File. Rated Incollets will be intermingled with BellSouth recorded rated and unrated usage. Rated Incollets will not be packed separately.

6.1.3 BellSouth will perform duplicate record checks on records processed to Optional Daily Usage File. Any duplicate messages detected will be deleted and not sent to Heritage.

6.1.4 In the event that Heritage detects a duplicate on Optional Daily Usage File they receive from BellSouth, Heritage will drop the duplicate message (Heritage will not return the duplicate to BellSouth).

6.2 Physical File Characteristics

6.2.1 The Optional Daily Usage File will be distributed to Heritage via an agreed medium with CONNECT:Direct being the preferred transport method. The Daily Usage Feed will be a variable block format (2476) with an LRECL of 2472. The data on the Daily Usage Feed will be in a non-compacted EMI format (175 byte format plus modules). It will be created on a daily basis (Monday through Friday except holidays). Details such as dataset name and delivery schedule will be addressed during negotiations of the distribution medium. There will be a maximum of one dataset per workday per OCN.

6.2.2 Data circuits (private line or dial-up) will be required between BellSouth and Heritage for the purpose of data transmission. Where a dedicated line is required, Heritage will be responsible for ordering the circuit, overseeing its installation and coordinating the installation with BellSouth. Heritage will also be responsible for any charges associated with this line. Equipment required on the BellSouth end to attach the line to the mainframe computer and to transmit successfully ongoing will be negotiated on a case by case basis. Where a dial-up facility is required, dial circuits will be installed in the BellSouth data center by BellSouth and the associated charges assessed to Heritage. Additionally, all message toll charges associated with the use of the dial circuit by Heritage will be the responsibility of Heritage. Associated equipment on the BellSouth end, including a modem, will be negotiated on a case by case basis between the Parties. All equipment, including modems and software, that is required on

Heritage end for the purpose of data transmission will be the responsibility of Heritage.

6.3 Packing Specifications

6.3.1 A pack will contain a minimum of one message record or a maximum of 99,999 message records plus a pack header record and a pack trailer record. One transmission can contain a maximum of 99 packs and a minimum of one pack.

6.3.2 The OCN, From RAO, and Invoice Number will control the invoice sequencing. The From RAO will be used to identify to Heritage which BellSouth RAO is sending the message. BellSouth and Heritage will use the invoice sequencing to control data exchange. BellSouth will be notified of sequence failures identified by Heritage and resend the data as appropriate.

THE DATA WILL BE PACKED USING ATIS EMI RECORDS.

6.4 Pack Rejection

6.4.1 Heritage will notify BellSouth within one business day of rejected packs (via the mutually agreed medium). Packs could be rejected because of pack sequencing discrepancies or a critical edit failure on the Pack Header or Pack Trailer records (i.e. out-of-balance condition on grand totals, invalid data populated). Standard ATIS EMI Error Codes will be used. Heritage will not be required to return the actual rejected data to BellSouth. Rejected packs will be corrected and retransmitted to Heritage by BellSouth.

6.5 Control Data

Heritage will send one confirmation record per pack that is received from BellSouth. This confirmation record will indicate Heritage received the pack and the acceptance or rejection of the pack. Pack Status Code(s) will be populated using standard ATIS EMI error codes for packs that were rejected by Heritage for reasons stated in the above section.

6.6 Testing

6.6.1 Upon request from Heritage, BellSouth shall send test files to Heritage for the Optional Daily Usage File. The Parties agree to review and discuss the file's content and/or format. For testing of usage results, BellSouth shall request that Heritage set up a production (LIVE) file. The live test may consist of Heritage's employees making test calls for the types of services Heritage requests on the Optional Daily Usage File. These test calls are logged by Heritage, and the logs are provided to BellSouth. These logs will be used to verify the files. Testing will be completed within 30 calendar days from the date on which the initial test file was sent.

Enhanced Optional Daily Usage File

1. Upon written request from Heritage, BellSouth will provide the Enhanced Optional Daily Usage File (EODUF) service to Heritage pursuant to the terms and conditions set forth in this section. EODUF will only be sent to existing ODUF subscribers who request the EODUF option.
2. Heritage shall furnish all relevant information required by BellSouth for the provision of the Enhanced Optional Daily Usage File.
3. The Enhanced Optional Daily Usage File (EODUF) will provide usage data for local calls originating from resold Flat Rate Business and Residential Lines.
4. Charges for delivery of the Enhanced Optional Daily Usage File will appear on Heritage's monthly bills. The charges are as set forth in Exhibit E to this Attachment.
5. All messages will be in the standard Alliance for Telecommunications Industry Solutions (ATIS) EMI record format.
6. Messages that error in the billing system of Heritage will be the responsibility of Heritage. If, however, Heritage should encounter significant volumes of errored messages that prevent processing by Heritage within its systems, BellSouth will work with Heritage to determine the source of the errors and the appropriate resolution.
7. The following specifications shall apply to the Optional Daily Usage Feed.
 - 7.1 **Usage To Be Transmitted**
 - 7.1.1 The following messages recorded by BellSouth will be transmitted to Heritage:

Customer usage data for flat rated local call originating from Heritage's End User lines (1FB or 1FR). The EODUF record for flat rate messages will include:

Date of Call

From Number

To Number

Connect Time

Conversation Time

Method of Recording

From RAO

Rate Class

Message Type

Billing Indicators

Bill to Number

7.1.2 BellSouth will perform duplicate record checks on EODUF records processed to Optional Daily Usage File. Any duplicate messages detected will be deleted and not sent to Heritage.

7.1.3 In the event that Heritage detects a duplicate on Enhanced Optional Daily Usage File they receive from BellSouth, Heritage will drop the duplicate message (Heritage will not return the duplicate to BellSouth).

7.2 Physical File Characteristics

7.2.1 The Enhanced Optional Daily Usage Feed will be distributed to Heritage over their existing Optional Daily Usage File (ODUF) feed. The EODUF messages will be intermingled among Heritage's Optional Daily Usage File (ODUF) messages. The EODUF will be a variable block format (2476) with an LRECL of 2472. The data on the EODUF will be in a non-compacted EMI format (175 byte format plus modules). It will be created on a daily basis (Monday through Friday except holidays).

7.2.2 Data circuits (private line or dial-up) may be required between BellSouth and Heritage for the purpose of data transmission. Where a dedicated line is required, Heritage will be responsible for ordering the circuit, overseeing its installation and coordinating the installation with BellSouth. Heritage will also be responsible for any charges associated with this line. Equipment required on the BellSouth end to attach the line to the mainframe computer and to transmit successfully ongoing will be negotiated on a case by case basis. Where a dial-up facility is required, dial circuits will be installed in the BellSouth data center by BellSouth and the associated charges assessed to Heritage. Additionally, all message toll charges associated with the use of the dial circuit by Heritage will be the responsibility of Heritage. Associated equipment on the BellSouth end, including a modem, will be negotiated on a case by case basis between the Parties. All equipment, including modems and software, that is required on Heritage's end for the purpose of data transmission will be the responsibility of Heritage.

7.3 Packing Specifications

7.3.1 A pack will contain a minimum of one message record or a maximum of 99,999 message records plus a pack header record and a pack trailer record. One transmission can contain a maximum of 99 packs and a minimum of one pack.

7.3.2 The Operating Company Number (OCN), From Revenue Accounting Office (RAO), and Invoice Number will control the invoice sequencing. The From RAO will be used to identify to Heritage which BellSouth RAO is sending the message. BellSouth and Heritage will use the invoice sequencing to control data exchange. BellSouth will be notified of sequence failures identified by Heritage and resend the data as appropriate.

THE DATA WILL BE PACKED USING ATIS EMI RECORDS.

RESALE DISCOUNTS AND RATES

Attachment I
Exhibit E

	ALABAMA	FLORIDA	GEORGIA	KENTUCKY	LOUISIANA	MISSISSIPPI	NORTH CAROLINA	SOUTH CAROLINA	TENNESSEE	
RESIDENCE	16.3%	21.83%	20.3%	16.79%	20.72%	15.75%	21.5%	14.8%	16%	
BUSINESS	16.3%	16.81%	17.3%	15.54%	20.72%	15.75%	17.6%	14.8%	16%	
CSAs*					9.05%			8.98%		
* Unless noted in this row, the discount for Business will be the applicable discount rate for CSAs.										
ELEMENT	USOC									
Electronic LSR	SOME C	\$3.50	\$3.50	\$3.50	\$3.50	\$3.50	\$3.50	\$3.50	\$3.50	
Manual LSR	SOMAN	\$19.99	\$19.99	\$19.99	\$19.99	\$19.99	\$19.99	\$19.99	\$19.99	
ENHANCED OPTION DAILY USAGE FILE (EODUF)										
EODUF: Message Processing, per message		\$0.004	\$0.004	\$0.0034555	\$0.004	\$0.004	\$0.004	\$0.004	\$0.004	
OPTIONAL DAILY USAGE FILE (ODUF)										
ODUF: Recording, per message		\$0.0002	\$0.004	\$0.0001275	\$0.0008611	\$0.00019	\$0.0001179	\$0.0003	\$0.0002862	\$0.0000044
ODUF: Message Processing, per message		\$0.0033	\$0.008	\$0.0082548	\$0.0032357	\$0.0024	\$0.0032089	\$0.0032	\$0.0032344	\$0.0027366
ODUF: Message Processing, per Magnetic Tape provisioned		\$55.19	\$54.95	\$28.85	\$55.68	\$47.30	\$54.62	\$54.61	\$54.72	\$52.75
ODUF: Data Transmission (CONNECT:DIRECT), per msg		\$0.00004	\$0.0001	\$0.0000434	\$0.0000365	\$0.00003	\$0.0000354	\$0.0004	\$0.0000357	\$0.0000339

Attachment 2

Network Elements and Other Services

TABLE OF CONTENTS

1. INTRODUCTION.....	3
2. UNBUNDLED LOOPS	4
3. HIGH FREQUENCY SPECTRUM NETWORK ELEMENT.....	24
4. LOCAL SWITCHING.....	28
5. UNBUNDLED NETWORK ELEMENT COMBINATIONS.....	34
6. TRANSPORT, CHANNELIZATION AND DARK FIBER	41
7. BELLSOUTH SWITCHED ACCESS (“SWA”) 8XX TOLL FREE DIALING TEN DIGIT SCREENING SERVICE.....	46
8. LINE INFORMATION DATABASE (LIDB).....	47
9. SIGNALING	49
10. OPERATOR SERVICE AND DIRECTORY ASSISTANCE	55
11. AUTOMATIC LOCATION IDENTIFICATION/DATA MANAGEMENT SYSTEM (ALI/DMS).....	60
12. CALLING NAME (CNAM) DATABASE SERVICE.....	61
13. SERVICE CREATION ENVIRONMENT AND SERVICE MANAGEMENT SYSTEM (SCE/SMS) ADVANCED INTELLIGENT NETWORK (AIN) ACCESS	63
14. BASIC 911 AND E911	63
15. OPERATIONAL SUPPORT SYSTEMS (OSS).....	64
LIDB Storage Agreement	Exhibit A
Rates	Exhibit B

ACCESS TO NETWORK ELEMENTS AND OTHER SERVICES

1. Introduction

- 1.1 This Attachment sets forth rates, terms and conditions for Network Elements and combinations of Network Elements that BellSouth agrees to offer to Heritage in accordance with its obligations under Section 251(c)(3) of the Act. Additionally, this Attachment sets forth the rates, terms and conditions for other services BellSouth makes available to Heritage. The price for each Network Element and combination of Network Elements and other services are set forth in Exhibit B of this Agreement. Additionally, the provision of a particular Network Element or service may require Heritage to purchase other Network Elements or services.
- 1.2 For purposes of this Agreement, "Network Element" is defined to mean a facility or equipment Heritage used in the provision of a telecommunications service. For purposes of this Agreement, combinations of Network Elements shall be referred to as "Combinations."
- 1.3 BellSouth shall, upon request of Heritage, and to the extent technically feasible, provide to Heritage access to its Network Elements for the provision of Heritage's telecommunications services. If no rate is identified in this Agreement, the rate for the specific service or function will be as set forth in the applicable BellSouth tariff or as negotiated by the Parties upon request by either Party.
- 1.4 Heritage may purchase Network Elements and other services from BellSouth for the purpose of combining such network elements in any manner Heritage chooses to provide telecommunication services to its intended users, including recreating existing BellSouth services. With the exception of the sub-loop Network Elements which are located outside of the central office, BellSouth shall deliver the Network Elements purchased by Heritage to the designated Heritage collocation space.
- 1.5 BellSouth shall comply with the requirements as set forth in the technical references within this Attachment 2.
- 1.6 **Rates**
- 1.6.1 The prices that Heritage shall pay to BellSouth for Network Elements and Other Services are set forth in Exhibit B to this Attachment. If Heritage purchases a service(s) from a tariff, all terms and conditions and rates as set forth in such tariff shall apply.
- 1.6.2 **Cancellation Charges.** If Heritage cancels an order for Network Elements or other services, any costs incurred by BellSouth in conjunction with the provisioning of that order will be recovered in accordance with FCC No. 1 Tariff, Section 5.

- 1.6.3 Expedite Charges. For expedited requests by Heritage, expedited charges will apply for intervals less than the standard interval as outlined in the BellSouth Product and Services Interval Guide. The charges as outlined in BellSouth's FCC No. 1 Tariff, Section 5, will apply.
- 1.6.4 Order cancellation and expedite charges will apply in accordance with the terms and conditions specified in Attachment 6.
- 1.6.5 If Heritage modifies an order (Order Modification Charge (OMC)) after being sent a Firm Order Confirmation (FOC) from BellSouth, any costs incurred by BellSouth to accommodate the modification will be paid by Heritage in accordance with FCC No. 1 Tariff, Section 5.
- 1.6.6 A one-month minimum billing period shall apply to all UNE conversions or new installations.
- 2. Unbundled Loops**
- 2.1 General**
- 2.1.1 The local loop Network Element ("Loop") is defined as a transmission facility between a distribution frame (or its equivalent) in BellSouth's central office and the loop demarcation point at an end-user customer premises, including inside wire owned by BellSouth. The local loop Network Element includes all features, functions, and capabilities of the transmission facilities, including dark fiber and attached electronics (except those used for the provision of advanced services, such as Digital Subscriber Line Access Multiplexers) and line conditioning.
- 2.1.2 The provisioning of a Loop to Heritage's collocation space will require cross-office cabling and cross-connections within the central office to connect the Loop to a local switch or to other transmission equipment. These cross-connects are separate components, that are not considered a part of the Loop, and thus, have a separate charge.
- 2.1.3 To the extent available within BellSouth's network at a particular location, BellSouth will offer Loops capable of supporting telecommunications services. If a requested loop type is not available, and cannot be made available through BellSouth's Unbundled Loop Modification process, then Heritage can use the Special Construction process to request that BellSouth place facilities in order to meet Heritage's loop requirements. Standard Loop intervals shall not apply to the Special Construction process.
- 2.1.4 Where facilities are available, BellSouth will install Loops in compliance with BellSouth's Products and Services Interval Guide available at the website at <http://www.interconnection.bellsouth.com>. For orders of 15 or more Loops, the installation and any applicable Order Coordination as described below will be handled on a project basis, and the intervals will be set by the BellSouth project

manager for that order. When Loops require a Service Inquiry (SI) prior to issuing the order to determine if facilities are available, the interval for the SI process is separate from the installation interval.

- 2.1.5 The Loop shall be provided to Heritage in accordance with BellSouth's TR73600 Unbundled Local Loop Technical Specification and applicable industry standard technical references.
- 2.1.6 Heritage may utilize the unbundled Loops to provide any telecommunications service it wishes, so long as such services are consistent with industry standards and BellSouth's TR73600.
- 2.1.7 BellSouth will only provision, maintain and repair the Loops to the standards that are consistent with the type of Loop ordered. In those cases where Heritage has requested that BellSouth modify a Loop so that it no longer meets the technical parameters of the original Loop type (e.g., voice grade, ISDN, ADSL, etc.) the resulting Loop will be maintained as an unbundled copper Loop (UCL), and Heritage shall pay the recurring and non-recurring charges for a UCL. For non-service specific loops (e.g. UCL, Loops modified by Heritage using the Unbundled Loop Modification (ULM) process), BellSouth will only support that the Loop has copper continuity and balanced tip-and-ring.
- 2.1.8 **Loop Testing/Trouble Reporting**
- 2.1.8.1 Heritage is responsible for testing and isolating troubles on the Loops. Heritage must test and isolate trouble to the BellSouth portion of a designed unbundled loop (e.g., UVL-SL2, UCL-D, etc.) before reporting repair to the UNE Center. At the time of the trouble report, Heritage will be required to provide the results of the Heritage test which indicate a problem on the BellSouth provided loop.
- 2.1.8.2 Once Heritage has isolated a trouble to the BellSouth provided Loop, and had issued a trouble report to BellSouth on the Loop, BellSouth will take the actions necessary to repair the Loop if a trouble actually exists. BellSouth will repair these Loops in the same time frames that BellSouth repairs similarly situated Loops to its end users.
- 2.1.8.3 If Heritage reports a trouble on a non-designed loop (e.g., UVL-SL1, UCL-ND, etc.) and no trouble actually exists, BellSouth will charge Heritage for any dispatching and testing (both inside and outside the CO) required by BellSouth in order to confirm the loop's working status.
- 2.1.9 **Order Coordination and Order Coordination-Time Specific**
- 2.1.9.1 "Order Coordination" (OC) allows BellSouth and Heritage to coordinate the installation of the SL2 Loops, Unbundled Digital Loops (UDL) and other Loops where OC may be purchased as an option, to Heritage's facilities to limit end user service outage. OC is available when the Loop is provisioned over an existing

circuit that is currently providing service to the end user. OC for physical conversions will be scheduled at BellSouth's discretion during normal working hours on the committed due date. OC shall be provided in accordance with the chart set forth below.

- 2.1.9.2 “Order Coordination – Time Specific” (OC-TS) allows Heritage to order a specific time for OC to take place. BellSouth will make every effort to accommodate Heritage's specific conversion time request. However, BellSouth reserves the right to negotiate with Heritage a conversion time based on load and appointment control when necessary. This OC-TS is a chargeable option for all Loops except Unbundled Copper Loops (UCL) and Universal Digital Channel (UDC), and is billed in addition to the OC charge. Heritage may specify a time between 9:00 a.m. and 4:00 p.m. (location time) Monday through Friday (excluding holidays). If Heritage specifies a time outside this window, or selects a time or quantity of Loops that requires BellSouth technicians to work outside normal work hours, overtime charges will apply in addition to the OC and OC-TS charges. Overtime charges will be applied based on the amount of overtime worked and in accordance with the rates established in the E Access Tariff, Section E13.2, for each state. The OC-TS charges for an order due on the same day at the same location will be applied on a per Local Service Request (LSR) basis.

	Order Coordination (OC)	Order Coordination - Time Specific (OC-TS)	Test Points	DLR	Charge for Dispatch and Testing if No Trouble Found
SL-1	Chargeable Option	Chargeable Option	Not available	Chargeable Option – ordered as Engineering Information Document	Charged for Dispatch inside and outside Central Office
UCL-ND	Chargeable Option	Not Available	Not Available	Chargeable Option – ordered as Engineering Information Document	Charged for Dispatch inside and outside Central Office
SL-2	Included	Chargeable Option	Included	Included	Charged for Dispatch outside Central Office
Unbundled Digital Loop	Included	Chargeable Option (except on Universal Digital Channel)	Included (where appropriate)	Included	Charged for Dispatch outside Central Office
Unbundled Copper Loop	Chargeable in accordance with Section 2	Not available	Included	Included	Charged for Dispatch outside Central Office
For UVL-SL1 and UCLs, Heritage must order and will be billed for both OC and OC-TS if requesting OC-TS.					

2.2 Unbundled Voice Loops (UVLs)

2.2.1 BellSouth shall make available the following UVLs:

2.2.1.1 2-wire Analog Voice Grade Loop – SL1

2.2.1.2 2-wire Analog Voice Grade Loop – SL2

2.2.1.3 4-wire Analog Voice Grade Loop

2.2.2 Unbundled Voice Loops (UVL) may be provisioned using any type of facility that will support voice grade services. This may include loaded copper, non-loaded copper, digital loop carrier systems, fiber or a combination of any of these facilities. BellSouth, in the normal course of maintaining, repairing, and

configuring its network, may also change the facilities that are used to provide any given voice grade circuit. This change may occur at any time. In these situations, BellSouth will only ensure that the newly provided facility will support voice grade services. BellSouth will not guarantee that Heritage will be able to continue to provide any advanced services over the new facility. BellSouth will offer UVL in two different service levels - Service Level One (SL1) and Service Level Two (SL2).

2.2.3 Unbundled Voice Loop - SL1 (UVL-SL1) loops are 2-wire loop start circuits, will be non-designed, and will not have remote access test points. OC will be offered as a chargeable option on SL1 loops when reuse of existing facilities has been requested by Heritage. Heritage may also order OC-TS when a specified conversion time is requested. OC-TS is a chargeable option for any coordinated order and is billed in addition to the OC charge. An Engineering Information (EI) document can be ordered as chargeable option. The EI document provides loop make up information which is similar to the information normally provided in a Design Layout Record. Upon issuance of a non-coordinated order in the service order system, SL1 loops will be activated on the due date in the same manner and time frames that BellSouth normally activates POTS-type loops for its end users.

2.2.4 Unbundled Voice Loop – SL2 (UVL-SL2) loops may be 2-wire or 4-wire circuits, shall have remote access test points, and will be designed with a Design Layout Record provided to Heritage. SL2 circuits can be provisioned with loop start, ground start or reverse battery signaling. OC is provided as a standard feature on SL2 loops. The OC feature will allow Heritage to coordinate the installation of the loop with the disconnect of an existing customer's service and/or number portability service. In these cases, BellSouth will perform the order conversion with standard order coordination at its discretion during normal work hours.

2.3 Unbundled Digital Loops

2.3.1 BellSouth will offer Unbundled Digital Loops (UDL). UDLs are service specific, will be designed, will be provisioned with test points (where appropriate), and will come standard with OC and a Design Layout Record (DLR). The various UDLs are intended to support a specific digital transmission scheme or service.

2.3.2 BellSouth shall make available the following UDLs:

2.3.2.1 2-wire Unbundled ISDN Digital Loop

2.3.2.2 2-wire Universal Digital Channel (IDSL Compatible)

2.3.2.3 2-wire Unbundled ADSL Compatible Loop

2.3.2.4 2-wire Unbundled HDSL Compatible Loop

2.3.2.5 4-wire Unbundled HDSL Compatible Loop

- 2.3.2.6 4-wire Unbundled DS1 Digital Loop
- 2.3.2.7 4-wire Unbundled Digital Loop/DS0 – 64 kbps, 56 kbps and below
- 2.3.2.8 DS3 Loop
- 2.3.2.9 STS-1 Loop
- 2.3.2.10 OC3 Loop
- 2.3.2.11 OC12 Loop
- 2.3.2.12 OC48 Loop
- 2.3.3 2-Wire Unbundled ISDN Digital Loops will be provisioned according to industry standards for 2-Wire Basic Rate ISDN services and will come standard with a test point, Order Coordination, and a DLR. Heritage will be responsible for providing BellSouth with a Service Profile Identifier (SPID) associated with a particular ISDN-capable loop and end user. With the SPID, BellSouth will be able to adequately test the circuit and ensure that it properly supports ISDN service. BellSouth will not reconfigure its ISDN-capable loop to support IDSL service.
- 2.3.3.1 The Universal Digital Channel (UDC) (also known as IDSL-compatible Loop) is intended to be compatible with IDSL service and has the same physical characteristics and transmission specifications as BellSouth's ISDN-capable loop. These specifications are listed in BellSouth's TR73600.
- 2.3.3.2 The UDC may be provisioned on copper or through a Digital Loop Carrier (DLC) system. When UDC Loops are provisioned using a DLC system, the Loops will be provisioned on time slots that are compatible with data-only services such as IDSL.
- 2.3.4 2-Wire ADSL-Compatible Loop. This is a designed loop that is provisioned according to Revised Resistance Design (RRD) criteria and may be up to 18kft long and may have up to 6kft of bridged tap (inclusive of loop length). The loop is a 2-wire circuit and will come standard with a test point, Order Coordination, and a DLR.
- 2.3.5 2-Wire or 4-Wire HDSL-Compatible Loop. This is a designed loop that is provisioned according to Carrier Serving Area (CSA) criteria and may be up to 12,000 feet long and may have up to 2,500 feet of bridged tap (inclusive of loop length). It may be a 2-wire or 4-wire circuit and will come standard with a test point, Order Coordination, and a DLR.

- 2.3.6 4-Wire Unbundled DS1 Digital Loop. This is a designed 4-wire loop that is provisioned according to industry standards for DS1 or Primary Rate ISDN services and will come standard with a test point, Order Coordination, and a DLR.
- 2.3.7 4-Wire Unbundled Digital/DS0 Loop. These are designed 4-wire loops that may be configured as 64kbps, 56kbps, 19kbps, and other sub-rate speeds associated with digital data services and will come standard with a test point, Order Coordination, and a DLR.
- 2.3.8 DS3 Loop. DS3 Loop is a two-point digital transmission path, which provides for simultaneous two-way transmission of serial, bipolar, return-to-zero isochronous digital electrical signals at a transmission rate of 44.736 megabits per second (Mbps) that is dedicated to the use of the ordering CLEC in its provisioning of local exchange and associated exchange access services. It may provide transport for twenty-eight (28) DS1 channels, each of which provides the digital equivalent of twenty-four analog voice grade channels. The interface to unbundled dedicated DS3 transport is a metallic-based electrical interface.
- 2.3.9 STS-1 Loop. STS-1 Loop is a high-capacity digital transmission path with SONET VT1.5 mapping that is dedicated for the use of the ordering customer for the purpose of provisioning local exchange and associated exchange access services. It is a two-point digital transmission path, which provides for simultaneous two-way transmission of serial bipolar return-to-zero synchronous digital electrical signals at a transmission rate of 51.84 megabits per second (Mbps). It may provide transport for twenty-eight (28) DS1 channels, each of which provides the digital equivalent of twenty-four analog voice grade channels. The interface to unbundled dedicated STS-1 transport is a metallic-based electrical interface.
- 2.3.10 OC3 Loop/OC12 Loop/OC48 Loop. OC3/OC-12/OC-48 Loops are optical two-point transmission paths that are dedicated to the use of the ordering CLEC in its provisioning of local exchange and associated exchange access services. The physical interface for all optical transport is optical fiber. This interface standard allows for transport of many different digital signals using a basic building block or base transmission rate of 51.84 megabits per second (Mbps). Higher rates are direct multiples of the base rate. The following rates are applicable: OC-3 - 155.52 Mbps; OC12 - 622.08 Mbps; and OC-48 - 2488 Mbps.
- 2.3.11 DS3 and above services come with a test point and a DLR. Mileage is airline miles, rounded up and a minimum of one mile applies. BellSouth TR 73501 LightGate® Service Interface and Performance Specifications, Issue D, June 1995 applies to DS3 and above services.
- 2.4 **Unbundled Copper Loops (UCL)**

2.4.1 BellSouth shall make available Unbundled Copper Loops (UCLs). The UCL is a copper twisted pair Loop that is unencumbered by any intervening equipment (e.g., filters, load coils, range extenders, digital loop carrier, or repeaters) and is not intended to support any particular telecommunications service. The UCL will be offered in two types – Designed and Non-Designed.

2.4.2 **Unbundled Copper Loop – Designed (UCL-D)**

2.4.2.1 The UCL-D will be provisioned as a dry copper twisted pair loop that is unencumbered by any intervening equipment (e.g., filters, load coils, range extenders, digital loop carrier, or repeaters). The UCL-D will be offered in two versions - Short and Long.

2.4.2.2 A short UCL-D (18,000 feet or less) is provisioned according to Resistance Design parameters, may have up to 6,000 feet of bridged tap and will have up to 1300 ohms of resistance.

2.4.2.3 The long UCL-D (beyond 18,000 feet) is provisioned as a dry copper twisted pair longer than 18,000 feet and may have up to 12,000 feet of bridged tap and up to 2800 ohms of resistance.

2.4.2.4 The UCL-D is a designed circuit, is provisioned with a test point and comes standard with a DLR. OC is required on UCLs where a reuse of existing facilities has been requested by Heritage.

2.4.2.5 These loops are not intended to support any particular services and may be utilized by Heritage to provide a wide-range of telecommunications services so long as those services do not adversely affect BellSouth's network. This facility will include a Network Interface Device (NID) at the customer's location for the purpose of connecting the loop to the customer's inside wire.

2.4.2.6 BellSouth will make available the following UCL-Ds:

2.4.2.6.1 2-Wire UCL-D/short

2.4.2.6.2 2-Wire UCL-D/long

2.4.2.6.3 4-Wire UCL-D/short

2.4.2.6.4 4-Wire UCL-D/long

2.4.3 **Unbundled Copper Loop – Non-Designed (UCL-ND)**

2.4.3.1 The UCL-ND is provisioned as a dedicated 2-wire metallic transmission facility from BellSouth's Main Distribution Frame to a customer's premises (including the NID). The UCL-ND will be a "dry copper" facility in that it will not have any intervening equipment such as load coils, repeaters, or digital access main lines

("DAMLs"), and may have up to 6,000 feet of bridged tap between the end user's premises and the serving wire center. The UCL-ND typically will be 1300 Ohms resistance and in most cases will not exceed 18,000 feet in length, although the UCL-ND will not have a specific length limitation. For loops less than 18,000 feet and with less than 1300 Ohms resistance, the loop will provide a voice grade transmission channel suitable for loop start signaling and the transport of analog voice grade signals. The UCL-ND will not be designed and will not be provisioned with either a DLR or a test point.

- 2.4.3.2 The UCL-ND facilities may be mechanically assigned using BellSouth's assignment systems. Therefore, the Loop Make Up process is not required to order and provision the UCL-ND. However, Heritage can request Loop Make Up for which additional charges would apply.
- 2.4.3.3 At an additional charge, BellSouth also will make available Loop Testing so that Heritage may request further testing on the UCL-ND.
- 2.4.3.4 UCL-ND loops are not intended to support any particular service and may be utilized by Heritage to provide a wide-range of telecommunications services so long as those services do not adversely affect BellSouth's network. The UCL-ND will include a Network Interface Device (NID) at the customer's location for the purpose of connecting the loop to the customer's inside wire.
- 2.4.3.5 Order Coordination (OC) will be provided as a chargeable option and may be utilized when the UCL-ND provisioning is associated with the reuse of BellSouth facilities. Order Coordination -Time Specific (OC-TS) does not apply to this product.
- 2.4.3.6 Heritage may use BellSouth's Unbundled Loop Modification (ULM) offering to remove bridge tap and/or load coils from any loop within the BellSouth network. Therefore, some loops that would not qualify as UCL-ND could be transformed into loops that do qualify, using the ULM process.

2.5 **Unbundled Loop Modifications (Line Conditioning)**

- 2.5.1 **Line Conditioning** is defined as the removal from the Loop of any devices that may diminish the capability of the Loop to deliver high-speed switched wireline telecommunications capability, including xDSL service. Such devices include, but are not limited to, load coils, bridged taps, low pass filters, and range extenders.
- 2.5.2 BellSouth shall condition Loops, as requested by Heritage, whether or not BellSouth offers advanced services to the End User on that Loop.
- 2.5.3 In some instances, Heritage will require access to a copper twisted pair loop unfettered by any intervening equipment (e.g., filters, load coils, range extenders, etc.), so that Heritage can use the loop for a variety of services by attaching appropriate terminal equipment at the ends. Heritage will determine the type of

service that will be provided over the loop. BellSouth's Unbundled Loop Modifications (ULM) process will be used to determine the costs and feasibility of conditioning the loops as requested. Rates for ULM are as set forth in Exhibit B of this Attachment.

2.5.4 In those cases where Heritage has requested that BellSouth modify a Loop so that it no longer meets the technical parameters of the original Loop type (e.g., voice grade, ISDN, ADSL, etc.) the resulting modified Loop will be ordered and maintained as a UCL.

2.5.5 The Unbundled Loop Modifications (ULM) offering provides the following elements: 1) removal of devices on 2-wire or 4-wire Loops equal to or less than 18,000 feet; 2) removal of devices on 2-wire or 4-wire Loops longer than 18,000 feet; and 3) removal of bridged-taps on loops of any length.

2.5.6 Heritage shall request Loop make up information pursuant to this Attachment prior to submitting a service inquiry and/or a LSR for the Loop type that Heritage desires BellSouth to condition.

2.6 **Loop Provisioning Involving Integrated Digital Loop Carriers**

2.6.1 Where Heritage has requested an Unbundled Loop and BellSouth uses Integrated Digital Loop Carrier (IDLC) systems to provide the local service to the end user and BellSouth has a suitable alternate facility available, BellSouth will make such alternative facilities available to Heritage. If a suitable alternative facility is not available, then to the extent it is technically feasible, BellSouth will make alternative arrangements available to Heritage (e.g. hairpinning).

2.6.2 BellSouth will select one of the following arrangements:

1. Roll the circuit(s) from the IDLC to any spare copper that exists to the customer premises.
2. Roll the circuit(s) from the IDLC to an existing DLC that is not integrated.
3. If capacity exists, provide "side-door" porting through the switch.
4. If capacity exists, provide "DACS-door" porting (if the IDLC routes through a DACS prior to integration into the switch).

2.6.3 Arrangements 3 and 4 above require the use of a designed circuit. Therefore, non-designed loops such as the SL1 voice grade and UCL-ND may not be ordered in these cases.

2.6.4 If no alternate facility is available, BellSouth will utilize its Special Construction (SC) process to determine the additional costs required to provision the loop facilities. Heritage will then have the option of paying the one-time SC rates to place the loop.

2.7 **Network Interface Device (NID)**

- 2.7.1 The NID is defined as any means of interconnection of end-user customer premises wiring to BellSouth's distribution plant, such as a cross-connect device used for that purpose. The NID is a single-line termination device or that portion of a multiple-line termination device required to terminate a single line or circuit at the premises. The NID features two independent chambers or divisions that separate the service provider's network from the end user's customer-premises wiring. Each chamber or division contains the appropriate connection points or posts to which the service provider and the end user each make their connections. The NID provides a protective ground connection and is capable of terminating cables such as twisted pair cable.
- 2.7.1.1 BellSouth shall permit Heritage to connect Heritage's Loop facilities the end-user's customer-premises wiring through the BellSouth NID or at any other technically feasible point.
- 2.7.2 **Access to NID**
- 2.7.2.1 Heritage may access the end user's customer-premises wiring by any of the following means and Heritage shall not disturb the existing form of electrical protection and shall maintain the physical integrity of the NID:
- 2.7.2.1.1 1) BellSouth shall allow Heritage to connect its loops directly to BellSouth's multi-line residential NID enclosures that have additional space and are not used by BellSouth or any other telecommunications carriers to provide service to the premises.
- 2.7.2.1.2 2) Where an adequate length of the end user's customer premises wiring is present and environmental conditions permit, either Party may remove the customer premises wiring from the other Party's NID and connect such wiring to that Party's own NID;
- 2.7.2.1.3 3) Enter the subscriber access chamber or dual chamber NID enclosures for the purpose of extending a connect divisioned or spliced jumper wire from the customer premises wiring through a suitable "punch-out" hole of such NID enclosures; or
- 2.7.2.1.4 4) Request BellSouth to make other rearrangements to the end user customer premises wiring terminations or terminal enclosure on a time and materials cost basis.
- 2.7.2.2 In no case shall either Party remove or disconnect the other Party's loop facilities from either Party's NIDs, enclosures, or protectors unless the applicable Commission has expressly permitted the same and the disconnecting Party provides prior notice to the other Party. In such cases, it shall be the responsibility of the Party disconnecting loop facilities to leave undisturbed the existing form of electrical protection and to maintain the physical integrity of the NID. It will be

Heritage's responsibility to ensure there is no safety hazard and will hold BellSouth harmless for any liability associated with the removal of the BellSouth loop from the BellSouth NID. Furthermore, it shall be the responsibility of the disconnecting Party, once the other Party's loop has been disconnected from the NID, to reconnect the disconnected loop to a nationally recognized testing laboratory listed station protector, which has been grounded as per Article 800 of the National Electrical Code. If no spare station protector exists in the NID, the disconnected loop must be appropriately cleared, capped and stored.

- 2.7.2.3 In no case shall either Party remove or disconnect ground wires from BellSouth's NIDs, enclosures, or protectors.
- 2.7.2.4 In no case shall either Party remove or disconnect NID modules, protectors, or terminals from BellSouth's NID enclosures.
- 2.7.2.5 Due to the wide variety of NID enclosures and outside plant environments, BellSouth will work with Heritage to develop specific procedures to establish the most effective means of implementing this section if the procedures set forth herein do not apply to the NID in question.
- 2.7.3 **Technical Requirements**
- 2.7.3.1 The NID shall provide an accessible point of interconnection and shall maintain a connection to ground.
- 2.7.3.2 If an existing NID is accessed, it shall be capable of transferring electrical analog or digital signals between the end user's customer premises and the Distribution Media and/or cross connect to Heritage's NID.
- 2.7.3.3 Existing BellSouth NIDS will be provided in "as is" condition. Heritage may request BellSouth do additional work to the NID on a time and material basis. When Heritage deploys its own local loops with respect to multiple-line termination devices, Heritage shall specify the quantity of NIDs connections that it requires within such device.
- 2.8 **Sub-loop Elements**
- 2.8.1 Where facilities permit, BellSouth shall offer access to its Unbundled Sub Loop (USL) and Unbundled Sub-loop Concentration (USLC) System.
- 2.8.2 **Unbundled Sub-Loop Distribution**
- 2.8.2.1 The unbundled sub-loop distribution facility is a dedicated transmission facility that BellSouth provides from an end user's point of demarcation to a BellSouth cross-connect device. The BellSouth cross-connect device may be located within a remote terminal (RT) or a stand-alone cross-box in the field or in the equipment room of a building. The unbundled sub-loop distribution media is a copper twisted

pair that can be provisioned as a 2 Wire or 4 Wire facility. BellSouth will make the following available sub-loop distribution offerings where facilities permit:

- Unbundled Sub-Loop Distribution – Voice Grade
- Unbundled Copper Sub-Loop
- Unbundled Sub-Loop Distribution – Intrabuilding Network Cable (aka riser cable)

- 2.8.2.2 Unbundled Sub-Loop Distribution – Voice Grade (USLD-VG) is a sub-loop facility from the cross-box in the field up to and including the point of demarcation, at the end user's premises and may have load coils.
- 2.8.2.3 Unbundled Copper Sub-Loop (UCSL) is a copper facility of any length provided from the cross-box in the field up to and including the end-user's point of demarcation. If available, this facility will not have any intervening equipment such as load coils between the end-user and the cross-box.
- 2.8.2.4 If Heritage requests a UCSL and it is not available, Heritage may request the Sub-Loop facility be modified pursuant to the ULM process request to remove load coils and/or bridged taps. If load coils and/or bridged taps are removed, the facility will be classified as a UCSL.
- 2.8.2.5 Unbundled Sub-Loop Distribution – Intrabuilding Network Cable (USLD-INC) is the distribution facility inside a building or between buildings on the same continuous property which is not separated by a public street or road. USLD-INC includes the facility from the cross-connect device in the building equipment room up to and including the point of demarcation, at the end user's premises.
- 2.8.2.6 BellSouth will install a cross connect panel in the building equipment room for the purpose of accessing USLD-INC pairs from a building equipment room. The cross-connect panel will function as a single point of interconnection (SPOI) for USLD-INC and will be accessible by multiple carriers as space permits. BellSouth will place cross-connect blocks in 25-pair increments for Heritage's use on this cross-connect panel. Heritage will be responsible for connecting its facilities to the 25-pair cross-connect block(s).
- 2.8.2.7 Unbundled Sub-Loop distribution facilities shall support functions associated with provisioning, maintenance and testing of the Unbundled Sub-Loop. For access to Voice Grade USLD and UCSL, Heritage shall install a cable to the BellSouth cross-box pursuant to the terms and conditions for physical collocation for remote sites set forth in this Agreement. This cable would be connected by a BellSouth technician within the BellSouth cross-box during the set-up process. Heritage's cable pairs can then be connected to BellSouth's USL within the BellSouth cross-box by the BellSouth technician.
- 2.8.2.8 Through the Service Inquiry (SI) process, BellSouth will determine whether access to Unbundled Sub-Loops at the location requested by Heritage is technically

feasible and whether sufficient capacity exists in the cross-box. If existing capacity is sufficient to meet Heritage's request, then BellSouth will perform the site set-up as described in Section 2.8.2.9. If any work must be done to modify existing BellSouth facilities or add new facilities (other than adding the cross-connect panel in a building equipment room as noted in Section 2.8.2.9) to accommodate Heritage's request for Unbundled Sub-Loops, Heritage may request BellSouth's Special Construction (SC) process to determine additional costs required to provision the Unbundled Sub-Loops. Heritage will have the option to proceed under the SC process to modify the BellSouth facilities.

2.8.2.9 The site set-up must be completed before Heritage can order sub-loop pairs. For the site set-up in a BellSouth cross-connect box in the field, BellSouth will perform the necessary work to splice Heritage's cable into the cross-connect box. For the site set-up inside a building equipment room, BellSouth will perform the necessary work to install the cross-connect panel and the connecting block(s) that will be used to provide access to the requested USLs.

2.8.2.10 Once the site set-up is complete, Heritage will request sub-loop pairs through submission of a Local Service Request (LSR) form to the Local Carrier Service Center (LCSC). Order Coordination is required with USL pair provisioning when Heritage requests reuse of an existing facility and is in addition to the USL pair rate. For expedite requests by Heritage for sub-loop pairs, expedite charges will apply for intervals less than 5 days.

2.8.2.11 Unbundled Sub-Loops will be provided in accordance with technical reference TR73600.

2.8.3 **Unbundled Network Terminating Wire (UNTW)**

2.8.3.1 Unbundled Network Terminating Wire (UNTW) is unshielded twisted copper wiring that is used to extend circuits from an intra-building network cable terminal or from a building entrance terminal to an individual customer's point of demarcation. It is the final portion of the Loop which, in multi-subscriber configurations, represents the point at which the network branches out to serve individual subscribers.

2.8.3.2 This element will be provided in Multi-Dwelling Units (MDUs) and/or Multi-Tenants Units (MTUs) where BellSouth owns wiring all the way to the end-users premises. BellSouth will not provide this element in those locations where the property owner provides its own wiring to the end-user's premises, where a third party owns the wiring to the end-user's premises or where the property owner will not allow BellSouth to place its facilities to the end user.

2.8.3.3 Requirements

- 2.8.3.3.1 On a multi-unit premises, upon request of the other Party ("Requesting Party"), the Party owning the network terminating wire will provide access to UNTW pairs on an Access Terminal that is suitable for use by multiple carriers at each Garden Terminal or Wiring Closet.
- 2.8.3.3.2 The Provisioning Party shall not be required to install new or additional NTW beyond existing NTW to provision the services of the Requesting Party.
- 2.8.3.3.3 Upon receipt of the UNTW Service Inquiry (SI) requesting access to the Provisioning Party's UNTW pairs at a multi-unit premises, representatives of both Parties will participate in a meeting at the site of the requested access. The purpose of the site visit will include discussion of the procedures for installation and location of the Access Terminals. By request of the Requesting Party, an Access Terminal will be installed either adjacent to each Provisioning Party's Garden Terminal or inside each Wiring Closet. Requesting Party will deliver and connect its central office facilities to the UNTW pairs within the Access Terminal. Requesting Party may access any available pair on an Access Terminal. A pair is available when a pair is not being utilized to provide service or where the end user has requested a change in its local service provider to the Requesting Party. Prior to connecting Requesting Party's service on a pair previously used by Provisioning Party, Requesting Party is responsible for ensuring the end-user is no longer using Provisioning Party's service or another CLEC's service before accessing UNTW pairs.
- 2.8.3.3.4 Access Terminal installation intervals will be established on an individual case basis.
- 2.8.3.3.5 Requesting Party is responsible for obtaining the property owner's permission for Provisioning Party to install an Access Terminal(s) on behalf of the Requesting Party. The submission of the SI by the Requesting Party will serve as certification by the Requesting Party that such permission has been obtained. If the property owner objects to Access Terminal installations that are in progress or subsequent to completion and demands removal of Access Terminals, Requesting Party will be responsible for costs associated with removing Access Terminals and restoring property to its original state prior to Access Terminals being installed.
- 2.8.3.3.6 The Requesting Party shall indemnify and hold harmless the Provisioning Party against any claims of any kind that may arise out of the Requesting Party's failure to obtain the property owner's permission. Requesting Party will be billed for non-recurring and recurring charges for accessing UNTW pairs at the time the Requesting Party activates the pair(s). The Requesting Party will notify the Provisioning Party each time it activates UNTW pairs using the LSR form.
- 2.8.3.3.7 Requesting Party will isolate and report troubles in the manner specified by the Provisioning Party. Requesting Party must tag the UNTW pair that requires repair. If Provisioning Party dispatches a technician on a reported trouble call and

no UNTW trouble is found, Provisioning Party will charge Requesting Party for time spent on the dispatch and testing the UNTW pair(s).

- 2.8.3.3.8 If Requesting Party initiates the Access Terminal installation and the Requesting Party has not activated at least one pair on the Access Terminal installed pursuant to Requesting Party's request for an Access Terminal within 6 months of installation of the Access Terminal, Provisioning Party will bill Requesting Party a non-recurring charge equal to the actual cost of provisioning the Access Terminal.
- 2.8.3.3.9 If Provisioning Party determines that Requesting Party is using the UNTW pairs without reporting the activation of the pairs, the following charges shall apply:
- 2.8.3.3.9.1 If Requesting Party issued a LSR to disconnect an end-user from Provisioning Party in order to use a UNTW pair, Requesting Party will be billed for the use of the pair back to the disconnect order date.
- 2.8.3.3.9.2 If Requesting Party activated a UNTW pair on which Provisioning Party was not previously providing service, Requesting Party will be billed for the use of that pair back to the date the end-user began receiving service using that pair. Upon request, Requesting Party will provide copies of its billing record to substantiate such date. If Requesting Party fails to provide such records, then Provisioning Party will bill the Requesting Party back to the date of the Access Terminal installation.
- 2.8.4 **Unbundled Sub-Loop Feeder**
- 2.8.4.1 Unbundled Sub-Loop Feeder (USLF) provides connectivity between BellSouth's central office and cross-box (or other access point) that serves an end user location.
- 2.8.4.2 USLF utilized for voice traffic can be configured as 2-wire voice (USLF-2W/V) or 4-wire voice (USLF-4W/V).
- 2.8.4.3 USLF utilized for digital traffic can be configured as 2-wire ISDN (USLF-2W/I); 2-wire Copper (USLF-2W/C); 4-wire Copper (USLF-4W/C); 4-wire DS0 level loop (USLF-4W/D0); or 4-wire DS1 and ISDN (USLF-4W/DI).
- 2.8.4.4 USLF will provide access to both the equipment and the features in the BellSouth central office and BellSouth cross box necessary to provide a 2W or 4W communications pathway from the BellSouth central office to the BellSouth cross-box. This element will allow for the connection of Heritage's loop distribution elements onto BellSouth's feeder system.
- 2.8.4.5 **Requirements**
- 2.8.4.5.1 Heritage will extend a compatible cable to BellSouth's cross-box. BellSouth will connect the cable to a panel inside the BellSouth cross-box to the requested level

of feeder element. In those cases when there is no room in the BellSouth cross-box to accommodate the additional cross-connect panels mentioned above, BellSouth will utilize its Special Construction process to determine the costs to provide the sub-loop feeder element to Heritage. Heritage will then have the option of paying the special construction charges or canceling the order.

2.8.4.5.2 USLF will be a designed circuit and BellSouth will provide a Design Layout Record (DLR) for this element.

2.8.4.5.3 BellSouth will provide USLF elements in accordance with applicable industry standards for these types of facilities. Where industry standards do not exist, BellSouth's TR73600 will be used to determine performance parameters.

2.8.5 **Unbundled Loop Concentration (ULC)**

2.8.5.1 BellSouth will provide to Heritage Unbundled Loop Concentration (ULC). Loop concentration systems in the central office concentrate the signals transmitted over local loops onto a digital loop carrier system. The concentration device is placed inside a BellSouth central office. BellSouth will offer ULC with a TR008 interface or a TR303 interface.

2.8.5.2 ULC will be offered in two system options. System A will allow up to 96 BellSouth loops to be concentrated onto two or more DS1s. The high-speed connection from the concentrator will be at the electrical DS1 level and will connect to Heritage at Heritage's collocation site. System B will allow up to 192 BellSouth loops to be concentrated onto 4 or more DS1s. System A may be upgraded to a System B. A minimum of two DS1s is required for each system (i.e., System A requires two DS1s and System B would require an additional two DS1s or four in total). All DS1 interfaces will terminate to Heritage's collocation space. ULC service is offered with concentration (2 DS1s for 96 channels) or without concentration (4 DS1s for 96 channels) and with or without protection. A Loop Interface element will be required for each loop that is terminated onto the ULC system.

2.8.6 **Unbundled Sub-Loop Concentration (USLC)**

2.8.6.1 Where facilities permit, Heritage may concentrate its sub-loops onto multiple DS1s back to the BellSouth Central Office.

2.8.6.2 USLC, using the Lucent Series 5 equipment, will be offered in two system options. System A will allow up to 96 of Heritage's sub-loops to be concentrated onto two or more DS1s; System B will allow an additional 96 of Heritage's sub-loops to be concentrated onto two or more additional DS1s. One System A may be supplemented with one System B and they both must be physically located in a single Series 5 dual channel bank. A minimum of two DS1s is required for each system (i.e., System A requires two DS1s and System B would require an

additional two DS1s or four in total). The DS1 level facility that connects the Remote Terminal site with the serving wire center is known as a Feeder Interface. All DS1 Feeder Interfaces will terminate to Heritage's demarcation point associated with Heritage's collocation space within the SWC that serves the remote terminal (RT). USLC service is offered with or without concentration and with or without a protection DS1.

2.8.6.3 Heritage is required to deliver its sub-loops to its own cross-box, RT, or other similar device and deliver a single cable to the BellSouth RT. This cable shall be connected, by a BellSouth technician, to a cross-connect panel within the BellSouth RT/cross-box and shall allow Heritage's sub-loops to be placed on the USLC and transported to Heritage's collocation space at a DS1 level.

2.8.7 **Dark Fiber Loop**

2.8.7.1 Dark Fiber Loop is an unused optical transmission facility without attached signal regeneration, multiplexing, aggregation or other electronics that connects two points within BellSouth's network. Dark Fiber Loops may be strands of optical fiber existing in aerial or underground structure. BellSouth will not provide line terminating elements, regeneration or other electronics necessary for Heritage to utilize Dark Fiber Loops.

2.8.7.2 A Dark Fiber Loop is a point to point arrangement from an end user's premises connected via a cross connect to the demarcation point associated with Heritage's collocation space in the end user's serving wire center.

2.8.7.3 Dark Fiber Loop rates are differentiated between Local Channel, Interoffice Channel and Local Loop.

2.8.7.4 **Requirements**

2.8.7.4.1 BellSouth shall make available Dark Fiber Loop where it exists in BellSouth's network and where, as a result of future building or deployment, it becomes available. Dark Fiber Loop will not be deemed available if: (1) it is used by BellSouth for maintenance and repair purposes; (2) it is designated for use pursuant to a firm order placed by another customer; (3) it is restricted for use by all carriers, including BellSouth, because of transmission problems or because it is scheduled for removal due to documented changes to roads and infrastructure; or (4) BellSouth has plans to use the fiber within a two-year planning period. BellSouth is not required to place the fiber for Dark Fiber Loop if none is available.

2.8.7.4.2 If the requested Dark Fiber Loop has any lightwave repeater equipment interspliced to it, BellSouth will remove such equipment at Heritage's request subject to time and materials charges.

- 2.8.7.4.3 Heritage is solely responsible for testing the quality of the Dark Fiber to determine its usability and performance specifications.
- 2.8.7.4.4 BellSouth shall use its commercially reasonable efforts to provide to Heritage information regarding the location, availability and performance of Dark Fiber Loop within ten (10) business days after receiving a Service Inquiry (“SI”) from Heritage.
- 2.8.7.4.5 If the requested Dark Fiber Loop is available, BellSouth shall use commercially reasonable efforts to provision the Dark Fiber Loop to Heritage within twenty (20) business days after Heritage submits a valid, error free LSR. Provisioning includes identification of appropriate connection points (e.g., Light Guide Interconnection (LGX) or splice points) to enable Heritage to connect or splice Heritage provided transmission media (e.g., optical fiber) or equipment to the Dark Fiber Loop.
- 2.8.7.4.6 Heritage may splice at the end points and test Dark Fiber Loop obtained from BellSouth using Heritage or Heritage designated personnel. BellSouth shall provide appropriate interfaces to allow splicing and testing of Dark Fiber Loop. For fiber in underground conduit, BellSouth shall provide a minimum of 25 feet of excess cable to allow the uncoiled fiber to reach from the manhole to a splicing van.

2.9 **Loop Makeup (LMU)**

2.9.1 Description of Service

- 2.9.1.1 BellSouth shall make available to Heritage (LMU) information so that Heritage can make an independent judgment about whether the Loop is capable of supporting the advanced services equipment Heritage intends to install and the services Heritage wishes to provide. This section addresses LMU as a *preordering* transaction, distinct from Heritage ordering any other service(s). Loop Makeup *Service Inquiries (LMUSI) for preordering loop makeup* are likewise unique from other preordering functions with associated service inquiries (SI) as described in this Agreement.
- 2.9.1.2 BellSouth will provide Heritage LMU information consisting of the composition of the loop material (copper/fiber); the existence, location and type of equipment on the Loop, including but not limited to digital loop carrier or other remote concentration devices, feeder/distribution interfaces, bridged taps, load coils, pair-gain devices; the loop length; the wire gauge and electrical parameters.
- 2.9.1.3 BellSouth’s LMU information is provided to Heritage as it exists either in BellSouth’s databases or in its hard copy facility records. BellSouth does not guarantee accuracy or reliability of the LMU information provided.
- 2.9.1.4 Heritage may choose to use equipment that it deems will enable it to provide a certain type and level of service over a particular BellSouth Loop. The

determination shall be made solely by Heritage and BellSouth shall not be liable in any way for the performance of the advanced data services provisioned over said Loop. The specific Loop type (ADSL, HDSL, or otherwise) ordered on the LSR must match the LMU of the loop reserved taking into consideration any requisite line conditioning. The LMU data is provided for informational purposes only and does not guarantee Heritage's ability to provide advanced data services over the ordered loop type. Further, if Heritage orders loops that are not intended to support advanced services (such as UV-SL1, UV-SL2, or ISDN compatible loops) and that are not inventoried as advanced services loops, the LMU information for such loops is subject to change at any time due to modifications and/or upgrades to BellSouth's network. Heritage is fully responsible for any of its service configurations that may differ from BellSouth's technical standard for the loop type ordered.

2.9.2 Submitting Loop Makeup Service Inquiries

2.9.2.1 Heritage may obtain LMU information by submitting a LMU Service Inquiry (LMUSI) mechanically or manually. Mechanized LMUSIs should be submitted through BellSouth's Operational Support Systems interfaces. After obtaining the Loop information from the mechanized LMUSI process, if Heritage needs further loop information in order to determine loop service capability, Heritage may initiate a separate Manual Service Inquiry for a separate nonrecurring charge as set forth in Exhibit B of this Attachment.

2.9.2.2 Manual LMUSIs shall be submitted by electronic mail to BellSouth's Complex Resale Support Group (CRSG)/Account Team utilizing the Preordering Loop Makeup Service Inquiry form. The service interval for the return of a Loop Makeup Manual Service Inquiry is three business days. Manual LMUSIs are not subject to expedite requests. This service interval is distinct from the interval applied to the subsequent service order.

2.9.3 Loop Reservations

2.9.3.1 For a Mechanized LMUSI, Heritage may reserve up to ten Loop facilities. For a Manual LMUSI, Heritage may reserve up to three Loop facilities.

2.9.3.2 Heritage may reserve facilities for up to four (4) business days for each facility requested on a LMUSI from the time the LMU information is returned to Heritage. During and prior to Heritage placing an LSR, the reserved facilities are rendered unavailable to other customers, including BellSouth. If Heritage does not submit an LSR for a UNE service on a reserved facility within the four-day reservation timeframe, the reservation of that spare facility will become invalid and the facility will be released.

2.9.3.3 Charges for preordering LMUSI are separate from any charges associated with ordering other services from BellSouth.

2.9.4 **Ordering of Other UNE Services**

2.9.4.1 All LSRs issued for reserved facilities shall reference the facility reservation number as provided by BellSouth. Heritage will not be billed any additional LMU charges for the loop ordered on such LSR. If, however, Heritage does not reserve facilities upon an initial LMUSI, Heritage's placement of an order for an advanced data service type facility will incur the appropriate billing charges to include service inquiry and reservation per Exhibit B of this Attachment.

2.9.4.2 Where Heritage has reserved multiple Loop facilities on a single reservation, Heritage may not specify which facility shall be provisioned when submitting the LSR. For those occasions, BellSouth will assign to Heritage, subject to availability, a facility that meets the BellSouth technical standards of the BellSouth type Loop as ordered by Heritage. If the ordered Loop type is not available, Heritage may utilize the Unbundled Loop Modification process or the Special Construction process, as applicable, to obtain the Loop type ordered.

3. **High Frequency Spectrum Network Element**

3.1 **General**

3.1.1 BellSouth shall provide Heritage access to the high frequency portion of the local loop as an unbundled network element only where BellSouth is the voice service provider to the end user ("High Frequency Spectrum") at the rates set forth in this Attachment.

3.1.2 The High Frequency Spectrum is defined as the frequency range above the voiceband on a copper loop facility carrying analog circuit-switched voiceband transmissions. Access to the High Frequency Spectrum is intended to allow Heritage the ability to provide Digital Subscriber Line ("xDSL") data services to the end user for which BellSouth provides voice services. The High Frequency Spectrum shall be available for any version of xDSL complying with Spectrum Management Class 5 of ANSI T1.417, *American National Standard for Telecommunications, Spectrum Management for Loop Transmission Systems*. BellSouth will continue to have access to the low frequency portion of the loop spectrum (from 300 Hertz to at least 3000 Hertz, and potentially up to 3400 Hertz, depending on equipment and facilities) for the purposes of providing voice service. Heritage shall only use xDSL technology that is within the PSD mask for Spectrum Management Class 5 as found in the above-mentioned document.

3.1.3 Access to the High Frequency Spectrum requires an unconditioned, 2-wire copper Loop. An unloaded Loop is a copper Loop with no load coils, low-pass filters, range extenders, DAMLs, or similar devices and minimal bridged taps consistent with ANSI T1.413 and T1.601. BellSouth will provide Loop conditioning to Heritage in accordance with the Unbundled Loop Modification process set forth in Section 2.5 of this Attachment. BellSouth is not required to condition a Loop for

access to the High Frequency spectrum if conditioning of that Loop significantly degrades BellSouth's voice service. If Heritage requests that BellSouth condition a Loop longer than 18,000 ft. and such conditioning significantly degrades the voice services on the Loop, Heritage shall pay for the Loop to be restored to its original state.

3.2 Provisioning of High Frequency Spectrum and Splitter Space

3.2.1 BellSouth will provide Heritage with access to the High Frequency Spectrum as follows:

3.2.1.1 To order High Frequency Spectrum on a particular Loop, Heritage must have a Digital Subscriber Line Access Multiplexer (DSLAM) collocated in the central office that serves the end-user of such Loop. Heritage may order splitters in a central office once it has installed its DSLAM in that central office. BellSouth will install splitters within forty-two (42) calendar days of Heritage's submission of such order to the BellSouth Complex Resale Support Group; provided, however, that in the event BellSouth did not have reasonable notice that a particular central office was to have a splitter installed therein, the forty-two (42) day interval shall not apply. Collocation itself or an application for collocation will serve as reasonable notice.

3.2.1.2 Once a splitter is installed on behalf of Heritage in a central office in which Heritage is located, Heritage shall be entitled to order the High Frequency Spectrum on lines served out of that central office. BellSouth will bill and Heritage shall pay the electronic or manual ordering charges as applicable when Heritage orders High Frequency Spectrum for end-user service.

3.2.1.3 BellSouth will select, purchase, install, and maintain a central office POTS splitter and provide Heritage access to data ports on the splitter. The splitter will route the High Frequency Spectrum on the circuit to Heritage's xDSL equipment in Heritage's collocation space. At least 30 days before making a change in splitter suppliers, BellSouth will provide Heritage with a carrier notification letter, informing Heritage of change. Heritage shall purchase ports on the splitter in increments of 24 ports.

3.2.1.4 BellSouth will install the splitter in (i) a common area close to Heritage's collocation area, if possible; or (ii) in a BellSouth relay rack as close to Heritage's DS0 termination point as possible. Heritage shall have access to the splitter for test purposes, regardless of where the splitter is placed in the BellSouth premises. For purposes of this section, a common area is defined as an area in the central office in which both Parties have access to a common test access point. A Termination Point is defined as the point of termination for Heritage on the toll main distributing frame in the central office and is not the demarcation point set forth in Attachment 4 of this Agreement. BellSouth will cross-connect the splitter

data ports to a specified Heritage DS0 at such time that a Heritage end user's service is established.

- 3.2.1.5 The High Frequency Spectrum shall only be available on Loops on which BellSouth is also providing, and continues to provide, analog voice service directly to the end user. In the event the end-user terminates its BellSouth provided voice service for any reason, or in the event BellSouth disconnects the end user's voice service pursuant to its tariffs or applicable law, and Heritage desires to continue providing xDSL service on such Loop, Heritage shall be required to purchase a full stand-alone Loop unbundled network element. To the extent commercially practicable, BellSouth shall give Heritage notice in a reasonable time prior to disconnect, which notice shall give Heritage an adequate opportunity to notify BellSouth of its intent to purchase such Loop. In those cases in which BellSouth no longer provides voice service to the end user and Heritage purchases the full stand-alone Loop, Heritage may elect the type of loop it will purchase. Heritage will pay the appropriate recurring and non-recurring rates for such Loop as set forth in Exhibit B to this Attachment. In the event Heritage purchases a voice grade Loop, Heritage acknowledges that such Loop may not remain xDSL compatible.
- 3.2.1.6 Only one competitive local exchange carrier shall be permitted access to the High Frequency Spectrum of any particular loop.
- 3.2.2 **Ordering**
- 3.2.2.1 BellSouth will provide Heritage the Local Service Request ("LSR") format to be used when ordering the High Frequency Spectrum.
- 3.2.2.2 BellSouth will return a manual Firm Order Confirmation ("FOC") in no more than two (2) business days after receipt of a valid, error free manual LSR. When Heritage submits an electronic LSR for High Frequency Spectrum, BellSouth will return a FOC in four (4) hours ninety-five percent (95%) of the time, or, for orders that do not flow-through, in two (2) business days. BellSouth will provide Heritage with access to the High Frequency Spectrum at the following target intervals:
- 3.2.2.2.1 For 1-5 lines at the same address within three (3) business days from BellSouth's issuance of a FOC; 6-10 lines at same address within 5 business days from BellSouth's issuance of a FOC; and more than 10 lines at the same address is to be negotiated.
- 3.2.2.2.2 BellSouth will provide to Heritage BellSouth's Loop Qualification System that BellSouth uses to qualify loops for its own ADSL offering.

3.2.2.2.3 BellSouth will provide Heritage access to Preordering Loop Makeup (LMU), in accordance with the terms of this Agreement. BellSouth shall bill and Heritage shall pay the rates for such services, as described in Exhibit B.

3.2.2.2.4 BellSouth shall test the data portion of the loop to ensure the continuity of the wiring for Heritage's data.

3.2.3 **Maintenance and Repair**

3.2.3.1 Heritage shall have access for repair and maintenance purposes, to any loop for which it has access to the High Frequency Spectrum. Heritage may access the loop at the point where the combined voice and data signal exits the central office splitter.

3.2.3.2 BellSouth will be responsible for repairing voice services and the physical line between the network interface device at the customer's premises and the Termination Point. Heritage will be responsible for repairing data services. Each Party will be responsible for maintaining its own equipment.

3.2.3.3 Heritage shall inform its end users to direct data problems to Heritage, unless both voice and data services are impaired, in which event the end users should call BellSouth.

3.2.3.4 Once a Party has isolated a trouble to the other Party's portion of the loop, the Party isolating the trouble shall notify the end user that the trouble is on the other Party's portion of the Loop.

3.2.3.5 In the event Heritage's deployment of xDSL on the High Frequency Spectrum significantly degrades the performance of other advanced services or of BellSouth's voice service on the same loop, BellSouth shall notify Heritage and allow twenty-four (24) hours to cure the trouble. If Heritage fails to resolve the trouble, BellSouth may discontinue Heritage's access to the High Frequency Spectrum on such loop.

3.2.4 **Line Splitting.**

3.2.4.1 BellSouth will work cooperatively with CLECs to develop rates, methods and procedures to operationalize a process whereby two CLECs, one being a provider of voice services (a "Voice CLEC") and the other being a provider of data services (a "Data CLEC") may provide services over the same loop. The loop and port over which the services are provided cannot be a loop and port combination (i.e., UNE-P), but must be individual, stand alone network elements. The Voice CLEC or the Data CLEC shall be responsible for connecting the loop and port to a CLEC-owned splitter. BellSouth shall not own or maintain the splitter used for this purpose. When such rates, methods and procedures have been developed and operationalized, then at the request of Heritage, the Parties shall amend this Agreement to incorporate the same.

4. Local Switching

4.1 BellSouth shall provide non-discriminatory access to local circuit switching capability and local tandem switching capability on an unbundled basis, except as set forth in the Sections below to Heritage for the provision of a telecommunications service. BellSouth shall provide non-discriminatory access to packet switching capability on an unbundled basis to Heritage for the provision of a telecommunications service only in the limited circumstance described below in Section 4.5.

4.2 **Local Circuit Switching Capability, including Tandem Switching Capability**

4.2.1 Local circuit switching capability is defined as: (A) line-side facilities, which include, but are not limited to, the connection between a loop termination at a main distribution frame and a switch line card; (B) trunk-side facilities, which include, but are not limited to, the connection between trunk termination at a trunk-side cross-connect panel and a switch trunk card; (C) switching provided by remote switching modules; and (D) all features, functions, and capabilities of the switch, which include, but are not limited to: (1) the basic switching function of connecting lines to lines, line to trunks, trunks to lines, and trunks to trunks, as well as the same basic capabilities made available to BellSouth's customers, such as a telephone number, white page listings, and dial tone; and (2) all other features that the switch is capable of providing, including but not limited to customer calling, customer local area signaling service features, and Centrex, as well as any technically feasible customized routing functions provided by the switch. Any features that are not currently available but are technically feasible through the switch can be requested through the BFR/NBR process.

4.2.2 Notwithstanding BellSouth's general duty to unbundle local circuit switching, BellSouth shall not be required to unbundle local circuit switching for Heritage when Heritage serves an end-user with four (4) or more voice-grade (DS-0) equivalents or lines served by BellSouth in one of the following MSAs: Atlanta, GA; Miami, FL; Orlando, FL; Ft. Lauderdale, FL; Charlotte-Gastonia-Rock Hill, NC; Greensboro-Winston Salem-High Point, NC; Nashville, TN; and New Orleans, LA, and BellSouth has provided non-discriminatory cost based access to the Enhanced Extended Link (EEL) throughout Density Zone 1 as determined by NECA Tariff No. 4 as in effect on January 1, 1999.

4.2.3 In the event that Heritage orders local circuit switching for an end user with four (4) or more 2-wire voice-grade loops from a BellSouth central office in an MSA listed above, BellSouth shall charge Heritage the market based rates in Exhibit B for use of the local circuit switching functionality for the affected facilities.

4.2.4 Unbundled Local Switching consists of three separate unbundled elements: Unbundled Ports, End Office Switching Functionality, and End Office Interoffice Trunk Ports.

- 4.2.5 Unbundled Local Switching combined with Common Transport and, if necessary, Tandem Switching provides to Heritage's end user local calling and the ability to presubscribe to a primary carrier for intraLATA and/or to presubscribe to a primary carrier for interLATA toll service.
- 4.2.6 Provided that Heritage purchases unbundled local switching from BellSouth and uses the BellSouth CIC for its end users' LPIC or if a BellSouth local end user selects BellSouth as its LPIC, then the Parties will consider as local any calls originated by an Heritage local end user, or originated by a BellSouth local end user and terminated to an Heritage local end user, where such calls originate and terminate in the same LATA, except for those calls originated and terminated through switched access arrangements (i.e., calls that are transported by a party other than BellSouth). For such calls, BellSouth will charge Heritage the UNE elements for the BellSouth facilities utilized. Neither Party shall bill the other originating or terminating switched access charges for such calls. Intercarrier compensation for local calls between BellSouth and Heritage shall be as described in BellSouth's UNE Local Call Flows set forth on BellSouth's web site.
- 4.2.7 BellSouth shall assess Heritage retroactive charges for UNE transport and switching associated with using the BellSouth LPIC if Heritage has been able to previously select BellSouth as the end user LPIC prior to the option allowing the selection of a BellSouth provided LATA-wide local calling area being offered.
- 4.2.8 Where Heritage purchases unbundled local switching from BellSouth but does not use the BellSouth CIC for its end users' LPIC, BellSouth will consider as local those direct dialed telephone calls that originate from an Heritage end user and terminate within the basic local calling area or within the extended local calling areas and that are dialed using 7 or 10 digits as defined and specified in Section A3 of BellSouth's General Subscriber Services Tariffs. For such local calls, BellSouth will charge Heritage the UNE elements for the BellSouth facilities utilized. Intercarrier compensation for local calls between BellSouth and Heritage shall be as described in BellSouth's UNE Local Call Flows set forth on BellSouth's web site.
- 4.2.9 For any calls that originate and terminate through switched access arrangements (i.e., calls that are transported by a party other than BellSouth), BellSouth shall bill Heritage the UNE elements for the BellSouth facilities utilized. Each Party may bill the toll provider originating or terminating switched access charges, as appropriate.
- 4.2.10 Reverse-billed toll calls, such as intraLATA 800 calls, calling card calls and third party billed calls, where BellSouth is the carrier shall also be considered as local calls and Heritage shall not bill BellSouth originating or terminating switched access for such calls.

4.2.11 **Unbundled Port Features**

- 4.2.11.1 Charges for Unbundled Port are as set forth in Exhibit B, and as specified in such exhibit, may or may not include individual features.
- 4.2.11.2 Where applicable and available, non-switch-based services may be ordered with the Unbundled Port at BellSouth's retail rates.
- 4.2.11.3 Any features that are not currently available but are technically feasible through the switch can be requested through the BFR/NBR process.
- 4.2.11.4 BellSouth will provide to Heritage selective routing of calls to a requested Operator System platform pursuant to Section 10 of Attachment 2. Any other routing requests by Heritage will be made pursuant to the BFR/NBR Process as set forth in General Terms and Conditions.

4.2.12 **Provision for Local Switching**

- 4.2.12.1 BellSouth shall perform routine testing (e.g., Mechanized Loop Tests (MLT) and test calls such as 105, 107 and 108 type calls) and fault isolation on a mutually agreed upon schedule.
- 4.2.12.2 BellSouth shall control congestion points such as those caused by radio station call-ins, and network routing abnormalities. All traffic shall be restricted in a non-discriminatory manner.
- 4.2.12.3 BellSouth shall perform manual call trace and permit customer originated call trace. BellSouth shall provide Switching Service Point (SSP) capabilities and signaling software to interconnect the signaling links destined to the Signaling Transfer Point Switch (STPS). These capabilities shall adhere to the technical specifications set forth in the applicable industry standard technical references.
- 4.2.12.4 BellSouth shall provide interfaces to adjuncts through Telcordia standard interfaces. These adjuncts can include, but are not limited to, the Service Circuit Node and Automatic Call Distributors. BellSouth shall offer to Heritage all AIN triggers in connection with its SMS/SCE offering.
- 4.2.12.5 BellSouth shall provide access to SS7 Signaling Network or Multi-Frequency trunking if requested by Heritage.

4.2.13 **Local Switching Interfaces**

- 4.2.13.1 Heritage shall order ports and associated interfaces compatible with the services it wishes to provide, as listed in Exhibit B. BellSouth shall provide the following local switching interfaces:

- 4.2.13.1.1 Standard Tip/Ring interface including loopstart or groundstart, on-hook signaling (e.g., for calling number, calling name and message waiting lamp);
- 4.2.13.1.2 Coin phone signaling;
- 4.2.13.1.3 Basic Rate Interface ISDN adhering to appropriate Telcordia Technical Requirements;
- 4.2.13.1.4 Two-wire analog interface to PBX;
- 4.2.13.1.5 Four-wire analog interface to PBX;
- 4.2.13.1.6 Four-wire DS1 interface to PBX or customer provided equipment (e.g. computers and voice response systems);
- 4.2.13.1.7 Primary Rate ISDN to PBX adhering to ANSI standards Q.931, Q.932 and appropriate Telcordia Technical Requirements;
- 4.2.13.1.8 Switched Fractional DS1 with capabilities to configure Nx64 channels (where N = 1 to 24); and
- 4.2.13.1.9 Loops adhering to Telcordia TR-NWT-08 and TR-NWT-303 specifications to interconnect Digital Loop Carriers.

4.3 **Tandem Switching**

4.3.1 The Tandem Switching capability Network Element is defined as: (i) trunk-connect facilities, which include, but are not limited to, the connection between trunk termination at a cross connect panel and switch trunk card; (ii) the basic switch trunk function of connecting trunks to trunks; and (iii) the functions that are centralized in the Tandem Switches (as distinguished from separate end office switches), including but not limited to call recording, the routing of calls to operator services and signaling conversion features.

4.3.2 **Technical Requirements**

4.3.2.1 Tandem Switching shall have the same capabilities or equivalent capabilities as those described in Telcordia TR-TSY-000540 Issue 2R2, Tandem Supplement, 6/1/90. The requirements for Tandem Switching include, but are not limited to the following:

4.3.2.1.1 Tandem Switching shall provide signaling to establish a tandem connection;

4.3.2.1.2 Tandem Switching will provide screening as jointly agreed to by Heritage and BellSouth;

- 4.3.2.1.3 Tandem Switching shall provide Advanced Intelligent Network triggers supporting AIN features where such routing is not available from the originating end office switch, to the extent such Tandem switch has such capability;
- 4.3.2.1.4 Tandem Switching shall provide access to Toll Free number database;
- 4.3.2.1.5 Tandem Switching shall provide connectivity to PSAPs where 911 solutions are deployed and the tandem is used for 911; and
- 4.3.2.1.6 Where appropriate, Tandem Switching shall provide connectivity for the purpose of routing transit traffic to and from other carriers.
- 4.3.2.2 BellSouth may perform testing and fault isolation on the underlying switch that is providing Tandem Switching. Such testing shall be testing routinely performed by BellSouth. The results and reports of the testing shall be made available to Heritage.
- 4.3.2.3 BellSouth shall control congestion points and network abnormalities. All traffic will be restricted in a non-discriminatory manner.
- 4.3.2.4 Tandem Switching shall process originating toll-free traffic received from Heritage's local switch.
- 4.3.2.5 In support of AIN triggers and features, Tandem Switching shall provide SSP capabilities when these capabilities are not available from the Local Switching Network Element, to the extent such Tandem Switch has such capability.
- 4.3.3 Upon Heritage's purchase of overflow trunk groups, Tandem Switching shall provide an alternate routing pattern for Heritage's traffic overflowing from direct end office high usage trunk groups.
- 4.4 **AIN Selective Carrier Routing for Operator Services, Directory Assistance and Repair Centers**
- 4.4.1 BellSouth will provide AIN Selective Carrier Routing at the request of Heritage. AIN Selective Carrier Routing will provide Heritage with the capability of routing operator calls, 0+ and 0- and 0+ NPA (LNPA) 555-1212 directory assistance, 1+411 directory assistance and 611 repair center calls to pre-selected destinations.
- 4.4.2 Heritage shall order AIN Selective Carrier Routing through its Account Team. AIN Selective Carrier Routing must first be established regionally and then on a per central office, per state basis.
- 4.4.3 AIN Selective Carrier Routing is not available in DMS 10 switches.
- 4.4.4 Where AIN Selective Carrier Routing is utilized by Heritage, the routing of Heritage's end user calls shall be pursuant to information provided by Heritage and

stored in BellSouth's AIN Selective Carrier Routing Service Control Point database. AIN Selective Carrier Routing shall utilize a set of Line Class Codes (LCCs) unique to a basic class of service assigned on an 'as needed' basis. The same LCCs will be assigned in each central office where AIN Selective Carrier Routing is established.

- 4.4.5 Upon ordering of AIN Selective Carrier Routing Regional Service, Heritage shall remit to BellSouth the Regional Service Order non-recurring charges set forth in Exhibit B of this Attachment. There shall be a non-recurring End Office Establishment Charge per office due at the addition of each central office where AIN Selective Carrier Routing will be utilized. Said non-recurring charge shall be as set forth in Exhibit B of this Attachment. For each Heritage end user activated, there shall be a non-recurring End User Establishment charge as set forth in Exhibit B of this Attachment. Heritage shall pay the AIN Selective Carrier Routing Per Query Charge set forth in Exhibit B of this Attachment.
- 4.4.6 This Regional Service Order non-recurring charge will be non-refundable and will be paid with 1/2 due up-front with the submission of all fully completed required forms, including: Regional Selective Carrier Routing (SCR) Order Request-Form A, Central Office AIN Selective Carrier Routing (SCR) Order Request - Form B, AIN_SCR Central Office Identification Form - Form C, AIN_SCR Routing Options Selection Form - Form D, and Routing Combinations Table - Form E. BellSouth has 30 days to respond to Heritage's fully completed firm order as a Regional Service Order. With the delivery of this firm order response to Heritage, BellSouth considers that the delivery schedule of this service commences. The remaining 1/2 of the Regional Service Order payment must be paid when at least 90% of the Central Offices listed on the original order have been turned up for the service.
- 4.4.7 The non-recurring End Office Establishment Charge will be billed to Heritage following BellSouth's normal monthly billing cycle for this type of order.
- 4.4.8 End-User Establishment Orders will not be turned-up until the second payment is received for the Regional Service Order. The non-recurring End-User Establishment Charges will be billed to Heritage following BellSouth's normal monthly billing cycle for this type of order.
- 4.4.9 Additionally, the AIN Selective Carrier Routing Per Query Charge will be billed to Heritage following the normal billing cycle for per query charges.
- 4.4.10 All other network components needed, for example, unbundled switching and unbundled local transport, etc, will be billed per contracted rates.
- 4.5 **Packet Switching Capability**

- 4.5.1 The packet switching capability network element is defined as the function of routing or forwarding packets, frames, cells or other data units based on address or other routing information contained in the packets, frames, cells or other data units.
- 4.5.2 BellSouth shall be required to provide non-discriminatory access to unbundled packet switching capability only where each of the following conditions are satisfied:
- 4.5.2.1 BellSouth has deployed digital loop carrier systems, including but not limited to, integrated digital loop carrier or universal digital loop carrier systems; or has deployed any other system in which fiber optic facilities replace copper facilities in the distribution section (e.g., end office to remote terminal, pedestal or environmentally controlled vault);
- 4.5.2.2 There are no spare copper loops capable of supporting the xDSL services Heritage seeks to offer;
- 4.5.2.3 BellSouth has not permitted Heritage to deploy a DSLAM at the remote terminal, pedestal or environmentally controlled vault or other interconnection point, nor has Heritage obtained a virtual collocation arrangement at these sub-loop interconnection points as defined by 47 CFR § 51.319 (b); and
- 4.5.2.4 BellSouth has deployed packet switching capability for its own use.
- 4.5.3 If there is a dispute as to whether BellSouth must provide Packet Switching, such dispute will be resolved according to the dispute resolution process set forth in Section 12 of the General Terms and Conditions of this Agreement, incorporated herein by this reference.
- 4.6 **Interoffice Transmission Facilities**
- 4.6.1 BellSouth shall provide nondiscriminatory access, in accordance with FCC Rule 51.311 and Section 251(c)(3) of the Act, to interoffice transmission facilities on an unbundled basis to Heritage for the provision of a telecommunications service.
5. **Unbundled Network Element Combinations**
- 5.1 Unbundled Network Element Combinations shall include: 1) Enhanced Extended Links (EELs); 2) Other Non-Switched Combinations; 3) UNE Loop/Special Access Combinations; and 4) UNE Loop/Port Combinations.
- 5.2 For purposes of this Section, references to "Currently Combined" network elements shall mean that such network elements are in fact already combined by BellSouth in the BellSouth network to provide service to a particular end user at a particular location.

5.3 **Enhanced Extended Links (EELs)**

5.3.1 Where facilities permit and where necessary to comply with an effective FCC and/or State Commission order, or as otherwise mutually agreed by the Parties, BellSouth shall offer access to loop and transport combinations, also known as the Enhanced Extended Link ("EEL") as defined in Section 5.3.2 below.

5.3.2 Subject to Section 5.3.3 below, BellSouth will provide access to the EEL in the combinations set forth in Section 5.3.4 following. Heritage shall provide to BellSouth a letter certifying that Heritage is providing a significant amount of local exchange service (as described in Sections 5.3.5.2, 5.3.5.3, 5.3.5.4, or 5.3.5.5) over such combinations. This offering is intended to provide connectivity from an end user's location through that end user's SWC to Heritage's POP serving wire center. The circuit must be connected to Heritage's switch for the purpose of provisioning telephone exchange service to Heritage's end-user customers. The EEL will be connected to Heritage's facilities in Heritage's collocation space at the POP SWC, or Heritage may purchase BellSouth's access facilities between Heritage's POP and Heritage's collocation space at the POP SWC.

5.3.3 BellSouth shall provide EEL combinations to Heritage in Georgia and Tennessee regardless of whether or not such EELs are Currently Combined. In all other states, BellSouth shall make available to Heritage those EEL combinations described in Section 5.3.4 below only to the extent such combinations are Currently Combined. Furthermore, BellSouth will make available new EEL combinations to Heritage in density Zone 1, as defined in 47 CFR 69.123 as of January 1, 1999, in the Atlanta, GA; Miami, FL; Orlando, FL; Ft. Lauderdale, FL; Charlotte-Gastonia-Rock Hill, NC; Greensboro-Winston Salem-High Point, NC; Nashville, TN; and New Orleans, LA, MSAs. Except as stated above, EELs will be provided to Heritage only to the extent such network elements are Currently Combined.

5.3.4 **EEL Combinations**

5.3.4.1 DS1 Interoffice Channel + DS1 Channelization + 2-wire VG Local Loop

5.3.4.2 DS1 Interoffice Channel + DS1 Channelization + 4-wire VG Local Loop

5.3.4.3 DS1 Interoffice Channel + DS1 Channelization + 2-wire ISDN Local Loop

5.3.4.4 DS1 Interoffice Channel + DS1 Channelization + 4-wire 56 kbps Local Loop

5.3.4.5 DS1 Interoffice Channel + DS1 Channelization + 4-wire 64 kbps Local Loop

5.3.4.6 DS1 Interoffice Channel + DS1 Local Loop

5.3.4.7 DS3 Interoffice Channel + DS3 Local Loop

- 5.3.4.8 STS-1 Interoffice Channel + STS-1 Local Loop
- 5.3.4.9 DS3 Interoffice Channel + DS3 Channelization + DS1 Local Loop
- 5.3.4.10 STS-1 Interoffice Channel + DS3 Channelization + DS1 Local Loop
- 5.3.4.11 2-wire VG Interoffice Channel + 2-wire VG Local Loop
- 5.3.4.12 4-wire VG Interoffice Channel + 4-wire VG Local Loop
- 5.3.4.13 4-wire 56 kbps Interoffice Channel + 4-wire 56 kbps Local Loop
- 5.3.4.14 4-wire 64 kbps Interoffice Channel + 4-wire 64 kbps Local Loop

5.3.5 **Special Access Service Conversions**

- 5.3.5.1 Heritage may not convert special access services to combinations of loop and transport network elements, whether or not Heritage self-provides its entrance facilities (or obtains entrance facilities from a third party), unless Heritage uses the combination to provide a significant amount of local exchange service, in addition to exchange access service, to a particular customer. To the extent Heritage requests to convert any special access services to combinations of loop and transport network elements at UNE prices, Heritage shall provide to BellSouth a letter certifying that Heritage is providing a significant amount of local exchange service (as described in this Section) over such combinations. The certification letter shall also indicate under what local usage option Heritage seeks to qualify for conversion of special access circuits. Heritage shall be deemed to be providing a significant amount of local exchange service over such combinations if one of the following options is met:
- 5.3.5.2 Heritage certifies that it is the exclusive provider of an end user's local exchange service. The loop-transport combinations must terminate at Heritage's collocation arrangement in at least one BellSouth central office. This option does not allow loop-transport combinations to be connected to BellSouth's tariffed services. Under this option, Heritage is the end user's only local service provider, and thus, is providing more than a significant amount of local exchange service. Heritage can then use the loop-transport combinations that serve the end user to carry any type of traffic, including using them to carry 100 percent interstate access traffic; or
- 5.3.5.3 Heritage certifies that it provides local exchange and exchange access service to the end user customer's premises and handles at least one third of the end user customer's local traffic measured as a percent of total end user customer local dialtone lines; and for DS1 circuits and above, at least 50 percent of the activated channels on the loop portion of the loop-transport combination have at least 5 percent local voice traffic individually, and the entire loop facility has at least 10 percent local voice traffic. When a loop-transport combination includes

multiplexing, each of the individual DS1 circuits must meet these criteria. The loop-transport combination must terminate at Heritage's collocation arrangement in at least one BellSouth central office. This option does not allow loop-transport combinations to be connected to BellSouth tariffed services; or

- 5.3.5.4 Heritage certifies that at least 50 percent of the activated channels on a circuit are used to provide originating and terminating local dialtone service and at least 50 percent of the traffic on each of these local dialtone channels is local voice traffic, and that the entire loop facility has at least 33 percent local voice traffic. When a loop-transport combination includes multiplexing, each of the individual DS1 circuits must meet these criteria. This option does not allow loop-transport combinations to be connected to BellSouth's tariffed services. Under this option, collocation is not required. Heritage does not need to provide a defined portion of the end user's local service, but the active channels on any loop-transport combination, and the entire facility, must carry the amount of local exchange traffic specified in this option.
- 5.3.5.5 In addition, there may be extraordinary circumstances where Heritage is providing a significant amount of local exchange service, but does not qualify under any of the three options set forth in Section 5.3.5. In such case, Heritage may petition the FCC for a waiver of the local usage options set forth in the June 2, 2000 Order. If a waiver is granted, then upon Heritage's request the Parties shall amend this Agreement to the extent necessary to incorporate the terms of such waiver for such extraordinary circumstance.
- 5.3.5.6 BellSouth may at its sole discretion audit Heritage records in order to verify the type of traffic being transmitted over combinations of loop and transport network elements. The audit shall be conducted by a third party independent auditor, and Heritage shall be given thirty days written notice of scheduled audit. Such audit shall occur no more than one time in a calendar year, unless results of an audit find noncompliance with the significant amount of local exchange service requirement. In the event of noncompliance, Heritage shall reimburse BellSouth for the cost of the audit. If, based on its audits, BellSouth concludes that Heritage is not providing a significant amount of local exchange traffic over the combinations of loop and transport network elements, BellSouth may file a complaint with the appropriate Commission, pursuant to the dispute resolution process as set forth in the Interconnection Agreement. In the event that BellSouth prevails, BellSouth may convert such combinations of loop and transport network elements to special access services and may seek appropriate retroactive reimbursement from Heritage.
- 5.3.5.7 ~~Heritage may~~ convert special access circuits to combinations of loop and transport UNEs pursuant to the terms of this Section and subject to the termination provisions in the applicable special access tariffs, if any.

5.3.6 **Rates**

5.3.6.1 Georgia and Tennessee

5.3.6.1.1 The non-recurring and recurring rates for the EEL Combinations of network elements set forth in 5.3.4, whether Currently Combined or new, are as set forth in Exhibit B of this Attachment.

5.3.6.1.2 For combinations of loop and transport network elements not set forth in Section 5.3.4, where the elements are not Currently Combined but are ordinarily combined in BellSouth's network, the non-recurring and recurring charges for such UNE combinations shall be the sum of the stand-alone non-recurring and recurring charges of the network elements which make up the combination.

5.3.6.1.3 To the extent that Heritage seeks to obtain other combinations of network elements that BellSouth ordinarily combines in its network which have not been specifically priced by the Commission when purchased in combined form, Heritage, at its option, can request that such rates be determined pursuant to the BFR/NBR process set forth in this Agreement.

5.3.6.2 All Other States

5.3.6.2.1 Subject to the preceding sections, for all other states, the non-recurring and recurring rates for the Currently Combined EEL combinations set forth in Section 5.3.4 and other Currently Combined network elements will be the sum of the recurring rates for the individual network elements plus a non recurring charge set forth in Exhibit B of this Attachment.

5.3.7 **Multiplexing**

5.3.7.1 Where multiplexing functionality is required in connection with loop and transport combinations, such multiplexing will be provided at the rates and on the terms set forth in this Agreement.

5.4 **Other Non-Switched Combinations**

5.4.1 In the states of Georgia and Tennessee, BellSouth shall make available to Heritage, in accordance with Section 5.4.2.1 below: (1) combinations of network elements other than EELs that are Currently Combined; and (2) combinations of network elements other than EELs that are not Currently Combined but that BellSouth ordinarily combines in its network. In all other states, BellSouth shall make available to Heritage, in accordance with Section 5.4.2.2 below, combinations of network elements other than EELs only to the extent such combinations are Currently Combined.

5.4.2 Rates

5.4.2.1 Georgia and Tennessee

- 5.4.2.1.1 The non-recurring and recurring rates for Other Network Element combinations, whether Currently Combined or new, are as set forth in Exhibit B of this Attachment.
- 5.4.2.1.2 For Other Network Element combinations where the elements are not Currently Combined but are ordinarily combined in BellSouth's network, the non-recurring and recurring charges for such UNE combinations shall be the sum of the stand-alone non-recurring and recurring charges of the network elements that make up the combination.
- 5.4.2.1.3 To the extent that Heritage seeks to obtain other combinations of network elements that BellSouth ordinarily combines in its network which have not been specifically priced by the Commission when purchased in combined form, Heritage, at its option, can request that such rates be determined pursuant to the BFR/NBR process set forth in this Agreement.
- 5.4.2.2 All Other States
 - 5.4.2.2.1 For all other states, the non-recurring and recurring rates for the Other Network Element Combinations that are Currently Combined will be the sum of the recurring rates for the individual network elements plus a non-recurring charge set forth in Exhibit B of this Attachment.
- 5.5 **UNE Loop/Special Access Combinations**
 - 5.5.1 BellSouth shall make available to Heritage a new combination of an unbundled loop and tariffed special access interoffice facilities. To the extent Heritage will require multiplexing functionality in connection with such combination, BellSouth will provide access to multiplexing within the central office pursuant to the terms, conditions and rates set forth in its Access Services Tariffs. The tariffed special access interoffice facilities and any associated tariffed services, including but not limited to multiplexing, shall not be eligible for conversion to UNEs as described in Section 5.3.5.
 - 5.5.2 Rates
 - 5.5.2.1 The non-recurring and recurring rates for UNE/Special Access Combinations will be the sum of the unbundled loop rates as set forth in Exhibit B and the interoffice transport rates and multiplexing rates as set forth in the Access Services Tariff.
- 5.6 **UNE Port/Loop Combinations**
 - 5.6.1 Combinations of port and loop unbundled network elements along with switching and transport unbundled network elements provide local exchange service for the origination or termination of calls. Port/ loop combinations support the same local calling and feature requirements as described in the Unbundled Local Switching or Port section of this Attachment 2 and the ability to presubscribe to a primary

carrier for intraLATA and/or to presubscribe to a primary carrier for interLATA toll service.

- 5.6.2 BellSouth shall make available Currently Combined and not Currently Combined UNE port/loop combinations.
- 5.6.2.1 Except as set forth in section 5.6.3 below, the rates at which BellSouth shall provide Currently Combined UNE port/loop combinations and not Currently Combined UNE port/loop combinations in the states of Georgia and Tennessee shall be the cost-based rates in Exhibit C.
- 5.6.2.2 The rates at which BellSouth shall provide not Currently Combined UNE port/loop combinations in Alabama, Florida, Kentucky, Louisiana, Mississippi, North Carolina and South Carolina shall be the market rates in Exhibit C.
- 5.6.3 BellSouth is not required to provide combinations of port and loop network elements on an unbundled basis in locations where, pursuant to FCC rules, BellSouth is not required to provide circuit switching as an unbundled network element.
- 5.6.3.1 BellSouth shall not be required to provide local circuit switching as an unbundled network element in density Zone 1, as defined in 47 CFR 69.123 as of January 1, 1999 of the Atlanta, GA; Miami, FL; Orlando, FL; Ft. Lauderdale, FL; Charlotte-Gastonia-Rock Hill, NC; Greensboro-Winston Salem-High Point, NC; Nashville, TN; and New Orleans, LA, MSAs to Heritage if Heritage's customer has 4 or more DS0 equivalent lines.
- 5.6.3.2 Notwithstanding the foregoing, BellSouth shall provide combinations of port and loop network elements on an unbundled basis where, pursuant to FCC rules, BellSouth is not required to provide local circuit switching as an unbundled network element and shall do so at the market rates in Exhibit C.
- 5.6.4 **Combination Offerings**
- 5.6.4.1 2-wire voice grade port, voice grade loop, unbundled end office switching, unbundled end office trunk port, common transport per mile per MOU, common transport facilities termination, tandem switching, and tandem trunk port.
- 5.6.4.2 2-wire voice grade Coin port, voice grade loop, unbundled end office switching, unbundled end office trunk port, common transport per mile per MOU, common transport facilities termination, tandem switching, and tandem trunk port.
- 5.6.4.3 2-wire voice grade DID port, voice grade loop, unbundled end office switching, unbundled end office trunk port, common transport per mile per MOU, common transport facilities termination, tandem switching, and tandem trunk port.

- 5.6.4.4 2-wire CENTREX port, voice grade loop, unbundled end office switching, unbundled end office trunk port, common transport per mile per MOU, common transport facilities termination, tandem switching, and tandem trunk port.
- 5.6.4.5 2-wire ISDN Basic Rate Interface, voice grade loop, unbundled end office switching, unbundled end office trunk port, common transport per mile per MOU, common transport facilities termination, tandem switching, and tandem trunk port.
- 5.6.4.6 4-wire ISDN Primary Rate Interface, DS1 loop, unbundled end office switching, unbundled end office trunk port, common transport per mile per MOU, common transport facilities termination, tandem switching, and tandem trunk port.
- 5.6.4.7 4-wire DS1 Trunk port, DS1 Loop, unbundled end office switching, unbundled end office trunk port, common transport per mile per MOU, common transport facilities termination, tandem switching, and tandem trunk port.
- 5.6.4.8 4-wire DS1 Loop with normal serving wire center channelization interface, 2-wire voice grade ports (PBX), 2-wire DID ports, unbundled end office switching, unbundled end office trunk port, common transport per mile per MOU, common transport facilities termination, tandem switching, and tandem trunk port.

6 Transport, Channelization and Dark Fiber

6.6 Transport

6.6.3 Interoffice transmission facility network elements include:

6.6.3.1 Dedicated transport, defined as BellSouth's transmission facilities, is dedicated to a particular customer or carrier that provides telecommunications between wire centers or switches owned by BellSouth, or between wire centers and switches owned by BellSouth and Heritage.

6.6.3.2 Dark Fiber transport, defined as BellSouth's optical transmission facilities without attached signal regeneration, multiplexing, aggregation or other electronics;

6.6.3.3 Common (Shared) transport, defined as transmission facilities shared by more than one carrier, including BellSouth, between end office switches, between end office switches and tandem switches, and between tandem switches, in BellSouth's network. Where BellSouth Network Elements are connected by intraoffice wiring, such wiring is provided as part of the Network Element and is not Common (Shared) Transport.

6.6.4 BellSouth shall:

6.6.4.1 Provide Heritage exclusive use of interoffice transmission facilities dedicated to a particular customer or carrier, or shared use of the features, functions, and

capabilities of interoffice transmission facilities shared by more than one customer or carrier;

- 6.6.4.2 Provide all technically feasible transmission facilities, features, functions, and capabilities of the transport facility for the provision of telecommunications services;
- 6.6.4.3 Permit, to the extent technically feasible, Heritage to connect such interoffice facilities to equipment designated by Heritage, including but not limited to, Heritage's collocated facilities; and
- 6.6.4.4 Permit, to the extent technically feasible, Heritage to obtain the functionality provided by BellSouth's digital cross-connect systems.
- 6.6.5 **Technical Requirements of Common (Shared) Transport**
 - 6.6.5.1 Common (Shared) Transport provided on DS1 or VT1.5 circuits, shall, at a minimum, meet the performance, availability, jitter, and delay requirements specified for Central Office to Central Office ("CO to CO") connections in the applicable industry standards.
 - 6.6.5.2 Common (Shared) Transport provided on DS3 circuits, STS-1 circuits, and higher transmission bit rate circuits, shall, at a minimum, meet the performance, availability, jitter, and delay requirements specified for CO to CO connections in the applicable industry standards.
 - 6.6.5.3 BellSouth shall be responsible for the engineering, provisioning, and maintenance of the underlying equipment and facilities that are used to provide Common (Shared) Transport.
 - 6.6.5.4 At a minimum, Common (Shared) Transport shall meet all of the requirements set forth in the applicable industry standards.
- 6.7 **Dedicated Transport**
 - 6.7.3 **Dedicated Transport is composed of the following Unbundled Network Elements:**
 - 6.7.3.1 **Unbundled Local Channel, defined as the dedicated transmission path between Heritage's Point of Presence("POP") and Heritage's collocation space in the BellSouth Serving Wire Center for Heritage's POP, and**
 - 6.7.3.2 **Unbundled Interoffice Channel, defined as the dedicated transmission path that provides telecommunication between BellSouth's Serving Wire Centers' collocations.**
 - 6.7.3.3 **BellSouth shall offer Dedicated Transport in each of the following ways:**

- 6.7.3.3.1 As capacity on a shared UNE facility.
- 6.7.3.3.2 As a circuit (e.g., DS0, DS1, DS3) dedicated to Heritage.
- 6.7.3.4 Dedicated Transport may be provided over facilities such as optical fiber, copper twisted pair, and coaxial cable, and shall include transmission equipment such as, line terminating equipment, amplifiers, and regenerators.
- 6.7.4 Technical Requirements
 - 6.7.4.1 The entire designated transmission service (e.g., DS0, DS1, DS3) shall be dedicated to Heritage designated traffic.
 - 6.7.4.2 For DS1 or VT1.5 circuits, Dedicated Transport shall, at a minimum, meet the performance, availability, jitter, and delay requirements specified for Customer Interface to Central Office ("CI to CO") connections in the applicable industry standards.
 - 6.7.4.3 For DS3 circuits, Dedicated Transport shall, at a minimum, meet the performance, availability, jitter, and delay requirements specified for CI to CO connections in the applicable industry standards.
 - 6.7.4.4 BellSouth shall offer the following interface transmission rates for Dedicated Transport:
 - 6.7.4.4.1 DS0 Equivalent;
 - 6.7.4.4.2 DS1;
 - 6.7.4.4.3 DS3; and
 - 6.7.4.4.4 SDH (Synchronous Digital Hierarchy) Standard interface rates in accordance with International Telecommunications Union (ITU) Recommendation G.707 and Plesiochronous Digital Hierarchy (PDH) rates per ITU Recommendation G.704.
 - 6.7.4.5 BellSouth shall design Dedicated Transport according to its network infrastructure. Heritage shall specify the termination points for Dedicated Transport.
 - 6.7.4.6 At a minimum, Dedicated Transport shall meet each of the requirements set forth in the applicable industry technical references.
 - 6.7.4.7 BellSouth Technical References:
 - 6.7.4.7.1 TR-TSY-000191 Alarm Indication Signals Requirements and Objectives, Issue 1, May 1986.

6.7.4.7.2 TR 73501 LightGate[®] Service Interface and Performance Specifications, Issue D, June 1995.

6.7.4.7.3 TR 73525 MegaLink[®] Service, MegaLink Channel Service and MegaLink Plus Service Interface and Performance Specifications, Issue C, May 1996.

6.8 **Unbundled Channelization (Multiplexing)**

6.8.3 Unbundled Channelization (UC) provides the multiplexing capability that will allow a DS1 (1.544 Mbps) or DS3 (44.736 Mbps) or STS-1 Unbundled Network Element (UNE) or collocation cross-connect to be multiplexed or channelized at a BellSouth central office. Channelization will be offered with both the high and low speed sides to be connected to collocation. Channelization can be accomplished through the use of a stand-alone multiplexer or a digital cross-connect system at the discretion of BellSouth. Once UC has been installed, Heritage may request channel activation on an as-needed basis and BellSouth shall connect the requested facilities via Central Office Channel Interfaces (COCI). The COCI must be compatible with the lower capacity facility and ordered with the lower capacity facility.

6.8.4 BellSouth shall make available the following channelization systems:

6.8.4.1 DS3 Channelization System: channelizes a DS3 signal into 28 DS1s/STS-1s.

6.8.4.2 DS1 Channelization System: channelizes a DS1 signal into 24 DS0s.

6.8.5 BellSouth shall make available the following

6.8.5.1 Central Office Channel Interfaces (COCI):

6.8.5.2 DS1 COCI, which can be activated on a DS3 Channelization System.

6.8.5.3 Voice Grade and Digital Data COCI, which can be activated on a DS1 Channelization System.

6.8.5.4 Data COCI, which can be activated on a DS1 Channelization System.

6.8.5.5 AMI and B8ZS line coding with either Super Frame (SF) and Extended Super Frame (ESF) framing formats will be supported as options.

6.8.6 Technical Requirements

6.8.6.1 In order to assure proper operation with BellSouth provided central office multiplexing functionality, Heritage's channelization equipment must adhere strictly to form and protocol standards. Heritage must also adhere to such applicable industry standards for the multiplex channel bank, for voice frequency encoding, for various signaling schemes, and for sub rate digital access.

6.8.6.2 DS0 to DS1 Channelization

6.8.6.2.1 The DS1 signal must be framed utilizing the framing structure defined in ANSI T1.107, Digital Hierarchy Formats Specifications and ANSI T1.403.02, DS1 Robbed-bit Signaling State Definitions.

6.8.6.3 DS1 to DS3 Channelization

6.8.6.3.1 The DS3 signal must be framed utilizing the framing structure define in ANSI T1.107, Digital Hierarchy Formats Specifications. The asynchronous M13 multiplex format (combination of M12 and M23 formats) is specified for terminal equipment that multiplexes 28 DS1s into a DS3.

6.8.6.4 DS1 to STS Channelization

6.8.6.4.1 The STS-1 signal must be framed utilizing the framing structure define in ANSI T1.105, Synchronous Optical Network (SONET) – Basic Description Including Multiplex Structure, Rates and Formats and T1.105.02, Synchronous Optical Network (SONET) – Payload Mappings.

6.9 **Dark Fiber Transport**

6.9.3 Dark Fiber Transport is an unused optical transmission facility without attached signal regeneration, multiplexing, aggregation or other electronics that connects two points within BellSouth's network. It may be strands of optical fiber existing in aerial or underground structure. BellSouth will not provide line terminating elements, regeneration or other electronics necessary for Heritage to utilize Dark Fiber Transport.

6.9.4 Dark Fiber Transport rates are differentiated between Local Channel, Interoffice Channel and Local Loop.

6.9.5 Requirements

6.9.5.1 BellSouth shall make available Dark Fiber Transport where it exists in BellSouth's network and where, as a result of future building or deployment, it becomes available. Dark Fiber Transport will not be deemed available if (1) it is used by BellSouth for maintenance and repair purposes, (2) it is designated for use pursuant to a firm order placed by another customer, (3) it is restricted for use by all carriers, including BellSouth, because of transmission problems or because it is scheduled for removal due to documented changes to roads and infrastructure, or (4) BellSouth has plans to use the fiber within a two-year planning period.
BellSouth is not required to place fibers for Dark Fiber Transport if there are none available.

- 6.9.5.2 If the requested Dark Fiber Transport has any lightwave repeater equipment interspliced to it, BellSouth will remove such equipment at Heritage's request subject to time and materials charges.
- 6.9.5.3 Heritage is solely responsible for testing the quality of the Dark Fiber Transport to determine its usability and performance specifications.
- 6.9.5.4 BellSouth shall use its best efforts to provide to Heritage information regarding the location, availability and performance of Dark Fiber Transport within ten (10) business days after receiving a request from Heritage. Within such time period, BellSouth shall send written confirmation of availability of the Dark Fiber Transport.
- 6.9.5.5 If the requested Dark Fiber Transport is available, BellSouth shall use its commercially reasonable efforts to provision the Dark Fiber Transport to Heritage within twenty (20) business days after Heritage submits a valid, error free LSR. Provisioning includes identification of appropriate connection points (e.g., Light Guide Interconnection (LGX) or splice points) to enable Heritage to connect or splice Heritage provided transmission media (e.g., optical fiber) or equipment to the Dark Fiber Transport.
- 6.9.5.6 Heritage may splice at the end points and test Dark Fiber Transport obtained from BellSouth using Heritage or Heritage designated personnel. BellSouth shall provide appropriate interfaces to allow splicing and testing of Dark Fiber Transport. For fiber in underground conduit, BellSouth shall provide a minimum of 25 feet of excess cable to allow the uncoiled fiber to reach from the manhole to a splicing van.
- 7 BellSouth Switched Access ("SWA") 8XX Toll Free Dialing Ten Digit Screening Service**
- 7.6 The BellSouth SWA 8XX Toll Free Dialing Ten Digit Screening Service database ("8XX SCP Database") is a Signaling control Point ("SCP") that contains customer record information and the functionality to provide call-handling instructions for 8XX calls. The 8XX SCP IN software stores data downloaded from the national SMS/8XX database and provides the routing instructions in response to queries from the Switching Service Point ("SSP") or tandem. The BellSouth SWA 8XX Toll Free Dialing Ten Digit Screening Service ("8XX TFD Service") utilizes the 8XX SCP Database to provide identification and routing of the 8XX calls, based on the ten digits dialed. At Heritage's option, 8XX TFD Service is provided with or without POTS number delivery, dialing number delivery, and other optional complex features as selected by Heritage.
- 7.7 The 8XX SCP Database is designated to receive and respond to queries using the ANSI Specification of Signaling System Seven (SS7) protocol.

8 Line Information Database (LIDB)

8.6 The Line Information Database (LIDB) is a transaction-oriented database accessible through Common Channel Signaling (CCS) networks. For access to LIDB, Heritage must purchase appropriate signaling links pursuant to Section 9 of this Attachment. LIDB contains records associated with end user Line Numbers and Special Billing Numbers. LIDB accepts queries from other Network Elements and provides appropriate responses. The query originator need not be the owner of LIDB data. LIDB queries include functions such as screening billed numbers that provides the ability to accept Collect or Third Number Billing calls and validation of Telephone Line Number based non-proprietary calling cards. The interface for the LIDB functionality is the interface between BellSouth's CCS network and other CCS networks. LIDB also interfaces to administrative systems.

8.7 Technical Requirements

8.7.3 BellSouth will offer to Heritage any additional capabilities that are developed for LIDB during the life of this Agreement.

8.7.4 BellSouth shall process Heritage's Customer records in LIDB at least at parity with BellSouth customer records, with respect to other LIDB functions. BellSouth shall indicate to Heritage what additional functions (if any) are performed by LIDB in the BellSouth network.

8.7.5 Within two (2) weeks after a request by Heritage, BellSouth shall provide Heritage with a list of the customer data items, which Heritage would have to provide in order to support each required LIDB function. The list shall indicate which data items are essential to LIDB function, and which are required only to support certain services. For each data item, the list shall show the data formats, the acceptable values of the data item and the meaning of those values.

8.7.6 BellSouth shall provide LIDB systems for which operating deficiencies that would result in calls being blocked shall not exceed 30 minutes per year.

8.7.7 BellSouth shall provide LIDB systems for which operating deficiencies that would not result in calls being blocked shall not exceed 12 hours per year.

8.7.8 BellSouth shall provide LIDB systems for which the LIDB function shall be in overload no more than 12 hours per year.

8.7.9 All additions, updates and deletions of Heritage data to the LIDB shall be solely at the direction of Heritage. Such direction from Heritage will not be required where the addition, update or deletion is necessary to perform standard fraud control measures (e.g., calling card auto-deactivation).

8.7.10 BellSouth shall provide priority updates to LIDB for Heritage data upon Heritage's request (e.g., to support fraud detection), via password-protected

telephone card, facsimile, or electronic mail within one hour of notice from the established BellSouth contact.

- 8.7.11 BellSouth shall provide LIDB systems such that no more than 0.01% of Heritage customer records will be missing from LIDB, as measured by Heritage audits. BellSouth will audit Heritage records in LIDB against DBAS to identify record mismatches and provide this data to a designated Heritage contact person to resolve the status of the records and BellSouth will update system appropriately. BellSouth will refer record of mis-matches to Heritage within one business day of audit. Once reconciled records are received back from Heritage, BellSouth will update LIDB the same business day if less than 500 records are received before 1:00PM Central Time. If more than 500 records are received, BellSouth will contact Heritage to negotiate a time frame for the updates, not to exceed three business days.
- 8.7.12 BellSouth shall perform backup and recovery of all of Heritage's data in LIDB including sending to LIDB all changes made since the date of the most recent backup copy, in at least the same time frame BellSouth performs backup and recovery of BellSouth data in LIDB for itself. Currently, BellSouth performs backups of the LIDB for itself on a weekly basis and when a new software release is scheduled, a backup is performed prior to loading the new release.
- 8.7.13 BellSouth shall provide Heritage with LIDB reports of data, which are missing or contain errors, as well as any misrouted errors, within a reasonable time period as negotiated between Heritage and BellSouth.
- 8.7.14 BellSouth shall prevent any access to or use of Heritage data in LIDB by BellSouth personnel that are outside of established administrative and fraud control personnel, or by any other Party that is not authorized by Heritage in writing.
- 8.7.15 BellSouth shall provide Heritage performance of the LIDB Data Screening function, which allows a LIDB to completely or partially deny specific query originators access to LIDB data owned by specific data owners, for Customer Data that is part of an NPA-NXX or RAO-0/1XX wholly or partially owned by Heritage at least at parity with BellSouth Customer Data. BellSouth shall obtain from Heritage the screening information associated with LIDB Data Screening of Heritage data in accordance with this requirement. BellSouth currently does not have LIDB Data Screening capabilities. When such capability is available, BellSouth shall offer it to Heritage under the BFR/NBR process as set forth in Attachment 12.
- 8.7.16 BellSouth shall accept queries to LIDB associated with Heritage customer records, and shall return responses in accordance with industry standards.

- 8.7.17 BellSouth shall provide mean processing time at the LIDB within 0.50 seconds under normal conditions as defined in industry standards.
- 8.7.18 BellSouth shall provide processing time at the LIDB within 1 second for 99% of all messages under normal conditions as defined in industry standards.
- 8.8 Interface Requirements
- 8.8.3 BellSouth shall offer LIDB in accordance with the requirements of this subsection.
- 8.8.4 The interface to LIDB shall be in accordance with the technical references contained within.
- 8.8.5 The CCS interface to LIDB shall be the standard interface described herein.
- 8.8.6 The LIDB Data Base interpretation of the ANSI-TCAP messages shall comply with the technical reference herein. Global Title Translation shall be maintained in the signaling network in order to support signaling network routing to the LIDB.
- 9 **Signaling**
- 9.6 BellSouth shall offer access to signaling and access to BellSouth's signaling databases subject to compatibility testing and at the rates set forth in this Attachment. BellSouth may provide mediated access to BellSouth signaling systems and databases. Available signaling elements include signaling links, signal transfer points and service control points. Signaling functionality will be available with both A-link and B-link connectivity.
- 9.7 **Signaling Link Transport**
- 9.7.3 Signaling Link Transport is a set of two or four dedicated 56 kbps transmission paths between Heritage-designated Signaling Points of Interconnection that provide appropriate physical diversity.
- 9.7.4 Technical Requirements
- 9.7.5 Signaling Link Transport shall consist of full duplex mode 56 kbps transmission paths and shall perform in the following two ways:
- 9.7.5.1 As an "A-link" Signaling Link Transport is a connection between a switch or SCP and a home Signaling Transfer Point switch pair; and
- 9.7.5.2 As a "B-link" Signaling Link Transport is a connection between two Signaling Transfer Point switch pairs in different company networks (e.g., between two Signaling Transfer Point switch pairs for two CLECs).
- 9.7.6 Signaling Link Transport shall consist of two or more signaling link layers as follows:

- 9.7.6.1 An A-link layer shall consist of two links.
- 9.7.6.2 A B-link layer shall consist of four links.
- 9.7.6.3 A signaling link layer shall satisfy interoffice and intraoffice diversity of facilities and equipment, such that:
 - 9.7.6.4 No single failure of facilities or equipment causes the failure of both links in an A-link layer (i.e., the links should be provided on a minimum of two separate physical paths end-to-end); and
 - 9.7.6.5 No two concurrent failures of facilities or equipment shall cause the failure of all four links in a B-link layer (i.e., the links should be provided on a minimum of three separate physical paths end-to-end).
- 9.7.7 Interface Requirements
 - 9.7.7.1 There shall be a DS1 (1.544 Mbps) interface at Heritage's designated SPOIs. Each 56 kbps transmission path shall appear as a DS0 channel within the DS1 interface.
- 9.8 **Signaling Transfer Points (STPs)**
 - 9.8.3 A Signaling Transfer Point is a signaling network function that includes all of the capabilities provided by the signaling transfer point switches (STPs) and their associated signaling links that enables the exchange of SS7 messages among and between switching elements, database elements and signaling transfer point switches.
 - 9.8.4 **Technical Requirements**
 - 9.8.4.1 Signaling Transfer Points shall provide access to BellSouth Local Switching or Tandem Switching and to BellSouth Service Control Points/Databases connected to BellSouth SS7 network. Signaling Transfer Points also provide access to third-party local or tandem switching and Third-party-provided Signaling Transfer Points.
 - 9.8.4.2 The connectivity provided by Signaling Transfer Points shall fully support the functions of all other Network Elements connected to the BellSouth SS7 network. This includes the use of the BellSouth SS7 network to convey messages that neither originate nor terminate at a signaling end point directly connected to the BellSouth SS7 network (i.e., transit messages). When the BellSouth SS7 network is used to convey transit messages, there shall be no alteration of the Integrated Services Digital Network User Part or Transaction Capabilities Application Part (TCAP) user data that constitutes the content of the message.

- 9.8.4.3 If a BellSouth tandem switch routes traffic, based on dialed or translated digits, on SS7 trunks between a Heritage local switch and third party local switch, the BellSouth SS7 network shall convey the TCAP messages that are necessary to provide Call Management features (Automatic Callback, Automatic Recall, and Screening List Editing) between Heritage local STPs and the STPs that provide connectivity with the third party local switch, even if the third party local switch is not directly connected to BellSouth STPs.
- 9.8.4.4 STPs shall provide all functions of the SCCP necessary for Class 0 (basic connectionless) service, as defined in Telcordia ANSI Interconnection Requirements. This includes Global Title Translation (GTT) and SCCP Management procedures, as specified in ANSI T1.112.4. Where the destination signaling point is a Heritage or third party local or tandem switching system directly connected to BellSouth SS7 network, BellSouth shall perform final GTT of messages to the destination and SCCP Subsystem Management of the destination. In all other cases, BellSouth shall perform intermediate GTT of messages to a gateway pair of STPs in an SS7 network connected with BellSouth SS7 network, and shall not perform SCCP Subsystem Management of the destination. If BellSouth performs final GTT to a Heritage database, then Heritage agrees to provide BellSouth with the Destination Point Code for Heritage database.
- 9.8.4.5 STPs shall provide all functions of the OMAP as specified in applicable industry standard technical references, which may include, where available in BellSouth's network, MTP Routing Verification Test (MRVT); and SCCP Routing Verification Test (SRVT).
- 9.8.4.6 Where the destination signaling point is a BellSouth local or tandem switching system or database, or is a Heritage or third party local or tandem switching system directly connected to the BellSouth SS7 network, STPs shall perform MRVT and SRVT to the destination signaling point. In all other cases, STPs shall perform MRVT and SRVT to a gateway pair of STPs in an SS7 network connected with the BellSouth SS7 network. This requirement may be superseded by the specifications for Internetwork MRVT and SRVT when these become approved ANSI standards and available capabilities of BellSouth STPs.
- 9.9 **SS7 Advanced Intelligent Network (AIN) Access**
- 9.9.3 When technically feasible and upon request by Heritage, SS7 AIN Access shall be made available in association with switching. SS7 AIN Access is the provisioning of AIN 0.1 triggers in an equipped BellSouth local switch and interconnection of the BellSouth SS7 network with Heritage's SS7 network to exchange TCAP queries and responses with a Heritage SCP.
- 9.9.4 SS7 AIN Access shall provide Heritage SCP access to an equipped BellSouth local switch via interconnection of BellSouth's SS7 and Heritage SS7 Networks.

BellSouth shall offer SS7 AIN Access through its STPs. If BellSouth requires a mediation device on any part of its network specific to this form of access, BellSouth must route its messages in the same manner. The interconnection arrangement shall result in the BellSouth local switch recognizing the Heritage SCP as at least at parity with BellSouth's SCPs in terms of interfaces, performance and capabilities.

9.9.5 Interface Requirements

9.9.5.1 BellSouth shall provide the following STP options to connect Heritage or Heritage-designated local switching systems to the BellSouth SS7 network:

9.9.5.1.1 An A-link interface from Heritage local switching systems; and,

9.9.5.1.2 A B-link interface from Heritage local STPs.

9.9.5.2 Each type of interface shall be provided by one or more layers of signaling links.

9.9.5.3 The Signaling Point of Interconnection for each link shall be located at a cross-connect element in the Central Office (CO) where the BellSouth STP is located. There shall be a DS1 or higher rate transport interface at each of the SPOIs. Each signaling link shall appear as a DS0 channel within the DS1 or higher rate interface.

9.9.5.4 BellSouth shall provide intraoffice diversity between the Signaling Point of Interconnection and BellSouth STPs, so that no single failure of intraoffice facilities or equipment shall cause the failure of both B-links in a layer connecting to a BellSouth STP.

9.9.5.5 STPs shall provide all functions of the MTP as defined in the applicable industry standard technical references.

9.9.6 Message Screening

9.9.6.1 BellSouth shall set message screening parameters so as to accept valid messages from Heritage local or tandem switching systems destined to any signaling point within BellSouth's SS7 network where the Heritage switching system has a valid signaling relationship.

9.9.6.2 BellSouth shall set message screening parameters so as to pass valid messages from Heritage local or tandem switching systems destined to any signaling point or network accessed through BellSouth's SS7 network where the Heritage switching system has a valid signaling relationship.

9.9.6.3 BellSouth shall set message screening parameters so as to accept and pass/send valid messages destined to and from Heritage from any signaling point or network

interconnected through BellSouth's SS7 network where the Heritage SCP has a valid signaling relationship.

9.10 **Service Control Points/Databases**

9.10.3 Call Related Databases provide the storage of, access to, and manipulation of information required to offer a particular service and/or capability. BellSouth shall provide access to the following Databases: Local Number Portability, LIDB, Toll Free Number Database, Automatic Location Identification/Data Management System, and Calling Name Database. BellSouth also provides access to Service Creation Environment and Service Management System (SCE/SMS) application databases and Directory Assistance.

9.10.4 A Service Control Point (SCP) is deployed in a SS7 network that executes service application logic in response to SS7 queries sent to it by a switching system also connected to the SS7 network. Service Management Systems provide operational interfaces to allow for provisioning, administration and maintenance of subscriber data and service application data stored in SCPs.

9.10.5 **Technical Requirements for SCPs/Databases**

9.10.5.1 BellSouth shall provide physical access to SCPs through the SS7 network and protocols with TCAP as the application layer protocol.

9.10.5.2 BellSouth shall provide physical interconnection to databases via industry standard interfaces and protocols (e.g. SS7, ISDN and X.25).

9.10.5.3 The reliability of interconnection options shall be consistent with requirements for diversity and survivability.

9.11 **Local Number Portability Database**

9.11.3 The Permanent Number Portability (PNP) database supplies routing numbers for calls involving numbers that have been ported from one local service provider to another. BellSouth agrees to provide access to the PNP database at rates, terms and conditions as set forth by BellSouth and in accordance with an effective FCC or Commission directive.

9.12 **SS7 Network Interconnection**

9.12.3 **SS7 Network Interconnection** is the interconnection of Heritage local signaling transfer point switches or Heritage local or tandem switching systems with BellSouth signaling transfer point switches. This interconnection provides connectivity that enables the exchange of SS7 messages among BellSouth switching systems and databases, Heritage local or tandem switching systems, and other third-party switching systems directly connected to the BellSouth SS7 network.

- 9.12.4 The connectivity provided by SS7 Network Interconnection shall fully support the functions of BellSouth switching systems and databases and Heritage or other third-party switching systems with A-link access to the BellSouth SS7 network.
- 9.12.5 If traffic is routed based on dialed or translated digits between a Heritage local switching system and a BellSouth or other third-party local switching system, either directly or via a BellSouth tandem switching system, then it is a requirement that the BellSouth SS7 network convey via SS7 Network Interconnection the TCAP messages that are necessary to provide Call Management services (Automatic Callback, Automatic Recall, and Screening List Editing) between the Heritage local signaling transfer point switches and BellSouth or other third-party local switch.
- 9.12.6 SS7 Network Interconnection shall provide:
 - 9.12.6.1 Signaling Data Link functions, as specified in ANSI T1.111.2;
 - 9.12.6.2 Signaling Link functions, as specified in ANSI T1.111.3; and
 - 9.12.6.3 Signaling Network Management functions, as specified in ANSI T1.111.4.
- 9.12.7 SS7 Network Interconnection shall provide all functions of the SCCP necessary for Class 0 (basic connectionless) service, as specified in ANSI T1.112. This includes Global Title Translation (GTT) and SCCP Management procedures, as specified in ANSI T1.112.4. Where the destination signaling point is a BellSouth switching system or DB, or is another third-party local or tandem switching system directly connected to the BellSouth SS7 network, SS7 Network Interconnection shall include final GTT of messages to the destination and SCCP Subsystem Management of the destination. Where the destination signaling point is a Heritage local or tandem switching system, SS7 Network Interconnection shall include intermediate GTT of messages to a gateway pair of Heritage local STPs, and shall not include SCCP Subsystem Management of the destination.
- 9.12.8 SS7 Network Interconnection shall provide all functions of the Integrated Services Digital Network User Part, as specified in ANSI T1.113.
- 9.12.9 SS7 Network Interconnection shall provide all functions of the TCAP, as specified in ANSI T1.114.
- 9.12.10 If Internetwork MRVT and SRVT become approved ANSI standards and available capabilities of BellSouth STPs, SS7 Network Interconnection may provide these functions of the OMAP.
- 9.12.11 Interface Requirements

- 9.12.11.1 The following SS7 Network Interconnection interface options are available to connect Heritage or Heritage-designated local or tandem switching systems or signaling transfer point switches to the BellSouth SS7 network:
 - 9.12.11.1.1 A-link interface from Heritage local or tandem switching systems; and
 - 9.12.11.1.2 B-link interface from Heritage STPs.
- 9.12.11.2 The Signaling Point of Interconnection for each link shall be located at a cross-connect element in the central office where the BellSouth STP is located. There shall be a DS1 or higher rate transport interface at each of the Signaling Points of interconnection. Each signaling link shall appear as a DS0 channel within the DS1 or higher rate interface.
- 9.12.11.3 BellSouth shall provide intraoffice diversity between the Signaling Points of Interconnection and the BellSouth STP, so that no single failure of intraoffice facilities or equipment shall cause the failure of both B-links in a layer connecting to a BellSouth STP.
- 9.12.11.4 The protocol interface requirements for SS7 Network Interconnection include the MTP, ISDNUP, SCCP, and TCAP. These protocol interfaces shall conform to the applicable industry standard technical references.
- 9.12.11.5 BellSouth shall set message screening parameters to accept messages from Heritage local or tandem switching systems destined to any signaling point in the BellSouth SS7 network with which the Heritage switching system has a valid signaling relationship.

10 Operator Service and Directory Assistance

- 10.6 Operator Service provides: (1) operator handling for call completion (for example, collect, third number billing, and manual calling-card calls), (2) operator or automated assistance for billing after the end user has dialed the called number (for example, calling card calls); and (3) special services including but not limited to Busy Line Verification and Emergency Line Interrupt (ELI), Emergency Agency Call, and Operator-assisted Directory Assistance.
- 10.7 Upon request for BellSouth Operator Services, BellSouth shall:
 - 10.7.3 Process 0+ and 0- dialed local calls.
 - 10.7.4 Process 0+ and 0- intraLATA toll calls.
 - 10.7.5 Process calls that are billed to Heritage end user's calling card that can be validated by BellSouth.
 - 10.7.6 Process person-to-person calls.

- 10.7.7 Process collect calls.
- 10.7.8 Provide the capability for callers to bill to a third party and shall also process such calls.
- 10.7.9 Process station-to-station calls.
- 10.7.10 Process Busy Line Verify and Emergency Line Interrupt requests.
- 10.7.11 Process emergency call trace originated by Public Safety Answering Points.
- 10.7.12 Process operator-assisted directory assistance calls.
- 10.7.13 Adhere to equal access requirements, providing Heritage local end users the same IXC access as provided to BellSouth end users.
- 10.7.14 Exercise at least the same level of fraud control in providing Operator Service to Heritage that BellSouth provides for its own operator service.
- 10.7.15 Perform Billed Number Screening when handling Collect, Person-to-Person, and Billed-to-Third-Party calls.
- 10.7.16 Direct customer account and other similar inquiries to the customer service center designated by Heritage.
- 10.7.17 Provide call records to Heritage in accordance with ODUF standards specified in Attachment 7.
- 10.7.18 The interface requirements shall conform to the interface specifications for the platform used to provide Operator Services as long as the interface conforms to industry standards.
- 10.8 **Directory Assistance Service**
- 10.8.3 Directory Assistance Service provides local end user telephone number listings with the option to complete the call at the caller's direction separate and distinct from local switching.
- 10.8.4 Directory Assistance Service shall provide up to two listing requests per call. If available and if requested by Heritage's end user, BellSouth shall provide caller-optional directory assistance call completion service at rates contained in this Attachment to one of the provided listings.
- 10.8.5 **Directory Assistance Service Updates**
- 10.8.5.1 BellSouth shall update end user listings changes daily. These changes include:
 - 10.8.5.1.1 New end user connections

- 10.8.5.1.2 End user disconnections
- 10.8.5.1.3 **End user address changes**
- 10.8.5.2 These updates shall also be provided for non-listed and non-published numbers for use in emergencies.
- 10.9 **Branding for Operator Call Processing and Directory Assistance**
- 10.9.3 BellSouth's branding feature provides a definable announcement to Heritage end users using Directory Assistance (DA)/Operator Call Processing (OCP) prior to placing such end users in queue or connecting them to an available operator or automated operator system. This feature allows Heritage to have its calls custom branded with Heritage's name on whose behalf BellSouth is providing Directory Assistance and/or Operator Call Processing. Rates for the branding features are set forth in this Attachment.
- 10.9.4 BellSouth offers three (3) service levels of branding to Heritage when ordering BellSouth's Directory Assistance and Operator Call Processing.
- 10.9.4.1 Service Level 1 - BellSouth Branding
- 10.9.4.2 Service Level 2 - Unbranding
- 10.9.4.3 Service Level 3 - Custom Branding
- 10.9.5 Where Heritage resells BellSouth's services or purchases unbundled local switching from BellSouth, and utilizes a directory assistance provider and operator services provider other than BellSouth, BellSouth will route Heritage's end user calls to that provider through Selective Carrier Routing.
- 10.9.6 **For Resellers and Use with an Unbundled Port**
- 10.9.6.1 Selective Call Routing using Line Class Codes (SCR-LCC) provides the capability for Heritage to have its OS/DA calls routed to BellSouth's OS/DA platform for BellSouth provided Custom Branded or Unbranded OS/DA or to its own or an alternate OS/DA platform for Self-Branded OS/DA. SCR-LCC is only available if line class code capacity is available in the requested BellSouth end office switches.
- 10.9.6.2 Custom Branding for Directory Assistance is not available for certain classes of service, including but not limited to Hotel/Motel services, WATS service, and certain PBX services.
- 10.9.6.3 Where available, Heritage specific and unique line class codes are programmed in each BellSouth end office switch where Heritage intends to serve end users with customized OS/DA branding. The line class codes specifically identify Heritage's end users so OS/DA calls can be routed over the appropriate trunk group to the

requested OS/DA platform. Additional line class codes are required in each end office if the end office serves multiple NPAs (i.e., a unique LCC is required per NPA), and/or if the end office switch serves multiple rate areas and Heritage intends to provide Heritage -branded OS/DA to its end users in these multiple rate areas.

- 10.9.6.4 BellSouth Branding is the Default Service Level.
- 10.9.6.5 SCR-LCC supporting Custom Branding and Self Branding require Heritage to order dedicated trunking from each BellSouth end office identified by Heritage, either to the BellSouth Traffic Operator Position System (TOPS) for Custom Branding or to the Heritage Operator Service Provider for Self Branding. Separate trunk groups are required for Operator Services and for Directory Assistance. Rates for trunks are set forth in applicable BellSouth tariffs.
- 10.9.6.6 Unbranding - Unbranded Directory Assistance and/or Operator Call Processing calls ride common trunk groups provisioned by BellSouth from those end offices identified by Heritage to the BellSouth TOPS. These calls are routed to "No Announcement."
- 10.9.6.7 The Rates for SCR-LCC are as set forth in this Attachment. There is a nonrecurring charge for the establishment of each Line Class Code in each BellSouth central office. Furthermore, for Unbranded and Custom Branded OS/DA provided by BellSouth Operator Services with unbundled ports and unbundled port/loop switch combinations, monthly recurring usage charges shall apply for the UNEs necessary to provide the service, such as end office and tandem switching and common transport. A flat rated end office switching charge shall apply to Self-Branded OS/DA when used in conjunction with unbundled ports and unbundled port/loop switch combinations.
- 10.9.6.8 In addition to the branding methods described in this Section, Unbranding and Custom Branding are also available for Directory Assistance, Operator Call Processing or both via Originating Line Number Screening (OLNS) software. When utilizing this method of Unbranding or Custom Branding, Heritage shall not be required to purchase dedicated trunking.
- 10.9.6.9 For BellSouth to provide Unbranding or Custom Branding via OLNS software for Operator Call Processing or for Directory Assistance, Heritage must have its Operating Company Number ("OCN(s)") and telephone numbers reside in BellSouth's LIDB; however, a BellSouth LIDB Storage Agreement is not required. To implement Unbranding and Custom Branding via OLNS software, Heritage must submit a manual order form which requires, among other things, Heritage's OCN and a forecast for the traffic volume anticipated for each BellSouth TOPS during the peak busy hour. Heritage shall provide updates to such forecast on a quarterly basis and at any time such forecasted traffic volumes are expected to change significantly. Upon Heritage's purchase of Unbranding or

Custom Branding using OLNS software for any particular TOPS, all Heritage end users served by that TOPS will receive the Unbranded “no announcement” or the Custom Branded announcement.

10.9.6.10 Rates for Unbranding and Custom Branding via OLNS software for Directory Assistance and for Operator Call Processing are as set forth in this Attachment. Notwithstanding anything to the contrary in this Agreement, to the extent BellSouth is unable to bill Heritage applicable charges currently, BellSouth shall track such charges and will bill the same retroactively at such time as a billing process is implemented. In addition to the charges for Unbranding and Custom Branding via OLNS software, Heritage shall continue to pay BellSouth applicable labor and other charges for the use of BellSouth’s Directory Assistance and Operator Call Processing platforms as set forth in this Attachment. Further, where Heritage is purchasing unbundled local switching from BellSouth, UNE usage charges for end office switching, tandem switching and transport, as applicable, shall continue to apply.

10.9.7 **For Facilities Based Carriers**

10.9.7.1 All Service Levels require Heritage to order dedicated trunking from their end office(s) point of interface to the BellSouth TOPS Switches. Rates for trunks are set forth in applicable BellSouth tariffs.

10.9.7.2 Customized Branding includes charges for the recording of the branding announcement and the loading of the audio units in each TOPS Switch and Network Applications Vehicle (NAV) equipment for which Heritage requires service.

10.9.7.3 Directory Assistance customized branding uses:

10.9.7.3.1 the recording of Heritage;

10.9.7.3.2 the front-end loading of the Digital Recorded Announcement Machine (DRAM) in each TOPS switch.

10.9.7.4 Operator Call Processing customized branding uses:

10.9.7.4.1 the recording of Heritage;

10.9.7.4.2 the front-end loading of the DRAM in the TOPS Switch;

10.9.7.4.3 the 0- automation loading for the audio units in the Enhanced Billing and Access Service (EBAS) in the Network Applications Vehicle (NAV).

10.10 **Directory Assistance Database Service (DADS)**

- 10.10.3 BellSouth shall make its Directory Assistance Database Service (DADS) available at the rates set forth in this Attachment solely for the expressed purpose of providing Directory Assistance type services to Heritage end users. The term "end user" denotes any entity that obtains Directory Assistance type services for its own use from a DADS customer. Directory Assistance type service is defined as Voice Directory Assistance (DA Operator assisted) and Electronic Directory Assistance (Data System assisted). Heritage agrees that DADS will not be used for any purpose that violates federal or state laws, statutes, regulatory orders or tariffs. For the purposes of provisioning a Directory Assistance type service, all terms and conditions of GSST A38 apply and are incorporated by reference herein. Except for the permitted uses, Heritage agrees not to disclose DADS to others and shall provide due care in providing for the security and confidentiality of DADS.
- 10.10.4 BellSouth shall initially provide Heritage with a Base File of subscriber listings which reflect all listing change activity occurring since Heritage's most recent update via magnetic tape. DADS is available and may be ordered on a Business, Residence or combined Business and Residence listings basis for each central office requested. BellSouth will require approximately 30- 45 days after receiving an order from Heritage to prepare the Base File.
- 10.10.5 BellSouth will provide updates at least weekly reflecting all listing change activity occurring since Heritage's previous update. Delivery of updates will commence immediately after Heritage receives the Base File. Updates will be provided via magnetic tape unless BellSouth and Heritage mutually develop CONNECT: Direct™ electronic connectivity. Heritage will pay all costs associated with CONNECT: Direct™ connectivity, which will vary depending upon volume and mileage.
- 10.10.6 Heritage authorizes the inclusion of Heritage Directory Assistance listings in the BellSouth Directory Assistance products, including but not limited to DADS. Any other use is not authorized.
- 10.11 **Direct Access to Directory Assistance Service**
- 10.11.3 Direct Access to Directory Assistance Service (DADAS) will provide Heritage's directory assistance operators with the ability to search all available BellSouth subscriber listings using the Directory Assistance search format. Subscription to DADAS will allow Heritage to utilize its own switch, operator workstations and optional audio subsystems.
- 10.11.4 Rates, terms and conditions for provisioning DADAS are as set forth in the FCC tariff No. 1.
- 11 **Automatic Location Identification/Data Management System (ALI/DMS)**
- 11.6 The ALI/DMS Database contains end user information (including name, address, telephone information, and sometimes special information from the local service

provider or end user) used to determine to which Public Safety Answering Point ("PSAP") to route the call. The ALI/DMS database is used to provide enhanced routing flexibility for E911.

11.7 Technical Requirements

11.7.3 BellSouth shall provide Heritage a data link to the ALI/DMS database or permit Heritage to provide its own data link to the ALI/DMS database. BellSouth shall provide error reports from the ALI/DMS database to Heritage after Heritage inputs end user information into the ALI/DMS database. Alternately, Heritage may request that BellSouth enter Heritage's end user information into the database, and validate end user information.

11.7.4 When BellSouth is responsible for administering the ALI/DMS database in its entirety, ported number NXXs entries for the ported numbers should be maintained unless Heritage requests otherwise and shall be updated if Heritage requests, provided Heritage supplies BellSouth with the updates.

11.7.5 When Remote Call Forwarding (RCF) is used to provide number portability to the local end user and a remark or other appropriate field information is available in the database, the shadow or "forwarded-to" number and an indication that the number is ported shall be added to the customer record.

11.7.6 If BellSouth is responsible for configuring PSAP features (for cases when the PSAP or BellSouth supports an ISDN interface) it shall ensure that CLASS Automatic Recall (Call Return) is not used to call back to the ported number. Although BellSouth currently does not have ISDN interface, BellSouth agrees to comply with this requirement once ISDN interfaces are in place.

11.8 Interface Requirements

11.8.3 The interface between the E911 Switch or Tandem and the ALI/DMS database for Heritage end users shall meet industry standards.

12 Calling Name (CNAM) Database Service

12.6 CNAM is the ability to associate a name with the calling party number, allowing the end user (to which a call is being terminated) to view the calling party's name before the call is answered. This service also provides Heritage the opportunity to load and store its subscriber names in the BellSouth CNAM SCPs.

12.7 Heritage shall submit to BellSouth a notice of its intent to access and utilize BellSouth CNAM Database Services. Said notice shall be in writing, no less than 60 days prior to Heritage's access to BellSouth's CNAM Database Services and shall be addressed to Heritage's Account Manager.

- 12.8 BellSouth's provision of CNAM Database Services to Heritage requires interconnection from Heritage to BellSouth CNAM Service Control Points (SCPs). Such interconnections shall be established pursuant to Attachment 3 of this Agreement, incorporated herein by this reference.
- 12.9 In order to formulate a CNAM query to be sent to the BellSouth CNAM SCP, Heritage shall provide its own CNAM SSP. Heritage's CNAM SSPs must be compliant with TR-NWT-001188, "CLASS Calling Name Delivery Generic Requirements".
- 12.10 If Heritage elects to access the BellSouth CNAM SCP via a third party CCS7 transport provider, the third party CCS7 provider shall interconnect with the BellSouth CCS7 network according to BellSouth's Common Channel Signaling Interconnection Guidelines and Telcordia's CCS Network Interface Specification document, TR-TSV-000905. In addition, the third party provider shall establish CCS7 interconnection at the BellSouth Local Signal Transfer Points (LSTPs) serving the BellSouth CNAM SCPs that Heritage desires to query.
- 12.11 If Heritage queries the BellSouth CNAM SCP via a third party national SS7 transport provider, the third party SS7 provider shall interconnect with the BellSouth CCS7 network according to BellSouth's Common Channel Signaling Interconnection Guidelines and Telcordia's CCS Network Interface Specification document, TR-TSV-000905. In addition, the third party provider shall establish SS7 interconnection at one or more of the BellSouth Gateway Signal Transfer Points (STPs). The payment of all costs associated with the transport of SS7 signals via a third party will be established by mutual agreement of the Parties and this Agreement shall be amended in accordance with modification of the General Terms and Conditions incorporated herein by this reference.
- 12.12 The mechanism to be used by Heritage for initial CNAM record load and/or updates shall be determined by mutual agreement. The initial load and all updates shall be provided by Heritage in the BellSouth specified format and shall contain records for every working telephone number that can originate phone calls. It is the responsibility of Heritage to provide accurate information to BellSouth on a current basis.
- 12.13 Updates to the SMS shall occur no less than once a week, reflect service order activity affecting either name or telephone number, and involve only record additions, deletions or changes.
- 12.14 Heritage CNAM records provided for storage in the BellSouth CNAM SCP shall be available, on a SCP query basis only, to all Parties querying the BellSouth CNAM SCP. Further, CNAM service shall be provided by each Party consistent with state and/or federal regulation.

- 13 Service Creation Environment and Service Management System (SCE/SMS) Advanced Intelligent Network (AIN) Access**
- 13.6 BellSouth's Service Creation Environment and Service Management System (SCE/SMS) Advanced Intelligent Network (AIN) Access shall provide Heritage the capability to create service applications in a BellSouth SCE and deploy those applications in a BellSouth SMS to a BellSouth SCP.
- 13.7 BellSouth's SCE/SMS AIN Access shall provide access to SCE hardware, software, testing and technical support (e.g., help desk, system administrator) resources available to Heritage. Training, documentation, and technical support will address use of SCE and SMS access and administrative functions, but will not include support for the creation of a specific service application.
- 13.8 BellSouth SCP shall partition and protect Heritage service logic and data from unauthorized access.
- 13.9 When Heritage selects SCE/SMS AIN Access, BellSouth shall provide training, documentation, and technical support to enable Heritage to use BellSouth's SCE/SMS AIN Access to create and administer applications.
- 13.9.3 Heritage access will be provided via remote data connection (e.g., dial-in, ISDN).
- 13.9.4 BellSouth shall allow Heritage to download data forms and/or tables to BellSouth SCP via BellSouth SMS without intervention from BellSouth.
- 14 Basic 911 and E911**
- 14.6 Basic 911 and E911 provides a caller access to the applicable emergency service bureau by dialing 911.
- 14.7 Basic 911 Service Provisioning. BellSouth will provide to Heritage a list consisting of each municipality that subscribes to Basic 911 service. The list will also provide, if known, the E911 conversion date for each municipality and, for network routing purposes, a ten-digit directory number representing the appropriate emergency answering position for each municipality subscribing to 911. Heritage will be required to arrange to accept 911 calls from its end users in municipalities that subscribe to Basic 911 service and translate the 911 call to the appropriate 10-digit directory number as stated on the list provided by BellSouth. Heritage will be required to route that call to BellSouth at the appropriate tandem or end office. When a municipality converts to E911 service, Heritage will be required to begin using E911 procedures.
- 14.8 E911 Service Provisioning. Heritage shall install a minimum of two dedicated trunks originating from the Heritage serving wire center and terminating to the appropriate E911 tandem. The dedicated trunks shall be, at a minimum, DS-0 level trunks configured either as a 2-wire analog interface or as part of a digital

(1.544 Mb/s) interface. Either configuration shall use CAMA-type signaling with multifrequency ("MF") pulsing that will deliver automatic number identification ("ANI") with the voice portion of the call. If the user interface is digital, MF pulses, as well as other AC signals, shall be encoded per the u-255 Law convention. Heritage will be required to provide BellSouth daily updates to the E911 database. Heritage will be required to forward 911 calls to the appropriate E911 tandem, along with ANI, based upon the current E911 end office to tandem homing arrangement as provided by BellSouth. If the E911 tandem trunks are not available, Heritage will be required to route the call to a designated 7-digit local number residing in the appropriate Public Service Answering Point ("PSAP"). This call will be transported over BellSouth's interoffice network and will not carry the ANI of the calling party. Heritage shall be responsible for providing BellSouth with complete and accurate data for submission to the 911/E911 database for the purpose of providing 911/E911 to its end users.

14.9 Rates. Charges for 911/E911 service are borne by the municipality purchasing the service. BellSouth will impose no charge on Heritage beyond applicable charges for BellSouth trunking arrangements.

14.10 Basic 911 and E911 functions provided to Heritage shall be at least at parity with the support and services that BellSouth provides to its end users for such similar functionality.

14.11 Detailed Practices and Procedures. The detailed practices and procedures contained in the E911 Local Exchange Carrier Guide For Facility-Based Providers as amended from time to time during the term of this Agreement will determine the appropriate practices and procedures for BellSouth and Heritage to follow in providing 911/E911 services.

15 **Operational Support Systems (OSS)**

15.6 BellSouth has developed and made available the following electronic interfaces by which Heritage may submit LSRs electronically.

LENS	Local Exchange Navigation System
EDI	Electronic Data Interchange
TAG	Telecommunications Access Gateway

15.7 LSRs submitted by means of one of these electronic interfaces will incur an OSS electronic ordering charge. An individual LSR will be identified for billing purposes by its Purchase Order Number (PON). LSRs submitted by means other than one of these interactive interfaces (mail, fax, courier, etc.) will incur a manual order charge. All OSS charges are specified in Rate Exhibit B of this Attachment 2.

15.8 Denial/Restoral OSS Charge

- 15.8.3 In the event Heritage provides a list of customers to be denied and restored, rather than an LSR, each location on the list will require a separate PON and, therefore will be billed as one LSR per location.
- 15.9 Cancellation OSS Charge
- 15.9.3 Heritage will incur an OSS charge for an accepted LSR that is later canceled.
- 15.9.4 Supplements or clarifications to a previously billed LSR will not incur another OSS charge.
- 15.9.5 Network Elements and Other Services Manual Additive
- 15.9.5.1 The Commissions in some states have ordered per-element manual additive non-recurring charges (NRC) for Network Elements and Other Services ordered by means other than one of the interactive interfaces. These ordered Network Elements and Other Services manual additive NRCs will apply in these states, rather than the charge per LSR. The per-element charges are listed on the Rate Tables in Exhibit B.

EXHIBIT A

**LINE INFORMATION DATA BASE (LIDB)
FACILITIES BASED STORAGE AGREEMENT**

I. Definitions

- A. Billing number - a number that Heritage creates for the purpose of identifying an account liable for charges. This number may be a line or a special billing number.
- B. Line number - a ten digit number that identifies a telephone line administered by Heritage.
- C. Special billing number - a ten-digit number that identifies a billing account established by Heritage.
- D. Calling Card number - a billing number plus PIN number.
- E. PIN number - a four-digit security code assigned by Heritage that is added to a billing number to compose a fourteen-digit calling card number.
- F. Toll billing exception indicator - associated with a billing number to indicate that it is considered invalid for billing of collect calls or third number calls or both, by Heritage.
- G. Billed Number Screening - refers to the activity of determining whether a toll billing exception indicator is present for a particular billing number.
- H. Calling Card Validation - refers to the activity of determining whether a particular calling card number exists as stated or otherwise provided by a caller.
- I. Billing number information - information about billing number, Calling Card number and toll billing exception indicator provided to BellSouth by Heritage.

II. General

- A. This Agreement sets forth the terms and conditions pursuant to which BellSouth agrees to store in its LIDB certain information at the request of Heritage and pursuant to which BellSouth, its LIDB customers and Heritage shall have access to such information. In addition, this Agreement sets forth the terms and conditions for Heritage's provision of billing number information to BellSouth for inclusion in BellSouth's LIDB. Heritage understands that BellSouth provides access to information in its LIDB to various telecommunications service providers pursuant to applicable tariffs and agrees that information stored at the request of Heritage, pursuant to this Agreement, shall be available to those telecommunications service providers. The terms and conditions contained herein shall hereby be made a part of this Interconnection Agreement upon notice to Heritage's account team to activate

this LIDB Storage Agreement. The General Terms and Conditions of the Interconnection/Resale Agreement shall govern this LIDB Storage Agreement.

B. BellSouth will provide responses to on-line, call-by-call queries to billing number information for the following purposes:

1. Billed Number Screening

BellSouth is authorized to use the billing number information to determine whether Heritage has identified the billing number as one that should not be billed for collect or third number calls.

2. Calling Card Validation

BellSouth is authorized to validate a 14-digit Calling Card number where the first 10 digits are a line number or special billing number assigned by BellSouth and where the last four digits (PIN) are a security code assigned by BellSouth.

3. Fraud Control

BellSouth will provide seven days per week, 24-hours per day, fraud monitoring on Calling Cards, bill-to-third and collect calls made to numbers in BellSouth's LIDB, provided that such information is included in the LIDB query. BellSouth will establish fraud alert thresholds and will notify Heritage of fraud alerts so that Heritage may take action it deems appropriate.

III. Responsibilities of the Parties

A. BellSouth will administer all data stored in the LIDB, including the data provided by Heritage pursuant to this Agreement, in the same manner as BellSouth's data for BellSouth's end user customers. BellSouth shall not be responsible to Heritage for any lost revenue which may result from BellSouth's administration of the LIDB pursuant to its established practices and procedures as they exist and as they may be changed by BellSouth in its sole discretion from time to time.

B. Billing and Collection Customers

BellSouth currently has in effect numerous billing and collection agreements with various interexchange carriers and billing clearinghouses and as such these billing and collection customers ("B&C Customers") query BellSouth's LIDB to determine whether to accept various billing options from end users. Until such time as BellSouth implements in its LIDB and its supporting systems the means to differentiate Heritage's data from BellSouth's data, the following terms and conditions shall apply:

1. Heritage will accept responsibility for telecommunications services billed by BellSouth for its B&C Customers for Heritage's End User accounts which are resident in LIDB pursuant to this Agreement. Heritage authorizes BellSouth to

place such charges on Heritage's bill from BellSouth and shall pay all such charges including, but not limited to, collect and third number calls.

2. Charges for such services shall appear on a separate BellSouth bill page identified with the name of the B&C Customers for which BellSouth is billing the charge.
3. Heritage shall have the responsibility to render a billing statement to its End Users for these charges, but Heritage shall pay BellSouth for the charges billed regardless of whether Heritage collects from Heritage's End Users.
4. BellSouth shall have no obligation to become involved in any disputes between Heritage and B&C Customers. BellSouth will not issue adjustments for charges billed on behalf of any B&C Customer to Heritage. It shall be the responsibility of Heritage and the B&C Customers to negotiate and arrange for any appropriate adjustments.

C. SPNP Arrangements

1. BellSouth will include billing number information associated with exchange lines or SPNP arrangements in its LIDB. Heritage will request any toll billing exceptions via the Local Service Request (LSR) form used to order exchange lines, or the SPNP service request form used to order SPNP arrangements.
2. Under normal operating conditions, BellSouth shall include the billing number information in its LIDB upon completion of the service order establishing either the local exchange service or the SPNP arrangement, provided that BellSouth shall not be held responsible for any delay or failure in performance to the extent such delay or failure is caused by circumstances or conditions beyond BellSouth's reasonable control. BellSouth will store in its LIDB an unlimited volume of the working telephone numbers associated with either the local exchange lines or the SPNP arrangements. For local exchange lines or for SPNP arrangements, BellSouth will issue line-based calling cards only in the name of Heritage. BellSouth will not issue line-based calling cards in the name of Heritage's individual End Users. In the event that Heritage wants to include calling card numbers assigned by Heritage in the BellSouth LIDB, a separate agreement is required.

V. Fees for Service and Taxes

- A. Heritage will not be charged a fee for storage services provided by BellSouth to Heritage, as described in this LIDB Facilities Based Storage Agreement.
- B. Sales, use and all other taxes (excluding taxes on BellSouth's income) determined by BellSouth or any taxing authority to be due to any federal, state or local taxing jurisdiction with respect to the provision of the service set forth herein will be paid by Heritage in accordance with the tax provisions set forth in the General Terms and Conditions of this Agreement.

Unbundled Network Elements
FLORIDA

CATEGORY	NOTES	UNBUNDLED NETWORK ELEMENT				RATES (\$)					OSS RATES (\$)				
		Interim	Zone	SCS	UROC	Rate	Post	Adst	Post	Adst	SCS/C	SCS/B	SCS/R	SCS/W	SCS/S
<p>The "Zone" shown in the sections for stand-alone loops or loops as part of a combination refers to Geographically Deleveraged UNE Zones. To view Geographically Deleveraged UNE Zone Designations by Central Office, refer to Internet Website http://www.interconnection.bellsouth.com/become_a_clec/html/interconnection.htm</p>															
UNBUNDLED EXCHANGE ACCESS LOOP															
2-WIRE ANALOG VOICE GRADE LOOP															
	2-Wire Analog Voice Grade Loop - Service Level 1- Zone 1	1	UEANL	UEAL2	11.74	44.66	20.57	23.1	5.92					10.73	1.85
	2-Wire Analog Voice Grade Loop - Service Level 1- Zone 2	2	UEANL	UEAL2	18.26	44.66	20.57	23.1	5.92					10.73	1.85
	2-Wire Analog Voice Grade Loop - Service Level 1- Zone 3	3	UEANL	UEAL2	30.75	44.66	20.57	23.1	5.92					10.73	1.85
	2-Wire Analog Voice Grade Loop-Service Level 1-Line Splitting- Zone 1	1	UEPSR, UEPSB	UEALS	11.74	44.66	20.57	23.1	5.92					10.73	1.85
	2-Wire Analog Voice Grade Loop-Service Level 1-Line Splitting- Zone 2	2	UEPSR, UEPSB	UEALS	18.26	44.66	20.57	23.1	5.92					10.73	1.85
	2-Wire Analog Voice Grade Loop-Service Level 1-Line Splitting- Zone 3	3	UEPSR, UEPSB	UEALS	30.75	44.66	20.57	23.1	5.92					10.73	1.85
	Engineering Information Document (EID)		UEAL			29.77	28.77								
	Manual Order Coordination for UML-SL 1s (per loop)		UEANL	UEAMC		8.12	8.12								
	Order Coordination for Specified Conversion Time for UML-SL 1 (per LSR)		UEANL	OCOSL		20.75	20.75								
	2-Wire Analog Voice Grade Loop - Service Level 2 w/Loop or Ground Start Signaling - Zone 1	1	UEA	UEAL2	13.43	122.38	74.35	57.28	10.83					10.73	1.85
	2-Wire Analog Voice Grade Loop - Service Level 2 w/Loop or Ground Start Signaling - Zone 2	2	UEA	UEAL2	18.6	122.38	74.35	57.28	10.83					10.73	1.85
	2-Wire Analog Voice Grade Loop - Service Level 2 w/Loop or Ground Start Signaling - Zone 3	3	UEA	UEAL2	35.18	122.38	74.35	57.28	10.83					10.73	1.85
	Order Coordination for Specified Conversion Time (per LSR)		UEA	OCOSL		20.75									
	2-Wire Analog Voice Grade Loop - Service Level 2 w/Reverse Battery Signaling - Zone 1	1	UEA	UEAR2	13.43	122.38	74.35	57.28	10.83					10.73	1.85
	2-Wire Analog Voice Grade Loop - Service Level 2 w/Reverse Battery Signaling - Zone 2	2	UEA	UEAR2	18.6	122.38	74.35	57.28	10.83					10.73	1.85
	2-Wire Analog Voice Grade Loop - Service Level 2 w/Reverse Battery Signaling - Zone 3	3	UEA	UEAR2	35.18	122.38	74.35	57.28	10.83					10.73	1.85
	Order Coordination for Specified Conversion Time (per LSR)		UEA	OCOSL		20.75									
4-WIRE ANALOG VOICE GRADE LOOP															
	4-Wire Analog Voice Grade Loop - Zone 1	1	UEA	UEAL4	21.23	161.34	103.62	80.47	14.02					10.73	1.85
	4-Wire Analog Voice Grade Loop - Zone 2	2	UEA	UEAL4	28.31	161.34	103.62	80.47	14.02					10.73	1.85
	4-Wire Analog Voice Grade Loop - Zone 3	3	UEA	UEAL4	55.63	161.34	103.62	80.47	14.02					10.73	1.85
	Order Coordination for Specified Conversion Time (per LSR)		UEA	OCOSL		20.75									
2-WIRE ISDN DIGITAL GRADE LOOP															
	2-Wire ISDN Digital Grade Loop - Zone 1	1	UDN	UHL2X	26.44	133.15	85.12	56.1	9.65					10.73	1.85
	2-Wire ISDN Digital Grade Loop - Zone 2	2	UDN	UHL2X	28.37	133.15	85.12	56.1	9.65					10.73	1.85
	2-Wire ISDN Digital Grade Loop - Zone 3	3	UDN	UHL2X	63.56	133.15	85.12	56.1	9.65					10.73	1.85
	Order Coordination For Specified Conversion Time (per LSR)		UDN	OCOSL		20.75									
2-WIRE Universal Digital Channel (UDC) COMPATIBLE LOOP															
	2-Wire Universal Digital Channel (UDC) Compatible Loop - Zone 1	1	UDC	UDC2X	20.44	133.15	85.12	56.1	9.65					10.73	1.85
	2-Wire Universal Digital Channel (UDC) Compatible Loop - Zone 2	2	UDC	UDC2X	28.31	133.15	85.12	56.1	9.65					10.73	1.85
	2-Wire Universal Digital Channel (UDC) Compatible Loop - Zone 3	3	UDC	UDC2X	63.56	133.15	85.12	56.1	9.65					10.73	1.85
2-WIRE ASYMMETRICAL DIGITAL SUBSCRIBER LINE (ADSL) COMPATIBLE LOOP															
	2-Wire Unbundled ADSL Loop including manual service inquiry & facility reservation - Zone 1	1	UAL	UAL2X	11.52	134.8	83.62	67.66	14.09					10.73	1.85
	2-Wire Unbundled ADSL Loop including manual service inquiry & facility reservation - Zone 2	2	UAL	UAL2X	15.96	134.8	83.62	67.66	14.09					10.73	1.85
	2-Wire Unbundled ADSL Loop including manual service inquiry & facility reservation - Zone 3	3	UAL	UAL2X	30.19	134.8	83.62	67.66	14.09					10.73	1.85
	Order Coordination for Specified Conversion Time (per LSR)		UAL	OCOSL		20.75									
	2-Wire Unbundled ADSL Loop without manual service inquiry & facility reservation - Zone 1	1	UAL	UAL2W	11.52	112.55	84.12	54.67	8.22					10.73	1.85
	2-Wire Unbundled ADSL Loop without manual service inquiry & facility reservation - Zone 2	2	UAL	UAL2W	15.96	112.55	84.12	54.67	8.22					10.73	1.85
	2-Wire Unbundled ADSL Loop without manual service inquiry & facility reservation - Zone 3	3	UAL	UAL2W	30.19	112.55	84.12	54.67	8.22					10.73	1.85

Unbundled Network Elements
FLORIDA

	Order Coordination for Specified Conversion Time (per LSR)		UHL	OCOSL		20.75							
2-WIRE HIGH BIT RATE DIGITAL SUBSCRIBER LINE (HDSL) COMPATIBLE LOOP													
2-WIRE HIGH BIT RATE DIGITAL SUBSCRIBER LINE (HDSL) COMPATIBLE LOOP													
	2 Wire Unbundled HDSL Loop including manual service inquiry & facility reservation - Zone 1	1	UHL	UHL2X	9.12	143.43	102.25	67.66	14.09	10.73			1.66
	2 Wire Unbundled HDSL Loop including manual service inquiry & facility reservation - Zone 2	2	UHL	UHL2X	12.63	143.43	102.25	67.66	14.09	10.73			1.66
	2 Wire Unbundled HDSL Loop including manual service inquiry & facility reservation - Zone 3	3	UHL	UHL2X	23.9	143.43	102.25	67.66	14.09	10.73			1.66
Order Coordination for Specified Conversion Time (per LSR)													
	2 Wire Unbundled HDSL Loop without manual service inquiry and facility reservation - Zone 1	1	UHL	UHL2W	9.12	121.17	72.75	54.67	8.22	10.73			1.66
	2 Wire Unbundled HDSL Loop without manual service inquiry and facility reservation - Zone 2	2	UHL	UHL2W	12.63	121.17	72.75	54.67	8.22	10.73			1.66
	2 Wire Unbundled HDSL Loop without manual service inquiry and facility reservation - Zone 3	3	UHL	UHL2W	23.9	121.17	72.75	54.67	8.22	10.73			1.66
Order Coordination for Specified Conversion Time (per LSR)													
4-WIRE HIGH BIT RATE DIGITAL SUBSCRIBER LINE (HDSL) COMPATIBLE LOOP													
4-Wire Unbundled HDSL Loop including manual service inquiry and facility reservation - Zone 1													
	4-Wire Unbundled HDSL Loop including manual service inquiry and facility reservation - Zone 2	2	UHL	UHL4X	14.24	174.28	125.3	69.56	11.37	10.73			1.66
	4-Wire Unbundled HDSL Loop including manual service inquiry and facility reservation - Zone 3	3	UHL	UHL4X	37.31	174.28	125.3	69.56	11.37	10.73			1.66
Order Coordination for Specified Conversion Time (per LSR)													
	4-Wire Unbundled HDSL Loop without manual service inquiry and facility reservation - Zone 1	1	UHL	UHL4W	14.24	152.02	104.11	56.57	10.12	10.73			1.66
	4-Wire Unbundled HDSL Loop without manual service inquiry and facility reservation - Zone 2	2	UHL	UHL4W	19.72	152.02	104.11	56.57	10.12	10.73			1.66
	4-Wire Unbundled HDSL Loop without manual service inquiry and facility reservation - Zone 3	3	UHL	UHL4W	37.31	152.02	104.11	56.57	10.12	10.73			1.66
Order Coordination for Specified Conversion Time (per LSR)													
4-WIRE DS1 DIGITAL LOOP													
	4-Wire DS1 Digital Loop - Zone 1	1	USL	USLXX	69.22	262.15	163.51	47.4	10.22	10.73			1.66
	4-Wire DS1 Digital Loop - Zone 2	2	USL	USLXX	95.69	262.15	163.51	47.4	10.22	10.73			1.66
	4-Wire DS1 Digital Loop - Zone 3	3	USL	USLXX	181.36	262.15	163.51	47.4	10.22	10.73			1.66
Order Coordination for Specified Conversion Time (per LSR)													
4-WIRE 19.2, 56 OR 64 Kbps DIGITAL GRADE LOOP													
	4 Wire Unbundled Digital 19.2 Kbps	1	UDL	UDL19	24.48	145.66	98.14	60.47	14.02	10.73			1.66
	4 Wire Unbundled Digital 19.2 Kbps	2	UDL	UDL19	33.91	145.66	98.14	60.47	14.02	10.73			1.66
	4 Wire Unbundled Digital 19.2 Kbps	3	UDL	UDL19	64.14	145.66	98.14	60.47	14.02	10.73			1.66
	4 Wire Unbundled Digital Loop 56 Kbps - Zone 1	1	UDL	UDL56	24.48	145.66	98.14	60.47	14.02	10.73			1.66
	4 Wire Unbundled Digital Loop 56 Kbps - Zone 2	2	UDL	UDL56	33.91	145.66	98.14	60.47	14.02	10.73			1.66
	4 Wire Unbundled Digital Loop 56 Kbps - Zone 3	3	UDL	UDL56	64.14	145.66	98.14	60.47	14.02	10.73			1.66
Order Coordination for Specified Conversion Time (per LSR)													
	4 Wire Unbundled Digital Loop 64 Kbps - Zone 1	1	UDL	UDL64	24.48	145.66	98.14	60.47	14.02	10.73			1.66
	4 Wire Unbundled Digital Loop 64 Kbps - Zone 2	2	UDL	UDL64	33.91	145.66	98.14	60.47	14.02	10.73			1.66
	4 Wire Unbundled Digital Loop 64 Kbps - Zone 3	3	UDL	UDL64	64.14	145.66	98.14	60.47	14.02	10.73			1.66
Order Coordination for Specified Conversion Time (per LSR)													
2-WIRE UNBUNDLED COPPER LOOP													
	2-Wire Unbundled Copper Loop/Short including manual service inquiry & facility reservation - Zone 1	1	UCL	UCLPB	11.52	133.66	92.7	67.66	14.09	10.73			1.66
	2-Wire Unbundled Copper Loop/Short including manual service inquiry & facility reservation - Zone 2	2	UCL	UCLPB	15.96	133.66	92.7	67.66	14.09	10.73			1.66
	2-Wire Unbundled Copper Loop/Short including manual service inquiry & facility reservation - Zone 3	3	UCL	UCLPB	30.19	133.66	92.7	67.66	14.09	10.73			1.66
Order Coordination for Unbundled Copper Loops (per loop)													
	2-Wire Unbundled Copper Loop/Short without manual service inquiry and facility reservation - Zone 1	1	UCL	UCLPW	11.52	111.62	63.19	54.67	8.22	10.73			1.66
	2-Wire Unbundled Copper Loop/Short without manual service inquiry and facility reservation - Zone 2	2	UCL	UCLPW	15.96	111.62	63.19	54.67	8.22	10.73			1.66
	2-Wire Unbundled Copper Loop/Short without manual service inquiry and facility reservation - Zone 3	3	UCL	UCLPW	30.19	111.62	63.19	54.67	8.22	10.73			1.66
Order Coordination for Unbundled Copper Loops (per loop)													
			UCL	UCLMC		8.12	8.12						

Unbundled Network Elements
FLORIDA

Line Sharing - per Line Activation		ULB	ULBDC	0.61	40	22				10.73		1.65
Line Sharing - per Subsequent Activity per Line Rearrangement		ULS	ULSDS		30	15				10.73		
UNBUNDLED TRANSPORT												
COMMON TRANSPORT (Shared)												
Common Transport - Per Mile, Per MOU				0.0000039								
Common Transport - Facilities Termination Per MOU				0.0004579								
NOTE: INTEROFFICE CHANNEL - DEDICATED TRANSPORT - minimum billing period - below DS3 - one month, DS3 and above four months												
INTEROFFICE CHANNEL - DEDICATED TRANSPORT - VOICE GRADE												
Interoffice Channel - Dedicated Transport - 2-Wire Voice Grade - Per Mile per month		U1TVX	1L5XX	0.0084								
Interoffice Channel - Dedicated Transport - 2-Wire Voice Grade - Facility Termination per month		U1TVX	U1TV2	26.02	42.88	28.86	16.51	6.34		10.73		1.65
Interoffice Channel - Dedicated Transport - 2-Wire Voice Grade Rev Bat - Per Mile per month		U1TVX	1L5XX	0.0084								
Interoffice Channel - Dedicated Transport - 2-Wire Vd Rev Bat - Facility Termination per month		U1TVX	U1TR2	26.02	42.88	28.86	16.51	6.34		10.73		1.65
Interoffice Channel - Dedicated Transport - 4-Wire Voice Grade - Per Mile per month		U1TVX	1L5XX	0.0084								
Interoffice Channel - Dedicated Transport - 4-Wire Voice Grade - Facility Termination per month		U1TVX	U1TV4	23.2	42.88	28.86	16.51	6.34		10.73		1.65
Interoffice Channel - Dedicated Transport - 56 Mbps - per mile per month		U1TDX	1L5XX	0.0084								
Interoffice Channel - Dedicated Transport - 56 Mbps - Facility Termination per month		U1TDX	U1TD6	18.95	42.88	28.86	16.51	6.34		10.73		1.65
Interoffice Channel - Dedicated Transport - 64 Mbps - per mile per month		U1TDX	1L5XX	0.0084								
Interoffice Channel - Dedicated Transport - 64 Mbps - Facility Termination per month		U1TDX	U1TD6	18.95	42.88	28.86	16.51	6.34		10.73		1.65
INTEROFFICE CHANNEL - DEDICATED TRANSPORT - DS1												
Interoffice Channel - Dedicated Channel - DS1 - Per Mile per month		U1TD1	1L5XX	0.171								
Interoffice Channel - Dedicated Transport - DS1 - Facility Termination per month		U1TD1	U1TF1	90.87	96.16	89.78	16.74	14.85		10.73		1.65
INTEROFFICE CHANNEL - DEDICATED TRANSPORT - DS3												
Interoffice Channel - Dedicated Transport - DS3 - Per Mile per month		U1TR3	1L5XX	3.57								
Interoffice Channel - Dedicated Transport - DS3 - Facility Termination per month		U1TR3	U1TF3	1101	302.43	187.7	64.84	63.61		10.73		1.65
INTEROFFICE CHANNEL - DEDICATED TRANSPORT - STS-1												
Interoffice Channel - Dedicated Transport - STS-1 - Per Mile per month		U1TS1	1L5XX	3.57								
Interoffice Channel - Dedicated Transport - STS-1 - Facility Termination per month		U1TS1	U1TF5	1066	302.43	187.7	64.84	63.61		10.73		1.65
LOCAL CHANNEL - DEDICATED TRANSPORT												
NOTE: LOCAL CHANNEL DEDICATED TRANSPORT - minimum billing period - below DS3-one month, DS3 and above four months												
Local Channel - Dedicated - 2-Wire Voice Grade per month - Zone 1	1	ULCVX	ULDV2	21.04	238.67	42.34	33.93	3.61		10.73		1.65
Local Channel - Dedicated - 2-Wire Voice Grade per month - Zone 2	2	ULCVX	ULDV2	29.15	238.67	42.34	33.93	3.61		10.73		1.65
Local Channel - Dedicated - 2-Wire Voice Grade per month - Zone 3	3	ULCVX	ULDV2	58.14	238.67	42.34	33.93	3.61		10.73		1.65
Local Channel - Dedicated - 2-Wire Voice Grade Rev. Bat. Per month - Zone 1	1	ULCVX	ULDV2	21.04	238.67	42.34	33.93	3.61		10.73		1.65
Local Channel - Dedicated - 2-Wire Voice Grade Rev. Bat. Per Month - Zone 2	2	ULCVX	ULDV2	29.15	238.67	42.34	33.93	3.61		10.73		1.65
Local Channel - Dedicated - 2-Wire Voice Grade Rev. Bat. Per Month - Zone 3	3	ULCVX	ULDV2	58.14	238.67	42.34	33.93	3.61		10.73		1.65
Local Channel - Dedicated - 4-Wire Voice Grade per month - Zone 1	1	ULCVX	ULDV4	21.91	240.3	42.97	34.47	4.15		10.73		1.65
Local Channel - Dedicated - 4-Wire Voice Grade per month - Zone 2	2	ULCVX	ULDV4	30.36	240.3	42.97	34.47	4.15		10.73		1.65
Local Channel - Dedicated - 4-Wire Voice Grade per month - Zone 3	3	ULCVX	ULDV4	57.4	240.3	42.97	34.47	4.15		10.73		1.65
Local Channel - Dedicated - DS1 per month - Zone 1	1	ULD01	ULD01	34.49	195.33	185.48	21.9	15.28		10.73		1.65
Local Channel - Dedicated - DS1 per month - Zone 2	2	ULD01	ULD01	47.73	195.33	185.48	21.9	15.28		10.73		1.65
Local Channel - Dedicated - DS1 per month - Zone 3	3	ULD01	ULD01	90.38	195.33	185.48	21.9	15.28		10.73		1.65
Local Channel - Dedicated - DS3 - Per Mile per month		ULD03	1L5NC	7.83								
Local Channel - Dedicated - DS3 - Facility Termination per month		ULD03	ULD03	554.83	501.59	309.24	125.43	87.3		10.73		1.65
Local Channel - Dedicated - STS-1 - Per Mile per month		ULD01	1L6NC	7.83								
Local Channel - Dedicated - STS-1 - Facility Termination per month		ULD01	ULD01	583.73	501.59	309.24	125.43	87.3		10.73		1.65
MULTIPLERS												
Channelization - DS1 to DS0 Channel System		UKT01	MO1	151.74	81.44	64.57	10	9.46		10.73		1.65
OC3/DF COC (4-wire) - DS1 to DS0 Channel System - per month (2.4-44Mbps)		UDL	1D15D	2.18								
2-wire (SON COC) (8MTS) - DS1 to DS0 Channel System - per month		UDL	UC1CA	3.78								
Voice Grade COC - DS1 to DS0 Channel System - per month		UEA	1D1V6	1.42								
DS3 to DS1 Channel System per month		UKT03	MO3	218.7	179.68	106.96	36.37	35.22		10.73		1.65
STS1 to DS1 Channel System per month		UKT01	MO1	218.7	179.68	106.96	36.37	35.22		10.73		1.65
DS3 Interface Unit (DS1 COC) used with Loop per month		USL	UC101	14.24								
DARK FIBER												
Dark Fiber, Four Fiber Strands, Per Route Mile or Fraction Thereof per month - Local Channel		UDF	1L5DC	54.11								
NRC Dark Fiber - Local Channel		UDF	UDFC4		677.34	174.79	277.72	179.41		10.73		1.65
Dark Fiber, Four Fiber Strands, Per Route Mile or Fraction Thereof per month - Interoffice Channel		UDF	1L5DF	28.14								
NRC Dark Fiber - Interoffice Channel		UDF	UDF14		677.34	174.79	277.72	179.41		10.73		1.65
Dark Fiber, Four Fiber Strands Per Route Mile or Fraction Thereof per month - Local Loop		UDF	1L5DL	54.11								

Unbundled Network Elements
FLORIDA

	NRFC Dark Fiber - Local Loop		UDF	UDFL4	677.34	174.79	277.72	179.41	10.73		1.65
TRANSPORT OTHER											
Optional Features & Functions:											
	Clear Channel Capability (BB2S/SSF) Option - Subsequent - per DS1 Channel		LINC1X	CCOEF	184.82	23.82	2.07	0.8	10.73		1.65
	Clear Channel Capability (BB2S/SSF) Option - Subsequent - per DS1 Channel		LINC1X	CCOSF	184.82	23.82	2.07	0.8	10.73		1.65
8XX ACCESS TEN DIGIT SCREENING											
	8XX Access Ten Digit Screening, Per Call		OH4		0.0006185						
	8XX Access Ten Digit Screening, Reservation Charge Per 8XX Number Reserved		OH4	NR11X	3.74	0.84			10.73		1.65
	8XX Access Ten Digit Screening, Per 8XX No. Established W/O POTS		OH4		7.82	1.08	5.2	0.64			1.65
	8XX Access Ten Digit Screening, Per 8XX No. Established With POTS		OH4	NRFTX	7.82	1.08	5.2	0.64			1.65
	8XX Access Ten Digit Screening, Customized Area of Service Per 8XX Number		OH4	NRFCDX	3.74	1.87			10.73		1.65
	8XX Access Ten Digit Screening, Multiple Intra-LATA CXR Routing Per CXR Requested Per 8XX No.		OH4	NRFMCX	4.37	2.5			10.73		1.65
	8XX Access Ten Digit Screening, Change Charge Per Request		OH4	NRFAX	4.37	0.84			10.73		1.65
	8XX Access Ten Digit Screening, Call Handling and Destination Features		OH4	NRFCDX	3.74				10.73		1.65
	8XX Access Ten Digit Screening, w/ 8XX No. Delivery, per query		OH4		0.0006185						
	8XX Access Ten Digit Screening, w/ POTS No. Delivery, per query		OH4		0.0006185						
LINE INFORMATION DATA BASE ACCESS (LIDB)											
	LIDB Common Transport Per Query		OO1		0.0000185						
	LIDB Validation Per Query		OO1		0.0132254						
	LIDB Originating Point Code Establishment or Change		OO1, OCU	NRFBX	48.71	48.71	48.71	48.71	10.73		1.65
SIGNALLING (CCS7)											
	CCS7 Signaling Termination, Per STP Port		1DB	PT8SX	128.77				10.73		1.65
	CCS7 Signaling Usage, Per TCAP Message		1DB		0.0000692						
	CCS7 Signaling Connection, Per link (A link)		1DB	YPP++	18.39	39.28	39.28	18.51	18.51	10.73	1.65
	CCS7 Signaling Connection, Per link (B link) (also known as D link)		1DB	YPP++	18.39	39.28	39.28	18.51	18.51	10.73	1.65
	CCS7 Signaling Usage, Per ISUP Message		1DB		0.0000748						
	CCS7 Signaling Usage Surrogate, per link per LATA		1DB	STU5B	678.89				10.73		1.65
	CCS7 Signaling Point Code, per Originating Point Code Establishment or Change, per STP affected		1DB	CCAPQ	41.5	41.5			10.73		1.65
	CCS7 Signaling Point Code, per Destination Point Code Establishment or Change, Per Stp Affected		1DB	CCAPD	8	8			10.73		1.65
E911 SERVICE											
	Local Channel - Dedicated - 2-wr Voice Grade - Zone 1				21.04	239.67	42.34	33.93	3.81	10.73	1.65
	Local Channel - Dedicated - 2-wr Voice Grade - Zone 2				29.15	239.67	42.34	33.93	3.81	10.73	1.65
	Local Channel - Dedicated - 2-wr Voice Grade - Zone 3				66.14	239.67	42.34	33.93	3.81	10.73	1.65
	Interoffice Transport - Dedicated - 2-wr Voice Grade Per Mile				0.0084						
	Interoffice Transport - Dedicated - 2-wr Voice Grade Per Facility Termination				26.02	42.69	28.68	16.51	8.34	10.73	1.65
	Local Channel - Dedicated - DS1 - Zone 1				34.49	185.33	185.48	21.9	15.28	10.73	1.65
	Local Channel - Dedicated - DS1 - Zone 2				47.78	185.33	185.48	21.9	15.28	10.73	1.65
	Local Channel - Dedicated - DS1 - Zone 3				90.38	185.33	185.48	21.9	15.28	10.73	1.65
	Interoffice Transport - Dedicated - DS1 Per Mile				0.171						
	Interoffice Transport - Dedicated - DS1 Per Facility Termination				80.67	85.18	88.78	16.74	14.86	10.73	1.65
CALLING NAME (CNAM) SERVICE											
	CNAM for DB Owners, Per Query		OOV		0.0010181						
	CNAM for Non DB Owners, Per Query		OOV		0.0010181						
	CNAM For DB Owners - Service Establishment		OOV		22.85	22.85	17.14	17.14	10.73		1.65
	CNAM For Non DB Owners - Service Establishment		OOV		22.85	22.85	17.14	17.14	10.73		1.65
	CNAM For DB Owners - Service Provisioning With Point Code Establishment		OOV		1435	1081	317.7	233.6	10.73		1.65
	CNAM For Non DB Owners - Service Provisioning With Point Code Establishment		OOV		492.73	368.07	322.83	253.6	10.73		1.65
	CNAM (non-Database Owner), NRFC, applies when using the Character Based User Interface (CHUI)		OOV	CDDCH	688	886			10.73		1.65
LNP QUERY SERVICE											
	LNP Query Per Query				0.000842						
	LNP Service Establishment Manual				12.48	12.48	9.35	9.35	10.73		1.65
	LNP Service Provisioning with Point Code Establishment				591.01	301.83	218.42	180.6	10.73		1.65
OPERATOR SERVICES AND DIRECTORY ASSISTANCE											
OPERATOR CALL PROCESSING											
	Oper. Call Processing - Oper. Provided, Per Min. - Using BST LIDB				1.2						
	Oper. Call Processing - Oper. Provided, Per Min. - Using Foreign LIDB				1.24						
	Oper. Call Processing - Fully Automated, per Call - Using BST LIDB				0.2						
	Oper. Call Processing - Fully Automated, per Call - Using Foreign LIDB				0.2						
INWARD OPERATOR SERVICES											
	Inward Operator Services - Verification, Per Call				1						
	Inward Operator Services - Verification and Emergency Intercept - Per Call				1.85						

BRANDING - OPERATOR CALL PROCESSING												
	Recording of Custom Branded OA Announcement			CBAOS	7000	7000					10.73	1.88
	Loading of Custom Branded OA Announcement per shelf/NAV			CBAOL	500	500					10.73	
DIRECTORY ASSISTANCE SERVICES												
DIRECTORY ASSISTANCE ACCESS SERVICE												
	Directory Assistance Access Service Calls, Charge Per Call				0.275							
DIRECTORY ASSISTANCE CALL COMPLETION ACCESS SERVICE (DIACC)												
	Directory Assistance Call Completion Access Service (DIACC), Per Call Attempt				0.1							
UNBRANDING												
DIRECTORY TRANSPORT												
	Directory Transport - Local Channel DS1				43.84	242.45	228.44				10.73	1.88
	Directory Transport - DS1 Level Interoffice Per Mile				0.8013							
	Directory Transport - DS1 Level Interoffice Per Facility Termination				86.79	45.91	44.18				10.73	1.88
	Switched Common Transport Per DA Access Service Per Call				0.0003							
	Switched Common Transport Per DA Access Service Per Call Per Mile				0.00001							
	Access Tandem Switching Per DA Access Service Per Call				0.00055							
	Directory Transport - Installation NRC, Per Trunk or Signaling Connection					208.08	4.71				10.73	1.88
DIRECTORY ASSISTANCE DATA BASE SERVICE (DADS)												
	Directory Assistance Data Base Service Charge Per Listing				0.04							
	Directory Assistance Data Base Service, per month			DBSOF	150							
BRANDING - DIRECTORY ASSISTANCE												
	Custom Branding Announcement, per Recording to be used with the provision of DA		AMT	CBADA	3000	3000						
	Loading of Custom Branded Announcement per DRAM Card/Switch		AMT	CBADC	690	690						
SELECTIVE ROUTING												
	Selective Routing Per Unique Line Class Code Per Request Per Switch			USRCR	84.33	84.33	11.48	11.48			10.73	1.88
VIRTUAL COLLOCATION												
	Virtual Collocation - 2-wire Cross Connects (loop)	uanl,ueu,udr,ucb:		UEAC2	0.0297	33.88	31.95				10.73	1.88
	Virtual Collocation-2 Wire Cross Connects (Loop) for Line Splitting	uepsr,uepsb		VE1L8	0.0297	33.88	31.95				10.73	1.88
	Virtual Collocation - 2-wire Cross Connects (port)			VE1P2	0.0502	11.57	11.57				10.73	1.88
	Virtual Collocation - 4-wire Cross Connects (loop)	ueu,uh,uel,udl		UEAC4	0.0594	33.89	32				10.73	1.88
	Virtual Collocation - 4-wire Cross Connects (port)			VE1P4	0.0592	11.57	11.57				10.73	1.88
	Virtual Collocation - DS1 Cross Connects	U5L,U1C,CLO		CR1X	1.37	53.3	40.2					
AIN SELECTIVE CARRIER ROUTING												
	Regional Service Establishment		SRC	SRCEC		191575	8974				10.73	1.88
	End Office Establishment		SRC	SRCEO		168.89	168.89	0.63	0.63		10.73	1.88
	Query NRC, per query		SRC		0.0030996							
AIN - BELLSOUTH AIN SMS ACCESS SERVICE												
	AIN SMS Access Service - Service Establishment, Per State, Initial Setup			CAMSE	39.27	39.27	33.04	33.04			10.73	1.88
	AIN SMS Access Service - Port Connection - Dial/Shared Access			CAMPD	7.79	7.79	7.38	7.38			10.73	1.88
	AIN SMS Access Service - Port Connection - tSDN Access			CAMPF	7.79	7.79	7.38	7.38			10.73	1.88
	AIN SMS Access Service - User Identification Codes - Per User ID Code			CAMAU	34.85	34.85	21.97	21.97			10.73	1.88
	AIN SMS Access Service - Security Card, Per User ID Code, Initial or Replacement			CAMRC	73.76	73.76	9.51	9.51			10.73	1.88
	AIN SMS Access Service - Storage, Per Unit (100 Kilobytes)				0.0029							
	AIN SMS Access Service - Session, Per Minute				0.7985							
	AIN SMS Access Service - Company Performed Session, Per Minute				0.4155							
AIN - BELLSOUTH AIN TOOLKIT SERVICE												
	AIN Toolkit Service - Service Establishment Charge, Per State, Initial Setup			BAPSC	39.27	39.27	33.04	33.04			10.73	1.88
	AIN Toolkit Service - Training Session, Per Customer			BAPVX	8405	8405					10.73	1.88
	AIN Toolkit Service - Trigger Access Charge, Per Trigger, Per DN, Term. Attempt			BAPT1	7.79	7.79	7.38	7.38			10.73	1.88
	AIN Toolkit Service - Trigger Access Charge, Per Trigger, Per DN, Off-Hook Delay			BAPFD	7.79	7.79	7.38	7.38			10.73	1.88
	AIN Toolkit Service - Trigger Access Charge, Per Trigger, Per DN, Off-Hook Immediate			BAPTM	7.79	7.79	7.38	7.38			10.73	1.88
	AIN Toolkit Service - Trigger Access Charge, Per Trigger, Per DN, 10-Digit PODP			BAPTO	34.32	34.32	11.66	11.66			10.73	1.88
	AIN Toolkit Service - Trigger Access Charge, Per Trigger, Per DN, CDP			BAPTC	34.32	34.32	11.66	11.66			10.73	1.88
	AIN Toolkit Service - Trigger Access Charge, Per Trigger, Per DN, Feature Code			BAPTF	34.32	34.32	11.66	11.66			10.73	1.88
	AIN Toolkit Service - Query Charge, Per Query				0.0509436							
	AIN Toolkit Service - Type 1 Node Charge, Per AIN Toolkit Subscription, Per Node, Per Query				0.0082787							
	AIN Toolkit Service - SCP Storage Charge, Per SMS Access Account, Per 100 Kilobytes				0.08							
	AIN Toolkit Service - Monthly report - Per AIN Toolkit Service Subscription			BAPMS	8	7.79	7.79	4.47	4.47		10.73	1.88

Unbundled Network Elements
FLORIDA

Attachment 2
Sheet C

		AIN Toolkit Service - Special Study - Per AIN Toolkit Service Subscription			BAPLS	3.85	8.62	8.62				10.73		1.66
		AIN Toolkit Service - Call Event Report - Per AIN Toolkit Service Subscription			BAPDS	4.28	7.79	7.79	4.47	4.47		10.73		1.66
		AIN Toolkit Service - Call Event Special Study - Per AIN Toolkit Service			BAPES	0.13	8.62	8.62				10.73		1.66
ODUF/EDOU/ADUF/CMD5														
ACCESS DAILY USAGE FILE (ADUF)														
		ADUF: Message Processing, per message				0.013528								
		ADUF: Data Transmission (CONNECT/DIRECT), per message				0.00012927								
ENHANCED OPTIONAL DAILY USAGE FILE (EODUF)														
		EODUF: Message Processing, per message				0.222451								
OPTIONAL DAILY USAGE FILE (ODUF)														
		ODUF: Recording, per message				0.0000098								
		ODUF: Message Processing, per message				0.006614								
		ODUF: Message Processing, per Magnetic Tape provisioned				48.77								
		ODUF: Data Transmission (CONNECT/DIRECT), per message				0.00010772								
ENHANCED EXTENDED LINK (EELs)														
NOTE: New EELs available in State of Georgia, density zone 1 of following SMAs: Orlando, FL; Miami, FL; Ft. Lauderdale, FL; Nashville, TN; New Orleans, LA;														
NOTE: Charlotte-Gastonia-Rockhill, NC; Greensboro-Winston Salem-High Point, NC. Use all rates below except Switch As Is Charge.														
NOTE: In all states, EEL network elements shown below also apply to currently combined facilities which are converted to UNE rates. A Switch As Is Charge applies to currently combined facilities converted to UNEs (Non-recurring rates do not apply.)														
NOTE: In Georgia, the EEL network elements apply to originally combined network elements per the GA PSC order (No Switch As Is Charge.)														
2-WIRE VOICE GRADE EXTENDED LOOP WITH DEDICATED DS1 INTEROFFICE TRANSPORT (EEL)														
		First 2-Wire VG Loop(SL2) in a DS1 Interoffice Transport Combination - Zone 1	1		UNCVX	UEAL2	13.43	115.02	54.58	43.28	5.68	10.73		1.66
		First 2-Wire VG Grade Loop(SL2) in a DS1 Interoffice Transport Combination - Zone 2	2		UNCVX	UEAL2	18.8	115.02	54.58	43.28	5.68	10.73		1.66
		First 2-Wire VG Grade Loop(SL2) in a DS1 Interoffice Transport Combination - Zone 3	3		UNCVX	UEAL2	35.18	115.02	54.58	43.28	5.68	10.73		1.66
		Interoffice Transport - Dedicated - DS1 combination - Per Mile per Month			UNCIX	1LSXX	0.171							
		Interoffice Transport - Dedicated - DS1 combination - Facility Termination per Month			UNCIX	U1TF1	90.87	157.3	110.42	41.12	16.18	10.73		1.66
		DS1 Channelization System Per Month			UNCIX	M01	151.74	61.83	13.29	1.35	1.21			
		Voice Grade COCI - DS1 to DS0 Interface - Per Month			UNCVX	1D1VG	1.42	6.05	4.36					
		Each Additional 2-Wire VG Loop(SL 2) in the same DS1 Interoffice Transport Combination - Zone 1	1		UNCVX	UEAL2	13.43	115.02	54.58	43.28	5.68	10.73		1.66
		Each Additional 2-Wire VG Loop(SL2) in the same DS1 Interoffice Transport Combination - Zone 2	2		UNCVX	UEAL2	18.8	115.02	54.58	43.28	5.68	10.73		1.66
		Each Additional 2-Wire VG Loop(SL2) in the same DS1 Interoffice Transport Combination - Zone 3	3		UNCVX	UEAL2	35.18	115.02	54.58	43.28	5.68	10.73		1.66
		Voice Grade COCI - DS1 to DS0 Channel System combination - per month			UNCVX	1D1VG	1.42	6.05	4.36					
		Nonrecurring Currently Combined Network Elements Switch -As-Is Charge			UNCIX	UNCOO		8.1	8.1	8.1	8.1	10.73		1.66
4-WIRE VOICE GRADE EXTENDED LOOP WITH DEDICATED DS1 INTEROFFICE TRANSPORT (EEL)														
		First 4-Wire Analog Voice Grade Loop in a DS1 Interoffice Transport Combination - Zone 1	1		UNCVX	UEAL4	21.23	115.02	54.58	43.28	5.68	10.73		1.66
		First 4-Wire Analog Voice Grade Loop in a DS1 Interoffice Transport Combination - Zone 2	2		UNCVX	UEAL4	29.41	115.02	54.58	43.28	5.68	10.73		1.66
		First 4-Wire Analog Voice Grade Loop in a DS1 Interoffice Transport Combination - Zone 3	3		UNCVX	UEAL4	55.83	115.02	54.58	43.28	5.68	10.73		1.66
		Interoffice Transport - Dedicated - DS1 combination - Per Mile Per Month			UNCIX	1LSXX	0.171							
		Interoffice Transport - Dedicated - DS1 - Facility Termination Per Month			UNCIX	U1TF1	90.87	157.3	110.42	41.12	16.18	10.73		1.66
		Channelization - Channel System DS1 to DS0 combination Per Month			UNCIX	M01	151.74	61.83	13.29	1.35	1.21			
		Voice Grade COCI - DS1 to DS0 Channel System combination - per month			UNCVX	1D1VG	1.42	6.05	4.36					
		Additional 4-Wire Analog Voice Grade Loop in same DS1 Interoffice Transport Combination - Zone 1	1		UNCVX	UEAL4	21.23	115.02	54.58	43.28	5.68	10.73		1.66
		Additional 4-Wire Analog Voice Grade Loop in same DS1 Interoffice Transport Combination - Zone 2	2		UNCVX	UEAL4	29.41	115.02	54.58	43.28	5.68	10.73		1.66
		Additional 4-Wire Analog Voice Grade Loop in same DS1 Interoffice Transport Combination - Zone 3	3		UNCVX	UEAL4	55.83	115.02	54.58	43.28	5.68	10.73		1.66
		Voice Grade COCI - DS1 to DS0 Channel System combination - per month			UNCVX	1D1VG	1.42	6.05	4.36					
		Nonrecurring Currently Combined Network Elements Switch -As-Is Charge			UNCIX	UNCOO		8.1	8.1	8.1	8.1	10.73		1.66
4-WIRE 56 Kbps EXTENDED DIGITAL LOOP WITH DEDICATED DS1 INTEROFFICE TRANSPORT (EEL)														
		First 4-Wire 56Kbps Digital Grade Loop in a DS1 Interoffice Transport Combination - Zone 1	1		UNCDX	UDL56	24.48	115.02	54.58	43.28	5.68	10.73		1.66
		First 4-Wire 56Kbps Digital Grade Loop in a DS1 Interoffice Transport Combination - Zone 2	2		UNCDX	UDL56	33.91	115.02	54.58	43.28	5.68	10.73		1.66
		First 4-Wire 56Kbps Digital Grade Loop in a DS1 Interoffice Transport Combination - Zone 3	3		UNCDX	UDL56	64.14	115.02	54.58	43.28	5.68	10.73		1.66
		Interoffice Transport - Dedicated - DS1 combination - Per Mile Per Month			UNCIX	1LSXX	0.171							
		Interoffice Transport - Dedicated - DS1 - combination Facility Termination Per Month			UNCIX	U1TF1	90.87	157.3	110.42	41.12	16.18	10.73		1.66
		Channelization - Channel System DS1 to DS0 combination Per Month			UNCIX	M01	151.74	61.83	13.29	1.35	1.21			
		OC/LDP COCI (data) - DS1 to DS0 Channel System - per month (2.4-84kb)			UNCDX	1D1DD	2.16	6.05	4.36					
		Additional 4-Wire 56Kbps Digital Grade Loop in same DS1 Interoffice Transport Combination - Zone 1	1		UNCDX	UDL56	24.48	115.02	54.58	43.28	5.68	10.73		1.66

Unbundled Network Elements
FLORIDA

	Additional 4-Wire 56Kbps Digital Grade Loop in same DS1 Interoffice Transport Combination - Zone 2	2	UNCDX	UDL56	33.91	115.02	54.58	43.28	5.88	10.73	1.65
	Additional 4-Wire 56Kbps Digital Grade Loop in same DS1 Interoffice Transport Combination - Zone 3	3	UNCDX	UDL56	64.14	115.02	54.58	43.28	5.88	10.73	1.65
	OCU-DP COCI (data) - DS1 to DS0 Channel System - combination per month (2 4-64Kbps)		UNCDX	1D1DD	2.16	9.08	6.38				
	Nonrecurring Currently Combined Network Elements Switch -As-Is Charge		UNC1X	UNCCO		8.1	8.1	8.1	8.1	10.73	1.65
	4-WIRE 64 Kbps EXTENDED DIGITAL LOOP WITH DEDICATED DS1 INTEROFFICE TRANSPORT (EEL)										
	First 4-Wire 64Kbps Digital Grade Loop in a DS1 Interoffice Transport Combination - Zone 1	1	UNCDX	UDL64	24.48	115.02	54.58	43.28	5.88	10.73	1.65
	First 4-Wire 64Kbps Digital Grade Loop in a DS1 Interoffice Transport Combination - Zone 2	2	UNCDX	UDL64	33.91	115.02	54.58	43.28	5.88	10.73	1.65
	First 4-Wire 64Kbps Digital Grade Loop in a DS1 Interoffice Transport Combination - Zone 3	3	UNCDX	UDL64	64.14	115.02	54.58	43.28	5.88	10.73	1.65
	Interoffice Transport - Dedicated - DS1 combination - Per Mile Per Month		UNC1X	1LSXX	0.177						
	Interoffice Transport - Dedicated - DS1 combination - Facility Termination Per Month		UNC1X	UITF1	90.87	157.3	110.42	41.12	16.18	10.73	1.65
	Channelization - Channel System DS1 to DS0 combination Per Month		UNC1X	MOI	161.74	51.83	13.29	1.36	1.21		
	OCU-DP COCI (data) - DS1 to DS0 Channel System combination - per month (2 4-64Kbps)		UNCDX	1D1DD	2.16	9.05	4.38				
	Additional 4-Wire 64Kbps Digital Grade Loop in same DS1 Interoffice Transport Combination - Zone 1	1	UNCDX	UDL64	24.48	115.02	54.58	43.28	5.88	10.73	1.65
	Additional 4-Wire 64Kbps Digital Grade Loop in same DS1 Interoffice Transport Combination - Zone 2	2	UNCDX	UDL64	33.91	115.02	54.58	43.28	5.88	10.73	1.65
	Additional 4-Wire 64Kbps Digital Grade Loop in same DS1 Interoffice Transport Combination - Zone 3	3	UNCDX	UDL64	64.14	115.02	54.58	43.28	5.88	10.73	1.65
	OCU-DP COCI (data) - DS1 to DS0 Channel System combination - per month (2 4-64Kbps)		UNCDX	1D1DD	2.16	9.05	4.38				
	Nonrecurring Currently Combined Network Elements Switch -As-Is Charge		UNC1X	UNCCO		8.1	8.1	8.1	8.1	10.73	1.65
	4-WIRE DS1 DIGITAL EXTENDED LOOP WITH DEDICATED DS1 INTEROFFICE TRANSPORT (EEL)										
	4-Wire DS1 Digital Loop in Combination with DS1 Interoffice Transport - Zone 1	1	UNC1X	USLXX	69.22	198.32	109.65	48.38	13.03	10.73	1.65
	4-Wire DS1 Digital Loop in Combination with DS1 Interoffice Transport - Zone 2	2	UNC1X	USLXX	95.69	198.32	109.65	48.38	13.03	10.73	1.65
	4-Wire DS1 Digital Loop in Combination with DS1 Interoffice Transport - Zone 3	3	UNC1X	USLXX	181.38	198.32	109.65	48.38	13.03	10.73	1.65
	Interoffice Transport - Dedicated - DS1 combination - Per Mile Per Month		UNC1X	1LSXX	0.171						
	Interoffice Transport - Dedicated - DS1 combination - Facility Termination Per Month		UNC1X	UITF1	90.87	157.3	110.42	41.12	16.18	10.73	1.65
	Nonrecurring Currently Combined Network Elements Switch -As-Is Charge		UNC1X	UNCCO		8.1	8.1	8.1	8.1	10.73	1.65
	4-WIRE DS1 DIGITAL EXTENDED LOOP WITH DEDICATED DS3 INTEROFFICE TRANSPORT (EEL)										
	First DS1 Loop in DS3 Interoffice Transport Combination - Zone 1	1	UNC1X	USLXX	69.22	198.32	109.65	48.38	13.03	10.73	1.65
	First DS1 Loop in DS3 Interoffice Transport Combination - Zone 2	2	UNC1X	USLXX	95.69	198.32	109.65	48.38	13.03	10.73	1.65
	First DS1 Loop in DS3 Interoffice Transport Combination - Zone 3	3	UNC1X	USLXX	181.38	198.32	109.65	48.38	13.03	10.73	1.65
	Interoffice Transport - Dedicated - DS3 combination - Per Mile Per Month		UNC3X	1LSXX	3.47						
	Interoffice Transport - Dedicated - DS3 - Facility Termination per month		UNC3X	UITF3	1101	298.5	124.61	34.8	16.88	10.73	1.65
	DS3 to DS1 Channel System combination per month		UNC3X	MOI	218.7	104.13	50.98	10.98	3.84		
	DS3 Interface Unit (DS1 COCI) combination per month		UNC1X	UC1D1	14.24	6.05	4.38				
	Additional DS1 Loop in DS3 Interoffice Transport Combination - Zone 1	1	UNC1X	USLXX	69.22	198.32	109.65	48.38	13.03	10.73	1.65
	Additional DS1 Loop in DS3 Interoffice Transport Combination - Zone 2	2	UNC1X	USLXX	95.69	198.32	109.65	48.38	13.03	10.73	1.65
	Additional DS1 Loop in DS3 Interoffice Transport Combination - Zone 3	3	UNC1X	USLXX	181.38	198.32	109.65	48.38	13.03	10.73	1.65
	DS3 Interface Unit (DS1 COCI) combination per month		UNC1X	UC1D1	14.24	6.05	4.38				
	Nonrecurring Currently Combined Network Elements Switch -As-Is Charge		UNC3X	UNCCO		8.1	8.1	8.1	8.1	10.73	1.65
	2-WIRE VOICE GRADE EXTENDED LOOP/ 2 WIRE VOICE GRADE INTEROFFICE TRANSPORT (EEL)										
	2-Wire VG Loop used with 2-wire VG Interoffice Transport Combination - Zone 1	1	UNCVX	UEAL2	13.43	115.02	54.58	43.28	5.88	10.73	1.65
	2-Wire VG Loop used with 2-wire VG Interoffice Transport Combination - Zone 2	2	UNCVX	UEAL2	18.0	115.02	54.58	43.28	5.88	10.73	1.65
	2-Wire VG Loop used with 2-wire VG Interoffice Transport Combination - Zone 3	3	UNCVX	UEAL2	35.18	115.02	54.58	43.28	5.88	10.73	1.65
	Interoffice Transport - Dedicated - 2-wire VG combination - Per Mile Per Month		UNCVX	1LSXX	0.0084						
	Interoffice Transport - Dedicated - 2-Wire Voice Grade combination - Facility Termination per month		UNCVX	UITV2	29.02	85.38	47.42	40.82	18.25	10.73	1.65
	Nonrecurring Currently Combined Network Elements Switch -As-Is Charge		UNCVX	UNCCO		8.1	8.1	8.1	8.1	10.73	1.65
	4-WIRE VOICE GRADE EXTENDED LOOP/ 4 WIRE VOICE GRADE INTEROFFICE TRANSPORT (EEL)										
	4-Wire VG Loop used with 4-wire VG Interoffice Transport Combination - Zone 1	1	UNCVX	UEAL4	21.23	115.02	54.58	43.28	5.88	10.73	1.65
	4-Wire VG Loop used with 4-wire VG Interoffice Transport Combination - Zone 2	2	UNCVX	UEAL4	29.41	115.02	54.58	43.28	5.88	10.73	1.65
	4-Wire VG Loop used with 4-wire VG Interoffice Transport Combination - Zone 3	3	UNCVX	UEAL4	55.63	115.02	54.58	43.28	5.88	10.73	1.65
	Interoffice Transport - Dedicated - 4-wire VG combination - Per Mile Per Month		UNCVX	1LSXX	0.0084						
	Interoffice Transport - Dedicated - 4-Wire Voice Grade combination - Facility Termination per month		UNCVX	UITV4	23.2	85.38	47.42	40.82	18.25	10.73	1.65
	Nonrecurring Currently Combined Network Elements Switch -As-Is Charge		UNCVX	UNCCO		8.1	8.1	8.1	8.1	10.73	1.65
	DS3 DIGITAL EXTENDED LOOP WITH DEDICATED DS3 INTEROFFICE TRANSPORT (EEL)										
	High Capacity Unbundled Local Loop - DS3 combination - Per Mile per month		UNC3X	1LSHD	10.06						
	High Capacity Unbundled Local Loop - DS3 combination - Facility Termination per month		UNC3X	UE3PX	387.1	220.38	139.5	60.49	23.89		

Unbundled Network Elements
FLORIDA

	Interoffice Transport - Dedicated - DS3 - Per Mile per month		UNCSX	1L50X	3.57							
	Interoffice Transport - Dedicated - DS3 combination - Facility Termination per month		UNCSX	U1TF3	1101	288.5	124.81	34.8	16.96		10.73	1.65
	Nonrecurring Currently Combined Network Elements Switch -As-Is Charge		UNCSX	UNCCC		8.1	8.1	8.1	8.1		10.73	1.65
	STS1 DIGITAL EXTENDED LOOP WITH DEDICATED STS1 INTEROFFICE TRANSPORT (EEL)											
	High Capacity Unbundled Local Loop - STS1 combination - Per Mile per month		UNCSX	1LEND	10.08							
	High Capacity Unbundled Local Loop - STS1 combination - Facility Termination per month		UNCSX	UDLS1	428.66	220.36	139.5	60.49	23.69			
	Interoffice Transport - Dedicated - STS1 combination - Per Mile per month		UNCSX	1L50X	3.57							
	Interoffice Transport - Dedicated - STS1 combination - Facility Termination per month		UNCSX	U1TF3	1085	288.5	124.81	34.8	16.96		10.73	1.65
	Nonrecurring Currently Combined Network Elements Switch -As-Is Charge		UNCSX	UNCCC		8.1	8.1	8.1	8.1		10.73	1.65
	2-WIRE IDSN EXTENDED LOOP WITH DS1 INTEROFFICE TRANSPORT (EEL)											
	First 2-Wire IDSN Loop in a DS1 Interoffice Combination Transport - Zone 1	1	UNCNK	U1L2X	20.44	115.02	54.58	43.26	5.66		10.73	1.65
	First 2-Wire IDSN Loop in a DS1 Interoffice Combination Transport - Zone 2	2	UNCNK	U1L2X	28.31	115.02	54.58	43.26	5.66		10.73	1.65
	First 2-Wire IDSN Loop in a DS1 Interoffice Combination Transport - Zone 3	3	UNCNK	U1L2X	53.56	115.02	54.58	43.26	5.66		10.73	1.65
	Interoffice Transport - Dedicated - DS1 combination - Per Mile		UNCNK	1L50X	0.171							
	Interoffice Transport - Dedicated - DS1 combination - Facility Termination per month		UNCNK	U1TF1	80.87	167.3	110.42	41.12	16.18		10.73	1.65
	Channelization - Channel System DS1 to DSO combination - per month		UNCNK	MD1	151.74	51.83	13.29	1.35	1.21			
	2-wire IDSN COC (BRITE) - DS1 to DSO Channel System combination - per month		UNCNK	UC1CA	3.76	6.05	4.36					
	Additional 2-wire IDSN Loop in same DS1 Interoffice Transport Combination - Zone 1	1	UNCNK	U1L2X	20.44	115.02	54.58	43.26	5.66		10.73	1.65
	Additional 2-wire IDSN Loop in same DS1 Interoffice Transport Combination - Zone 2	2	UNCNK	U1L2X	28.31	115.02	54.58	43.26	5.66		10.73	1.65
	Additional 2-wire IDSN Loop in same DS1 Interoffice Transport Combination - Zone 3	3	UNCNK	U1L2X	53.56	115.02	54.58	43.26	5.66		10.73	1.65
	2-wire IDSN COC (BRITE) - DS1 to DSO Channel System combination - per month		UNCNK	UC1CA	3.76	6.05	4.36					
	Nonrecurring Currently Combined Network Elements Switch -As-Is Charge		UNCNK	UNCCC		8.1	8.1	8.1	8.1		10.73	1.65
	4-WIRE DS1 DIGITAL EXTENDED LOOP WITH DEDICATED STS-1 INTEROFFICE TRANSPORT (EEL)											
	First DS1 Loop in STS1 Interoffice Transport Combination - Zone 1	1	UNCNK	USLJX	69.22	198.32	109.65	48.38	13.03		10.73	1.65
	First DS1 Loop in STS1 Interoffice Transport Combination - Zone 2	2	UNCNK	USLJX	85.89	198.32	109.65	48.38	13.03		10.73	1.65
	First DS1 Loop in STS1 Interoffice Transport Combination - Zone 3	3	UNCNK	USLJX	181.38	198.32	109.65	48.38	13.03		10.73	1.65
	Interoffice Transport - Dedicated - STS1 combination - Per Mile Per Month		UNCSX	1L50X	3.57							
	Interoffice Transport - Dedicated - STS1 combination - Facility Termination		UNCSX	U1TF5	1085	288.5	124.81	34.8	16.96		10.73	1.65
	STS1 to DS1 Channel System combination per month		UNCSX	MD3	218.7							
	DS3 Interface Unit (DS1 COC) combination per month		UNCNK	UC1D1	14.24	6.05	4.36					
	Additional DS1 Loop in STS1 Interoffice Transport Combination - Zone 1	1	UNCNK	USLJX	69.22	198.32	109.65	48.38	13.03		10.73	1.65
	Additional DS1 Loop in STS1 Interoffice Transport Combination - Zone 2	2	UNCNK	USLJX	85.89	198.32	109.65	48.38	13.03		10.73	1.65
	Additional DS1 Loop in STS1 Interoffice Transport Combination - Zone 3	3	UNCNK	USLJX	181.38	198.32	109.65	48.38	13.03		10.73	1.65
	DS3 Interface Unit (DS1 COC) combination per month		UNCNK	UC1D1	14.24	6.05	4.36					
	Nonrecurring Currently Combined Network Elements Switch -As-Is Charge		UNCSX	UNCCC		8.1	8.1	8.1	8.1		10.73	1.65
	4-WIRE 56 KBPS DIGITAL EXTENDED LOOP WITH 56 KBPS INTEROFFICE TRANSPORT (EEL)											
	4-wire 56 Kbps Loop/4-wire 56 Kbps Interoffice Transport Combination - Zone 1	1	UNCDX	UDL56	24.48	115.02	54.58	43.26	5.66		10.73	1.65
	4-wire 56 Kbps Loop/4-wire 56 Kbps Interoffice Transport Combination - Zone 2	2	UNCDX	UDL56	33.91	115.02	54.58	43.26	5.66		10.73	1.65
	4-wire 56 Kbps Loop/4-wire 56 Kbps Interoffice Transport Combination - Zone 3	3	UNCDX	UDL56	64.14	115.02	54.58	43.26	5.66		10.73	1.65
	Interoffice Transport - Dedicated - 4-wire 56 Kbps combination - Per Mile		UNCDX	1L50X	0.0088							
	Interoffice Transport - Dedicated - 4-wire 56 Kbps combination - Facility		UNCDX	U1TDS	19.31	85.38	47.42	40.82	16.25		10.73	1.65
	Nonrecurring Currently Combined Network Elements Switch -As-Is Charge		UNCDX	UNCCC		8.1	8.1	8.1	8.1		10.73	1.65
	4-WIRE 64 KBPS DIGITAL EXTENDED LOOP WITH 64 KBPS INTEROFFICE TRANSPORT (EEL)											
	4-wire 64 Kbps Loop/4-wire 64 Kbps Interoffice Transport Combination - Zone 1	1	UNCDX	UDL64	24.48	115.02	54.58	43.26	5.66		10.73	1.65
	4-wire 64 Kbps Loop/4-wire 64 Kbps Interoffice Transport Combination - Zone 2	2	UNCDX	UDL64	33.91	115.02	54.58	43.26	5.66		10.73	1.65
	4-wire 64 Kbps Loop/4-wire 64 Kbps Interoffice Transport Combination - Zone 3	3	UNCDX	UDL64	64.14	115.02	54.58	43.26	5.66		10.73	1.65
	Interoffice Transport - Dedicated - 4-wire 64 Kbps combination - Per Mile		UNCDX	1L50X	0.0088							
	Interoffice Transport - Dedicated - 4-wire 64 Kbps combination - Facility		UNCDX	U1TDS	19.31	149.56	86	71.35	31.97		10.73	1.65
	Nonrecurring Currently Combined Network Elements Switch -As-Is Charge		UNCDX	UNCCC		8.1	8.1	8.1	8.1		10.73	1.65
	ADDITIONAL NETWORK ELEMENTS											
	When used as a part of a currently combined facility, the non-recurring charges do not apply, but a Switch As Is charge does apply.											
	When used as ordinary combined network elements in Georgia, the non-recurring charges apply and the Switch As Is Charge does not.											
	Node (Synchronous)											
	Node per month		UNCDX	UNCNT	16.35							
	Nonrecurring Currently Combined Network Elements "Switch As Is" Charge (One applies to each combination)											
	2/4-Wire VG Interoffice Channel used in a COMBINATION - "Switch As Is" Conversion Charge		UNCVX	UNCCC		8.1	8.1	8.1	8.1		10.73	1.65
	66/84 Kbps Interoffice Channel used in a COMBINATION - "Switch As Is" Conversion Charge		UNCDX	UNCCC		8.1	8.1	8.1	8.1		10.73	1.65

Unbundled Network Elements
FLORIDA

	DS1 Interoffice Channel used in a COMBINATION - "Switch As Is" Conversion Charge	UNC1X	UNCOO		8.1	8.1	8.1	8.1	10.73	1.65
	DS3 Interoffice Channel used in a COMBINATION - "Switch As Is" Conversion Charge	UNC3X	UNCOO		8.1	8.1	8.1	8.1	10.73	1.65
	STS1 Interoffice or Local Loop used in a COMBINATION - "Switch As Is" Conversion Charge	UNC5X	UNCOO		8.1	8.1	8.1	8.1	10.73	1.65
	NOTE: Local Channel - Dedicated Transport - minimum billing period - Below DS3=one month, DS3 and above=four months									
OPERATIONAL SUPPORT SYSTEMS										
	NOTE: (1) Electronic Service Order: CLEC-1 should contact its contract negotiator if it prefers the state specific electronic service ordering charges as ordered by the State Commission									
	NOTE: (1) Continued: The electronic service ordering charge currently contained in this rate exhibit is the BellSouth regional electronic service ordering charge									
	NOTE: (1) Concluded: CLEC-1 may elect either the state specific Commission ordered rates for the electronic service ordering charges, or CLEC-1 may elect the regional electronic service ordering charge.									
	NOTE: (2) Manual Service Order charge - disconnect, in the state of Florida, to be billed on a per LSR basis									
	Electronic OSS Charge per LSR, submitted via BST's OSS interactive interfaces (Regional)			SOME C					3.6	
	The "Zone" shown in the sections for stand-alone loops or loops as part of a combination refers to Geographically Deleveraged LINE Zones. To view Geographically Deleveraged LINE Zone Designations by Central Office, refer to Internet Website: http://www.interconnection.bellsouth.com/become_a_clec/html/interconnection.htm									
UNBUNDLED LOCAL EXCHANGE SWITCHING (PORTS)										
	Exchange Ports									
	NOTE: Although the Port Rates include all available features in GA & TN, the desired features will need to be ordered using retail USOCs									
	2-WIRE VOICE GRADE LINE PORT RATES (RES)									
	Exchange Ports - 2-Wire Analog Line Port - Res.	UEPSR	UEPRL	1.34	3.37	3.27	1.69	1.62	10.73	1.65
	Exchange Ports - 2-Wire Analog Line Port with Caller ID - Res.	UEPSR	UEPRC	1.34	3.37	3.27	1.69	1.62	10.73	1.65
	Exchange Ports - 2-Wire Analog Line Port outgoing only - Res.	UEPSR	UEPRO	1.34	3.37	3.27	1.69	1.62	10.73	1.65
	Exchange Ports - 2-Wire VG unbundled Florida area calling with Caller ID - Res	UEPSR	UEPAF	1.34	3.37	3.27	1.69	1.62	10.73	1.65
	Exchange Ports - 2-Wire VG unbundled res, low usage line port with Caller ID	UEPSR	UEPAP	1.34	3.37	3.27	1.69	1.62	10.73	1.65
	Subsequent Activity	UEPSR	USASC	0	0	0				
	All Available Vertical Features	UEPSR	UEPVF	2.17	0	0			10.73	1.65
	2-WIRE VOICE GRADE LINE PORT RATES (BUS)									
	Exchange Ports - 2-Wire Analog Line Port without Caller ID - Bus	UEPSB	UEPBL	1.34	3.37	3.27	1.69	1.62	10.73	1.65
	Exchange Ports - 2-Wire VG unbundled Line Port with unbundled port with Caller+E484 ID - Bus.	UEPSB	UEPBC	1.34	3.37	3.27	1.69	1.62	10.73	1.65
	Exchange Ports - 2-Wire Analog Line Port outgoing only - Bus	UEPSB	UEPSO	1.34	3.37	3.27	1.69	1.62	10.73	1.65
	Exchange Ports - 2-Wire VG unbundled incoming only port with Caller ID - Bus	UEPSB	UEPB1	1.34	3.37	3.27	1.69	1.62	10.73	1.65
	Subsequent Activity	UEPSB	USASC	0	0	0				
	All Available Vertical Features	UEPSB	UEPVF	2.17	0	0			10.73	1.65
	EXCHANGE PORT RATES (DID & PBX)									
	Exchange Ports - 2-Wire DID Port	UEPEX	UEPP2	8.81	70.69	14.26	37.81	3.84	10.73	1.65
	Exchange Ports - DDITS Port - 4-Wire DS1 Port with DID capability	UEPDD	UEPDD	52.73	136.24	70.1	44	2.8	10.73	1.65
	Exchange Ports - 2-Wire ISDN Port (See Notes below)	UEPTX	UEPSX	3.40	42.22	45.69	24.81	10.75	10.73	1.65
	All Features Offered	UEPTX	UEPSX	2.17	0	0				
	NOTE: Transmission/usage charges associated with POTS circuit switched usage will also apply to circuit switched voice and/or circuit switched data transmission by B-Channels associated with 2-wire ISDN ports.									
	NOTE: Access to B Channel or D Channel Packet capabilities will be available only through BFN/New Business Request Process. Rates for the packet capabilities will be determined via the Form File Request/New Business Request Process.									
	Exchange Ports - 2-Wire ISDN Port - Channel Profiles	UEPTX	UEPSX	0	0	0				
	Exchange Ports - 4-Wire ISDN DS1 Port	UEPEX	UEPEX	79.35	157.42	85.6	44.89	18.43	10.73	1.65
	2-Wire VG Unbundled 2-Way PBX Trunk - Res	UEPSE	UEPRD	1.34	35.22	16.39	11.14	0.648	10.73	1.65
	2-Wire VG Line Side Unbundled 2-Way PBX Trunk - Bus	UEPSP	UEPPC	1.34	35.22	16.39	11.14	0.648	10.73	1.65
	2-Wire VG Line Side Unbundled Outward PBX Trunk - Bus	UEPSP	UEPPO	1.34	35.22	16.39	11.14	0.648	10.73	1.65
	2-Wire VG Line Side Unbundled Incoming PBX Trunk - Bus	UEPSP	UEPPI	1.34	35.22	16.39	11.14	0.648	10.73	1.65
	2-Wire Analog Long Distance Termination PBX Trunk - Bus	UEPSP	UEPLD	1.34	35.22	16.39	11.14	0.648	10.73	1.65
	2-Wire Voice Unbundled PBX LD Terminal Ports	UEPSP	UEPLD	1.34	35.22	16.39	11.14	0.648	10.73	1.65
	2-Wire Voice Unbundled 2-Way PBX Usage Port	UEPSP	UEPXA	1.34	35.22	16.39	11.14	0.648	10.73	1.65
	2-Wire Voice Unbundled PBX Toll Terminal Hotel Ports	UEPSP	UEPXB	1.34	35.22	16.39	11.14	0.648	10.73	1.65
	2-Wire Voice Unbundled PBX LD DOD Terminals Port	UEPSP	UEPXC	1.34	35.22	16.39	11.14	0.648	10.73	1.65
	2-Wire Voice Unbundled PBX LD Terminal Switchboard Port	UEPSP	UEPYD	1.34	35.22	16.39	11.14	0.648	10.73	1.65
	2-Wire Voice Unbundled PBX LD Terminal Switchboard IDD Capable Port	UEPSP	UEPYE	1.34	35.22	16.39	11.14	0.648	10.73	1.65
	2-Wire Voice Unbundled 2-Way PBX Hotel/Hospital Economy Administrative Calling Port	UEPSP	UEPYL	1.34	35.22	16.39	11.14	0.648	10.73	1.65
	2-Wire Voice Unbundled 2-Way PBX Hotel/Hospital Economy Room Calling Port	UEPSP	UEPYM	1.34	35.22	16.39	11.14	0.648	10.73	1.65

Unbundled Network Elements
FLORIDA

Description	Code	Code	Rate	Rate	Rate	Rate	Rate	Rate	Rate	Rate
2-Wire Voice Unbundled 1-Way Outgoing PBX Hotel/Hospital Discount Room Calling Port										
2-Wire Voice Unbundled 1-Way Outgoing PBX Measured Port	UEPSP	UEPXO	1.34	35.22	18.39	11.14	0.648		10.73	1.65
	UEPSP	UEPXS	1.34	35.22	18.39	11.14	0.648		10.73	1.65
Subsequent Activity										
FEATURES										
All Available Vertical Features	UEPSP	USASC	0	0	0					
EXCHANGE PORT RATES (COIN)										
Exchange Ports - Coin Port	UEPSP	UEPSE	1.34	3.27	3.27	1.69	1.62		10.73	1.65
NOTE: Transmission/usage charges associated with POTS circuit switched usage will also apply to circuit switched voice and/or circuit switched data transmission by B-Channels associated with 2-wire ISDN ports.										
NOTE: Access to B Channel or D Channel Packet capabilities will be available only through BFF/New Business Request Process. Rates for the packet capabilities will be determined via the B-Channel Request/New Business Request Process										
UNBUNDLED LOCAL SWITCHING, PORT USAGE										
End Office Switching (Port Usage)										
End Office Switching Function, Per MOU										
End Office Trunk Port - Shared, Per MOU				0.0007341						
				0.0001571						
Tandem Switching (Port Usage) (Local or Access Tandem)										
Tandem Switching Function Per MOU									0.0001283	
Tandem Trunk Port - Shared, Per MOU									0.0002252	
Common Transport										
Common Transport - Per Mile, Per MOU									0.0000034	
Common Transport - Facilities Termination Per MOU									0.0004493	
UNBUNDLED PORT/LOOP COMBINATIONS - COST BASED RATES										
<i>Cost Based Rates are applied where BellSouth is required by FCC and/or State Commission rule to provide Unbundled Local Switching or Switch Ports.</i>										
<i>Features shall apply to the Unbundled Port/Loop Combination - Cost Based Rate section in the same manner as they are applied to the Stand-Alone Unbundled Port section of this Rate Exhibit.</i>										
<i>End Office and Tandem Switching Usage and Common Transport Usage rates in the Port section of this rate exhibit shall apply to all combinations of loop/port network elements except for UNE Coin Port/Loop Combinations.</i>										
<i>For Georgia and Tennessee, the recurring UNE Port and Loop charges listed apply to Currently Combined and Not Currently Combined Combos and the first and additional Port nonrecurring charges apply to Not Currently Combined Combos. For Currently Combined Combos in GA, TN and all other states, the nonrecurring charges shall be those identified in the Nonrecurring - Currently Combined sections.</i>										
2-WIRE VOICE GRADE LOOP WITH 2-WIRE LINE PORT (RES)										
UNE Port/Loop Combination Rates										
2-Wire VG Loop/Port Combo - Zone 1			1						13.01	
2-Wire VG Loop/Port Combo - Zone 2			2						17.15	
2-Wire VG Loop/Port Combo - Zone 3			3						30.45	
UNE Loop Rates										
2-Wire Voice Grade Loop (SL1) - Zone 1		UEPRX	UEPLX	11.89						
2-Wire Voice Grade Loop (SL1) - Zone 2		UEPRX	UEPLX	16.03						
2-Wire Voice Grade Loop (SL1) - Zone 3		UEPRX	UEPLX	29.33						
2-Wire Voice Grade Line Port Rates (Res)										
2-Wire voice unbundled port - residence		UEPRX	UEPRL	1.12					10.73	1.65
2-Wire voice unbundled port with Caller ID - res		UEPRX	UEPRC	1.12					10.73	1.65
2-Wire voice unbundled port outstation only - res		UEPRX	UEPRO	1.12					10.73	1.65
2-Wire voice unbundled Florida Area Calling with Caller ID - res		UEPRX	UEPAF	1.12					10.73	1.65
2-Wire voice unbundled res, low usage line port with Caller ID (LUM)		UEPRX	UEPAP	1.12					10.73	1.65
FEATURES										
All Features Offered	UEPRX	UEPVF	2.17	0	0				10.73	1.65
LOCAL NUMBER PORTABILITY										
Local Number Portability (1 per port)		UEPRX	LNPCX	0.36						
NONRECURRING CHARGES (NRCs) - CURRENTLY COMBINED										
2-Wire Voice Grade Loop / Line Port Combination - Conversion - Switch as-is		UEPRX	USAC2		0.082	0.082			10.73	
2-Wire Voice Grade Loop / Line Port Combination - Conversion - Switch with charge		UEPRX	USACC		0.082	0.082			10.73	
ADDITIONAL NRCs										
2-Wire Voice Grade Loop/Line Port Combination - Subsequent Activity		UEPRX	USAS2	0	0	0				
2-WIRE VOICE GRADE LOOP WITH 2-WIRE LINE PORT (BUS)										
UNE Port/Loop Combination Rates										
2-Wire VG Loop/Port Combo - Zone 1			1						13.01	
2-Wire VG Loop/Port Combo - Zone 2			2						17.15	
2-Wire VG Loop/Port Combo - Zone 3			3						30.45	
UNE Loop Rates										
2-Wire Voice Grade Loop (SL1) - Zone 1		UEPRX	UEPLX	11.89						
2-Wire Voice Grade Loop (SL1) - Zone 2		UEPRX	UEPLX	16.03						

Unbundled Network Elements
FLORIDA

	2-Wire Voice Grade Loop (SL1) - Zone 3	3	UEPBX	UEPLX	29.33							
2-Wire Voice Grade Line Port (Bus)												
	2-Wire voice unbundled port without Caller ID - bus		UEPBX	UEPBL	1.12					10.73		1.05
	2-Wire voice unbundled port with Caller + E494 ID - bus		UEPBX	UEPBC	1.12					10.73		1.05
	2-Wire voice unbundled port outgoing only - bus		UEPBX	UEPBO	1.12					10.73		1.05
	2-Wire voice unbundled incoming only port with Caller ID - Bus		UEPBX	UEPBI	1.12					10.73		1.05
LOCAL NUMBER PORTABILITY												
	Local Number Portability (1 per port)		UEPBX	LNPCX	0.95							
FEATURES												
	All Features Offered		UEPBX	UEPVF	2.17	0	0			10.73		1.05
NONRECURRING CHARGES (NRCs) - CURRENTLY COMBINED												
	2-Wire Voice Grade Loop / Line Port Combination - Conversion - Switch-as-is		UEPBX	USAC2	0.092	0.092				10.73		1.05
	2-Wire Voice Grade Loop / Line Port Combination - Conversion - Switch with change		UEPBX	USACC	0.092	0.092						
ADDITIONAL NRCs												
	2-Wire Voice Grade Loop/Line Port Combination - Subsequent Activity		UEPBX	USAS2						10.73		
2-WIRE VOICE GRADE LOOP WITH 2-WIRE LINE PORT (RES - PBX)												
UNE Port/Loop Combination Rates												
	2-Wire VG Loop/Port Combo - Zone 1	1			13.01							
	2-Wire VG Loop/Port Combo - Zone 2	2			17.15							
	2-Wire VG Loop/Port Combo - Zone 3	3			30.45							
UNE Loop Rates												
	2-Wire Voice Grade Loop (SL 1) - Zone 1	1	UEPRG	UEPLX	11.89							
	2-Wire Voice Grade Loop (SL 1) - Zone 2	2	UEPRG	UEPLX	16.03							
	2-Wire Voice Grade Loop (SL 1) - Zone 3	3	UEPRG	UEPLX	29.33							
2-Wire Voice Grade Line Port Rates (RES - PBX)												
	2-Wire VG Unbundled Combination 2-Way PBX Trunk Port - Res		UEPRG	UEPRD	1.12					10.73		1.05
LOCAL NUMBER PORTABILITY												
	Local Number Portability (1 per port)		UEPRG	LNPCP	3.5							
FEATURES												
	All Features Offered		UEPRG	UEPVF	2.17	0	0			10.73		1.05
NONRECURRING CHARGES (NRCs) - CURRENTLY COMBINED												
	2-Wire Voice Grade Loop/ Line Port Combination (PBX) - Conversion - Switch-As-is		UEPRG	USAC2	7.62	1.72				10.73		
	2-Wire Voice Grade Loop/ Line Port Combination (PBX) - Conversion - Switch with Change		UEPRG	USACC	7.62	1.72				10.73		
ADDITIONAL NRCs												
	2-Wire Voice Grade Loop/ Line Port Combination (PBX) - Subsequent Activity		UEPRG	USAS2	0	0	0					
	PBX Subsequent Activity - Change/Rearrange Multiline Hunt Group					7.09	7.09			10.73		1.05
2-WIRE VOICE GRADE LOOP WITH 2-WIRE LINE PORT (BUS - PBX)												
UNE Port/Loop Combination Rates												
	2-Wire VG Loop/Port Combo - Zone 1	1			13.01							
	2-Wire VG Loop/Port Combo - Zone 2	2			17.15							
	2-Wire VG Loop/Port Combo - Zone 3	3			30.45							
UNE Loop Rates												
	2-Wire Voice Grade Loop (SL 1) - Zone 1	1	UEPPX	UEPLX	11.89							
	2-Wire Voice Grade Loop (SL 1) - Zone 2	2	UEPPX	UEPLX	16.03							
	2-Wire Voice Grade Loop (SL 1) - Zone 3	3	UEPPX	UEPLX	29.33							
2-Wire Voice Grade Line Port Rates (BUS - PBX)												
	Line Side Unbundled Combination 2-Way PBX Trunk Port - Bus		UEPPX	UEPPC	1.12					10.73		1.05
	Line Side Unbundled Outward PBX Trunk Port - Bus		UEPPX	UEPPD	1.12					10.73		1.05
	Line Side Unbundled Incoming PBX Trunk Port - Bus		UEPPX	UEPP1	1.12					10.73		1.05
	2-Wire Voice Unbundled PBX LD Terminal Ports		UEPPX	UEPLD	1.12					10.73		1.05
	2-Wire Voice Unbundled 2-Way Combination PBX Usage Port		UEPPX	UEPXA	1.12					10.73		1.05
	2-Wire Voice Unbundled PBX Toll Terminal Hotel Ports		UEPPX	UEPXB	1.12					10.73		1.05
	2-Wire Voice Unbundled PBX LD DDD Terminal Port		UEPPX	UEPXC	1.12					10.73		1.05
	2-Wire Voice Unbundled PBX LD Terminal Switchboard Port		UEPPX	UEPXD	1.12					10.73		1.05

Unbundled Network Elements
FLORIDA

	2-Wire Voice Unbundled PBX (D Terminal Switchboard IDD Capable Port		UEPPX	UEPXE	1.12					10.73		1.65
	2-Wire Voice Unbundled 2-Way PBX Hotel/Hospital Economy Administrative Calling Port		UEPPX	UEPXL	1.12					10.73		1.65
	2-Wire Voice Unbundled 2-Way PBX Hotel/Hospital Economy Room Calling Port		UEPPX	UEPXM	1.12					10.73		1.65
	2-Wire Voice Unbundled 1-Way Outgoing PBX Hotel/Hospital Discount Room Calling Port		UEPPX	UEPXO	1.12					10.73		1.65
	2-Wire Voice Unbundled 1-Way Outgoing PBX Measured Port		UEPPX	UEPXS	1.12					10.73		1.65
LOCAL NUMBER PORTABILITY												
	Local Number Portability (1 per port)		UEPPX	LNPCP	3.16							
FEATURES												
	All Features Offered		UEPPX	UEPVF	2.17	0	0			10.73		1.65
NONRECURRING CHARGES - CURRENTLY COMBINED												
	2-Wire Voice Grade Loop/Line Port Combination (PBX) - Conversion - Switch-As-Is		UEPPX	USAC2		7.62	1.72			10.73		1.65
	2-Wire Voice Grade Loop/Line Port Combination (PBX) - Conversion - Switch with Change		UEPPX	USACC		7.62	1.72			10.73		1.65
ADDITIONAL NRCS												
	2-Wire Voice Grade Loop/Line Port Combination (PBX) - Subsequent Activity PBX Subsequent Activity - Change/Rearrange Multiple Hunt Group		UEPPX	USAS2	0	0	0			10.73		1.65
2-WIRE VOICE GRADE LOOP WITH 2-WIRE ANALOG LINE COIN PORT												
LINE Port/Loop Combination Rates												
	2-Wire VG Coin Port/Loop Combo - Zone 1					13.01						
	2-Wire VG Coin Port/Loop Combo - Zone 2					17.15						
	2-Wire VG Coin Port/Loop Combo - Zone 3					30.45						
LINE Loop Rates												
	2-Wire Voice Grade Loop (SL1) - Zone 1		UEPCO	UEPLX	11.80							
	2-Wire Voice Grade Loop (SL1) - Zone 2		UEPCO	UEPLX	16.00							
	2-Wire Voice Grade Loop (SL1) - Zone 3		UEPCO	UEPLX	29.33							
2-Wire Voice Grade Line Ports (COIN)												
	2-Wire Coin 2-Way with Operator Screening and Blocking: 011, 900/976, 1+DDD (FL)		UEPCO	UEP2F	1.12					10.73		1.65
	2-Wire Coin 2-Way with Operator Screening and 011 Blocking (FL)		UEPCO	UEPFA	1.12					10.73		1.65
	2-Wire Coin 2-Way with Operator Screening and Blocking: 900/976, 1+DDD, 011+, and Local (FL)		UEPCO	UEPCG	1.12					10.73		1.65
	2-Wire Coin Outward with Operator Screening and 011 Blocking (AL, FL)		UEPCO	UEPPK	1.12					10.73		1.65
	2-Wire Coin Outward with Operator Screening and Blocking: 900/976, 1+DDD, 011+ (FL)		UEPCO	UEPOF	1.12					10.73		1.65
	2-Wire Coin Outward with Operator Screening and Blocking: 900/976, 1+DDD, 011+, and Local (FL, GA)		UEPCO	UEPCO	1.12					10.73		1.65
	2-Wire 2-Way Smartline with 900/976 (all states except LA)		UEPCO	UEPCK	1.12					10.73		1.65
	2-Wire Coin Outward Smartline with 900/976 (all states except LA)		UEPCO	UEPCA	1.12					10.73		1.65
ADDITIONAL LINE COIN PORT/LOOP (PC)												
	LINE Coin Port/Loop Combo Usage (Flat Rate)		UEPCO	URECU	1.60	0	0					
LOCAL NUMBER PORTABILITY												
	Local Number Portability (1 per port)		UEPCO	LNPCP	0.36							
FEATURES												
	All Features Offered		UEPCO	UEPVF	2.17	0	0			10.73		1.65
NONRECURRING CHARGES - CURRENTLY COMBINED												
	2-Wire Voice Grade Loop / Line Port Combination - Conversion - Switch-as-is		UEPCO	USAC2		0.082	0.082			10.73		1.65
	2-Wire Voice Grade Loop / Line Port Combination - Conversion - Switch with change		UEPCO	USACC		0.082	0.082			10.73		1.65
ADDITIONAL NRCS												
	2-Wire Voice Grade Loop/Line Port Combination - Subsequent Activity		UEPCO	USAS2	0	0	0			10.73		1.65
2-WIRE VOICE GRADE LOOP- BUS ONLY - WITH 2-WIRE DID TRUNK PORT												
LINE Port/Loop Combination Rates												
	2-Wire VG Loop/2-Wire DID Trunk Port Combo - LINE Zone 1	1				22.22						
	2-Wire VG Loop/2-Wire DID Trunk Port Combo - LINE Zone 2	2				27.39						
	2-Wire VG Loop/2-Wire DID Trunk Port Combo - LINE Zone 3	3				43.79						
LINE Loop Rates												
	2-Wire Analog Voice Grade Loop - (SL2) - LINE Zone 1	1	UEPPX	UECD1	13.43					10.73		1.65
	2-Wire Analog Voice Grade Loop - (SL2) - LINE Zone 2	2	UEPPX	UECD1	16.8					10.73		1.65
	2-Wire Analog Voice Grade Loop - (SL2) - LINE Zone 3	3	UEPPX	UECD1	35.18					10.73		1.65
LINE Port Rate												
	Exchange Ports - 2-Wire DID Port		UEPPX	UEPD1	6.79					10.73		1.65

Unbundled Network Elements
FLORIDA

NONRECURRING CHARGES - CURRENTLY COMBINED										
2-Wire Voice Grade Loop / 2-Wire DID Trunk Port Combination - Switched at	UEPPX	USAC1		7.08	1.69				10.73	1.65
2-Wire Voice Grade Loop / 2-Wire DID Trunk Port Conversion with BellSouth Allowable Charges	UEPPX	USA1C		7.08	1.69				10.73	1.65
ADDITIONAL NPCCs										
2-Wire DID Subsequent Activity - Add Trunks, Per Trunk	UEPPX	USAS1		29.08	29.08				10.73	1.65
Telephone Number/Trunk Group Establishment Charges										
DID Trunk Termination (One Per Port)	UEPPX	ND1	0	0	0				10.73	1.65
DID Numbers, Establish Trunk Group and Provide First Group of 20 DID Numbers	UEPPX	ND2	0	0	0				10.73	1.65
Additional DID Numbers for each Group of 20 DID Numbers	UEPPX	ND4	0	0	0				10.73	1.65
DID Numbers, Non-consecutive DID Numbers, Per Number	UEPPX	ND6	0	0	0				10.73	1.65
Reserve Non-Consecutive DID numbers	UEPPX	ND8	0	0	0				10.73	1.65
Reserve DID Numbers	UEPPX	NDV	0	0	0				10.73	1.65
LOCAL NUMBER PORTABILITY										
Local Number Portability (1 per port)	UEPPX	LNPCP	3.15							
2-WIRE ISDN DIGITAL GRADE LOOP WITH 2-WIRE ISDN DIGITAL LINE SIDE PORT										
UNE Port/Loop Combination Rates										
2W ISDN Digital Grade Loop/2W ISDN Digital Line Side Port - UNE Zone 1	1	UEPPB		30.29						
2W ISDN Digital Grade Loop/2W ISDN Digital Line Side Port - UNE Zone 2	2	UEPPB		36.51						
2W ISDN Digital Grade Loop/2W ISDN Digital Line Side Port - UNE Zone 3	3	UEPPB		58.45						
UNE Loop Rates										
2-Wire ISDN Digital Grade Loop - UNE Zone 1	1	UEPPB	UEPPR	USL2X	13.43				10.73	1.65
2-Wire ISDN Digital Grade Loop - UNE Zone 2	2	UEPPB	UEPPR	USL2X	29.44				10.73	1.65
2-Wire ISDN Digital Grade Loop - UNE Zone 3	3	UEPPB	UEPPR	USL2X	49.38				10.73	1.65
UNE Port Rate										
Exchange Port - 2-Wire ISDN Line Side Port		UEPPB	UEPPR	UEPPB	7.07				10.73	1.65
NONRECURRING CHARGES - CURRENTLY COMBINED										
2-Wire ISDN Digital Grade Loop / 2-Wire ISDN Line Side Port Combination - Conversion	UEPPB	UEPPR	USACB	0	27.81	15.33			10.73	1.65
ADDITIONAL NPCCs										
LOCAL NUMBER PORTABILITY										
Local Number Portability (1 per port)	UEPPB	UEPPR	LNPCX	0.95	0	0				
B-CHANNEL USER PROFILE ACCESS:										
CVS/CSD (DMS/SESS)	UEPPB	UEPPR	U1UCA	0	0	0				
CVS (EWSO)	UEPPB	UEPPR	U1UCB	0	0	0				
CSD	UEPPB	UEPPR	U1UCC	0	0	0				
B-CHANNEL AREA PLUS USER PROFILE ACCESS: (AL, KY, LA, MS, SC, TN, & TN)										
USER TERMINAL PROFILE										
User Terminal Profile (EWSO only)	UEPPB	UEPPR	U1UMA	0	0	0				
VERTICAL FEATURES										
All Vertical Features - One per Channel B User Profile	UEPPB	UEPPR	UEPVF	2.17	0	0				
INTEROFFICE CHANNEL MILEAGE										
Interoffice Channel mileage each, including first mile and facilities termination	UEPPB	UEPPR	MIGNC	19.79	42.00	28.00	16.51	6.34	10.73	1.65
Interoffice Channel mileage each, additional mile	UEPPB	UEPPR	M	0.0084	0	0			10.73	1.65
4-WIRE DS1 DIGITAL LOOP WITH 4-WIRE ISDN DS1 DIGITAL TRUNK PORT										
UNE Port/Loop Combination Rates										
4W DS1 Digital Loop/4W ISDN DS1 Digital Trunk Port - UNE Zone 1	1	UEPPP		148.57						
4W DS1 Digital Loop/4W ISDN DS1 Digital Trunk Port - UNE Zone 2	2	UEPPP		175.24						
4W DS1 Digital Loop/4W ISDN DS1 Digital Trunk Port - UNE Zone 3	3	UEPPP		260.73						
UNE Loop Rates										

Unbundled Network Elements
FLORIDA

	4-Wire DS1 Digital Loop - UNE Zone 1	1	UEPPP	USL4P	69.22					10.73		1.65
	4-Wire DS1 Digital Loop - UNE Zone 2	2	UEPPP	USL4P	95.89					10.73		1.65
	4-Wire DS1 Digital Loop - UNE Zone 3	3	UEPPP	USL4P	181.38					10.73		1.65
UNE Port Rate												
	Exchange Ports - 4-Wire ISDN DS1 Port		UEPPP	UEPPP	79.35					10.73		1.65
NONRECURRING CHARGES - CURRENTLY COMBINED												
	4-Wire DS1 Digital Loop / 4-Wire ISDN DS1 Digital Trunk Port Combination - Conversion - Switch-as-is		UEPPP	USACP	0	61.25	55.34			10.73		1.65
ADDITIONAL NRCS												
	4-Wire DS1 Loop/4-Wire ISDN Digit Trk Port - Subseqt Actvy- Inward/two way tel nos within Std Allowance		UEPPP	PR7TF		0.4679				10.73		1.65
	4-Wire DS1 Loop / 4-Wire ISDN DS1 Digital Trunk Port - Outward Tel Numbers (All States except NC)		UEPPP	PR7TQ		11.46	11.46			10.73		1.65
	4-Wire DS1 Loop / 4-Wire ISDN DS1 Digital Trk Port - Subsequent Inward Tel Nos Above Std Allowance		UEPPP	PR7ZT		22.82	22.82			10.73		1.65
LOCAL NUMBER PORTABILITY												
	Local Number Portability (1 per port)		UEPPP	UNPCN	1.75							
INTERFACE (Provisioning Only)												
	Voice/Data		UEPPP	PR7IV	0	0	0					
	Digital Data		UEPPP	PR7ID	0	0	0					
	Inward Data		UEPPP	PR7IE	0	0	0					
New or Additional "B" Channel												
	New or Additional - Voice/Data B Channel		UEPPP	PR7BV	0	13.98				10.73		1.65
	New or Additional - Digital Data B Channel		UEPPP	PR7BF	0	13.98				10.73		1.65
	New or Additional Inward Data B Channel		UEPPP	PR7BD	0	13.98				10.73		1.65
	New or Additional Usage Sensitive Voice Data B Channel		UEPPP	PR7BS	0	13.98				10.73		19.99
	New or Additional Usage Sensitive Digital Data B Channel		UEPPP	PR7BU	0	13.98				10.73		1.65
CALL TYPES												
	Inward		UEPPP	PR7CI	0	0	0					
	Outward		UEPPP	PR7CO	0	0	0					
	Two-way		UEPPP	PR7CC	0	0	0					
Interoffice Channel Mileage												
	Fixed Each Including First Mile		UEPPP	1LNIA	91.04	95.15	88.78	16.74	14.85	10.73		1.65
	Each Airline-Fractional Additional Mile		UEPPP	1LNIB	0.171							
4-WIRE DS1 DIGITAL LOOP WITH 4-WIRE DDITS TRUNK PORT												
UNE Port/Loop Combination Rates												
	4W DS1 Digital Loop/4W DDITS Trunk Port - UNE Zone 1	1	UEPDC		121.95					10.73		1.65
	4W DS1 Digital Loop/4W DDITS Trunk Port - UNE Zone 2	2	UEPDC		148.62					10.73		1.65
	4W DS1 Digital Loop/4W DDITS Trunk Port - UNE Zone 3	3	UEPDC		234.11					10.73		1.65
UNE Loop Rates												
	4-Wire DS1 Digital Loop - UNE Zone 1	1	UEPDC	USLDC	69.22					10.73		1.65
	4-Wire DS1 Digital Loop - UNE Zone 2	2	UEPDC	USLDC				10.22		10.73		1.65
	4-Wire DS1 Digital Loop - UNE Zone 3	3	UEPDC	USLDC	181.38					10.73		1.65
UNE Port Rate												
	4-Wire DDITS Digital Trunk Port		UEPDC	UDDT1	62.73					10.73		1.65
NONRECURRING CHARGES - CURRENTLY COMBINED												
	4-Wire DS1 Digital Loop / 4-Wire DDITS Trunk Port Combination - Switches-is		UEPDC	USAC4		71.29	42.11			10.73		1.65
	4-Wire DS1 Digital Loop / 4-Wire DDITS Trunk Port Combination - Conversion with DS1 Changes		UEPDC	USAWA		71.29	42.11			10.73		1.65
	4-Wire DS1 Digital Loop / 4-Wire DDITS Trunk Port Combination - Conversion with Change - Trunk		UEPDC	USAW	8	71.29	42.11			10.73		1.65
ADDITIONAL NRCS												
	4-Wire DS1 Loop / 4-Wire DDITS Trunk Port - NRC - Subsequent Channel Activation/Chan - 2-Way Trunk		UEPDC	UDTTA		14.14	14.14			10.73		1.65
	4-Wire DS1 Loop / 4-Wire DDITS Trunk Port - Subsequent Channel Activation/Chan - 1-Way Outward Trunk		UEPDC	UDTTB		14.14	14.14			10.73		1.65
	4-Wire DS1 Loop / 4-Wire DDITS Trunk Port - Subseqt Channel Activation/Chan Inward Trunk w/out DID		UEPDC	UDTTC		14.14	14.14			10.73		1.65
	4-Wire DS1 Loop / 4-Wire DDITS Trunk Port - Subseqt Chan Activation Par Chan - Inward Trunk with DID		UEPDC	UDTTD		14.14	14.14			10.73		1.65
	4-Wire DS1 Loop / 4-Wire DDITS Trunk Port - Subseqt Chan Activation / Chan - 2-Way DID w User Trans		UEPDC	UDTTE		14.14	14.14			10.73		1.65
BIPOLAR & ZERO SUBSTITUTION												
	B&ZS - Superframe Format		UEPDC	CCOSF	0	665				10.73		1.65

Unbundled Network Elements
FLORIDA

	B8ZS - Extended Superframe Format		UEPDC	CCOEF	0	655				10.73		1.65
Alternate Mark Inversion												
	AMI - Superframe Format		UEPDC	MCOSF	0	0						
	AMI - Extended SuperFrame Format		UEPDC	MCOPO	0	0						
Telephone Number/Trunk Group Establishment Charges												
	Telephone Number for 2-Way Trunk Group		UEPDC	UDTAX	0						10.73	
	Telephone Number for 1-Way Outward Trunk Group		UEPDC	UDTAY	0						10.73	
	Telephone Number for 1-Way Inward Trunk Group Without DID		UEPDC	UDTIZ	0						10.73	
	DID Numbers, Establish Trunk Group and Provide First Group of 20 DID Numbers		UEPDC	ND2	0	0	0				10.73	
	DID Numbers for each Group of 20 DID Numbers		UEPDC	ND4	0						10.73	
	DID Numbers, Non-consecutive DID Numbers, Per Number		UEPDC	ND5	0						10.73	
	Reserve Non-Consecutive DID Nos.		UEPDC	ND6	0	0	0				10.73	
	Reserve DID Numbers		UEPDC	NDV	0	0	0				10.73	
Dedicated DS1 (Interoffice Channel Mileage) - FULCO for 4-Wire DS1 Digital Loop with 4-Wire COITS Trunk Port												
	Interoffice Channel Mileage - Fixed rate 0-8 miles (Facilities Termination)		UEPDC	ILUNO1	90.87	86.18	88.78	16.74	14.85		10.73	1.65
	Interoffice Channel Mileage - Additional rate per mile - 0-8 miles		UEPDC	ILUNOA	0.171	0	0					
	Interoffice Channel Mileage - Fixed rate 9-25 miles (Facilities Termination)		UEPDC	ILUNO2	0	0	0					
	Interoffice Channel Mileage - Additional rate per mile - 9-25 miles		UEPDC	ILUNOB	0.171	0	0					
	Interoffice Channel Mileage - Fixed rate 26+ miles (Facilities Termination)		UEPDC	ILUNO3	0	0	0	0				
	Interoffice Channel Mileage - Additional rate per mile - 26+ miles		UEPDC	ILUNOC	0.171	0	0					
	Local Number Portability, per DSO Activated		UEPDC	LNPCF	3.15	0	0	0				
	Central Office Terminating Point		UEPDC	CTG	0							
4-WIRE DS1 LOOP WITH CHANNELIZATION WITH PORT												
System is 1 DS1 Loop, 1 D4 Channel Bank, and up to 24 Feature Activations												
Each System can have up to 24 combinations of rates depending on type and number of ports used												
UNE DS1 Loop												
	4-Wire DS1 Loop - UNE Zone 1	1	UEPMG	USLDC	69.22	0	0					
	4-Wire DS1 Loop - UNE Zone 2	2	UEPMG	USLDC	95.69	0	0					
	4-Wire DS1 Loop - UNE Zone 3	3	UEPMG	USLDC	181.36	0	0					
UNE DSO Channelization Capabilities (D4 Channel Bank Configurations)												
	24 DSO Channel Capacity - 1 per DS1		UEPMG	VUM24	121.31	0	0					
	48 DSO Channel Capacity - 1 per 2 DS1s		UEPMG	VUM48	242.62	0	0					
	96 DSO Channel Capacity - 1 per 4 DS1s		UEPMG	VUM96	485.24	0	0					
	144 DSO Channel Capacity - 1 per 6 DS1s		UEPMG	VUM144	727.86	0	0					
	192 DSO Channel Capacity - 1 per 8 DS1s		UEPMG	VUM192	970.48	0	0					
	240 DSO Channel Capacity - 1 per 10 DS1s		UEPMG	VUM240	1213.10	0	0					
	288 DSO Channel Capacity - 1 per 12 DS1s		UEPMG	VUM288	1455.72	0	0					
	384 DSO Channel Capacity - 1 per 16 DS1s		UEPMG	VUM384	1940.96	0	0					
	480 DSO Channel Capacity - 1 per 20 DS1s		UEPMG	VUM480	2426.20	0	0					
	576 DSO Channel Capacity - 1 per 24 DS1s		UEPMG	VUM576	2911.44	0	0					
	672 DSO Channel Capacity - 1 per 28 DS1s		UEPMG	VUM672	3396.68	0	0					
Non-Receiving Charges (NRC) Associated with 4-Wire DS1 Loop with Channelization with Port - Conversion Charge Based on a System												
A Minimum System configuration is One (1) DS1, One (1) D4 Channel Bank, and Up To 24 DSO Ports with Feature Activations.												
Multiple of this configuration functioning as one are considered Add'l after the minimum system configuration is counted.												
	NRC - Conversion (Currently Combined) with or without BeSouth Allowed Changes		UEPMG	USAC4	0	72.61	3.82				10.73	1.65
System Additions at End User Locations Where 4-Wire DS1 Loop with Channelization with Port Combination Currently Exists and												
New (Not Currently Combined) in Georgia & Tennessee Only												
	NRC - 1 DS1/D4 Channel Bank - Add NRC for each Port and Assoc Feature Activation - New GA & TN Only		UEPMG	VUMD4	0	726.11	488.21	145.32	17.24		10.73	1.65
Bipolar & Zero Substitution												
	Clear Channel Capability Format, superframe - Subsequent Activity Only		UEPMG	CCOSF	0	0	655				10.73	1.65
	Clear Channel Capability Format - Extended Superframe - Subsequent Activity Only		UEPMG	CCOEF	0	0	655				10.73	1.65
Alternate Mark Inversion (AMI)												
	Superframe Format		UEPMG	MCOSF	0	0	0					
	Extended Superframe Format		UEPMG	MCOPO	0	0	0					
Exchange Ports Associated with 4-Wire DS1 Loop with Channelization with Port												
Exchange Ports												
	Line Side Combination Channelized PBX Trunk Port - Business		UEPPX	UEPCX	1.34	0	0	0	0		10.73	1.65
	Line Side Outward Channelized PBX Trunk Port - Business		UEPPX	UEPOX	1.34	0	0	0	0		10.73	1.65
	Line Side Inward Only Channelized PBX Trunk Port without DID		UEPPX	UEPIX	1.34	0	0	0	0		10.73	1.65
	2-Wire Trunk Side Unbundled Channelized DID Trunk Port		UEPPX	UEPDM	6.81	0	0	0	0		10.73	1.65

Feature Activations - Unbundled Loop Concentration										
Feature (Service) Activation for each Line Side Port Terminated in D4 Bank	UEPPX	IPOW	M	0.66	25.4	13.41	3.98	3.93	10.73	1.65
Feature (Service) Activation for each Trunk Side Port Terminated in D4 Bank	UEPPX	IPOW	U	0.66	78.16	18.42	56.03	10.95	10.73	1.65
Telephone Number Group Establishment Charges for DID Service										
DID Trunk Termination (1 per Port)	UEPPX	INDT	0						10.73	
Establish Trk Grp and Provide 1st 20 DID Nos. (FL, GA, NC, & SC)	UEPPX	INDZ	0	0	0	0			10.73	
DID Numbers - groups of 20 - Valid All States	UEPPX	IND4	0	0	0	0			10.73	
Non-Consecutive DID Numbers - per number	UEPPX	IND5	0	0	0	0			10.73	
Reserve Non-Consecutive DID Numbers	UEPPX	IND6	0	0	0	0			10.73	
Reserve DID Numbers	UEPPX	INDV	0	0	0	0			10.73	
Local Number Portability										
Local Number Portability - 1 per port	UEPPX	LNPCP	3.16	0	0					
FEATURES - Vertical and Optional										
Local Switching Features Offered with Line Side Ports Only										
All Features Available	UEPPX	UEPVF	2.17	0	0				10.73	1.65
UNBUNDLED PORT LOOP COMBINATIONS - MARKET RATES										
Market Rates shall apply where BellSouth is not required to provide unbundled local switching or switch ports per FCC and/or State Commission rules. These scenarios include: 1. Unbundled port/loop combinations that are Not Currently Combined in all of the BellSouth states except as noted for Georgia and Tennessee. 2. Unbundled port/loop combinations that are Currently Combined or Not Currently Combined in Zone 1 of the Top 8 MSAs in BellSouth's region for and users with 4 or more DSL equivalent lines. The Top 8 MSAs in BellSouth's region are: FL (Orlando, Ft. Lauderdale, Miami), GA (Atlanta), LA (New Orleans), NC (Greensboro-Winston Salem-Highpoint/Charlotte-Gastonia-Hook Hill), TN (Nashville). BellSouth currently is developing the billing capability to mechanically bill the recurring and non-recurring Market Rates in this section. In the interim, BellSouth shall bill the rates in the Cost-Based section preceding in lieu of the Market Rates and reserves the right to true-up the billing difference. The Market Rate for unbundled ports includes all available features in all states. End Office and Tandem Switching Usage and Common Transport Usage rates in the Port section of this rate exhibit shall apply to all combinations of loop/port network elements except for UNE Coln Port Loop Combinations which have a flat rate usage charge (USOC: UEFCU). For Not Currently Combined scenarios where Market Rates apply, the Nonrecurring charges are listed in the First and Additional NRC columns for each Port USOC. For Currently Combined scenarios, the Nonrecurring charges are listed in the NRC - Currently Combined section. Additional NRCs may apply also and are categorized accordingly.										
2-WIRE VOICE GRADE LOOP WITH 2-WIRE LINE PORT (RES)										
UNE Port/Loop Combination Rates										
2-Wire VG Loop/Port Combo - Zone 1	1			25.69						
2-Wire VG Loop/Port Combo - Zone 2	2			30.03						
2-Wire VG Loop/Port Combo - Zone 3	3			43.33						
UNE Loop Rates										
2-Wire Voice Grade Loop (SL1) - Zone 1	1	UEPRX	UEPLX	11.89						
2-Wire Voice Grade Loop (SL1) - Zone 2	2	UEPRX	UEPLX	16.03						
2-Wire Voice Grade Loop (SL1) - Zone 3	3	UEPRX	UEPLX	29.33						
2-Wire Voice Grade Line Port (Res)										
2-Wire voice unbundled port - residence		UEPRX	UEPRL	14	90	90			10.73	1.65
2-Wire voice unbundled port with Caller ID - res		UEPRX	UEPRC	14	90	90			10.73	1.65
2-Wire voice unbundled port outgoing only - res		UEPRX	UEPRO	14	90	90			10.73	1.65
2-Wire voice unbundled Florida Area Calling with Caller ID - res		UEPRX	UEPAF	14	90	90			10.73	1.65
2-Wire voice unbundled res. low usage line port with Caller ID (LUM)		UEPRX	UEPAP	14	90	90			10.73	1.65
LOCAL NUMBER PORTABILITY										
Local Number Portability (1 per port)		UEPRX	LNPCX	0.36						
FEATURES										
All Features Offered		UEPRX	UEPVF	0	0	0				
2-Wire Voice Grade Loop / Line Port Combination - Switch-as-is		UEPRX	USAC2		41.5	41.5				
2-Wire Voice Grade Loop / Line Port Combination - Switch with change		UEPRX	USACC		41.5	41.5				
ADDITIONAL NRCs										
NRC - 2-Wire Voice Grade Loop/Line Port Combination - Subsequent		UEPRX	USAS2		0	0				
2-WIRE VOICE GRADE LOOP WITH 2-WIRE LINE PORT (BUS)										
UNE Port/Loop Combination Rates										
2-Wire VG Loop/Port Combo - Zone 1	1			25.69						
2-Wire VG Loop/Port Combo - Zone 2	2			30.03						
2-Wire VG Loop/Port Combo - Zone 3	3			43.33						
UNE Loop Rates										
2-Wire Voice Grade Loop (SL1) - Zone 1	1	UEPBX	UEPLX	11.89						
2-Wire Voice Grade Loop (SL1) - Zone 2	2	UEPBX	UEPLX	16.03						
2-Wire Voice Grade Loop (SL1) - Zone 3	3	UEPBX	UEPLX	29.33						
2-Wire Voice Grade Line Port (Bus)										

Unbundled Network Elements
FLORIDA

	2-Wire voice unbundled port without Caller ID - bus			UEPBX	UEPBL	14	90	90			10.73		1.65
	2-Wire voice unbundled port with Caller + E484 ID - bus			UEPBX	UEPBC	14	90	90			10.73		1.65
	2-Wire voice unbundled port outgoing only - bus			UEPBX	UEPBO	14	90	90			10.73		1.65
LOCAL NUMBER PORTABILITY													
	Local Number Portability (1 per port)			UEPBX	LNPCX	0.35							
FEATURES													
NONRECURRING CHARGES - CURRENTLY COMBINED													
	2-Wire Voice Grade Loop / Line Port Combination - Switch-as-is			UEPBX	USAC2		41.5	41.5					
	2-Wire Voice Grade Loop / Line Port Combination - Switch with change			UEPBX	USACC		41.5	41.5					
ADDITIONAL NRCS													
	NRC - 2-Wire Voice Grade Loop/Line Port Combination - Subsequent			UEPBX	USAS2		0	0					
2-WIRE VOICE GRADE LOOP WITH 2-WIRE LINE PORT (RES - PBX)													
LINE Port/Loop Combination Rates													
	2-Wire VG Loop/Port Combo - Zone 1	1					25.89						
	2-Wire VG Loop/Port Combo - Zone 2	2					30.03						
	2-Wire VG Loop/Port Combo - Zone 3	3					43.33						
LINE Loop Rates													
	2-Wire Voice Grade Loop (SL1) - Zone 1	1		UEPRG	UEPLX		11.69						
	2-Wire Voice Grade Loop (SL1) - Zone 2	2		UEPRG	UEPLX		16.03						
	2-Wire Voice Grade Loop (SL1) - Zone 3	3		UEPRG	UEPLX		29.33						
2-Wire Voice Grade Line Port Rates (RES - PBX)													
	2-Wire VG Unbundled Combination 2-Way PBX Trunk Port - Res			UEPRG	UEPRD	14	90	90			10.73		1.65
LOCAL NUMBER PORTABILITY													
	Local Number Portability (1 per port)			UEPRG	LNPCP	3.16							
FEATURES													
NONRECURRING CHARGES - CURRENTLY COMBINED													
	2-Wire Voice Grade Loop/Line Port Combination - Switch-as-is			UEPRG	USAC2		41.5	41.5					
	2-Wire Voice Grade Loop/Line Port Combination - Switch with Change			UEPRG	USACC		41.5	41.5					
ADDITIONAL NRCS													
	2 Wire Loop/Line Side Port Combination - Non feature - Subsequent Activity - Nonrecuring						0	0					
	PBX Subsequent Activity - Change/Rearrange Multiline Hunt Group						7.09	7.09			10.73		1.65
2-WIRE VOICE GRADE LOOP WITH 2-WIRE LINE PORT (BUS - PBX)													
LINE Port/Loop Combination Rates													
	2-Wire VG Loop/Port Combo - Zone 1	1					25.89						
	2-Wire VG Loop/Port Combo - Zone 2	2					30.03						
	2-Wire VG Loop/Port Combo - Zone 3	3					43.33						
LINE Loop Rates													
	2-Wire Voice Grade Loop (SL1) - Zone 1	1		UEPPX	UEPLX		11.69						
	2-Wire Voice Grade Loop (SL1) - Zone 2	2		UEPPX	UEPLX		16.03						
	2-Wire Voice Grade Loop (SL1) - Zone 3	3		UEPPX	UEPLX		29.33						
2-Wire Voice Grade Line Port Rates (BUS - PBX)													
	Line Side Unbundled Combination 2-Way PBX Trunk Port - Bus			UEPPX	UEPPC	14	90	90			10.73		1.65
	Line Side Unbundled Outward PBX Trunk Port - Bus			UEPPX	UEPPD	14	90	90			10.73		1.65
	Line Side Unbundled Incoming PBX Trunk Port - Bus			UEPPX	UEPP1	14	90	90			10.73		1.65
	2-Wire Voice Unbundled PBX LD Terminal Ports			UEPPX	UEPLD	14	90	90			10.73		1.65
	2-Wire Voice Unbundled 2-Way Combination PBX Usage Port			UEPPX	UEPXA	14	90	90			10.73		1.65
	2-Wire Voice Unbundled PBX Toll Terminal Hotel Ports			UEPPX	UEPXB	14	90	90			10.73		1.65
	2-Wire Voice Unbundled PBX LD DDD Terminal Port			UEPPX	UEPXC	14	90	90			10.73		1.65
	2-Wire Voice Unbundled PBX LD Terminal Switchboard Port			UEPPX	UEPXD	14	90	90			10.73		1.65
	2-Wire Voice Unbundled PBX LD Terminal Switchboard IDD Capable Port			UEPPX	UEPXE	14	90	90			10.73		1.65
	2-Wire Voice Unbundled 2-Way PBX Hotel/Hospital Economy Administrative Calling Port			UEPPX	UEPXL	14	90	90			10.73		1.65
	2-Wire Voice Unbundled 2-Way PBX Hotel/Hospital Economy Room Calling Port			UEPPX	UEPXM	14	90	90			10.73		1.65
	2-Wire Voice Unbundled 1-Way Outgoing PBX Hotel/Hospital Discount Room Calling Port			UEPPX	UEPXO	14	90	90			10.73		1.65

	2-Wire Voice Unbundled 1-Way Outgoing PBX Measured Port	UEPPX	UEPRS	14	90	90				10.73		1.85
LOCAL NUMBER PORTABILITY												
	Local Number Portability (1 per port)	UEPPX	LNPCP	3.15								
FEATURES												
NONRECURRING CHARGES - CURRENTLY COMBINED												
	2-Wire Voice Grade Loop/ Line Port Combination - Switch-As-Is	UEPPX	USAC2		41.5	41.5						
	2-Wire Voice Grade Loop/ Line Port Combination - Switch with Change	UEPPX	USACC		41.5	41.5						
ADDITIONAL NPICs												
	2-Wire Voice Grade Loop/ Line Port Combination - Subsequent	UEPPX	USAS2		0	0						
	2-Wire Loop/Line Side Port Combination - Non Feature - Subsequent Activity - Nonrecurring				0	0						
	PBX Subsequent Activity - Change/Rearrange Multiline Hunt Group				7.09	7.09				10.73		1.85
2-WIRE VOICE GRADE LOOP WITH 2-WIRE ANALOG LINE COIN PORT												
UNE Port/Loop Combination Rates												
	2-Wire VG Coin Port/Loop Combo - Zone 1				25.89							
	2-Wire VG Coin Port/Loop Combo - Zone 2				30.03							
	2-Wire VG Coin Port/Loop Combo - Zone 3				43.33							
UNE Loop Rates												
	2-Wire Voice Grade Loop (SL1) - Zone 1	UEPCO	UEPLX		11.89							
	2-Wire Voice Grade Loop (SL1) - Zone 2	UEPCO	UEPLX		16.03							
	2-Wire Voice Grade Loop (SL1) - Zone 3	UEPCO	UEPLX		29.33							
2-Wire Voice Grade Line Port Rates (Coin)												
	2-Wire Coin 2-Way with Operator Screening and Blocking: 011, 900/976, 1+DDD (FL)	UEPCO	UEP2F	14	90	90				10.73		1.85
	2-Wire Coin 2-Way with Operator Screening and 011 Blocking (FL)	UEPCO	UEPFA	14	90	90				10.73		1.85
	2-Wire Coin 2-Way with Operator Screening and Blocking: 900/976, 1+DDD, 011+, and Local (FL)	UEPCO	UEPC9	14	90	90				10.73		1.85
	2-Wire Coin Outward with Operator Screening and 011 Blocking (AL, FL)	UEPCO	UEPRK	14	90	90				10.73		1.85
	2-Wire Coin Outward with Operator Screening and Blocking: 900/976, 1+DDD, 011+, (FL)	UEPCO	UEPOF	14	90	90				10.73		1.85
	2-Wire Coin Outward with Operator Screening and Blocking: 900/976, 1+DDD, 011+, and Local (FL, GA)	UEPCO	UEPCO	14	90	90				10.73		1.85
LOCAL NUMBER PORTABILITY												
	Local Number Portability (1 per port)	UEPCO	LNPCX	0.35								
NONRECURRING CHARGES - CURRENTLY COMBINED												
	2-Wire Voice Grade Loop/ Line Port Combination - Switch-As-Is	UEPCO	USAC2		41.5	41.5						
	2-Wire Voice Grade Loop/ Line Port Combination - Switch with Change	UEPCO	USACC		41.5	41.5						
ADDITIONAL NPICs												
	2-Wire Voice Grade Loop/ Line Port Combination - Subsequent	UEPCO	USAS2		0	0						

ATTACHMENT 3
NETWORK INTERCONNECTION

TABLE OF CONTENTS

1. GENERAL.....	3
2. DEFINITIONS: (FOR THE PURPOSE OF THIS ATTACHMENT)	3
3. NETWORK INTERCONNECTION.....	4
4. INTERCONNECTION TRUNK GROUP ARCHITECTURES	6
5. NETWORK DESIGN AND MANAGEMENT FOR INTERCONNECTION.....	12
6. LOCAL DIALING PARITY	15
7. INTERCONNECTION COMPENSATION.....	16
8. FRAME RELAY SERVICE INTERCONNECTION.....	21
9. OPERATIONAL SUPPORT SYSTEMS (OSS).....	24
Rates	Exhibit A
Basic Architecture	Exhibit B
One Way Architecture	Exhibit C
Two Way Architecture	Exhibit D
Supergroup Architecture	Exhibit E

NETWORK INTERCONNECTION

1. GENERAL

1.1 The Parties shall provide interconnection with each other's networks for the transmission and routing of telephone exchange service (local) and exchange access (intraLATA toll and switched access) on the following terms:

2. DEFINITIONS: (FOR THE PURPOSE OF THIS ATTACHMENT)

2.1 For purposes of this attachment only, the following terms shall have the definitions set forth below:

2.1.1 **Call Termination** has the meaning set forth for "termination" in 47CFR § 51.701(d).

2.1.2 **Call Transport** has the meaning set forth for "transport" in 47 CFR § 51.701(c).

2.1.3 **Call Transport and Termination** is used collectively to mean the switching and transport functions from the Interconnection Point to the last point of switching.

2.1.4 **Common (Shared) Transport** is defined as the transport of the originating Party's traffic by the terminating Party over the terminating Party's common (shared) facilities between (1) the terminating Party's tandem switch and end office switch, (2) between the terminating Party's tandem switches, and/or (3) between the terminating Party's host and remote end office switches. All switches referred herein must be entered into the Local Exchange Routing Guide ("LERG").

2.1.5 **Dedicated Interoffice Facility** is defined as a switch transport facility between a Party's Serving Wire Center and the first point of switching on the other Party's common (shared) network.

2.1.6 **End Office Switching** is defined as the function that establishes a communications path between the trunk side and line side of the End Office switch.

2.1.7 **Fiber Meet** is an interconnection arrangement whereby the Parties physically interconnect their networks via an optical fiber interface at which one Party's facilities, provisioning, and maintenance responsibility begins and the other Party's responsibility ends.

2.1.8 **Interconnection Point ("IP")** is the physical telecommunications equipment interface that performs the interconnection function for BellSouth and Heritage.

2.1.9 **ISP-bound Traffic** is as defined in Section 7 of this Attachment.

- 2.1.10 **Local Channel** is defined as a switched transport facility between a Party's Interconnection Point and it's the IP's Serving Wire Center.
- 2.1.11 **Local Traffic** is as defined in Section 7 of this Attachment.
- 2.1.12 **Serving Wire Center** is defined as the wire center owned by one Party from which the other Party would normally obtain dial tone for its IP.
- 2.1.13 **Tandem Switching** is defined as the function that establishes a communications path between two switching offices through a third switching office through the provision of trunk side to trunk side switching.
- 2.1.14 **Transit Traffic** is traffic originating on Heritage's network that is switched and/or transported by BellSouth and delivered to a third party's network, or traffic originating on a third Party's network that is switched and/or transported by BellSouth and delivered to Heritage's network.
- 3. **NETWORK INTERCONNECTION**
 - 3.1 This Attachment pertains only to the provision of network interconnection where Heritage owns and provides its switch(es).
 - 3.2 Network interconnection may be provided by the Parties at any technically feasible point within BellSouth's network. Requests to BellSouth for interconnection at points other than as set forth in this Attachment may be made through the Bona Fide Request/New Business Request process set out in this Agreement.
 - 3.2.1 Each Party is responsible for providing, engineering and maintaining the network on its side of the IP. The IP must be located within BellSouth's serving territory in the LATA in which local traffic is originating. The IP determines the point at which the originating Party shall pay the terminating Party for the Call Transport and Termination of that traffic.
 - 3.2.1.1 When first establishing the interconnection arrangement in each LATA, the location of the IP shall be established by mutual agreement of the Parties. In selecting the IP, both Parties will act in good faith and select the point which is most efficient for both Parties. If the Parties are unable to agree on the location of the IP, each Party will designate IPs for its originated traffic. Additional IP(s) in a particular LATA may be established by mutual agreement of the Parties. If the Parties are unable to agree to additional IPs, each Party will designate the IP for its originated traffic. When the Parties agree to utilize two-way interconnection trunk groups for the exchange of Local Traffic, the Parties must agree to the location of the IP(s).
 - 3.3 **Interconnection via Dedicated Facilities**

- 3.3.1 **Local Channel Facilities.** As part of network interconnection, the originating Party may obtain Local Channel facilities from the terminating Party. The portion of Local Channel facilities utilized for Local Traffic shall be determined based upon the application of the Percent Local Facility (PLF) Factor. The charges applied to the portion of the Local Channel used for Local Traffic as determined by the PLF are as set forth in Exhibit A to this Attachment.
- 3.3.2 **Dedicated Interoffice Facilities.** As a part of network interconnection, the originating Party may obtain Dedicated Interoffice Facilities. The portion of Dedicated Interoffice Facilities utilized for Local Traffic shall be determined based upon the application of the Percent Local Facility (PLF) Factor. The charges applied to the portion of the Dedicated Interoffice Facility used for Local Traffic as determined by the PLF are as set forth in Exhibit A to this Attachment.
- 3.4 **Fiber Meet**
- 3.4.1 If Heritage elects to interconnect with BellSouth pursuant to a Fiber Meet, Heritage and BellSouth shall jointly engineer, operate and maintain a Synchronous Optical Network ("SONET") transmission system by which they shall interconnect their transmission and routing of Local Traffic via a Local Channel at either the DS1 or DS3 level. The Parties shall work jointly to determine the specific transmission system. However, Heritage's SONET transmission system must be compatible with BellSouth's equipment, and the Data Communications Channel (DCC) must be turned off.
- 3.4.2 Each Party, at its own expense, shall procure, install and maintain the agreed upon SONET transmission system in its network .
- 3.4.3 The Parties shall agree to a Fiber Meet point between the BellSouth Serving Wire Center and the Heritage Serving Wire Center. The Parties shall deliver their fiber optic facilities to the Fiber Meet point with sufficient spare length to reach the fusion splice point for the Fiber Meet Point. BellSouth shall, at its own expense, provide and maintain the fusion splice point for the Fiber Meet. A building type Common Language Location Identification ("CLLI") code will be established for each Fiber Meet point. All orders for interconnection facilities from the Fiber Meet point shall indicate the Fiber Meet point as the originating point for the facility .
- 3.4.4 Upon verbal request by Heritage, BellSouth shall allow Heritage access to the fusion splice point for the Fiber Meet point for maintenance purposes on Heritage's side of the Fiber Meet point.
- 3.4.5 Neither Party shall charge the other for it's the Local Channel portion of the Fiber Meet facility used exclusively for Local Traffic . All the appropriate charges will apply. Charges for switched and special access services shall be billed in accordance with the applicable access service tariff.

4. INTERCONNECTION TRUNK GROUP ARCHITECTURES

- 4.1 BellSouth and Heritage shall establish interconnecting trunk groups and trunk group configurations between networks, including the use of one-way or two-way trunks in accordance with the following provisions set forth in this Agreement. For trunking purposes, traffic will be routed based on the digits dialed by the originating end user and in accordance with the LERG.
- 4.2 Heritage shall establish an interconnection trunk group(s) to at least one BellSouth access tandem within the LATA for the delivery of Heritage's originated Local Traffic and for the receipt and delivery of Transit Traffic. To the extent Heritage desires to deliver Local Traffic and/or Transit Traffic BellSouth access tandems within the LATA, other than the tandems(s) to which Heritage has established interconnection trunk groups, Heritage shall order Multiple Tandem Access, as described in this Attachment, to such other BellSouth access tandems.
- 4.2.1 Notwithstanding the forgoing, Heritage shall establish an interconnection trunk group(s) to all BellSouth access and local tandems in the LATA where Heritage has homed (i.e. assigned) its NPA/NXXs. Heritage shall home its NPA/NXXs on the BellSouth tandems that serve the exchange rate center areas to which the NPA/NXXs are assigned. The specified exchange rate center assigned to each BellSouth tandem is defined in the LERG. Heritage shall enter its NPA/NXX access and/or local tandem homing arrangements into the LERG.
- 4.3 Switched access traffic will be delivered to and from Interexchange Carriers (IXCs) based on Heritage's NXX access tandem homing arrangement as specified by Heritage in the LERG.
- 4.4 Any Heritage interconnection request that (1) deviates from the interconnection trunk group architectures as described in this Agreement, (2) affects traffic delivered to Heritage from a BellSouth switch, and (3) requires special BellSouth switch translations and other network modifications will require Heritage to submit a Bona Fide Request/New Business Request (BFR/NBR) via the BFR/NBR Process as set forth in this Agreement.
- 4.5 Recurring and non-recurring rates associated with interconnecting trunk groups between BellSouth and Heritage are set forth in Exhibit A. To the extent a rate associated with the interconnecting trunk group is not set forth in Exhibit A, the rate shall be as set forth in the appropriate BellSouth tariff for switched access services.
- 4.6 For two-way trunk groups that carry only both Parties' Local Traffic, the Parties shall be compensated at 50% of the nonrecurring and recurring rates for dedicated trunks and facilities. Heritage shall be responsible for ordering and paying for any two-way trunks carrying Transit Traffic.

- 4.7 All trunk groups will be provisioned as Signaling System 7 (SS7) capable where technically feasible. If SS7 is not technically feasible multi-frequency (MF) protocol signaling shall be used.
- 4.8 In cases where Heritage is also an IXC, the IXC's Feature Group D (FG D) trunk group(s) must remain separate from the local interconnection trunk group(s).
- 4.9 Each Party shall order interconnection trunks and trunk group, including trunk and trunk group augmentations via the ASR process. A Firm Order Confirmation (FOC) shall be returned to the ordering Party, after receipt of a valid, error free ASR, within the timeframes set forth in Attachment 9 to this Agreement. Notwithstanding the foregoing, blocking situations and projects shall be managed through BellSouth's Local Interconnection Switching Center (LISC) Project Management Group and Heritage's equivalent trunking group, and FOCs for such orders shall be returned in the timeframes applicable to the project. A project is defined as (1) a new trunk group or (2) a request for more than 96 trunks on a single or multiple group(s) in a given BellSouth local calling area.
- 4.10 **Interconnection Trunk Groups for Exchange of Local Traffic and Transit Traffic**
- 4.10.1 Upon mutual agreement of the Parties in a joint planning meeting, the Parties' shall exchange Local Traffic on two-way interconnection trunk group(s) with the quantity of trunks being mutually determined and the provisioning being jointly coordinated. Furthermore, the Parties shall agree upon the IP(s) for two-way interconnection trunk groups transporting both Parties Local Traffic. Heritage shall order such two-way trunks via the Access Service Request (ASR) process. BellSouth will use the Trunk Group Service Request (TGSR) to request changes in trunking. Furthermore, the Parties shall jointly review trunk performance and forecasts on a periodic basis. The Parties use of two-way interconnection trunk groups for the transport of Local Traffic between the Parties does not preclude either Party from establishing additional one-way interconnection trunks for the delivery of its originated Local Traffic to the other Party.
- 4.10.2 **BellSouth Access Tandem Interconnection**
- 4.10.2.1 BellSouth access tandem interconnection at a single access tandem provides access to those end offices subtending that access tandem ("Intratandem Access"). Access tandem interconnection is available for any of the following access tandem architectures
- 4.10.2.2 **Basic Architecture**
- 4.10.2.2.1 In the basic architecture, Heritage's originating Local Traffic and originating and terminating Transit Traffic is transported on a single two-way trunk group between Heritage and BellSouth access tandem(s) within a LATA to provide Intratandem

Access. This trunk group carries Transit Traffic between Heritage and Independent Companies, Interexchange Carriers, other CLECs, CMRS providers that have a Meet Point Billing arrangement with BellSouth, and other network providers with which Heritage desires to exchange traffic. This trunk group also carries Heritage originated Transit Traffic transiting a single BellSouth access tandem destined to third party tandems such as an Independent Company tandem or other CLEC tandem. BellSouth originated Local Traffic is transported on a separate single one-way trunk group terminating to Heritage. Other trunk groups for operator services, directory assistance, emergency services and intercept must be established if service is requested. The LERG contains current routing and tandem serving arrangements. The basic Architecture is illustrated in Exhibit B.

4.10.2.3 One-Way Trunk Group Architecture

4.10.2.3.1 In one-way trunk group architecture, the Parties interconnect using three separate trunk groups. A one-way trunk group provides Intratandem Access for Heritage-originated Local Traffic destined for BellSouth end-users. A second one-way trunk group carries BellSouth-originated Local Traffic destined for Heritage end-users. A two-way trunk group provides Intratandem Access for Heritage's originating and terminating Transit Traffic. This trunk group carries Transit Traffic between Heritage and Independent Companies, Interexchange Carriers, other CLECs, CMRS providers that have a Meet Point Billing arrangement with BellSouth, and other network providers with which Heritage desires to exchange traffic. This trunk group also carries Heritage originated Transit Traffic transiting a single BellSouth access tandem destined to third party tandems such as an Independent Company tandem or other CLEC tandem. BellSouth originated Local Traffic is transported on a separate single one-way trunk group terminating to Heritage. Other trunk groups for operator services, directory assistance, emergency services and intercept must be established if service is requested. The LERG contains current routing and tandem serving arrangements. The one-way trunk group architecture is illustrated in Exhibit C.

4.10.2.4 Two-Way Trunk Group Architecture

4.10.2.4.1 Upon agreement of the Parties as set forth in Section 4.10.1 above, the two-way trunk group Architecture establishes one two-way trunk group to provide Intratandem Access for the exchange of Local Traffic between Heritage and BellSouth. In addition, a separate two-way transit trunk group must be established for Heritage's originating and terminating Transit Traffic. This trunk group carries Transit Traffic between Heritage and Independent Companies, Interexchange Carriers, other CLECs, CMRS providers that have a Meet Point Billing arrangement with BellSouth, and other network providers with which Heritage desires to exchange traffic. This trunk group also carries Heritage originated Transit Traffic transiting a single BellSouth access tandem destined to third party tandems such as an Independent Company tandem or other CLEC tandem.

BellSouth originated Local Traffic is transported on a separate single one-way trunk group terminating to Heritage. Other trunk groups for operator services, directory assistance, emergency services and intercept must be established if service is requested. The LERG contains current routing and tandem serving arrangements. The two-way trunk group architecture is illustrated in Exhibit D.

4.10.2.5 Supergroup Architecture

4.10.2.5.1 Upon agreement of the Parties as set forth in Section 4.10.1 above, the Parties may establish a supergroup architecture. In the supergroup architecture, the Parties' Local Traffic and Heritage's Transit Traffic are exchanged on a single two-way trunk group between Heritage and BellSouth to provide Intratandem Access to Heritage. This trunk group carries Transit Traffic between Heritage and Independent Companies, Interexchange Carriers, other CLECs, CMRS providers that have a Meet Point Billing arrangement with BellSouth, and other network providers with which Heritage desires to exchange traffic. This trunk group also carries Heritage originated Transit Traffic transiting a single BellSouth access tandem destined to third party tandems such as an Independent Company tandem or other CLEC tandem. BellSouth originated Local Traffic is transported on a separate single one-way trunk group terminating to Heritage. Other trunk groups for operator services, directory assistance, emergency services and intercept must be established if service is requested. The LERG contains current routing and tandem serving arrangements. The supergroup architecture is illustrated in Exhibit D..

4.10.3 Multiple Tandem Access Interconnection

4.10.3.1 Where Heritage does not choose access tandem interconnection at every BellSouth access tandem within a LATA, Heritage may utilize BellSouth multiple tandem access interconnection (MTA). To utilize MTA Heritage must establish an interconnection trunk group(s) at a BellSouth access tandem through multiple BellSouth access tandems within the LATA as required. BellSouth will route Heritage's originated Local Traffic for LATA wide transport and termination. Heritage must also establish an interconnection trunk group(s) at all BellSouth access tandems where Heritage NXXs are homed as described in Section 4.2.1 above. If Heritage does not have NXXs homed at any particular BellSouth access tandem within a LATA and elects not to establish an interconnection trunk group(s) at such BellSouth access tandem, Heritage can order MTA in each BellSouth access tandem within the LATA where it does have an interconnection trunk group(s) and BellSouth will terminate Heritage's Local Traffic to end-users served through those BellSouth access tandems where Heritage does not have an interconnection trunk group(s). MTA shall be provisioned in accordance with BellSouth's Ordering Guidelines.

4.10.3.2 Heritage may also utilize MTA to route its originated Transit Traffic; provided, however, that MTA may not be utilized to route switched access traffic that

transits the BellSouth network to an Interexchange Carrier (IXC). Switched access traffic originated by or terminated to Heritage will be delivered to and from IXCs based on Heritage's NXX access tandem homing arrangement as specified by Heritage in the LERG.

- 4.10.3.3 Compensation for MTA shall be at the applicable tandem switching and transport charges specified in Exhibit A to this Attachment and shall be billed in addition to any Call Transport and Termination charges.
- 4.10.3.4 To the extent Heritage does not purchase MTA in a LATA served by multiple access tandems, Heritage must establish an interconnection trunk group(s) to every access tandem in the LATA to serve the entire LATA. To the extent Heritage routes its traffic in such a way that utilizes BellSouth's MTA service without properly ordering MTA service, Heritage agrees to pay BellSouth the associated transport and termination charges.
- 4.10.4 **Local Tandem Interconnection**
- 4.10.4.1 Local Tandem Interconnection arrangement allows Heritage to establish an interconnection trunk group(s) at BellSouth local tandems for: (1) the delivery of Heritage-originated Local Traffic transported and terminated by BellSouth to BellSouth end offices within the local calling area as defined in BellSouth's General Subscriber Services Tariff (GSST), Section A3 served by those BellSouth local tandems, and (2) for local Transit Traffic transported by BellSouth for third party network providers who have also established an interconnection trunk group(s) at those BellSouth local tandems.
- 4.10.4.2 When a specified local calling area is served by more than one BellSouth local tandem, Heritage must designate a "home" local tandem for each of its assigned NPA/NXXs and establish trunk connections to such local tandems. Additionally, Heritage may choose to establish an interconnection trunk group(s) at the BellSouth local tandems where it has no codes homing but is not required to do so. Heritage may deliver Local Traffic to a "home" BellSouth local tandem that is destined for other BellSouth or third party network provider end offices subtending other BellSouth local tandems in the same local calling area where Heritage does not choose to establish an interconnection trunk group(s). It is Heritage's responsibility to enter its own NPA/NXX local tandem homing arrangements into the LERG either directly or via a vendor in order for other third party network providers to determine appropriate traffic routing to Heritage's codes. Likewise, Heritage shall obtain its routing information from the LERG.
- 4.10.4.3 Notwithstanding establishing an interconnection trunk group(s) to BellSouth's local tandems, Heritage must also establish an interconnection trunk group(s) to BellSouth access tandems within the LATA on which Heritage has NPA/NXXs homed for the delivery of Interexchange Carrier Switched Access (SWA) and toll traffic, and traffic to Type 2A CMRS connections located at the access tandems.

BellSouth shall not switch SWA traffic through more than one BellSouth access tandem. SWA, Type 2A CMRS or toll traffic routed to the local tandem in error will not be backhauled to the BellSouth access tandem for completion. (Type 2A CMRS interconnection is defined in BellSouth's A35 General Subscriber Services Tariff).

- 4.10.4.4 BellSouth's provisioning of local tandem interconnection assumes that Heritage has executed the necessary Local Interconnection Agreements with the other third party network providers subtending those local tandems as required by the Act.
- 4.10.5 **Direct End Office-to-End Office Interconnection**
- 4.10.5.1 Direct End Office-to-End Office one-way or two-way interconnection trunk groups allow for the delivery of a Party's originating local or intraLATA toll traffic to the terminating Party on a direct end office-to-end office basis.
- 4.10.5.2 The Parties shall utilize direct end office-to-end office trunk groups under the following conditions:
- 4.10.5.2.1 (1) Tandem Exhaust - If a tandem through which the Parties are interconnected is unable to, or is forecasted to be unable to support additional traffic loads for any period of time, the Parties will mutually agree on an end office trunking plan that will alleviate the tandem capacity shortage and ensure completion of traffic between Heritage and BellSouth's subscribers.
- 4.10.5.2.2 (2) Traffic Volume -To the extent either Party has the capability to measure the amount of traffic between a Heritage switching center and a BellSouth end office, either Party shall install and retain direct end office trunking sufficient to handle actual or reasonably forecasted traffic volumes, whichever is greater, between a Heritage switching center and a BellSouth end office where the traffic exceeds or is forecasted to exceed a single DS1 of traffic per month. Either Party will install additional capacity between such points when overflow traffic between Heritage's switching center and BellSouth's end office exceeds or is forecasted to exceed a single DS1 of traffic per month. In the case of one way trunking, additional trunking shall only be required by the Party whose trunking has achieved the preceding usage threshold.
- 4.10.5.2.3 (3) Mutual Agreement - The Parties may install direct end office trunking upon mutual agreement in the absence of conditions (1) or (2) above, and agreement will not unreasonably be withheld.
- 4.10.6 **Transit Traffic Trunk Group**
- 4.10.6.1 Transit Traffic trunks can either be two-way trunks or two one-way trunks ordered by Heritage to deliver and receive local and intraLATA toll Transit Traffic from third parties, such as Independent Companies and other CLECs, via BellSouth

access tandems (or BellSouth local tandems for Local Traffic), and Switched Access traffic to and from Interexchange Carriers via BellSouth access tandems pursuant to the Transit Traffic section of this Attachment. Establishing Transit Traffic trunks at BellSouth access and local tandems provides intratandem access to the third parties also interconnected at those tandems.

4.10.6.2 Toll Free Traffic

4.10.6.2.1 If Heritage chooses BellSouth to handle Toll Free database queries from its switches, all Heritage originating Toll Free traffic will be routed over the Transit Traffic Trunk Group.

4.10.6.2.2 All originating Toll Free Service (Toll Free) calls for which Heritage requests that BellSouth perform the Service Switching Point ("SSP") function (i.e., perform the database query) shall be delivered using GR-394 format over the Transit Traffic Trunk Group. Carrier Code "0110" and Circuit Code (to be determined for each LATA) shall be used for all such calls.

4.10.6.2.3 Heritage may handle its own Toll Free database queries from its switch. If so, Heritage will determine the nature (local/intraLATA/interLATA) of the Toll Free call based on the response from the database. If the query determines that the call is a BellSouth local or intraLATA Toll Free number, Heritage will route the post-query local or IntraLATA converted ten-digit local number to BellSouth over the local or intraLATA trunk group. If the query determines that the call is a third party (ICO or other CLEC) local or intraLATA Toll Free number, Heritage will route the post-query local or intraLATA converted ten-digit local number to BellSouth over the Transit Traffic Trunk Group. In such case, Heritage is to provide a Toll Free billing record when appropriate. If the query reveals the call is an interLATA Toll Free number, Heritage will route the post-query interLATA call (Toll Free number) directly from its switch for carriers interconnected with its network or over the Transit Traffic Trunk Group to carriers not directly connected to its network but are connected to BellSouth's access tandem. Calls will be routed to BellSouth over the local/intraLATA and Transit Traffic Trunk Groups within the LATA in which the calls originate.

4.10.6.2.4 All post-query Toll Free Service (Toll Free) calls for which Heritage performs the SSP function, if delivered to BellSouth, shall be delivered using GR-394 format for calls destined to IXCs, and GR-317 format for calls destined to end offices that directly subtend the BellSouth access tandem.

5. NETWORK DESIGN AND MANAGEMENT FOR INTERCONNECTION

5.1 Network Management and Changes. Both Parties will work cooperatively with each other to install and maintain the most effective and reliable interconnected telecommunications networks, including but not limited to, the exchange of toll-free maintenance contact numbers and escalation procedures. Both Parties agree

to provide public notice of changes in the information necessary for the transmission and routing of services using its local exchange facilities or networks, as well as of any other changes that would affect the interoperability of those facilities and networks.

- 5.2 **Interconnection Technical Standards.** The interconnection of all networks will be based upon accepted industry/national guidelines for transmission standards and traffic blocking criteria. Interconnecting facilities shall conform, at a minimum, to the telecommunications industry standard of DS-1 pursuant to Bellcore Standard No. TR-NWT-00499. Signal transfer point, Signaling System 7 (“SS7”) connectivity is required at each interconnection point. BellSouth will provide out-of-band signaling using Common Channel Signaling Access Capability where technically and economically feasible, in accordance with the technical specifications set forth in the BellSouth Guidelines to Technical Publication, TR-TSV-000905. Facilities of each Party shall provide the necessary on-hook, off-hook answer and disconnect supervision and shall hand off calling number ID (Calling Party Number) when technically feasible.
- 5.3 **Quality of Interconnection.** The local interconnection for the transmission and routing of telephone exchange service and exchange access that each Party provides to each other will be at least equal in quality to what it provides to itself and any subsidiary or affiliate, where technically feasible, or to any other Party to which each Party provides local interconnection.
- 5.4 **Network Management Controls.** Both Parties will work cooperatively with each other to apply sound network management principles by invoking appropriate network management controls (e.g., call gapping) to alleviate or prevent network congestion.
- 5.5 **Common Channel Signaling.** Both Parties will provide LEC-to-LEC Common Channel Signaling (“CCS”) to each other, where available, in conjunction with all traffic in order to enable full interoperability of CLASS features and functions except for call return. All CCS signaling parameters will be provided, including automatic number identification (“ANI”), originating line information (“OLI”) calling company category, charge number, etc. All privacy indicators will be honored, and each Party will cooperate with each other on the exchange of Transactional Capabilities Application Part (“TCAP”) messages to facilitate full interoperability of CCS-based features between the respective networks. Neither Party shall alter the CCS parameters, or be a party to altering such parameters, or knowingly pass CCS parameters that have been altered in order to circumvent appropriate interconnection charges.
- 5.6 **Signaling Call Information.** BellSouth and Heritage will send and receive 10 digits for Local Traffic. Additionally, BellSouth and Heritage will exchange the proper call information, i.e. originated call company number and destination call company

number, CIC, and OZZ, including all proper translations for routing between networks and any information necessary for billing.

5.7 Forecasting for Trunk Provisioning

- 5.7.1** Within six (6) months after execution of this agreement, Heritage shall provide an initial interconnection trunk group forecast for each LATA that it shall provide service within BellSouth's region. Upon receipt of Heritage's forecast, the Parties shall schedule and participate in a joint planning meeting to develop a joint interconnection trunk group forecast. Each forecast provided under this Section shall be deemed "Confidential Information" under the General Terms and Conditions of this Agreement.
- 5.7.1.1** At a minimum, the forecast shall include the projected quantity of Transit Trunks, Heritage-to-BellSouth one-way trunks ("Heritage Trunks"), BellSouth-to-Heritage one-way trunks ("Reciprocal Trunks") and/or two-way interconnection trunks, if the Parties have agreed to interconnect using two-way trunking to transport the Parties' local and intraLATA toll. The quantities shall be projected for a minimum of six months in advance and shall include the current year plus next two years total forecasted quantities. Considering Heritage's provided forecast, the Parties shall mutually develop Reciprocal Trunk and/or two-way interconnection trunk forecast quantities for the time periods listed and to be included within the initial forecast.
- 5.7.1.2** Additionally all forecasts shall include, at a minimum, Access Carrier Terminal Location ("ACTL"), trunk group type (local/intraLATA toll, Transit, Operator Services, 911, etc.), A location/Z location (CLLI codes for Heritage location and BellSouth location where the trunks shall terminate), interface type (e.g., DS1), Direction of Signaling, Trunk Group Number, if known, (commonly referred to as the 2-6 code) and forecasted trunks in service each year (cumulative).
- 5.7.2** Each Party shall exercise its best efforts to provide the quantity of interconnection trunks mutually forecasted. However, the provision of the forecasted quantity of interconnection trunks is subject to trunk terminations and facility capacity existing at the time the trunk order is submitted. Furthermore, the receipt and development of trunk forecasts does not imply any liability for failure to perform if capacity (trunk terminations or facilities) is not available for use at the forecasted time.
- 5.7.3** The submitting and development of interconnection trunk forecasts shall not replace the ordering process in place for local interconnection trunks.
- 5.7.4** Once initial interconnection trunk forecasts have been developed, Heritage shall continue to provide interconnection trunk forecasts on a semiannual basis or at otherwise mutually agreeable intervals. Heritage shall use its best efforts to make the forecasts as accurate as possible based on reasonable engineering criteria. Interconnection trunk forecasts shall be updated and provided to BellSouth on an

as needed basis, but no less frequently than semiannually and no more frequently than monthly. Upon receipt of Heritage's forecast, including forecast updates, the Parties shall confer to mutually develop BellSouth Reciprocal Trunk and/or two-way interconnection trunk forecasted quantities for the listed time periods within such subsequent forecasts.

5.8 Trunk Utilization

5.8.1 BellSouth and Heritage shall monitor traffic on each interconnection trunk group that is installed pursuant to the initial interconnection trunk requirements and subsequent forecasts. At any time after the end of a calendar quarter, based on a review of the capacity utilization during such quarter for installed reciprocal trunk groups and/or two-way interconnection trunk groups, subject to the provisions of the section following, BellSouth may disconnect any non-utilized or under-utilized reciprocal trunk(s) and Heritage shall refund to BellSouth any associated trunk and facility charges paid by BellSouth. BellSouth may request Heritage to disconnect any under-utilized two-way interconnection trunk(s), if BellSouth has determined that the trunk group is not being utilized at eighty-five percent (85%) of the time consistent busy hour utilization level, provided that the Parties have not otherwise agreed. Heritage shall comply with all such requests, subject to Section 5.8.1.1 below. Under-utilized trunks are defined as the trunks being utilized at less than 85% as a result of a time consistent busy hour utilization.

5.8.1.1 BellSouth's LISC will notify the Heritage of any under-utilized reciprocal trunk groups and the number of trunks that BellSouth wishes to disconnect. BellSouth will provide supporting information either by email or facsimile to the designated Heritage interface. Heritage will provide concurrence with the disconnection in seven (7) business days or will provide specific information supporting why the trunks should not be disconnected. Such supporting information should include expected Local Number Ported (LNP) and traffic volumes and the timeframes within which Heritage expects to need such trunks. BellSouth's LISC Project Manager and Circuit Capacity Manager will discuss the information with Heritage to determine if agreement can be reached on the number of trunks to be removed. If no agreement can be reached, BellSouth will issue disconnect orders to Heritage. The due date of these orders will be four weeks after Heritage was first notified in writing of the underutilization of the trunk groups.

5.8.1.2 Heritage monitors all direct trunks from Heritage to BellSouth. If Heritage wishes to disconnect any such trunks, Heritage shall issue an ASR to do so.

5.8.2 To the extent that any interconnection trunk group is utilized at a time-consistent busy hour of eighty-five percent (85%) or greater, the Parties shall negotiate in good faith for the installation of augmented facilities.

6. LOCAL DIALING PARITY

- 6.1 BellSouth and Heritage shall provide local and toll dialing parity to each other with no unreasonable dialing delays. Dialing parity shall be provided for all originating telecommunications services that require dialing to route a call. BellSouth and Heritage shall permit similarly situated telephone exchange service end users to dial the same number of digits to make a local telephone call notwithstanding the identity of the end user's or the called party's telecommunications service provider.
7. **INTERCONNECTION COMPENSATION**
- 7.1 **Compensation for Call Transportation and Termination for Local Traffic and ISP-bound Traffic**
- 7.1.1 For reciprocal compensation between the Parties pursuant to this Attachment, Local Traffic is defined as any circuit switched call that is originated by an end user of one Party and terminated to an end user of the other Party within a given LATA on that other Party's network, except for those calls that are originated or terminated through switched access arrangements as established by the ruling regulatory body.
- 7.1.1.1 Additionally, Local Traffic includes any cross boundary, voice-to-voice intrastate, interLATA or interstate, interLATA calls established as a local call by the ruling regulatory body.
- 7.1.2 ISP-bound Traffic is defined as calls to an information service provider or Internet service provider ("ISP") that are dialed by using a local dialing pattern (7 or 10 digits) by a calling party in one exchange or local calling area to an ISP server or modem in the same exchange or local calling area. ISP-bound Traffic is not considered Local Traffic subject to reciprocal compensation, but instead is information traffic subject to interstate compensation.
- 7.1.3 Neither Party shall pay compensation to the other Party for per minute of use rate elements associated with the call transportation and termination of Local Traffic or ISP-bound Traffic.
- 7.1.4 The appropriate elemental rates set forth in Exhibit A of this Attachment shall apply for Transit Traffic as described in Sections 7.9 and 7.9.1 below and to Multiple Tandem Access as described in Section 4.10.3 above.
- 7.1.5 Neither Party shall represent Switched Access Traffic as Local Traffic or ISP-bound Traffic for purposes of payment of call transportation and termination compensation.
- 7.1.6 If Heritage assigns NPA/NXXs to specific BellSouth rate centers within the LATA and assigns numbers from those NPA/NXXs to Heritage end users physically located outside of that LATA, BellSouth traffic originating from within the LATA

where the NPA/NXXs are assigned and delivered to a Heritage customer physically located outside of such LATA, shall not be deemed Local Traffic, and no compensation from BellSouth to Heritage shall be due therefor. Further, Heritage agrees to identify such interLATA traffic to BellSouth and to compensate BellSouth for originating and transporting such interLATA traffic to Heritage at BellSouth's switched access tariff rates.

- 7.2 If Heritage does not identify such interLATA traffic to BellSouth, to the best of BellSouth's ability BellSouth will determine which whole Heritage NPA/NXXs on which to charge the applicable rates for originating network access service as reflected in BellSouth's Access Service Tariff. BellSouth shall make appropriate billing adjustments if Heritage can provide sufficient information for BellSouth to determine whether or not said traffic is Local Traffic.
- 7.3 **Percent Local Use.** Each Party shall report to the other a Percent Local Usage ("PLU"). The application of the PLU will determine the amount of local minutes to be billed to the other Party. For purposes of developing the PLU, each Party shall consider every local call and every long distance call, excluding Transit Traffic. Each Party shall update its PLU on the first of January, April, July and October of the year and shall send it to the other Party to be received no later than 30 calendar days after the first of each such month based on local usage for the past three months ending the last day of December, March, June and September, respectively. Requirements associated with PLU calculation and reporting shall be as set forth in BellSouth's Jurisdictional Factors Reporting Guide, as it is amended from time to time. Notwithstanding the foregoing, where the terminating Party has message recording technology that identifies the jurisdiction of traffic terminated as defined in this Agreement, such information, in lieu of the PLU factor, shall at the terminating Party's option be utilized to determine the appropriate local usage compensation to be paid.
- 7.4 **Percent Local Facility.** Each Party shall report to the other a Percent Local Facility ("PLF"). The application of the PLF will determine the portion of switched dedicated transport to be billed per the local jurisdiction rates. The PLF shall be applied to Multiplexing, Local Channel and Interoffice Channel Switched Dedicated Transport utilized in the provision of local interconnection trunks. Each Party shall update its PLF on the first of January, April, July and October of the year and shall send it to the other Party to be received no later than 30 calendar days after the first of each such month to be effective the first bill period the following month, respectively. Requirements associated with PLU and PLF calculation and reporting shall be as set forth in BellSouth's Jurisdictional Factors Reporting Guide, as it is amended from time to time.
- 7.5 **Percent Interstate Usage.** Each Party shall report to the other the projected Percent Interstate Usage ("PIU"). All jurisdictional report requirements, rules and regulations for Interexchange Carriers specified in BellSouth's Intrastate Access

Services Tariff will apply to Heritage. After interstate and intrastate traffic percentages have been determined by use of PIU procedures, the PLU and PLF factors will be used for application and billing of local interconnection. Each Party shall update its PIUs on the first of January, April, July and October of the year and shall send it to the other Party to be received no later than 30 calendar days after the first of each such month, for all services showing the percentages of use (PIUs, PLU, and PLF) for the past three months ending the last day of December, March, June and September. Notwithstanding the foregoing, where the terminating Party has message recording technology that identifies the jurisdiction of traffic terminated as defined in this Agreement, such information, in lieu of the PIU and PLU factors, shall at the terminating Party's option be utilized to determine the appropriate local usage compensation to be paid.

- 7.6 **Audits.** On thirty (30) days written notice, each Party must provide the other the ability and opportunity to conduct an annual audit to ensure the proper billing of traffic. BellSouth and Heritage shall retain records of call detail for a minimum of nine months from which a PLU, PLF and/or PIU can be ascertained. The audit shall be accomplished during normal business hours at an office designated by the Party being audited. Audit requests shall not be submitted more frequently than one (1) time per calendar year. Audits shall be performed by a mutually acceptable independent auditors paid for by the Party requesting the audit. The PLU and/or PIU shall be adjusted based upon the audit results and shall apply to the usage for the quarter the audit was completed, to the usage for the quarter prior to the completion of the audit, and to the usage for the two quarters following the completion of the audit. If, as a result of an audit, either Party is found to have overstated the PLU and/or PIU by twenty percentage points (20%) or more, that Party shall reimburse the auditing Party for the cost of the audit.

7.7 **Compensation for 8XX Traffic**

- 7.7.1 **Compensation for 8XX Traffic.** Each Party shall compensate the other pursuant to the appropriate switched access charges, including the database query charge as set forth in the BellSouth intrastate or interstate switched access tariffs.

- 7.7.2 **Records for 8XX Billing.** Each Party will provide to the other the appropriate records necessary for billing intraLATA 8XX customers. The records provided will be in a standard EMI format.

- 7.7.3 **8XX Access Screening.** BellSouth's provision of 8XX TFD to Heritage requires interconnection from Heritage to BellSouth 8XX SCP. Such interconnections shall be established pursuant to BellSouth's Common Channel Signaling Interconnection Guidelines and Bellcore's CCS Network Interface Specification document, TR-TSV-000905. Heritage shall establish CCS7 interconnection at the BellSouth Local Signal Transfer Points serving the BellSouth 8XX SCPs that Heritage desires to query. The terms and conditions for 8XX TFD are set out in BellSouth's Intrastate Access Services Tariff as amended.

7.8 Mutual Provision of Switched Access Service

- 7.8.1 Switched Access Traffic.** Switched Access Traffic is described in the BellSouth Access Tariff. Additionally, any Public Switched Telephone Network interexchange telecommunications traffic, regardless of transport protocol method, where the originating and terminating points, end-to-end points, are in different LATAs, or are in the same LATA and the Parties' Switched Access services are used for the origination or termination of the call, shall be considered Switched Access Traffic. Irrespective of transport protocol method used, a call which originates in one LATA and terminates in another LATA (i.e., the end-to-end points of the call) or in which the Parties' Switched Access Services are used for the origination or termination of the call, shall not be compensated as local.
- 7.8.2** If the BellSouth end user chooses Heritage as their presubscribed interexchange carrier, or if the BellSouth end user uses Heritage as an interexchange carrier on a 101XXXX basis, BellSouth will charge Heritage the appropriate BellSouth tariff charges for originating switched access services
- 7.8.3** For originating or terminating switched access traffic on the other company's network, the originating Party will pay the terminating Party BellSouth's current intrastate or interstate, whichever is appropriate, switched access tariff rates as set forth in BellSouth's Intrastate or Interstate Access Services Tariff.
- 7.8.4** When Heritage's end office switch, subtending the BellSouth Access Tandem switch for receipt or delivery of switched access traffic, provides an access service connection to or from an interexchange carrier ("IXC") by either a direct trunk group to the IXC utilizing BellSouth facilities, or via BellSouth's tandem switch, each Party will provide its own access services to the IXC and bill on a multi-bill, multi-tariff meet-point basis. Each Party will bill its own access services rates to the IXC with the exception of the interconnection charge. The interconnection charge will be billed by the Party providing the end office function. Each party will use the Multiple Exchange Carrier Access Billing (MECAB) guidelines to establish meet point billing for all applicable traffic. Thirty (30)-day billing periods will be employed for these arrangements. For tandem routed traffic, the tandem company agrees to provide to the Initial Billing Company as defined in MECAB, at no charge, all the switched access detail usage data, recorded at the access tandem, within no more than sixty (60) days after the recording date. The Initial Billing Company will provide the switched access summary usage data, for all originating and terminating traffic, to all Subsequent Billing Companies as defined in MECAB within 10 days of rendering the initial bill to the IXC. Each Party will notify the other when it is not feasible to meet these requirements so that the customers may be notified for any necessary revenue accrual associated with the significantly delayed recording or billing. As business requirements change data reporting requirements may be modified as necessary.

- 7.8.5 In the event that either Party fails to provide the appropriate MECAB switched access usage data to the other Party within 90 days after the recording date and the receiving Party is unable to bill and/or collect access revenues due to the sending Party's failure to provide such data within said time period, then the Party failing to send the data as specified herein shall be liable to the other Party in an amount equal to the unbillable or uncollectible revenues. Each company will provide complete documentation to the other to substantiate any claim of unbillable switched access revenues, and a negotiated settlement will be agreed upon between the Parties.
- 7.8.6 Each Party will retain for a minimum period of sixty (60) days, access message detail sufficient to recreate any data which is lost or damaged by their company or any third party involved in processing or transporting data.
- 7.8.7 Each Party agrees to recreate the lost or damaged data within forty-eight (48) hours of notification by the other or by an authorized third party handling the data.
- 7.8.8 Each Party also agrees to process the recreated data within forty-eight (48) hours of receipt at its data processing center.
- 7.8.9 All claims should be filed with the other Party within 120 days of the receipt of the date of the unbillable usage.
- 7.8.10 The Initial Billing Company shall keep records of its billing activities relating to jointly-provided Intrastate and Interstate access services in sufficient detail to permit the Subsequent Billing Party to, by formal or informal review or audit, to verify the accuracy and reasonableness of the jointly-provided access billing data provided by the Initial Billing Party. Each Party agrees to cooperate in such formal or informal reviews or audits and further agrees to jointly review the findings of such reviews or audits in order to resolve any differences concerning the findings thereof.
- 7.8.11 Heritage agrees not to deliver switched access traffic to BellSouth for termination except over Heritage ordered switched access trunks and facilities.
- 7.9 **Transit Traffic**
- 7.9.1 BellSouth shall provide tandem switching and transport services for Heritage's Transit Traffic. Rates for Local and ISP-bound Transit Traffic shall be the applicable Call Transport and Termination charges as set forth in Exhibit A to this Attachment. Rates for Switched Access Transit Traffic shall be the applicable charges as set forth in BellSouth Interstate or Intrastate Switched Access tariffs. Switched Access Transit Traffic presumes that Heritage's end office is subtending the BellSouth Access Tandem for switched access traffic to and from Heritage's end users utilizing BellSouth facilities, either by direct trunks with the IXC, or via the BellSouth Access Tandem. Billing associated with all Transit Traffic shall be

pursuant to MECAB guidelines. Pursuant to these guidelines, the Initial Billing Company shall provide summary usage data, for all originating and terminating Transit Traffic, to all Subsequent Billing Companies. Traffic between Heritage and Wireless Type 1 third parties shall not be treated as Transit Traffic from a routing or billing perspective. Traffic between Heritage and Wireless Type 2A or UNE-CLEC third parties shall not be treated as Transit Traffic from a routing or billing perspective until BellSouth and the Wireless carrier or UNE-CLEC third party have the capability to properly meet-point-bill in accordance with MECAB guidelines.

7.9.2 In the event that either Party fails to provide the appropriate MECAB usage data to the other Party within 90 days after the recording date and the receiving Party is unable to bill and/or collect Transit Traffic revenues due to the sending Party's failure to provide such data within said time period, then the Party failing to send the data as specified herein shall be liable to the other Party in an amount equal to the unbillable or uncollectible revenues. Each company will provide complete documentation to the other to substantiate any claim of unbillable revenues and a negotiated settlement will be agreed upon between the Parties

7.9.3 The delivery of traffic which transits the BellSouth network and is transported to another carrier's network is excluded from any BellSouth billing guarantees and will be delivered at the rates stipulated in this Agreement to a terminating carrier. BellSouth agrees to deliver this traffic to the terminating carrier; provided, however, that Heritage is solely responsible for negotiating and executing any appropriate contractual agreements with the terminating carrier for the receipt of this traffic through the BellSouth network. BellSouth will not be liable for any compensation to the terminating carrier or to Heritage. Heritage agrees to compensate BellSouth for any charges or costs for the delivery of Transit Traffic to a connecting carrier on behalf of Heritage. Additionally, the Parties agree that any billing to a third party or other telecommunications carrier under this section shall be pursuant to MECAB procedures.

8. FRAME RELAY SERVICE INTERCONNECTION

8.1 In addition to the Local Interconnection services set forth above, BellSouth will offer a network to network Interconnection arrangement between BellSouth's and Heritage's frame relay switches as set forth below. The following provisions will apply only to Frame Relay Service and Exchange Access Frame Relay Service in those states in which Heritage is certified and providing Frame Relay Service as a Local Exchange Carrier and where traffic is being exchanged between Heritage and BellSouth Frame Relay Switches in the same LATA.

8.2 The Parties agree to establish two-way Frame Relay facilities between their respective Frame Relay Switches to the mutually agreed upon Frame Relay Service point(s) of interconnection ("IP(s)") within the LATA. All IPs shall be in the same Frame Relay Network Serving Areas as defined in Section A40 of

BellSouth's General Subscriber Service Tariff except as set forth in this Attachment.

- 8.3 Upon the request of either Party, such interconnection will be established where BellSouth and Heritage have Frame Relay Switches in the same LATA. Where there are multiple Frame Relay switches in one central office, an interconnection with any one of the switches will be considered an interconnection with all of the switches at that central office for purposes of routing packet traffic.
- 8.4 The Parties agree to provision local and intraLATA Frame Relay Service and Exchange Access Frame Relay Service (both intrastate and interstate) over Frame Relay interconnection facilities between the respective Frame Relay switches and the IPs.
- 8.5 The Parties agree to assess each other reciprocal charges for the facilities that each provides to the other according to the Percent Local Circuit Use Factor (PLCU), determined as follows:
- 8.5.1 If the data packets originate and terminate in locations in the same LATA, and consistent with the local definitions of the Agreement, the traffic is considered local. Frame Relay framed packet data is transported within Virtual Circuits (VC). For the purposes of this Agreement, if all the data packets transported within a VC remain within the LATA, then consistent with the local definitions in this Agreement, the traffic on that VC is local ("Local VC").
- 8.5.2 If the originating and terminating locations of the two-way packet data traffic are not in the same LATA, the traffic on that VC is interLATA ("InterLATA VC").
- 8.5.3 The PLCU is determined by dividing the total number of Local VCs, by the total number of VCs on each Frame Relay facility. To facilitate implementation, Heritage may determine its PLCU in aggregate, by dividing the total number of Local VCs in a given LATA by the total number VCs in that LATA. The Parties agree to renegotiate the method for determining PLCU, at BellSouth's request, and within 90 days, if BellSouth notifies Heritage that it has found that this method does not adequately represent the PLCU.
- 8.5.4 If there are no VCs on a facility when it is billed, the PLCU will be zero.
- 8.5.5 BellSouth will provide the circuit between the Parties' respective Frame Relay Switches. The Parties will be compensated as follows: BellSouth will invoice, and Heritage will pay, the total non-recurring and recurring charges for the circuit based upon the rates set forth in BellSouth's Interstate Access Tariff, FCC No. 1. Heritage will then invoice, and BellSouth will pay, an amount calculated by multiplying the BellSouth billed charges for the circuit by one-half of Heritage's PLCU.

- 8.6 The Parties agree to compensate each other for Frame Relay network-to-network interface (NNI) ports based upon the NNI rates set forth in BellSouth's Interstate Access Tariff, FCC No. 1. Compensation for each pair of NNI ports will be calculated as follows: BellSouth will invoice, and Heritage will pay, the total non-recurring and recurring charges for the NNI port. Heritage will then invoice, and BellSouth will pay, an amount calculated by multiplying the BellSouth billed non-recurring and recurring charges for the NNI port by Heritage's PLCU.
- 8.7 Each Party agrees that there will be no charges to the other Party for its own subscriber's Permanent Virtual Circuit (PVC) rate elements for the local PVC segment from its Frame Relay switch to its own subscriber's premises. PVC rate elements include the Data Link Connection Identifier (DLCI) and Committed Information Rate (CIR).
- 8.8 For the PVC segment between the Heritage and BellSouth Frame Relay switches, compensation for the PVC charges is based upon the rates in BellSouth's Interstate Access Tariff, FCC No. 1.
- 8.9 Compensation for PVC rate elements will be calculated as follows:
- 8.9.1 If Heritage orders a VC connection between a BellSouth subscriber's PVC segment and a PVC segment from the BellSouth Frame Relay switch to the Heritage Frame Relay switch, BellSouth will invoice, and Heritage will pay, the total non-recurring and recurring PVC charges for the PVC segment between the BellSouth and Heritage Frame Relay switches. If the VC is a Local VC, Heritage will then invoice and BellSouth will pay, the total nonrecurring and recurring PVC charges billed for that segment. If the VC is not local, no compensation will be paid to Heritage for the PVC segment.
- 8.9.2 If BellSouth orders a Local VC connection between a Heritage subscriber's PVC segment and a PVC segment from the Heritage Frame Relay switch to the BellSouth Frame Relay switch, BellSouth will invoice, and Heritage will pay, the total non-recurring and recurring PVC and CIR charges for the PVC segment between the BellSouth and Heritage Frame Relay switches. If the VC is a Local VC, Heritage will then invoice and BellSouth will pay the total non-recurring and recurring PVC and CIR charges billed for that segment. If the VC is not local, no compensation will be paid to Heritage for the PVC segment.
- 8.9.3 The Parties agree to compensate each other for requests to change a PVC segment or PVC service order record, according to the Feature Change charge as set forth in the BellSouth access tariff BellSouth Tariff FCC No. 1.
- 8.9.4 If Heritage requests a change, BellSouth will invoice and Heritage will pay a Feature Change charge for each affected PVC segment.

- 8.9.4.1 If BellSouth requests a change to a Local VC, Heritage will invoice and BellSouth will pay a Feature Change charge for each affected PVC segment.
- 8.9.5 The Parties agree to limit the sum of the CIR for the VCs on a DS1 NNI port to not more than three times the port speed, or not more than six times the port speed on a DS3 NNI port.
- 8.9.6 Except as expressly provided herein, this Agreement does not address or alter in any way either Party's provision of Exchange Access Frame Relay Service or interLATA Frame Relay Service. All charges by each Party to the other for carriage of Exchange Access Frame Relay Service or interLATA Frame Relay Service are included in the BellSouth access tariff BellSouth Tariff FCC No. 1.
- 8.10 Heritage will identify and report quarterly to BellSouth the PLCU of the Frame Relay facilities it uses, per Section 8.5.3 above.
- 8.11 Either Party may request a review or audit of the various service components, consistent with the provisions of section E2 of the BellSouth State Access Services tariffs or Section 2 of the BellSouth FCC No.1 Tariff
- 8.12 If during the term of this Agreement, BellSouth obtains authority to provide interLATA Frame Relay in any State, the Parties agree to renegotiate this arrangement for the exchange of Frame Relay Service Traffic within one hundred eighty (180) days of the date BellSouth receives interLATA authority. In the event the Parties fail to renegotiate this Section 8 within the one hundred eighty day period, they will submit this matter to the appropriate State commission(s) for resolution.
- 9. OPERATIONAL SUPPORT SYSTEMS (OSS)**
- 9.1 The terms, conditions and rates for OSS are as set forth in FCC Tariff for Access Service Records.

Exhibit B

Basic Architecture

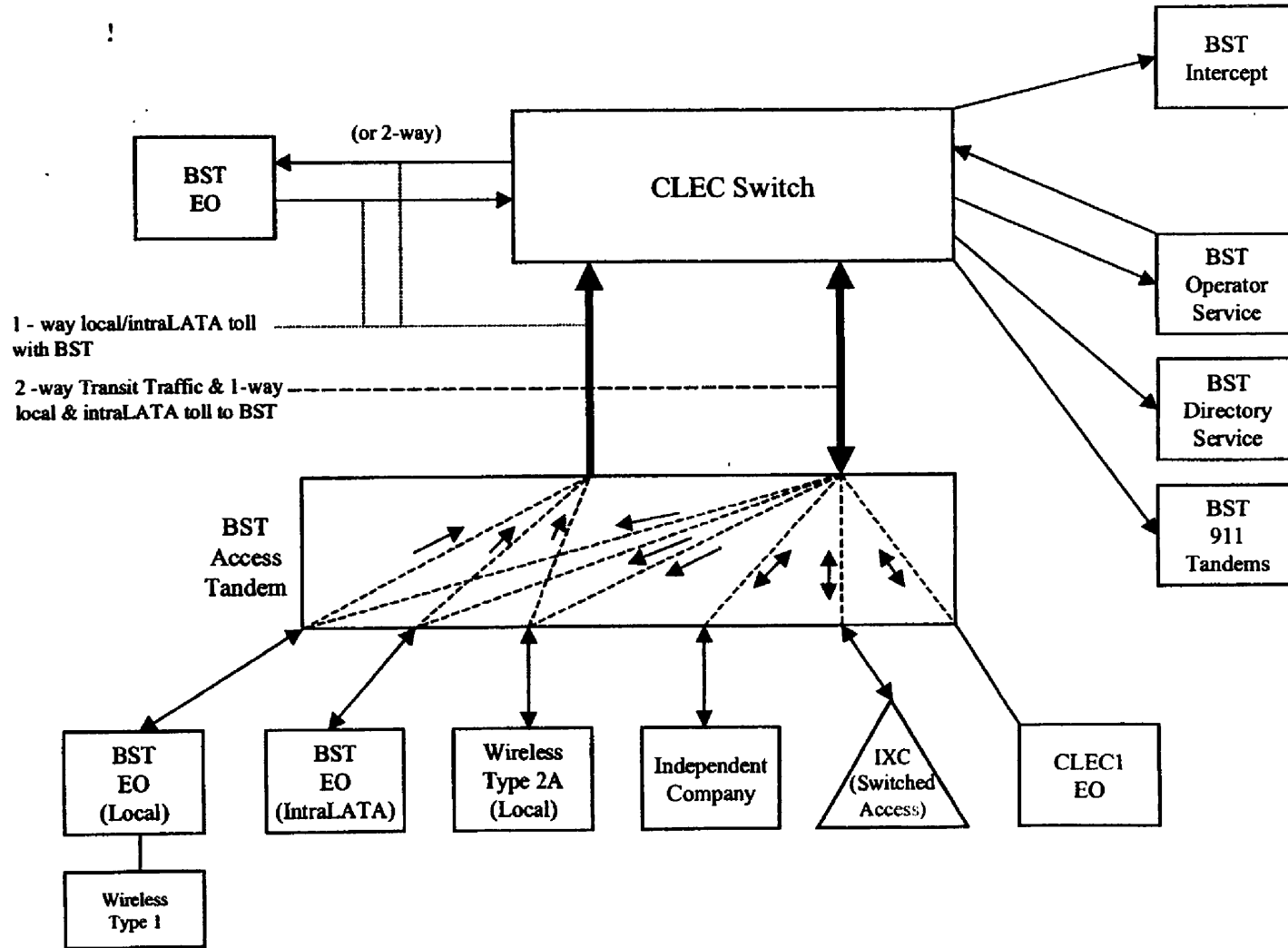

One-Way Architecture

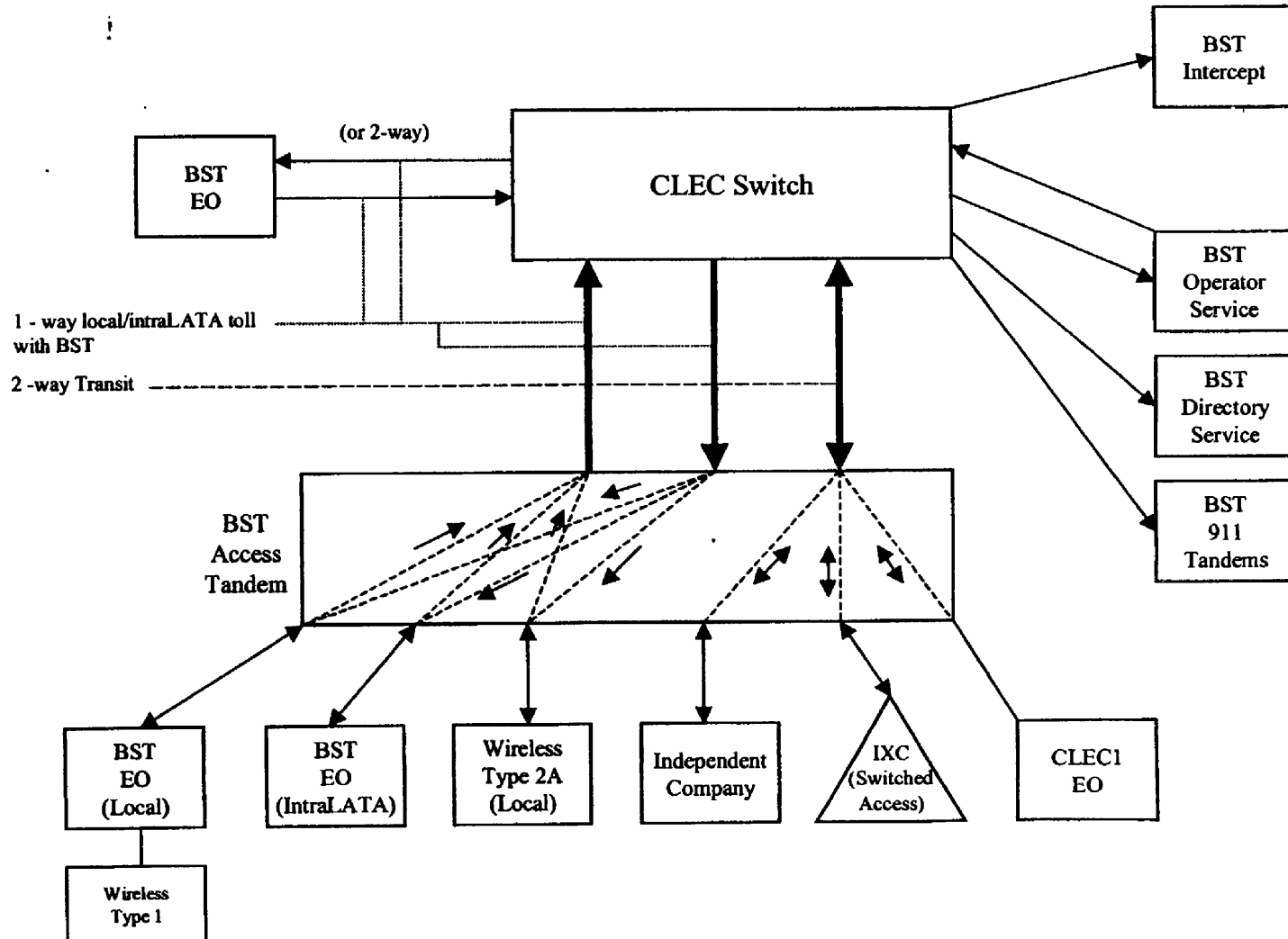
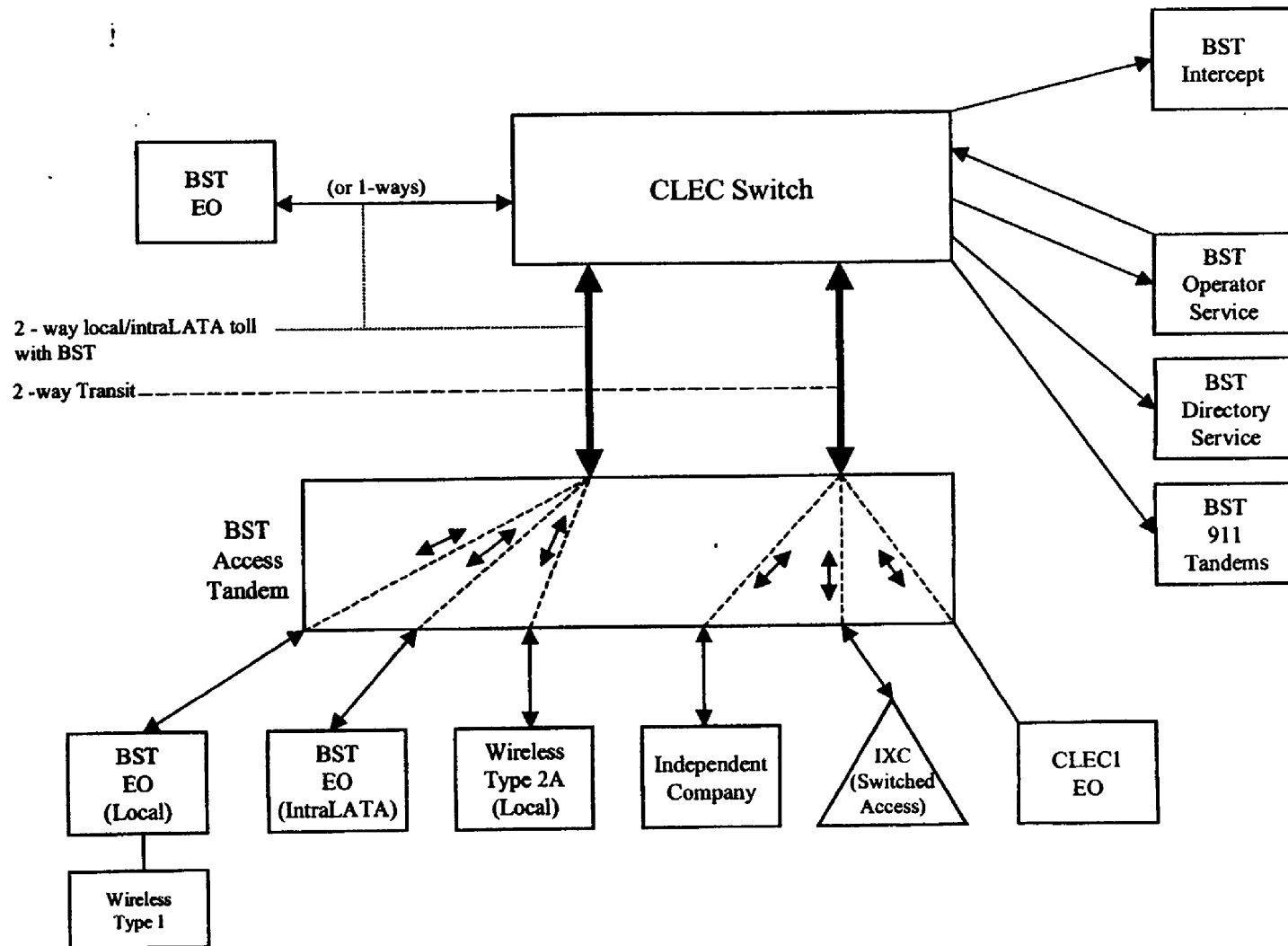
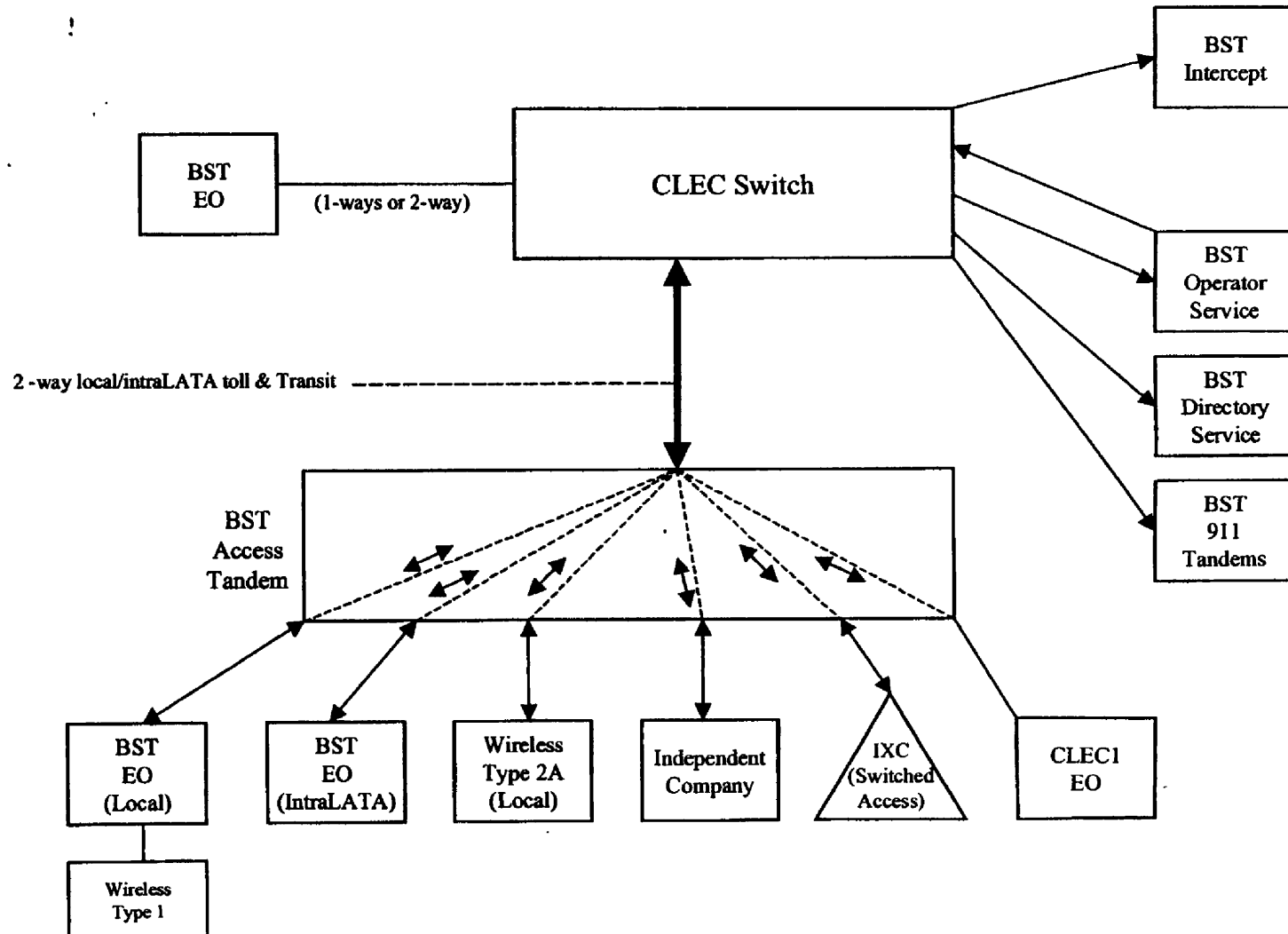

Exhibit D

Two-Way Architecture



Supergroup Architecture



LOCAL INTERCONNECTION
Florida

Attachment 3
Exhibit A

CATEGORY	NOTES	LOCAL INTERCONNECTION	Interim	Zone	SCS	USOC	RATES					OSS RATES					
							Nonrecurring			Nonrecurring		Svc Order Submitted Elec per LSR	Svc Order Submitted Monthly per LSR	Incremental Charge - Manual Svc Order vs. Electronic-1st	Incremental Charge - Manual Svc Order vs. Electronic-Add'l	Incremental Charge - Manual Svc Order vs. Electronic-Disc 1st	Incremental Charge - Manual Svc Order vs. Electronic-Disc Add'l
							Rec	First	Add'l	First	Add'l						
							Rec	First	Add'l	First	Add'l	SOMEK	SOMAN	SOMAN	SOMAN	SOMAN	SOMAN
LOCAL INTERCONNECTION (CALL TRANSPORT AND TERMINATION)																	
NOTE: "bk" beside a rate indicates that the Parties have agreed to bill and keep on usage. As such, the element will be assessed for transit and MTA traffic, and not for non-transit and non-MTA traffic.																	
TANDEM SWITCHING																	
		Tandem Switching Function Per MOU			OHD												
		Multiple Tandem Switching, per MOU (applies to initial tandem only)			OHD												
TRUNK CHARGE																	
		Installation Trunk Side Service - per DS0			OHD	TPP++		\$336.43	\$57.38								
		Dedicated End Office Trunk Port Service-per DS0**			OHD	TDE0P	\$0.00										
		Dedicated End Office Trunk Port Service-per DS1**			OH1	TDE1P	\$0.00										
		Dedicated Tandem Trunk Port Service-per DS0**			OH1MS	TDE1P	\$0.00										
		Dedicated Tandem Trunk Port Service-per DS1**			OHD	TDW0P	\$0.00										
		Dedicated Tandem Trunk Port Service-per DS1**			OH1	TDW1P	\$0.00										
** This rate element is recovered on a per MOU basis and is included in the End Office Switching and Tandem Switching, per MOU rate elements																	
LOCAL INTERCONNECTION (TRANSPORT)																	
COMMON TRANSPORT (Shared)																	
		Common Transport - Per Mile, Per MOU			OHD												
		Common Transport - Facilities Termination Per MOU			OHD												
INTEROFFICE CHANNEL - DEDICATED TRANSPORT - VOICE GRADE																	
		Interoffice Channel - Dedicated Transport - 2-Wire Voice Grade - Per Mile per month			OHL, OHM	1L5NF	\$0.0084										
		Interoffice Channel - Dedicated Transport - 2-Wire Voice Grade - Facility Termination per month			OHL, OHM	1L5NF	\$26.02	\$42.69	\$28.66	\$16.51	\$6.34						
INTEROFFICE CHANNEL - DEDICATED TRANSPORT - 56/64 KBPS																	
		Interoffice Channel - Dedicated Transport - 56 kbps - per mile per month			OHL, OHM	1L5NK	\$0.0084										
		Interoffice Channel - Dedicated Transport - 56 kbps - Facility Termination per month			OHL, OHM	1L5NK	\$18.95	\$42.69	\$28.66	\$16.51	\$6.34						
		Interoffice Channel - Dedicated Transport - 64 kbps - per mile per month			OHL, OHM	1L5NK	\$0.0084										
		Interoffice Channel - Dedicated Transport - 64 kbps - Facility Termination per month			OHL, OHM	1L5NK	\$18.95	\$42.69	\$28.66	\$16.51	\$6.34						
INTEROFFICE CHANNEL - DEDICATED TRANSPORT - DS1																	
		Interoffice Channel - Dedicated Channel - DS1 - Per Mile per month			OH1	OH1MS1L5NL	\$0.171										
		Interoffice Channel - Dedicated Transport - DS1 - Facility Termination per month			OH1	OH1MS1L5NL	\$90.87	\$95.16	\$88.78	\$16.74	\$14.85						
INTEROFFICE CHANNEL - DEDICATED TRANSPORT - DS3																	
		Interoffice Channel - Dedicated Transport - DS3 - Per Mile per month			OH3	OH3MS1L5NM	\$3.57										
		Interoffice Channel - Dedicated Transport - DS3 - Facility Termination per month			OH3	OH3MS1L5NM	\$1,101.00	\$302.43	\$197.7	\$64.94	\$63.61						

LOCAL INTERCONNECTION
Florida

Attachment 3
Exhibit A

CATEGORY	NOTES	LOCAL INTERCONNECTION	Interim	Zone	RCS	UBOC	RATES					OSS RATES							
							Nonrecurring		Nonrecurring			Svc Order Submitted Elec per LBR	Svc Order Submitted Manually per LBR	Incremental Charge - Manual Svc Order vs. Electronic-1st	Incremental Charge - Manual Svc Order vs. Electronic-Add'l	Incremental Charge - Manual Svc Order v.s. Electronic-Disc 1st	Incremental Charge - Manual Svc Order v.s. Electronic-Disc Add'l		
							Rec	First	Add'l	First	Add'l								
							Nonrecurring		Disconnect			SOMEC	SOMAN	SOMAN	SOMAN	SOMAN	SOMAN		
		LOCAL CHANNEL - DEDICATED TRANSPORT																	
		Local Channel - Dedicated - 2-Wire Voice Grade per month			OH1 OH1A	TEFV2	\$21.42	\$239.67	\$42.34	\$33.93	\$3.61								
		Local Channel - Dedicated - 4-Wire Voice Grade per month			OH1 OH1M	TEFV4	\$21.91	\$240.30	\$42.97	\$34.47	\$4.15								
		Local Channel - Dedicated - DS1 per month			OH1	TEFHG	\$34.49	\$195.33	\$165.48	\$21.90	\$15.28								
		Local Channel - Dedicated - DS3 Facility Termination per month			OH3	TEFHJ	\$554.83	\$501.59	\$308.24	\$125.43	\$87.3								
		LOCAL INTERCONNECTION MID-SPAN MEET																	
		NOTE: If Access service ride Mid-Span Meet, one-half the tariffed service Local Channel rate is applicable.																	
		Local Channel - Dedicated - DS1 per month			OH1MS	TEFHG	\$0.00	\$0.00											
		Local Channel - Dedicated - DS3 per month			OH3MS	TEFHJ	\$0.00	\$0.00											
		MULTIPLEXERS																	
		Channellization - DS1 to DS0 Channel System			OH1 OH1MS	SATN1	\$151.74	\$91.44	\$64.57	\$10.00	\$9.48								
		DS3 to DS1 Channel System per month			OH3 OH3MS	SATNS	\$218.7	\$179.68	\$106.96	\$36.37	\$35.22								
		DS3 Interface Unit (DS1 COC) per month			OH1 OH1MS	SATCO	\$14.24	\$9.08	\$6.38										
		Notes: If no rate is identified in the contract, the rate for the specific service or function will be as set forth in applicable BellSouth tariff or as negotiated by the Parties upon request by either Party.																	

Attachment 4
Physical Collocation

BELLSOUTH
PHYSICAL COLLOCATION

1. Scope of Attachment

- 1.1 The rates, terms, and conditions contained within this Attachment shall only apply when Heritage is physically collocated as a sole occupant or as a Host within a Premises location pursuant to this Attachment. This Attachment does not apply to Tennessee Caged Collocation which shall be offered pursuant to Attachment 4 – TN. BellSouth Premises include BellSouth Central Offices and Serving Wire Centers (hereinafter “Premises”). This Attachment is applicable to Premises owned or leased by BellSouth. However, if the Premises occupied by BellSouth is leased by BellSouth from a third party, special considerations and intervals may apply in addition to the terms and conditions of this Attachment.
- 1.2 **Right to Occupy.** BellSouth shall offer to Heritage collocation on rates, terms, and conditions that are just, reasonable, non-discriminatory and consistent with the rules of the Federal Communications Commission (“FCC”). Subject to the rates, terms and conditions of this Attachment where space is available and it is technically feasible, BellSouth will allow Heritage to occupy that certain area designated by BellSouth within a BellSouth Premises, or on BellSouth property upon which the BellSouth Premises is located, of a size which is specified by Heritage and agreed to by BellSouth (hereinafter “Collocation Space”). The necessary rates, terms and conditions for BellSouth locations other than BellSouth Premises shall be negotiated upon request for collocation at such location(s).
- 1.2.1 Neither BellSouth nor any of BellSouth’s affiliates may reserve space for future use on more preferential terms than those set forth below.
- 1.2.1.1 In all states other than Florida, the size specified by Heritage may contemplate a request for space sufficient to accommodate Heritage’s growth within a two-year period.
- 1.2.1.2 In the state of Florida, the size specified by Heritage may contemplate a request for space sufficient to accommodate Heritage’s growth within an eighteen (18) month period.
- 1.3 **Space Reclamation.** In the event of space exhaust within a Central Office Premises, BellSouth may include in its documentation for the Petition for Waiver filing any unutilized space in the Central Office Premises. Heritage will be responsible for any justification of unutilized space within its space, if such justification is required by the appropriate state commission.
- 1.4 **Use of Space.** Heritage shall use the Collocation Space for the purposes of installing, maintaining and operating Heritage’s equipment (to include testing and monitoring

equipment) necessary for interconnection with BellSouth services and facilities or for accessing BellSouth unbundled network elements for the provision of telecommunications services. The Collocation Space may be used for no other purposes except as specifically described herein or in any amendment hereto.

- 1.5 **Rates and Charges.** Heritage agrees to pay the rates and charges identified in Exhibit D attached hereto.
- 1.6 **Due Dates.** In all states other than Georgia, if any due date contained in this Attachment falls on a weekend or National holiday, then the due date will be the next business day thereafter.
- 1.7 The parties agree to comply with all applicable federal, state, county, local and administrative laws, rules, ordinances, regulations and codes in the performance of their obligations hereunder.
- 2. Space Availability Report**
- 2.1 **Space Availability Report.** Upon request from Heritage, BellSouth will provide a written report (“Space Availability Report”) specifying the amount of Collocation Space available at the Premises requested, the number of collocators present at the Premises, any modifications in the use of the space since the last report on the Premises requested and the measures BellSouth is taking to make additional space available for collocation arrangements.
- 2.1.1 The request from Heritage for a Space Availability Report must be written and must include the Premises street address, located in the Local Exchange Routing Guide and Common Language Location Identification (“CLLI”) code of the Premises. CLLI code information is located in the National Exchange Carriers Association (NECA) Tariff FCC No. 4.
- 2.1.2 BellSouth will respond to a request for a Space Availability Report for a particular Premises within ten (10) calendar days of receipt of such request. BellSouth will make best efforts to respond in ten (10) calendar days to such a request when the request includes from two (2) to five (5) Premises within the same state. The response time for requests of more than five (5) Premises shall be negotiated between the Parties. If BellSouth cannot meet the ten calendar day response time, BellSouth shall notify Heritage and inform Heritage of the time frame under which it can respond. In Mississippi, the above intervals shall be in business days.
- 3. Collocation Options**
- 3.1 **Cageless.** BellSouth shall allow Heritage to collocate Heritage’s equipment and facilities without requiring the construction of a cage or similar structure. BellSouth shall allow Heritage to have direct access to its equipment and facilities. BellSouth shall make cageless collocation available in single bay increments. Except where

Heritage's equipment requires special technical considerations (e.g., special cable racking, isolated ground plane, etc.), BellSouth shall assign cageless Collocation Space in conventional equipment rack lineups where feasible. For equipment requiring special technical considerations, Heritage must provide the equipment layout, including spatial dimensions for such equipment pursuant to generic requirements contained in Telcordia GR-63-Core, and shall be responsible for compliance with all special technical requirements associated with such equipment.

- 3.2 At Heritage's expense, Heritage may arrange with a contractor certified by BellSouth ("Certified Contractor") to construct a collocation arrangement enclosure in accordance with BellSouth's guidelines and specifications prior to starting equipment installation. BellSouth will provide guidelines and specifications upon request. Where local building codes require enclosure specifications more stringent than BellSouth's standard enclosure specification, Heritage and Heritage's Certified Contractor must comply with the more stringent local building code requirements. Heritage's Certified Contractor shall be responsible for filing and receiving any and all necessary permits and/or licenses for such construction. BellSouth shall cooperate with Heritage and provide, at Heritage's expense, the documentation, including architectural drawings, necessary for Heritage to obtain the zoning, permits and/or other licenses. Heritage's Certified Contractor shall bill Heritage directly for all work performed for Heritage pursuant to this Attachment and BellSouth shall have no liability for nor responsibility to pay such charges imposed by the Heritage's Certified Contractor. Heritage must provide the local BellSouth building contact with two Access Keys used to enter the locked enclosure. Except in case of emergency, BellSouth will not access Heritage's locked enclosure prior to notifying Heritage. Upon request, BellSouth shall construct the enclosure for Heritage.
- 3.2.1 BellSouth may elect to review Heritage's plans and specifications prior to allowing construction to start to ensure compliance with BellSouth's guidelines and specifications. BellSouth shall complete its review within fifteen (15) calendar days. Heritage shall be able to design caged enclosures in amounts as small as sufficient to house and maintain a single rack or bay of equipment. If BellSouth reviews Heritage's plans and specifications prior to construction, then BellSouth will have the right to inspect the enclosure after construction to make sure it is constructed according to the submitted plans and specifications. If BellSouth elects not to review Heritage's plans and specifications prior to construction, Heritage will be entitled to request BellSouth to review; and in the event Heritage does not request a BellSouth review, BellSouth shall have the right to inspect the enclosure after construction to make sure it is constructed according to BellSouth's guidelines and specifications. BellSouth may require Heritage to remove or correct within seven (7) calendar days at Heritage's expense any structure that does not meet these plans and specifications or, where applicable, BellSouth guidelines and specifications.
- 3.3 Shared (Subleased) Caged Collocation. Heritage may allow other telecommunications carriers to share Heritage's caged collocation arrangement pursuant to terms and conditions agreed to by Heritage ("Host") and other telecommunications carriers

("Guests") and pursuant to this section, except where the BellSouth Premises is located within a leased space and BellSouth is prohibited by said lease from offering such an option. Heritage shall notify BellSouth in writing upon execution of any agreement between the Host and its Guest within ten (10) calendar days (in Mississippi, ten (10) business days) of its execution and prior to any Firm Order. Further, such notice shall include the name of the Guest(s) and the term of the agreement, and shall contain a certification by Heritage that said agreement imposes upon the Guest(s) the same terms and conditions for Collocation Space as set forth in this Attachment between BellSouth and Heritage.

- 3.3.1 Heritage, as the Host shall be the sole interface and responsible Party to BellSouth for the assessment and billing of rates and charges contained within this Attachment and for the purposes of ensuring that the safety and security requirements of this Attachment are fully complied with by the Guest, its employees and agents. BellSouth shall provide Heritage with a proration of the costs of the collocation space based on the number of collocators and the space used by each. In all states other than Florida, and in addition to the foregoing, Heritage shall be the responsible party to BellSouth for the purpose of submitting Applications for initial and additional equipment placement of Guest. In the event the Host and Guest jointly submit an initial Application, only one Application Fee will be assessed. A separate initial Guest application shall require the assessment of a Subsequent Application Fee, as set forth in Exhibit D, if this Application is not the initial Application made for the arrangement. Notwithstanding the foregoing, Guest may arrange directly with BellSouth for the provision of the interconnecting facilities between BellSouth and Guest and for the provision of the services and access to unbundled network elements.
- 3.3.2 Heritage shall indemnify and hold harmless BellSouth from any and all claims, actions, causes of action, of whatever kind or nature arising out of the presence of Heritage's Guests in the Collocation Space except to the extent caused by BellSouth's sole negligence, gross negligence, or willful misconduct.
- 3.4 Adjacent Collocation. Subject to technical feasibility and space availability, BellSouth will permit adjacent collocation arrangements ("Adjacent Arrangement") on the Premises' property where physical collocation space within the Premises is legitimately exhausted, where the Adjacent Arrangement does not interfere with access to existing or planned structures or facilities on the Premises property. The Adjacent Arrangement shall be constructed or procured by Heritage and in conformance with BellSouth's design and construction specifications. Further, Heritage shall construct, procure, maintain and operate said Adjacent Arrangement(s) pursuant to all of the rates, terms and conditions set forth in this Attachment.
- 3.4.1 Should Heritage elect such option, Heritage must arrange with a Certified Contractor to construct an Adjacent Arrangement structure in accordance with BellSouth's guidelines and specifications. BellSouth will provide guidelines and specifications upon request. Where local building codes require enclosure specifications more stringent than BellSouth's standard specification, Heritage and Heritage's Certified

Contractor must comply with the more stringent local building code requirements. Heritage's Certified Contractor shall be responsible for filing and receiving any and all necessary zoning, permits and/or licenses for such construction. Heritage's Certified Contractor shall bill Heritage directly for all work performed for Heritage pursuant to this Attachment and BellSouth shall have no liability for nor responsibility to pay such charges imposed by Heritage's Certified Contractor. Heritage must provide the local BellSouth building contact with two cards, keys or other access device used to enter the locked enclosure. Except in cases of emergency, BellSouth shall not access Heritage's locked enclosure prior to notifying Heritage.

- 3.4.2 Heritage must submit its plans and specifications to BellSouth with its Firm Order. BellSouth may elect to review Heritage's plans and specifications prior to construction of an Adjacent Arrangement(s) to ensure compliance with BellSouth's guidelines and specifications. BellSouth shall complete its review within fifteen (15) calendar days. If BellSouth reviews Heritage's plans and specifications prior to construction, then BellSouth will have the right to inspect the Adjacent Arrangement after construction to make sure it is constructed according to the submitted plans and specifications. If BellSouth elects not to review Heritage's plans and specifications prior to construction, Heritage will be entitled to request BellSouth to review; and in the event Heritage does not request a BellSouth review, BellSouth shall have the right to inspect the Adjacent Arrangement after construction to make sure it is constructed according to BellSouth's guidelines and specifications. BellSouth may require Heritage to remove or correct within seven (7) calendar days at Heritage's expense any structure that does not meet these plans and specifications or, where applicable, BellSouth's guidelines and specifications.
- 3.4.3 Heritage shall provide a concrete pad, the structure housing the arrangement, heating/ventilation/air conditioning ("HVAC"), lighting, and all facilities that connect the structure (i.e. racking, conduits, etc.) to the BellSouth point of demarcation. At Heritage's option, and where the local authority having jurisdiction permits, BellSouth shall provide an AC power source and access to physical collocation services and facilities subject to the same nondiscriminatory requirements as applicable to any other physical collocation arrangement. Heritage's Certified Contractor shall be responsible, at Heritage's expense, for filing and receiving any and all necessary zoning, permits and/or licenses for such arrangement.
- 3.4.4 BellSouth shall allow Shared (Subleased) Caged Collocation within an Adjacent Arrangement pursuant to the terms and conditions set forth herein.

4. Occupancy

- 4.1 **Occupancy.** BellSouth will notify Heritage in writing that the Collocation Space is ready for occupancy ("Space Ready Date"). Heritage must notify BellSouth in writing that collocation equipment installation is complete and is operational with BellSouth's network. BellSouth may, at its option, not accept orders for cross connects until receipt of such notice. For purposes of this paragraph, Heritage's telecommunications

equipment will be deemed operational when cross-connected to BellSouth's network for the purpose of service provision.

4.2 **Termination of Occupancy.** In addition to any other provisions addressing termination of occupancy in this Agreement, Heritage may terminate occupancy in a particular Collocation Space by submitting a Subsequent Application requesting termination of occupancy. A Subsequent Application Fee will not apply for termination of occupancy. BellSouth may terminate Heritage's right to occupy the Collocation Space in the event Heritage fails to comply with any provision of this Agreement.

4.2.1 Upon termination of occupancy, Heritage at its expense shall remove its equipment and other property from the Collocation Space. Heritage shall have thirty (30) calendar days from the termination date to complete such removal, including the removal of all equipment and facilities of Heritage's Guests, unless Heritage's Guest has assumed responsibility for the collocation space housing the Guest's equipment and executed the documentation required by BellSouth prior to such removal date. Heritage shall continue payment of monthly fees to BellSouth until such date as Heritage, and if applicable Heritage's Guest, has fully vacated the Collocation Space. Should Heritage or Heritage's Guest fail to vacate the Collocation Space within thirty (30) calendar days from the termination date, BellSouth shall have the right to remove the equipment and other property of Heritage or Heritage's Guest at Heritage's expense and with no liability for damage or injury to Heritage or Heritage's Guest's property unless caused by the gross negligence or intentional misconduct of BellSouth. Upon termination of Heritage's right to occupy Collocation Space, Heritage shall surrender such Collocation Space to BellSouth in the same condition as when first occupied by Heritage except for ordinary wear and tear, unless otherwise agreed to by the Parties. Heritage or Heritage's BellSouth Certified Vendor shall be responsible for updating and making any necessary changes to BellSouth's records as required by BellSouth's guidelines and specifications including but not limited to Central Office Record Drawings, ERMA, TIRKS, LFACS, LMOS, COSMOS and TEOSPS DSX Records. Heritage shall be responsible for the cost of removing any enclosure, together with all support structures (e.g., racking, conduits, etc.), at the termination of occupancy and restoring the grounds to their original condition.

5. **Use of Collocation Space**

5.1 **Equipment Type.** BellSouth permits the collocation of any type of equipment necessary for interconnection to BellSouth's network or for access to BellSouth's unbundled network elements in the provision of telecommunications services.

5.1.1 Such equipment must at a minimum meet the following BellCore (Telcordia) Network Equipment Building Systems (NEBS) General Equipment Requirements: Criteria Level 1 requirements as outlined in the BellCore (Telcordia) Special Report SR-3580, Issue 1; equipment design spatial requirements per GR-63-CORE, Section 2; thermal heat dissipation per GR-063-CORE, Section 4, Criteria 77-79; acoustic noise per GR-063-CORE, Section 4, Criterion 128, and National Electric Code standards. Except

where otherwise required by a Commission, BellSouth shall comply with the applicable FCC rules relating to denial of collocation based on Heritage's failure to comply with this section.

- 5.1.2 Heritage shall not request more DS0, DS1, DS3 and optical terminations for a collocation arrangement than the total port or termination capacity of the transmission equipment physically installed in the arrangement. The total capacity of the transmission equipment collocated in the arrangement will include equipment contained in the application in question as well as equipment already placed in the arrangement. Collocated cross-connect devices are not considered transmission equipment. If full network termination capacity of the transmission equipment being installed is not requested in the application, additional network terminations for the installed equipment will require the submission of another application. In the event that Heritage submits an application for terminations that exceed the total capacity of the collocated equipment, Heritage will be informed of the discrepancy and will be required to submit a revision to the application.
- 5.2 Heritage shall not use the Collocation Space for marketing purposes nor shall it place any identifying signs or markings outside the Collocation Space or on the grounds of the Premises.
- 5.3 Heritage shall place a plaque or other identification affixed to Heritage's equipment necessary to identify Heritage's equipment, including a list of emergency contacts with telephone numbers.
- 5.4 Entrance Facilities. Heritage may elect to place Heritage-owned or Heritage-leased fiber entrance facilities into the Collocation Space. BellSouth will designate the point of interconnection in close proximity to the Premises building housing the Collocation Space, such as an entrance manhole or a cable vault which are physically accessible by both Parties. Heritage will provide and place fiber cable at the point of entrance of sufficient length to be pulled through conduit and into the splice location. Heritage will provide and install a sufficient length of fire retardant riser cable, to which the entrance cable will be spliced by BellSouth, which will extend from the splice location to Heritage's equipment in the Collocation Space. In the event Heritage utilizes a non-metallic, riser-type entrance facility, a splice will not be required. Heritage must contact BellSouth for instructions prior to placing the entrance facility cable in the manhole. Heritage is responsible for maintenance of the entrance facilities. At Heritage's option BellSouth will accommodate where technically feasible a microwave entrance facility pursuant to separately negotiated terms and conditions. In the case of adjacent collocation, unless BellSouth determines that limited space is available for the entrance facilities, copper facilities may be used between the adjacent collocation arrangement and the central office demarcation point.
- 5.4.1 Dual Entrance. BellSouth will provide at least two interconnection points at each Premises where there are at least two such interconnection points available and where capacity exists. Upon receipt of a request for physical collocation under this

Attachment, BellSouth shall provide Heritage with information regarding BellSouth's capacity to accommodate dual entrance facilities. If conduit in the serving manhole(s) is available and is not reserved for another purpose for utilization within 12 months of the receipt of an application for collocation, BellSouth will make the requested conduit space available for installing a second entrance facility to Heritage's arrangement. The location of the serving manhole(s) will be determined at the sole discretion of BellSouth. Where dual entrance is not available due to lack of capacity, BellSouth will so state in the Application Response.

- 5.4.2 **Shared Use.** Heritage may utilize spare capacity on an existing interconnector entrance facility for the purpose of providing an entrance facility to Heritage's collocation arrangement within the same BellSouth Premises. BellSouth shall allow the splice, provided that the fiber is non-working fiber. Heritage must arrange with BellSouth for BellSouth to splice the Heritage provided riser cable to the spare capacity on the entrance facility. The rates set forth in Exhibit D will apply.
- 5.5 **Demarcation Point.** BellSouth will designate the point(s) of demarcation between Heritage's equipment and/or network and BellSouth's network. Each Party will be responsible for maintenance and operation of all equipment/facilities on its side of the demarcation point. For 2-wire and 4-wire connections to BellSouth's network, the demarcation point shall be a common block on the BellSouth designated conventional distributing frame. Heritage shall be responsible for providing, and a supplier certified by BellSouth ("Certified Supplier") shall be responsible for installing and properly labeling/stenciling, the common block, and necessary cabling pursuant to Section 6. For all other terminations BellSouth shall designate a demarcation point on a per arrangement basis. Heritage or its agent must perform all required maintenance to equipment/facilities on its side of the demarcation point, pursuant to Section 5.6, following, and may self-provision cross-connects that may be required within the Collocation Space to activate service requests. At Heritage's option and expense, a Point of Termination ("POT") bay or frame may be placed in the Collocation Space, but will not serve as the demarcation point. Heritage must make arrangements with a Certified Supplier for such placement.
- 5.6 **Heritage's Equipment and Facilities.** Heritage, or if required by this Attachment, Heritage's Certified Supplier, is solely responsible for the design, engineering, installation, testing, provisioning, performance, monitoring, maintenance and repair of the equipment and facilities used by Heritage which must be performed in compliance with all applicable BellSouth policies and guidelines. Such equipment and facilities may include but are not limited to cable(s); equipment; and point of termination connections. Heritage and its selected Certified Supplier must follow and comply with all BellSouth requirements outlined in BellSouth's TR 73503, TR 73519, TR 73572, and TR 73564.
- 5.7 **BellSouth's Access to Collocation Space.** From time to time BellSouth may require access to the Collocation Space. BellSouth retains the right to access such space for the purpose of making BellSouth equipment and building modifications (e.g., running,

altering or removing racking, ducts, electrical wiring, HVAC, and cables). BellSouth will give notice to Heritage at least 48 hours before access to the Collocation Space is required. Heritage may elect to be present whenever BellSouth performs work in the Collocation Space. The Parties agree that Heritage will not bear any of the expense associated with this work.

- 5.8 **Access.** Pursuant to Section 11, Heritage shall have access to the Collocation Space twenty-four (24) hours a day, seven (7) days a week. Heritage agrees to provide the name and social security number or date of birth or driver's license number of each employee, contractor, or agents of Heritage or Heritage's Guests provided with access keys or devices ("Access Keys") prior to the issuance of said Access Keys. Key acknowledgement forms must be signed by Heritage and returned to BellSouth Access Management within 15 calendar days of Heritage's receipt. Failure to return properly acknowledged forms will result in the holding of subsequent requests until acknowledgements are current. Access Keys shall not be duplicated under any circumstances. Heritage agrees to be responsible for all Access Keys and for the return of all said Access Keys in the possession of Heritage employees, contractors, Guests, or agents after termination of the employment relationship, contractual obligation with Heritage or upon the termination of this Attachment or the termination of occupancy of an individual collocation arrangement.
- 5.8.1 BellSouth will permit one accompanied site visit to Heritage's designated collocation arrangement location after receipt of the Bona Fide Firm Order without charge to Heritage. Heritage must submit to BellSouth the completed Access Control Request Form for all employees or agents requiring access to the BellSouth Premises a minimum of 30 calendar days prior to the date Heritage desires access to the Collocation Space. In order to permit reasonable access during construction of the Collocation Space, Heritage may submit such a request at any time subsequent to BellSouth's receipt of the Bona Fide Firm Order. In the event Heritage desires access to the Collocation Space after submitting such a request but prior to access being approved, in addition to the first accompanied free visit, BellSouth shall permit Heritage to access the Collocation Space accompanied by a security escort at Heritage's expense. Heritage must request escorted access at least three (3) business days prior to the date such access is desired.
- 5.9 **Lost or Stolen Access Keys.** Heritage shall notify BellSouth in writing within 24 hours of becoming aware in the case of lost or stolen Access Keys. Should it become necessary for BellSouth to re-key buildings or deactivate a card as a result of a lost Access Key(s) or for failure to return an Access Key(s), Heritage shall pay for all reasonable costs associated with the re-keying or deactivating the card.
- 5.10 **Interference or Impairment.** Notwithstanding any other provisions of this Attachment, Heritage shall not use any product or service provided under this Agreement, any other service related thereto or used in combination therewith, or place or use any equipment or facilities in any manner that 1) significantly degrades, interferes with or impairs service provided by BellSouth or by any other entity or any person's use of its

telecommunications service; 2) endangers or damages the equipment, facilities or other property of BellSouth or of any other entity or person; 3) compromises the privacy of any communications; or 4) creates an unreasonable risk of injury or death to any individual or to the public. If BellSouth reasonably determines that any equipment or facilities of Heritage violates the provisions of this paragraph, BellSouth shall give written notice to Heritage, which notice shall direct Heritage to cure the violation within forty-eight (48) hours of Heritage's actual receipt of written notice or, at a minimum, to commence curative measures within 24 hours and to exercise reasonable diligence to complete such measures as soon as possible thereafter. After receipt of the notice, the Parties agree to consult immediately and, if necessary, to inspect the arrangement.

- 5.10.1 Except in the case of the deployment of an advanced service which significantly degrades the performance of other advanced services or traditional voice band services, if Heritage fails to take curative action within 48 hours or if the violation is of a character which poses an immediate and substantial threat of damage to property, injury or death to any person, or any other significant degradation, interference or impairment of BellSouth's or another entity's service, then and only in that event BellSouth may take such action as it deems appropriate to correct the violation, including without limitation the interruption of electrical power to Heritage's equipment. BellSouth will endeavor, but is not required, to provide notice to Heritage prior to taking such action and shall have no liability to Heritage for any damages arising from such action, except to the extent that such action by BellSouth constitutes willful misconduct.
- 5.10.2 For purposes of this Section, the term significantly degrade shall mean an action that noticeably impairs a service from a user's perspective. In the case of the deployment of an advanced service which significantly degrades the performance of other advanced services or traditional voice band services and Heritage fails to take curative action within 48 hours then BellSouth will establish before the relevant Commission that the technology deployment is causing the significant degradation. Any claims of network harm presented to Heritage or, if subsequently necessary, the relevant Commission, must be supported with specific and verifiable information. Where BellSouth demonstrates that a deployed technology is significantly degrading the performance of other advanced services or traditional voice band services, Heritage shall discontinue deployment of that technology and migrate its customers to technologies that will not significantly degrade the performance of other such services. Where the only degraded service itself is a known disturber, and the newly deployed technology satisfies at least one of the criteria for a presumption that is acceptable for deployment under section 47 C.F.R. 51.230, the degraded service shall not prevail against the newly-deployed technology.
- 5.11 Personalty and its Removal. Facilities and equipment placed by Heritage in the Collocation Space shall not become a part of the Collocation Space, even if nailed, screwed or otherwise fastened to the Collocation Space, but shall retain their status as personal property and may be removed by Heritage at any time. Any damage caused

to the Collocation Space by Heritage's employees, agents or representatives during the removal of such property shall be promptly repaired by Heritage at its expense.

- 5.12 **Alterations.** In no case shall Heritage or any person acting on behalf of Heritage make any rearrangement, modification, improvement, addition, or other alteration which could affect in any way space, power, HVAC, and/or safety considerations to the Collocation Space or the BellSouth Premises without the written consent of BellSouth, which consent shall not be unreasonably withheld. The cost of any such specialized alterations shall be paid by Heritage. Any such material rearrangement, modification, improvement, addition, or other alteration shall require a Subsequent Application and Subsequent Application Fee.
- 5.13 **Janitorial Service.** Heritage shall be responsible for the general upkeep of the Collocation Space. Heritage shall arrange directly with a BellSouth Certified Contractor for janitorial services applicable to Caged Collocation Space. BellSouth shall provide a list of such contractors on a site-specific basis upon request.

6. Ordering and Preparation of Collocation Space

- 6.1 Should any state or federal regulatory agency impose procedures or intervals applicable to Heritage that are different from procedures or intervals set forth in this section, whether now in effect or that become effective after execution of this Agreement, those procedures or intervals shall supersede the requirements set forth herein for that jurisdiction for all applications submitted for the first time after the effective date thereof.
- 6.2 **Initial Application.** For Heritage or Heritage's Guest(s) initial equipment placement, Heritage shall submit to BellSouth a Physical Expanded Interconnection Application Document ("Application"). The Application is Bona Fide when it is complete and accurate, meaning that all required fields on the application are completed with the appropriate type of information. An application fee will apply.
- 6.3 **Subsequent Application.** In the event Heritage or Heritage's Guest(s) desires to modify the use of the Collocation Space after Bona Fide Firm Order, Heritage shall complete an Application detailing all information regarding the modification to the Collocation Space ("Subsequent Application"). BellSouth shall determine what modifications, if any, to the Premises are required to accommodate the change requested by Heritage in the Application. Such necessary modifications to the Premises may include, but are not limited to, floor loading changes, changes necessary to meet HVAC requirements, changes to power plant requirements, equipment additions, etc.
- 6.3.1 **Subsequent Application Fee.** The application fee paid by Heritage for its request to modify the use of the Collocation Space shall be dependent upon the level of assessment needed for the modification requested. Where the Subsequent Application

does not require assessment for provisioning or construction work by BellSouth, no Subsequent Application fee will be required. The fee for a Subsequent Application where the modification requested has limited effect (e.g., requires limited assessment and no capital expenditure by BellSouth) shall be the Subsequent Application Fee as set forth in Exhibit D. If the modification requires capital expenditure assessment, a full Application Fee shall apply. The Subsequent Application is Bona Fide when it is complete and accurate, meaning that all required fields on the Application are completed with the appropriate type of information.

6.4 Space Availability Notification.

6.4.1 Unless otherwise specified, BellSouth will respond to an application within ten (10) calendar days (In Mississippi, ten (10) business days) as to whether space is available or not available within a BellSouth Premises. BellSouth will also respond as to whether the Application is Bona Fide and if it is not Bona Fide the items necessary to cause the Application to become Bona Fide. With the exception of Georgia, this interval excludes National Holidays. If the amount of space requested is not available, BellSouth will notify Heritage of the amount of space that is available and no Application Fee shall apply. When BellSouth's response includes an amount of space less than that requested by Heritage, or differently configured, Heritage must resubmit its Application to reflect the actual space available.

6.4.2 BellSouth will respond to a Florida Application within fifteen (15) calendar days as to whether space is available or not available within a BellSouth Premises. BellSouth will also respond as to whether the Application is Bona Fide and if it is not Bona Fide the items necessary to cause the Application to become Bona Fide. If a lesser amount of space than requested is available, BellSouth will provide an Application Response for the amount of space that is available and an Application Fee will be assessed. When BellSouth's Application Response includes an amount of space less than that requested by Heritage or differently configured, Heritage must amend its Application to reflect the actual space available prior to submitting Bona Fide Firm Order.

6.4.3 BellSouth will respond to a Louisiana Application within ten (10) calendar days for space availability for one (1) to ten (10) Applications; fifteen (15) calendar days for eleven (11) to twenty (20) Applications; and for more than twenty (20) Applications, it is increased by five (5) calendar days for every five additional Applications received within five (5) business days. If the amount of space requested is not available, BellSouth will notify Heritage of the amount of space that is available and no Application Fee shall apply. When BellSouth's response includes an amount of space less than that requested by Heritage or differently configured, Heritage must resubmit its Application to reflect the actual space available. BellSouth will also respond as to whether the Application is Bona Fide and if it is not Bona Fide the items necessary to cause the Application to become Bona Fide.

6.5 Denial of Application. If BellSouth notifies Heritage that no space is available ("Denial of Application"), BellSouth will not assess an Application Fee. After

notifying Heritage that BellSouth has no available space in the requested Premises, BellSouth will allow Heritage, upon request, to tour the entire Premises within ten (10) calendar days of such Denial of Application. In order to schedule said tour within ten (10) calendar days, the request for a tour of the Premises must be received by BellSouth within five (5) calendar days of the Denial of Application. In Mississippi, the above intervals shall be in business days.

- 6.6 Filing of Petition for Waiver. Upon Denial of Application BellSouth will timely file a petition with the Commission pursuant to 47 U.S.C. § 251(c)(6). BellSouth shall provide to the Commission any information requested by that Commission. Such information shall include which space, if any, BellSouth or any of BellSouth's affiliates have reserved for future use and a detailed description of the specific future uses for which the space has been reserved. Subject to an appropriate nondisclosure agreement or provision, BellSouth shall permit Heritage to inspect any floor plans or diagrams that BellSouth provides to the Commission.
- 6.7 Waiting List. On a first-come, first-served basis governed by the date of receipt of an Application or Letter of Intent, BellSouth will maintain a waiting list of requesting carriers who have either received a Denial of Application or, where it is publicly known that the Premises is out of space, have submitted a Letter of Intent to collocate. BellSouth will notify the telecommunications carriers on the waiting list that can be accommodated by the amount of space that becomes available according to the position of the telecommunications carriers on said waiting list.
- 6.7.1 In Florida, on a first-come, first-served basis governed by the date of receipt of an Application or Letter of Intent, BellSouth will maintain a waiting list of requesting carriers who have either received a Denial of Application or, where it is publicly known that the Premises is out of space, have submitted a Letter of Intent to collocate. Sixty (60) days prior to space becoming available, if known, BellSouth will notify the Florida PSC and the telecommunications carriers on the waiting list by mail when space becomes available according to the position of telecommunications carrier on said waiting list. If not known sixty (60) days in advance, BellSouth shall notify the Florida PSC and the telecommunications carriers on the waiting list within two days of the determination that space is available. A CLEC that, upon denial of physical collocation, requests virtual collocation shall be automatically placed on the waiting list.
- 6.7.2 When space becomes available, Heritage must submit an updated, complete, and correct Application to BellSouth within 30 calendar days (in Mississippi, 30 business days) of such notification. If Heritage has originally requested caged collocation space and cageless collocation space becomes available, Heritage may refuse such space and notify BellSouth in writing within that time that Heritage wants to maintain its place on the waiting list without accepting such space. Heritage may accept an amount of space less than its original request by submitting an Application as set forth above, and upon request, may maintain its position on the waiting list for the remaining space that was initially requested. If Heritage does not submit such an Application or notify BellSouth in writing as described above, BellSouth will offer such space to the next

CLEC on the waiting list and remove Heritage from the waiting list. Upon request, BellSouth will advise Heritage as to its position on the list.

- 6.8 **Public Notification.** BellSouth will maintain on its Interconnection Services website a notification document that will indicate all Central Offices that are without available space. BellSouth shall update such document within ten (10) calendar days (in Mississippi, 10 business days) of the Denial of Application due to Space Exhaust. BellSouth will also post a document on its Interconnection Services website that contains a general notice where space has become available in a Central Office previously on the space exhaust list.
- 6.9 **Application Response.**
- 6.9.1 In Alabama, Kentucky, North Carolina, and Tennessee, when space has been determined to be available, BellSouth will provide a written response (“Application Response”) within twenty-three (23) business days of the receipt of a Bona Fide Application, which will include, at a minimum, the configuration of the space, the Cable Installation Fee, Cable Records Fee, and the space preparation fees, as described in Section 8.
- 6.9.2 Except as otherwise provided, for all States that have ordered provisioning intervals but not application response intervals, BellSouth will provide a written response (“Application Response”) within thirty (30) calendar days of receipt of a Bona Fide Application. The Application Response will include, at a minimum, the configuration of the space, the Cable Installation Fee, Cable Records Fee, and the space preparation fees, as described in Section 8. When multiple applications are submitted in a state within a fifteen (15) calendar day window, BellSouth will respond to the Bona Fide Applications as soon as possible, but no later than the following: within thirty (30) calendar days for Bona Fide Applications one (1) to five (5); within thirty-six (36) calendar days for Bona Fide Applications six (6) to ten (10); within forty-two (42) calendar days for Bona Fide Applications eleven (11) to fifteen (15). Response intervals for multiple Bona Fide Applications submitted within the same timeframe for the same state in excess of fifteen (15) must be negotiated. All negotiations shall consider the total volume from all requests from telecommunications companies for collocation.
- 6.9.3 In Florida, within fifteen (15) calendar days of receipt of a Bona Fide Application, when space has been determined to be available or when a lesser amount of space than that requested is available, then with respect to the space available, BellSouth will provide a written response (“Application Response”) including sufficient information to enable Heritage to place a Firm Order. The Application Response will include, at a minimum, the configuration of the space, the Cable Installation Fee, Cable Records Fee, and the space preparation fees, as described in Section 8. When Heritage submits ten (10) or more Applications within ten (10) calendar days, the initial fifteen (15) day response period will increase by ten (10) days for every additional ten (10) Applications or fraction thereof.

- 6.9.4 In Georgia, when space has been determined to be available for caged or cageless arrangements, BellSouth will provide a written response ("Application Response") within thirty (30) calendar days of receipt of a Bona Fide Application. The Application Response will include, at a minimum, the configuration of the space, the Cable Installation Fee, Cable Records Fee, and the space preparation fees, as described in Section 8.
- 6.9.5 In Mississippi, when space has been determined to be available, BellSouth will provide a written response ("Application Response") within thirty (30) business days of receipt of a Bona Fide Application. The Application Response will include, at a minimum, the configuration of the space, the Cable Installation Fee, Cable Records Fee, and the space preparation fees, as described in Section 8. When multiple applications are submitted in a state within a fifteen (15) business day window, BellSouth will respond to the Bona Fide Applications as soon as possible, but no later than the following: within thirty (30) business days for Bona Fide Applications one (1) to five (5); within thirty-six (36) business days for Bona Fide Applications six (6) to ten (10); within forty-two (42) business days for Bona Fide Applications eleven (11) to fifteen (15). Response intervals for multiple Bona Fide Applications submitted within the same timeframe for the same state in excess of fifteen (15) must be negotiated. All negotiations shall consider the total volume from all requests from telecommunications companies for collocation.
- 6.9.6 In Louisiana, when space has been determined to be available, BellSouth will provide a written response ("Application Response") within thirty (30) calendar days for one (1) to ten (10) Applications; thirty-five (35) calendar days for eleven (11) to twenty (20) Applications; and for requests of more than twenty (20) Application it is increased by five (5) calendar days for every five (5) Applications received within five (5) business days. The Application Response will include, at a minimum, the configuration of the space, the Cable Installation Fee, Cable Records Fee, and the space preparation fees, as described in Section 8.
- 6.10 Application Modifications.
- 6.10.1 If a modification or revision is made to any information in the Bona Fide Application prior to Bona Fide Firm Order, with the exception of modifications to Customer Information, Contact Information or Billing Contact Information, either at the request of Heritage or necessitated by technical considerations, said Application shall be considered a new Application and shall be handled as a new Application with respect to response and provisioning intervals and BellSouth may charge Heritage an application fee. Where the Application Modification does not require assessment for provisioning or construction work by BellSouth, no application fee will be required. The fee for an Application Modification where the modification requested has limited effect (e.g., requires limited assessment and no capital expenditure by BellSouth) shall be the Subsequent Application Fee as set forth in Exhibit D. Major changes such as

requesting additional space or adding equipment may require Heritage to submit the Application with an Application Fee.

6.11 **Bona Fide Firm Order.**

- 6.11.1 In Alabama, Kentucky, North Carolina, and Tennessee, Heritage shall indicate its intent to proceed with equipment installation in a BellSouth Premises by submitting a Physical Expanded Interconnection Firm Order document ("Firm Order") to BellSouth. A Firm Order shall be considered Bona Fide when Heritage has completed the Application/Inquiry process described in Section 6.2, preceding, and has submitted the Firm Order document indicating acceptance of the Application Response provided by BellSouth. The Bona Fide Firm Order must be received by BellSouth no later than five (5) business days after BellSouth's Application Response to Heritage's Bona Fide Application.
- 6.11.2 Except as otherwise provided, in all States that have ordered provisioning intervals but not addressed Firm Order intervals, the following shall apply. Heritage shall indicate its intent to proceed with equipment installation in a BellSouth Premises by submitting a Firm Order to BellSouth. The Bona Fide Firm Order must be received by BellSouth no later than thirty (30) calendar days after BellSouth's Application Response to Heritage's Bona Fide Application or the Application will expire.
- 6.11.3 In Mississippi, Heritage shall indicate its intent to proceed with equipment installation in a BellSouth Premises by submitting a Firm Order to BellSouth. The Bona Fide Firm Order must be received by BellSouth no later than thirty (30) business days after BellSouth's Application Response to Heritage's Bona Fide Application or the Application will expire.
- 6.11.4 BellSouth will establish a firm order date based upon the date BellSouth is in receipt of a Bona Fide Firm Order. BellSouth will acknowledge the receipt of Heritage's Bona Fide Firm Order within seven (7) calendar days of receipt indicating that the Bona Fide Firm Order has been received. A BellSouth response to a Bona Fide Firm Order will include a Firm Order Confirmation containing the firm order date. No revisions will be made to a Bona Fide Firm Order.

7. **Construction and Provisioning**

7.1 **Construction and Provisioning Intervals**

- 7.1.1 In Alabama (Caged Only), Kentucky, North Carolina and Tennessee, BellSouth will complete construction for collocation arrangements within seventy-six (76) business days from receipt of an Application or as agreed to by the Parties. Under extraordinary conditions, BellSouth will complete construction for collocation arrangements within ninety-one (91) business days. Examples of extraordinary conditions include, but are not limited to, extended license or permitting intervals; major BellSouth equipment rearrangement or addition; power plant addition or

upgrade; major mechanical addition or upgrade; major upgrade for ADA compliance; environmental hazard or hazardous materials abatement; and arrangements for which equipment shipping intervals are extraordinary in length. In the event Heritage submits a forecast as described in the following section three (3) months or more prior to the application date, the above intervals shall apply. In the event Heritage submits such a forecast between two (2) months and three (3) months prior to the application date, the above intervals may be extended by one (1) additional month. In the event Heritage submits such a forecast less than two (2) months prior to the application date, the above intervals may be extended by sixty (60) calendar days. BellSouth will attempt to meet standard intervals for unforecasted requests and any interval adjustments will be discussed with Heritage at the time the application is received. Raw space, which is space lacking the necessary infrastructure to provide collocation space including but not limited to HVAC, Power, etc.), conversion time frames fall outside the normal intervals and are negotiated on an individual case basis. Additionally, installations to existing collocation arrangements for line sharing or line splitting, which include adding cable, adding cable and splitter, and adding a splitter, will be forty five (45) business days from receipt of an Application.

- 7.1.1.1 To be considered a timely and accurate forecast, Heritage must submit to BellSouth the CLEC Forecast Form, as set forth in exhibit C attached hereto, containing the following information: Central Office/Serving Wire Center CLLI, number of Caged square feet and/or Cageless bays, number of DS0, DS1, DS3 frame terminations, number of fused amps and planned application date.
- 7.1.2 In Alabama, BellSouth will complete construction for cageless collocation arrangements under ordinary conditions as soon as possible and within a maximum of sixty (60) calendar days from receipt of a Bona Fide Firm Order and ninety (90) calendar days for extraordinary conditions or as agreed to by the Parties. Ordinary conditions are defined as space available with only minor changes to support systems required, such as but not limited to, HVAC, cabling and the power plant(s). Extraordinary conditions are defined to include but are not limited to major BellSouth equipment rearrangement or addition; power plant addition or upgrade; major mechanical addition or upgrade; major upgrade for ADA compliance; environmental hazard or hazardous materials abatement; and arrangements for which equipment shipping intervals are extraordinary in length. The Parties may mutually agree to renegotiate an alternative provisioning interval or BellSouth may seek a waiver from this interval from the Commission.
- 7.1.3 In Florida, BellSouth will complete construction for collocation arrangements as soon as possible and within a maximum of ninety (90) calendar days from receipt of a Bona Fide Firm Order or as agreed to by the Parties. For changes to collocation space after initial space completion ("Augmentation"), BellSouth will complete construction for collocation arrangements as soon as possible and within a maximum of forty-five (45) calendar days from receipt of a Bona Fide Firm Order or as agreed to by the Parties. If BellSouth does not believe that construction will be completed within the relevant time frame and BellSouth and Heritage cannot agree upon a completion date, within forty-five (45) calendar days of receipt of the Bona Fide Firm Order for an initial

request, and within thirty (30) calendar days for Augmentations, BellSouth may seek an extension from the Florida PSC.

- 7.1.4 In Georgia, BellSouth will complete construction for caged collocation arrangements under ordinary conditions as soon as possible and within a maximum of ninety (90) calendar days from receipt of a Bona Fide Firm Order or as agreed to by the Parties. BellSouth will complete construction for cageless collocation arrangements under ordinary conditions as soon as possible and within a maximum of sixty (60) calendar days from receipt of a Bona Fide Firm Order and ninety (90) calendar days for extraordinary conditions or as agreed to by the Parties. Ordinary conditions are defined as space available with only minor changes to support systems required, such as but not limited to, HVAC, cabling and the power plant(s). Extraordinary conditions are defined to include but are not limited to major BellSouth equipment rearrangement or addition; power plant addition or upgrade; major mechanical addition or upgrade; major upgrade for ADA compliance; environmental hazard or hazardous materials abatement; and arrangements for which equipment shipping intervals are extraordinary in length. The Parties may mutually agree to renegotiate an alternative provisioning interval or BellSouth may seek a waiver from this interval from the Commission.
- 7.1.5 In Louisiana, BellSouth will complete construction for collocation arrangements under ordinary conditions as soon as possible and within a maximum of ninety (90) calendar days from receipt of a Bona Fide Firm Order for an initial request, and within sixty (60) calendar days for an Augmentation, or as agreed to by the Parties. Ordinary conditions are defined as space available with only minor changes to support systems required, such as but not limited to, HVAC, cabling and the power plant(s). BellSouth will complete construction of all other Collocation Space ("extraordinary conditions") within one hundred twenty (120) calendar days of the receipt of a Bona Fide Firm Order. Examples of extraordinary conditions include but are not limited to, extended license or permitting intervals; major BellSouth equipment rearrangement or addition; power plant addition or upgrade; major mechanical addition or upgrade; major upgrade for ADA compliance; environmental hazard or hazardous materials abatement; and arrangements for which equipment shipping intervals are extraordinary in length. The Parties may mutually agree to renegotiate an alternative provisioning interval or BellSouth may seek a waiver from this interval from the Commission.
- 7.1.6 In Mississippi, excluding the time interval required to secure the appropriate government licenses and permits, BellSouth will complete construction for collocation arrangements under ordinary conditions as soon as possible and within a maximum of one hundred twenty (120) calendar days from receipt of a Bona Fide Firm Order or as agreed to by the Parties. Ordinary conditions are defined as space available with only minor changes to support systems required, such as but not limited to, HVAC, cabling and the power plant(s). Excluding the time interval required to secure the appropriate government licenses and permits, BellSouth will complete construction of all other Collocation Space ("extraordinary conditions") within one hundred eighty (180) calendar days of the receipt of a Bona Fide Firm Order. Examples of extraordinary conditions include but are not limited to, extended license or permitting intervals; major BellSouth equipment rearrangement or addition; power plant addition or

upgrade; major mechanical addition or upgrade; major upgrade for ADA compliance; environmental hazard or hazardous materials abatement; and arrangements for which equipment shipping intervals are extraordinary in length. The Parties may mutually agree to renegotiate an alternative provisioning interval or BellSouth may seek a waiver from this interval from the Commission.

- 7.1.7 In South Carolina, BellSouth will complete the construction and provisioning activities for cageless and caged collocation arrangements as soon as possible, but no later than ninety (90) calendar days from receipt of a bona fide firm order. The Parties may mutually agree to renegotiate an alternative provisioning interval or BellSouth may seek a waiver from this interval from the Commission.
- 7.2 Joint Planning. Joint planning between BellSouth and Heritage will commence within a maximum of twenty (20) calendar days from BellSouth's receipt of a Bona Fide Firm Order. BellSouth will provide the preliminary design of the Collocation Space and the equipment configuration requirements as reflected in the Bona Fide Application and affirmed in the Bona Fide Firm Order. The Collocation Space completion time period will be provided to Heritage during joint planning.
- 7.3 Permits. Each Party or its agents will diligently pursue filing for the permits required for the scope of work to be performed by that Party or its agents within ten (10) calendar days of the completion of finalized construction designs and specifications.
- 7.4 Acceptance Walk Through. Heritage will schedule and complete an acceptance walkthrough of each Collocation Space with BellSouth within fifteen (15) days of BellSouth's notifying Heritage that the collocation space is ready for occupancy. In the event that Heritage fails to complete an acceptance walkthrough within this fifteen (15) day interval, the Collocation Space shall be deemed accepted by Heritage. BellSouth will correct any deviations to Heritage's original or jointly amended requirements within seven (7) calendar days after the walk through, unless the Parties jointly agree upon a different time frame.
- 7.5 Use of BellSouth Certified Supplier. Heritage shall select a supplier which has been approved as a BellSouth Certified Supplier to perform all engineering and installation work. Heritage and Heritage's BellSouth Certified Supplier must follow and comply with all BellSouth requirements outlined in BellSouth's TR 73503, TR 73519, TR 73572, and TR 73564. In some cases, Heritage must select separate BellSouth Certified Suppliers for transmission equipment, switching equipment and power equipment. BellSouth shall provide Heritage with a list of BellSouth Certified Suppliers upon request. The BellSouth Certified Supplier(s) shall be responsible for installing Heritage's equipment and components, extending power cabling to the BellSouth power distribution frame, performing operational tests after installation is complete, and notifying BellSouth's equipment engineers and Heritage upon successful completion of installation, etc. The BellSouth Certified Supplier shall bill Heritage directly for all work performed for Heritage pursuant to this Attachment and BellSouth shall have no liability for nor responsibility to pay such charges imposed by the BellSouth Certified Supplier. BellSouth shall consider certifying Heritage or any

supplier proposed by Heritage. All work performed by or for Heritage shall conform to generally accepted industry guidelines and standards.

- 7.6 **Alarm and Monitoring.** BellSouth shall place environmental alarms in the Premises for the protection of BellSouth equipment and facilities. Heritage shall be responsible for placement, monitoring and removal of environmental and equipment alarms used to service Heritage's Collocation Space. Upon request, BellSouth will provide Heritage with applicable tariffed service(s) to facilitate remote monitoring of collocated equipment by Heritage. Both Parties shall use best efforts to notify the other of any verified environmental condition known to that Party.
- 7.7 **Virtual to Physical Collocation Relocation.** In the event physical collocation space was previously denied at a location due to technical reasons or space limitations, and physical collocation space has subsequently become available, Heritage may relocate its virtual collocation arrangements to physical collocation arrangements and pay the appropriate fees for physical collocation and for the rearrangement or reconfiguration of services terminated in the virtual collocation arrangement, as outlined in the appropriate BellSouth tariffs. In the event that BellSouth knows when additional space for physical collocation may become available at the location requested by Heritage, such information will be provided to Heritage in BellSouth's written denial of physical collocation. To the extent that (i) physical Collocation Space becomes available to Heritage within 180 calendar days of BellSouth's written denial of Heritage's request for physical collocation, (ii) BellSouth had knowledge that the space was going to become available, and (iii) Heritage was not informed in the written denial that physical Collocation Space would become available within such 180 calendar days, then Heritage may relocate its virtual collocation arrangement to a physical collocation arrangement and will receive a credit for any nonrecurring charges previously paid for such virtual collocation. Heritage must arrange with a BellSouth Certified Supplier for the relocation of equipment from its virtual Collocation Space to its physical Collocation Space and will bear the cost of such relocation.
- 7.8 **Cancellation.** If, at anytime prior to space acceptance, Heritage cancels its order for the Collocation Space(s) ("Cancellation"), BellSouth will bill the applicable non-recurring rate for any and all work processes for which work has begun. In Georgia, if Heritage cancels its order for Collocation Space at any time prior to space acceptance, BellSouth will bill Heritage for all costs incurred prior to the date of Cancellation and for any costs incurred as a direct result of the Cancellation, not to exceed the total amount that would have been due had the order not been cancelled.
- 7.9 **Licenses.** Heritage, at its own expense, will be solely responsible for obtaining from governmental authorities, and any other appropriate agency, entity, or person, all rights, privileges, and licenses necessary or required to operate as a provider of telecommunications services to the public or to occupy the Collocation Space.
- 7.10 **Environmental Compliance.** The Parties agree to utilize and adhere to the Environmental Hazard Guidelines identified as Exhibit A attached hereto.

7.11 The intervals as set forth above are as depicted in Exhibit B of this Attachment.

8. Rates and Charges

8.1 BellSouth shall assess an Application Fee via a service order which shall be issued at the time BellSouth responds that space is available pursuant to Section 2. Payment of said Application Fee will be due as dictated by Heritage's current billing cycle and is non-refundable.

8.2 Space Preparation

8.2.1 Recurring Charges. The recurring charges for space preparation begin on the Space Ready Date or the day Heritage occupies the collocation space, whichever occurs first.

8.2.2 Space preparation fees consist of a nonrecurring charge for Firm Order Processing and monthly recurring charges for Central Office Modifications, assessed per arrangement, per square foot, and Common Systems Modifications, assessed per arrangement, per square foot for cageless collocation and per cage for caged collocation. Heritage shall remit payment of the nonrecurring Firm Order Processing Fee coincident with submission of a Bona Fide Firm Order. The charges recover the costs associated with preparing the Collocation Space, which includes survey, engineering of the Collocation Space, design and modification costs for network, building and support systems. In the event Heritage opts for cageless space, the space preparation fees will be assessed based on the total floor space dedicated to Heritage as prescribed in this Section 8.

8.2.3 Space Preparation Fee (Florida). Space preparation fees include a nonrecurring charge for Firm Order Processing and monthly recurring charges for Central Office Modifications, assessed per arrangement, per square foot, and Common Systems Modifications, assessed per arrangement, per square foot for cageless and per cage for caged collocation. Heritage shall remit payment of the nonrecurring Firm Order Processing Fee coincident with submission of a Bona Fide Firm Order. The charges recover the costs associated with preparing the Collocation Space, which includes survey, engineering of the Collocation Space, design and modification costs for network, building and support systems. In the event Heritage opts for cageless space, space preparation fees will be assessed based on the total floor space dedicated to Heritage as prescribed in this Section 8.

8.2.4 Space Preparation Fee (Georgia). In Georgia, the Space Preparation Fee is a one-time fee, assessed per arrangement, per location. It recovers a portion of costs associated with preparing the Collocation Space, which includes survey, engineering of the Collocation Space, design and modification costs for network, power, building and support systems. This is a set fee of \$100 per square foot as established by the Georgia Public Service Commission Order in Docket No. 7061-U. In the event Heritage opts for non-enclosed space, the space preparation fee will be assessed based on the total floor space dedicated to Heritage as prescribed in this Section 8 and will be billed based upon Heritage's first billing cycle after Firm Order.

- 8.2.5 **Space Preparation Fee (North Carolina)**. In North Carolina, space preparation fees consist of monthly recurring charges for Central Office Modifications, assessed per arrangement, per square foot; Common Systems Modifications, assessed per arrangement, per square foot for cageless and per cage for caged collocation; and Power, assessed per the nominal -48V DC ampere requirements specified by Heritage on the Bona Fide Application. The charges recover the costs associated with preparing the Collocation Space, which includes survey, engineering of the Collocation Space, design and modification costs for network, building and support systems. In the event Heritage opts for cageless space, the space preparation fees will be assessed based on the total floor space dedicated to Heritage as described in this Section 8.
- 8.3 **Cable Installation**. Cable Installation Fee(s) are assessed per entrance cable placed.
- 8.4 **Floor Space**. The Floor Space Charge includes reasonable charges for lighting, HVAC, and other allocated expenses associated with maintenance of the Premises but does not recover any power-related costs incurred by BellSouth. When the Collocation Space is enclosed, Heritage shall pay floor space charges based upon the number of square feet so enclosed. When the Collocation Space is not enclosed, Heritage shall pay floor space charges based upon the following floor space calculation: [(depth of the equipment lineup in which the rack is placed) + (0.5 x maintenance aisle depth) + (0.5 x wiring aisle depth)] X (width of rack and spacers). For purposes of this calculation, the depth of the equipment lineup shall consider the footprint of equipment racks plus any equipment overhang. BellSouth will assign unenclosed Collocation Space in conventional equipment rack lineups where feasible. In the event Heritage's collocated equipment requires special cable racking, isolated grounding or other treatment which prevents placement within conventional equipment rack lineups, Heritage shall be required to request an amount of floor space sufficient to accommodate the total equipment arrangement. Floor space charges begin on the Space Ready Date, or on the date Heritage first occupies the Collocation Space, whichever is sooner.
- 8.5 **Power**. BellSouth shall make available -48 Volt (-48V) DC power for Heritage's Collocation Space at a BellSouth Power Board or BellSouth Battery Distribution Fuse Bay ("BDFB") at Heritage's option within the Premises.
- 8.5.1 Recurring charges for -48V DC power will be assessed per ampere per month based upon the BellSouth Certified Supplier engineered and installed power feed fused ampere capacity. Rates include redundant feeder fuse positions (A&B) and common cable rack to Heritage's equipment or space enclosure. Recurring power charges begin on the Space Ready Date, or on the date Heritage first occupies the Collocation Space, whichever is sooner. When obtaining power from a BDFB, fuses and power cables (A&B) must be engineered (sized), and installed by Heritage's BellSouth Certified Supplier. When obtaining power from a BellSouth power board, power cables (A&B) must be engineered (sized), and installed by Heritage's BellSouth Certified power Supplier. Heritage is responsible for contracting with a BellSouth Certified Supplier for power distribution feeder cable runs from a BellSouth BDFB or power board to Heritage's equipment. Determination of the BellSouth BDFB or

BellSouth power board as the power source will be made at BellSouth's sole, but reasonable, discretion. The BellSouth Certified Supplier contracted by Heritage must provide BellSouth a copy of the engineering power specification prior to the day on which Heritage's equipment becomes operational. BellSouth will provide the common power feeder cable support structure between the BellSouth BDFB or power board and Heritage's arrangement area. Heritage shall contract with a BellSouth Certified Supplier who will be responsible for the following: dedicated power cable support structure within Heritage's arrangement; power cable feeds; terminations of cable. Any terminations at a BellSouth power board must be performed by a BellSouth Certified power Supplier. Heritage shall comply with all applicable National Electric Code (NEC), BellSouth TR73503, Telcordia (BellCore) and ANSI Standards regarding power cabling.

- 8.5.2 If BellSouth has not previously invested in power plant capacity for collocation at a specific site, Heritage has the option to add its own dedicated power plant; provided, however, that such work shall be performed by a BellSouth Certified Supplier who shall comply with BellSouth's guidelines and specifications. Where the addition of Heritage's dedicated power plant results in construction of a new power plant room, upon termination of Heritage's right to occupy collocation space at such site, Heritage shall have the right to remove its equipment from the power plant room, but shall otherwise leave the room intact.
- 8.5.3 If Heritage elects to install its own DC Power Plant, BellSouth shall provide AC power to feed Heritage's DC Power Plant. Charges for AC power will be assessed per breaker ampere per month. Rates include the provision of commercial and standby AC power. When obtaining power from a BellSouth service panel, protection devices and power cables must be engineered (sized), and installed by Heritage's BellSouth Certified Supplier except that BellSouth shall engineer and install protection devices and power cables for Adjacent Collocation. Heritage's BellSouth Certified Supplier must also provide a copy of the engineering power specification prior to the equipment becoming operational. Charges for AC power shall be assessed pursuant to the rates specified in Exhibit D. AC power voltage and phase ratings shall be determined on a per location basis. At Heritage's option, Heritage may arrange for AC power in an Adjacent Collocation arrangement from a retail provider of electrical power.
- 8.6 Security Escort. A security escort will be required whenever Heritage or its approved agent desires access to the entrance manhole or must have access to the Premises after the one accompanied site visit allowed pursuant to Section 5 prior to completing BellSouth's Security Training requirements. Rates for a security escort are assessed according to the schedule appended hereto as Exhibit D beginning with the scheduled escort time. BellSouth will wait for one-half (1/2) hour after the scheduled time for such an escort and Heritage shall pay for such half-hour charges in the event Heritage fails to show up.
- 8.7 Cable Record charges. These charges apply for work required to build cable records in BellSouth systems. The VG/DSO per cable record charge is for a maximum of 3600 records. The Fiber cable record charge is for a maximum of 99 records.

8.8 **Rate "True-Up"**. The Parties agree that the prices reflected as interim herein shall be "true-up" (up or down) based on final prices either determined by further agreement or by an effective order, in a proceeding involving BellSouth before the regulatory authority for the state in which the services are being performed or any other body having jurisdiction over this Agreement (hereinafter "Commission"). Under the "true-up" process, the interim price for each service shall be multiplied by the volume of that service purchased to arrive at the total interim amount paid for that service ("Total Interim Price"). The final price for that service shall be multiplied by the volume purchased to arrive at the total final amount due ("Total Final Price"). The Total Interim Price shall be compared with the Total Final Price. If the Total Final Price is more than the Total Interim Price, Heritage shall pay the difference to BellSouth. If the Total Final Price is less than the Total Interim Price, BellSouth shall pay the difference to Heritage. Each Party shall keep its own records upon which a "true-up" can be based and any final payment from one Party to the other shall be in an amount agreed upon by the Parties based on such records. In the event of any disagreement as between the records or the Parties regarding the amount of such "true-up," the Parties agree that the Commission shall be called upon to resolve such differences.

8.9 **Other**. If no rate is identified in the contract, the rate for the specific service or function will be negotiated by the Parties upon request by either Party. Payment of all other charges under this Attachment shall be due thirty (30) calendar days after receipt of the bill (payment due date). Heritage will pay a late payment charge of the lessor of one and one half percent or the legal interest rate assessed monthly on any balance which remains unpaid after the payment due date.

9. **Insurance**

9.1 Heritage shall, at its sole cost and expense, procure, maintain, and keep in force insurance as specified in this Section 9 and underwritten by insurance companies licensed to do business in the states applicable under this Attachment and having a Best's Insurance Rating of A-.

9.2 Heritage shall maintain the following specific coverage:

9.2.1 **Commercial General Liability coverage in the amount of ten million dollars (\$10,000,000.00) or a combination of Commercial General Liability and Excess/Umbrella coverage totaling not less than ten million dollars (\$10,000,000.00).** BellSouth shall be named as an Additional Insured on the Commercial General Liability policy as specified herein.

9.2.2 **Statutory Workers Compensation coverage and Employers Liability coverage in the amount of one hundred thousand dollars (\$100,000.00) each accident, one hundred thousand dollars (\$100,000.00) each employee by disease, and five hundred thousand dollars (\$500,000.00) policy limit by disease.**

- 9.2.3 All Risk Property coverage on a full replacement cost basis insuring all of Heritage's real and personal property situated on or within BellSouth's Central Office location(s).
- 9.2.4 Heritage may elect to purchase business interruption and contingent business interruption insurance, having been advised that BellSouth assumes no liability for loss of profit or revenues should an interruption of service occur.
- 9.3 The limits set forth in Section 9.2 above may be increased by BellSouth from time to time during the term of this Attachment upon thirty (30) days notice to Heritage to at least such minimum limits as shall then be customary with respect to comparable occupancy of BellSouth structures.
- 9.4 All policies purchased by Heritage shall be deemed to be primary and not contributing to or in excess of any similar coverage purchased by BellSouth. All insurance must be in effect on or before the date equipment is delivered to BellSouth's Premises and shall remain in effect for the term of this Attachment or until all Heritage's property has been removed from BellSouth's Premises, whichever period is longer. If Heritage fails to maintain required coverage, BellSouth may pay the premiums thereon and seek reimbursement of same from Heritage.
- 9.5 Heritage shall submit certificates of insurance reflecting the coverage required pursuant to this Section a minimum of ten (10) business days prior to the commencement of any work in the Collocation Space. Failure to meet this interval may result in construction and equipment installation delays. Heritage shall arrange for BellSouth to receive thirty (30) business days' advance notice of cancellation from Heritage's insurance company. Heritage shall forward a certificate of insurance and notice of cancellation/non-renewal to BellSouth at the following address:
- BellSouth Telecommunications, Inc.
Attn.: Risk Management Coordinator
17H53 BellSouth Center
675 W. Peachtree Street
Atlanta, Georgia 30375
- 9.6 Heritage must conform to recommendations made by BellSouth's fire insurance company to the extent BellSouth has agreed to, or shall hereafter agree to, such recommendations.
- 9.7 Self-Insurance. If Heritage's net worth exceeds five hundred million dollars (\$500,000,000), Heritage may elect to request self-insurance status in lieu of obtaining any of the insurance required in Sections 9.2.1 and 9.2.2. Heritage shall provide audited financial statements to BellSouth thirty (30) days prior to the commencement of any work in the Collocation Space. BellSouth shall then review such audited financial statements and respond in writing to Heritage in the event that self-insurance status is not granted to Heritage. If BellSouth approves Heritage for self-insurance, Heritage shall annually furnish to BellSouth, and keep current, evidence of such net worth that is attested to by one of Heritage's corporate officers. The ability to self-

insure shall continue so long as the Heritage meets all of the requirements of this Section. If the Heritage subsequently no longer satisfies this Section, Heritage is required to purchase insurance as indicated by Sections 9.2.1 and 9.2.2.

- 9.8 The net worth requirements set forth in Section 9.7 may be increased by BellSouth from time to time during the term of this Attachment upon thirty (30) days' notice to Heritage to at least such minimum limits as shall then be customary with respect to comparable occupancy of BellSouth structures.
- 9.9 Failure to comply with the provisions of this Section will be deemed a material breach of this Attachment.

10. Mechanics Liens

- 10.1 If any mechanics lien or other liens shall be filed against property of either Party (BellSouth or Heritage), or any improvement thereon by reason of or arising out of any labor or materials furnished or alleged to have been furnished or to be furnished to or for the other Party or by reason of any changes, or additions to said property made at the request or under the direction of the other Party, the other Party directing or requesting those changes shall, within thirty (30) business days after receipt of written notice from the Party against whose property said lien has been filed, either pay such lien or cause the same to be bonded off the affected property in the manner provided by law. The Party causing said lien to be placed against the property of the other shall also defend, at its sole cost and expense, on behalf of the other, any action, suit or proceeding which may be brought for the enforcement of such liens and shall pay any damage and discharge any judgment entered thereon.

11. Inspections

- 11.1 BellSouth may conduct an inspection of Heritage's equipment and facilities in the Collocation Space(s) prior to the activation of facilities between Heritage's equipment and equipment of BellSouth. BellSouth may conduct an inspection if Heritage adds equipment and may otherwise conduct routine inspections at reasonable intervals mutually agreed upon by the Parties. BellSouth shall provide Heritage with a minimum of forty-eight (48) hours or two (2) business days, whichever is greater, advance notice of all such inspections. All costs of such inspection shall be borne by BellSouth.

12. Security and Safety Requirements

- 12.1 Heritage will be required, at its own expense, to conduct a statewide investigation of criminal history records for each Heritage employee being considered for work on the BellSouth Premises, for the states/counties where the Heritage employee has worked and lived for the past five years. Where state law does not permit statewide collection or reporting, an investigation of the applicable counties is acceptable. Heritage shall

not be required to perform this investigation if an affiliated company of Heritage has performed an investigation of the Heritage employee seeking access, if such investigation meets the criteria set forth above. This requirement will not apply if Heritage has performed a pre-employment statewide investigation of criminal history records of the Heritage employee for the states/counties where the Heritage employee has worked and lived for the past five years or, where state law does not permit a statewide investigation, an investigation of the applicable counties.

- 12.2 Heritage shall provide its employees and agents with picture identification which must be worn and visible at all times while in the Collocation Space or other areas in or around the Premises. The photo Identification card shall bear, at a minimum, the employee's name and photo, and the Heritage name. BellSouth reserves the right to remove from its premises any employee of Heritage not possessing identification issued by Heritage or who have violated any of BellSouth's policies as outlined in the CLEC Security Training documents. Heritage shall hold BellSouth harmless for any damages resulting from such removal of its personnel from BellSouth premises. Heritage shall be solely responsible for ensuring that any Guest of Heritage is in compliance with all subsections of this Section 12.
- 12.3 Heritage will be required to administer to their personnel assigned to the BellSouth Premises security training either provided by BellSouth, or meeting criteria defined by BellSouth.
- 12.4 Heritage shall not assign to the BellSouth Premises any personnel with records of felony criminal convictions. Heritage shall not assign to the BellSouth Premises any personnel with records of misdemeanor convictions, except for misdemeanor traffic violations, without advising BellSouth of the nature and gravity of the offense(s). BellSouth reserves the right to refuse building access to any Heritage personnel who have been identified to have misdemeanor criminal convictions. Notwithstanding the foregoing, in the event that Heritage chooses not to advise BellSouth of the nature and gravity of any misdemeanor conviction, Heritage may, in the alternative, certify to BellSouth that it shall not assign to the BellSouth Premises any personnel with records of misdemeanor convictions (other than misdemeanor traffic violations).
- 12.4.1 Heritage shall not knowingly assign to the BellSouth Premises any individual who was a former employee of BellSouth and whose employment with BellSouth was terminated for a criminal offense whether or not BellSouth sought prosecution of the individual for the criminal offense.
- 12.4.2 Heritage shall not knowingly assign to the BellSouth Premises any individual who was a former contractor of BellSouth and whose access to a BellSouth Premises was revoked due to commission of a criminal offense whether or not BellSouth sought prosecution of the individual for the criminal offense.
- 12.5 For each Heritage employee requiring access to a BellSouth Premises pursuant to this Attachment, Heritage shall furnish BellSouth, prior to an employee gaining such access, a certification that the aforementioned background check and security training

were completed. The certification will contain a statement that no felony convictions were found and certifying that the security training was completed by the employee. If the employee's criminal history includes misdemeanor convictions, Heritage will disclose the nature of the convictions to BellSouth at that time. In the alternative, Heritage may certify to BellSouth that it shall not assign to the BellSouth Premises any personnel with records of misdemeanor convictions other than misdemeanor traffic violations.

- 12.6 At BellSouth's request, Heritage shall promptly remove from BellSouth's Premises any employee of Heritage BellSouth does not wish to grant access to its premises 1) pursuant to any investigation conducted by BellSouth or 2) prior to the initiation of an investigation if an employee of Heritage is found interfering with the property or personnel of BellSouth or another CLEC, provided that an investigation shall promptly be commenced by BellSouth.
- 12.7 Notification to BellSouth. BellSouth reserves the right to interview Heritage's employees, agents, or contractors in the event of wrongdoing in or around BellSouth's property or involving BellSouth's or another CLEC's property or personnel, provided that BellSouth shall provide reasonable notice to Heritage's Security contact of such interview. Heritage and its contractors shall reasonably cooperate with BellSouth's investigation into allegations of wrongdoing or criminal conduct committed by, witnessed by, or involving Heritage's employees, agents, or contractors. Additionally, BellSouth reserves the right to bill Heritage for all reasonable costs associated with investigations involving its employees, agents, or contractors if it is established and mutually agreed in good faith that Heritage's employees, agents, or contractors are responsible for the alleged act. BellSouth shall bill Heritage for BellSouth property which is stolen or damaged where an investigation determines the culpability of Heritage's employees, agents, or contractors and where Heritage agrees, in good faith, with the results of such investigation. Heritage shall notify BellSouth in writing immediately in the event that Heritage discovers one of its employees already working on the BellSouth premises is a possible security risk. Upon request of the other Party, the Party who is the employer shall discipline consistent with its employment practices, up to and including removal from BellSouth Premises, any employee found to have violated the security and safety requirements of this section. Heritage shall hold BellSouth harmless for any damages resulting from such removal of its personnel from BellSouth premises.
- 12.8 Use of Supplies. Unauthorized use of telecommunications equipment or supplies by either Party, whether or not used routinely to provide telephone service (e.g. plug-in cards,) will be strictly prohibited and handled appropriately. Costs associated with such unauthorized use may be charged to the offending Party, as may be all associated investigative costs.
- 12.9 Use of Official Lines. Except for non-toll calls necessary in the performance of their work, neither Party shall use the telephones of the other Party on the BellSouth Premises. Charges for unauthorized telephone calls may be charged to the offending Party, as may be all associated investigative costs.

12.10 Accountability. Full compliance with the Security requirements of this section shall in no way limit the accountability of either Party to the other for the improper actions of its employees.

13. Destruction of Collocation Space

13.1 In the event a Collocation Space is wholly or partially damaged by fire, windstorm, tornado, flood or by similar causes to such an extent as to be rendered wholly unsuitable for Heritage's permitted use hereunder, then either Party may elect within ten (10) business days after such damage, to terminate occupancy of the damaged Collocation Space, and if either Party shall so elect, by giving the other written notice of termination, both Parties shall stand released of and from further liability under the terms hereof. If the Collocation Space shall suffer only minor damage and shall not be rendered wholly unsuitable for Heritage's permitted use, or is damaged and the option to terminate is not exercised by either Party, BellSouth covenants and agrees to proceed promptly without expense to Heritage, except for improvements not the property of BellSouth, to repair the damage. BellSouth shall have a reasonable time within which to rebuild or make any repairs, and such rebuilding and repairing shall be subject to delays caused by storms, shortages of labor and materials, government regulations, strikes, walkouts, and causes beyond the control of BellSouth, which causes shall not be construed as limiting factors, but as exemplary only. Heritage may, at its own expense, accelerate the rebuild of its collocated space and equipment provided however that a BellSouth Certified Contractor is used and the necessary space preparation has been completed. Rebuild of equipment must be performed by a BellSouth Certified Vendor. If Heritage's acceleration of the project increases the cost of the project, then those additional charges will be incurred by Heritage. Where allowed and where practical, Heritage may erect a temporary facility while BellSouth rebuilds or makes repairs. In all cases where the Collocation Space shall be rebuilt or repaired, Heritage shall be entitled to an equitable abatement of rent and other charges, depending upon the unsuitability of the Collocation Space for Heritage's permitted use, until such Collocation Space is fully repaired and restored and Heritage's equipment installed therein (but in no event later than thirty (30) business days after the Collocation Space is fully repaired and restored). Where Heritage has placed an Adjacent Arrangement pursuant to Section 3, Heritage shall have the sole responsibility to repair or replace said Adjacent Arrangement provided herein. Pursuant to this section, BellSouth will restore the associated services to the Adjacent Arrangement.

14. Eminent Domain

14.1 If the whole of a Collocation Space or Adjacent Arrangement shall be taken by any public authority under the power of eminent domain, then this Attachment shall terminate with respect to such Collocation Space or Adjacent Arrangement as of the day possession shall be taken by such public authority and rent and other charges for the Collocation Space or Adjacent Arrangement shall be paid up to that day with

proportionate refund by BellSouth of such rent and charges as may have been paid in advance for a period subsequent to the date of the taking. If any part of the Collocation Space or Adjacent Arrangement shall be taken under eminent domain, BellSouth and Heritage shall each have the right to terminate this Attachment with respect to such Collocation Space or Adjacent Arrangement and declare the same null and void, by written notice of such intention to the other Party within ten (10) business days after such taking.

15. Nonexclusivity

15.1 Heritage understands that this Attachment is not exclusive and that BellSouth may enter into similar agreements with other Parties. Assignment of space pursuant to all such agreements shall be determined by space availability and made on a first come, first served basis.

ENVIRONMENTAL AND SAFETY PRINCIPLES

The following principles provide basic guidance on environmental and safety issues when applying for and establishing Physical Collocation arrangements.

1. GENERAL PRINCIPLES

- 1.1 **Compliance with Applicable Law.** BellSouth and Heritage agree to comply with applicable federal, state, and local environmental and safety laws and regulations including U.S. Environmental Protection Agency (USEPA) regulations issued under the Clean Air Act (CAA), Clean Water Act (CWA), Resource Conservation and Recovery Act (RCRA), Comprehensive Environmental Response, Compensation and Liability Act (CERCLA), Superfund Amendments and Reauthorization Act (SARA), the Toxic Substances Control Act (TSCA), and OSHA regulations issued under the Occupational Safety and Health Act of 1970, as amended and NFPA and National Electrical Codes (NEC) and the NESC ("Applicable Laws"). Each Party shall notify the other if compliance inspections are conducted by regulatory agencies and/or citations are issued that relate to any aspect of this Attachment.
- 1.2 **Notice.** BellSouth and Heritage shall provide notice to the other, including Material Safety Data Sheets (MSDSs), of known and recognized physical hazards or Hazardous Chemicals existing on site or brought on site. Each Party is required to provide specific notice for known potential Imminent Danger conditions. Heritage should contact 1-800-743-6737 for BellSouth MSDS sheets.
- 1.3 **Practices/Procedures.** BellSouth may make available additional environmental control procedures for Heritage to follow when working at a BellSouth Premises (See Section 2, below). These practices/procedures will represent the regular work practices required to be followed by the employees and contractors of BellSouth for environmental protection. Heritage will require its contractors, agents and others accessing the BellSouth Premises to comply with these practices. Section 2 lists the Environmental categories where BST practices should be followed by Heritage when operating in the BellSouth Premises.
- 1.4 **Environmental and Safety Inspections.** BellSouth reserves the right to inspect the Heritage space with proper notification. BellSouth reserves the right to stop any Heritage work operation that imposes Imminent Danger to the environment, employees or other persons in the area or Facility.
- 1.5 **Hazardous Materials Brought On Site.** Any hazardous materials brought into, used, stored or abandoned at the BellSouth Premises by Heritage are owned by Heritage. Heritage will indemnify BellSouth for claims, lawsuits or damages to persons or property caused by these materials. Without prior written BellSouth approval, no

substantial new safety or environmental hazards can be created by Heritage or different hazardous materials used by Heritage at BellSouth Facility. Heritage must demonstrate adequate emergency response capabilities for its materials used or remaining at the BellSouth Facility.

- 1.6 Spills and Releases. When contamination is discovered at a BellSouth Premises, the Party discovering the condition must notify BellSouth. All Spills or Releases of regulated materials will immediately be reported by Heritage to BellSouth.
- 1.7 Coordinated Environmental Plans and Permits. BellSouth and Heritage will coordinate plans, permits or information required to be submitted to government agencies, such as emergency response plans, spill prevention control and countermeasures (SPCC) plans and community reporting. If fees are associated with filing, BellSouth and Heritage will develop a cost sharing procedure. If BellSouth's permit or EPA identification number must be used, Heritage must comply with all of BellSouth's permit conditions and environmental processes, including environmental "best management practices (BMP)" (see Section 2, below) and/or selection of BST disposition vendors and disposal sites.
- 1.8 Environmental and Safety Indemnification. BellSouth and Heritage shall indemnify, defend and hold harmless the other Party from and against any claims (including, without limitation, third-party claims for personal injury or death or real or personal property damage), judgments, damages, (including direct and indirect damages, and punitive damages), penalties, fines, forfeitures, costs, liabilities, interest and losses arising in connection with the violation or alleged violation of any Applicable Law or contractual obligation or the presence or alleged presence of contamination arising out of the acts or omissions of the indemnifying Party, its agents, contractors, or employees concerning its operations at the Facility.

2. CATEGORIES FOR CONSIDERATION OF ENVIRONMENTAL ISSUES

- 2.1 When performing functions that fall under the following Environmental categories on BellSouth's Premises, Heritage agrees to comply with the applicable sections of the current issue of BellSouth's Environmental and Safety Methods and Procedures (M&Ps), incorporated herein by this reference. Heritage further agrees to cooperate with BellSouth to ensure that Heritage's employees, agents, and/or subcontractors are knowledgeable of and satisfy those provisions of BellSouth's Environmental M&Ps which apply to the specific Environmental function being performed by Heritage, its employees, agents and/or subcontractors.
- 2.2 The most current version of reference documentation must be requested from BellSouth.

ENVIRONMENTAL CATEGORIES	ENVIRONMENTAL ISSUES	ADDRESSED BY THE FOLLOWING DOCUMENTATION
Disposal of hazardous material or other regulated material (e.g., batteries, fluorescent tubes, solvents & cleaning materials)	Compliance with all applicable local, state, & federal laws and regulations Pollution liability insurance EVET approval of contractor	Std T&C 450 Fact Sheet Series 17000 Std T&C 660-3 Approved Environmental Vendor List (Contact E/S Management)
Emergency response	Hazmat/waste release/spill firesafety emergency	Fact Sheet Series 1700 Building Emergency Operations Plan (EOP) (specific to and located on Premises)
Contract labor/outsourcing for services with environmental implications to be performed on BellSouth Premises (e.g., disposition of hazardous material/waste; maintenance of storage tanks)	Compliance with all applicable local, state, & federal laws and regulations Performance of services in accordance with BST's environmental M&Ps Insurance	Std T&C 450 Std T&C 450-B (Contact E/S for copy of appropriate E/S M&Ps.) Std T&C 660
Transportation of hazardous material	Compliance with all applicable local, state, & federal laws and regulations Pollution liability insurance EVET approval of contractor	Std T&C 450 Fact Sheet Series 17000 Std T&C 660-3 Approved Environmental Vendor List (Contact E/S Management)
Maintenance/operations work which may produce a waste Other maintenance work	Compliance with all application local, state, & federal laws and regulations Protection of BST employees and equipment	Std T&C 450 29CFR 1910.147 (OSHA Standard) 29CFR 1910 Subpart O (OSHA Standard)

Janitorial services	All waste removal and disposal must conform to all applicable federal, state and local regulations All Hazardous Material and Waste Asbestos notification and protection of employees and equipment	P&SM Manager - Procurement Fact Sheet Series 17000 GU-BTEN-001BT, Chapter 3 BSP 010-170-001BS (Hazcom)
Manhole cleaning	Compliance with all applicable local, state, & federal laws and regulations Pollution liability insurance EVET approval of contractor	Std T&C 450 Fact Sheet 14050 BSP 620-145-011PR Issue A, August 1996 Std T&C 660-3 Approved Environmental Vendor List (Contact E/S Management)
Removing or disturbing building materials that may contain asbestos	Asbestos work practices	GU-BTEN-001BT, Chapter 3

3. DEFINITIONS

Generator. Under RCRA, the person whose act produces a Hazardous Waste, as defined in 40 CFR 261, or whose act first causes a Hazardous Waste to become subject to regulation. The Generator is legally responsible for the proper management and disposal of Hazardous Wastes in accordance with regulations.

Hazardous Chemical. As defined in the U.S. Occupational Safety and Health (OSHA) hazard communication standard (29 CFR 1910.1200), any chemical which is a health hazard or physical hazard.

Hazardous Waste. As defined in section 1004 of RCRA.

Imminent Danger. Any conditions or practices at a facility which are such that a danger exists which could reasonably be expected to cause immediate death or serious harm to people or immediate significant damage to the environment or natural resources.

Spill or Release. As defined in Section 101 of CERCLA.

4. ACRONYMS

E/S – Environmental/Safety

EVET - Environmental Vendor Evaluation Team

DEC/LDEC - Department Environmental Coordinator/Local Department Environmental Coordinator

GU-BTEN-001BT - BellSouth Environmental Methods and Procedures

NESC - National Electrical Safety Codes

P&SM - Property & Services Management

Std. T&C - Standard Terms & Conditions

Interval Matrix

State	Type	Space Availability/Bona Fide Firm Order	Application Response/Price Quote	Construction and Provisioning	
				Ordinary	Extraordinary
Alabama ¹	Caged	10 Calendar Days	23 Business Days	76 Bus.	91 Bus
	Cageless	10 Calendar Days	23 Business Days	60 Cal	90 Cal
Florida	Caged	15 Calendar Days	15 Calendar Days*	90 Cal	NA
	Cageless	Same	Same	90 Cal	NA
Georgia	Caged	10 Calendar Days	30 Calendar Days	90 Cal	NA Cal
	Cageless	10 Calendar Days	30 Calendar Days	60 Cal	90 Cal
Kentucky ¹	Caged	10 Calendar Days	23 Business Days	76 Bus.	91 Bus
	Cageless	10 Calendar Days	23 Business Days	76 Bus.	91 Bus
Louisiana	Caged	10 Calendar Days*	30 Calendar Days*	90 Cal	120 Cal
	Cageless	10 Calendar Days*	30 Calendar Days*	90 Cal	120 Cal
Mississippi	Caged	10 Business Days	30 Business Days*	120 Cal	180Cal
	Cageless	10 Business Days	30 Business Days*	120Cal	180 Cal
North Carolina ¹	Caged	10 Calendar Days	23 Business Days	76 Bus.	91 Bus
	Cageless	10 Calendar Days	23 Business Days	76 Bus.	91 Bus
South Carolina	Caged	10 Calendar Days	30 Calendar Days*	90 Cal	NA Cal
	Cageless	10 Calendar Days	30 Calendar Days*	90 Cal	NA Cal
Tennessee ¹	Caged	10 Calendar Days	23 Business Days	76 Bus.	91 Bus
	Cageless	10 Calendar Days	23 Business Days	76 Bus.	91 Bus

* Extended intervals shall apply when multiple applications are submitted.

Note 1: The intervals were set by the FCC's Order in Docket No. 98-147 released February 20, 2001.

The construction and provisioning intervals, as listed for these states, will apply if a forecast is submitted three (3) months prior to the application date. Extended intervals shall apply if the forecast is not received three (3) months in advance.

THREE MONTH CLEC FORECAST

CLEC NAME _____

DATE _____

[REDACTED]											

*Standard bays are defined as racks, bays or cabinets, including equipment and cable, with measurements equal to or less than the following: Width - 26", Depth - 25". The standard height for all collocated equipment bays in BellSouth is 7'0".

** Any forecast for non-standard cageless bays must include an attachment describing the quantity and width and depth measurements.

Notes: Forecast information will be used for no other purpose than collocation planning.
Forecast with application dates greater than 3 months from the date of submission will not guarantee the reservation of space in the office requested.

Remote Site Physical Collocation

BELLSOUTH
REMOTE SITE PHYSICAL COLLOCATION

1. Scope of Attachment

- 1.1 Scope of Attachment. The rates, terms, and conditions contained within this Attachment shall only apply when Heritage is occupying the Remote Collocation Space as a sole occupant or as a Host within a Remote Site Location.
- 1.2 Right to occupy. BellSouth shall offer to Heritage Remote Site Collocation on rates, terms, and conditions that are just, reasonable, non-discriminatory and consistent with the rules of the Federal Communications Commission ("FCC"). Subject to the rates, terms, and conditions of this Attachment, BellSouth hereby grants to Heritage a right to occupy that certain area designated by BellSouth within a BellSouth Remote Site Location, of a size which is specified by Heritage and agreed to by BellSouth (hereinafter "Remote Collocation Space"). BellSouth Remote Site Locations include cabinets, huts, and controlled environmental vaults owned or leased by BellSouth that house BellSouth Network Facilities. To the extent this Attachment does not include all the necessary rates, terms and conditions for BellSouth remote locations other than cabinets, huts and controlled environmental vaults, the Parties will negotiate said rates, terms, and conditions at the request for collocation at BellSouth remote locations other than those specified above.
- 1.2.1 In all states other than Florida, the number of racks/bays specified by Heritage may contemplate a request for space sufficient to accommodate Heritage's growth within a two year period.
- 1.2.2 In the state of Florida, the number of racks/bays specified by Heritage may contemplate a request for space sufficient to accommodate Heritage's growth within an eighteen (18) month period.
- 1.2.3 Neither BellSouth nor any of BellSouth's affiliates may reserve space for future use on more preferential terms than those set forth above.
- 1.3 Third Party Property. If the Premises, or the property on which it is located, is leased by BellSouth from a Third Party or otherwise controlled by a Third Party, special considerations and intervals may apply in addition to the terms and conditions of this Agreement. Additionally, where BellSouth notifies Heritage that BellSouth's agreement with a Third Party does not grant BellSouth the ability to provide access and use rights to others, upon Heritage's request, BellSouth will use its best efforts to obtain the owner's consent and to otherwise secure such rights for Heritage. Heritage

agrees to reimburse BellSouth for the reasonable and demonstrable costs incurred by BellSouth in obtaining such rights for Heritage. In cases where a Third Party agreement does not grant BellSouth the right to provide access and use rights to others as contemplated by this Agreement and BellSouth, despite its best efforts, is unable to secure such access and use rights for Heritage as above, Heritage shall be responsible for obtaining such permission to access and use such property. BellSouth shall cooperate with Heritage in obtaining such permission.

- 1.4 **Space Reclamation.** In the event of space exhaust within a Remote Site Location, BellSouth may include in its documentation for the Petition for Waiver filing any vacant space in the Remote Site Location. Heritage will be responsible for any justification of vacant space within its Remote Collocation Space, if such justification is required by the appropriate state commission.
- 1.5 **Use of Space.** Heritage shall use the Remote Collocation Space for the purposes of installing, maintaining and operating Heritage's equipment (to include testing and monitoring equipment) necessary, for interconnection with BellSouth services and facilities, including access to unbundled network elements, for the provision of telecommunications services. The Remote Collocation Space may be used for no other purposes except as specifically described herein or authorized in writing by BellSouth.
- 1.6 **Rates and charges.** Heritage agrees to pay the rates and charges identified in Exhibit D attached hereto.
- 1.7 **Due Dates.** In all states except Georgia, if any due date contained in this Attachment falls on a weekend or holiday, then the due date will be the next business day thereafter.
2. **Space Availability Report**
- 2.1 **Reporting.** Upon request from Heritage, BellSouth will provide a written report ("Space Availability Report") specifying the amount of Remote Collocation Space available at the Remote Site Location requested, the number of collocators present at the Remote Site Location, any modifications in the use of the space since the last report on the Remote Site Location requested and the measures BellSouth is taking to make additional space available for collocation arrangements.
- 2.1.1 The request from Heritage for a Space Availability Report must be written and must include the Common Language Location Identification ("CLLI") code for both the Remote Site Location and the serving central office. Such information regarding the CLLI code for the serving central offices located in the National Exchange Carriers Association (NECA) Tariff FCC No. 4. If Heritage is unable to obtain the CLLI code,

from for example a site visit to the remote site, Heritage may request the CLLI code from BellSouth. To obtain a CLLI code for a remote site directly from BellSouth, Heritage should submit to BellSouth a Remote Site Interconnection Request for Remote Site CLLI Code prior to submitting its request for a Space Availability Report. Heritage should complete all the requested information and submit the Request with the applicable fee to BellSouth.

- 2.1.2 BellSouth will respond to a request for a Space Availability Report for a particular Remote Site Location within ten (10) calendar days of receipt of such request. This interval excludes national holidays. BellSouth will make best efforts to respond in ten (10) calendar days to such a request when the request includes from two (2) to five (5) Remote Site Locations within the same state. The response time for requests of more than five (5) Remote Site Locations shall be negotiated between the Parties. If BellSouth cannot meet the ten calendar day response time, BellSouth shall notify Heritage and inform Heritage of the time frame under which it can respond. In Mississippi, the above intervals shall be in business days.

3. Collocation Options

- 3.1 Compliance. The parties agree to comply with all applicable federal, state, county, local and administrative laws, orders, rules, ordinances, regulations, and codes in the performance of their obligations hereunder.
- 3.2 Cageless. BellSouth shall allow Heritage to collocate Heritage's equipment and facilities without requiring the construction of a cage or similar structure. BellSouth shall allow Heritage to have direct access to its equipment and facilities. BellSouth shall make cageless collocation available in single rack/bay increments. For equipment requiring special technical considerations, Heritage must provide the equipment layout, including spatial dimensions for such equipment pursuant to generic requirements contained in BellCore (Telcordia) GR-63-Core and shall be responsible for constructing all special technical requirements associated with such equipment pursuant to Section 6, following. Subject to space availability and technical feasibility, at Heritage's option, Heritage may enclose its equipment.
- 3.3 Shared (Subleased) Collocation. Heritage may allow other telecommunications carriers to share Heritage's Remote Collocation Space pursuant to terms and conditions agreed to by Heritage ("Host") and other telecommunications carriers ("Guests") and pursuant to this section, except where the BellSouth Remote Site Location is located within a leased space and BellSouth is prohibited by said lease from offering such an option or is located on property for which BellSouth holds an easement and such easement does not permit such an option. Heritage shall notify BellSouth in writing upon execution of any agreement between the Host and its Guest within ten (10) calendar days (in Mississippi, 10 business days) of its execution and prior to any Firm Order. Further, such notice shall include the name of the Guest(s)

and the term of the agreement, and shall contain a certification by Heritage that said agreement imposes upon the Guest(s) the same terms and conditions for Remote Collocation Space as set forth in this Attachment between BellSouth and Heritage.

- 3.3.1 Heritage shall be the sole interface and responsible Party to BellSouth for assessment of rates and charges contained within this Attachment; and for the purposes of ensuring that the safety and security requirements of this Attachment are fully complied with by the Guest, its employees and agents. BellSouth shall provide Heritage with a proration of the costs of the collocation space based on the number of collocators and the space used by each. In all states other than Florida, and in addition to the foregoing, Heritage shall be the responsible party to BellSouth for the purpose of submitting Applications for initial and additional equipment placement of Guest. In the event the Host and Guest jointly submit an Application, only one Application Fee will be assessed. A separate Guest Application shall require the assessment of an Application Fee, as set forth in Exhibit D. Notwithstanding the foregoing, Guest may arrange directly with BellSouth for the provision of the interconnecting facilities between BellSouth and Guest and for the provision of the services and access to unbundled network elements.
- 3.3.2 Heritage shall indemnify and hold harmless BellSouth from any and all claims, actions, causes of action, of whatever kind or nature arising out of the presence of Heritage's Guests in the Remote Collocation Space except to the extent caused by BellSouth's sole negligence, gross negligence, or willful misconduct.
- 3.4 Adjacent Collocation. Subject to technical feasibility and space availability, BellSouth will provide approval for adjacent Remote Site collocation arrangements ("Remote Site Adjacent Arrangement") where space within the Remote Site Location is legitimately exhausted, where the Remote Site Adjacent Arrangement does not interfere with access to existing or planned structures or facilities on the Remote Site Location property. The Remote Site Adjacent Arrangement shall be constructed or procured by Heritage and in conformance with BellSouth's design and construction specifications. Further, Heritage shall construct, procure, maintain and operate said Remote Site Adjacent Arrangement(s) pursuant to all of the terms and conditions set forth in this Attachment. Rates shall be negotiated at the time of the request for the Remote Site Adjacent Arrangement.
- 3.4.1 Should Heritage elect such an option, Heritage must arrange with a BellSouth Certified Contractor to construct a Remote Site Adjacent Arrangement structure in accordance with BellSouth's guidelines and specifications. BellSouth will provide guidelines and specifications upon request. Where local building codes require enclosure specifications more stringent than BellSouth's standard specification, Heritage and Heritage's BellSouth Certified Contractor must comply with local building code requirements. Heritage's BellSouth Certified Contractor shall be responsible for filing and receiving any and all necessary zoning, permits and/or licenses for such construction. Heritage's BellSouth Certified Contractor shall bill

Heritage directly for all work performed for Heritage pursuant to this Attachment and BellSouth shall have no liability for nor responsibility to pay such charges imposed by the BellSouth Certified Contractor. Heritage must provide the local BellSouth Remote Site Location contact with two cards, keys or other access device used to enter the locked enclosure. Except in cases of emergency, BellSouth shall not access Heritage's locked enclosure prior to notifying Heritage.

- 3.4.2 BellSouth maintains the right to review Heritage's plans and specifications prior to construction of a Remote Site Adjacent Arrangement(s). BellSouth shall complete its review within fifteen (15) calendar days. BellSouth may inspect the Remote Site Adjacent Arrangement(s) following construction and prior to the Commencement Date, as defined in Section 4 following, to ensure the design and construction comply with BellSouth's guidelines and specifications. BellSouth may require Heritage, at Heritage's sole cost, to correct any deviations from BellSouth's guidelines and specifications found during such inspection(s), up to and including removal of the Remote Site Adjacent Arrangement, within seven (7) calendar days of BellSouth's inspection, unless the Parties mutually agree to an alternative time frame.
- 3.4.3 Heritage shall provide a concrete pad, the structure housing the arrangement, heating/ventilation/air conditioning ("HVAC"), lighting, and all facilities that connect the structure (i.e. racking, conduits, etc.) to the BellSouth point of demarcation. At Heritage's option, and where the local authority having jurisdiction permits, BellSouth shall provide an AC power source and access to physical collocation services and facilities subject to the same nondiscriminatory requirements as applicable to any other physical collocation arrangement. Heritage's BellSouth Certified Contractor shall be responsible, at Heritage's expense, for filing and receiving any and all necessary zoning, permits and/or licenses for such arrangement.
- 3.4.4 BellSouth shall allow Shared (Subleased) Collocation within a Remote Site Adjacent Arrangement pursuant to the terms and conditions set forth herein.

4 Occupancy

- 4.1 **Occupancy.** BellSouth will notify Heritage in writing that the Remote Collocation Space is ready for occupancy. Heritage must notify BellSouth in writing that collocation equipment installation is complete. BellSouth may, at its option, not accept orders for interconnected service until receipt of such notice.
- 4.2 **Termination of Occupancy.** In addition to any other provisions addressing termination of occupancy in this Agreement, Heritage may terminate occupancy in a particular Remote Site Location by submitting a Subsequent Application requesting termination of occupancy. A Subsequent Application Fee will not apply for termination of occupancy.

- 4.2.1 Upon termination of occupancy, Heritage at its expense shall remove its equipment and other property from the Remote Collocation Space. Heritage shall have thirty (30) calendar days from the termination date to complete such removal, including the removal of all equipment and facilities of Heritage's Guests, unless Heritage's Guest has assumed responsibility for the collocation space housing the Guest's equipment and executed the documentation required by BellSouth prior to such removal date; provided, however, that Heritage shall continue payment of monthly fees to BellSouth until such date as Heritage, and if applicable Heritage's Guest, has fully vacated the Remote Collocation Space. Should Heritage or Heritage's Guest fail to vacate the Remote Collocation Space within thirty (30) calendar days from the termination date, BellSouth shall have the right to remove the equipment and other property of Heritage or Heritage's Guest at Heritage's expense and with no liability for damage or injury to Heritage or Heritage's Guest's property unless caused by the gross negligence or intentional misconduct of BellSouth. Upon termination of occupancy with respect to a Remote Collocation Space, Heritage shall surrender such Remote Collocation Space to BellSouth in the same condition as when first occupied by the Heritage except for ordinary wear and tear unless otherwise agreed to by the Parties. Heritage shall be responsible for the cost of removing any enclosure, together with all support structures (e.g., racking, conduits), of a Remote Site Adjacent-Arrangement at the termination of occupancy and restoring the grounds to their original condition.

5 Use of Remote Collocation Space

- 5.1 Equipment Type. BellSouth permits the collocation of any type of equipment necessary for interconnection to BellSouth's network or for access to unbundled network elements in the provision of telecommunications services.
- 5.1.1 Such equipment must at a minimum meet the following BellCore (Telcordia) Network Equipment Building Systems (NEBS) General Equipment Requirements: Criteria Level 3 requirements as outlined in the BellCore (Telcordia) Special Report SR-3580, Issue 1; equipment design spatial requirements per GR-63-CORE, Section 2; thermal heat dissipation per GR-063-CORE, Section 4, Criteria 77-79; acoustic noise per GR-063-CORE, Section 4, Criterion 128, and National Electric Code standards. Except where otherwise required by a Commission, BellSouth shall comply with the applicable FCC rules relating to denial of collocation based on Heritage's failure to comply with these requirements.
- 5.1.2 Heritage shall not use the Remote Collocation Space for marketing purposes nor shall it place any identifying signs or markings in the area surrounding the Remote Collocation Space or on the grounds of the Remote Site Location.

- 5.1.3 Heritage shall place a plaque or other identification affixed to Heritage's equipment to identify Heritage's equipment, including a list of emergency contacts with telephone numbers.
- 5.1.4 All Heritage equipment installation shall comply with BellSouth TR 73503-11, Section 8, "Grounding - Engineering Procedures". Metallic cable sheaths and metallic strength members of optical fiber cables as well as the metallic cable sheaths of all copper conductor cables shall be bonded to the designated grounding bus for the Remote Site Location. All copper conductor pairs, working and non-working, shall be equipped with a solid state protector unit (over-voltage protection only) which has been listed by a nationally recognized testing laboratory.
- 5.2 **Entrance Facilities.** Heritage may elect to place Heritage-owned or Heritage-leased entrance facilities into the Remote Collocation Space from Heritage's point of presence. BellSouth will designate the point of interconnection at the Remote Site Location housing the Remote Collocation Space, which is physically accessible by both Parties. Heritage will provide and place copper cable through conduit from the Remote Collocation Space to the Feeder Distribution Interface to the splice location of sufficient length for splicing by BellSouth. Heritage must contact BellSouth for instructions prior to placing the entrance facility cable. Heritage is responsible for maintenance of the entrance facilities.
- 5.2.1 **Shared Use.** Heritage may utilize spare capacity on an existing interconnector entrance facility for the purpose of providing an entrance facility to Heritage's collocation arrangement within the same BellSouth Remote Site Location.
- 5.3 **Demarcation Point.** BellSouth will designate the point(s) of demarcation between Heritage's equipment and/or network and BellSouth's network. Each Party will be responsible for maintenance and operation of all equipment/facilities on its side of the demarcation point. Heritage or its agent must perform all required maintenance to Heritage equipment/facilities on its side of the demarcation point, pursuant to Section 5.4, following.
- 5.4 **Heritage's Equipment and Facilities.** Heritage, or if required by this Attachment, Heritage's Certified Supplier, is solely responsible for the design, engineering, installation, testing, provisioning, performance, monitoring, maintenance and repair of the equipment and facilities used by Heritage.
- 5.5 **BellSouth's Access to Remote Collocation Space.** BellSouth retains the right to access the Remote Collocation Space for the purpose of making BellSouth equipment and Remote Site Location modifications.
- 5.6 **Access.** Pursuant to Section 12, Heritage shall have access to the Remote Collocation Space twenty-four (24) hours a day, seven (7) days a week. Heritage agrees to provide the name and social security number or date of birth or driver's license number

of each employee, contractor, or agents of Heritage or Heritage's Guests provided with access keys or devices ("Access Keys") prior to the issuance of said Access Keys. Key acknowledgement forms must be signed by Heritage and returned to BellSouth Access Management within fifteen (15) calendar days of Heritage's receipt. Failure to return properly acknowledged forms will result in the holding of subsequent requests until acknowledgements are current. Access Keys shall not be duplicated under any circumstances. Heritage agrees to be responsible for all Access Keys and for the return of all said Access Keys in the possession of Heritage employees, contractors, Guests, or agents after termination of the employment relationship, contractual obligation with Heritage or upon the termination of this Attachment or the termination of occupancy of an individual Remote Site collocation arrangement.

- 5.6.1 Heritage must submit to BellSouth the completed Access Control Request Form for all employees or agents requiring access to the BellSouth Premises a minimum of thirty (30) calendar days prior to the date Heritage desires access to the Collocation Space. In order to permit reasonable access during construction of the Collocation Space, Heritage may submit such a request at any time subsequent to BellSouth's receipt of the Bona Fide Firm Order. In the event Heritage desires access to the Collocation Space after submitting such a request but prior to access being approved, BellSouth shall permit Heritage to access the Collocation Space accompanied by a security escort at Heritage's expense. Heritage must request escorted access at least three (3) business days prior to the date such access is desired.
- 5.7 **Lost or Stolen Access Keys.** Heritage shall notify BellSouth in writing immediately in the case of lost or stolen Access Keys. Should it become necessary for BellSouth to re-key Remote Site Locations as a result of a lost Access Key(s) or for failure to return an Access Key(s), Heritage shall pay for all reasonable costs associated with the re-keying.
- 5.8 **Interference or Impairment.** Notwithstanding any other provisions of this Attachment, **equipment and facilities** placed in the Remote Collocation Space shall **not** significantly degrade, interfere with or impair service provided by BellSouth or by any other interconnector located in the Remote Site Location; shall not endanger or **damage the facilities** of BellSouth or of any other interconnector, the Remote Collocation Space, or the Remote Site Location; shall not compromise the privacy of any **communications** carried in, from, or through the Remote Site Location; and shall not create an unreasonable risk of injury or death to any individual or to the public. If BellSouth reasonably determines that any **equipment** or **facilities** of Heritage violates the provisions of this paragraph, BellSouth shall **give** written notice to Heritage, which notice shall **direct** Heritage to **cure** the violation within forty-eight (48) hours of Heritage's actual receipt of written notice or, at a **minimum**, to **commence curative measures** within 24 hours and to exercise reasonable diligence to complete such **measures** as soon as possible **thereafter**. After receipt of the **notice**, the Parties agree to consult immediately and, if necessary, to inspect **the** arrangement.

- 5.8.1 Except in the case of the deployment of an advanced service which significantly degrades the performance of other advanced services or traditional voice band services, if Heritage fails to take curative action within 48 hours or if the violation is of a character which poses an immediate and substantial threat of damage to property, injury or death to any person, or other interference/impairment of the services provided by BellSouth or any other interconnector, then and only in that event BellSouth may take such action as it deems appropriate to correct the violation, including without limitation the interruption of electrical power to Heritage's equipment. BellSouth will endeavor, but is not required, to provide notice to Heritage prior to taking such action and shall have no liability to Heritage for any damages arising from such action, except to the extent that such action by BellSouth constitutes willful misconduct.
- 5.8.2 For purposes of this section, the term significantly degrade shall mean an action that noticeably impairs a service from a user's perspective. In the case of the deployment of an advanced service which significantly degrades the performance of other advanced services or traditional voice band services and Heritage fails to take curative action within 48 hours then BellSouth will establish before the relevant Commission that the technology deployment is causing the significant degradation. Any claims of network harm presented to Heritage or, if subsequently necessary, the relevant Commission must be supported with specific and verifiable information. Where BellSouth demonstrates that a deployed technology is significantly degrading the performance of other advanced services or traditional voice band services, Heritage shall discontinue deployment of that technology and migrate its customers to technologies that will not significantly degrade the performance of other such services. Where the only degraded service itself is a known disturber, and the newly deployed technology satisfies at least one of the criteria for a presumption that is acceptable for deployment under 47 C.F.R. 51.230, the degraded service shall not prevail against the newly-deployed technology.
- 5.9 Presence of Facilities. Facilities and equipment placed by Heritage in the Remote Collocation Space shall not become a part of the Remote Site Location, even if nailed, screwed or otherwise fastened to the Remote Collocation Space but shall retain its status as personal property and may be removed by Heritage at any time. Any damage caused to the Remote Collocation Space by Heritage's employees, agents or representatives shall be promptly repaired by Heritage at its expense.
- 5.10 Alterations. In no case shall Heritage or any person acting on behalf of Heritage make any rearrangement, modification, improvement, addition, or other alteration which could affect in any way space, power, HVAC, and/or safety considerations to the Remote Collocation Space or the BellSouth Remote Site Location without the written consent of BellSouth, which consent shall not be unreasonably withheld. The cost of any specialized alterations shall be paid by Heritage. Any material rearrangement, modification, improvement, addition, or other alteration shall require an Application Fee.

- 5.11 **Upkeep of Remote Collocation Space.** Heritage shall be responsible for the general upkeep and cleaning of the Remote Collocation Space. Heritage shall be responsible for removing any Heritage debris from the Remote Collocation Space and from in and around the Remote Collocation Site on each visit.
6. **Space Notification**
- 6.1 Should any state or federal regulatory agency impose procedures or intervals applicable to Heritage and BellSouth that are different from procedures or intervals set forth in this section, whether now in effect or that become effective after execution of this Agreement, those procedures or intervals shall supersede the requirements set forth herein for that jurisdiction for all applications submitted for the first time after the effective date thereof
- 6.2 **Application for Space.** Heritage shall submit a Remote Site Collocation Application when Heritage or Heritage's Guest(s), as defined in Section 3, desires to request or modify the use of the Remote Collocation Space.
- 6.3 **Initial Application.** For Heritage or Heritage's Guest(s) equipment placement, Heritage shall submit to BellSouth an Application. The Application is Bona Fide when it is complete and accurate, meaning that all required fields on the Application are completed with the appropriate type of information. Prior to submitting the application, CLLI information can be obtained in the manner set forth in Section 2. An Application Fee will apply.
- 6.4 **Subsequent Application** In the event Heritage or Heritage's Guest(s) desires to modify the use of the Collocation Space after Bona Fide Firm Order, Heritage shall complete an Application detailing all information regarding the modification to the Collocation Space ("Subsequent Application"). BellSouth shall determine what modifications, if any, to the Premises are required to accommodate the change requested by Heritage in the Application. Such necessary modifications to the Premises may include, but are not limited to, floor loading changes, changes necessary to meet HVAC requirements, changes to power plant requirements, equipment additions, etc.
- 6.4.1 **Subsequent Application Fee.** The application fee paid by Heritage for its request to modify the use of the Collocation Space shall be dependent upon the level of assessment needed for the modification requested. Where the Subsequent Application does not require assessment for provisioning or construction work by BellSouth, no Subsequent Application fee will be required. The fee for a Subsequent Application where the modification requested has limited effect (e.g., requires limited assessment and no capital expenditure by BellSouth) shall be the Subsequent Application Fee as set forth in Exhibit D. If the modification requires capital expenditure assessment, a

full Application Fee shall apply. The Subsequent Application is Bona Fide when it is complete and accurate, meaning that all required fields on the Application are completed with the appropriate type of information.

- 6.5 Availability of Space. Upon submission of an Application, BellSouth will permit Heritage to physically collocate, pursuant to the terms of this Attachment, at any BellSouth Remote Site Location, unless BellSouth has determined that there is no space available due to space limitations or that Remote Site Collocation is not practical for technical reasons. In the event space is not immediately available at a Remote Site Location, BellSouth reserves the right to make additional space available, in which case the conditions in Section 7 shall apply, or BellSouth may elect to deny space in accordance with this section in which case virtual or adjacent collocation options may be available. If the amount of space requested is not available, BellSouth will notify Heritage of the amount that is available.
- 6.5.1 Availability Notification. Unless otherwise specified, BellSouth will respond to an application within ten (10) calendar days (In Mississippi, ten (10) business days) as to whether space is available or not available within a BellSouth Remote Site Location. With the exception of Georgia, this interval excludes National Holidays. If the amount of space requested is not available, BellSouth will notify Heritage of the amount of space that is available and no Application Fee shall apply. When BellSouth's response includes an amount of space less than that requested by Heritage, Heritage must resubmit its Application to reflect the actual space available.
- 6.5.2 BellSouth will respond to a Florida Application within fifteen (15) calendar days as to whether space is available or not available within a BellSouth Remote Site Location. BellSouth will also respond as to whether the Application is Bona Fide and if it is not Bona Fide the items necessary to cause the Application to become Bona Fide. If a lesser amount of space than requested is available, BellSouth will provide an Application Response for the amount of space that is available and an Application Fee will be assessed. When BellSouth's Application Response includes an amount of space less than that requested by Heritage, Heritage must amend its Application to reflect the actual space available prior to submitting Bona Fide Firm Order.
- 6.5.3 BellSouth will respond to a Louisiana Application within ten (10) calendar days for space availability for one (1) to ten (10) Applications; fifteen (15) calendar days for eleven (11) to twenty (20) Applications; and for more than twenty (20) Applications, it is increased by five (5) calendar days for every five additional Applications received within five (5) business days. If the amount of space requested is not available, BellSouth will notify Heritage of the amount of space that is available and no Application Fee will apply. When BellSouth's response includes an amount of space less than that requested by Heritage, Heritage must resubmit its Application to reflect the actual space available. BellSouth will also respond as to whether the Application is Bona Fide and if it is not Bona Fide the items necessary to cause the Application to become Bona Fide.

- 6.6 **Denial of Application.** If BellSouth notifies Heritage that no space is available (“Denial of Application”), BellSouth will not assess an Application Fee. After notifying Heritage that BellSouth has no available space in the requested Remote Site Location, BellSouth will allow Heritage, upon request, to tour the Remote Site Location within ten (10) calendar days of such Denial of Application. With the exception of Georgia, this interval excludes national holidays. In order to schedule said tour within ten (10) calendar days, the request for a tour of the Remote Site Location must be received by BellSouth within five (5) calendar days of the Denial of Application. In Mississippi the above intervals shall be in business days.
- 6.7 **Filing of Petition for Waiver.** Upon Denial of Application BellSouth will timely file a petition with the Commission pursuant to 47 U.S.C. § 251(c)(6). BellSouth shall provide to the Commission any information requested by that Commission. Such information shall include which space, if any, BellSouth or any of BellSouth’s affiliates have reserved for future use and a detailed description of the specific future uses for which the space has been reserved. Subject to an appropriate nondisclosure agreement or provision, BellSouth shall permit Heritage to inspect any plans or diagrams that BellSouth provides to the Commission.
- 6.8 **Waiting List.** On a first-come, first-served basis governed by the date of receipt of an Application or Letter of Intent, BellSouth will maintain a waiting list of requesting carriers who have either received a Denial of Application or, where it is publicly known that the Premises is out of space, have submitted a Letter of Intent to collocate. BellSouth will notify the telecommunications carriers on the waiting list that can be accommodated by the amount of space that becomes available according to the position of the telecommunications carriers on said waiting list
- 6.8.1 In Florida, on a first-come, first-served basis governed by the date of receipt of an Application or Letter of Intent, BellSouth will maintain a waiting list of requesting carriers who have either received a Denial of Application or, where it is publicly known that the Remote Site Location is out of space, have submitted a Letter of Intent to collocate. Sixty (60) days prior to space becoming available, if known, BellSouth will notify the Florida PSC and the telecommunications carriers on the waiting list by mail when space becomes available according to the position of telecommunications carrier on said waiting list. If not known sixty (60) days in advance, BellSouth shall notify the Florida PSC and the telecommunications carriers on the waiting list within two days of the determination that space is available. A CLEC that, upon denial of physical collocation, requests virtual collocation shall be automatically placed on the waiting list.
- 6.8.2 When space becomes available, Heritage must submit an updated, complete, and correct Application to BellSouth within 30 calendar days (in Mississippi, 30 business days) of such notification. Heritage may accept an amount of space less than its original request by submitting an Application as set forth above, and upon request,

may maintain its position on the waiting list for the remaining space that was initially requested. If Heritage does not submit such an Application or notify BellSouth in writing as described above, BellSouth will offer such space to the next CLEC on the waiting list and remove Heritage from the waiting list. Upon request, BellSouth will advise Heritage as to its position on the list.

- 6.9 **Public Notification.** BellSouth will maintain on its Interconnection Services website a notification document that will indicate all Remote Site Locations that are without available space. BellSouth shall update such document within ten (10) calendar days (in Mississippi, 10 business days) of the Denial of Application date. This interval excludes national holidays. BellSouth will also post a document on its Interconnection Services website that contains a general notice where space has become available in a Remote Site Location previously on the space exhaust list.
- 6.10 **Application Response.**
- 6.10.1 **Application Response.** In Alabama, Kentucky, North Carolina, and Tennessee, when space has been determined to be available, BellSouth will provide a written response (“Application Response”) within twenty-three (23) business days of the receipt of a Bona Fide Application, which will include, at a minimum, the configuration of the space, the Cable Installation Fee, Cable Records Fee, and the space preparation fees, as described in Section 8.
- 6.10.2 Except as otherwise provided, for all States that have ordered provisioning intervals but not application response intervals, BellSouth will provide a written response (“Application Response”) within thirty (30) calendar days of receipt of a Bona Fide Application. The Application Response will include, at a **minimum**, the estimated provisioning interval, any additional engineering charges, if applicable, and any other additional information that may extend the ordinary interval to extraordinary interval status, together with sufficient information to explain such extension.
- 6.10.2.1 When multiple applications are submitted in a state within a fifteen (15) calendar day window, BellSouth will respond to the Bona Fide Applications as soon as possible, but no later than the following: within thirty (30) calendar days for Bona Fide Applications 1-5; within thirty-six (36) calendar days for Bona Fide Applications 6-10; within forty-two (42) calendar days for Bona Fide Applications 11-15. Response intervals for multiple Bona Fide Applications submitted within the same timeframe for the same state in excess of 15 must be negotiated. All negotiations shall consider the total volume from all requests from telecommunications companies for collocation.
- 6.10.3 In Florida, when space has been determined to be available or when a lesser amount of space than that requested is available, then with respect to the space available, BellSouth will provide a written response (“Application Response”) including sufficient information to enable Heritage to place a Firm Order. When Heritage submits ten (10) or more Applications within ten (10) calendar days, the initial fifteen

(15) day response period will increase by ten (10) days for every additional ten (10) Applications or fraction thereof.

6.10.4 In Georgia, when space has been determined to be available, BellSouth will provide a written response ("Application Response") within thirty (30) calendar days of receipt of a Bona Fide Application. The Application Response will include, at a minimum, the estimated provisioning interval, any additional engineering charges, if applicable, and any other additional information that may extend the ordinary interval to extraordinary interval status, together with sufficient information to explain such extension.

6.10.5 In Louisiana, BellSouth will respond with a full Application Response within thirty (30) calendar days for one (1) to ten (10) Applications; thirty (35) calendar days for eleven (11) to twenty (20) Applications; and for requests of more than twenty (20) Applications, it is increased by five (5) calendar days for every five Applications received within five (5) business days. The Application Response will include, at a minimum, the estimated provisioning interval, any additional engineering charges, if applicable, and any other additional information that may extend the ordinary interval to extraordinary interval status, together with sufficient information to explain such extension.

6.11 Application Modifications.

6.11.1 If a modification or revision is made to any information in the Bona Fide Application prior to Bona Fide Firm Order, with the exception of modifications to Customer Information, Contact Information or Billing Contact Information, either at the request of Heritage or necessitated by technical considerations, said Application shall be considered a new Application and shall be handled as a new Application with respect to response and provisioning intervals and BellSouth may charge Heritage an application fee. Where the Application Modification does not require assessment for provisioning or construction work by BellSouth, no application fee will be required. The fee for an Application Modification where the modification requested has limited effect (e.g., requires limited assessment and no capital expenditure by BellSouth) shall be the Subsequent Application Fee as set forth in Exhibit D. Major changes such as requesting additional space or adding equipment may require Heritage to submit the Application with an Application Fee.

6.12 Bona Fide Firm Order.

6.12.1 ~~Bona Fide Firm Order.~~ In Alabama, Kentucky, North Carolina, and Tennessee, Heritage shall indicate its intent to proceed with equipment installation in a BellSouth Premises by submitting a Physical Expanded Interconnection Firm Order document ("Firm Order") to BellSouth. A Firm Order shall be considered Bona Fide when Heritage has completed the Application/Inquiry process described in Section 6.2, preceding, and has submitted the Firm Order document indicating acceptance of the Application Response provided by BellSouth. The Bona Fide Firm Order must be

received by BellSouth no later than five (5) business days after BellSouth's Application Response to Heritage's Bona Fide Application.

- 6.12.2 Except as otherwise provided, in all States that have ordered provisioning intervals but not addressed Firm Order intervals, the following shall apply. Heritage shall indicate its intent to proceed with equipment installation in a BellSouth Remote Site Location by submitting a Physical Expanded Interconnection Firm Order document ("Firm Order") to BellSouth. A Firm Order shall be considered Bona Fide when Heritage has completed the Application/Inquiry process described in this Section 6, preceding and has submitted the Firm Order document indicating acceptance of the Application Response provided by BellSouth. The Bona Fide Firm Order must be received by BellSouth no later than thirty (30) calendar days (in Mississippi 30 business days) after BellSouth's Application Response to Heritage's Bona Fide Application or the Application will expire.
- 6.12.3 In Mississippi, Heritage shall indicate its intent to proceed with equipment installation in a BellSouth Remote Terminal Location by submitting a Physical Expanded Interconnection Firm Order document ("Firm Order") to BellSouth. A Firm Order shall be considered Bona Fide when Heritage has completed the Application/Inquiry process described in Section 6, preceding and has submitted the Firm Order document indicating acceptance of the Application Response provided by BellSouth. The Bona Fide Firm Order must be received by BellSouth no later than thirty (30) business days after BellSouth's Application Response to Heritage's Bona Fide Application or the Application will expire.
- 6.12.4 BellSouth will establish a firm order date based upon the date BellSouth is in receipt of a Bona Fide Firm Order. BellSouth will acknowledge the receipt of Heritage's Bona Fide Firm Order within seven (7) calendar days of receipt indicating that the Bona Fide Firm Order has been received. A BellSouth response to a Bona Fide Firm Order will include a Firm Order Confirmation containing the firm order date. No revisions will be made to a Bona Fide Firm Order.
- 6.13 BellSouth will permit one accompanied site visit to Heritage's designated Remote Collocation Space after receipt of the Bona Fide Firm Order without charge to Heritage.

7. Construction and Provisioning

7.1 Construction and Provisioning Intervals.

- 7.1.1 In Alabama (Caged Only), Kentucky, North Carolina and Tennessee, BellSouth will complete **construction for collocation arrangements** within seventy-six (76) business days from receipt of an Application or as agreed to by the Parties. Under extraordinary conditions, BellSouth will complete construction for collocation arrangements within ninety-one (91) business days. **Examples** of extraordinary

conditions include, but are not limited to, extended license or permitting intervals; major BellSouth equipment rearrangement or addition; power plant addition or upgrade; major mechanical addition or upgrade; major upgrade for ADA compliance; environmental hazard or hazardous materials abatement; and arrangements for which equipment shipping intervals are extraordinary in length. In the event Heritage submits a forecast as described in the following section three (3) months or more prior to the application date, the above intervals shall apply. In the event Heritage submits such a forecast between two (2) months and three (3) months prior to the application date, the above intervals may be extended by one (1) additional month. In the event Heritage submits such a forecast less than two (2) months prior to the application date, the above intervals may be extended by sixty (60) calendar days. BellSouth will attempt to meet standard intervals for unforecasted requests and any interval adjustments will be discussed with Heritage at the time the application is received. Raw space, which is space lacking the necessary infrastructure to provide collocation space including but not limited to HVAC, Power, etc.), conversion time frames fall outside the normal intervals and are negotiated on an individual case basis. Additionally, installations to existing collocation arrangements for line sharing or line splitting, which include adding cable, adding cable and splitter, and adding a splitter, will be forty five (45) business days from receipt of an Application.

- 7.1.1.1 To be considered a timely and accurate forecast, Heritage must submit to BellSouth the CLEC Forecast Form, as set forth in exhibit C attached hereto, containing the following information: Central Office/Serving Wire Center CLLI, Remote Site CLLI, number of bays, number of DS0, DS1, DS3 terminations, equipment power requirements (power drain) and planned application date.
- 7.1.2 In Alabama, BellSouth will complete construction for cageless collocation arrangements under ordinary conditions as soon as possible and within a maximum of sixty (60) calendar days from receipt of a Bona Fide Firm Order and ninety (90) calendar days for extraordinary conditions or as agreed to by the Parties. Ordinary conditions are defined as space available with only minor changes to support systems required, such as but not limited to, HVAC, cabling and the power plant(s). Extraordinary conditions are defined to include but are not limited to major BellSouth equipment rearrangement or addition; power plant addition or upgrade; major mechanical addition or upgrade; major upgrade for ADA compliance; environmental hazard or hazardous materials abatement; and arrangements for which equipment shipping intervals are extraordinary in length. The Parties may mutually agree to renegotiate an alternative provisioning interval or BellSouth may seek a waiver from this interval from the Commission.
- 7.1.3 In Florida, BellSouth will complete construction for collocation arrangements as soon as possible and within a maximum of ninety (90) calendar days from receipt of a Bona Fide Firm Order or as agreed to by the Parties. For changes to collocation space after initial space completion ("Augmentation"), BellSouth will complete construction for collocation arrangements as soon as possible and within a maximum of forty-five (45)

calendar days from receipt of a Bona Fide Firm Order or as agreed to by the Parties. If BellSouth does not believe that construction will be completed within the relevant time frame and BellSouth and Heritage cannot agree upon a completion date, within 45 calendar days of receipt of the Bona Fide Firm Order for an initial request, and within 30 calendar days for Augmentations, BellSouth may seek an extension from the Florida PSC.

- 7.1.4 In Georgia, BellSouth will complete construction for caged collocation arrangements under ordinary conditions as soon as possible and within a maximum of ninety (90) calendar days from receipt of a Bona Fide Firm Order or as agreed to by the Parties. BellSouth will complete construction for cageless collocation arrangements under ordinary conditions as soon as possible and within a maximum of 60 calendar days from receipt of a Bona Fide Firm Order and 90 calendar days for extraordinary conditions or as agreed to by the Parties. Ordinary conditions are defined as space available with only minor changes to support systems required, such as but not limited to, HVAC, cabling and the power plant(s). Extraordinary conditions are defined to include but are not limited to major BellSouth equipment rearrangement or addition; power plant addition or upgrade; major mechanical addition or upgrade; major upgrade for ADA compliance; environmental hazard or hazardous materials abatement; and arrangements for which equipment shipping intervals are extraordinary in length. The Parties may mutually agree to renegotiate an alternative provisioning interval or BellSouth may seek a waiver from this interval from the Commission.
- 7.1.5 In Louisiana, BellSouth will complete construction for collocation arrangements under ordinary conditions as soon as possible and within a maximum of 120 calendar days from receipt of a Bona Fide Firm Order for an initial request, and within 60 calendar days for an Augmentation, or as agreed to by the Parties. Ordinary conditions are defined as space available with only minor changes to support systems required, such as but not limited to, HVAC, cabling and the power plant(s). BellSouth will complete construction of all other Collocation Space ("extraordinary conditions") within 120 calendar days of the receipt of a Bona Fide Firm Order. Examples of extraordinary conditions include but are not limited to, extended license or permitting intervals; major BellSouth equipment rearrangement or addition; power plant addition or upgrade; major mechanical addition or upgrade; major upgrade for ADA compliance; environmental hazard or hazardous materials abatement; and arrangements for which equipment shipping intervals are extraordinary in length. The Parties may mutually agree to renegotiate an alternative provisioning interval or BellSouth may seek a waiver from this interval from the Commission.
- 7.1.6 In Mississippi, excluding the time interval required to secure the appropriate government licenses and permits, BellSouth will complete construction for collocation arrangements under ordinary conditions as soon as possible and within a maximum of 120 calendar days from receipt of a Bona Fide Firm Order or as agreed to by the Parties. Ordinary conditions are defined as space available with only minor changes to support systems required, such as but not limited to, HVAC, cabling and the power

plant(s). Excluding the time interval required to secure the appropriate government licenses and permits, BellSouth will complete construction of all other Collocation Space ("extraordinary conditions") within 180 calendar days of the receipt of a Bona Fide Firm Order. Examples of extraordinary conditions include but are not limited to, extended license or permitting intervals; major BellSouth equipment rearrangement or addition; power plant addition or upgrade; major mechanical addition or upgrade; major upgrade for ADA compliance; environmental hazard or hazardous materials abatement; and arrangements for which equipment shipping intervals are extraordinary in length. The Parties may mutually agree to renegotiate an alternative provisioning interval or BellSouth may seek a waiver from this interval from the Commission.

- 7.1.7 In South Carolina, BellSouth will complete the construction and provisioning activities for collocation arrangements as soon as possible, but no later than 90 calendar days from receipt of a bona fide firm order. The Parties may mutually agree to renegotiate an alternative provisioning interval or BellSouth may seek a waiver from this interval from the Commission.
- 7.2 In the event BellSouth does not have space immediately available at a Remote Site Location, BellSouth may elect to make additional space available by, for example but not limited to, rearranging BellSouth facilities or constructing additional capacity. In such cases, the above intervals shall not apply and BellSouth will provision the Remote Collocation Space in a nondiscriminatory manner and at parity with BellSouth and will provide Heritage with the estimated completion date in its Response.
- 7.3 Permits. Each Party or its agents will diligently pursue filing for the permits required for the scope of work to be performed by that Party or its agents within ten (10) calendar days of the completion of finalized construction designs and specifications.
- 7.4 Acceptance Walk Through. Heritage will schedule and complete an acceptance walk through of each Collocation Space with BellSouth within fifteen (15) days of BellSouth's notifying Heritage that the collocation space is ready for occupancy. BellSouth will correct any deviations to Heritage's original or jointly amended requirements within seven (7) calendar days after the walk through, unless the Parties jointly agree upon a different time frame.
- 7.5 Use of BellSouth Certified Supplier. Heritage shall select a supplier that has been approved by BellSouth to perform all engineering and installation work required in the Remote Collocation Space per TR 73503 specifications ("Certified Supplier"). BellSouth shall provide Heritage with a list of Certified Suppliers upon request. The Certified Supplier(s) shall be responsible for installing Heritage's equipment and components, extending power cabling to the BellSouth power distribution frame, performing operational tests after installation is complete, and notifying BellSouth's Outside Plant engineers and Heritage upon successful completion of installation. The Certified Supplier shall bill Heritage directly for all work performed for Heritage pursuant to this Attachment and BellSouth shall have no liability for nor responsibility

to pay such charges imposed by the Certified Supplier. BellSouth shall consider certifying Heritage or any supplier proposed by Heritage. All work performed by or for Heritage shall conform to generally accepted industry guidelines and standards.

- 7.6 Alarm and Monitoring. BellSouth may place alarms in the Remote Site Location for the protection of BellSouth equipment and facilities. Heritage shall be responsible for placement, monitoring and removal of alarms used to service Heritage's Remote Collocation Space and for ordering the necessary services therefor. Both Parties shall use best efforts to notify the other of any verified hazardous conditions known to that Party.
- 7.7 Virtual Remote Site Collocation Relocation. BellSouth offers Virtual Collocation pursuant to the terms and conditions set forth in its F.C.C. Tariff No. 1 for Remote Site Collocation locations. The rates shall be the same as provided in this Exhibit D of this agreement. Heritage may place within its Virtual Collocation arrangements the telecommunications equipment set forth in Section 5. In the event physical Remote Collocation Space was previously denied at a Remote Site Location due to technical reasons or space limitations, and that physical Remote Collocation Space has subsequently become available, Heritage may relocate its virtual Remote Site collocation arrangements to physical Remote Site collocation arrangements and pay the appropriate non-recurring fees for physical Remote Site collocation and for the rearrangement or reconfiguration of services terminated in the virtual Remote Site collocation arrangement, as outlined in the appropriate BellSouth tariffs. In the event that BellSouth knows when additional space for physical Remote Site collocation may become available at the location requested by Heritage, such information will be provided to Heritage in BellSouth's written denial of physical Remote Site collocation. To the extent that (i) physical Remote Collocation Space becomes available to Heritage within 180 calendar days of BellSouth's written denial of Heritage's request for physical collocation, and (ii) Heritage was not informed in the written denial that physical Remote Collocation Space would become available within such 180 calendar days, then Heritage may relocate its virtual Remote Site collocation arrangement to a physical Remote Site collocation arrangement and will receive a credit for any nonrecurring charges previously paid for such virtual Remote Site collocation. Heritage must arrange with a BellSouth Certified Supplier for the relocation of equipment from its virtual Remote Collocation Space to its physical Remote Collocation Space and will bear the cost of such relocation.
- 7.8 Cancellation. If, at anytime prior to space acceptance, Heritage cancels its order for the Remote Collocation Space(s), Heritage will reimburse BellSouth for the applicable non recurring rate for any and all work processes for which work has begun.
- 7.9 Licenses. Heritage, at its own expense, will be solely responsible for obtaining from governmental authorities, and any other appropriate agency, entity, or person, all rights, privileges, and licenses necessary or required to operate as a provider of telecommunications services to the public or to occupy the Remote Collocation Space.

- 7.10 Environmental Hazard Guidelines. The Parties agree to utilize and adhere to the Environmental Hazard Guidelines identified as Exhibit A attached hereto.
8. Rates and Charges
- 8.1 Application Fee. BellSouth will assess an Application Fee on a service order which shall be issued at the time BellSouth responds that space is available. Payment of the Application Fee will be due as dictated by Heritage's current billing cycle and is non-refundable.
- 8.2 Recurring Charges. Recurring charges begin on the date that Heritage executes the written document accepting the Remote Collocation Space pursuant to Section 7, or on the date Heritage first occupies the Remote Collocation Space, whichever is sooner. If Heritage fails to schedule and complete a walkthrough pursuant to Section 7 within fifteen (15) days after BellSouth releases the space for occupancy, then BellSouth shall begin billing Heritage for recurring charges as of the sixteenth (16) day after BellSouth releases the Remote Collocation Space. Other charges shall be billed upon request for the services. All charges shall be due as dictated by Heritage's current billing cycle.
- 8.3 Rack/Bay Space. The rack/bay space charge includes reasonable charges for air conditioning, ventilation and other allocated expenses associated with maintenance of the Remote Site Location, and includes amperage necessary to power Heritage's equipment. Heritage shall pay rack/bay space charges based upon the number of racks/bays requested. BellSouth will assign Remote Collocation Space in conventional remote site rack/bay lineups where feasible
- 8.4 Power. BellSouth shall make available -48 Volt (-48V) DC power for Heritage's Remote Collocation Space at a BellSouth Power Board (Fuse and Alarm Panel) or BellSouth Battery Distribution Fuse Bay ("BDFB") at Heritage's option within the Remote Site Location. The charge for power shall be assessed as part of the recurring charge for rack/bay space. If the power requirements for Heritage's equipment exceeds the capacity for the rack/bay, then such power requirements shall be assessed on a recurring per amp basis for the individual case.
- 8.4.1 Charges for AC power will be assessed per breaker ampere per month. Rates include the provision of commercial and standby AC power, where available. When obtaining power from a BellSouth service panel, protection devices and power cables must be engineered (sized), and installed by Heritage's BellSouth Certified Supplier except that BellSouth shall engineer and install protection devices and power cables for Adjacent Collocation. Heritage's BellSouth Certified Supplier must also provide a copy of the engineering power specification prior to the Commencement Date. AC power voltage

and phase ratings shall be determined on a per location basis. At Heritage's option, Heritage may arrange for AC power in an Adjacent Collocation arrangement from a retail provider of electrical power.

- 8.5 **Security Escort.** A security escort will be required whenever Heritage or its approved agent desires access to the Remote Site Location after the one accompanied site visit allowed prior to completing BellSouth's Security Training requirements. The parties will negotiate appropriate security escort rates which will be assessed on a one half (1/2) hour increment basis.
- 8.6 **Rate "True-Up".** The Parties agree that the prices reflected as interim herein shall be "true-up" (up or down) based on final prices either determined by further agreement or by an effective order, in a proceeding involving BellSouth before the regulatory authority for the state in which the services are being performed or any other body having jurisdiction over this Agreement (hereinafter "Commission"). Under the "true-up" process, the interim price for each service shall be multiplied by the volume of that service purchased to arrive at the total interim amount paid for that service ("Total Interim Price"). The final price for that service shall be multiplied by the volume purchased to arrive at the total final amount due ("Total Final Price"). The Total Interim Price shall be compared with the Total Final Price. If the Total Final Price is more than the Total Interim Price, Heritage shall pay the difference to BellSouth. If the Total Final Price is less than the Total Interim Price, BellSouth shall pay the difference to Heritage. Each Party shall keep its own records upon which a "true-up" can be based and any final payment from one Party to the other shall be in an amount agreed upon by the Parties based on such records. In the event of any disagreement as between the records or the Parties regarding the amount of such "true-up," the Parties agree that the Commission shall be called upon to resolve such differences.
- 8.7 **Other.** If no rate is identified in the contract, the rate for the specific service or function will be negotiated by the Parties upon request by either Party. Payment of all other charges under this Attachment shall be due as dictated by Heritage's current billing cycle. Heritage will pay a late payment charge of the lessor of one and one half percent or the legal interest rate assessed monthly on any balance which remains unpaid after the payment due date..
9. **Insurance**
- 9.1 **Maintain Insurance.** Heritage shall, at its sole cost and expense, procure, maintain, and keep in force insurance as specified in this Section 9 and underwritten by insurance companies licensed to do business in the states applicable under this Attachment and having a Best's Insurance Rating of A-.
- 9.2 **Coverage.** Heritage shall maintain the following specific coverage:

- 9.2.1 Commercial General Liability coverage in the amount of ten million dollars (\$10,000,000.00) or a combination of Commercial General Liability and Excess/Umbrella coverage totaling not less than ten million dollars (\$10,000,000.00). BellSouth shall be named as an Additional Insured on the Commercial General Liability policy as specified herein.
- 9.2.2 Statutory Workers Compensation coverage and Employers Liability coverage in the amount of one hundred thousand dollars (\$100,000.00) each accident, one hundred thousand dollars (\$100,000.00) each employee by disease, and five hundred thousand dollars (\$500,000.00) policy limit by disease.
- 9.2.3 All Risk Property coverage on a full replacement cost basis insuring all of Heritage's real and personal property situated on or within BellSouth's Remote Site Location.
- 9.2.4 Heritage may elect to purchase business interruption and contingent business interruption insurance, having been advised that BellSouth assumes no liability for loss of profit or revenues should an interruption of service occur.
- 9.3 Limits. The limits set forth in Section 9.2 above may be increased by BellSouth from time to time during the term of this Attachment upon thirty (30) days notice to Heritage to at least such minimum limits as shall then be customary with respect to comparable occupancy of BellSouth structures.
- 9.4 All policies purchased by Heritage shall be deemed to be primary. All policies purchased by Heritage shall be deemed to be primary and not contributing to or in excess of any similar coverage purchased by BellSouth. All insurance must be in effect on or before the date equipment is delivered to BellSouth's Remote Site Location and shall remain in effect for the term of this Attachment or until all Heritage's property has been removed from BellSouth's Remote Site Location, whichever period is longer. If Heritage fails to maintain required coverage, BellSouth may pay the premiums thereon and seek reimbursement of same from Heritage.
- 9.5 Submit certificates of insurance. Heritage shall submit certificates of insurance reflecting the coverage required pursuant to this Section a minimum of ten (10) business days prior to the commencement of any work in the Remote Collocation Space. Failure to meet this interval may result in construction and equipment installation delays. Heritage shall arrange for BellSouth to receive thirty (30) business days' advance notice of cancellation from Heritage's insurance company. Heritage shall forward a certificate of insurance and notice of cancellation/non-renewal to BellSouth at the following address:

BellSouth Telecommunications, Inc.
Attn.: Risk Management Coordinator
675 W. Peachtree Street
Rm. 17H53

Atlanta, Georgia 30375

- 9.6 Conformance to recommendations made by BellSouth's fire insurance company. Heritage must conform to recommendations made by BellSouth's fire insurance company to the extent BellSouth has agreed to, or shall hereafter agree to, such recommendations.
- 9.7 Self-Insurance. If Heritage's net worth exceeds five hundred million dollars (\$500,000,000), Heritage may elect to request self-insurance status in lieu of obtaining any of the insurance required in Sections 9.2.1 and Section 9.2.3. Heritage shall provide audited financial statements to BellSouth thirty (30) days prior to the commencement of any work in the Remote Collocation Space. BellSouth shall then review such audited financial statements and respond in writing to Heritage in the event that self-insurance status is not granted to Heritage. If BellSouth approves Heritage for self-insurance, Heritage shall annually furnish to BellSouth, and keep current, evidence of such net worth that is attested to by one of Heritage's corporate officers. The ability to self-insure shall continue so long as Heritage meets all of the requirements of this Section. If Heritage subsequently no longer satisfies this Section, Heritage is required to purchase insurance as indicated by Sections 9.2.1 and Section 9.2.3.
- 9.8 Net worth requirements. The net worth requirements set forth in Section 9.7 may be increased by BellSouth from time to time during the term of this Attachment upon thirty (30) days' notice to Heritage to at least such minimum limits as shall then be customary with respect to comparable occupancy of BellSouth structures.
- 9.9 Failure to comply. Failure to comply with the provisions of this Section will be deemed a material breach of this Attachment.
10. **Mechanics Liens**
- 10.1 Mechanics Lien or other Liens. If any mechanics lien or other liens shall be filed against property of either Party (BellSouth or Heritage), or any improvement thereon by reason of or arising out of any labor or materials furnished or alleged to have been furnished or to be furnished to or for the other Party or by reason of any changes, or additions to said property made at the request or under the direction of the other Party, the other Party directing or requesting those changes shall, within thirty (30) business days after receipt of written notice from the Party against whose property said lien has been filed, either pay such lien or cause the same to be bonded off the affected property in the manner provided by law. The Party causing said lien to be placed against the property of the other shall also defend, at its sole cost and expense, on behalf of the other, any action, suit or proceeding which may be brought for the enforcement of such liens and shall pay any damage and discharge any judgment entered thereon.

11. Inspections

- 11.1 BellSouth may conduct inspection. BellSouth may conduct an inspection of Heritage's equipment and facilities in the Remote Collocation Space(s) prior to the activation of facilities between Heritage's equipment and equipment of BellSouth. BellSouth may conduct an inspection if Heritage adds equipment and may otherwise conduct routine inspections at reasonable intervals mutually agreed upon by the Parties. BellSouth shall provide Heritage with a minimum of forty-eight (48) hours or two (2) business days, whichever is greater, advance notice of all such inspections. All costs of such inspection shall be borne by BellSouth.

12. Security and Safety Requirements

- 12.1 Heritage will be required, at its own expense, to conduct a statewide investigation of criminal history records for each Heritage employee being considered for work on the BellSouth Premises, for the states/counties where the Heritage employee has worked and lived for the past five years. Where state law does not permit statewide collection or reporting, an investigation of the applicable counties is acceptable. Heritage shall not be required to perform this investigation if an affiliated company of Heritage has performed an investigation of the Heritage employee seeking access, if such investigation meets the criteria set forth above. This requirement will not apply if Heritage has performed a pre-employment statewide investigation of criminal history records of the Heritage employee for the states/counties where the Heritage employee has worked and lived for the past five years or, where state law does not permit a statewide investigation, an investigation of the applicable counties.
- 12.2 Heritage shall provide its employees and agents with picture identification which must be worn and visible at all times while in the Collocation Space or other areas in or around the Premises. The photo Identification card shall bear, at a **minimum**, the employee's name and photo, and the Heritage name. BellSouth reserves the right to remove from its premises any employee of Heritage not possessing identification issued by Heritage or who have violated any of BellSouth's policies as outlined in the CLEC Security Training documents. Heritage shall hold BellSouth harmless for any damages resulting from such removal of its personnel from BellSouth premises. Heritage shall be solely responsible for ensuring that any Guest of Heritage is in compliance with all subsections of this Section 12.
- 12.3 Heritage will be required to administer to their personnel assigned to the BellSouth Premises security training either provided by BellSouth, or meeting criteria defined by BellSouth.
- 12.4 Heritage shall not assign to the BellSouth Premises any personnel with records of felony criminal convictions. Heritage shall not assign to the BellSouth Premises any personnel with records of misdemeanor convictions, except for misdemeanor traffic

violations, without advising BellSouth of the nature and gravity of the offense(s). BellSouth reserves the right to refuse access to any Heritage personnel who have been identified to have misdemeanor criminal convictions. Notwithstanding the foregoing, in the event that Heritage chooses not to advise BellSouth of the nature and gravity of any misdemeanor conviction, Heritage may, in the alternative, certify to BellSouth that it shall not assign to the BellSouth Premises any personnel with records of misdemeanor convictions (other than misdemeanor traffic violations).

- 12.4.1 Heritage shall not knowingly assign to the BellSouth Premises any individual who was a former employee of BellSouth and whose employment with BellSouth was terminated for a criminal offense whether or not BellSouth sought prosecution of the individual for the criminal offense.
- 12.4.2 Heritage shall not knowingly assign to the BellSouth Premises any individual who was a former contractor of BellSouth and whose access to a BellSouth Premises was revoked due to commission of a criminal offense whether or not BellSouth sought prosecution of the individual for the criminal offense.
- 12.5 For each Heritage employee requiring access to a BellSouth Premises pursuant to this Attachment, Heritage shall furnish BellSouth, prior to an employee gaining such access, a certification that the aforementioned background check and security training were completed. The certification will contain a statement that no felony convictions were found and certifying that the security training was completed by the employee. If the employee's criminal history includes misdemeanor convictions, Heritage will disclose the nature of the convictions to BellSouth at that time. In the alternative, Heritage may certify to BellSouth that it shall not assign to the BellSouth Premises any personnel with records of misdemeanor convictions other than misdemeanor traffic violations.
- 12.6 At BellSouth's request, Heritage shall promptly remove from BellSouth's Premises any employee of Heritage BellSouth does not wish to grant access to its premises 1) pursuant to any investigation conducted by BellSouth or 2) prior to the initiation of an investigation if an employee of Heritage is found interfering with the property or personnel of BellSouth or another CLEC, provided that an investigation shall promptly be commenced by BellSouth.
- 12.7 Notification to BellSouth. BellSouth reserves the right to interview Heritage's employees, agents, or contractors in the event of wrongdoing in or around BellSouth's property or involving BellSouth's or another CLEC's property or personnel, provided that BellSouth shall provide reasonable notice to Heritage's Security contact of such interview. Heritage and its contractors shall reasonably cooperate with BellSouth's investigation into allegations of wrongdoing or criminal conduct committed by, witnessed by, or involving Heritage's employees, agents, or contractors. Additionally, BellSouth reserves the right to bill Heritage for all reasonable costs associated with investigations involving its employees, agents, or contractors if it is established and

mutually agreed in good faith that Heritage's employees, agents, or contractors are responsible for the alleged act. BellSouth shall bill Heritage for BellSouth property which is stolen or damaged where an investigation determines the culpability of Heritage's employees, agents, or contractors and where Heritage agrees, in good faith, with the results of such investigation. Heritage shall notify BellSouth in writing immediately in the event that the Heritage discovers one of its employees already working on the BellSouth premises is a possible security risk. Upon request of the other Party, the Party who is the employer shall discipline consistent with its employment practices, up to and including removal from BellSouth Premises, any employee found to have violated the security and safety requirements of this section. Heritage shall hold BellSouth harmless for any damages resulting from such removal of its personnel from BellSouth premises.

- 12.8 Use of Supplies. Unauthorized use of telecommunications equipment or supplies by either Party, whether or not used routinely to provide telephone service (e.g. plug-in cards,) will be strictly prohibited and handled appropriately. Costs associated with such unauthorized use may be charged to the offending Party, as may be all associated investigative costs.
- 12.9 Use of Official Lines. Except for non-toll calls necessary in the performance of their work, neither Party shall use the telephones of the other Party on the BellSouth Premises. Charges for unauthorized telephone calls may be charged to the offending Party, as may be all associated investigative costs. In no event shall Heritage, its agents, vendors or employees access BellSouth or any other CLEC's end user telephone lines.
- 12.10 Accountability. Full compliance with the Security requirements of this section shall in no way limit the accountability of either Party to the other for the improper actions of its employees.

13. Destruction of Remote Collocation Space

- 13.1 Remote Collocation Space is damaged. In the event a Remote Collocation Space is wholly or partially damaged by fire, windstorm, tornado, flood or by similar causes to such an extent as to be rendered wholly unsuitable for Heritage's permitted use hereunder, then either Party may elect within ten (10) business days after such damage, to terminate this Attachment with respect to the affected Remote Collocation Space, and if either Party shall so elect, by giving the other written notice of termination, both Parties shall stand released of and from further liability under the terms hereof with respect to such Remote Collocation Space. If the Remote Collocation Space shall suffer only minor damage and shall not be rendered wholly unsuitable for Heritage's permitted use, or is damaged and the option to terminate is not exercised by either Party, BellSouth covenants and agrees to proceed promptly without expense to Heritage, except for improvements not the property of BellSouth, to repair the

damage. BellSouth shall have a reasonable time within which to rebuild or make any repairs, and such rebuilding and repairing shall be subject to delays caused by storms, shortages of labor and materials, government regulations, strikes, walkouts, and causes beyond the control of BellSouth, which causes shall not be construed as limiting factors, but as exemplary only. Heritage may, at its own expense, accelerate the rebuild of its Remote Collocation Space and equipment provided however that a BellSouth Certified Contractor is used and the necessary space preparation has been completed. Rebuild of equipment must be performed by a BellSouth Certified Vendor. If Heritage's acceleration of the project increases the cost of the project, then those additional charges will be incurred by Heritage. Where allowed and where practical, Heritage may erect a temporary facility while BellSouth rebuilds or makes repairs. In all cases where the Remote Collocation Space shall be rebuilt or repaired, Heritage shall be entitled to an equitable abatement of rent and other charges, depending upon the unsuitability of the Remote Collocation Space for Heritage's permitted use, until such Remote Collocation Space is fully repaired and restored and Heritage's equipment installed therein (but in no event later than thirty (30) business days after the Remote Collocation Space is fully repaired and restored). Where Heritage has placed a Remote Site Adjacent Arrangement pursuant to section 3.4, Heritage shall have the sole responsibility to repair or replace said Remote Site Adjacent Arrangement provided herein. Pursuant to this section, BellSouth will restore the associated services to the Remote Site Adjacent Arrangement.

14. Eminent Domain

- 14.1 **Power of Eminent Domain.** If the whole of a Remote Collocation Space or Remote Site Adjacent Arrangement shall be taken by any public authority under the power of eminent domain, then this Attachment shall terminate with respect to such Remote Collocation Space or Remote Site Adjacent Arrangement as of the day possession shall be taken by such public authority and rent and other charges for the Remote Collocation Space or Remote Site Adjacent Arrangement shall be paid up to that day with proportionate refund by BellSouth of such rent and charges as may have been paid in advance for a period subsequent to the date of the taking. If any part of the Remote Collocation Space or Remote Site Adjacent Arrangement shall be taken under eminent domain, BellSouth and Heritage shall each have the right to terminate this Attachment with respect to such Remote Collocation Space or Remote Site Adjacent Arrangement and declare the same null and void, by written notice of such intention to the other Party within ten (10) business days after such taking.

15. Nonexclusivity

- 15.1 **Attachment is not exclusive.** Heritage understands that this Attachment is not exclusive and that BellSouth may enter into similar agreements with other Parties. Assignment of space pursuant to all such agreements shall be determined by space availability and made on a first come, first served basis.

ENVIRONMENTAL AND SAFETY PRINCIPLES

The following principles provide basic guidance on environmental and safety issues when applying for and establishing Physical Collocation arrangements.

1. GENERAL PRINCIPLES

- 1.1 **Compliance with Applicable Law.** BellSouth and Heritage agree to comply with applicable federal, state, and local environmental and safety laws and regulations including U.S. Environmental Protection Agency (USEPA) regulations issued under the Clean Air Act (CAA), Clean Water Act (CWA), Resource Conservation and Recovery Act (RCRA), Comprehensive Environmental Response, Compensation and Liability Act (CERCLA), Superfund Amendments and Reauthorization Act (SARA), the Toxic Substances Control Act (TSCA), and OSHA regulations issued under the Occupational Safety and Health Act of 1970, as amended and NFPA and National Electrical Codes (NEC) and the NESC ("Applicable Laws"). Each Party shall notify the other if compliance inspections are conducted by regulatory agencies and/or citations are issued that relate to any aspect of this Attachment.
- 1.2 **Notice.** BellSouth and Heritage shall provide notice to the other, including Material Safety Data Sheets (MSDSs), of known and recognized physical hazards or Hazardous Chemicals existing on site or brought on site. Each Party is required to provide specific notice for known potential Imminent Danger conditions. Heritage should contact 1-800-743-6737 for BellSouth MSDS sheets.
- 1.3 **Practices/Procedures.** BellSouth may make available additional environmental control procedures for Heritage to follow when working at a BellSouth Premises (See Section 2, below). These practices/procedures will represent the regular work practices required to be followed by the employees and contractors of BellSouth for environmental protection. Heritage will require its contractors, agents and others accessing the BellSouth Premises to comply with these practices. Section 2 lists the Environmental categories where BST practices should be followed by Heritage when operating in the BellSouth Premises.
- 1.4 **Environmental and Safety Inspections.** BellSouth reserves the right to inspect the Heritage space with proper notification. BellSouth reserves the right to stop any Heritage work operation that imposes Imminent Danger to the environment, employees or other persons in the area or Facility.
- 1.5 **Hazardous Materials Brought On Site.** Any hazardous materials brought into, used, stored or abandoned at the BellSouth Premises by Heritage are owned by Heritage. Heritage will indemnify BellSouth for claims, lawsuits or damages to persons or

property caused by these materials. Without prior written BellSouth approval, no substantial new safety or environmental hazards can be created by Heritage or different hazardous materials used by Heritage at BellSouth Facility. Heritage must demonstrate adequate emergency response capabilities for its materials used or remaining at the BellSouth Facility.

- 1.6 Spills and Releases. When contamination is discovered at a BellSouth Premises, the Party discovering the condition must notify BellSouth. All Spills or Releases of regulated materials will immediately be reported by Heritage to BellSouth.
- 1.7 Coordinated Environmental Plans and Permits. BellSouth and Heritage will coordinate plans, permits or information required to be submitted to government agencies, such as emergency response plans, spill prevention control and countermeasures (SPCC) plans and community reporting. If fees are associated with filing, BellSouth and Heritage will develop a cost sharing procedure. If BellSouth's permit or EPA identification number must be used, Heritage must comply with all of BellSouth's permit conditions and environmental processes, including environmental "best management practices (BMP)" (see Section 2, below) and/or selection of BST disposition vendors and disposal sites.
- 1.8 Environmental and Safety Indemnification. BellSouth and Heritage shall indemnify, defend and hold harmless the other Party from and against any claims (including, without limitation, third-party claims for personal injury or death or real or personal property damage), judgments, damages, (including direct and indirect damages, and punitive damages), penalties, fines, forfeitures, costs, liabilities, interest and losses arising in connection with the violation or alleged violation of any Applicable Law or contractual obligation or the presence or alleged presence of contamination arising out of the acts or omissions of the indemnifying Party, its agents, contractors, or employees concerning its operations at the Facility.

2. **CATEGORIES FOR CONSIDERATION OF ENVIRONMENTAL ISSUES**

When performing functions that fall under the following Environmental categories on BellSouth's Premises, Heritage agrees to comply with the applicable sections of the current issue of BellSouth's Environmental and Safety Methods and Procedures (M&Ps), incorporated herein by this reference. Heritage further agrees to cooperate with BellSouth to ensure that Heritage's employees, agents, and/or subcontractors are knowledgeable of and satisfy those provisions of BellSouth's Environmental M&Ps which apply to the specific Environmental function being performed by Heritage, its employees, agents and/or subcontractors.

The most current version of reference documentation must be requested from BellSouth.

ENVIRONMENTAL CATEGORIES	ENVIRONMENTAL ISSUES	ADDRESSED BY THE FOLLOWING DOCUMENTATION
Disposal of hazardous material or other regulated material (e.g., batteries, fluorescent tubes, solvents & cleaning materials)	<p>Compliance with all applicable local, state, & federal laws and regulations</p> <p>Pollution liability insurance</p> <p>EVET approval of contractor</p>	<ul style="list-style-type: none"> • Std T&C 450 • Fact Sheet Series 17000 • Std T&C 660-3 • Approved Environmental Vendor List (Contact E/S Management)
Emergency response	Hazmat/waste release/spill firesafety emergency	<ul style="list-style-type: none"> • Fact Sheet Series 1700 • Building Emergency Operations Plan (EOP) (specific to and located on Premises)
Contract labor/outsourcing for services with environmental implications to be performed on BellSouth Premises (e.g., disposition of hazardous material/waste; maintenance of storage tanks)	<p>Compliance with all applicable local, state, & federal laws and regulations</p> <p>Performance of services in accordance with BST's environmental M&Ps</p> <p>Insurance</p>	<ul style="list-style-type: none"> • Std T&C 450 • Std T&C 450-B • (Contact E/S for copy of appropriate E/S M&Ps.) • Std T&C 660
Transportation of hazardous material	<p>Compliance with all applicable local, state, & federal laws and regulations</p> <p>Pollution liability insurance</p> <p>EVET approval of contractor</p>	<ul style="list-style-type: none"> • Std T&C 450 • Fact Sheet Series 17000 • Std T&C 660-3 • Approved Environmental Vendor List (Contact E/S Management)
<p>Maintenance/operations work which may produce a waste</p> <p>Other maintenance work</p>	<p>Compliance with all application local, state, & federal laws and regulations</p> <p>Protection of BST employees and equipment</p>	<ul style="list-style-type: none"> • Std T&C 450 • 29CFR 1910.147 (OSHA Standard) • 29CFR 1910 Subpart O (OSHA Standard)

<p>Janitorial services</p>	<p>All waste removal and disposal must conform to all applicable federal, state and local regulations</p> <p>All Hazardous Material and Waste</p> <p>Asbestos notification and protection of employees and equipment</p>	<ul style="list-style-type: none"> • P&SM Manager - Procurement • Fact Sheet Series 17000 • GU-BTEN-001BT, Chapter 3 • BSP 010-170-001BS (Hazcom)
<p>Manhole cleaning</p>	<p>Compliance with all applicable local, state, & federal laws and regulations</p> <p>Pollution liability insurance</p> <p>EVET approval of contractor</p>	<ul style="list-style-type: none"> • Std T&C 450 • Fact Sheet 14050 • BSP 620-145-011PR Issue A, August 1996 • Std T&C 660-3 • Approved Environmental Vendor List (Contact E/S Management)
<p>Removing or disturbing building materials that may contain asbestos</p>	<p>Asbestos work practices</p>	<ul style="list-style-type: none"> • GU-BTEN-001BT, Chapter 3

3. DEFINITIONS

Generator. Under RCRA, the person whose act produces a Hazardous Waste, as defined in 40 CFR 261, or whose act first causes a Hazardous Waste to become subject to regulation. The Generator is legally responsible for the proper management and disposal of Hazardous Wastes in accordance with regulations.

Hazardous Chemical. As defined in the U.S. Occupational Safety and Health (OSHA) hazard communication standard (29 CFR 1910.1200), any chemical which is a health hazard or physical hazard.

Hazardous Waste. As defined in section 1004 of RCRA.

Imminent Danger. Any conditions or practices at a facility which are such that a danger exists which could reasonably be expected to cause immediate death or serious harm to people or immediate significant damage to the environment or natural resources.

Spill or Release. As defined in Section 101 of CERCLA.

4. ACRONYMS

E/S – Environmental/Safety

EVET - Environmental Vendor Evaluation Team

DEC/LDEC - Department Environmental Coordinator/Local Department Environmental Coordinator

GU-BTEN-001BT - BellSouth Environmental Methods and Procedures

NESC - National Electrical Safety Codes

P&SM - Property & Services Management

Std. T&C - Standard Terms & Conditions

Interval Matrix

State	Type	Space Availability/Bona Fide Firm Order	Application Response/Price Quote	Construction and Provisioning	
				Ordinary	Extraordinary
Alabama ¹	Cageless	10 Calendar Days	23 Business Days	60 Cal	90 Cal
Florida	Cageless	15 Calendar Days	15 Calendar Days*	90 Cal	NA
Georgia	Cageless	10 Calendar Days	30 Calendar Days	60 Cal	90 Cal
Kentucky ¹	Cageless	10 Calendar Days	23 Business Days	76 Bus.	91 Bus
Louisiana	Cageless	10 Calendar Days*	30 Calendar Days*	90 Cal	120 Cal
Mississippi	Cageless	10 Business Days	30 Business Days*	120 Cal	180Cal
North Carolina ¹	Cageless	10 Calendar Days	23 Business Days	76 Bus.	91 Bus
South Carolina	Cageless	10 Calendar Days	30 Calendar Days*	90 Cal	NA Cal
Tennessee ¹	Cageless	10 Calendar Days	23 Business Days	76 Bus.	91 Bus

* Extended intervals shall apply when multiple applications are submitted.

Note 1: The intervals were set by the FCC's Order in Docket No. 98-147 released February 20, 2001.

The construction and provisioning intervals, as listed for these states, will apply if a forecast is submitted three (3) months prior to the application date. Extended intervals shall apply if the forecast is not received three (3) months in advance.

THREE MONTH CLEC FORECAST

CLEC NAME _____

DATE _____

STATE	Central Office/City	CAGED Sq. Ft.	CAGELESS # Bays		FRAME TERMINATIONS	CLEC Provided BDFB—Amps Load	BST Provided BDFB—Amps Load	Heat Dissipation BTU/Hour	Entrance Facilities # sheaths & # fibers	Proposed Application Date	NOTES
			Standard Bays*	Non- Standard Bays**							

*Standard bays are defined as racks, bays or cabinets, including equipment and cable, with measurements equal to or less than the following: Width - 26", Depth - 25". The standard height for all collocated equipment bays in BellSouth is 7' 0".

** Any forecast for non-standard cageless bays must include an attachment describing the quantity and width and depth measurements.

Notes: Forecast information will be used for no other purpose than collocation planning.
Forecast with application dates greater than 3 months from the date of submission will not guarantee the reservation of space in the office requested.

COLLOCATION
Attachment 4
FLORIDA

CATEGORY	NOTE	RATE ELEMENT	Market Subsector	Zone	BCB	UBOC	RATES					OSS RATES					
							Nonrecurring			Recurring		See Order Submitted Rate per LSR	See Order Submitted Monthly per LSR	Incremental Charge - Based See Order vs. Electronic-Id	Incremental Charge - Based See Order vs. (Electronic-Id+Ad7)	Incremental Charge - Based See Order vs. (Electronic-Id+Ad7)	Incremental Charge - Based See Order vs. (Electronic-Id+Ad7)
							Flat	Per Sq. Ft.	Ad7	Flat	Ad7						
PHYSICAL COLLOCATION																	
		Physical Collocation - Application Fee - Initial			CLO	PEIBA											
		Physical Collocation - Application Fee - Subsequent			CLO	PEICA	\$3,791.00										
		Physical Collocation - Space Preparation - Firm Order Processing			CLO	PEISJ	\$3,160.00										
		Physical Collocation - Space Preparation - C.O. Modification per square ft.			CLO	PEISK	\$1,211.00										
		Physical Collocation - Space Preparation - Common Systems Modification per square ft. - Cables			CLO	PEISL	\$2.58										
		Physical Collocation - Space Preparation - Common Systems Modification per Cage			CLO	PEISM	\$2.98										
		Physical Collocation - Cable Installation			CLO	PEIBD	\$100.88										
		Physical Collocation - Floor Space per Sq. Ft.			CLO	PEIPJ	\$1,828.00										
		Physical Collocation - Cable Support Structure			CLO	PEIPM	\$6.57										
		Physical Collocation - Power per Fixed Amp			CLO	PEIPL	\$21.88										
		Physical Collocation - 120V, Single Phase Standby Power Rate			CLO	PEIFB	\$9.88										
		Physical Collocation - 240V, Single Phase Standby Power Rate			CLO	PEIFD	\$11.28										
		Physical Collocation - 120V, Three Phase Standby Power Rate			CLO	PEIFE	\$16.88										
		Physical Collocation - 277V, Three Phase Standby Power Rate			CLO	PEIFG	\$38.98										
					UEAN,UEAU,UDN,UDC,UALU,HLU,CL,UEQ												
		Physical Collocation - 2-Wire Cross-Connects			CLO	PEIP2	\$0.074	\$34.53									
		Physical Collocation - 4-Wire Cross-Connects			CLO	PEIP4	\$0.148	\$69.06									
		Physical Collocation - DS1 Cross-Connects			CLO	PEIP1	\$1.29	\$54.15									
		Physical Collocation - DS3 Cross-Connects			CLO	PEIP3	\$17.48	\$83.28									
		Physical Collocation - 2-Fiber Cross-Connect			CLO	PEIF2	\$2.98	\$53.28									
		Physical Collocation - 4-Fiber Cross-Connect			CLO	PEIF4	\$5.98	\$106.56									
		Physical Collocation - Welded Wire Cage - First 100 Sq. Ft.			CLO	PEIBW	\$205.93										
		Physical Collocation - Welded Wire Cage - Add'l 90 Sq. Ft.			CLO	PEICW	\$20.20										
		Physical Collocation - Security System Per Central Office Per Assignable Sq. Ft.			CLO	PEIAX	\$0.0113										
		Physical Collocation - Security Access System - New Access Card Activation, per Card			CLO	PEIA1	\$0.08	\$56.03									
		Physical Collocation - Security Access System - Administrative Change, existing Access Card, per Card			CLO	PEIAA	\$15.71										
		Physical Collocation - Security Access System - Replace Lost or Stolen Card, per Card			CLO	PEIAR	\$45.93										
		Physical Collocation - Security Access - Initial Key, per Key			CLO	PEIAK	\$26.41										
		Physical Collocation - Security Access - Key, Replace Lost or Stolen Key, per Key			CLO	PEIAL	\$26.41										
		Physical Collocation - Space Availability Report per premises			CLO	PEISR	\$2,168.00										
		Collocation Cable Records - per request *			CLO	PEICR	\$1,709.00										
		Collocation Cable Records - VG/DS0 Cable, per cable record *			CLO	PRICD	\$923.86										
		Collocation Cable Records - VG/DS0 Cable, per each 100 pair *			CLO	PEICD	\$18.03										
		Collocation Cable Records - DS1, per T1TIE *			CLO	PEIC1	\$8.44										
		Collocation Cable Records - DS3, per T3TIE *			CLO	PEIC3	\$29.54										
		Collocation Cable Records - Fiber Cable, per cable record *			CLO	PEICB	\$279.05										
		Physical Collocation - Security Escort - Basic, Per Quarter Hour			CLO	PEIBQ	\$10.89										
		Physical Collocation - Security Escort - Overtime, Per Quarter Hour			CLO	PEIOQ	\$13.64										
		Physical Collocation - Security Escort - Premium, Per Quarter Hour			CLO	PEIPQ	\$16.40										
ADJACENT COLLOCATION																	
		Adjacent Collocation - Space Charge per Sq. Ft.			CLO	PEIAA	\$0.182										
		Adjacent Collocation - Electrical Facility Charge per Linear Ft.			CLO	PEIJC	\$8.70										
		Adjacent Collocation - 2-Wire Cross-Connects			CLO	PEIP2	\$0.074	\$34.53									

**COLLOCATION
Attachment 4
FLORIDA**

CATEGORY	NOTE	RATE ELEMENT	Interim Indicator	Zone	ICS	USOC	RATES						OSB RATES					
							Nonreciprocal			Reciprocal			See Order Submitted Rate per LSP	See Order Submitted Monthly per LSP	Incremental Charge - Shared See Order vs. Electronics-1st	Incremental Charge - Shared See Order vs. Electronics-Add'l	Incremental Charge - Shared See Order vs. Electronics-1st	Incremental Charge - Shared See Order vs. Electronics-Add'l
							Res	First	Add'l	First	Add'l	See Order Submitted Rate per LSP						
		Adjacent Collocation - 4-Wire Cross-Connects			UEA,UHL,UDDL	PE1P4	\$0.148	\$34.54	\$32.53									
		Adjacent Collocation - DS1 Cross-Connects			UCL,CLO	PE1P1	\$1.29	\$4.15	\$40.94									
		Adjacent Collocation - DS3 Cross-Connects			CLO	PE1P3	\$17.49	\$53.28	\$39.65									
		Adjacent Collocation - 8-Fiber Cross-Connect			CLO	PE1F2	\$2.06	\$53.28	\$39.65									
		Adjacent Collocation - 4-Fiber Cross-Connect			CLO	PE1F4	\$5.65	\$95.09	\$52.47									
		Adjacent Collocation - Application Fee			CLO	PE1UB		\$2,677.00										
		Adjacent Collocation - 120V, Single Phase Standby Power Rate per AC Breaker Amp			CLO	PE1FB	\$5.82											
		Adjacent Collocation - 240V, Single Phase Standby Power Rate per AC Breaker Amp			CLO	PE1FD	\$11.26											
		Adjacent Collocation - 120V, Three Phase Standby Power Rate per AC Breaker Amp			CLO	PE1FE	\$18.98											
		Adjacent Collocation - 277V, Three Phase Standby Power Rate per AC Breaker Amp			CLO	PE1FG	\$38.98											
PHYSICAL COLLOCATION IN THE REMOTE SITE																		
		Physical Collocation in the Remote Site - Application Fee *			CLO	PE1RA		\$874.14	\$874.14									
		Cabinet Space in the Remote Site per Rack Foot			CLO	PE1RB	\$232.50											
		Physical Collocation in the Remote Site - Security Access - Key			CLO	PE1RD		\$26.20	\$26.20									
		Physical Collocation in the Remote Site - Space Availability, Report per Request Requested *			CLO	PE1SR		\$231.45	\$231.45									
		Physical Collocation in the Remote Site - Remote Site CLLI Code Request, per CLLI Code Requested *			CLO	PE1RE		\$75.13	\$75.13									
* Interim rates which are subject to true-up.																		
NOTE: If Security Escort and/or Add'l Engineering Fees become necessary for remote site collocation, the Parties will negotiate appropriate rates.																		

ATTACHMENT 5
ACCESS TO NUMBERS AND NUMBER PORTABILITY

TABLE OF CONTENTS

1. NON-DISCRIMINATORY ACCESS TO TELEPHONE NUMBERS.....3

2. NUMBER PORTABILITY PERMANENT SOLUTION.....3

3. SERVICE PROVIDER NUMBER PORTABILITY4

4. SPNP IMPLEMENTATION5

5. OPERATIONAL SUPPORT SYSTEM (OSS) RATES12

Rates.....Exhibit A

ACCESS TO NUMBERS AND NUMBER PORTABILITY

1. NON-DISCRIMINATORY ACCESS TO TELEPHONE NUMBERS

- 1.1 During the term of this Agreement, where Heritage is utilizing its own switch, Heritage shall contact the North American Numbering Plan Administrator, Neustar, for the assignment of numbering resources. In order to be assigned a Central Office Code, Heritage will be required to complete the Central Office Code (NXX) Assignment Request and Confirmation Form (Code Request Form) in accordance with Industry Numbering Committee's Central Office Code (NXX) Assignment Guidelines (INC 95-0407-008).
- 1.2 Where BellSouth is providing local switching, Heritage may utilize BellSouth's telephone numbers. BellSouth will provide Heritage with on line access to telephone numbers on a first come first served basis. Assignment, reservation and use of telephone numbers shall be governed by applicable FCC rules and regulations.
- 1.3 Heritage acknowledges that there may be instances where there is a shortage of telephone numbers in a particular Common Language Location Identifier Code (CLLIC); and in such instances, Heritage shall return numbers to BellSouth upon BellSouth's request. BellSouth shall make all such requests on a nondiscriminatory basis.

2. NUMBER PORTABILITY PERMANENT SOLUTION

- 2.1 The Parties will offer local number portability in accordance with rules, regulations and guidelines adopted by the Commission, the FCC and industry fora. Interim Service Provider Number Portability (SPNP) will be available only in those end offices where no carrier has requested implementation of permanent local number portability (PNP). Once PNP is implemented in an end office pursuant to the request of a carrier, both Parties must withdraw their SPNP offerings. The transition from existing SPNP arrangements to PNP shall occur within ninety (90) days from the date PNP is implemented in the end office. Neither Party shall charge the other Party for conversion from SPNP to PNP.
- 2.2 End User Line Charge. Where Heritage subscribes to BellSouth's local switching, BellSouth shall bill and Heritage shall pay the end user line charge associated with implementing PNP as set forth in BellSouth's FCC Tariff No. 1. This charge is not subject to the resale discount set forth in Attachment 1 of this Agreement.
- 2.3 To limit service outage, BellSouth and Heritage will adhere to the process flows and cutover guidelines for porting numbers as outlined in the LNP Reference Guide, as amended from time to time. The LNP Reference Guide, incorporated

herein by reference, is accessible via the Internet at the following site:
<http://www.interconnection.bellsouth.com>. All intervals referenced in the LNP Reference Guide shall apply to both BellSouth and Heritage.

- 2.4 The Parties will set Local Routing Number (LRN) unconditional or 10-digit triggers where applicable. Where triggers are set, the porting Party will remove the ported number at the same time the trigger is removed.
- 2.5 A trigger order is a service order issued in advance of the porting of a number. A trigger order 1) initiates call queries to the AIN SS7 network in advance of the number being ported; and 2) provides for the new service provider to be in control of when a number ports.
- 2.6 Where triggers are not set, the Parties shall coordinate the porting of the number between service providers so as to minimize service interruptions to the end user.
- 2.7 BellSouth and Heritage will work cooperatively to implement changes to PNP process flows ordered by the FCC or as recommended by standard industry forums addressing PNP.

3. SERVICE PROVIDER NUMBER PORTABILITY

- 3.1 Where PNP has not been implemented in an end office, the Parties shall provide SPNP. SPNP is a service arrangement whereby an end user who switches subscription of his local exchange service from BellSouth to a CLEC, or vice versa, is permitted to retain the use of his existing assigned telephone number, provided that the end user remains at the same location for his local exchange service or changes locations and service providers but stays within the same BellSouth local calling area of his existing number. Except as otherwise expressly provided herein, SPNP is available only where the local exchange carrier is currently providing basic local exchange service to the end user. SPNP for a particular assigned telephone number will be disconnected when any end user, Commission, BellSouth, or CLEC initiated activity (e.g., a change in exchange boundaries) would normally result in a telephone number change had the end user retained his initial local exchange service.
- 3.2 **Methods of Providing SPNP.** SPNP is available through either remote call forwarding or direct inward dialing trunks. Remote call forwarding (SPNP-RCF) is an existing switch-based service that redirects calls within the telephone network. Direct inward dialing trunks (SPNP-DID) allow calls to be routed over a dedicated facility to the switch that serves the subscriber.
- 3.3 **Signaling Requirements.** SS7 Signaling is required for the provision of SPNP services.
- 3.4 **Rates**

- 3.4.1 Rates for SPNP are set out in Exhibit A to this Attachment. If no rate is identified in the Attachment, the rate for the specific service or function will be as set forth in applicable BellSouth tariff or as negotiated by the Parties upon request by either Party.

4. SPNP IMPLEMENTATION

- 4.1 SPNP-RCF is a telecommunications service whereby a call dialed to an SPNP-RCF equipped telephone number is automatically forwarded to an assigned seven- or ten- digit telephone number within the local calling area as defined in BellSouth's General Subscriber Services Tariff. The forwarded-to number shall be specified by Heritage or BellSouth, as appropriate. The forwarding Party will provide identification of the originating telephone number, via SS7 signaling, to the receiving Party. Identification of the originating telephone number to the SPNP-RCF end user cannot be guaranteed, however. SPNP-RCF provides a single call path for the forwarding of no more than one call to the receiving Party's specified forwarded-to number. Additional call paths for the forwarding of multiple simultaneous calls are available on a per path basis at rates as outlined in this Attachment.
- 4.2 SPNP-DID service provides trunk side access to end office switches for direct inward dialing to the other Party's premises equipment from the telecommunications network to lines associated with the other Party's switching equipment and must be provided on all trunks in a group arranged for inward service. SPNP-DID is available from BellSouth on a per DS0, DS1 or DS3 basis. A SPNP-DID trunk termination charge, provided with SS7 Signaling only, applies for each trunk voice grade equivalent. In addition, direct facilities are required from the end office where a ported number resides to the end office serving the ported end user customer. The rates for a switched local channel and switched dedicated transport apply as contained in BellSouth's Intrastate Access Services tariff, as amended from time to time. Transport mileage will be calculated as the airline distance between the end office where the number is ported and the Point of Interface ("POI") using the V&H coordinate method. SPNP-DID must be established with a minimum configuration of two channels and one unassigned telephone number per switch, per arrangement for control purposes. Transport facilities arranged for SPNP-DID may not be mixed with any other type of trunk group, with no outgoing calls placed over said facilities. SPNP-DID will be provided only where such facilities are available and where the switching equipment of the ordering Party is properly equipped. Where SPNP-DID service is required from more than one wire center or from separate trunk groups within the same wire center, such service provided from each wire center or each trunk group within the same wire center shall be considered a separate service. Only customer-dialed sent-paid calls will be completed to the first number of a SPNP-DID number group; however, there are no restrictions on calls completed to other

numbers of a SPNP-DID number group. Sent-paid calls refer to those calls placed by an end user who physically deposits currency in a public telephone. Interface group arrangements provided for terminating the switched transport at the Party's terminal location are as set forth in of BellSouth's Intrastate Access Services Tariff, § E6.1.3.A as amended from time to time.

- 4.3 SPNP-DID Service requires ordering consecutive telephone numbers in blocks of twenty. Heritage may order non-consecutive telephone numbers or telephone numbers in less than blocks of twenty pursuant to BellSouth's tariffs.
- 4.4 The calling Party shall be responsible for payment of the applicable charges for sent-paid calls to the SPNP number. For collect, third-party, or other operator-assisted non-sent paid calls to the ported telephone number, BellSouth or Heritage shall be responsible for the payment of charges under the same terms and conditions for which the end user would have been liable for those charges. Either Party may request that the other block collect and third party non-sent paid calls to the SPNP-assigned telephone number. If a Party does not request blocking, the other Party will provide itemized local usage detail for the billing of non-sent paid calls on the monthly bill of usage charges provided at the individual end user account level. The detail will include itemization of all billable usage. Each Party shall have the option of receiving this usage data on a daily basis via a data file transfer arrangement. This arrangement will utilize the existing industry uniform standard, known as EMI standards, for exchange of billing data. Files of usage data will be created daily for the optional service. Usage originated and recorded in the sending BellSouth RAO will be provided in unrated or rated format, depending on processing system. Heritage usage originated elsewhere and delivered via CMDS to the sending BellSouth RAO shall be provided in rated format.
- 4.5 The new service provider shall be responsible for obtaining authorization from the end user for the handling of the disconnection of the end user's service, the provision of new local service and the provision of SPNP services. Each Party shall be responsible for coordinating the provision of service with the other to assure that its switch is capable of accepting SPNP ported traffic. Each Party shall be solely responsible to ensure that its facilities, equipment and services do not interfere with or impair any facility, equipment, or service of the other Party or any of its end users. In the event that either Party determines in its reasonable judgment that the other Party will likely impair or is impairing, or interfering with any equipment, facility or service or any of its end users, that Party may either refuse to provide SPNP service or may terminate SPNP service to the other Party after providing appropriate notice.
- 4.6 Each Party shall be responsible for providing an appropriate intercept announcement service for any telephone numbers subscribed to SPNP-DID services for which it is not presently providing local exchange service or terminating to an end user. Where either Party chooses to disconnect or terminate any SPNP service, that Party shall be responsible for designating the preferred standard type of announcement to be provided.

- 4.7 End-to-end transmission characteristics may vary depending on the distance and routing necessary to complete calls over SPNP facilities and the fact that another carrier is involved in the provisioning of service. Neither Party shall specify end-to-end transmission characteristics for SPNP calls.
- 4.8 Where SPNP-RCF is utilized for SPNP, for terminating IXC traffic ported to either Party which requires use of either Party's tandem switching, the tandem provider will bill the IXC tandem switching, the interconnection charge, and a portion of the transport, and the other Party will bill the IXC local switching, the carrier common line and a portion of the transport. If the tandem provider is unable to provide the necessary access records to permit the other Party to bill the IXC directly for terminating access to ported numbers, then the tandem provider will bill the IXC full terminating switched access charges at the tandem provider's rate and will compensate the other Party at the tandem Party's tariff rates via a process used by BellSouth to estimate the amount of ported switched access revenues due the other Party. If an intraLATA toll call is delivered, the delivering Party will pay terminating access rates to the other Party.

5. OPERATIONAL SUPPORT SYSTEM (OSS) RATES

- 5.1 The terms, conditions and rates for OSS are as set forth in Attachment 2.

**SERVICE PROVIDER NUMBER PORTABILITY
Florida**

CATEGORY	NOTES	UNBUNDLED NETWORK ELEMENT	Area Indicator	Zone	ICS	USOC	RATES				OSS RATES					
							Nonrecurring		Disconnect		Svc Order Submitted Esc per LSR	Svc Order Submitted Monthly per LSR	Incremental Charge - Manual Svc Order vs. Electronic-1st	Incremental Charge - Manual Svc Order vs. Electronic-Add1	Incremental Charge - Manual Svc Order vs. Electronic-Disc 1st	Incremental Charge - Manual Svc Order vs. Electronic-Disc Add1
							Rec	First	Add1	First						
							Rec	First	Add1	First	Add1	\$OMEC	\$OMAN	\$OCAN	\$OMAN	\$OMAN
INTERIM SERVICE PROVIDER NUMBER PORTABILITY - RCF																
		RCF, per number ported (Business Line)				TNPBL	\$1.97	\$0.3738	\$0.3738	\$0.0374	\$0.0374	\$3.50	\$10.73			\$1.65
		RCF, per number ported (Residence Line)				TNPPIL	\$1.97	\$0.3738	\$0.3738	\$0.0374	\$0.0374	\$3.50	\$10.73			\$1.65
		RCF, Per Additional Path					\$0.6878									
INTERIM SERVICE PROVIDER NUMBER PORTABILITY - DID																
		DID per number ported (Residence)				TNPDR		\$0.6242	\$0.6242	\$0.6242	\$0.6242	\$3.50	\$10.73			\$1.65
		DID per number ported (Business)				TNPDB		\$0.6242	\$0.6242	\$0.6242	\$0.6242	\$3.50	\$10.73			\$1.65
		DID, per trunk termination, Initial				TNPT2	\$52.73	\$145.42	\$145.42	\$29.51	\$29.51	\$3.50	\$10.73			\$1.65
		DID, per trunk termination, Subsequent				TNPT2	\$52.73	\$72.65	\$72.65	\$29.51	\$29.51	\$3.50	\$10.73			\$1.65
SERVICE PROVIDER NUMBER PORTABILITY (RIPH)																
		RIPH, Functionally, Per Reorganization						\$18.11	\$18.11			\$10.73				\$1.65
		RIPH, Per Number Ported					\$1.75	\$0.1952	\$0.1952	\$0.0195	\$0.0195	\$10.73				\$1.65
		RIPH, Functionally, Per Central Ofc						\$81.56	\$81.56	\$2.29	\$2.29	\$10.73				\$1.65
Note: If no rate is identified in the contract, the rate for the specific service or function will be as set forth in applicable BellSouth tariff or as negotiated by the Parties upon request by either Party.																

Attachment 6
Pre-Ordering, Ordering and Provisioning,
Maintenance and Repair

TABLE OF CONTENTS

1. QUALITY OF PRE-ORDERING, ORDERING AND PROVISIONING, MAINTENANCE AND REPAIR.....3

2. ACCESS TO OPERATIONS SUPPORT SYSTEMS.....3

3. MISCELLANEOUS ORDERING AND PROVISIONING GUIDELINES.....5

PRE-ORDERING, ORDERING AND PROVISIONING, MAINTENANCE AND REPAIR

1. QUALITY OF PRE-ORDERING, ORDERING AND PROVISIONING, MAINTENANCE AND REPAIR

1.1 BellSouth shall provide pre-ordering, ordering and provisioning and maintenance and repair services to Heritage that are equivalent to the pre-ordering, ordering and provisioning and maintenance and repair services BellSouth provides to itself or any other CLEC, where technically feasible. The guidelines for pre-ordering, ordering and provisioning and maintenance and repair are set forth in the various guides and business rules, as appropriate, and as they are amended from time to time during this Agreement. The guides and business rules are found at <http://www.interconnection.bellsouth.com> and are incorporated herein by reference.

1.2 For purposes of this Agreement, BellSouth's regular working hours for provisioning are defined as follows:

Monday – Friday – 8:00 a.m. – 5:00 p.m. (Excluding Holidays)
 (Resale/UNE non-coordinated,
 coordinated orders and order
 coordinated-time specific)
 Saturday - 8:00 a.m. – 5:00 p.m. (Excluding Holidays)
 (Resale/UNE non-coordinated
 orders)

1.2.1 The above hours represent the hours, either Eastern or Central Time, of where the physical work is being performed.

1.2.2 To the extent Heritage requests provisioning of service to be performed outside BellSouth's regular working hours, or the work so requested requires BellSouth's technicians to work outside regular working hours, overtime billing charges shall apply. Notwithstanding the foregoing, if such work is performed outside of regular working hours by a BellSouth technician during his or her scheduled shift and BellSouth does not incur any overtime charges in performing the work on behalf of Heritage, BellSouth will not assess Heritage additional charges beyond the rates and charges specified in this Agreement.

2. ACCESS TO OPERATIONS SUPPORT SYSTEMS

2.1 BellSouth shall provide Heritage access to operations support systems ("OSS") functions for pre-ordering, ordering and provisioning, maintenance and repair, and billing. BellSouth shall provide access to the OSS through manual and/or electronic interfaces as described in this Attachment. It is the sole responsibility of Heritage to obtain the technical capability to access and utilize BellSouth's OSS

interfaces. Specifications for Heritage's access and use of BellSouth's electronic interfaces are set forth at www.interconnection.bellsouth.com and are incorporated herein by reference.

- 2.1.1 **Pre-Ordering.** In accordance with FCC and Commission rules and orders, BellSouth will provide electronic access to the following pre-ordering functions: service address validation, telephone number selection, service and feature availability, due date information, customer record information and loop makeup information. Access is provided through the Local Exchange Navigation System (LENS) interface and the Telecommunications Access Gateway (TAG) interface. Customer record information includes customer specific information in CRIS and RSAG. Heritage shall not view, copy, or otherwise obtain access to the customer record information of any customer without that customer's permission. Heritage will obtain access to customer record information only in strict compliance with applicable laws, rules, or regulations of the State in which the service is provided. BellSouth reserves the right to audit Heritage's access to customer record information. If a BellSouth audit of Heritage's access to customer record information reveals that Heritage is accessing customer record information without having obtained the proper End User authorization, BellSouth upon reasonable notice to Heritage may take corrective action, including but not limited to suspending or terminating Heritage's electronic access to BellSouth's OSS functionality. All such information obtained through an audit shall be deemed Information covered by the Proprietary and Confidential Information section in the General Terms and Conditions of this Agreement.
- 2.1.2 **Service Ordering.** BellSouth will make available the Electronic Data Interchange (EDI) interface and the TAG ordering interface for the purpose of exchanging order information, including order status and completion notification, for non-complex and certain complex resale requests and certain network elements. Heritage may integrate the EDI interface or the TAG ordering interface with the TAG pre-ordering interface. In addition, BellSouth will provide integrated pre-ordering and ordering capability through the LENS interface for non-complex and certain complex resale service requests and certain network element requests.
- 2.1.3 **Maintenance and Repair.** Heritage may report and monitor service troubles and obtain repair services from BellSouth via electronic interfaces. BellSouth provides several options for electronic trouble reporting. For exchange services, BellSouth will offer Heritage non-discriminatory access to the Trouble Analysis Facilitation Interface (TAFI). In addition, BellSouth will offer an industry standard, machine-to-machine Electronic Communications Trouble Administration (ECTA) Gateway interface. For designed services, BellSouth will provide non-discriminatory trouble reporting via the ECTA Gateway. BellSouth will provide Heritage an estimated time to repair, an appointment time or a commitment time, as appropriate, on trouble reports. Requests for trouble repair will be billed in accordance with the provisions of this Attachment. BellSouth and Heritage agree to adhere to BellSouth's Operational Understanding, as amended from time to time during this Agreement and as incorporated herein by reference. The Operational

Understanding may be accessed via the Internet at <http://www.interconnection.bellsouth.com>.

- 2.2 **Change Management.** BellSouth provides a collaborative process for change management of the electronic interfaces through the Change Control Process (CCP). Guidelines for this process are set forth in the CCP document as amended from time to time during this Agreement. The CCP document may be accessed via the Internet at <http://www.interconnection.bellsouth.com>.
- 2.3 **BellSouth's Versioning Policy for Electronic Interfaces.** BellSouth's Versioning Policy is part of the Change Control Process (CCP). Pursuant to the CCP, BellSouth will issue new software releases for new industry standards for its EDI and TAG electronic interfaces. The Versioning Policy, including the appropriate notification to Heritage, is set forth in the CCP document as amended from time to time during this Agreement. The CCP document may be accessed via the Internet at <http://www.interconnection.bellsouth.com>.
- 2.4 **Rates.** Charges for use of OSS shall be as set forth in Attachments 1 and 2 of this Agreement and are incorporated herein by reference.
3. **MISCELLANEOUS**
- 3.1 **Pending Orders.** Orders placed in the hold or pending status by Heritage will be held for a maximum of thirty (30) days from the date the order is placed on hold. After such time, Heritage shall be required to submit a new service order. Incorrect or invalid orders returned to Heritage for correction or clarification will be held for ten (10) days. If Heritage does not return a corrected order within ten (10) days, BellSouth will cancel the order.
- 3.2 **Single Point of Contact.** Heritage will be the single point of contact with BellSouth for ordering activity for network elements and other services used by Heritage to provide services to its end users, except that BellSouth may accept an order directly from another CLEC, or BellSouth, acting with authorization of the affected end user. Heritage and BellSouth shall each execute a blanket letter of authorization with respect to customer orders. The Parties shall each be entitled to adopt their own internal processes for verification of customer authorization for orders, provided, however, that such processes shall comply with applicable state and federal law including, until superseded, the FCC guidelines and orders applicable to Presubscribed Interexchange Carrier (PIC) changes, including Un-PIC. Pursuant to an order from another carrier, BellSouth may disconnect any network element being used by Heritage to provide service to that end user and may reuse such network elements or facilities to enable such other carrier to provide service to the end user. BellSouth will notify Heritage that such an order has been processed, but will not be required to notify Heritage in advance of such processing.

- 3.3 **Use of Facilities.** When a customer of Heritage elects to discontinue service and transfer service to another local exchange carrier, including BellSouth, BellSouth shall have the right to reuse the facilities provided to CLEC by BellSouth. In addition, where BellSouth provides local switching, BellSouth may disconnect and reuse facilities when the facility is in a denied state and BellSouth has received an order to establish new service or transfer of service from a customer or a customer's CLEC at the same address served by the denied facility. BellSouth will notify Heritage that such an order has been processed after the disconnect order has been completed.
- 3.4 **Contact Numbers.** The Parties agree to provide one another with toll-free nationwide (50 states) contact numbers for the purpose of ordering, provisioning and maintenance of services.
- 3.5 **Subscription Functions.** In cases where BellSouth performs subscription functions for an inter-exchange carrier (i.e. PIC and LPIC changes via Customer Account Record Exchange (CARE)), BellSouth will provide the affected inter-exchange carriers with the Operating Company Number (OCN) of the local provider for the purpose of obtaining end user billing account and other end user information required under subscription requirements.
- 3.6 **Cancellation Charges.** If Heritage cancels an order for Network Elements or other services, any costs incurred by BellSouth in conjunction with the provisioning of that order will be recovered in accordance with FCC No. 1 Tariff, Section 5.
- 3.7 **Expedite Charges.** For expedited requests by Heritage, expedited charges will apply for intervals less than the standard interval as outlined in the BellSouth Product and Services Interval Guide. The charges as outlined in BellSouth's FCC No. 1 Tariff, Section 5, will apply.
- 3.8 **CLEC Responsibilities.** Heritage shall provide to BellSouth electronic access to customer record information, where available. If electronic access is not available, Heritage shall provide paper copies of customer record information. Such information shall be provided to BellSouth in the same intervals that BellSouth provides such information to Heritage.

Attachment 7

Billing

TABLE OF CONTENTS

1. Payment and Billing Arrangements..... 3

2. Billing Disputes 6

3. RAO Hosting..... 7

4. Optional Daily Usage File..... 10

5. Access Daily Usage File..... 13

Rates.....Exhibit A

BILLING

1. PAYMENT AND BILLING ARRANGEMENTS

All negotiated rates, terms and conditions set forth in this Attachment pertain to billing and billing accuracy certifications.

- 1.1 **Billing.** BellSouth agrees to provide billing through the Carrier Access Billing System (CABS) and through the Customer Records Information System (CRIS) depending on the particular service(s) that Heritage requests. BellSouth will bill and record in accordance with this Agreement those charges Heritage incurs as a result of Heritage purchasing from BellSouth Network Elements and Other Services as set forth in this Agreement. BellSouth will format all bills in CBOS Standard or CLUB/EDI format, depending on the type of service ordered. For those services where standards have not yet been developed, BellSouth's billing format will change as necessary when standards are finalized by the industry forum.
- 1.1.1 For any service(s) BellSouth orders from Heritage, Heritage shall bill BellSouth in CABS format.
- 1.1.2 If either Party requests multiple billing media or additional copies of bills, the Billing Party will provide these at a reasonable cost.
- 1.2 **Master Account.** After receiving certification as a local exchange company from the appropriate regulatory agency, Heritage will provide the appropriate BellSouth account manager the necessary documentation to enable BellSouth to establish a master account for Local Interconnection, Network Elements and Other Services, and/or resold services. Such documentation shall include the Application for Master Account, proof of authority to provide telecommunications services, an Operating Company Number (OCN) assigned by the National Exchange Carriers Association (NECA), Carrier Identification Code (CIC), Group Access Code (GAC), Access Customer Name and Abbreviation (ACNA) and a tax exemption certificate, if applicable.
- 1.2.1 **Payment Responsibility.** Payment of all charges will be the responsibility of Heritage. Heritage shall make payment to BellSouth for all services billed. BellSouth is not responsible for payments not received by Heritage from Heritage's customer. BellSouth will not become involved in billing disputes that may arise between Heritage and Heritage's customer. Payments made to BellSouth as payment on account will be credited to an accounts receivable master account and not to an end user's account.
- 1.3 **Payment Due.** The payment will be due on or before the next bill date (i.e., same date in the following month as the bill date) and is payable in immediately available funds. Payment is considered to have been made when received by BellSouth.

- 1.4 If the payment due date falls on a Sunday or on a Holiday which is observed on a Monday, the payment due date shall be the first non-Holiday day following such Sunday or Holiday. If the payment due date falls on a Saturday or on a Holiday which is observed on Tuesday, Wednesday, Thursday, or Friday, the payment due date shall be the last non-Holiday day preceding such Saturday or Holiday. If payment is not received by the payment due date, a late payment charge, as set forth in Section 1.6, below, shall apply.
- 1.5 Tax Exemption. Upon proof of tax exempt certification from Heritage, the total amount billed to Heritage will not include those taxes or fees for which the CLEC is exempt. Heritage will be solely responsible for the computation, tracking, reporting and payment of all taxes and like fees associated with the services provided to the end user of Heritage.
- 1.6 Late Payment. If any portion of the payment is received by BellSouth after the payment due date as set forth preceding, or if any portion of the payment is received by BellSouth in funds that are not immediately available to BellSouth, then a late payment charge shall be due to BellSouth. The late payment charge shall be the portion of the payment not received by the payment due date times a late factor and will be applied on a per bill basis. The late factor shall be as set forth in Section A2 of the General Subscriber Services Tariff, Section B2 of the Private Line Service Tariff or Section E2 of the Intrastate Access Tariff, whichever BellSouth determines is appropriate. Heritage will be charged a fee for all returned checks as set forth in Section A2 of the General Subscriber Services Tariff or pursuant to the applicable state law.
- 1.7 Discontinuing Service to Heritage. The procedures for discontinuing service to Heritage are as follows:
- 1.7.1 BellSouth reserves the right to suspend or terminate service for nonpayment of services or in the event of prohibited, unlawful or improper use of BellSouth facilities or service or any other violation or noncompliance by Heritage of the rules and regulations contained in BellSouth's tariffs.
- 1.7.2 If payment of amounts not subject to a billing dispute, as described in Section 2, is not received by the bill date in the month after the original bill date, BellSouth may provide written notice to Heritage that additional applications for service will be refused and that any pending orders for service will not be completed if payment is not received by the fifteenth day following the date of the notice. In addition, BellSouth may, at the same time, give thirty (30) days notice to Heritage at the billing address to discontinue the provision of existing services to Heritage at any time thereafter.
- 1.7.3 In the case of such discontinuance, all billed charges, as well as applicable termination charges, shall become due.

- 1.7.4 If BellSouth does not discontinue the provision of the services involved on the date specified in the thirty days notice and Heritage's noncompliance continues, nothing contained herein shall preclude BellSouth's right to discontinue the provision of the services to Heritage without further notice.
- 1.7.5 If payment is not received or satisfactory arrangements made for payment by the date given in the written notification, Heritage's services will be discontinued. Upon discontinuance of service on Heritage's account, service to Heritage's end users will be denied. BellSouth will reestablish service at the request of the end user or Heritage for BellSouth to reestablish service upon payment of the appropriate connection fee and subject to BellSouth's normal application procedures. Heritage is solely responsible for notifying the end user of the proposed service disconnection. If within fifteen (15) days after an end user's service has been denied and no arrangements to reestablish service have been made consistent with this subsection, the end user's service will be disconnected.
- 1.8 Deposit Policy. When purchasing services from BellSouth, Heritage will be required to complete the BellSouth Credit Profile and provide information regarding credit worthiness. Based on the results of the credit analysis, BellSouth reserves the right to secure the account with a suitable form of security deposit. Such security deposit shall take the form of cash, an Irrevocable Letter of Credit (BellSouth form), Surety Bond (BellSouth form) or, in its sole discretion, some other form of security. Any such security deposit shall in no way release Heritage from its obligation to make complete and timely payments of its bill. Such security shall be required prior to the inauguration of service. If, in the sole opinion of BellSouth, circumstances so warrant and/or gross monthly billing has increased beyond the level initially used to determine the level of security, BellSouth reserves the right to request additional security and/or file a Uniform Commercial Code (UCC1) security interest in Heritage's "accounts receivables and proceeds." Interest on a security deposit, if provided in cash, shall accrue and be paid in accordance with the terms in the appropriate BellSouth tariff. Security deposits collected under this Section shall not exceed two months' estimated billing. In the event Heritage fails to remit to BellSouth any deposit requested pursuant to this Section, service to Heritage may be terminated in accordance with the terms of Section 1.7 of this Attachment, and any security deposits will be applied to Heritage's account(s).
- 1.9 Notices. Notwithstanding anything to the contrary in this Agreement, all bills and notices regarding billing matters, including notices relating to security deposits, to rejection of additional orders from Heritage and to disconnection of services for nonpayment of charges, shall be forwarded to the individual and/or address provided by Heritage in establishment of its billing account(s) with BellSouth, or to the individual and/or address subsequently provided by Heritage as the contact for billing information. All monthly bills and notices described in this Section shall be forwarded to the same individual and/or address; provided, however, upon written notice from Heritage to BellSouth's billing organization, a final notice of

disconnection of services purchased by Heritage under this Agreement shall be sent via certified mail to the individual(s) listed in the Notices provision of the General Terms and Conditions of this Agreement at least 30 days before BellSouth takes any action to terminate such services.

- 1.10 Rates. Rates for Optional Daily Usage File (ODUF), Access Daily Usage File (ADUF), and Centralized Message Distribution Service (CMDS) are set out in Exhibit A to this Attachment. If no rate is identified in this Attachment, the rate for the specific service or function will be as set forth in applicable BellSouth tariff or as negotiated by the Parties upon request by either Party.

2. BILLING DISPUTES

- 2.1 Billing disputes shall be handled pursuant to the terms of this section.

- 2.1.1 Each Party agrees to notify the other Party in writing upon the discovery of a billing dispute. In the event of a billing dispute, the Parties will endeavor to resolve the dispute within sixty (60) calendar days of the notification date. If the Parties are unable within the 60 day period to reach resolution, then the aggrieved Party may pursue dispute resolution in accordance with the General Terms and Conditions of this Agreement.

- 2.1.2 For purposes of this Section 2, a billing dispute means a dispute of a specific amount of money actually billed by either Party. The dispute must be clearly explained by the disputing Party and supported by written documentation, which clearly shows the basis for disputing charges. By way of example and not by limitation, a billing dispute will not include the refusal to pay all or part of a bill or bills when no written documentation is provided to support the dispute, nor shall a billing dispute include the refusal to pay other amounts owed by the billed Party until the dispute is resolved. Claims by the billed Party for damages of any kind will not be considered a billing dispute for purposes of this Section. Once the billing dispute is resolved, the disputing Party will make immediate payment of any of the disputed amount owed to the billing Party or the billing Party shall have the right to pursue normal treatment procedures. Any credits due to the disputing Party, pursuant to the billing dispute, will be applied to the disputing Party's account by the billing Party immediately upon resolution of the dispute.

- 2.2 If a Party disputes a charge and does not pay such charge by the payment due date, or if a payment or any portion of a payment is received by either Party after the payment due date, or if a payment or any portion of a payment is received in funds which are not immediately available to the other Party, then a late payment charge shall be assessed. For bills rendered by either Party for payment, the late payment charge for both Parties shall be calculated based on the portion of the payment not received by the payment due date times the late factor as set forth in the following BellSouth tariffs: for services purchased from the General Subscribers Services Tariff for purposes of resale and for ports and non-designed loops, Section A2 of the General Subscriber Services Tariff; for services purchased from the Private

Line Tariff for purposes of resale, Section B2 of the Private Line Service Tariff; and for network elements and other services and local interconnection charges, Section E2 of the Access Service Tariff. In no event, however, shall interest be assessed by either Party on any previously assessed late payment charges. The Parties shall assess interest on previously assessed late payment charges only in a state where it has the authority pursuant to its tariffs.

3. RAO HOSTING

- 3.1 RAO Hosting, Calling Card and Third Number Settlement System (CATS) and Non-Intercompany Settlement System (NICS) services provided to Heritage by BellSouth will be in accordance with the methods and practices regularly adopted and applied by BellSouth to its own operations during the term of this Agreement, including such revisions as may be made from time to time by BellSouth.
- 3.2 Heritage shall furnish all relevant information required by BellSouth for the provision of RAO Hosting, CATS and NICS.
- 3.3 Compensation amounts, if applicable, will be billed by BellSouth to Heritage on a monthly basis in arrears. Amounts due from one Party to the other (excluding adjustments) are payable within thirty (30) days of receipt of the billing statement.
- 3.4 Heritage must have its own unique hosted RAO code. Requests for establishment of RAO status where BellSouth is the selected CMDS interfacing host, require written notification from Heritage to the BellSouth RAO Hosting coordinator at least eight (8) weeks prior to the proposed effective date. The proposed effective date will be mutually agreed upon between the Parties with consideration given to time necessary for the completion of required Telcordia (formerly BellCore) functions. BellSouth will request the assignment of an RAO code from its connecting contractor, currently Telcordia (formerly BellCore), on behalf of Heritage and will coordinate all associated conversion activities.
- 3.5 BellSouth will receive messages from Heritage that are to be processed by BellSouth, another LEC or CLEC in the BellSouth region or a LEC outside the BellSouth region.
- 3.6 BellSouth will perform invoice sequence checking, standard EMI format editing, and balancing of message data with the EMI trailer record counts on all data received from Heritage.
- 3.7 All data received from Heritage that is to be processed or billed by another LEC or CLEC within the BellSouth region will be distributed to that LEC or CLEC in accordance with the Agreement(s) which may be in effect between BellSouth and the involved LEC or CLEC.
- 3.8 All data received from Heritage that is to be placed on the CMDS network for distribution outside the BellSouth region will be handled in accordance with the

agreement(s) which may be in effect between BellSouth and its connecting contractor (currently Telcordia (formerly BellCore)).

- 3.9 BellSouth will receive messages from the CMDS network that are destined to be processed by Heritage and will forward them to Heritage on a daily basis.
- 3.10 Transmission of message data between BellSouth and Heritage will be via CONNECT:Direct.
- 3.11 All messages and related data exchanged between BellSouth and Heritage will be formatted in accordance with accepted industry standards for EMI formatted records and packed between appropriate EMI header and trailer records, also in accordance with accepted industry standards.
- 3.12 Heritage will ensure that the recorded message detail necessary to recreate files provided to BellSouth will be maintained for back-up purposes for a period of three (3) calendar months beyond the related message dates.
- 3.13 Should it become necessary for Heritage to send data to BellSouth more than sixty (60) days past the message date(s), Heritage will notify BellSouth in advance of the transmission of the data. If there will be impacts outside the BellSouth region, BellSouth will work with its connecting contractor and Heritage to notify all affected Parties.
- 3.14 In the event that data to be exchanged between the two Parties should become lost or destroyed, both Parties will work together to determine the source of the problem. Once the cause of the problem has been jointly determined and the responsible Party (BellSouth or Heritage) identified and agreed to, the company responsible for creating the data (BellSouth or Heritage) will make every effort to have the affected data restored and retransmitted. If the data cannot be retrieved, the responsible Party will be liable to the other Party for any resulting lost revenue. Lost revenue may be a combination of revenues that could not be billed to the end users and associated access revenues. Both Parties will work together to estimate the revenue amount based upon historical data through a method mutually agreed upon. The resulting estimated revenue loss will be paid by the responsible Party to the other Party within three (3) calendar months of the date of problem resolution, or as mutually agreed upon by the Parties.
- 3.15 Should an error be detected by the EMI format edits performed by BellSouth on data received from Heritage, the entire pack containing the affected data will not be processed by BellSouth. BellSouth will notify Heritage of the error condition. Heritage will correct the error(s) and will resend the entire pack to BellSouth for processing. In the event that an out-of-sequence condition occurs on subsequent packs, Heritage will resend these packs to BellSouth after the pack containing the error has been successfully reprocessed by BellSouth.

- 3.16 In association with message distribution service, BellSouth will provide Heritage with associated intercompany settlements reports (CATS and NICS) as appropriate.
- 3.17 In no case shall either Party be liable to the other for any direct or consequential damages incurred as a result of the obligations set out in this Agreement.
- 3.18 RAO Compensation
- 3.18.1 Rates for message distribution service provided by BellSouth for Heritage are as set forth in Exhibit A to this Attachment.
- 3.18.2 Rates for data transmission associated with message distribution service are as set forth in Exhibit A to this Attachment.
- 3.18.3 Data circuits (private line or dial-up) will be required between BellSouth and Heritage for the purpose of data transmission. Where a dedicated line is required, Heritage will be responsible for ordering the circuit, overseeing its installation and coordinating the installation with BellSouth. Heritage will also be responsible for any charges associated with this line. Equipment required on the BellSouth end to attach the line to the mainframe computer and to transmit successfully ongoing will be negotiated on a case by case basis. Where a dial-up facility is required, dial circuits will be installed in the BellSouth data center by BellSouth and the associated charges assessed to Heritage. Additionally, all message toll charges associated with the use of the dial circuit by Heritage will be the responsibility of Heritage. Associated equipment on the BellSouth end, including a modem, will be negotiated on a case by case basis between the Parties.
- 3.18.4 All equipment, including modems and software, that is required on the Heritage end for the purpose of data transmission will be the responsibility of Heritage.
- 3.19 Intercompany Settlements Messages
- 3.19.1 This Section addresses the settlement of revenues associated with traffic originated from or billed by Heritage as a facilities based provider of local exchange telecommunications services outside the BellSouth region. Only traffic that originates in one Bell operating territory and bills in another Bell operating territory is included. Traffic that originates and bills within the same Bell operating territory will be settled on a local basis between Heritage and the involved company(ies), unless that company is participating in NICS.
- 3.19.2 Both traffic that originates outside the BellSouth region by Heritage and is billed within the BellSouth region, and traffic that originates within the BellSouth region and is billed outside the BellSouth region by Heritage, is covered by this Agreement (CATS). Also covered is traffic that either is originated by or billed by Heritage, involves a company other than Heritage, qualifies for inclusion in the

CATS settlement, and is not originated or billed within the BellSouth region (NICS).

- 3.19.3 Once Heritage is operating within the BellSouth territory, revenues associated with calls originated and billed within the BellSouth region will be settled via Telcordia (formerly BellCore)'s, its successor or assign, NICS system.
- 3.19.4 BellSouth will receive the monthly NICS reports from Telcordia (formerly BellCore), its successor or assign, on behalf of Heritage. BellSouth will distribute copies of these reports to Heritage on a monthly basis.
- 3.19.5 BellSouth will receive the monthly Calling Card and Third Number Settlement System (CATS) reports from Telcordia (formerly BellCore), its successor or assign, on behalf of Heritage. BellSouth will distribute copies of these reports to Heritage on a monthly basis.
- 3.19.6 BellSouth will collect the revenue earned by Heritage from the Bell operating company in whose territory the messages are billed (CATS), less a per message billing and collection fee of five cents (\$0.05), on behalf of Heritage. BellSouth will remit the revenue billed by Heritage to the Bell operating company in whose territory the messages originated, less a per message billing and collection fee of five cents (\$0.05), on behalf on Heritage. These two amounts will be netted together by BellSouth and the resulting charge or credit issued to Heritage via a monthly Carrier Access Billing System (CABS) miscellaneous bill.
- 3.19.7 BellSouth will collect the revenue earned by Heritage within the BellSouth territory from another CLEC also within the BellSouth territory (NICS) where the messages are billed, less a per message billing and collection fee of five cents (\$0.05), on behalf of Heritage. BellSouth will remit the revenue billed by Heritage within the BellSouth region to the CLEC also within the BellSouth region, where the messages originated, less a per message billing and collection fee of five cents (\$0.05). These two amounts will be netted together by BellSouth and the resulting charge or credit issued to Heritage via a monthly CABS miscellaneous bill.
- 3.19.8 BellSouth and Heritage agree that monthly netted amounts of less than fifty dollars (\$50.00) will not be settled.

4. OPTIONAL DAILY USAGE FILE

- 4.1 Upon written request from Heritage, BellSouth will provide the Optional Daily Usage File (ODUF) service to Heritage pursuant to the terms and conditions set forth in this section.
- 4.2 Heritage shall furnish all relevant information required by BellSouth for the provision of the ODUF.

- 4.3 The Optional Daily Usage Feed will contain billable messages that were carried over the BellSouth Network and processed in the BellSouth Billing System, but billed to a Heritage customer.
- 4.4 Charges for delivery of the ODUF will appear on Heritages' monthly bills. The charges are as set forth in Exhibit A to this Attachment.
- 4.5 The Optional Daily Usage Feed will contain both rated and unrated messages. All messages will be in the standard Alliance for Telecommunications Industry Solutions (ATIS) EMI record format.
- 4.6 Messages that error in the billing system of Heritage will be the responsibility of Heritage. If, however, Heritage should encounter significant volumes of errored messages that prevent processing by Heritage within its systems, BellSouth will work with Heritage to determine the source of the errors and the appropriate resolution.
- 4.7 The following specifications shall apply to the Optional Daily Usage Feed.
- 4.7.1 **USAGE TO BE TRANSMITTED**
- 4.7.1.1 The following messages recorded by BellSouth will be transmitted to Heritage:
- Message recording for per use/per activation type services (examples: Three -Way Calling, Verify, Interrupt, Call Return, etc.)
 - Measured billable Local
 - Directory Assistance messages
 - IntraLATA Toll
 - WATS and 800 Service
 - N11
 - Information Service Provider Messages
 - Operator Services Messages
 - Operator Services Message Attempted Calls (Network Element only)
 - Credit/Cancel Records
 - Usage for Voice Mail Message Service
- 4.7.1.2 Rated Incollects (originated in BellSouth and from other companies) can also be on ODUF. Rated Incollects will be intermingled with BellSouth recorded rated and unrated usage. Rated Incollects will not be packed separately.

4.7.1.3 BellSouth will perform duplicate record checks on records processed to ODUF. Any duplicate messages detected will be deleted and not sent to Heritage.

4.7.1.4 In the event that Heritage detects a duplicate on ODUF they receive from BellSouth, Heritage will drop the duplicate message (Heritage will not return the duplicate to BellSouth).

4.7.2 **PHYSICAL FILE CHARACTERISTICS**

4.7.2.1 ODUF will be distributed to Heritage via an agreed medium with CONNECT:Direct being the preferred transport method. The Daily Usage Feed will be a variable block format (2476) with an LRECL of 2472. The data on the Daily Usage Feed will be in a non-compacted EMI format (175 byte format plus modules). It will be created on a daily basis (Monday through Friday except holidays). Details such as dataset name and delivery schedule will be addressed during negotiations of the distribution medium. There will be a maximum of one dataset per workday per OCN.

4.7.2.2 Data circuits (private line or dial-up) will be required between BellSouth and Heritage for the purpose of data transmission. Where a dedicated line is required, Heritage will be responsible for ordering the circuit, overseeing its installation and coordinating the installation with BellSouth. Heritage will also be responsible for any charges associated with this line. Equipment required on the BellSouth end to attach the line to the mainframe computer and to transmit successfully ongoing will be negotiated on a case by case basis. Where a dial-up facility is required, dial circuits will be installed in the BellSouth data center by BellSouth and the associated charges assessed to Heritage. Additionally, all message toll charges associated with the use of the dial circuit by Heritage will be the responsibility of Heritage. Associated equipment on the BellSouth end, including a modem, will be negotiated on a case by case basis between the Parties. All equipment, including modems and software, that is required on Heritage's end for the purpose of data transmission will be the responsibility of Heritage.

4.7.3 **PACKING SPECIFICATIONS**

4.7.3.1 A pack will contain a minimum of one message record or a maximum of 99,999 message records plus a pack header record and a pack trailer record. One transmission can contain a maximum of 99 packs and a minimum of one pack.

4.7.3.2 The OCN, From RAO, and Invoice Number will control the invoice sequencing. The From RAO will be used to identify to Heritage which BellSouth RAO that is sending the message. BellSouth and Heritage will use the invoice sequencing to control data exchange. BellSouth will be notified of sequence failures identified by Heritage and resend the data as appropriate.

The data will be packed using ATIS EMI records.

4.7.4 PACK REJECTION

4.7.4.1 Heritage will notify BellSouth within one business day of rejected packs (via the mutually agreed medium). Packs could be rejected because of pack sequencing discrepancies or a critical edit failure on the Pack Header or Pack Trailer records (i.e. out-of-balance condition on grand totals, invalid data populated). Standard ATIS EMI Error Codes will be used. Heritage will not be required to return the actual rejected data to BellSouth. Rejected packs will be corrected and retransmitted to Heritage by BellSouth.

4.7.5 CONTROL DATA

4.7.5.1 Heritage will send one confirmation record per pack that is received from BellSouth. This confirmation record will indicate Heritage received the pack and the acceptance or rejection of the pack. Pack Status Code(s) will be populated using standard ATIS EMI error codes for packs that were rejected by Heritage for reasons stated in the above section.

4.7.6 TESTING

4.7.6.1 Upon request from Heritage, BellSouth shall send test files to Heritage for ODUF. The Parties agree to review and discuss the file's content and/or format. For testing of usage results, BellSouth shall request that Heritage set up a production (LIVE) file. The live test may consist of Heritage's employees making test calls for the types of services Heritage requests on ODUF. These test calls are logged by Heritage, and the logs are provided to BellSouth. These logs will be used to verify the files. Testing will be completed within 30 calendar days from the date on which the initial test file was sent.

5. ACCESS DAILY USAGE FILE

5.1 Upon written request from Heritage, BellSouth will provide the Access Daily Usage File (ADUF) service to Heritage pursuant to the terms and conditions set forth in this section.

5.2 Heritage shall furnish all relevant information required by BellSouth for the provision of ADUF.

5.3 ADUF will contain access messages associated with a port that Heritage has purchased from BellSouth

5.4 Charges for delivery of ADUF will appear on Heritage's monthly bills. The charges are as set forth in Exhibit A to this Attachment. All messages will be in the standard ATIS EMI record format.

5.5 Messages that error in the billing system of Heritage will be the responsibility of Heritage. If, however, Heritage should encounter significant volumes of errored

messages that prevent processing by Heritage within its systems, BellSouth will work with Heritage to determine the source of the errors and the appropriate resolution.

5.6 USAGE TO BE TRANSMITTED

5.6.1 The following messages recorded by BellSouth will be transmitted to Heritage:

5.6.1.1 Recorded originating and terminating interstate and intrastate access records associated with a port.

5.6.1.2 Recorded terminating access records for undetermined jurisdiction access records associated with a port.

5.6.2 When Heritage purchases Network Element ports from BellSouth and calls are made using these ports, BellSouth will handle the calls as follows:

5.6.2.1 Originating from Network Element and carried by Interexchange Carrier:

5.6.2.1.1 BellSouth will bill network element to CLEC and send access record to the CLEC via ADUF.

5.6.2.2 Originating from network element and carried by BellSouth (Heritage is BellSouth's toll customer).

5.6.2.3 Terminating on network element and carried by Interexchange Carrier:

5.6.2.3.1 BellSouth will bill network element to Heritage and send access record to Heritage.

5.6.2.4 Terminating on network element and carried by BellSouth:

5.6.2.4.1 BellSouth will bill network element to Heritage and send access record to Heritage.

5.6.3 BellSouth will perform duplicate record checks on records processed to ADUF. Any duplicate messages detected will be dropped and not sent to Heritage.

5.6.4 In the event that Heritage detects a duplicate on ADUF they receive from BellSouth, Heritage will drop the duplicate message (Heritage will not return the duplicate to BellSouth.)

5.6.5 PHYSICAL FILE CHARACTERISTICS

5.6.5.1 ADUF will be distributed to Heritage via CONNECT:Direct. The Access Daily Usage Feed will be a fixed block format (2476) with an LRECL of 2472. The data on the Daily Usage Feed will be in a non-compacted EMI format (210 byte). It will be created on a daily basis (Monday through Friday except holidays). Details

such as dataset name and delivery schedule will be addressed during negotiations of the distribution medium. There will be a maximum of one dataset per workday per OCN.

- 5.6.5.2 Data circuits (private line or dial-up) will be required between BellSouth and Heritage for the purpose of data transmission. Where a dedicated line is required, Heritage will be responsible for ordering the circuit, overseeing its installation and coordinating the installation with BellSouth. Heritage will also be responsible for any charges associated with this line. Equipment required on the BellSouth end to attach the line to the mainframe computer and to transmit successfully ongoing will be negotiated on a case by case basis. Where a dial-up facility is required, dial circuits will be installed in the BellSouth data center by BellSouth and the associated charges assessed to Heritage. Additionally, all message toll charges associated with the use of the dial circuit by Heritage will be the responsibility of Heritage. Associated equipment on the BellSouth end, including a modem, will be negotiated on a case by case basis between the Parties. All equipment, including modems and software, that is required on Heritage's end for the purpose of data transmission will be the responsibility of Heritage.

5.6.6 **PACKING SPECIFICATIONS**

- 5.6.6.1 A pack will contain a minimum of one message record or a maximum of 99,999 message records plus a pack header record and a pack trailer record. One transmission can contain a maximum of 99 packs and a minimum of one pack.
- 5.6.6.2 The OCN, From RAO, and Invoice Number will control the invoice sequencing. The From RAO will be used to identify to Heritage which BellSouth RAO is sending the message. BellSouth and Heritage will use the invoice sequencing to control data exchange. BellSouth will be notified of sequence failures identified by Heritage and resend the data as appropriate.

The data will be packed using ATIS EMI records.

5.6.7 **PACK REJECTION**

- 5.6.7.1 Heritage will notify BellSouth within one business day of rejected packs (via the mutually agreed medium). Packs could be rejected because of pack sequencing discrepancies or a critical edit failure on the Pack Header or Pack Trailer records (i.e. out-of-balance condition on grand totals, invalid data populated). Standard ATIS EMI Error Codes will be used. Heritage will not be required to return the actual rejected data to BellSouth. Rejected packs will be corrected and retransmitted to Heritage by BellSouth.

5.6.8 **CONTROL DATA**

- 5.6.8.1 Heritage will send one confirmation record per pack that is received from BellSouth. This confirmation record will indicate Heritage received the pack and

the acceptance or rejection of the pack. Pack Status Code(s) will be populated using standard ATIS EMI error codes for packs that were rejected by Heritage for reasons stated in the above section.

5.6.9 Testing

5.6.9.1 Upon request from Heritage, BellSouth shall send a test file of generic data to Heritage via Connect:Direct or Text File via E-Mail. The Parties agree to review and discuss the test file's content and/or format.

CATEGORY	NOTES	UNBUNDLED NETWORK ELEMENT	Interin	Zrrv	BCS	USOC	RATES					OBS RATES												
							Measuring		Dissemination		Source	Per Order Submitted Rate per LBR	Per Order Submitted Monthly per LBR	Incremental Charge - Manual Order vs. Electronic-Adt	Incremental Charge - Manual Order vs. Electronic-Dis-Adt	Incremental Charge - Manual Order vs. Electronic-Dis-Adt	Incremental Charge - Manual Order vs. Electronic-Dis-Adt							
							Per	Adt	Per	Adt														
							Per	Adt	Per	Adt	Source	SC2DC	SC2SM	SC2SM	SC2SM	SC2SM	SC2SM							
ODUF/EDOUF/ADUF/CMS																								
ACCESS DAILY USAGE FILE (ADUF)																								
		ADUF: Message Processing, per message				N/A						\$0.0132280												
		ADUF: Data Transmission (CONNECT DIRECT), per message				N/A						\$0.000129270												
OPTIONAL DAILY USAGE FILE (ODUF)																								
		ODUF: Recording, per message				N/A						\$0.0000098												
		ODUF: Message Processing, per message				N/A						\$0.006614												
		ODUF: Message Processing, per Magnetic Tape provisioned				N/A						\$48.77												
		ODUF: Data Transmission (CONNECT DIRECT), per message				N/A						\$0.00010772												
CENTRALIZED MESSAGE DISTRIBUTION SERVICE (CMS)																								
		CMS: Message Processing, per message				N/A						\$0.001												
		CMS: Data Transmission (CONNECT DIRECT), per message				N/A						\$0.001												
Notes: If no rate is identified in the contract, the rate for the specific service or function will be as set forth in applicable BellSouth tariff or as negotiated by the Parties upon request by either Party.																								

Attachment 8

Rights-of-Way, Conduits and Pole Attachments

Rights-of-Way, Conduits and Pole Attachments

BellSouth will provide nondiscriminatory access to any pole, duct, conduit, or right-of-way owned or controlled by BellSouth pursuant to 47 U.S.C. § 224, as amended by the Act, pursuant to terms and conditions of a license agreement subsequently negotiated with BellSouth's Competitive Structure Provisioning Center.

ATTACHMENT 9

PERFORMANCE MEASUREMENTS

PERFORMANCE MEASUREMENTS

Upon a particular Commission's issuance of an Order pertaining to Performance Measurements in a proceeding expressly applicable to all CLECs generally, BellSouth shall implement in that state such Performance Measurements as of the date specified by the Commission.

AGREEMENT IMPLEMENTATION TEMPLATE (Residence)
for
Heritage Technologies, Ltd.
BellSouth Standard Interconnection Agreement

Agreement Effective Date: <effective_date>	Agreement Expiration Date: <expiration_date>
Account Manager:	Account Manager Tel No:

Attachment Name/Number	Section Number	Version Date	Planned Activities
Terms/Conditions	1		
	2		
	3		
	4		
	5		
	6		
	7		
	8		
	9		
	10		
	11		
	12		
	13		
	14		
	15		
	16		
	17		
	18		
	19		
	20		
	21		
	22		
	23		
	24		
	25		
	26		
	27		

AGREEMENT IMPLEMENTATION TEMPLATE (Residence)
for
Heritage Technologies, Ltd.
BellSouth Standard Interconnection Agreement

Attachment Name/Number	Section Number	Version Date	Planned Activities
	28		
	29		
	30		
	31		
	32		
	33		
	34		
1-Resale	1		
	2		
	3		
	4		
	5		
	6		
	7		
	8		
	9		
	10		
	11		
	12		
	Exhibit A		
	Exhibit B		
	Exhibit C		
	Exhibit D		
	Exhibit E		
	Exhibit F		
2-Network Elements & Other Svs	1		
	2		
	3		
	4		
	5		

AGREEMENT IMPLEMENTATION TEMPLATE (Residence)
for
Heritage Technologies, Ltd.
BellSouth Standard Interconnection Agreement

Attachment Name/Number	Section Number	Version Date	Planned Activities
	6		
	7		
	8		
	9		
	10		
	11		
	12		
	13		
	Exhibit A		
	Exhibit B		
	Exhibit C		
3-Local Interconnection	1		
	2		
	3		
	4		
	5		
	6		
	7		
	8		
	9		
	Exhibit A		
	Exhibit B		
	Exhibit C		
	Exhibit D		
	Exhibit E		
4-Physical Collocation	C.O.		
	TN		
	Rem Site		
5-Access to Numbers/Num Portability	1		
	2		

AGREEMENT IMPLEMENTATION TEMPLATE (Residence)
for
Heritage Technologies, Ltd.
BellSouth Standard Interconnection Agreement

Attachment Name/Number	Section Number	Version Date	Planned Activities
	3		
	4		
	5		
	Exhibit A		
6-Pre-Ordering, Ordering/ Provisioning/Maint/Repair	1		
	2		
	3		
7-Billing	1		
	2		
	3		
	4		
	5		
	Exhibit A		
8-ROW/Conduits/PoleAtt			
9-Perf Measurement			
10-Agrmt Implementation Template			
11-Disaster Recovery			
12-BFR/NBR Process			

AGREEMENT IMPLEMENTATION TEMPLATE (Business)
for
Heritage Technologies, Ltd.
BellSouth Standard Interconnection Agreement

Agreement Effective Date:	Agreement Expiration Date:
Account Manager:	Account Manager Tel No:

Attachment Name	Section No.	Version Date	Planned Activities
Terms/Conditions	1		
	2		
	3		
	4		
	5		
	6		
	7		
	8		
	9		
	10		
	11		
	12		
	13		
	14		
	15		
	16		
	17		
	18		
	19		
	20		
	21		
	22		
	23		
	24		
	25		
	26		
	27		

AGREEMENT IMPLEMENTATION TEMPLATE (Business)
for
Heritage Technologies, Ltd.
BellSouth Standard Interconnection Agreement

Attachment Name	Section No.	Version Date	Planned Activities
	28		
	29		
	30		
	31		
	32		
	33		
	34		
1-Resale	1		
	2		
	3		
	4		
	5		
	6		
	7		
	8		
	9		
	10		
	11		
	12		
	Exhibit A		
	Exhibit B		
	Exhibit C		
	Exhibit D		
	Exhibit E		
	Exhibit F		
2-Network Elements & Other Services	1		
	2		
	3		
	4		
	5		

AGREEMENT IMPLEMENTATION TEMPLATE (Business)
for
Heritage Technologies, Ltd.
BellSouth Standard Interconnection Agreement

Attachment Name	Section No.	Version Date	Planned Activities
	6		
	7		
	8		
	9		
	10		
	11		
	12		
	13		
	Exhibit A		
	Exhibit B		
	Exhibit C		
3-Local Interconnection	1		
	2		
	3		
	4		
	5		
	6		
	7		
	8		
	9		
	Exhibit A		
	Exhibit B		
	Exhibit C		
	Exhibit D		
	Exhibit E		
4-Physical Collocation	C.O.		
	TN		
	Rem Site		
5-Access to Numbers/Num Portability	1		
	2		

AGREEMENT IMPLEMENTATION TEMPLATE (Business)
for
Heritage Technologies, Ltd.
BellSouth Standard Interconnection Agreement

Attachment Name ¹	Section No.	Version Date	Planned Activities
	3		
	4		
	5		
	Exhibit A		
6-Pre-Ord/Ord/Prov/Maint/ Repair	1		
	2		
	3		
7-Billing	1		
	2		
	3		
	4		
	5		
	Exhibit A		
8-ROW/Conduits/PoleAtt			
9-Perf Measurement			
10-Agmt Implementation Template			
11-Disaster Recovery Plan			
12-BFR/NBR Process			

Attachment 11

BellSouth Disaster Recovery Plan

CONTENTS



PAGE

1.0	Purpose	2
2.0	Single Point of Contact	2
3.0	Identifying the Problem	2
3.1	Site Control	3
3.2	Environmental Concerns	4
4.0	The Emergency Control Center (ECC)	4
5.0	Recovery Procedures	5
5.1	CLEC Outage	5
5.2	BellSouth Outage	5
5.2.1	Loss of Central Office	6
5.2.2	Loss of a Central Office with Serving Wire Center Functions	6
5.2.3	Loss of a Central Office with Tandem Functions	6
5.2.4	Loss of a Facility Hub	6
5.3	Combined Outage (CLEC and BellSouth Equipment)	7
6.0	T1 Identification Procedures	7
7.0	Acronyms	8

1.0 PURPOSE

In the unlikely event of a disaster occurring that affects BellSouth's long-term ability to deliver traffic to a Competitive Local Exchange Carrier (CLEC), general procedures have been developed to hasten the recovery process. Since each location is different and could be affected by an assortment of potential problems, a detailed recovery plan is impractical. However, in the process of reviewing recovery activities for specific locations, some basic procedures emerge that appear to be common in most cases.

These general procedures should apply to any disaster that affects the delivery of traffic for an extended time period. Each CLEC will be given the same consideration during an outage and service will be restored as quickly as possible.

This document will cover the basic recovery procedures that would apply to every CLEC.

2.0 SINGLE POINT OF CONTACT

When a problem is experienced, regardless of the severity, the BellSouth Network Management Center (NMC) will observe traffic anomalies and begin monitoring the situation. Controls will be appropriately applied to insure the sanity of BellSouth's network; and, in the event that a switch or facility node is lost, the NMC will attempt to circumvent the failure using available reroutes.

BellSouth's NMC will remain in control of the restoration efforts until the problem has been identified as being a long-term outage. At that time, the NMC will contact BellSouth's Emergency Control Center (ECC) and relinquish control of the recovery efforts. Even though the ECC may take charge of the situation, the NMC will continue to monitor the circumstances and restore traffic as soon as damaged network elements are revitalized.

The telephone number for the BellSouth Network Management Center in Atlanta, as published in Telcordia's National Network Management Directory, is 404-321-2516.

3.0 IDENTIFYING THE PROBLEM

During the early stages of problem detection, the NMC will be able to tell which CLECs are affected by the catastrophe. Further analysis and/or first hand observation will determine if the disaster has affected CLEC equipment only; BellSouth equipment only or a combination. The initial restoration activity will be largely determined by the equipment that is affected.

Once the nature of the disaster is determined and after verifying the cause of the problem, the NMC will initiate reroutes and/or transfers that are jointly agreed upon by the affected CLECs' Network Management Center and the BellSouth NMC. The type and percentage of controls used will depend upon available network capacity. Controls necessary to stabilize the situation will be invoked and the NMC will attempt to re-establish as much traffic as possible.

For long term outages, recovery efforts will be coordinated by the Emergency Control Center (ECC). Traffic controls will continue to be applied by the NMC until facilities are re-established. As equipment is made available for service, the ECC will instruct the NMC to begin removing the controls and allow traffic to resume.

3.1 SITE CONTROL

In the total loss of building use scenario, what likely exists will be a smoking pile of rubble. This rubble will contain many components that could be dangerous. It could also contain any personnel on the premises at the time of the disaster. For these reasons, the local fire marshal with the assistance of the police will control the site until the building is no longer a threat to surrounding properties and the companies have secured the site from the general public.

During this time, the majority owner of the building should be arranging for a demolition contractor to mobilize to the site with the primary objective of reaching the cable entrance facility for a damage assessment. The results of this assessment would then dictate immediate plans for restoration, both short term and permanent.

In a less catastrophic event, i.e., the building is still standing and the cable entrance facility is usable, the situation is more complex. The site will initially be controlled by local authorities until the threat to adjacent property has diminished. Once the site is returned to the control of the companies, the following events should occur.

An initial assessment of the main building infrastructure systems (mechanical, electrical, fire and life safety, elevators, and others) will establish building needs. Once these needs are determined, the majority owner should lead the building restoration efforts. There may be situations where the site will not be totally restored within the confines of the building. The companies must individually determine their needs and jointly assess the cost of permanent restoration to determine the overall plan of action.

Multiple restoration trailers from each company will result in the need for designated space and installation order. This layout and control is required to maximize the amount of restoration equipment that can be placed at the site, and the priority of placements.

Care must be taken in this planning to insure other restoration efforts have logistical access to the building. Major components of telephone and building equipment will need to be removed and replaced. A priority for this equipment must also be jointly established to facilitate overall site restoration. (Example: If the AC switchgear has sustained damage, this would be of the highest priority in order to regain power, lighting, and HVAC throughout the building.)

If the site will not accommodate the required restoration equipment, the companies would then need to quickly arrange with local authorities for street closures, rights of way or other possible options available.

3.2 ENVIRONMENTAL CONCERNS

In the worse case scenario, many environmental concerns must be addressed. Along with the police and fire marshal, the state environmental protection department will be on site to monitor the situation.

Items to be concerned with in a large central office building could include:

1. Emergency engine fuel supply. Damage to the standby equipment and the fuel handling equipment could have created "spill" conditions that have to be handled within state and federal regulations.
2. Asbestos containing materials that may be spread throughout the wreckage. Asbestos could be in many components of building, electrical, mechanical, outside plant distribution, and telephone systems.
3. Lead and acid. These materials could be present in potentially large quantities depending upon the extent of damage to the power room.
4. Mercury and other regulated compounds resident in telephone equipment.
5. Other compounds produced by the fire or heat.

Once a total loss event occurs at a large site, local authorities will control immediate clean up (water placed on the wreckage by the fire department) and site access.

At some point, the companies will become involved with local authorities in the overall planning associated with site clean up and restoration. Depending on the clean up approach taken, delays in the restoration of several hours to several days may occur.

In a less severe disaster, items listed above are more defined and can be addressed individually depending on the damage.

In each case, the majority owner should coordinate building and environmental restoration as well as maintain proper planning and site control.

4.0 THE EMERGENCY CONTROL CENTER (ECC)

The ECC is located in the Colonnade Building in Birmingham, Alabama. During an emergency, the ECC staff will convene a group of pre-selected experts to inventory the damage and initiate corrective actions. These experts have regional access to BellSouth's personnel and equipment and will assume control of the restoration activity anywhere in the nine-state area.

In the past, the ECC has been involved with restoration activities resulting from hurricanes, ice storms and floods. They have demonstrated their capabilities during these calamities as well as

during outages caused by human error or equipment failures. This group has an excellent record of restoring service as quickly as possible.

During a major disaster, the ECC may move emergency equipment to the affected location, direct recovery efforts of local personnel and coordinate service restoration activities with the CLECs. The ECC will attempt to restore service as quickly as possible using whatever means is available; leaving permanent solutions, such as the replacement of damaged buildings or equipment, for local personnel to administer.

Part of the ECC's responsibility, after temporary equipment is in place, is to support the NMC efforts to return service to the CLECs. Once service has been restored, the ECC will return control of the network to normal operational organizations. Any long-term changes required after service is restored will be made in an orderly fashion and will be conducted as normal activity.

5.0 RECOVERY PROCEDURES

The nature and severity of any disaster will influence the recovery procedures. One crucial factor in determining how BellSouth will proceed with restoration is whether or not BellSouth's equipment is incapacitated. Regardless of who's equipment is out of service, BellSouth will move as quickly as possible to aid with service recovery; however, the approach that will be taken may differ depending upon the location of the problem.

5.1 CLEC OUTAGE

For a problem limited to one CLEC (or a building with multiple CLECs), BellSouth has several options available for restoring service quickly. For those CLECs that have agreements with other CLECs, BellSouth can immediately start directing traffic to a provisional CLEC for completion. This alternative is dependent upon BellSouth having concurrence from the affected CLECs.

Whether or not the affected CLECs have requested a traffic transfer to another CLEC will not impact BellSouth's resolve to re-establish traffic to the original destination as quickly as possible.

5.2 BELLSOUTH OUTAGE

Because BellSouth's equipment has varying degrees of impact on the service provided to the CLECs, restoring service from damaged BellSouth equipment is different. The outage will probably impact a number of Carriers simultaneously. However, the ECC will be able to initiate immediate actions to correct the problem.

A disaster involving any of BellSouth's equipment locations could impact the CLECs, some more than others. A disaster at a Central Office (CO) would only impact the delivery of traffic to and from that one location, but the incident could affect many Carriers. If the Central Office is a Serving Wire-Center (SWC), then traffic from the entire area to those Carriers served from that switch would also be impacted. If the switch functions as an Access Tandem, or there is a tandem in the building, traffic from every CO to every CLEC could be interrupted. A disaster that destroys a facility hub could disrupt various traffic flows, even though the switching equipment may be unaffected.

The NMC would be the first group to observe a problem involving BellSouth's equipment. Shortly after a disaster, the NMC will begin applying controls and finding re-routes for the

completion of as much traffic as possible. These reroutes may involve delivering traffic to alternate Carriers upon receiving approval from the CLECs involved. In some cases, changes in translations will be required. If the outage is caused by the destruction of equipment, then the ECC will assume control of the restoration.

5.2.1 Loss of a Central Office

When BellSouth loses a Central Office, the ECC will

- a) Place specialists and emergency equipment on notice;
- b) Inventory the damage to determine what equipment and/or functions are lost;
- c) Move containerized emergency equipment and facility equipment to the stricken area, if necessary;
- d) Begin reconnecting service for Hospitals, Police and other emergency agencies; and
- e) Begin restoring service to CLECs and other customers.

5.2.2 Loss of a Central Office with Serving Wire Center Functions

The loss of a Central Office that also serves as a Serving Wire Center (SWC) will be restored as described in Section 5.2.1.

5.2.3 Loss of a Central Office with Tandem Functions

When BellSouth loses a Central Office building that serves as an Access Tandem and as a SWC, the ECC will

- a) Place specialists and emergency equipment on notice;
- b) Inventory the damage to determine what equipment and/or functions are lost;
- c) Move containerized emergency equipment and facility equipment to the stricken area, if necessary;
- d) Begin reconnecting service for Hospitals, Police and other emergency agencies;
- e) Re-direct as much traffic as possible to the alternate access tandem (if available) for delivery to those CLECs utilizing a different location as a SWC;
- f) Begin aggregating traffic to a location near the damaged building. From this location, begin re-establishing trunk groups to the CLECs for the delivery of traffic normally found on the direct trunk groups. (This aggregation point may be the alternate access tandem location or another CO on a primary facility route.)
- g) Begin restoring service to CLECs and other customers.

5.2.4 Loss of a Facility Hub

In the event that BellSouth loses a facility hub, the recovery process is much the same as above. Once the NMC has observed the problem and administered the appropriate controls, the ECC will assume authority for the repairs. The recovery effort will include

- a) Placing specialists and emergency equipment on notice;
- b) Inventorying the damage to determine what equipment and/or functions are lost;
- c) Moving containerized emergency equipment to the stricken area, if necessary;
- d) Reconnecting service for Hospitals, Police and other emergency agencies; and
- e) Restoring service to CLECs and other customers. If necessary, BellSouth will aggregate the traffic at another location and build temporary facilities. This alternative would be viable for a location that is destroyed and building repairs are required.

5.3 COMBINED OUTAGE (CLEC AND BELLSOUTH EQUIPMENT)

In some instances, a disaster may impact BellSouth's equipment as well as the CLECs'. This situation will be handled in much the same way as described in Section 5.2.3. Since BellSouth and the CLECs will be utilizing temporary equipment, close coordination will be required.

6.0 T1 IDENTIFICATION PROCEDURES

During the restoration of service after a disaster, BellSouth may be forced to aggregate traffic for delivery to a CLEC. During this process, T1 traffic may be consolidated onto DS3s and may become unidentifiable to the Carrier. Because resources will be limited, BellSouth may be forced to "package" this traffic entirely differently than normally received by the CLECs. Therefore, a method for identifying the T1 traffic on the DS3s and providing the information to the Carriers is required.

7.0 ACRONYMS

- CO - Central Office (BellSouth)
- DS3 - Facility that carries 28 T1s (672 circuits)
- ECC - Emergency Control Center (BellSouth)
- CLEC - Competitive Local Exchange Carrier
- NMC - Network Management Center
- SWC - Serving Wire Center (BellSouth switch)
- T1 - Facility that carries 24 circuits

Hurricane Information

During a hurricane, BellSouth will make every effort to keep CLECs updated on the status of our network. Information centers will be set up throughout BellSouth Telecommunications. These centers are not intended to be used for escalations, but rather to keep the CLEC informed of network related issues, area damages and dispatch conditions, etc.

Hurricane-related information can also be found on line at http://www.interconnection.bellsouth.com/network/disaster/dis_resp.htm. Information concerning Mechanized Disaster Reports can also be found at this website by clicking on CURRENT MDR REPORTS or by going directly to <http://www.interconnection.bellsouth.com/network/disaster/mdrs.htm>.

BST Disaster Management Plan

BellSouth maintenance centers have geographical and redundant communication capabilities. In the event of a disaster removing any maintenance center from service another geographical center would assume maintenance responsibilities. The contact numbers will not change and the transfer will be transparent to the CLEC.

Attachment 12

Bona Fide Request and New Business Requests Process

BONA FIDE REQUEST AND NEW BUSINESS REQUESTS PROCESS

- 1.0 The Parties agree that Heritage is entitled to order any Network Element, Interconnection option, service option or Resale Service required to be made available by the Communications Act of 1934, as modified by the Telecommunications Act of 1996 (the "Act"), FCC requirements or State Commission requirements. Heritage also shall be permitted to request the development of new or revised facilities or service options which are not required by the Act. Procedures applicable to requesting the addition of such facilities or service options are specified in this Attachment 12.
- 2.0 Bona Fide Requests ("BFR") are to be used when Heritage makes a request of BellSouth to provide a new or modified network element, interconnection option, or other service option pursuant to the Act that was not previously included in the Agreement. New Business Requests ("NBRs") are to be used when Heritage makes a request of BellSouth to provide a new or custom capability or function to meet Heritage's business needs that was not previously included in the Agreement. The BFR/NBR process is intended to facilitate the two-way exchange of information between Heritage and BellSouth, necessary for accurate processing of requests in a consistent and timely fashion.
- 3.0 A BFR shall be submitted in writing by Heritage and shall specifically identify the required service date, technical requirements, space requirements and/or such specifications that clearly define the request such that BellSouth has sufficient information to analyze and prepare a response. Such a request also shall include a Heritage's designation of the request as being (i) pursuant to the Telecommunications Act of 1996 (i.e. a "BFR") or (ii) pursuant to the needs of the business (i.e. a "NBR"). The request shall be sent to Heritage's Account Executive.
- 4.0 Heritage may cancel a BFR or NBR at any time. If Heritage cancels the request more than three (3) business days after submitting it, Heritage shall pay BellSouth's reasonable and demonstrable costs of processing and/or implementing the BFR or NBR up to the date of cancellation. If Heritage does not cancel a BFR or NBR, Heritage shall pay BellSouth's reasonable and demonstrable costs of processing and implementing the request.
- 5.0 Within twenty-five (25) business days of its receipt of a BFR or NBR from Heritage, BellSouth shall respond to Heritage by providing a preliminary analysis of such Interconnection, Network Element, or other facility or service option that is the subject of the BFR or NBR. The preliminary analysis shall confirm that BellSouth will either offer access to the Interconnection, Network Element, or other facility or service

option, or provide an explanation of why it is not technically feasible and/or why the request does not qualify as an Interconnection, Network Element, or is not otherwise required to be provided under the Act.

- 6.0 If BellSouth determines that the Interconnection, Network Element, or other facility or service option that is the subject of the BFR is technically feasible, BellSouth shall propose a firm price and a detailed implementation plan within fifty (50) business days after receipt of the BFR. BellSouth may, but shall not be required to, provide a firm time and cost proposal for a NBR.
- 7.0 Within thirty (30) business days after its receipt of (i) a refusal of BellSouth to provide a BFR or NBR price quote, or (ii) the BFR or NBR price quote and implementation plan from BellSouth, Heritage must either confirm or cancel its order for such facility or service option. If it believes such quote is not consistent with the requirements of the Act, Heritage may at that time seek FCC or state Commission arbitration of its request, as appropriate. Any such arbitration applicable to Network Elements and/or Interconnection shall be conducted in accordance with standards prescribed in Section 252 of the Act.
- 8.0 Unless Heritage agrees otherwise, all prices shall be consistent with the pricing principles of the Act, FCC and/or the State Commission.
- 9.0 If either Party to a BFR or NBR believes that the other Party is not requesting, negotiating, or processing the Bona Fide Request in good faith, or disputes a determination, or price or cost quote, such Party may seek FCC or state Commission resolution of the dispute, as appropriate.
- 10.0 Upon agreement to the terms of a BFR or NBR, an amendment to the Agreement may be required.

STATE OF FLORIDA

COMMISSIONERS:
E. LEON JACOBS, JR., CHAIRMAN
J. TERRY DEASON
LILA A. JABER
BRAULIO L. BAEZ
MICHAEL A. PALECKI



DIVISION OF THE COMMISSION CLERK &
ADMINISTRATIVE SERVICES
BLANCA S. BAYÓ
DIRECTOR
(850) 413-6770 (CLERK)
(850) 413-6330 (ADMIN)

Public Service Commission

December 21, 2001

Marshall M. Criser III, Vice President Regulatory & External Affairs
BellSouth Telecommunications, Inc.
150 South Monroe Street, Suite 400
Tallahassee, Florida 32301-1556

Docket No. 011667-TP

Dear Mr. Criser:

This will acknowledge receipt of a request by BellSouth Telecommunications, Inc. for approval of interconnection, unbundling, resale, and collocation agreement with Heritage Technologies, Ltd., which was filed in this office on December 20, 2001, and assigned the above-referenced docket number. Appropriate staff members will be advised.

Mediation may be available to resolve any dispute in this docket. If mediation is conducted, it does not affect a substantially interested person's right to an administrative hearing. For more information, contact the Office of General Counsel at (850) 413-6248 or FAX (850) 413-7180.

Division of the Commission Clerk and Administrative Services
Florida Public Service Commission