



September 9, 2005

Ms. Blanca S. Bayo
Florida Public Service Commission
Director, Division of the Commission Clerk
& Administrative Services
2540 Shumard Oak Blvd
Tallahassee, Florida, 32399-0850

050601-EU

Dear Ms. Bayo:

Enclosed for filing with the Commission please find 1 original and seven copies of the following documents:

- 1) Fontainebleau Florida Tower 3, LLC d/b/a Fontainebleau III Ocean Club, Petition for Variance or Waiver From the Individual Metering Requirement of Rule 25-6.049(a) of the Florida Administrative Code with Exhibits 1-14.
- 2) Turnberry Associates letter on behalf of Fontainebleau Florida Tower 3, LLC, requesting representation by Marc Mazo.
- 3) Affidavit of Marc Mazo pursuant to Rule 28-106.107 F.A.C..

Please acknowledge your receipt and the date of filing, as well as the docket number assigned to the petition, on the duplicate copy of this letter provided for your convenience.

Thank you for your help in this matter.

Yours very truly,

Marc D. Mazo
Authorized Representative
Fontainebleau Florida Tower 3, LLC

Cc: Lori Hartglass, Esquire
Enclosures

DOCUMENT NUMBER-DATE

08637 SEP 12 05

Turnberry Associates

September 2, 2005

Ms. Blanca S. Bayo
Florida Public Service Commission
Director, Division of the Commission
Clerk and Administrative Services
2540 Shumard Oak Blvd
Tallahassee, Florida, 32399-0850

Dear Ms. Bayo:

Fontainebleau Florida Tower 3, LLC, a Florida limited liability corporation, d/b/a Fontainebleau III Ocean Club, pursuant to Rule 28-106.106, Florida Administrative Code, hereby requests representation in all proceedings before the Public Service Commission relating to its petition for master metering by:

MARC MAZO
14252 Puffin Court
Clearwater, FL 33762
Telephone (727)573-5787
Facsimile (727)573-5675

Fontainebleau Tower Florida 3, LLC, is aware of the services that Mr. Mazo can provide, and is aware that it can be represented by an attorney at its own expense and has chosen otherwise.

Thank you very much for your consideration and attention to this matter.

Yours very truly,

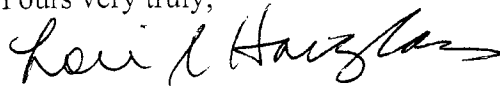

Lori R. Hartglass
Associate General Counsel
Turnberry Associates

cc: Marc Mazo

STATE OF FLORIDA
BEFORE THE PUBLIC SERVICE COMMISSION

IN RE:

Fontainebleau Florida Tower 3,
LLC, d/b/a Fontainebleau III

Docket # 050601-EU

Petitioner
_____ /

AFFIDAVIT OF MARC MAZO

STATE OF FLORIDA }
 }
PINELLAS COUNTY }

BEFORE ME, the undersigned, a notary public in and for the State of Florida at large, personally appeared MARC MAZO, who first being duly sworn upon oath, states as follows:

1. I believe I have the requisite qualifications to responsibly represent Fontainebleau Florida Tower 3, LLC., d/b/a Fontainebleau III Ocean Club, in light of the nature of the proceedings and the applicable law.

2. I have knowledge of Chapter 366, Florida Statutes, and the Rules of the Florida Administrative Code applicable to Fontainebleau III's particular situation.

3. I have knowledge of the jurisdiction of the Florida Public Service Commission and the Florida Statutes granting the PSC its powers.

4. I have knowledge of the Florida Rules of Civil Procedure relating to discovery in an administrative proceeding.

5. I have knowledge of the rules of evidence, and the

concept of hearsay used in an administrative proceeding, whereby hearsay evidence may be used to supplement or explain other evidence.

6. I have knowledge of both the legal and factual issues involved in this case.

7. I have read and have knowledge of Rule 28-106.107 Florida Administrative Code, and to the best of my ability will comply with the Standards of Conduct for Qualified Representatives.

8. I have been accepted on five previous occasions by the FPSC as a Qualified Representative. In each case the issue involved master metering and Rule 25-6.049 F.A.C.

FURTHER AFFIANT SAYETH NOT

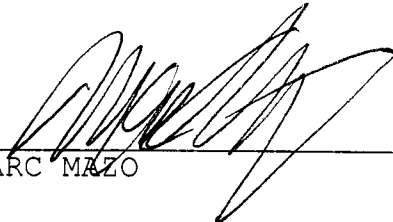

MARC MAZO

The foregoing instrument was acknowledged before me this ____ day of september, 2005, by MARC MAZO, who has produced his drivers license for identification, and DID take an oath.

My Commission Expires: 8/27/07 

Notary Public-State of Florida

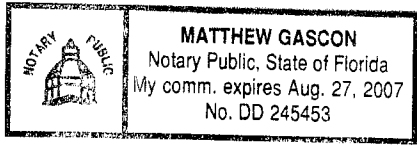

STATE OF FLORIDA
BEFORE THE PUBLIC SERVICE COMMISSION

IN RE:

Docket Number 050601-EU

Fontainebleau Florida Tower 3,
LLC, A Florida Limited Liability
Corporation, d/b/a Fontainebleau III
Ocean Club

Petitioner
_____ /

**PETITION FOR VARIANCE OR WAIVER
FROM RULE 25-6.049(5)(a)
OF THE FLORIDA ADMINISTRATIVE CODE**

Respectfully Submitted by:



MARC MAZO
Authorized Representative
FFT3 d/b/a Fontainebleau III Ocean Club
14252 Puffin Court
Clearwater, Florida 33762
Voice: 727-573-5787
Fax: 727-573-5675
Email: powck@aol.com

STATE OF FLORIDA
BEFORE THE PUBLIC SERVICE COMMISSION

IN RE:

Fontainebleau Florida Tower 3,
LLC, d/b/a Fontainebleau III

Docket # _____

Petitioner
_____ /

**PETITION FOR A VARIANCE OR WAIVER
FROM RULE 25-6.049(5) (a)
OF THE FLORIDA ADMINISTRATIVE CODE**

COMES NOW the Petitioner, Fontainebleau Florida Tower 3, LLC., a Florida Limited Liability Corporation (FFT3), d/b/a Fontainebleau III Ocean Club, and hereby petitions the Florida Public Service Commission for a variance or waiver pursuant to Section #120.542 of the Florida Statute, and Section #28-104.002 F.A.C.

I. Applicable Rule : The applicable rule from which petitioner seeks a waiver is Rule 25-6.049(5) (a) of the Florida Administrative Code, which states in pertinent part that;

(5)(a) "Individual electric metering by the utility company shall be required for each separate occupancy unit of new commercial establishments, residential buildings, condominiums, cooperatives, marinas, and trailer, mobile home and recreational vehicle parks for which construction is commenced after January 1, 1981.

The literal requirements of Rule 25-6.049(5) (a) provide that the Petitioner should maintain individual electric metering for each unit of a condominium. However, a conflict between Section 25-6.049(5) (a) and Section 25-6.049(5) (a) (3) arises when the facts of this particular case are taken into consideration.

FFT3 is the developer of a beach front Condominium Hotel called Fontainebleau III Ocean Club (FB III). The project will

contain 286 Condominium Units and 1 Hotel Unit. Ownership structure of FB III will be pursuant to Chapter 718, Florida Statutes. A copy of the pertinent documents are attached as follows: Exhibit "1" - Prospectus, Exhibit "2" - Declaration of Condominium, Exhibit "3" - By Laws, - Exhibit "4" - Articles of Incorporation, Exhibit "5" - Purchase Agreement, Exhibit "6" - Declaration of Restrictions and Reciprocal Easement Agreement, Exhibit "7" - Sample Unit Management Agreement.

FB III intends to operate as a transient rental facility in accordance with Chapter 509.242 of the Florida Statutes, or more appropriately as a Public Lodging Establishment. It will be a "Hotel" as defined by Section 509.242(1) (a), F.S., and a "Resort Condominium" as defined by Section 509.242(1) (c), F.S..

Pursuant to 509.242(1) (c), a "Resort Condominium" is any unit or group of units in a condominium, cooperative, or timeshare plan which is rented more than three times in a calendar year for periods of less than 30 days or 1 calendar month, whichever is less, or which advertises and holds out to the public as a place regularly rented for periods of less than 30 days or 1 calendar month, whichever is less.

Section 509.242(1)(a) defines a hotel as any public lodging establishment containing sleeping room accommodations for 25 or more guests and providing services generally provided by a hotel and recognized as a hotel in the community in which it is located or by the industry. Based on this definition, FB III will also be a hotel.

Rule 25-6.049(5)(a)(3), F.A.C., provides an exception to the individual metering requirement for motels, hotels, and similar

facilities. FB III believes the facts of this particular situation dictate that FB III falls within the definition of a similar facility included under the exemption covered by the rule. In pertinent part the exemption to the rule indicates that when electricity is used by the following types of entities there is no requirement to maintain individual meters for each unit:

See part (5)(a)(3), "For electric used in specialized-use housing accommodations such as hospitals, nursing homes, living facilities located on the same premises as, and occupied operated in conjunction with, a nursing home or other health care facility providing at least the same level and types of services as a nursing home, convalescent home, facilities certificated under Chapter 651, Florida Statutes, college dormitories, convents, sorority houses, fraternity houses, **motels, hotels, and similar facilities.**" (Emphasis Supplied)

II. Underlying Statute F.S. 366.05(1): The applicable portion of the underlying statute indicates that the commission shall have the power to prescribe fair and reasonable rates and charges, classifications, standards of quality measurements, and service rules and regulations to be observed by each public utility. Rule 25-6.049(5)(a) and 25-6.049(5)(a)(3) have been adopted to accomplish this principle. The implementation of fair and reasonable rates and charges by the public utility companies in Florida is a goal of the Public Service Commission established by the legislature. See F.S. 366.03.

In addition, the intent of Rule 25-6.049(5)(a) and Rule 25-6.049(5)(a)(3) is to serve the public interest regarding energy conservation. FB III believes both the underlying statute requiring fair and reasonable rates and the purpose of energy conservation are both better served, if in fact, the facility is master metered.

III. Type of Action Requested: As stated above, FB III believes it is a similar facility as described in Rule 25-6.049(5)(a)(3), F.A.C., and therefore exempt from the individual metering requirement for all intent and purpose. However, to avoid unnecessary delays and any possible confusion, FFT3 requests the Commission grant a variance or waiver from the literal requirement of Rule 25-6.049(5)(a) wherein condominiums must be individually metered, and allow FFT3 to construct FB III utilizing master metering.

IV. Facts Which Demonstrate Substantial Hardship and/or Violation of Principles of Fairness: FFT3 is the developer of Fontainebleau III Ocean Club (FB III), located or to be located at approximately the 45th block of Collins Avenue, Miami Beach, Florida. (See Exhibit "1" - Prospectus). FB III is to be constructed on the Fontainebleau Property which now contains The Fontainebleau Hotel and Fontainebleau II Condo/Hotel (which is currently under construction and was previously granted a waiver by the FPSC to allow master metering).

FFT3 intends to operate FB III as a 1st Class Beachfront Resort in a similar manner as FB II and the original Fontainebleau Hotel. FB III will share many facilities with the Fontainebleau and FB II including check-in and guest registration and PBX services, (all telephone calls to guests for the Fontainebleau, FB II, and FB III, will be routed through the main PBX located in the Fontainebleau Hotel. Calls will be made and received by guests in the same manner as in any 1st class resort hotel in Florida). In addition, advertising, marketing,

convention booking, event planning, and sales of room nights will be an integrated operation for Fontainebleau, FB II, and FB III. Current management which now has the responsibility for both the Fontainebleau and FB II, will also have the same responsibilities for FB III.

Features at the Fontainebleau available for use by guests and occupants of FB III are comparable to other world renown resorts and include: 1) 1st Class concierge service, 2) 24 hour doorman and valet, 3) ocean view poolside cafe and bar, 4) indoor/outdoor gourmet dining, 5) 24 hour room service, 6) boardroom and conference facilities, 7) housekeeping services, 8) health club and spa.

The owner of FB III, at all times intends for FB III to operate in a manner similar to a hotel as defined in Rule 25-6.049(5)(a)(3), F.A.C. Through the prospectus and sale of the condominium units, FFT3 has made it abundantly clear to all prospective purchasers that FB III is not intended to be used by anyone as a permanent residence, and is in fact intended to be used for transient rentals.

See Exhibit "1" - Prospectus - Section 10(a) Occupancy. "Each Residential Unit shall be used only in accordance with all applicable City, County and State codes, ordinances and regulations and the approvals and permits issued for the improvements, and for no other purpose. In that regard, each purchaser, is hereby advised that the City of Miami Beach's zoning designation for the Condominium Property is 'RM-3'. Pursuant to that zoning designation, the Residential Units are intended for rental to transients on a day-to-day, week-to-week, or month-to-month basis, and are not intended for use or to be used as a permanent dwelling. As a result of such zoning designation, no Unit Owner or any member of the Unit Owner's family, nor any person legally dependent upon the Unit Owner may establish a permanent residence at the Unit or any real property contiguous thereto. As such, under no circumstances shall (nor may) the Unit constitute his or her homestead, and accordingly no Unit Owner shall be entitled to file a claim for homestead

exemption from ad valorem taxes with respect to such Unit. Each purchaser shall be deemed to understand and agree that, pursuant to applicable zoning regulations, certain restrictions have been imposed on continuous occupancy of the Units to assure the transient nature of the use of the Units."

This language is repeated in Exhibit "2" - The Declaration of Condominium, Page 29, Section 16.1 Occupancy. Also, unit owners are clearly advised of the nature of the use of the condominium property in Exhibit "1" - Prospectus, Page 6, Section(e) Nuisances, 2d Paragraph; "[E]ach purchaser is hereby advised that inasmuch as hotel operations are intended to be conducted from the Condominium Property, noise and/or other disruptions may occur."

Further evidence of the intention to operate FB III as a hotel can be found in Exhibit "1" Page 12, Section 20, Disclosures. The pertinent part of the Prospectus reads, "[U]nder the laws of the State of Florida, each prospective purchaser is hereby advised as follows: (See paragraph #4), [T]he Condominium is structured to operate as a hotel. Residential Units Owners through the Association, do not exercise the control over the operation of the Condominium normally found in residential condominiums." Exhibit "5" - The Purchase Agreement - also advises the purchasers of the intent to operate as a hotel. Page 13, Section 40 - Disclosures - repeats the same language as found in the "Disclosure Section of the Prospectus".

FB III intends to use a unit management agreement for each condominium owner for the purpose of defining the parameters of the use of the units in the operation of the hotel. A sample of a prototype management agreement is attached as Exhibit "7". It is anticipated that over 90% of the unit owners will enter into a

unit management agreement with the hotel owner. The expectation is that the other 10% will either seek to rent their units through outside real estate entities, or through use of individual web sites.

Guests and occupants at FB III have been granted the right pursuant to the Declaration of Restrictions and Reciprocal Easement Agreement, attached as Exhibit "6", between the Hotel Owner and FFT3, which allows occupants and guests access to the amenities of the Hotel Space, including, the exterior grounds, pools, health clubs and spa, and services such as housekeeping, food and beverage, dry cleaning, and in room massage, to the extent the services are available.

All units will be designer furnished down to the smallest detail. See marketing and sales brochure for Fontainebleau III Ocean Club attached as Exhibit "9". Purchasers will not be given any option for individualized furnishing of their prospective unit as each unit is intended to be used in the operation of the hotel. All furnishings will be designed similarly for each unit depending on size and location within the tower, and installed to conform to the standards applied to the entire facility.

FFT3 has obtained a building permit from the City of Miami Beach to construct FB III based on the land use regulations for a hotel/condo. A copy of the permit is attached as Exhibit "8". The description on the permit in pertinent part reads, "[N]ew Construction, Fontainebleau III (New Tower)-286 HotelCondo 11003 SF Spa & Shell for Restaurant and Room Service (Mixed Use)."

As a result of its intent to operate a hotel as shown by its permit received from the City of Miami Beach for a

hotel/condo, FB III has been designed to incorporate the American Disabilities Act Guidelines (ADA), required for all hotels. Compliance with these rules is more stringent than the Florida Fair Housing Act, and requires substantially more time, effort, and money than it would for a strictly residential condominium project. A copy of the architectural drawings A-501 through A - 516 reflecting plans for ADA compliance are attached as Composite Exhibit "13".

Specifically, there are 22 units designed for compliance with ADA rules and regulations. ADA units are to be located throughout FB III. Furniture in the ADA units must be compliant for the handicapped; grab bars must be installed for toilet areas and showers, sight impaired rooms must meet sound requirements for fire safety, telephones must be installed to meet hearing impaired criteria, and FB III must have an ADA compliant elevator.

Not only is the cost to furnish ADA units higher than non-ADA units; since the ADA units are less desirable than non-ADA units, the return on investment for ADA units is lower. The 22 ADA units represent 10,107 square feet that is selling for pre-construction prices at an average of \$971.90 per square foot. The non-ADA units are selling at pre-construction prices that average \$1025 per square foot. AS a result, FFT3 will receive approximately \$546,788.87 less for the sale of ADA units compared to the sale of non-ADA units. This simply would not be the case if the project was strictly residential as the ADA requirement would not exist.

FB III will be registered with the Florida Department of Business and Professional Regulation to engage in the business of providing transient lodging accommodations. It will also be registered with the Florida Department of Revenue for collecting and remitting sales tax on revenue realized from providing such transient accommodations. Fontainebleau III will operate as a business providing short term lodging to vacationers as do hotels and motels in the adjacent and surrounding areas. It will compete directly for room night business with nearby hotels and motels from Miami Beach to Boca Raton. To maintain its market share the Fontainebleau will regularly advertise and promote Fontainebleau, FB II, and FB III for convention business and resort vacations with travel agents and in trade shows in this country and abroad.

As mentioned earlier, FB III will share the check-in facilities for guest registration with the original Fontainebleau Hotel located in the main lobby. In addition, FB III will have its own registration and check-in desk located in the new lobby of FB III. All FB III guests may check-in and check-out at either the front desk located in the lobby area of the Fontainebleau Hotel or at the front desk located in the lobby of FB III.

As stated above, the Management of the Fontainebleau Hotel will also be the same management team for FB III. The General Manager will continue to serve in the same capacity for Fontainebleau, FB II, and now FB III. His job duties for FB III will be the same as the duties he now carries out for the Fontainebleau Hotel and FB II, including oversight and supervision of housekeeping, maintenance, security, guest services, marketing and advertising.

Because FB III will be competing with other hotels and resorts in the area for guest-room nights and convention business, rates for room nights must be kept in line with the competition. Advertising dollars must also be expended to fill the needed amount of room nights. These principles exist for hotels and motels and also exist for the FB III based on its manner of operation.

FB III will have a positive financial impact on the State of Florida and the local area economy due to additional revenue generated by state sales tax and local occupancy or bed tax charged on all room rentals. This economic impact is significantly different than that of a residential condominium that generates no additional tax revenue for the state or local government. Additional hotel room availability for the Fontainebleau Resort as a whole (Fontainebleau, FB II, and FB III), has the potential of driving significant new and larger convention business for the City of Miami Beach. This translates into substantial additional revenue for other hotels and businesses in the Miami Beach area, and additional tax revenue for the City and State.

Savings analysis based on the estimated annual KWH usage for FB III shows the difference of what the resort would pay for electric if all units were individually metered and served by FP&L on its residential rate, as opposed to being master metered and served on FP&L's general service large demand rate. The savings analysis is attached as Exhibit "10".

If FB III is not master metered it will pay approximately 25% to 30% more for the same electric to operate as nearby hotels

and motels that are master metered and receive service from FP&L on the lower commercial rates. This creates a substantial hardship for FB III to compete in the room rental business and pay all the associated costs (including taxes) of operating a public lodging establishment. It also violates principles of fairness in that other hotels and motels in the surrounding area will spend less money on electricity and be able to spend more on advertising or employee salaries, or for other expenses of improving their competitive position over FB III.

According to Order # PSC-01-0626-PAA-EU, issued March 14, 2001, re: the petition of Sundestin Homeowners Association for master metering, the FPSC stated in pertinent part that, "[T]he types of facilities that are exempted from the individual metering requirement are those in which, due to their nature or mode of operation, it is not practical to attribute usage to individual occupants. For example, hotels and motels are commercial enterprises in which the occupants of the units are not billed for their use of electricity, but rather pay a bundled rate for the use of a room for a limited time."

FB III clearly falls in this category. It will be impractical, if nearly impossible, to attribute and bill electric usage to the daily and weekly guests of the resort. They will be billed a bundled rate for the limited use of the rooms rented while vacationing at FB III.

V. Conservation Issue: The development of Rule 25-6.049 was to encourage conservation of electricity. The PSC, it's Staff, and IOU's in Florida have adhered to the philosophy that

the end user will be more inclined to be conscious of conservation if such user is made aware of his or her electric use and associated costs. Section (5) (a) of the rule follows this theory by requiring individual metering. However, the implication which can be derived from this section is that condominiums are residential in nature, therefore, by requiring individual metering the owner occupant will be made aware of monthly electric usage and associated costs and will be more inclined to conserve electricity.

This theory is not applicable to FB III since it will operate as a transient rental facility catering to the traveling public. The owner/investors of units at FB III will not be responsible for energy conservation at the resort. The General Manager and/or Chief Engineer will have full responsibility for energy management and conservation at FB III, as they do for the original Fontainebleau, and Fontainebleau II, both full service resorts catering to the transient public.

To better conserve and control the use of electricity by guests at FB III, the design for the HVAC system is centralized. The condominium units contain individual air handlers only, while the cooling and heating system of chillers, condensers, and compressors that work in conjunction with the individual unit air handlers, are large centrally located units. These units are controlled by an automated energy management system. See Composite Exhibit "14" Drawings M6.01 through M7.00.

This newer technology is specifically designed for energy conservation in a hotel or resort environment. It could not be used in residential condominiums that were not intended for use

as a Hotel like FB III. Energy conservation is accomplished via a remote computer that senses the load needed for heating or cooling and sequentially brings on line the appropriate chillers to handle the required load. As the energy management system detects an increase in load it will bring on line an additional chiller as necessary. The system will also detect a drop in load, and reduce the use of chillers when appropriate. This is a highly efficient system that restricts use of the compressors and condensers to only the necessary load. This type of energy efficiency could not be accomplished if individual compressors and condensers were used in each condominium unit as is typical in residential condominiums.

In addition, Florida Power & Light has numerous energy conservation and incentive programs that will be available to FB III as a hotel that would not otherwise be available to FB III if it were strictly residential facility. FP&L offers business evaluations, help in payment for high efficiency cooling and/or energy recovery ventilation, business lighting programs, building envelope improvements, and business custom incentives. These on-going programs will be available to FB III as a hotel to help with energy conservation.

Finally, if the units at FB III are individually metered the monthly electric bills will be forwarded by the power company to owners of over two hundred eighty-six units. These owners will be located in all parts of the country and abroad with no ability to implement energy conservation except through the General Manager or Chief Engineer. Based on the FPSC interpretation of the metering rule, in this particular instance, conservation

efforts will be better served if management receives one master electricity bill and continually monitors usage and seeks improvement relating to energy efficiency.

Recognizing that FB II was intended to be operated as a transient resort, the FPSC granted a variance for FB II to allow master metering. It is clear that its sister property, FB III, is also designed for operation as a transient resort facility in the same manner as FB II.

In addition, based on their operation as transient rental facilities that are similar in nature to hotels and motels, the Commission granted a variance to the individual metering requirement for Holiday Villas II in 1998, and Sundestin Resort in 2001. The idea being that the public interest in the area of energy conservation would be better served when a resort condominium operating transient rentals receives one master bill for electric instead of many individual bills. In this manner the resort manager would have more awareness of total electric usage and hopefully as a result, pay closer attention to energy conservation and make additional efforts to conserve.

Attached is a copy of a letter from the manager of Holiday Villas II Marcus Paula, (Exhibit "11"), and the manager of Sundestin Resort Lino Maldonado, (Exhibit "12"), which shows that the FPSC position allowing those facilities that operate similar to hotels and motels to master meter, has in fact been successful by serving the goal of energy conservation. The letters show that as a result of receiving one master electric bill the electricity used in the units became an item included in the annual budget of the association and a responsibility of the resort managers. In

both cases the managers, who previously did not see the individual owners electric bills, experienced heightened awareness of energy costs for all the unit owners, an increased ability to track energy costs, and more productive effort in energy conservation and control of electricity expenses.

VI. Conclusion By granting Petitioner a waiver or variance from the individual metering requirements of Rule 25.6-049 F.A.C., the interests of the public relating to energy conservation would be better served. By receiving one bill each month at the facility the General Manager and/or Chief Engineer will be more aware of energy costs and more productive with efforts to control and conserve electricity. In addition, the principles of fairness would be met in that the FB III will be better able to compete with hotels and motels in the area as a result of not paying higher costs for electric than its hotel/motel competitors.

VII. Duration of Variance or Waiver - Petitioner requests the waiver be permanent with the condition that the FB III continues to operate a transient rental facility and maintain registration with the DBPR as a public lodging establishment in accordance with Chapter 509.242, Florida Statutes.

WHEREFORE, Petitioner respectfully requests the Public Service Commission grant its request for a variance or waiver.



MARC D. MAZO
14252 Puffin Court
Clearwater, Florida 33762
Telephone (727)573-5787
Facsimile (727)573-5675
Authorized Representative
FFT3, d/b/a Fontainebleau III Ocean Club

I HEREBY CERTIFY that an original and seven (7) copies of the foregoing Petition for Variance or Waiver have been furnished by U.S. Mail this ____ day of August, 2005, to the Public Service Commission, Attn: Ms Blanca S. Bayo, Director, Division of the Commission Clerk and Administrative Services

A handwritten signature in black ink, appearing to read 'M. Mazo', is written over a horizontal line.

MARC D. MAZO

PROSPECTUS
FOR
FONTAINEBLEAU III OCEAN CLUB CONDOMINIUM

THIS PROSPECTUS CONTAINS IMPORTANT MATTERS TO BE CONSIDERED IN ACQUIRING A CONDOMINIUM UNIT.

THE STATEMENTS CONTAINED HEREIN ARE ONLY SUMMARY IN NATURE. A PROSPECTIVE PURCHASER SHOULD REFER TO ALL REFERENCES, ALL EXHIBITS HERETO, THE CONTRACT DOCUMENTS, AND SALES MATERIALS.

ORAL REPRESENTATIONS CANNOT BE RELIED UPON AS CORRECTLY STATING THE REPRESENTATIONS OF THE DEVELOPER. REFER TO THIS PROSPECTUS AND ITS EXHIBITS FOR CORRECT REPRESENTATIONS.

INDEX

SUMMARY OF CERTAIN ASPECTS OF THE OFFERING

	<u>Page</u>
1. Description of Condominium	1
2. Condominium Structure	1
3. Recreational and Certain other Commonly Used Facilities Intended to be Constructed Within the Common Elements	2
4. Recreational and Certain other Commonly Used Facilities Intended to be Constructed Within The Hotel Unit to be Deemed Shared Components	2
5. Recreational and Certain other Facilities of the Adjoining Fontainebleau Hotel in Which Unit Owners Shall Have Limited Use Rights	3
6. Expansion of Recreational Facilities	3
7. Leasing of Developer-Owned Units	4
8. Management of the Condominium	4
9. Transfer of Control of the Association	4
10. Restrictions on Use of Units and Common Elements and Alienability	4
11. Utilities and Certain Services	8
12. Apportionment of Common Expenses and Ownership of the Common Elements	8
13. Closing Expenses; The Agreement for Sale; Escrow Deposits	9
14. Sales Commissions	10
15. Identity of Developer	10
16. Contracts to be Assigned by Developer	10
17. Nearby Construction/Natural Disturbances	10
18. Estimated Operating Budgets	11
19. Easements Located or to be Located on the Condominium Property	11
20. Disclosures	12
21. Evidence of Ownership	13
22. General	13
23. Definitions	13
24. Effective Date	14
Schedule A (Number of Bathrooms and Bedrooms in each Residential Unit)	-

EXHIBITS TO THE PROSPECTUS

		<u>Page of Exhibit</u>
A.	<u>Declaration of Condominium</u>	
1.	Introduction and Submission	1
2.	Definitions	1
3.	Description of Condominium	6
4.	Restraint Upon Separation and Partition of Common Elements	11
5.	Ownership of Common Elements and Common Surplus and Share of Common Expenses; Voting Rights	11
6.	Amendments	11
7.	Maintenance and Repairs	13
8.	Additions, Alterations or Improvements by Unit Owners	14
9.	Operation of the Condominium by the Association; Powers and Duties	16
10.	Determination of Common Expenses and Fixing of Assessments Therefor	18
11.	Collection of Assessments	18
12.	Obligation for Expenses Relating to the Hotel Unit	21
13.	Insurance	25
14.	Reconstruction or Repair After Fire or Other Casualty	27
15.	Condemnation	28
16.	Occupancy and Use Restrictions	29
17.	Selling, Leasing and Mortgaging of Units	34
18.	Compliance and Default	34
19.	Termination of Condominium	35
20.	Additional Rights of Mortgagees and Others	35
21.	Nature of Improvements	36
22.	Covenant Running With the Realty	37
23.	Disclaimer of Warranties	37
24.	Coastal Construction Control Line	38
25.	Additional Provisions	38
	<u>Exhibit 1 - Legal Description</u>	-
	<u>Exhibit 2 - Survey-Plot Plan</u>	-
	<u>Exhibit 3 - Allocation of Common Expenses</u>	-
	<u>Exhibit 4 - By-Laws of Condominium Association</u>	
	1. Identity	1
	2. Definitions	1
	3. Members	1
	4. Directors	4
	5. Authority of the Board	9
	6. Officers	11
	7. Fiduciary Duty	11
	8. Compensation	11
	9. Resignations	11
	10. Fiscal Management	12
	11. Roster of Unit Owners	15
	12. Parliamentary Rules	15
	13. Amendments	15
	14. Rules and Regulations	16
	15. Official Records	16
	16. Certificate of Compliance	16
	17. Construction	17
	18. Captions	17
	19. Electronic	18
	20. Construction	18
	21. Captions	18

Exhibit 5 - Articles of Incorporation
of Condominium Association

1.	Name	1
2.	Office	1
3.	Purpose	1
4.	Definitions	1
5.	Powers	1
6.	Members	3
7.	Term of Existence	3
8.	Incorporator	3
9.	Officers	3
10.	Directors	4
11.	Indemnification	5
12.	By-Laws	8
13.	Amendments	8
14.	Initial Registered Office; Address and Name of Registered Agent	9

Exhibit 6 - Guaranteed Assessment Schedule -

Exhibit 7 - Allocation of Hotel Shared Costs

B.	<u>Estimated Operating Budget - Condominium</u>	--
	<u>Estimated Operating Budget - Shared Components</u>	--
C.	<u>Form of Purchase Agreement</u>	--
D.	<u>Escrow Agreement</u>	--
E.	<u>Evidence of Ownership</u>	--
F.	<u>Reciprocal Easement Agreement</u>	--

PART 1

SUMMARY OF CERTAIN ASPECTS OF THE OFFERING

1. Description of Condominium

The name of the condominium is FONTAINEBLEAU III OCEAN CLUB CONDOMINIUM (the "Condominium"). The Condominium is located or to be located at approximately the 45th block of Collins Avenue, Miami Beach, Florida. FONTAINEBLEAU FLORIDA TOWER 3, LLC, a Florida limited liability company (the "Developer"), is the owner of the unsold Units in the Condominium which are being offered for sale pursuant to this Prospectus. The Condominium will contain one (1) Building having a total of two hundred eighty seven (287) Units, consisting of two hundred eighty six (286) Residential Units and one (1) Hotel Unit. Each Residential Unit shall contain the number of bedrooms and bathrooms identified on Schedule "A" attached hereto. Exhibit "2" to the Declaration of Condominium (attached hereto as Exhibit "A") consists of a survey of the Realty, a graphic description of the Improvements located thereon, including, but not limited to, the Building in which the Units are located, and a plot plan thereof. Said Exhibit "2", together with the Declaration, is sufficient in detail to identify the Common Elements and each Unit and their relative locations and dimensions.

The Condominium will consist only of the Units described herein and the Common Elements described in the Declaration of Condominium attached hereto as Exhibit "A". As described in greater detail, many of the recreational and other commonly used facilities are not part of the Common Elements, but rather are part of the Shared Components (which are part of the Hotel Unit). Accordingly, control of those facilities is vested in the Hotel Unit Owner, rather than the Association.

The estimated latest date of completion of the construction, finishing and equipping of the Condominium (but not necessarily any of the improvements included in the Shared Components) is July 31, 2007, except as provided in the Purchase Agreement set forth as Exhibit "C" hereto to the contrary. The foregoing date is given as an estimate only, and, except only as may be provided in the Purchase Agreement to the contrary, Developer shall not be liable for any damages resulting from its substantial completion of the Condominium either before or after that date. Developer shall only be bound by any completion obligations set forth in the applicable Purchase Agreements signed by the Developer.

THE CONDOMINIUM WILL BE CREATED AND UNITS WILL BE SOLD IN FEE SIMPLE INTERESTS.

2. Condominium Structure

Together, the improvements constituting the Common Elements, Residential Units and Hotel Unit have been, or shall be, constructed so as to contain, among other things, a single unified structure, existing, generally upon a parking structure. The parking structure is not included in the Condominium Property, but rather, residents of the Condominium are granted certain rights therein as, and only to the extent, more particularly described in that certain Declaration of Restrictions and Reciprocal Easement Agreement (the "Reciprocal Easement Agreement"), a copy of which is included in this Prospectus as Exhibit "F" attached hereto. Accordingly, the Condominium Property shall be governed and burdened by, and subject to, and each Unit Owner shall be governed and burdened by, and subject to, all of the terms and conditions of the Reciprocal Easement Agreement. Each purchaser agrees that the rights in and to the Condominium Property are junior and subordinate to the rights granted under the Reciprocal Easement Agreement, and agrees to be bound by the terms thereof.

Given the integration of the improvements to be constructed within the Condominium Property, and notwithstanding anything to the contrary depicted on the survey/plot plan attached to the Declaration, the following components of the improvements (the "Shared Components") shall be deemed part of the Hotel Unit, whether or not graphically depicted as such on said survey/plot plan: any and all structural components of the Improvements, including, without limitation, all exterior block walls and all finishes (glass, paint, stucco etc) and balconies, terraces and/or facades attached or affixed thereto; the roof; all roof trusses, roof support elements and roofing insulation; all utility, mechanical, electrical, telephonic, telephone switchboard, Life Safety Systems, telecommunications, plumbing and other systems, including, without limitation, all wires, conduits, pipes, ducts, transformers, cables and other apparatus used in the delivery of the utility, mechanical, telephonic, telecommunications, electrical, plumbing, Life Safety Systems and/or other services or systems; all heating, ventilating and air conditioning systems, including, without limitation, compressors, air handlers, ducts, chillers, water towers and other apparatus used in the delivery of HVAC services (except only for the portions of any of same serving only one Unit other than the Hotel Unit); all elevator shafts, elevator cabs, elevator cables and/or systems and/or equipment used in the operation of the elevators transversing the Condominium Property; all trash rooms and any and all trash collection and/or disposal systems. In addition, the Shared Components include the following areas and/or facilities contained within the Condominium Property (together with a license for reasonable pedestrian access thereto, as determined by the Owner of the Hotel Unit): the main hotel lobby, the pool(s) and the pool deck(s), if any, which may be located from time to time within the improvements constructed upon the Hotel Unit. Notwithstanding the designation of the main hotel lobby and the pool(s) and pool deck(s); as part of the Shared Components, the Hotel Unit Owner shall have the

right to regulate the use thereof, including, without limitation, establishing hours of operation, and designating certain services offered from those facilities as a la carte. Notwithstanding anything contained to the contrary, the Shared Components shall be deemed part of the Hotel Unit. The Hotel Unit Owner shall have the right (but not the obligation), by Supplemental Declaration executed by the Hotel Unit Owner alone, to designate additional portions of the Hotel Unit as Shared Components. Notwithstanding the designation of the Shared Components, the Hotel Unit Owner shall have the right, from time to time, to expand, alter, relocate and/or eliminate the portions of the Hotel Unit deemed Shared Components (provided that expansion shall not be beyond the Hotel Unit), without requiring the consent or approval of the Association or any Owner, provided that any portions withdrawn are not, in the reasonable opinion of the Hotel Unit Owner essential to the structural integrity of the Residential Units, the provision of utilities and utility services to the Residential Units and/or the provision of legal access. In furtherance of the foregoing, the Hotel Unit Owner also reserves the absolute right at any time, and from time to time, to construct additional facilities within the Hotel Unit and to determine whether same shall be deemed Shared Components. Further, notwithstanding their designation as Shared Components, subject to the right of the Hotel Unit Owner to regulate their uses, the balconies, lanais and/or rooftop terraces directly serving a Unit shall be reserved for the exclusive use of the Unit afforded direct access thereto and that exclusive use right shall be an appurtenance which passes with title to the Unit. Without limiting the generality of the foregoing, any and all food and beverage operations and/or business center(s), whether now or hereafter located upon the Hotel Unit, shall expressly be excluded from the Shared Components and shall be deemed the exclusive property, and for the exclusive use, of the owner from time to time of the Hotel Unit and such persons or entities designated by the Hotel Unit Owner. It is expressly contemplated that persons other than Unit Owners shall be granted use rights in and to certain of the facilities of the Hotel Unit (such determination to be made in the sole and absolute discretion of the Hotel Unit Owner).

3. Recreational and Certain Other Commonly Used Facilities Intended to be Constructed Within the Common Elements

There are not intended to be any recreational or other commonly used facilities constructed upon the Common Elements.

4. Recreational and Certain Other Commonly Used Facilities Intended to be Constructed Within The Hotel Unit to be Deemed Shared Components

The following facilities are intended to be constructed within the Hotel Unit and are to be included within the Shared Components. Except as provided in the Declaration to the contrary, these facilities may be used by Owners of Units in the Condominium, their guests, tenants and invitees, by the Owner of the Hotel Unit, its guests, tenants and invitees and by any other persons permitted by the Hotel Unit Owner, including, without limitation, all guests of the hotel intended to be operated upon the Hotel Unit. Notwithstanding the foregoing, the Hotel Unit Owner shall have the right to establish rules and regulations regarding the use of these facilities, including, without limitation, rules to temporarily close off the facilities for private functions and parties, and rules to prohibit dual usage of facilities by a Unit Owner and a tenant of the Unit during periods when a Unit is being rented or is available for rental. The facilities are currently intended to include the following (all to be located on designated portions of the Hotel Unit):

<u>FACILITY AND ITS LOCATION</u>	<u>APPROXIMATE SIZE</u>	<u>APPROXIMATE CAPACITY</u>
Pool Deck (5 th level)	6,065 sq. ft.	203 persons
Heated Pool (5 th level)	834 sq. ft. with a depth from 3 feet to 5 feet	17 persons
Board Room (Lower Lobby)	410 sq. ft.	28 persons
Social Room (with Bar) (1 st Level)	2,542 sq. ft.	128 persons
Mail Room (1 st Level)	435 sq. ft.	5 persons

The facilities described above are intended to be constructed. The design, commencement and progress of any such construction, however, will be in the sole discretion of the Hotel Unit Owner, with use restricted, if at all, in the manner determined by the Hotel Unit Owner. The maximum number of Residential Units which may be located within the Condominium at the time any of the above-described facilities may be constructed will not exceed two hundred eighty six (286) Units, subject to increase or decrease at any time and from time to time, depending on a

variety of factors including, but not limited to, revised development plans, market conditions and governmental controls. Developer intends to expend approximately \$100,000.00 to provide certain personal property in and around these facilities (to be selected in the sole discretion of Developer).

5. Recreational and Certain Other Facilities of the adjoining Fontainebleau Hotel in which Unit Owners Shall Have Limited Use Rights

The following facilities are part of the Fontainebleau Hotel, which is adjacent to the Condominium. Pursuant to (and limited by the terms of) the Reciprocal Easement Agreement, Unit Owners and their guests, tenants and invitees will have the right to use these facilities in common with the guests of the Fontainebleau Hotel.

<u>FACILITY AND ITS LOCATION</u>	<u>APPROXIMATE SIZE</u>	<u>APPROXIMATE CAPACITY</u>
Hotel Lagoon Pool (Heated)	11,000 sq. ft. with depth from 3' to 6'	206 persons
Children's Entertainment Zone	10,000 sq. ft.	220 persons
Spas (2)	165 sq. ft. ea.	16 persons ea.
Pool Deck	18,000 sq. ft.	320 persons
Fitness Center	5,000 sq. ft.	450 persons

The foregoing facilities are not part of the Condominium Property, and accordingly, shall not be governed, operated or regulated by the Association or any of the Unit Owners. Governance of these facilities, including, without limitation, any and all decisions regarding hours of operation, alterations to facilities, removal of facilities and others, shall be made in the sole discretion of the owner from time to time of the Fontainebleau Hotel. Unit Owners shall only have such rights to use the facilities to the extent provided by the Reciprocal Easement Agreement. Each purchaser is hereby advised that the Fontainebleau Hotel is intended (without creating any obligation) to be substantially renovated. In the event that such renovations are undertaken: (i) there may be changes, modifications and/or elimination of any of the existing recreational facilities of the Fontainebleau Hotel, (ii) operation of the Fontainebleau Hotel may be closed for up to one (1) year to accommodate the renovations, and (iii) noise, construction debris, excessive traffic and other inconveniences may result therefrom. The nature of any changes and/or elimination of facilities can not presently be determined nor can the length of time, if any, that operations from the Fontainebleau Hotel may be terminated. Each purchaser understands and agrees to the potential for renovations, assumes all risks associated with same, and hereby releases the Developer from any and all damages, liabilities and/or inconveniences which may result therefrom.

6. Expansion of Recreational Facilities

RECREATIONAL FACILITIES MAY BE EXPANDED OR ADDED WITHOUT CONSENT OF UNIT OWNERS OR THE CONDOMINIUM ASSOCIATION.

See Section 6.4 and Section 8.3 of the Declaration.

As to the facilities contained within the Shared Components, the Hotel Unit Owner reserves the right at any time to eliminate, provide, alter or expand any of the above-described recreational facilities of the Hotel Unit as the Hotel Unit Owner deems appropriate. The consent of the Unit Owners or the Condominium Association shall not be required for any such construction, expansion or other determination. The cost of any such construction or expansion shall be borne exclusively by the Hotel Unit Owner. The Hotel Unit Owner is not obligated, however, to so expand any facilities or provide additional facilities.

As to the facilities contained within the Fontainebleau Hotel, in addition to effecting the renovations described above, the owner from time to time of the Fontainebleau Hotel (the "Fontainebleau Hotel Owner") reserves the right at any time to eliminate, provide, alter or expand any of such recreational facilities as Fontainebleau Hotel Owner deems appropriate. The consent of the Unit Owners or the Condominium Association shall not be required for any such construction, expansion or other determination. The cost of any such construction or expansion shall be borne exclusively by the Fontainebleau Hotel Owner. The Fontainebleau Hotel Owner is not obligated, however, to so expand any facilities or provide additional facilities.

7. Leasing of Developer-Owned Units

THE UNITS MAY BE TRANSFERRED SUBJECT TO A LEASE.

See Sections 16.7 and 17 of the Declaration of Condominium for further details. As it is intended that the Units may be used for transient and/or hotel rentals, the Developer intends to engage in a program of renting or leasing unsold Units upon such terms as Developer shall approve and as permitted by the Act and the rules promulgated thereunder. In the event any Unit is sold prior to the expiration of the term of a lease (which may occur during an indefinite period), title to such Unit (or Units) will be conveyed subject to the lease (or leases) and purchasers will succeed to the interests of the applicable lessor. If any Unit is sold subject to a lease, a copy of the executed lease will be attached to the Agreement for Sale in accordance with the terms of Florida Statutes, Section 718.503(1)(a)(4). If a Unit has been previously occupied, the Developer will so advise a prospective purchaser, in writing, prior to the time that the purchaser is requested to execute a Purchase Agreement, if required by law.

8. Management of the Condominium

There is not presently a contract for the management of the Common Elements. The Association may, however, enter into an agreement with a manager to serve the Common Elements. Any such management agreement, in addition to the means of termination which may be provided in the agreement, may be cancelled by unit owners pursuant to the Condominium Act, Florida Statutes, Section 718.302. Section 718.302(1)(a), Florida Statutes, provides in relevant part that:

If . . . unit owners other than the developer have assumed control of the association, or if unit owners other than the developer own not less than 75 percent of the units in the condominium, the cancellation shall be by concurrence of the owners of not less than 75 percent of the units other than the units owned by the developer. If a grant, reservation or contract is so cancelled and the unit owners other than the developer have not assumed control of the association, the association shall make a new contract or otherwise provide for maintenance, management or operation in lieu of the cancelled obligation, at the direction of the owners of not less than a majority of the units in the condominium other than the units owned by the developer.

Any fees which may be payable by the Association to a Manager shall be part of the Common Expenses of the Condominium that are included in the Assessments payable by Unit Owners.

Currently, there are no maintenance or service contracts affecting the Common Elements having a non-cancellable term in excess of one (1) year. The Association is empowered at any time and from time to time, to enter into such maintenance and/or service contracts affecting the Common Elements for valuable consideration and upon such terms and conditions as the Board of Directors shall approve without the consent of Unit Owners. Any maintenance and/or service contracts may be subject to cancellation by the Association and by Unit Owners directly in accordance with the aforesaid Section 718.302, Florida Statutes. Similarly, the Hotel Unit Owner is empowered at any time and from time to time, to enter into maintenance and/or service contracts affecting the Shared Components for valuable consideration and upon such terms and conditions as the Hotel Unit Owner shall approve without the consent of the Condominium Association or the Unit Owners.

9. Transfer of Control of the Association

The initial officers and directors of the Condominium Association are or will all be designees of the Developer.

THE DEVELOPER HAS THE RIGHT TO RETAIN CONTROL OF THE CONDOMINIUM ASSOCIATION AFTER A MAJORITY OF THE UNITS HAVE BEEN SOLD.

With respect to the control of the Association, see Section 718.301, Florida Statutes, and Section 4.15 of the By-Laws of the Association, a copy of which By-Laws is set forth as Exhibit "4" to the Declaration of Condominium. The Directors of the Condominium Association designated by the Developer will be replaced by Directors elected by Unit Owners other than the Developer no later than is required by the applicable provisions of the Florida Condominium Act, Section 718.301, Florida Statutes.

10. Restrictions on Use of Units and Common Elements and Alienability.

The following is a summary of certain of the restrictions which affect the Units. To the extent permitted by the Act, the Developer and certain related parties are exempt from these restrictions.

(a) Occupancy. Each Residential Unit shall be used only in accordance with all applicable City, County and State codes, ordinances and regulations and the approvals and permits issued for the Improvements,

and for no other purpose. In that regard, each purchaser, is hereby advised that the City of Miami Beach's zoning designation for the Condominium Property is "RM-3". Pursuant to that zoning designation, the Residential Units are intended for rental to transients on a day-to-day, week-to-week, or month-to-month basis, and are not intended for use or to be used as a permanent dwelling. As a result of such zoning designation, no Unit Owner nor any member of the Unit Owner's family, nor any person legally dependent upon the Unit Owner may establish a permanent residence at the Unit or any real property contiguous thereto. As such, under no circumstances shall (nor may) the Unit constitute his or her homestead, and accordingly, no Unit Owner shall be entitled to file a claim for homestead exemption from ad valorem taxes with respect to such Unit. Each purchaser shall be deemed to understand and agree that, pursuant to applicable zoning regulations, certain restrictions have been imposed on continuous occupancy of the Units and to assure the transient nature of the use of the Units. Accordingly, each Unit shall be bound by all such restrictions. Each purchaser understands that it shall be bound by the limitations of the zoning designation and expressly releases the Developer, and Hotel Unit Owner (and its and their members, and its and their partners, shareholders and employees) from any and all liabilities and/or damages resulting from same. The Hotel Unit may be used for any lawful purpose, and may be used by the Owner(s) thereof and its/their guests, tenants and invitees. The provisions of this subsection shall not be applicable to Units used by the Developer for model apartments, sales or resales offices or management or administrative services.

The rights of Residential Unit Owners to use the Shared Components shall be limited to the extent granted in, and subject to the restrictions of, Section 3.4(d) of the Declaration and the obligation for payment of the assessments and charges as set forth in Section 12 of the Declaration (provided, however, that in no event shall an Owner be denied access to and from the Owner's Unit). It is contemplated (but without creating an obligation whatsoever) that in addition to use as a typical hallway for pedestrian passage, the Hotel Unit may be utilized by the Hotel Unit Owner in such a manner as to provide, or cause to be provided, certain hotel-related services to Residential Unit Owners, all of which shall be subject to rules, regulations and/or conditions as may be established by the Hotel Unit Owner from time to time in its sole and absolute discretion, including, without limitation, the right to require any person requesting such services to sign such agreements and pay such fees as may be required from time to time by the Hotel Unit Owner. The Hotel Unit Owner is not required to provide any hotel related services, but if it determines to do so, in its sole discretion, it may condition the provisions of such services in any manner it so desires.

(b) Pet Restrictions. Not more than two (2) domesticated pets (either dogs, cats, or a dog and cat, provided that there are not more than two (2) such pets in total) may be maintained in a Residential Unit provided such pets: (a) do not, at maturity, weigh in excess of eighty (80) pounds each, (b) are permitted to be so kept by applicable laws and regulations, (c) are not kept, bred or maintained for any commercial purpose, (d) do not become a nuisance or annoyance to neighbors, and (e) are not a breed considered to be dangerous or a nuisance by the Hotel Unit Owner (in its sole and absolute discretion); provided that neither the Hotel Unit Owner, the Board, the Developer nor the Association shall be liable for any personal injury, death or property damage resulting from a violation of the foregoing and any occupant of a Unit committing such a violation shall fully indemnify and hold harmless the Hotel Unit Owner, the Board, the Developer, each Unit Owner and the Association in such regard. No reptiles or wildlife shall be kept in or on the Condominium Property (including Units). Unit Owners must pick up all solid wastes of their pets and dispose of such wastes appropriately. All pets (including cats) must be kept on a leash of a length that affords reasonable control over the pet at all times when outside the Unit. No pets may be kept on patio areas or on balconies of any Units when the Owner is not in the Unit. Pets may not be taken in any elevators in the Condominium other than in the service elevator(s). Violation of the provisions of this Section shall entitle the Hotel Unit Owner to all of its rights and remedies, including, but not limited to, the right to fine Unit Owners (as provided in any applicable rules and regulations) and/or to require any pet to be permanently removed from the Condominium Property. This Section shall not prohibit the keeping of fish or a caged household-type bird(s) in a Residential Unit, provided that a bird(s) is not kept on Limited Common Elements or becomes a nuisance or annoyance to neighbors.

(c) Third Party Service Providers. The Hotel Unit Owner shall have the right, in its sole and absolute discretion, to establish reasonable regulations from time to time with respect to the provision of hotel services by third party providers, including, but not limited to, solicitation and/or provision of housekeeping services, pool services, valet services, engineering services, personal services (i.e., massage, personal training, dry cleaning, etc.) and/or food and beverage service, to the Condominium, the Unit Owners and their guests, tenants and invitees.

(d) Alterations. No Residential Unit Owner shall cause or allow improvements or changes to any Residential Unit, Shared Components, Common Elements or Association Property, including, but not limited to, painting or other decorating of any nature, installing any electrical wiring, television antenna, machinery, or air-conditioning units, which in any manner change the appearance of any portion of the Building or the exterior of said Unit, without obtaining the prior written consent of the Association (as to the Common Elements only) or the Hotel Unit Owner (as to all other portions of the Condominium Property, in the manner specified in the Declaration. Further, any Unit which is built out for handicap accessibility and/or compliance with applicable disability requirement of City, State or Federal law, must be maintained in that condition and can not be altered. Additionally, curtains or drapes (or linings thereof) which face the exterior windows or glass doors of Units shall be consistent with the standard adopted from time to time by the Hotel Unit Owner. Notwithstanding the provisions set forth above, any

Unit Owner may display one portable, removable United States flag in a respectful way, and, on Armed Forces Day, Memorial Day, Flag Day, Independence Day and Veterans Day, may display in a respectful way portable, removable official flags, not larger than 4 1/2 feet by 6 feet, that represent the United States Army, Navy, Air Force, Marine Corps or Coast Guard.

The Hotel Unit Owner shall have the right to establish non-discriminatory restrictions on any and all persons performing work within the Condominium Property, including, without limitation, by (a) restricting the hours during which work may be performed and restricting access of contractors to certain areas, (b) requiring that all persons performing any work have all necessary licenses and permits to perform the work, (c) requiring that all persons performing any work have adequate insurance coverage and that the Association be a named additional insured on such policy(ies), and (d) requiring a security deposit or other collateral to protect against damage that may be caused during such work.

(e) Nuisances. No nuisances (as defined by the Hotel Unit Owner) shall be allowed on the Condominium or Association Property, nor shall any use or practice be allowed which is a source of annoyance to occupants of Units or which interferes with the peaceful possession or proper use of the Condominium and/or Association Property by its residents, occupants or members. No activity specifically permitted by the Declaration, including, without limitation, activities or businesses conducted from the Hotel Unit, shall be deemed a nuisance.

Each purchaser is hereby advised that inasmuch as hotel operations are intended to be conducted from the Condominium Property, noise and/or other disruptions may occur. By acquiring a Unit, each Unit Owner, for such Unit Owner and its guests, tenants and invitees, and its and their successors and/or assigns, agrees not to object to the operations of the hotel, which may include, noise, disruption and the playing of music outdoors, and hereby agrees to release Developer and the Hotel Unit Owner from any and all claims for damages, liabilities and/or losses suffered as a result of the existence of the hotel and the operations from same, and the noises and disruptions resulting therefrom.

(f) No Improper Uses. No improper, offensive, hazardous or unlawful use shall be made of the Condominium or Association Property or any part thereof, and all valid laws, zoning ordinances and regulations of all governmental bodies having jurisdiction thereover shall be observed. Violations of laws, orders, rules, regulations or requirements of any governmental agency having jurisdiction thereover, relating to any portion of the Condominium and/or Association Property, shall be corrected by, and at the sole expense of, the party obligated to maintain or repair such portion of the Condominium Property, as elsewhere herein set forth. No activity specifically permitted by the Declaration shall be deemed to be a violation of this paragraph.

(g) Leases. It is intended that the Residential Units may be used for transient and/or hotel rentals. As such, leasing of Units or portions thereof shall not be subject to the approval of the Association and/or any other limitations, other than as expressly provided herein. However, all leasing of Units or portions thereof shall be made in accordance with all applicable zoning ordinances and other limitations imposed by the City of Miami Beach.

The lease of a Residential Unit for a term of six (6) months or less is subject to a tourist development tax assessed pursuant to Section 125.0104, Florida Statutes. A Residential Unit Owner leasing his or her Unit for a term of six (6) months or less agrees, and shall be deemed to have agreed, for such Owner, and his or her heirs, personal representatives, successors and assigns, as appropriate, to hold the Association, the Developer and all other Unit Owners harmless from and to indemnify them for any and all costs, claims, damages, expenses or liabilities whatsoever, arising out of the failure of such Unit Owner to pay the tourist development tax and/or any other tax or surcharge imposed by the State of Florida, the County or the City with respect to rental payments or other charges under the lease, and such Unit Owner shall be solely responsible for and shall pay to the applicable taxing authority, prior to delinquency, the tourist development tax and/or any other tax or surcharge due with respect to rental payments or other charges under the lease.

Every lease of a Unit shall specifically provide (or, if it does not, shall be automatically deemed to provide) that a material condition of the lease shall be the tenant's full compliance with the covenants, terms, conditions and restrictions of the Declaration (and all Exhibits thereto) and with any and all rules and regulations adopted by the Hotel Unit Owner from time to time, including, without limitation, any and all regulations and/or procedures established by applicable law and/or adopted by the Hotel Unit Owner regarding mandatory check-in for Owners and residents, coordination of charging privileges and other matters reasonably necessary to allow Owners and hotel guests to be well integrated into a unified structure and operation. The Unit Owner will be jointly and severally liable with the tenant to the Association and/or Hotel Unit Owner, as applicable, for any amount which is required by the Association and/or the Hotel Unit Owner to repair any damage to the Common Elements, the Hotel Unit and/or the Shared Components resulting from acts or omissions of tenants (as determined in the sole discretion of the Association as to Common Elements or the Hotel Unit Owner as to the Hotel Unit or Shared Components) and to pay any claim for injury or damage to property caused by the negligence of the tenant and special charges may be levied against the Unit therefor. All tenancies are hereby made subordinate to any lien filed by the Condominium Association or the Hotel Unit Owner, whether prior or subsequent to such lease. Notwithstanding the foregoing,

there shall be no minimum lease term for the rental of Residential Units, nor shall there be a maximum number of times that a Residential Unit may be leased.

(h) Weight and Sound Restrictions. Hard and/or heavy surface floor coverings, including, without limitation, tile or wood, may not be installed in any part of a Unit other than the kitchen and bathroom(s), without the consent of the Hotel Unit Owner. The Hotel Unit Owner shall not approve the installation of any hard and/or heavy surface floor coverings (for which approval is required) unless the aggregate sound isolation and acoustical treatment carries a minimum Sound Transmission Classification (STC) of 48 and a minimum Impact Isolation Classification (IIC) of 46. The installation of the foregoing insulation materials shall be performed in a manner that provides proper mechanical isolation of the flooring materials from any rigid part of the building structure, whether of the concrete subfloor (vertical transmission) or adjacent walls and fittings (horizontal transmission) and must be installed prior to the Unit being occupied. Notwithstanding the foregoing and the provisions of Section 8.1 of the Declaration, the floor coverings (and insulation and adhesive material therefor) installed on any balcony or patio shall not exceed a thickness of seven eighths of one inch (7/8"). Also, the installation of any improvement or heavy object must be submitted to and approved by the Hotel Unit Owner, and be compatible with the overall structural design of the building. The Hotel Unit Owner may require a structural engineer to review certain of the proposed improvements, with such review to be at the Owner's sole expense. Owners will be held strictly liable for violations of these restrictions and for all damages resulting therefrom and the Hotel Unit Owner has the right to require immediate removal of violations. Each purchaser is hereby advised that sound transmission in a high-rise building such as the Condominium is very difficult to control, and that noises from adjoining or nearby Units and or mechanical equipment can often be heard in another Unit. The Developer does not make any representation or warranty as to the level of sound transmission between and among Units and the other portions of the Condominium Property, and/or from elevators or mechanical equipment, and each purchaser hereby waives and expressly releases any such warranty and claim for loss or damages resulting from sound transmission.

(i) Exterior Improvements. Without limiting the generality of Sections 8.1 or 16.4 of the Declaration, but subject to any provision of the Declaration specifically permitting same, no Unit Owner shall cause anything to be affixed or attached to, hung, displayed or placed on the exterior walls, doors, balconies or windows of the Building (including, but not limited to, awnings, signs, storm shutters, screens, window tinting, furniture, fixtures and equipment), without the prior written consent of the Hotel Unit Owner.

(j) Access to Units. In order to facilitate access to Units by the Association for the purposes enumerated in Section 9.1 of the Declaration, it shall be the responsibility of all Unit Owners to deliver a set of keys (or access card or code, as may be applicable) to their respective Units to the Association and the Hotel Unit Owner to use in the performance of its functions. No Owner shall change the locks to his or her Unit. The Hotel Unit Owner shall have the right to adopt reasonable regulations from time to time regarding access control and check-in, check-out procedures which shall be applicable to both hotel guests and Unit Owners.

(k) Mitigation of Dampness and Humidity. No Unit Owner shall install, within his or her Unit, or upon the Common Elements or Association Property, non-breathable wall-coverings, low-permeance paints or mirrored wall coverings. Additionally, any and all built-in casework, furniture, and or shelving in a Unit must be installed over floor coverings to allow air space and air movement and shall not be installed with backboards flush against any gypsum board wall. Additionally, all Unit Owners, whether or not occupying the Unit, shall periodically run the air conditioning system to maintain the Unit temperature, whether or not occupied, no higher than 78°F, to minimize humidity in the Unit. Leaks, leaving exterior doors or windows open, wet flooring and moisture will contribute to the growth of mold, mildew, fungus or spores. Each Unit Owner, by acceptance of a deed, or otherwise acquiring title to a Unit, shall be deemed to have agreed that neither Developer, nor the Hotel Unit Owner is responsible, and each hereby disclaims any responsibility for any illness, personal injury, death or allergic reactions which may be experienced by the Unit Owner, its family members and/or its or their guests, tenants and invitees and/or the pets of all of the aforementioned persons, as a result of mold, mildew, fungus or spores. It is the Unit Owner's responsibility to keep the Unit clean, dry, well-ventilated and free of contamination. While the foregoing are intended to minimize the potential development of molds, fungi, mildew and other mycotoxins, each Owner understands and agrees that there is no method for completely eliminating the development of molds or mycotoxins. The Developer does not make any representations or warranties regarding the existence or development of molds or mycotoxins and each Owner shall be deemed to waive and expressly release any such warranty and claim for loss or damages resulting from the existence and/or development of same. In furtherance of the foregoing, in the event that the Association and/or the Hotel Unit Owner reasonably believes that the provisions of this Section are not being complied with, then, the Association and/or the Hotel Unit Owner shall have the right (but not the obligation) to enter the Unit (without requiring the consent of the Owner or any other party) to turn on the air conditioning in an effort to cause the temperature of the Unit to be maintained as required hereby.

(l) Antennas, Satellite Dishes. To the extent permitted by applicable law, no Owner may install any antenna, satellite dish or other transmitting or receiving apparatus in or upon his or her Unit (and/or areas appurtenant thereto), without the prior written consent of the Hotel Unit Owner.

(m) Parking. All vehicle parking shall be by valet only and subject to the procedures, rules and regulations adopted from time to time pursuant to the Reciprocal Easement Agreement.

(n) Storage on Balconies/Terraces. No equipment, materials or other items shall be kept or stored on any balcony or terrace area of the Condominium, including but not limited to towels, clothing, bicycles. The foregoing shall not prevent, however, placing and using patio-type furniture, planters and other items in such areas if same are normally and customarily used for a residential balcony or terrace area, but all such patio furniture, planters and others must be reasonably acceptable to the Hotel Unit Owner. In the event of any doubt or dispute as to whether a particular item is permitted hereunder, the decision of the Hotel Unit Owner shall be final and dispositive.

(o) Open House. No person shall be permitted to have an "open house", a "broker's open" or host any other event intended to attract multiple prospects at a single time, in connection with any attempt to sell or lease a Unit.

THE SALE, LEASE, OR TRANSFER OF UNITS IS RESTRICTED OR CONTROLLED.

For these and other restrictions upon the use of Units and Common Elements, reference should be made to all Exhibits contained in this Prospectus (particularly Sections 8, 16 and 17 of the Declaration) in addition to the specific references noted.

11. Utilities and Certain Services

Utilities and certain other services will be furnished to the Condominium as follows:

Electricity	Florida Power & Light Company
Telephone	BellSouth
Water	City of Miami Beach
Sanitary Sewage and Waste Disposal	City of Miami Beach
Solid Waste Removal	Private Contractor(s) (to be determined)
Storm Drainage	Private system of natural and artificial percolation and run-off

All telephone service within the Units is intended to operate through a central switchboard controlled by the Hotel Unit Owner (and which shall be deemed part of the Shared Components). Each Unit Owner, in addition to payment of the allocable share of the Shared Costs, shall also be obligated for payment of such usage charges as may be established from time to time by the Hotel Unit Owner in connection with usage of the switchboard, which may include, without limitation, long distance charges, long distance and local access surcharges and/or per call or per minute fees. All other utilities are anticipated to be billed to the Association (as to the Common Elements) or the Hotel Unit Owner (as to the Shared Components) and shall be paid for through Assessments or the Hotel Shared Costs.

12. Apportionment of Common Expenses and Ownership of the Common Elements

The Owner(s) of each Unit will own an undivided percentage interest in the Common Elements of the Condominium and Common Surplus of the Condominium Association and shall be obligated for a percentage share of the Common Expenses, said shares being set forth on Exhibit "3" to the Declaration of Condominium. The Common Expenses include all expenses incurred by the Association for the operation, maintenance, repair, replacement or protection of the Common Elements and Association Property, the costs of carrying out the powers and duties of the Association, and any other expense, whether or not included in the foregoing, designated as a "Common Expense" by the Act, the Declaration, the Articles or the Bylaws. Common Expenses shall also include, without limitation: (a) all reserves required by the Act or otherwise established by the Association, regardless of when reserve funds are expended; (b) if applicable, insurance for directors and officers; (c) the real property taxes, Assessments and other maintenance expenses attributable to any Units acquired by the Association or any Association Property and/or rental or other expenses owed in connection with any Units leased by the Association; (d) any obligations, financial or otherwise, of the Owners from time to time of the Condominium Property under the Reciprocal Easement Agreement, all of which are expressly assumed by the Association and (e) any unpaid share of Common Expenses or Assessments extinguished by foreclosure of a superior lien or by deed in lieu of foreclosure. Common Expenses shall not include any separate obligations of individual Unit Owners. Each Unit's percentage

interest in the Common Elements and Common Surplus and percentage share of the Common Expenses will be as set forth in the Declaration, same being calculated generally based upon the relative square footage of each Unit.

In addition to the Assessments payable to the Association, each Unit Owner shall be obligated for payment of sums to the Hotel Unit Owner for use and enjoyment of the Shared Components. See Section 12 of the Declaration.

THE HOTEL UNIT OWNER HAS A LIEN RIGHT AGAINST EACH UNIT TO SECURE THE PAYMENT OF HOTEL SHARED COSTS OR OTHER EXACTIONS COMING DUE FOR THE MAINTENANCE, OPERATION, UPKEEP AND REPAIR THE SHARED COMPONENTS, ALL AS DEFINED IN THE DECLARATION OF CONDOMINIUM. THE FAILURE TO MAKE THESE PAYMENTS, WHETHER BY THE CONDOMINIUM ASSOCIATION OR THE UNIT OWNER MAY RESULT IN FORECLOSURE OF THE LIEN ON THE INDIVIDUAL UNITS.

See Section 12 of the Declaration.

13. Closing Expenses; The Agreement for Sale; Escrow Deposits

At the time of closing of title, the purchaser will pay a "development fee" equal to one and three quarters percent (1.75%) of the Purchase Price (and of any charges for options or extras now or hereafter contracted for which are not included in the Purchase Price). This fee will be used, in part, to pay for the following closing costs: (i) the costs of officially recording the deed in the Public Records of the County (presently, recording fees are \$10.00 for the first page of an instrument and \$8.50 for each additional page), (ii) the documentary stamp taxes payable in connection with the deed conveying the Unit to Buyer (presently, documentary stamp taxes are \$.60 for each \$100.00 of consideration), and (iii) for the premium on the owner's title insurance policy, at the minimum promulgated risk rates promulgated by the Florida Insurance Commissioner (taking into account applicable reissue rates and new home credits, if any), whether obtained from Developer's closing agent or elsewhere. The balance of the "development fee" shall be retained by Developer as additional revenue and to offset certain of its conversion and development expenses, including without limitation, certain of Developer's administration expenses and Developer's attorneys' fees in connection with conversion and development of the Condominium. Accordingly, Buyer understands and agrees that the development fee is not for payment of closing costs or settlement services (other than to the extent expressly provided above), but rather represents additional funds to Developer which are principally intended to provide additional revenue and to cover various out-of-pocket and internal costs and expenses of Developer associated with development of the Condominium. In the event of increases in either the recording fees imposed by the County, the documentary stamp tax rates or the minimum risk title insurance premiums, subsequent to the date of this Agreement, or in the event of the imposition of the Miami-Dade County surtax, or any surcharge or any new governmental tax or charge on deeds or conveyances, Buyer agrees to pay all such increases, surcharges or new taxes or charges, in addition to the development fee. Purchaser will also pay any sales tax due in connection with the acquisition of any furnishings, finishes and/or equipment.

At the time of closing of title, the purchaser will also make a contribution to the funds of the Condominium Association, said contribution to be in an amount equal to the aggregate of two (2) times the regular monthly assessment for the Unit due the Condominium Association as determined at the time of closing and two (2) times the regular monthly allocated amount for the Unit due the Hotel Unit Owner with respect to the Hotel Shared Costs as determined at the time of closing. These charges will not be credited against regular assessments or charges, with respect to the contribution for the Hotel Shared Costs, shall be payable directly to the Hotel Unit Owner and may be used to pay any deficits or other sums the Hotel Unit Owner or any of its affiliates may be required to pay. Notwithstanding the foregoing intent, however, all contributions may be used by the entity for any purpose.

Purchasers shall also be required to pay, at closing: (i) the surtax, if any payable in connection with the conveyance of the Unit (presently, surtax is \$.45 for each \$100.00 of consideration); (ii) any and all sales tax due in connection with the acquisition of any furnishings, finishes and/or equipment; (iii) a reimbursement to Developer for any utility, cable or interactive communication deposits or hook-up fees which Developer may have advanced prior to closing for the Unit, (iv) the remaining balance, if any, of any charges for options or upgrading of standard items included, or to be included, in the Unit, (v) reimbursement to Developer, and/or Developer's closing agents, for charges incurred in connection with coordinating closing with a purchaser and/or the purchaser's lender, including, without limitation, charges for messenger expenses, long distance telephone calls, photocopying expenses, telecopying charges and others; (vi) a refundable damage deposit to offset any damages that may be caused during purchaser's move-in and (vii) late charges, if applicable, all as provided in the Agreement. In addition, purchasers shall be required to pay the remaining balance, if any, of any charges for options or upgrading of standard items included, or to be included, in the Unit as agreed to in writing by both purchaser and Developer.

If the Developer permits a closing to be rescheduled from the originally scheduled closing date at the request of a purchaser, such purchaser shall pay to the Developer, at the time of rescheduling, a late closing charge

determined in the manner set forth in the Purchase Agreement. In addition, all closing prorations shall be made as of the originally scheduled closing date. Developer is not obligated to consent to any such delay.

In addition, if purchaser obtains a loan for any portion of the Purchase Price, purchaser will be obligated to pay any loan fees, closing costs, escrows, appraisals, credit fees, lender's title insurance premiums, prepayments and all other expenses charged by any lender giving purchaser a mortgage, if applicable. Additionally, if purchaser obtains a loan and elects to have Developer's closing agent act as "loan" closing agent as well, purchaser agrees to pay, in addition to any other sums described in this Agreement, such closing agent an aggregate sum equal to \$795.00, for a simultaneously issued mortgagee's title insurance policy, the agent's title examination, title searching and closing services related to acting as "loan closing agent". In addition to that sum, purchaser shall be obligated to pay the premiums (at promulgated rate) for any title endorsements requested by purchaser's lender. Notwithstanding any of the references in this paragraph to coordinating closing with any lender that purchaser may elect to obtain, nothing herein shall be deemed to make the Agreement, or the purchaser's obligations under the Agreement, conditional or contingent in any manner on the purchaser obtaining a loan to finance any portion of the Purchase Price; it being the agreement of the purchaser that the purchaser shall be obligated to close "all cash".

The Developer is not obligated to provide a purchaser with a title opinion or an abstract of title. A policy of owner's title insurance, however, will be provided to a purchaser after closing.

The form of Purchase Agreement set forth as Exhibit "C" hereto may be modified in any manner in any particular case or cases without the consent of any other purchaser or Unit Owner (provided, however, that no amendment may conflict with the provisions of Chapter 718, Florida Statutes). The modification of any such Purchase Agreement or Purchase Agreements shall not vest any purchaser or Unit Owner whose Purchase Agreement was not so modified with any rights of any sort. Deposits under the Purchase Agreement will be held and disbursed in accordance with the Purchase Agreement and the terms of the Escrow Agreement attached hereto as Exhibit "D".

14. Sales Commissions

The Developer will pay the sales commissions, if any, of any exclusive broker retained by it and/or any in-house sales personnel retained by Developer in connection with the sale of the Units. The purchaser will be responsible for the commission of any other broker or salesman with whom purchaser may have dealt, unless Developer otherwise agrees in writing.

15. Identity of Developer

FONTAINEBLEAU FLORIDA TOWER 3, LLC, a Florida limited liability company, is the Developer of the Condominium. Being a relatively newly formed entity, it has no prior experience in the area of condominium or other real estate development. Mr. Jeffrey Soffer is affiliated with the Developer and has day to day responsibility for directing the creation and sale of the Condominium and he has substantial experience in condominium development, having been involved with development of Porto Vita in Aventura, Florida, Oceania V in Sunny Isles Beach, Florida, Tumberry Place and Tumberry Ocean Colony in Sunny Isles Beach, Florida and Fontainebleau II, a Condominium.

The information provided above as to Mr. Soffer is given solely for the purpose of complying with Section 718.504(22), Florida Statutes, and is not intended to create or suggest any personal liability on the part of Mr. Soffer.

16. Contracts to be Assigned by Developer

Upon or before closing of title to the first Unit, Developer shall assign to the appropriate Association all of Developer's right, title and interest in and to all contracts relating to the provision of utilities, insurance and other services to the Condominium, and from and after such date, all benefits and burdens thereunder shall accrue and apply to the applicable Association. The Developer shall be entitled to be reimbursed for all deposits, prepaid premiums, rentals and other consideration paid by the Developer to such insurers, contractors and utility companies, pro-rated as of the date of closing for each Unit, except that the deposits for utilities will be reimbursed in full without proration.

17. Nearby Construction/Natural Disturbances

The Owners of Units in the Condominium may for some time in the future be disturbed by the noise, commotion and other unpleasant effects of nearby construction and/or renovation activity and impeded in using portions of the project by that activity. As set forth above, it is contemplated that renovation of the Fontainebleau Hotel may be undertaken adjacent to the Condominium Property and, if undertaken, each purchaser

should expect to be affected by the noise and commotion resulting therefrom. Without limiting the generality of the foregoing, Purchaser understands and agrees that for some time in the future, purchaser may be disturbed by the noise, commotion and other unpleasant effects of renovations to the Fontainebleau Hotel and/or nearby construction activity and purchaser may be impeded in using portions of the Condominium Property or facilities of the Fontainebleau Hotel (to the extent permitted by the Reciprocal Easement Agreement) by that activity. Because the Condominium is located in an urban area, demolition or construction of buildings and other structures within the immediate area or within the view lines of any particular Unit or of any part of the Condominium (the "Views") may block, obstruct, shadow or otherwise affect Views, which may currently be visible from the Unit or from the Condominium. Therefore, the purchaser hereby agrees to release Developer and every affiliate and person related or affiliated in any way with the Developer ("Developer's Affiliates") from and against any and all losses, claims, demands, damages, costs and expenses of whatever nature or kind, including attorney's fees and costs, including those incurred through all arbitration and appellate proceedings, related to or arising out of any claim against the Developer or Developer's Affiliates related to Views. As a result of the foregoing, there is no guarantee of view, security, privacy, location, design, density or any other matter, except as is set forth herein or in the Prospectus. Additionally, inasmuch as the Hotel Unit may attract customers, patrons and/or guests who are not members of the Association, such additional traffic over and upon the Condominium Property shall not be deemed a nuisance hereunder.

Among other acts of God and uncontrollable events, hurricanes have occurred in South Florida and, as waterfront property, the Condominium is exposed to the potential damages of hurricanes, including, but not limited to, damages from storm surges and wind-driven rain. Water or other damages from this or other extraordinary causes shall not be the responsibility of the Developer.

Further, given the climate and humid conditions in South Florida, molds, mildew, toxins and fungi may exist and/or develop within the Unit and/or the Condominium Property. Each Owner is hereby advised that certain molds, mildew, toxins and/or fungi may be, or if allowed to remain for a sufficient period may become, toxic and potentially pose a health risk. By acquiring title to a Unit, each Owner shall be deemed to have assumed the risks associated with molds, mildew, toxins and/or fungi and to have released the Developer and Hotel Unit Owner from any and liability resulting from same, including, without limitation, any liability for incidental or consequential damages (which may result from, without limitation, the inability to possess the Unit, inconvenience, moving costs, hotel costs, storage costs, loss of time, lost wages, lost opportunities and/or personal injury and death to or suffered by any of Buyer's Guests as defined below and any other person or any pets). Without limiting the generality of the foregoing, leaks, leaving exterior doors or windows open, wet flooring and moisture will contribute to the growth of mold, mildew, fungus or spores. Buyer understands and agrees that neither Developer nor the Hotel Unit Owner is responsible for, and each hereby disclaims any responsibility for any illness or allergic reactions which may be experienced by Buyer, its pets, its family members and/or its or their guests, tenants and invitees (collectively "Buyer's Guests") as a result of mold, mildew, fungus or spores. It is solely the Buyer's responsibility to keep the Unit clean, dry, well-ventilated and free of contamination.

18. Estimated Operating Budgets

Attached hereto as Exhibit "B" is the Estimated Operating Budget for the Condominium Association. Buyer understands that the Estimated Operating Budget provides only an estimate of what it will cost to run the Association during the period of time stated in the Budget. The Budget, however, is not guaranteed to accurately predict actual expenditures. It is intended that the Developer, as the sole Unit Owner upon the formation of the Condominium, will vote not to provide any reserves for the initial year of the Association. Thereafter, on an annual basis, a majority of the Association's members may vote to continue not to provide any reserves. If such a vote is in fact made to waive reserves, the assessments per Unit will be as set forth in the Estimated Operating Budget as "Assessments per Unit - Without Reserves". If no such vote is made, the assessments per Unit will be as set forth in the Estimated Operating Budget as "Assessments per Unit - With Reserves".

A proposed Estimated Operating Budget for the Shared Components is also set forth as part of Exhibit "B". It is anticipated that this Estimated Operating Budget for the Shared Components shall provide for reserves.

19. Easements Located or to be Located on the Condominium Property

In addition to the Reciprocal Easement Agreement and the various easements provided in the Declaration of Condominium attached hereto as Exhibit "A", the Condominium Property may be made subject to easements in favor of various public or private utilities. Any easement in favor of a public or private utility or similar company or authority may be granted by the Developer or the Association on a "blanket" basis or by use of a specific legal description. See the Section hereof entitled "Utilities and Certain Services" for the names of the suppliers of certain utilities to the Condominium.

Purchaser understands and agrees that inasmuch as the Condominium Property does not contain trash chutes, each Owner shall be obligated to follow such trash removal procedures as may be established from time to time by the Hotel Unit Owner. To the extent that the Hotel Unit Owner determines (without any obligation to do so) to remove trash directly from each Unit, then: (i) an easement is reserved to allow the Hotel Unit Owner (or its employees, agents or contractors) access to each Unit for such purpose, and (ii) all costs in connection with trash removal shall be deemed part of the Shared Costs.

For more details, refer to the Declaration of Condominium. The easements provided for in the Declaration of Condominium and the Florida Condominium Act are not summarized here.

20. Disclosures

Under the laws of the State of Florida, each prospective purchaser is hereby advised as follows:

- RADON GAS: Radon is a naturally occurring radioactive gas that, when it has accumulated in a building in sufficient quantities, may present health risks to persons who are exposed to it over time. Levels of radon that exceed federal and state guidelines have been found in buildings in Florida. Additional information regarding radon and radon testing may be obtained from your county health department. The foregoing notice is provided in order to comply with state law and is for informational purposes only. Developer does not conduct radon testing with respect to the Condominium and specifically disclaims any and all representations or warranties as to the absence of radon gas or radon producing conditions in connection with the Condominium.
- CHAPTER 558, FLORIDA STATUTES CONTAINS IMPORTANT REQUIREMENTS YOU MUST FOLLOW BEFORE YOU MAY BRING ANY LEGAL ACTION FOR AN ALLEGED CONSTRUCTION DEFECT IN YOUR UNIT OR CONDOMINIUM. SIXTY DAYS BEFORE YOU BRING ANY LEGAL ACTION, YOU MUST DELIVER TO THE OTHER PARTY TO THIS AGREEMENT, A WRITTEN NOTICE REFERRING TO CHAPTER 558 OF ANY CONSTRUCTION CONDITIONS YOU ALLEGE ARE DEFECTIVE AND PROVIDE SUCH PERSON THE OPPORTUNITY TO INSPECT THE ALLEGED CONSTRUCTION DEFECTS AND TO CONSIDER MAKING AN OFFER TO REPAIR OR PAY FOR THE ALLEGED CONSTRUCTION DEFECTS. YOU ARE NOT OBLIGATED TO ACCEPT ANY OFFER WHICH MAY BE MADE. THERE ARE STRICT DEADLINES AND PROCEDURES UNDER THIS FLORIDA LAW WHICH MUST BE MET AND FOLLOWED TO PROTECT YOUR INTERESTS.
- PURCHASER SHOULD NOT RELY ON THE DEVELOPER'S CURRENT PROPERTY TAXES AS THE AMOUNT OF PROPERTY TAXES THAT THE PURCHASER MAY BE OBLIGATED TO PAY IN THE YEAR SUBSEQUENT TO PURCHASE. A CHANGE OF OWNERSHIP OR PROPERTY IMPROVEMENTS TRIGGERS REASSESSMENTS OF THE PROPERTY THAT COULD RESULT IN HIGHER PROPERTY TAXES. IF YOU HAVE ANY QUESTIONS CONCERNING VALUATION, CONTACT THE COUNTY PROPERTY APPRAISER'S OFFICE FOR INFORMATION.
- The Condominium is structured to operate as a hotel. Residential Unit Owners, through the Association, do not exercise the control over the operation of the Condominium normally found in residential condominiums.
- The zoning designation for the Condominium Property is "RM-3". Pursuant to that zoning designation, the Residential Units are intended for rental to transients on a day-to-day, week-to-week, or month-to-month basis, and are not intended for use or to be used as a permanent dwelling. As a result of such zoning designation, no Unit Owner nor any member of the Unit Owner's family, nor any person legally dependent upon the Unit Owner may establish a permanent residence at the Unit or any real property contiguous thereto. As such, under no circumstances shall (nor may) the Unit constitute his or her homestead, and accordingly, no Unit Owner shall be entitled to file a claim for homestead exemption from ad valorem taxes with respect to such Unit.
- Inasmuch as the Condominium has been constructed with post tension cables and/or rods, absolutely no penetration shall be made to any floor, roof or ceiling slabs without the prior written consent of the Board of Directors and review of the as-built plans and specifications for the Building to confirm the approximate location of the post tension cables and/or rods. The plans and specifications for the Building shall be maintained by the Association as part of its official records. Each Unit Owner, by accepting a deed or otherwise acquiring title to a Unit shall be deemed to: (i) have assumed the risks associated with post tension construction, and (ii) agree that the penetration of any post tension cables and/or rods may threaten the structural integrity of the Building and/or cause physical harm. Each Owner shall be deemed to have released Developer and Hotel Unit Owner, its and their members, contractors, architects, engineers, and its and their

officers, directors, shareholders, employees and agents from and against any and all liability that may result from penetration of any of the post tension cables and/or rods.

- Each purchaser is hereby advised that there are various methods for calculating the square footage of a Unit, and that depending on the method of calculation, the quoted square footage of a Unit may vary by more than a nominal amount. Additionally, marketing materials may calculate the square footage of Units in a manner different than that set forth in the Declaration of Condominium and the Act. Therefore, marketing materials may understate or overstate the square footage of Units as calculated pursuant to the Declaration of Condominium and the Condominium Act. Additionally, as a result of field construction, other permitted changes to the Unit, interior columns that are not a part of the Unit, actual location of drywall and settling and shifting of improvements, actual square footage of a Unit may also be affected. Accordingly, during the pre-closing inspection, each purchaser should, among other things, review the size and dimensions of the Unit. By closing, each purchaser shall be deemed to have conclusively agreed to accept the size and dimensions of the Unit, regardless of any variances in the square footage. Neither Developer nor Hotel Unit Owner makes any representation or warranty as to the actual size, dimensions (including ceiling heights) or square footage of any Unit.

21. Evidence of Ownership

Developer is under contract to obtain title to the property which is intended to be developed as the Condominium. Attached as Exhibit "E" to this Prospectus is evidence of the Developer's interest in and to the Condominium Property.

22. General

The foregoing is not intended to present a complete summary of all of the provisions of the various documents referred to herein. Statements made as to the provisions of such documents are qualified in all respects by the content of such documents.

23. Definitions

The definitions set forth in the Declaration of Condominium shall be applicable to this Prospectus, unless otherwise specifically stated or unless the context would prohibit.

24. Effective Date

This Prospectus is effective March, 2005.

Schedule A

Number of Bathrooms and Bedrooms in Each Unit

UNIT TYPE	UNIT DESIGNATION	NUMBER OF BEDROOMS	NUMBER OF BATHROOMS
A	509, 609, 709, 809, 909, 1009, 1109, 1209, 1409, 1509, 1609, 1709	1	1
A2	1809, 1909	1	1
B	514, 614, 714, 814, 914, 1014, 1114, 1214, 1414, 1514, 1614, 1714	1	1
B2	1814, 1914	1	1
C1	619, 719, 819	1	1
C2	919, 1019, 1119, 1219, 1419, 1519, 1619, 1719, 1817, 1917	1	1
D	302, 303, 304, 305, 306, 402, 403, 404, 405, 406, 502, 503, 504, 505, 506, 602, 603, 604, 605, 606, 702, 703, 704, 705, 706, 802, 803, 804, 805, 806, 901, 902, 903, 904, 905, 906, 1001,	1	1
D1	307, 407, 507, 607, 707, 807, 907, 1007, 1107, 1207, 1407, 1507, 1607, 1707, 1807, 1907	1	1
D2	301, 401, 501, 601, 701, 801	1	1
E	510, 511, 512, 513, 610, 611, 612, 613, 710, 711, 712, 713, 810, 811, 812, 813, 910, 911, 912, 913, 1010, 1011, 1012, 1013, 1110, 1111, 1112, 1113, 1210, 1211, 1212, 1213, 1410, 1411, 1412, 1413, 1510, 1511, 1512, 1513, 1610, 1611, 1612, 1613, 1710, 1711,	1	1
F	615, 616, 617, 618, 715, 716, 717, 718, 815, 816, 817, 818, 915, 916, 917, 918, 1015, 1016, 1017, 1018, 1115, 1116, 1117, 1118, 1215, 1216, 1217, 1218, 1415, 1416, 1417, 1418, 1515, 1516, 1517, 1518, 1615, 1616, 1617, 1618, 1715, 1716, 1717, 1718, 1813, 1	1	1
G	311, 312, 313, 314, 315, 317, 411, 412, 413, 414, 415, 417	1	1
G2	318, 418		
H	310, 410	1	1
I	316, 416	1	1
J	309, 409	1	1
K	521, 522, 621, 622, 721, 722	1	1

K2	520, 620, 720	1	1
L	523, 623, 723	1	1
M	320, 420	1	1
N	319, 419	1	1
TOWER SUITE	512 & 612		

This instrument prepared by, or under the supervision
of (and after recording, return to):

Gary A. Saul, Esq.
Greenberg Traurig, P.A.
1221 Brickell Avenue
Miami, FL 33131

(Reserved for Clerk of Court)

Exhibit "A"

DECLARATION
OF
FONTAINEBLEAU III OCEAN CLUB CONDOMINIUM

FONTAINEBLEAU FLORIDA TOWER 3, LLC, a Florida limited liability company, hereby declares:

1. Introduction and Submission.

- 1.1 The Realty. The Developer (as hereinafter defined) owns fee title to certain real property located in Miami-Dade County, Florida, as more particularly described in **Exhibit "1"** attached hereto (the "Realty").
- 1.2 Reciprocal Easement. The Realty is benefited and burdened by that certain Declaration of Restrictions and Reciprocal Easement Agreement dated _____ and recorded _____ in Official Records Book _____, Page _____, of the Public Records of Miami-Dade County, Florida (the "Reciprocal Easement Agreement"), which, among other things, grants certain rights to the Unit Owners over and upon the adjoining properties more particularly described as the "Hotel Space" and "Entry/Garage Space" in the Reciprocal Easement Agreement (the "Easement Parcel").
- 1.3 Submission Statement. The Developer hereby submits the Realty and all improvements erected or to be erected thereon and all other property, real, personal (excluding any furniture or furnishings within a Unit) or mixed, now or hereafter situated on or within the Realty - but excluding all public or private (e.g. cable television) utility installations, and all leased property therein or thereon - and use rights in and to the Easement Parcel (but not the title thereto) in the manner provided in the Reciprocal Easement Agreement, to the condominium form of ownership and use in the manner provided for in the Florida Condominium Act as it exists on the date hereof and as it may be hereafter renumbered. Without limiting any of the foregoing, no property, real, personal or mixed, not located within or upon the Realty, shall for any purposes be deemed part of the Condominium or be subject to the jurisdiction of the Association, the operation and effect of the Florida Condominium Act or any rules or regulations promulgated pursuant thereto, unless expressly provided. Without limiting any of the foregoing, no portion of the fee title of the Easement Parcel shall for any purposes be deemed part of the Condominium or be subject to the jurisdiction of the Association, the operation and effect of the Florida Condominium Act or any rules or regulations promulgated pursuant thereto. Only the use rights granted in the Reciprocal Easement Agreement and the obligations imposed on the grantee thereunder shall be deemed part of the Condominium and subject to the jurisdiction of the Association, the operation and effect of the Florida Condominium Act and any rules or regulations promulgated pursuant thereto.
- 1.4 Name. The name by which this condominium is to be identified is **FONTAINEBLEAU III OCEAN CLUB CONDOMINIUM** (hereinafter called the "Condominium").

2. Definitions. The following terms when used in this Declaration and in its exhibits, and as it and they may hereafter be amended, shall have the respective meanings ascribed to them in this Section, except where the context clearly indicates a different meaning:
- 2.1 "Act" means the Florida Condominium Act (Chapter 718 of the Florida Statutes) as it exists on the date hereof and as it may be hereafter renumbered.
 - 2.2 "Allocated Interests" shall have the meaning ascribed to it in Section 5.1 below.
 - 2.3 "Articles" or "Articles of Incorporation" mean the Articles of Incorporation of the Association, as amended from time to time.
 - 2.4 "Assessment" means a share of the funds required for the payment of Common Expenses which from time to time is assessed against the Unit Owner.
 - 2.5 "Association" or "Condominium Association" means FONTAINEBLEAU III OCEAN CLUB CONDOMINIUM ASSOCIATION, INC., a Florida corporation not for profit, the sole entity responsible for the operation of the Common Elements of the Condominium.
 - 2.6 "Association Property" means that property, real and personal, which is owned or leased by, or is dedicated by a recorded plat to, the Association for the use and benefit of its members.
 - 2.7 "Board" or "Board of Directors" means the board of directors, from time to time, of the Association.
 - 2.8 "Building" means the structure(s) in which the Units and the Common Elements are located, regardless of the number of such structures, which are located on the Condominium Property.
 - 2.9 "By-Laws" mean the By-Laws of the Association, as amended from time to time.
 - 2.10 "City" shall mean and refer to the City of Miami Beach, located within the County (as hereinafter defined).
 - 2.11 "Committee" means a group of Board Members, Unit Owners or Board Members and Unit Owners appointed by the Board or a member of the Board to make recommendations to the Board regarding the Association budget or to take action on behalf of the Board.
 - 2.12 "Common Elements" mean and include:
 - (a) The portions of the Condominium Property which are not included within the Units.
 - (b) An easement of support in every portion of a Unit which contributes to the support of the Building.
 - (c) Use rights in and to the Easement Parcel solely to the extent provided by, and in accordance with the terms and conditions of, the Reciprocal Easement Agreement. Nothing herein shall be deemed to submit the fee title to the Easement Parcel to the provisions of this Declaration, nor to the terms and conditions of the Act or the rules and regulations, and same is expressly excluded from the Condominium Property and the dominion of the Association.
 - (d) Any other parts of the Condominium Property designated as Common Elements in this Declaration.

The Condominium has been established in such a manner to minimize the Common Elements. Most components which are typical "common elements" of a condominium

have instead been designated herein as part of the Shared Components of the Hotel Unit, including, without limitation, all property and installations required for the furnishing of utilities and other services to more than one Unit or to the Common Elements, if any.

- 2.13 "Common Expenses" mean all expenses incurred by the Association for the operation, maintenance, repair, replacement or protection of the Common Elements and Association Property, the costs of carrying out the powers and duties of the Association, and any other expense, whether or not included in the foregoing, designated as a "Common Expense" by the Act, the Declaration, the Articles or the Bylaws. For all purposes of this Declaration, "Common Expenses" shall also include, without limitation: (a) all reserves required by the Act or otherwise established by the Association, regardless of when reserve funds are expended; (b) if applicable, insurance for directors and officers; (c) the real property taxes, Assessments and other maintenance expenses attributable to any Units acquired by the Association or any Association Property and/or rental or other expenses owed in connection with any Units leased by the Association; (d) any obligations, financial or otherwise, of the owners from time to time of the Condominium Property under the Reciprocal Easement Agreement (as hereinafter defined), all of which are expressly assumed by the Association and (e) any unpaid share of Common Expenses or Assessments extinguished by foreclosure of a superior lien or by deed in lieu of foreclosure. Common Expenses shall not include any separate obligations of individual Unit Owners, including, without limitation, any sums payable to the Hotel Unit Owner (as hereinafter defined).
- 2.14 "Common Surplus" means the amount of all receipts or revenues, including Assessments, rents or profits, collected by the Association which exceeds Common Expenses.
- 2.15 "Condominium Parcel" means a Unit together with the undivided share in the Common Elements which is appurtenant to said Unit; and when the context permits, the term includes all other appurtenances to the Unit.
- 2.16 "Condominium Property" means the Realty, Improvements and other property described in Section 1.3 hereof, subject to the limitations thereof and exclusions therefrom, including, without limitation, the easement rights in and to the Easement Parcel (but not fee title) granted under the Reciprocal Easement Agreement.
- 2.17 "County" means the County of Miami-Dade, State of Florida.
- 2.18 "Declaration" or "Declaration of Condominium" means this instrument and all exhibits attached hereto, as same may be amended from time to time.
- 2.19 "Developer" means **FONTAINEBLEAU FLORIDA TOWER 3, LLC**, a Florida limited liability company, its successors and such of its assigns as to which the rights of Developer hereunder are specifically assigned. Developer may assign all or a portion of its rights hereunder, or all or a portion of such rights in connection with specific portions of the Condominium. In the event of any partial assignment, the assignee shall not be deemed the Developer, but may exercise such rights of Developer as are specifically assigned to it. Any such assignment may be made on a nonexclusive basis. The rights of Developer under this Declaration are independent of the Developer's rights to control the Board of Directors of the Association, and, accordingly, shall not be deemed waived, transferred or assigned to the Unit Owners, the Board or the Association upon the transfer of control of the Association.
- 2.20 "Dispute", for purposes of Section 18.1, means any disagreement between two or more parties that involves: (a) the authority of the Board, under any law or under this Declaration, the Articles or By-Laws to: (i) require any Owner to take any action, or not to take any action, involving that Owner's Unit; or (ii) alter or add to a Common Element; or (b) the failure of the Association, when required by law or this Declaration, the Articles or

By-Laws to: (i) properly conduct elections; (ii) give adequate notice of meetings or other actions; (iii) properly conduct meetings; or (iv) allow inspection of books and records. "Dispute" shall not include any disagreement that primarily involves title to any Unit or Common Element; the interpretation or enforcement of any warranty; or the levy of a fee or Assessment or the collection of an Assessment levied against a party.

- 2.21 "Division" means the Division of Florida Land Sales, Condominiums and Mobile Homes of the Department of Business and Professional Regulation, State of Florida, or its successor.
- 2.22 "Easement Parcel" shall have the meaning ascribed to it in Section 1.2 above. The fee title to the Easement Parcel is NOT part of the Condominium Property, and nothing herein shall be deemed to grant to the Owners any rights in or to the Easement Parcel other than as are expressly granted in the Reciprocal Easement Agreement.
- 2.23 "Easement Parcel Owner" shall mean the fee owner(s) from time to time of the Easement Parcel. The Easement Parcel Owner is NOT an Owner (as same is defined in this Declaration) simply by virtue of owning the Easement Parcel.
- 2.24 "First Mortgagee" means any person or entity holding a first mortgage on a Unit or Units.
- 2.25 "Hotel Shared Costs" shall have the meaning given in Section 12.1 below. The Hotel Shared Costs are not Common Expenses.
- 2.26 "Hotel Unit" means and refers to the "Hotel Unit" as identified on Exhibit "2" attached hereto, which includes the Shared Components (as hereinafter defined). References herein to "Units" or "Parcels" shall include the Hotel Unit unless the context would prohibit or it is otherwise expressly provided.
- 2.27 "Hotel Unit Owner" means and refers to the owner(s) from time to time of the Hotel Unit.
- 2.28 "Improvements" mean all structures and artificial changes to the natural environment (exclusive of landscaping) located on the Condominium Property (but excluding the Easement Parcel) including, but not limited to, the Building.
- 2.29 "Institutional First Mortgagee" means a bank, savings and loan association, insurance company, mortgage company, government sponsored entity, real estate or mortgage investment trust, pension fund, an agency of the United States Government, mortgage banker, the Federal National Mortgage Association ("FNMA"), the Federal Home Loan Mortgage Corporation ("FHLMC"), any lender advancing funds to Developer secured by an interest in any portion of the Condominium Property, or any other lender generally recognized as an institutional lender, or the Developer, holding a first mortgage on a Unit or Units.
- 2.30 "Insured Property" shall have the meaning given to it in Subsection 13.2(a) below.
- 2.31 "Life Safety Systems" mean and refer to any and all emergency lighting, emergency generators, audio and visual signals, safety systems, sprinklers and smoke detection systems, which are now or hereafter installed in the Building, whether or not within the Units. All such Life Safety Systems, together with all conduits, wiring, electrical connections and systems related thereto, regardless of where located, shall be deemed part of the Shared Components hereunder. Without limiting the generality of the foregoing, when the context shall so allow, the Life Safety Systems shall also be deemed to include all means of emergency ingress and egress, which shall include all stairways and stair landings. Notwithstanding the breadth of the foregoing definition, nothing herein shall be deemed to suggest or imply that the Building or the Condominium contains all such Life Safety Systems.

- 2.32 "Material Amendment" shall have the meaning given to it in Subsection 6.2 below.
- 2.33 "Primary Institutional First Mortgagee" means the Institutional First Mortgagee which owns, at the relevant time, Unit mortgages securing a greater aggregate indebtedness than is owed to any other Institutional First Mortgagee.
- 2.34 "Realty" shall have the meaning given to it in Section 1.1 above.
- 2.35 "Reciprocal Easement Agreement" shall have the meaning ascribed to it in Section 1.2 above.
- 2.36 "Residential Unit" means and refers to each of the Units other than the Hotel Unit. References herein to "Units" or "Parcels" shall include Residential Units unless the context prohibits or it is otherwise expressly provided. The term "Residential Unit" is used for ease of reference only as is not intended to suggest or imply that the Unit may be occupied as a permanent residence. Use of Residential Units shall be restricted by the terms of the applicable zoning and other governmental restrictions imposed by the City (and/or its quasi-governmental agencies) and by the provisions of this Declaration.
- 2.37 "Residential Unit Owner" means and refers to the owner(s) from time to time of any Residential Unit.
- 2.38 "Shared Components". Together, the improvements constituting the Common Elements, Residential Units and Hotel Unit have been, or shall be, constructed so as to contain, among other things, a single unified structure. Given the integration of the structure of those improvements, and notwithstanding anything to the contrary depicted on the survey/plot plan attached hereto as Exhibit "2", the following components of the improvements (the "Shared Components") shall be deemed part of the Shared Components of the Hotel Unit, whether or not graphically depicted as such on said survey/plot plan: any and all structural components of the Improvements, including, without limitation, all exterior block walls and all finishes (glass, paint, stucco etc) and balconies, terraces and/or facades attached or affixed thereto; the roof; all roof trusses, roof support elements and roofing insulation; all utility, mechanical, electrical, telephonic, telephone switchboard, Life Safety Systems, telecommunications, plumbing and other systems, including, without limitation, all wires, conduits, pipes, ducts, transformers, cables and other apparatus used in the delivery of the utility, mechanical, telephonic, telecommunications, electrical, plumbing, Life Safety Systems and/or other services or systems; all heating, ventilating and air conditioning systems, including, without limitation, compressors, air handlers, ducts, chillers, water towers and other apparatus used in the delivery of HVAC services (except only for the portions of any of same serving only one Unit other than the Hotel Unit); all elevator shafts, elevator cabs, elevator cables and/or systems and/or equipment used in the operation of the elevators transversing the Condominium Property; all trash rooms and any and all trash collection and/or disposal systems. In addition, the Shared Components include the following areas and/or facilities contained within the Condominium Property (together with a license for reasonable pedestrian access thereto, as determined by the Owner of the Hotel Unit): the main hotel lobby, the pool(s) and pool deck(s), if any, which may be located from time to time within the improvements constructed upon the Hotel Unit. Notwithstanding the designation of the main hotel lobby, the pool(s) and pool deck(s) as part of the Shared Components, the Hotel Unit Owner shall have the right to regulate the use thereof, including, without limitation, establishing hours of operation, and designating certain services offered from those facilities as a la carte. Notwithstanding anything herein, or in any of the exhibits hereto, contained to the contrary, the Shared Components shall be deemed part of the Hotel Unit. The Hotel Unit Owner shall have the right (but not the obligation), by Supplemental Declaration executed by the Hotel Unit Owner alone, to designate additional portions of the Hotel Unit as Shared Components hereunder. Notwithstanding the

designation of the Shared Components, the Hotel Unit Owner shall have the right, from time to time, to expand, alter, relocate and/or eliminate the portions of the Hotel Unit deemed Shared Components (provided that expansion shall not be beyond the Hotel Unit), without requiring the consent or approval of the Association or any Owner, provided that any portions withdrawn are not, in the reasonable opinion of the Hotel Unit Owner essential to the structural integrity of the Residential Units, the provision of utilities and utility services to the Residential Units and/or the provision of legal access. In furtherance of the foregoing, the Hotel Unit Owner also reserves the absolute right at any time, and from time to time, to construct additional facilities within the Hotel Unit and to determine whether same shall be deemed Shared Components. Further, notwithstanding their designation as Shared Components, subject to the right of the Hotel Unit Owner to regulate their uses, the balconies, lanais and/or rooftop terraces directly serving a Unit shall be reserved for the exclusive use of the Unit afforded direct access thereto and that exclusive use right shall be an appurtenance which passes with title to the Unit. Without limiting the generality of the foregoing, any and all food and beverage operations and/or business center(s), whether now or hereafter located upon the Hotel Unit, shall expressly be excluded from the Shared Components and shall be deemed the exclusive property, and for the exclusive use, of the owner from time to time of the Hotel Unit and such persons or entities designated by the Hotel Unit Owner. It is expressly contemplated that persons other than Unit Owners shall be granted use rights in and to certain of the facilities of the Hotel Unit (such determination to be made in the sole and absolute discretion of the Hotel Unit Owner).

- 2.39 "Unit" means a part of the Condominium Property which is subject to exclusive ownership, and except where specifically excluded, or the context otherwise requires, shall be deemed to include the Residential Units and the Hotel Unit.
- 2.40 "Unit Owner" or "Owner of a Unit" or "Owner" means a record owner of legal title to a Condominium Parcel.

3. Description of Condominium.

3.1 Identification of Units. The Realty consists of the Building containing a total of two hundred eighty seven (287) Units, consisting of two hundred eighty six (286) Residential Units and one (1) Hotel Unit. Each such Unit is identified by a separate alpha-numerical designation. The designation of each of such Units is set forth on Exhibit "2" attached hereto. Exhibit "2" consists of a survey of the Realty, a graphic description of the Improvements located thereon, including, but not limited to, the Building in which the Units are located, and a plot plan thereof. Said Exhibit "2", together with this Declaration, is sufficient in detail to identify the Common Elements and each Unit and their relative locations and dimensions. There shall pass with a Unit as appurtenances thereto: (a) an undivided share in the Common Elements and Common Surplus; (b) the exclusive right to use such portion of the Common Elements as may be provided in this Declaration; (c) an exclusive easement for the use of the airspace occupied by the Unit as it exists at any particular time and as the Unit may lawfully be altered or reconstructed from time to time, provided that an easement in airspace which is vacated shall be terminated automatically; (d) membership in the Association with the full voting rights appurtenant thereto; and (e) other appurtenances as may be provided by this Declaration.

3.2 Unit Boundaries. Each Unit shall include that part of the Building containing the Unit that lies within the following boundaries:

- (a) Boundaries of Residential Units. The upper and lower boundaries of each Residential Unit shall be the following boundaries extended to their planar intersections with the perimetrical boundaries:

- (i) Upper Boundaries. The horizontal plane of the unfinished lower surface of the ceiling (which will be deemed to be the ceiling of the upper story if the Unit is a multi-story Residential Unit, provided that in multi-story Residential Units where the lower boundary extends beyond the upper boundary, the upper boundary shall include that portion of the ceiling of the lower floor for which there is no corresponding ceiling on the upper floor directly above such bottom floor ceiling).
 - (ii) Lower Boundaries. The horizontal plane of the unfinished upper surface of the floor of the Residential Unit (which will be deemed to be the floor of the first story if the Unit is a multi-story Residential Unit, provided that in multi-story Residential Units where the upper boundary extends beyond the lower boundary, the lower boundary shall include that portion of the floor of the upper floor for which there is no corresponding floor on the bottom floor directly below the floor of such top floor).
 - (iii) Interior Divisions. Except as provided in subsections 3.2(a)(i) and 3.2(a)(ii) above, no part of the floor of the top floor, ceiling of the bottom floor, stairwell adjoining the multi-floors, in all cases of a multi-story Unit, if any, or nonstructural interior walls shall be considered a boundary of the Residential Unit.
 - (iv) Perimetrical Boundaries. The perimetrical boundaries of the Residential Units shall be the vertical planes of the unfinished interior surfaces of the walls bounding the Unit extended to their planar intersections with each other and with the upper and lower boundaries (and to the extent that the walls are drywall and/or gypsum board, the Residential Unit boundaries shall be deemed to be the area immediately behind the drywall and/or gypsum board, so that for all purposes hereunder the drywall and/or gypsum board shall be deemed part of the Residential Unit, and not part of the Hotel Unit and/or the Common Elements). Notwithstanding the foregoing, as to walls shared by a Residential Unit and the Hotel Unit, the perimetrical boundary of the Hotel Unit at such shared wall shall be coextensive to the perimetrical boundary of the adjoining Residential Unit (so that the shared wall and all installations therein - which are deemed part of the Shared Components - shall be part of the Hotel Unit rather than the Common Elements and therefore the perimetrical boundary of the Hotel Unit shall extend to the unfinished interior surface of any walls bounding a Residential Unit).
- (b) Boundaries of Hotel Unit. The Hotel Unit shall consist of all of the Condominium Property, including, without limitation, any and all Improvements now or hereafter constructed thereon, less and except only the following: (i) the Residential Units, and (ii) the portion of the Condominium Property above elevation 230 feet (230') N.G.V.D. Said portion of the Condominium Property lying above elevation 230.00 feet (230') N.G.V.D. shall be deemed Common Elements hereunder.
- (c) Apertures. Where there are apertures in any boundary, including, but not limited to, windows, doors, bay windows and skylights, all of same shall be deemed part of the Shared Components, and as such, part of the Hotel Unit. **NOTWITHSTANDING ANYTHING HEREIN CONTAINED TO THE CONTRARY, NO POST TENSION CABLES AND/OR RODS CONTAINED IN THE BUILDING SHALL BE CONSIDERED A PART OF THE COMMON ELEMENTS OR A RESIDENTIAL UNIT. AS SUCH POST TENSIONED CABLES AND/OR RODS ARE ESSENTIAL TO THE STRUCTURE AND SUPPORT OF THE BUILDING, ALL POST TENSIONED CABLES AND/OR RODS SHALL BE DEEMED**

SHARED COMPONENTS OF THE HOTEL UNIT AND MAY NOT BE DISTURBED OR ALTERED WITHOUT THE PRIOR WRITTEN CONSENT OF THE HOTEL UNIT OWNER.

- (d) Exceptions. In cases not specifically covered above, and/or in any case of conflict or ambiguity, the survey of the Units set forth as Exhibit "2" hereto shall control in determining the boundaries of a Unit, except that the provisions of Section (b) above shall control unless specifically depicted and labeled otherwise on such survey.
- 3.3 Parking Spaces. All of the parking spaces are located within the Entry/Garage Space subject to the Reciprocal Easement Agreement, and shall be subject to the procedures and regulations established from time to time thereunder.
- 3.4 Easements. The following easements are hereby created (in addition to any easements created under the Act, the easements created in the Reciprocal Easement Agreement and any other easements affecting the Condominium Property and recorded in the Public Records of the County):
- (a) Support. Each Unit and any structure and/or improvement now or hereafter constructed upon the Condominium Property and/or the Easement Parcel shall have an easement of support and of necessity and shall be subject to an easement of support and necessity in favor of all other Units, the Common Elements and such other improvements constructed upon the Condominium Property.
- (b) Utility and Other Services; Drainage. Easements are reserved under, through and over the Condominium Property as may be required from time to time for utility, cable television, communications and monitoring systems, Life Safety Systems, digital and/or satellite systems, broadband communications and other services and drainage in order to serve the Condominium and/or members of the Association and/or the Easement Parcel. A Unit Owner shall do nothing within or outside his or her Unit that interferes with or impairs, or may interfere with or impair, the provision of such utility, cable television, communications monitoring systems, Life Safety Systems, digital and/or satellite systems, broadband communications or other service or drainage facilities or the use of these easements. The Association (as to Common Elements) and Hotel Unit Owner (as to Shared Components) shall have a right of access to each Unit to maintain, repair or replace any Common Element or Shared Component pipes, wires, ducts, vents, cables, conduits and other utility, cable television, communications, Life Safety Systems, digital and/or satellite systems, broadband communications and similar systems, hot water heaters, service and drainage facilities, and Common Elements and/or Shared Components contained in the Unit or elsewhere in or around the Condominium Property, and to remove any Improvements interfering with or impairing such facilities or easements herein reserved; provided such right of access, except in the event of an emergency, shall not unreasonably interfere with the Unit Owner's permitted use of the Unit, and except in the event of an emergency, entry shall be made on not less than one (1) days' notice (which notice shall not, however, be required if the Unit Owner is absent when the giving of notice is attempted).
- (c) Encroachments. If (i) any portion of the Common Elements and/or Shared Components encroaches upon any Unit; (ii) any Unit encroaches upon any other Unit or upon any portion of the Common Elements and/or Shared Components; (iii) any "improvements" of or upon the Easement Parcel encroach upon the Condominium Property; or (iv) any encroachment shall hereafter occur as a result of (1) construction of the Improvements; (2) settling or shifting of the

Improvements; (3) any alteration or repair to the Common Elements (or the Shared Components) made by or with the consent of the Association or Developer or the Hotel Unit Owner, as appropriate; or (4) any repair or restoration of the Improvements (or any portion thereof) or any Unit after damage by fire or other casualty or any taking by condemnation or eminent domain proceedings of all or any portion of any Unit or the Common Elements or the Shared Components, then, in any such event, a valid easement shall exist for such encroachment and for the maintenance of same so long as the Improvements shall stand.

- (d) Ingress and Egress. A non-exclusive easement in favor of each Unit Owner and resident, their guests and invitees, for each member of the Association (and its and their guests, tenants and invitees) shall exist for (i) pedestrian traffic over, through and across such portions of the Hotel Unit as are designated by the Hotel Unit Owner and intended to provide direct pedestrian access to and from the applicable Residential Unit, and (ii) use and enjoyment of the Shared Components, subject to regulation as may be established from time to time by the Hotel Unit Owner and the other provisions of this Declaration. **Notwithstanding the foregoing, the aforesaid easement over the Hotel Unit is limited and solely for use of the named beneficiaries' obtaining access to and from their Residential Unit and shall not be used for the provision of any services, including, without limitation, any Hotel related services including, but not limited to, solicitation and/or provision of maintenance, housekeeping, personal services (i.e., massage, personal training, dry cleaning, etc.) and/or food and beverage service, it being understood and agreed by all Unit Owners that any such services may only be provided by, or arranged through, the Owner(s) of the Hotel Unit (unless otherwise provided by the Hotel Unit Owner). The provisions of this section 3.4(d) may not be amended without an affirmative vote of not less than 4/5ths of all voting interests of all Unit Owners.**
- (e) Construction; Maintenance. The Developer (including its designees, agents, contractors, successors and assigns) and the Hotel Unit Owner (including its designees, agents, contractors, successors and assigns) shall have the right, in its (and their) sole discretion from time to time, to enter the Condominium Property and take all other action necessary or convenient for the purpose of completing the construction of any and all improvements upon any portion of the Condominium Property, or any part thereof and/or any improvements located or to be located upon the Easement Parcel (for so long as any portion of same is owned by the Developer or any affiliate thereof) and for repair, replacement and maintenance or warranty purposes or where the Developer and/or Hotel Unit Owner, in its or their sole discretion, determines that it is required or desires to do so.
- (f) Sales Activity. Until such time as Developer is no longer offering units for sale in the ordinary course of business, the Developer, its designees, successors and assigns, shall have the right to use any Units then owned by the Developer and parts of the Common Elements or Association Property for guest accommodations, model apartments and sales, leasing and construction offices relating to the Condominium, to show model Units and the Common Elements to prospective purchasers and tenants of Units, and to erect on the Condominium Property and/or Association Property signs and other promotional material to advertise or otherwise market the Units, and/or any facilities built or to be constructed upon any portion of the Condominium Property for sale, lease or occupancy (and an easement is hereby reserved for all such purposes).

- (g) Roof and Window Washing Easement. An easement is hereby reserved over and across each Unit and any appurtenances thereto for the Hotel Unit Owner (and the personnel, employees and/or contractors of the Hotel Unit Owner) to stage and perform exterior window washing, exterior painting of the Building, maintenance, repair, replacement or alteration of any mechanical equipment located or accessible from the roof of the Building and/or other exterior repairs, replacements, alterations and/or maintenance (preventative or otherwise).
- (h) Association Maintenance Easement. To the extent that the Association must undertake maintenance responsibilities of the Shared Components in accordance with Section 12.6 herein, then in such event, but only for such remedial actions as may be necessary, the Association shall have a non-exclusive easement of ingress and egress over, under and across the Shared Components.
- (i) Support of Adjacent Structures. In the event that any structure(s) is constructed so as to be connected in any manner to the Buildings and/or any improvements constructed upon the Condominium Property, then there shall be (and there is hereby declared) an easement of support for such structure(s) as well as for the installation, maintenance, repair and replacement of all utility lines and equipment serving the adjoining structures which are necessarily or conveniently located within the Condominium Property and/or the Association Property.
- (j) Warranty. For as long as Developer remains liable under any warranty, whether statutory, express or implied, for acts or omissions of Developer in the development, construction, sale, resale, leasing, financing and marketing of the Condominium, then Developer and its contractors, agents and designees shall have the right, in Developer's sole discretion and from time to time and without requiring prior approval of the Association and/or any Unit Owner and without requiring any consideration to be paid by the Developer to the Unit Owners and/or Condominium Association (provided, however, that absent an emergency situation, Developer shall provide reasonable advance notice), to enter the Condominium Property, including the Units and Common Elements, for the purpose of inspecting, testing and surveying same to determine the need for repairs, improvements and/or replacements, and effecting same, so that Developer can fulfill any of its warranty obligations. The failure of the Association or any Unit Owner to grant, or to interfere with, such access, shall alleviate the Developer from having to fulfill its warranty obligations and the costs, expenses, liabilities or damages arising out of any unfulfilled Developer warranty will be the sole obligation and liability of the person or entity who or which impedes the Developer in any way in Developer's activities described in this Subsection 3.4(j). **The easements reserved in this Section shall expressly survive the transfer of control of the Association to Unit Owners other than the Developer and the issuance of any certificates of occupancy for the Condominium Property (or portions thereof). Nothing herein shall be deemed or construed as the Developer making or offering any warranty, all of which are disclaimed (except to the extent same may not be or are expressly set forth herein) as set forth in Section 23 below.**
- (k) Additional Easements. The Hotel Unit Owner, on behalf of all Unit Owners (each of whom hereby appoints the Hotel Unit Owner as its attorney-in-fact for this purpose), shall have the right to grant such additional general ("blanket") and specific electric, gas or other utility, cable television, security systems, communications or service easements (and appropriate bills of sale for equipment, conduits, pipes, lines and similar installations pertaining thereto), or modify or relocate any such existing easements or drainage facilities, in any portion of the Condominium and/or Association Property, and to grant access easements or

relocate any existing access easements in any portion of the Condominium and/or Association Property, as the Hotel Unit Owner shall deem necessary or desirable for the proper operation and maintenance of the Improvements, or any portion thereof, or for the general health or welfare of the Unit Owners and/or members of the Association, or for the purpose of carrying out any provisions of this Declaration, provided that such easements or the relocation of existing easements will not prevent or unreasonably interfere with the reasonable use of the Units for their intended purposes.

4. Restraint Upon Separation and Partition of Common Elements. The undivided share in the Common Elements and Common Surplus which is appurtenant to a Unit, shall not be separated therefrom and shall pass with the title to the Unit, whether or not separately described. The appurtenant share in the Common Elements and Common Surplus, except as elsewhere herein provided to the contrary, cannot be conveyed or encumbered except together with the Unit. The respective shares in the Common Elements appurtenant to Units shall remain undivided, and no action for partition of the Common Elements, the Condominium Property, or any part thereof, shall lie, except as provided herein with respect to termination of the Condominium.
5. Ownership of Common Elements and Common Surplus and Share of Common Expenses; Voting Rights
 - 5.1 Percentage Ownership and Shares. The undivided percentage interest in the Common Elements and Common Surplus, and the percentage share of the Common Expenses, appurtenant to each Unit, is based upon the total square footage of each Unit in uniform relationship to the total square footage of each other Unit, and is as set forth on **Exhibit "3"** attached hereto (the "Allocated Interests").
 - 5.2 Voting. Each Residential Unit shall be entitled to one (1) vote to be cast by its Owner in accordance with the provisions of the By-Laws and Articles of Incorporation of the Association. The Hotel Unit shall be entitled to one hundred twenty five (125) votes to be cast by its Owner in accordance with the provisions of the By-Laws and Articles of Incorporation of the Association. Each Unit Owner shall be a member of the Association.
6. Amendments. Except as elsewhere provided herein, amendments to this Declaration may be effected as follows:
 - 6.1 By The Association. Notice of the subject matter of a proposed amendment shall be included in the notice of any meeting at which a proposed amendment is to be considered. A resolution for the adoption of a proposed amendment may be proposed either by a majority of the Board of Directors of the Association or by not less than one-third (1/3) of the Unit Owners. Except as elsewhere provided, approvals must be by an affirmative vote representing in excess of sixty six and two thirds percent (66 2/3%) of the voting interests of all Unit Owners. Directors and members not present in person or by proxy at the meeting considering the amendment may express their approval in writing, provided that such approval is delivered to the secretary at or prior to the meeting, however, such approval or disapproval may not be used as a vote for or against the action taken and may not be used for the purpose of creating a quorum.
 - 6.2 Material Amendments. Unless otherwise provided specifically to the contrary in this Declaration, no amendment shall change the configuration or size of any Unit in any material fashion, materially alter or modify the appurtenances to any Unit, permit timeshare estates, or change the percentage by which the Owner of a Unit shares the Common Expenses and owns the Common Elements and Common Surplus (any such change or alteration being a "Material Amendment"), unless the record Owner(s) thereof, and all

record owners of mortgages or other liens thereon, shall join in the execution of the amendment and the amendment is otherwise approved by in excess of eighty percent (80%) of the voting interests of Unit Owners. The acquisition of property by the Association, material alterations or substantial additions to such property or the Common Elements by the Association and installation, replacement and maintenance of approved exterior storm shutters, if in accordance with the provisions of this Declaration, shall not be deemed to constitute a material alteration or modification of the appurtenances of the Units, and accordingly, shall not constitute a Material Amendment.

- 6.3 Mortgagee's Consent. No amendment may be adopted which would eliminate, modify, prejudice, abridge or otherwise adversely affect any rights, benefits, privileges or priorities granted or reserved to mortgagees of Units without the consent of said mortgagees in each instance; nor shall an amendment make any change in the sections hereof entitled "Insurance", "Reconstruction or Repair after Casualty", or "Condemnation" unless the Primary Institutional First Mortgagee shall join in the amendment. Except as specifically provided herein or if required by FNMA or FHLMC, the consent and/or joinder of any lien or mortgage holder on a Unit shall not be required for the adoption of an amendment to this Declaration and, whenever the consent or joinder of a lien or mortgage holder is required, such consent or joinder shall not be unreasonably withheld.
- 6.4 By or Affecting The Developer. Notwithstanding anything herein contained to the contrary, during the time the Developer has the right to elect a majority of the Board of Directors of the Association, the Declaration, the Articles of Incorporation or the By-Laws of the Association may be amended by the Developer alone, without requiring the consent of any other party, to effect any change whatsoever, except for an amendment: (a) to permit time-share estates (which must be approved, if at all, in the manner provided in Section 6.2 above); or (b) to effect a "Material Amendment", which must be approved, if at all, in the manner set forth in Section 6.2 above. The unilateral amendment right set forth herein shall include, without limitation, the right to correct scrivener's errors. No amendment may be adopted which would eliminate, modify, prejudice, abridge or otherwise adversely affect any rights, benefits, privileges or priorities granted or reserved to the Developer, without the consent of the Developer in each instance.
- 6.5 Amendments affecting Hotel Unit. No amendment may be adopted which would eliminate, modify, prejudice, abridge or otherwise adversely affect any rights, benefits, privileges or priorities granted or reserved to the Owner(s) from time to time of the Hotel Unit, without the consent of the applicable Unit Owner(s) in each instance.
- 6.6 Execution and Recording. An amendment, other than amendments made by the Developer alone pursuant to the Act or this Declaration, shall be evidenced by a certificate of the Association, executed either by the President of the Association or a majority of the members of the Board of Directors which shall include recording data identifying the Declaration and shall be executed with the same formalities required for the execution of a deed. An amendment of the Declaration is effective when the applicable amendment is properly recorded in the public records of the County. No provision of this Declaration shall be revised or amended by reference to its title or number only. Proposals to amend existing provisions of this Declaration shall contain the full text of the provision to be amended; new words shall be inserted in the text underlined; and words to be deleted shall be lined through with hyphens. However, if the proposed change is so extensive that this procedure would hinder, rather than assist, the understanding of the proposed amendment, it is not necessary to use underlining and hyphens as indicators of words added or deleted, but, instead, a notation must be inserted immediately preceding the proposed amendment in substantially the following language: "Substantial rewording of Declaration. See provision . . . for present text." Nonmaterial errors or omissions in the amendment process shall not invalidate an otherwise properly adopted amendment.

7. Maintenance and Repairs.

- 7.1 Units. All maintenance, repairs and replacements of, in or to any Unit, whether structural or nonstructural, ordinary or extraordinary, foreseen or unforeseen, including, without limitation, maintenance, repair and replacement of windows, window coverings, interior nonstructural walls, the interior side of the entrance door and all other doors within or affording access to a Unit, and the electrical (including wiring), plumbing (including fixtures and connections), heating and air-conditioning equipment, fixtures and outlets, appliances, carpets and other floor coverings, all interior surfaces and the entire interior of the Unit lying within the boundaries of the Unit or other property belonging to the Unit Owner, shall be performed by the Owner of such Unit at the Unit Owner's sole cost and expense, except as otherwise expressly provided to the contrary herein. Notwithstanding anything herein to the contrary, to the extent that any of the foregoing items are part of the Shared Components, then the maintenance of same shall be the obligation of the Hotel Unit Owner, with the costs thereof charged against the Unit Owners in accordance with the terms of Section 12 of this Declaration.
- 7.2 Common Elements and Association Property. Except to the extent (i) expressly provided to the contrary herein, or (ii) proceeds of insurance are made available therefor, all maintenance, repairs and replacements in or to the Common Elements and Association Property shall be performed by the Association and the cost and expense thereof shall be charged to all Unit Owners as a Common Expense, except to the extent arising from or necessitated by the negligence, misuse or neglect of specific Unit Owners, in which case such cost and expense shall be paid solely by such Unit Owners.
- 7.3 Hotel Unit. The Hotel Unit Owner(s), from time to time, shall be responsible for the repair, replacement, improvement, maintenance, management, operation, and insurance of the Hotel Unit, which shall be performed in a commercially reasonable manner in the determination of the Owner(s) of the Hotel Unit (which determination shall be binding). In consideration of the reservation and grant of easement over the Hotel Unit, as provided in Section 3.4(d) above, each Residential Unit Owner shall be obligated for payment of the expenses incurred by the Hotel Unit Owner(s) in connection with such maintenance, repair, replacement, improvement, management, operation, and insurance, all as more particularly provided in Section 12 below. Notwithstanding the duty of the Hotel Unit Owner to maintain and repair parts of the Condominium Property, the Hotel Unit Owner shall not be liable to Unit Owners for injury or damage, other than for the cost of maintenance and repair, caused by any latent condition of the Condominium Property. Further, the Hotel Unit Owner shall not be liable for any such injury or damage caused by defects in design or workmanship or any other reason connected with any additions, alterations or improvements or other activities done by or on behalf of any Unit Owners regardless of whether or not same shall have been approved by the Hotel Unit Owner pursuant to Section 8.1 hereof. The Hotel Unit Owner also shall not be liable to any Unit Owner or lessee or to any other person or entity for any property damage, personal injury, death or other liability on the grounds that the Hotel Unit Owner did not obtain or maintain insurance (or carried insurance with any particular deductible amount) for any particular matter where: (i) such insurance is not required hereby; or (ii) the Hotel Unit Owner could not obtain such insurance at reasonable costs or upon reasonable terms.
- 7.4 Specific Unit Owner Responsibility. The obligation to maintain and repair any air conditioning equipment, plumbing or electrical fixtures or other items of property which service a particular Unit and not any other Unit shall, to the extent not part of the Shared Components and otherwise part of the Condominium, be the responsibility of the applicable Unit Owner, individually, without regard to whether such items are included within the boundaries of the Units.

7.5 Standards for Maintenance. Notwithstanding anything herein contained to the contrary, any and all maintenance obligations of either the Association or a Unit Owner must be undertaken in such a manner to assure that the portions being maintained by the Association, and/or any Unit Owner are consistent with the standards of any hotel operated from within the Hotel Unit (the "Hotel") and the other hotels and resorts owned or managed and operated by the operator of the Hotel, or its affiliates.

8. Additions, Alterations or Improvements by Unit Owner.

8.1 Consent of the Hotel Unit Owner No Residential Unit Owner (other than the Developer) shall (i) make any addition, alteration or improvement in or to the Common Elements, the Association Property, or his or her Unit, (ii) install any signage in or on the Unit, or upon the Common Elements, Association Property or the Shared Components and/or (iii) make any addition, alteration or improvement affecting any electrical, mechanical, HVAC, plumbing, life safety, monitoring, information and/or other systems of the Building, without the prior written consent of the Hotel Unit Owner. The Hotel Unit Owner shall have the obligation to answer, in writing, any written request by a Residential Unit Owner for approval of such an addition, alteration or improvement within thirty (30) days after such request and all additional information requested is received, and the failure to do so within the stipulated time shall constitute the Hotel Unit Owner's consent. The Hotel Unit Owner may condition the approval in any manner, including, without limitation, retaining approval rights of the contractor to perform the work, restricting the hours during which the work may be performed and requiring a bond or other collateral to secure the timely completion of the repairs and/or alterations and to offset any liability that may be suffered by the Hotel Unit Owner or any other Unit Owner as a result of such repairs and/or alterations. The proposed additions, alterations and improvements by the Unit Owners shall be made in compliance with all laws, rules, ordinances and regulations of all governmental authorities having jurisdiction, and with any conditions imposed by the Hotel Unit Owner with respect to design, structural integrity, aesthetic appeal, construction details, lien protection or otherwise. Further, no alteration, addition or modification may in any manner affect the Hotel Unit or any portion of the Shared Components, without the prior written consent of the Hotel Unit Owner (which consent may be withheld in its sole discretion). Once approved by the Hotel Unit Owner, such approval may not be revoked. A Residential Unit Owner making or causing to be made any such additions, alterations or improvements agrees, and shall be deemed to have agreed, for such Owner, and such Owner's heirs, personal representatives, successors and assigns, as appropriate, to hold the Association, the Developer, the Hotel Unit Owner and all other Unit Owners and their respective officers, directors, employees, managers, agents, contractors, consultants or attorneys harmless from and to indemnify them for any liability or damage to the Condominium Property, Association Property, the Hotel Unit and/or the Shared Components and expenses arising therefrom, and shall be solely responsible for the maintenance, repair and insurance thereof from and after that date of installation or construction thereof. The Hotel Unit Owner's rights of review and approval of plans and other submissions under this Declaration are intended solely for the benefit of the Hotel Unit Owner. Neither the Developer, the Association, the Hotel Unit Owner, nor any of its officers, directors, employees, managers, agents, contractors, consultants or attorneys shall be liable to any Owner or any other person by reason of mistake in judgment, failure to point out or correct deficiencies in any plans or other submissions, negligence, or any other misfeasance, malfeasance or non-feasance arising out of or in connection with the approval or disapproval of any plans or submissions. Anyone submitting plans hereunder, by the submission of same, and any Owner, by acquiring title to same, agrees not to seek damages from the Developer, the Association and/or the Hotel Unit Owner arising out of the Hotel Unit Owner's review of any plans hereunder. Without limiting the generality of the foregoing, the Hotel Unit Owner shall not be responsible for reviewing, nor shall its review of any plans be deemed approval of, any plans from the standpoint of structural

safety, soundness, workmanship, materials, usefulness, conformity with building or other codes or industry standards, or compliance with governmental requirements. Further, each Owner (including the successors and assigns) agrees to indemnify and hold the Developer, the Association and the Hotel Unit Owner and their respective officers, directors, employees, managers, agents, contractors, consultants, or attorneys harmless from and against any and all costs, claims (whether rightfully or wrongfully asserted), damages, expenses or liabilities whatsoever (including, without limitation, reasonable attorneys' fees and court costs at all trial and appellate levels), arising out of any review of plans hereunder. The foregoing provisions requiring approval shall not be applicable to the Hotel Unit and/or to any Unit owned by the Developer. The provisions of this Section 8.1 shall not be amended without an affirmative vote of 4/5ths of the total voting interests in the Condominium.

Without limiting the generality of the foregoing, to the extent that the Condominium has been constructed with post tensioned cables and/or rods, absolutely no penetration shall be made to any floor, roof or ceiling slabs without the prior written consent of the Hotel Unit Owner and review of the as-built plans and specifications for the Building to confirm the approximate location of the post tensioned cables and/or rods. The plans and specifications for the Building shall be maintained by the Hotel Unit Owner and the Association as part of the official records. Each Unit Owner, by accepting a deed or otherwise acquiring an interest in a Unit shall be deemed to: (i) have assumed the risks associated with post tension construction, and (ii) agree that the penetration of any post tensioned cables and/or rods may threaten the structural integrity of the Building. Each Owner hereby releases Developer and the Hotel Unit Owner, and its and their members, contractors, architects, engineers, and its and their officers, directors, shareholders, employees and agents from and against any and all liability that may result from penetration of any of the post tensioned cables and/or rods.

- 8.2 Life Safety Systems. No Unit Owner shall make any additions, alterations or improvements to the Life Safety Systems, and/or to any other portion of the Condominium Property which may impair the Life Safety Systems or access to the Life Safety Systems, without first receiving the prior written approval of the Hotel Unit Owner. In that regard, no lock, chain or other device or combination thereof shall be installed or maintained at any time on or in connection with any door on which panic hardware or fire exit hardware is required. Stairwell identification and emergency signage shall not be altered or removed by any Unit Owner whatsoever. No barrier including, but not limited to personalty, shall impede the free movement of ingress and egress to and from all emergency ingress and egress passageways.
- 8.3 Improvements, Additions or Alterations by Developer or to the Hotel Unit. Anything to the contrary notwithstanding, the foregoing restrictions of this Section 8 shall not apply to Developer-owned Units, nor to the Hotel Unit. The Developer shall have the additional right, without the consent or approval of the Board of Directors or other Unit Owners, but without obligation, to (a) make alterations, additions or improvements, structural and non-structural, interior and exterior, ordinary and extraordinary, in, to and upon any Unit owned by it (including, without limitation, the removal of walls, floors, ceilings and other structural portions of the Improvements), and (b) expand, alter or add to all or any part of the recreational facilities. Similarly, the Hotel Unit Owner shall have the additional right, without the consent or approval of the Board of Directors or other Unit Owners, but without obligation, to make alterations, additions or improvements, structural and non-structural, interior and exterior, ordinary and extraordinary, in, to and upon the Hotel Unit and any portions thereof (including, without limitation, the removal of walls, floors, ceilings and other structural portions of the Improvements), and to expand, alter or add to all or any part of the recreational facilities contained within the Hotel Unit. Any amendment to this Declaration required by a change made pursuant to this Section 8.3 shall be adopted in accordance with Section 6, provided, however, that the exercise of any right by Developer

pursuant to clause (b) above shall not be deemed a Material Amendment. Notwithstanding anything to the contrary contained in this Declaration, each Unit Owner recognizes and agrees that the Hotel Unit Owner shall be permitted to make the following alterations to each Unit (and shall be permitted access to each Unit for purposes of making the following described alterations): (i) installation of unit location/exiting maps on the interior portion of each Residential Unit's entry door and (ii) replacement of manually operated doors with doors containing automatic closing devices (i.e., spring hinges or door closers). To the extent that the Unit Owner has installed unit location/exit maps and/or automatic doors, no Unit Owner shall be permitted to make any additions, alterations or improvements to such unit location/exit maps and/or automatic doors, and/or to any other portion of the Condominium Property which may impair such unit location/exit maps and/or automatic doors, without first receiving the prior written approval of the Board and/or the Hotel Unit Owner.

9. Operation of the Condominium by the Association; Powers and Duties.

9.1 Powers and Duties. The Association shall be the entity responsible for the operation of the Common Elements and the Association Property, but not the Shared Components, as same are part of the Hotel Unit. The powers and duties of the Association shall include those set forth in the By-Laws and Articles of Incorporation of the Association (which By-Laws and Articles are attached hereto as Exhibits "4" and "5", respectively) as amended from time to time. The affairs of the Association shall be governed by a Board of not less than three (3) nor more than nine (9) Directors. In addition, the Association shall have all the powers and duties set forth in the Act, as well as all powers and duties granted to or imposed upon it by this Declaration, including, without limitation:

- (a) The irrevocable right to have access to each Unit from time to time during reasonable hours as may be necessary for pest control purposes and for the maintenance, repair or replacement of any Common Elements or any portion of a Unit, if any, to be maintained by the Association, or at any time and by force, if necessary, to prevent damage to the Common Elements, the Association Property or to a Unit or Units.
- (b) The power to make and collect Assessments and other charges by the Association against Unit Owners and to lease, maintain, repair and replace the Common Elements and Association Property.
- (c) The power to act as the collection agent on behalf, and at the request, of the Hotel Unit Owner for charges due same from Unit Owners; provided, however, that any sums so collected shall not be deemed Assessments or Common Expenses hereunder.
- (d) The duty to maintain accounting records of the Association according to good accounting practices, which shall be open to inspection by Unit Owners or their authorized representatives at reasonable times upon prior request.
- (e) The power to borrow money, execute promissory notes and other evidences of indebtedness and to give as security therefor mortgages and security interests in property owned by the Association, if any, provided that such actions are approved by a majority of the entire membership of the Board of Directors and four-fifths of all voting interests of the Units represented at a meeting at which a quorum has been attained, or by such greater percentage of the Board or Unit Owners as may be specified in the By-Laws with respect to certain borrowing.
- (f) The power to adopt and amend rules and regulations concerning the details of the operation and use of the Common Elements and Association Property.

Notwithstanding anything herein contained to the contrary, no such rule may restrict, limit or otherwise impair the rights of the Hotel Unit Owner and/or the Developer without the prior written consent of the Hotel Unit Owner and/or the Developer, as applicable.

- (g) The power to acquire, convey, lease and encumber real and personal property. Personal property shall be acquired, conveyed, leased or encumbered upon a majority vote of the Board of Directors, unless the cost thereof exceeds \$25,000.00 in which event the acquisition shall require an affirmative vote of not less than four-fifths (4/5th) of all voting interests. Real property shall be acquired, conveyed, leased or encumbered upon a majority vote of the Board of Directors alone and an affirmative vote of not less than four-fifths of all voting interests; provided, however, that the acquisition of any Unit as a result of a foreclosure of the lien for Assessments (or by deed in lieu of foreclosure) shall be made upon the majority vote of the Board, regardless of the price for same and the Association, through its Board, has the power to hold, lease, mortgage or convey the acquired Unit(s) without requiring the consent of Unit Owners. The expenses of ownership (including the expense of making and carrying any mortgage related to such ownership), rental, membership fees, taxes, Assessments, operation, replacements and other expenses and undertakings in connection therewith shall be Common Expenses.
- (h) All of the powers which a corporation not for profit in the State of Florida may exercise pursuant to this Declaration, the Articles of Incorporation, the Bylaws, Chapters 607 and 617, Florida Statutes and the Act, in all cases except as expressly limited or restricted in the Act.

In the event of conflict among the powers and duties of the Association or the terms and provisions of this Declaration, exhibits attached hereto or otherwise, this Declaration shall take precedence over the Articles of Incorporation, By-Laws and applicable rules and regulations; the Articles of Incorporation shall take precedence over the By-Laws and applicable rules and regulations; and the By-Laws shall take precedence over applicable rules and regulations, all as amended from time to time.

- 9.2 Restraint Upon Assignment of Shares in Assets. The share of a Unit Owner in the funds and assets of the Association cannot be assigned, hypothecated or transferred in any manner except as an appurtenance to his Unit.
- 9.3 Approval or Disapproval of Matters. Whenever the decision of a Unit Owner is required upon any matter, whether or not the subject of an Association meeting, that decision shall be expressed by the same person who would cast the vote for that Unit if at an Association meeting, unless the joinder of all record Owners of the Unit is specifically required by this Declaration or by law.
- 9.4 Acts of the Association. Unless the approval or action of Unit Owners, and/or a certain specific percentage of the Board of Directors of the Association, is specifically required in this Declaration, the Articles of Incorporation or By-Laws of the Association, applicable rules and regulations or applicable law, all approvals or actions required or permitted to be given or taken by the Association shall be given or taken by the Board of Directors, without the consent of Unit Owners, and the Board may so approve and act through the proper officers of the Association without a specific resolution. When an approval or action of the Association is permitted to be given or taken hereunder or thereunder, such action or approval may be conditioned in any manner the Association deems appropriate or the Association may refuse to take or give such action or approval without the necessity of establishing the reasonableness of such conditions or refusal.

- 9.5 Effect on Developer. If the Developer holds a Unit for sale in the ordinary course of business, none of the following actions may be taken by the Association, subsequent to the transfer of control of the Board to Unit Owners other than the Developer, without the prior written approval of the Developer:
- (a) Assessment of the Developer as a Unit Owner for capital improvements;
 - (b) Any action by the Association that would be detrimental to the sales of Units by the Developer; provided, however, that an increase in Assessments for Common Expenses without discrimination against the Developer shall not be deemed to be detrimental to the sales of Units.
10. Determination of Common Expenses and Fixing of Assessments Therefor. The Board of Directors shall from time to time, and at least annually, prepare a budget for the Condominium and the Association, determine the amount of Assessments payable by the Unit Owners to meet the Common Expenses of the Condominium and allocate and assess such expenses among the Unit Owners in accordance with the provisions of this Declaration and the By-Laws. The Board of Directors shall advise all Unit Owners promptly in writing of the amount of the Assessments payable by each of them as determined by the Board of Directors as aforesaid and shall furnish copies of the budget, on which such Assessments are based, to all Unit Owners and (if requested in writing) to their respective mortgagees. The Common Expenses shall include the expenses of and reserves for (if required by, and not waived in accordance with, applicable law) the operation, maintenance, repair and replacement of the Common Elements and Association Property, costs of carrying out the powers and duties of the Association and any other expenses designated as Common Expenses by the Act, this Declaration, the Articles or By-Laws of the Association, applicable rules and regulations or by the Association. Incidental income to the Association, if any, may be used to pay regular or extraordinary Association expenses and liabilities, to fund reserve accounts, or otherwise as the Board shall determine from time to time, and need not be restricted or accumulated. Any Budget adopted shall be subject to change to cover actual expenses at any time. Any such change shall be adopted consistent with the provisions of this Declaration and the By-Laws.
11. Collection of Assessments.
- 11.1 Liability for Assessments. A Unit Owner, regardless of how title is acquired, including by purchase at a foreclosure sale or by deed in lieu of foreclosure shall be liable for all Assessments coming due while he or she is the Unit Owner. Additionally, a Unit Owner shall be jointly and severally liable with the previous Owner for all unpaid Assessments that came due up to the time of the conveyance, without prejudice to any right the Owner may have to recover from the previous Owner the amounts paid by the grantee Owner. The liability for Assessments may not be avoided by waiver of the use or enjoyment of any Common Elements or by the abandonment of the Unit for which the Assessments are made or otherwise.
- 11.2 Special and Capital Improvement Assessments. In addition to Assessments levied by the Association to meet the Common Expenses of the Condominium and the Association, the Board of Directors may levy "Special Assessments" and "Capital Improvement Assessments" upon the following terms and conditions:
- (a) "Special Assessments" shall mean and refer to an Assessment against each Owner and his Unit, representing a portion of the costs incurred by the Association for specific purposes of a nonrecurring nature which are not in the nature of capital improvements.

- (b) "Capital Improvement Assessments" shall mean and refer to an Assessment against each Owner and his Unit, representing a portion of the costs incurred by the Association for the acquisition, installation, construction or replacement (as distinguished from repairs and maintenance) of any capital improvements located or to be located within the Common Elements or Association Property.
- (c) Special Assessments and Capital Improvement Assessments may be levied by the Board and shall be payable in lump sums or installments, in the discretion of the Board; provided that, if such Special Assessments or Capital Improvement Assessments, in the aggregate in any year, exceed \$125,000.00 or cause the total Assessments levied to exceed 115% of Assessments for the preceding calendar year, the Board must obtain approval of a majority of the Units represented at a meeting at which a quorum is attained.

11.3 Default in Payment of Assessments for Common Expenses. Assessments and installments thereof not paid within ten (10) days from the date when they are due shall bear interest at fifteen percent (15%) per annum from the date due until paid and shall be subject to an administrative late fee in an amount not to exceed the greater of \$25.00 or five percent (5%) of each delinquent installment. The Association has a lien on each Condominium Parcel to secure the payment of Assessments. Except as set forth below, the lien is effective from, and shall relate back to, the date of the recording of this Declaration. However, as to first mortgages of record, the lien is effective from and after the date of the recording of a claim of lien in the Public Records of the County, stating the description of the Condominium Parcel, the name of the record Owner and the name and address of the Association. The lien shall be evidenced by the recording of a claim of lien in the Public Records of the County. To be valid, the claim of lien must state the description of the Condominium Parcel, the name of the record Owner, the name and address of the Association, the amount due and the due dates, and the claim of lien must be executed and acknowledged by an officer or authorized officer of the Association. The claim of lien shall not be released until all sums secured by it (or such other amount as to which the Association shall agree by way of settlement) have been fully paid or until it is barred by law. No such lien shall be effective longer than one (1) year after the claim of lien has been recorded unless, within that one (1) year period, an action to enforce the lien is commenced. The one (1) year period shall automatically be extended for any length of time during which the Association is prevented from filing a foreclosure action by an automatic stay resulting from a bankruptcy petition filed by the Owner or any other person claiming an interest in the Unit. The claim of lien shall secure (whether or not stated therein) all unpaid Assessments, which are due and which may accrue subsequent to the recording of the claim of lien and prior to the entry of a certificate of title, as well as interest and all reasonable costs and attorneys' fees incurred by the Association incident to the collection process. Upon payment in full, the person making the payment is entitled to a satisfaction of the lien in recordable form. The Association may bring an action in its name to foreclose a lien for unpaid Assessments in the manner a mortgage of real property is foreclosed and may also bring an action at law to recover a money judgment for the unpaid Assessments without waiving any claim of lien. The Association is entitled to recover its reasonable attorneys' fees incurred either in a lien foreclosure action or an action to recover a money judgment for unpaid Assessments.

As an additional right and remedy of the Association, upon default in the payment of Assessments as aforesaid and after thirty (30) days' prior written notice to the applicable Unit Owner and the recording of a claim of lien, the Association may declare the Assessment installments for the remainder of the budget year to be accelerated and immediately due and payable. In the event that the amount of such installments changes during the remainder of the budget year, the Unit Owner or the Association, as appropriate, shall be obligated to pay or reimburse to the other the amount of increase or decrease within ten (10) days of same taking effect.

- 11.4 Notice of Intention to Foreclose Lien. No foreclosure judgment may be entered until at least thirty (30) days after the Association gives written notice to the Unit Owner of its intention to foreclose its lien to collect the unpaid Assessments. If this notice is not given at least thirty (30) days before the foreclosure action is filed, and if the unpaid Assessments, including those coming due after the claim of lien is recorded, are paid before the entry of a final judgment of foreclosure, the Association shall not recover attorney's fees or costs. The notice must be given by delivery of a copy of it to the Unit Owner or by certified or registered mail, return receipt requested, addressed to the Unit Owner at the last known address, and upon such mailing, the notice shall be deemed to have been given. If after diligent search and inquiry the Association cannot find the Unit Owner or a mailing address at which the Unit Owner will receive the notice, the court may proceed with the foreclosure action and may award attorney's fees and costs as permitted by law. The notice requirements of this subsection are satisfied if the Unit Owner records a Notice of Contest of Lien as provided in the Act.
- 11.5 Appointment of Receiver to Collect Rental. If the Unit Owner remains in possession of the Unit after a foreclosure judgment has been entered, the court in its discretion may require the Unit Owner to pay a reasonable rental for the Unit. If the Unit is rented or leased during the pendency of the foreclosure action, the Association is entitled to the appointment of a receiver to collect the rent. The expenses of such receiver shall be paid by the party which does not prevail in the foreclosure action.
- 11.6 First Mortgagee. The liability of a First Mortgagee, or its successor or assignees, who acquire title to a Unit by foreclosure or by deed in lieu of foreclosure for the unpaid Assessments (or installments thereof) that became due prior to the First Mortgagee's acquisition of title is limited to the lesser of:
- (a) The Unit's unpaid Common Expenses and regular periodic Assessments which accrued or came due during the six (6) months immediately preceding the acquisition of title and for which payment in full has not been received by the Association; or
 - (b) One percent (1%) of the original mortgage debt.

As to a Unit acquired by foreclosure, the limitations set forth in clauses (a) and (b) above shall not apply unless the First Mortgagee joined the Association as a defendant in the foreclosure action. Joinder of the Association, however, is not required if, on the date the complaint is filed, the Association was dissolved or did not maintain an office or agent for service of process at a location which was known to or reasonably discoverable by the mortgagee.

A First Mortgagee acquiring title to a Unit as a result of foreclosure or deed in lieu thereof may not, during the period of its ownership of such Unit, whether or not such Unit is unoccupied, be excused from the payment of some or all of the Common Expenses coming due during the period of such ownership.

- 11.7 Developer's Liability for Assessments. During the period from the date of the recording of this Declaration until the earlier of the following dates (the "Guarantee Expiration Date"): (a) the last day of the sixth (6th) complete calendar month after the applicable recording date, or (b) the date that control of the Association is transferred to Unit Owners other than the Developer as provided in the By-Laws and the Act, the Developer shall not be obligated to pay the share of Common Expenses and Assessments attributable to the Units owned by the Developer, provided: (i) that the regular Assessments for Common Expenses imposed on each Unit Owner other than the Developer prior to the Guarantee Expiration Date shall not increase during such period over the amount set forth in Exhibit "6" attached hereto, subject only to the occurrence of an Extraordinary Financial Event, as

set forth below; and (ii) that the Developer shall be obligated to pay any amount of Common Expenses actually incurred during such period and not produced by the Assessments at the guaranteed levels receivable from other Unit Owners and/or from income of the Association. After the Guarantee Expiration Date, the Developer shall have the option of extending the guarantee for four (4) additional six (6) month periods, or paying the share of Common Expenses and Assessments attributable to Units it then owns. Notwithstanding the above and as provided in Section 718.116(9)(a)(2) of the Act, in the event of an Extraordinary Financial Event (as hereinafter defined), the costs necessary to effect restoration shall be assessed against all Unit Owners owning units on the date of such Extraordinary Financial Event, and their successors and assigns, including the Developer (with respect to Units owned by the Developer). As used in this subsection, an "Extraordinary Financial Event" shall mean a casualty loss affecting the Condominium resulting from a natural disaster or Act of God, which is not covered by insurance proceeds from the insurance maintained by the Association as required by Section 718.111(11)(a) of the Act.

- 11.8 Certificate of Unpaid Assessments. Within fifteen (15) days after written request by a Unit Owner or mortgagee of a Unit, the Association shall provide a certificate stating all Assessments and other moneys owed to the Association by the Unit Owner with respect to his Unit. Any person other than the Unit Owner who relies upon such certificate shall be protected thereby. The Association or its authorized agent may charge a reasonable fee for the preparation of such certificate.
- 11.9 Installments. Regular Assessments shall be collected monthly or quarterly, in advance, at the option of the Association. Initially, Assessments will be collected monthly.
- 11.10 Application of Payments. Any payments received by the Association from a delinquent Unit Owner shall be applied first to any interest accrued on the delinquent installment(s) as aforesaid, then to any administrative late fees, then to any costs and reasonable attorneys' fees incurred in collection and then to the delinquent and any accelerated Assessments. The foregoing shall be applicable notwithstanding any restrictive endorsement, designation or instruction placed on or accompanying a payment.

12. Obligation for Expenses Relating to the Hotel Unit.

- 12.1 Maintenance. As provided in Sections 3.4(d) and 7.3 above, the Hotel Unit Owner has granted easements with respect to certain portions of the Hotel Unit and agreed to repair, replace, improve, maintain, manage, operate, and insure the Hotel Unit, all to be done as determined and ordered by the Hotel Unit Owner, or otherwise as provided in Section 7.3. In consideration of the foregoing, each Residential Unit Owner, by acceptance of a deed or other conveyance of a Residential Unit, and whether or not expressly stated, shall be deemed to agree that the costs incurred by the Hotel Unit Owner in (or reasonably allocated to) the repair, replacement, improvement, maintenance, management (including a commercially reasonable management fee), operation, ad valorem tax obligations and insurance of the Shared Components (including reasonable reserves if established by the Hotel Unit Owner and any assessments payable by the Hotel Unit Owner to the Association, collectively, the "Hotel Shared Costs") shall be paid for in part through charges (either general or special) imposed against the Residential Units in accordance with the terms hereof. The Hotel Shared Costs shall also include the following: (a) the costs and expenses, if any, of installing, maintaining, repairing, restoring, renourishing and/or replacing of the beach/dune systems, and crosswalk or crossover structures to and from the beach located across from (even though beyond the legal boundaries of) the Condominium Property; and (b) the costs and expenses, if any, of providing services to Owners (and their guests, tenants and invitees) on the beach located across from (even though beyond the legal boundaries of) the Condominium Property (without imposing any

obligation on the Developer and/or Association to provide such services). No Owner may waive or otherwise escape liability for charges for the Hotel Shared Costs by non-use (whether voluntary or involuntary) of the Hotel Unit or abandonment of the right to use same. Notwithstanding anything herein contained to the contrary, the Hotel Unit Owner shall be excused and relieved from any and all maintenance, repair and/or replacement obligations with respect to the Hotel Unit to the extent that the funds necessary to perform same, to the extent the obligation of the Residential Unit Owners, are not available through the charges imposed and actually collected. The Hotel Unit Owner shall have no obligation to fund and/or advance any deficit or shortfall in funds which were the obligation of the Residential Unit Owners in order to properly perform the maintenance, repair and/or replacement obligations described herein.

- 12.2 Easement. An easement is hereby reserved and created in favor of the Hotel Unit Owner, and its designees over the Condominium Property for the purpose of entering onto the Condominium Property for the performance of the maintenance, repair and replacement obligations herein described. Without limiting the generality of the foregoing, each Owner shall be deemed to understand and agree that inasmuch as the Condominium Property does not contain trash chutes, the Owner shall be obligated to follow such trash removal procedures as may be established from time to time by the Hotel Unit Owner. To the extent that the Hotel Unit Owner determines (without any obligation to do so) to remove trash directly from each Unit, then: (i) an easement is hereby reserved to allow the Hotel Unit Owner (or its employees, agents or contractors) access to each Unit for such purpose, and (ii) all costs in connection with trash removal shall be deemed part of the Hotel Shared Costs.
- 12.3 Charges to Residential Unit Owners; Lien. Developer, for all Units now or hereafter located within the Condominium Property, hereby covenants and agrees, and each Owner of any Residential Unit by acceptance of a deed therefor or other conveyance thereof, whether or not it shall be so expressed in such deed or other conveyance, shall be deemed to covenant and agree, to pay to the Hotel Unit Owner annual charges for the operation and insurance of, and for payment of one hundred percent (100%) of the Hotel Shared Costs (the "Residential Units Allocated Share"), the establishment of reasonable reserves for the replacement of the Shared Components and the furnishings and finishings thereof, capital improvement charges, special charges and all other charges hereinafter referred to or lawfully imposed by the Hotel Unit Owner in connection with the repair, replacement, improvement, maintenance, management, operation, and insurance of the Shared Components, all such charges to be fixed, established and collected from time to time as herein provided. The annual charge, capital improvement charge and special charge, together with such interest thereon and costs of collection thereof as hereinafter provided, shall be a charge on the Residential Units and shall be a continuing lien upon the Residential Unit against which each such charge is made and upon all improvements thereon, from time to time existing. Each such charge, together with such interest thereon and costs of collection thereof as hereinafter provided, shall also be the personal obligation of the person who is the Owner of such Residential Unit at the time when the charge fell due and all subsequent Owners of that Unit until paid, except as provided in Section 12.5 below. Reference herein to charges shall be understood to include reference to any and all of said charges whether or not specifically mentioned. Each Unit shall be charged a share of the Hotel Shared Costs as is set forth on Exhibit "7" attached hereto. In addition to the regular and capital improvement charges which are or may be levied hereunder, the Hotel Unit Owner shall have the right to collect reasonable reserves for the replacement of the Shared Components and the furnishings and finishings thereof and to levy special charges against an Owner(s) to the exclusion of other Owners for the repair or replacement of damage to any portion of the Hotel Unit (including, without limitation, improvements, furnishings and finishings therein) caused by the misuse, negligence or other action or inaction of an Owner or his guests, tenants or invitees. Any such special charge shall be subject to all of the applicable provisions of this Section including, without

limitation, lien filing and foreclosure procedures and late charges and interest. Any special charge levied hereunder shall be due within the time specified by the Hotel Unit Owner in the action imposing such charge. The annual regular charges provided for in this Section shall commence on the first day of the month next following the recordation of this Declaration and shall be applicable through December 31 of such year. Each subsequent annual charge shall be imposed for the year beginning January 1 and ending December 31. The annual charges shall be payable in advance in monthly installments, or in annual, semi- or quarter-annual installments if so determined by the Hotel Unit Owner (absent which determination they shall be payable monthly). The charge amount (and applicable installments) may be changed at any time by the Hotel Unit Owner from that originally stipulated or from any other charge that is in the future adopted by the Hotel Unit Owner. The original charge for any year shall be levied for the calendar year (to be reconsidered and amended, if necessary, at any appropriate time during the year), but the amount of any revised charge to be levied during any period shorter than a full calendar year shall be in proportion to the number of months (or other appropriate installments) remaining in such calendar year. The Hotel Unit Owner shall fix the date of commencement and the amount of the charge against the Residential Units for each charge period, to the extent practicable, at least thirty (30) days in advance of such date or period, and shall, at that time, prepare a roster of the Residential Units and charges applicable thereto which shall be kept in the office of the Hotel Unit Owner and shall be open to inspection by any Owner. Written notice of the charge shall thereupon be sent to every Residential Unit Owner subject thereto twenty (20) days prior to payment of the first installment thereof, except as to special charges. In the event no such notice of the charges for a new charge period is given, the amount payable shall continue to be the same as the amount payable for the previous period, until changed in the manner provided for herein.

- 12.4 Effect of Non-Payment of Charge; the Personal Obligation; the Lien; Remedies of the Hotel Unit Owner. If the charges (or installments) provided for herein are not paid on the date(s) when due (being the date(s) specified herein or pursuant hereto), then such charges (or installments) shall become delinquent and shall, together with late charges, interest and the cost of collection thereof as hereinafter provided, thereupon become a continuing lien on the Residential Unit and all improvements thereon which shall bind such Residential Unit in the hands of the then Owner, and such Owner's heirs, personal representatives, successors and assigns. Except as provided in Section 12.5 to the contrary, the personal obligation of an Owner to pay such charge shall pass to his successors in title and recourse may be had against either or both. If any installment of a charge is not paid within ten (10) days from the date when it is due, same shall, at the option of the Hotel Unit Owner, be subject to a late charge not greater than the amount of such unpaid installment may be imposed (provided that only one late charge may be imposed on any one unpaid installment and if such installment is not paid thereafter, it and the late charge shall accrue interest at fifteen percent (15%) per annum from the date due until paid, but shall not be subject to additional late charges; provided further, however, that each other installment thereafter coming due shall be subject to one late charge each as aforesaid) and the Hotel Unit Owner may bring an action at law against the Owner(s) personally obligated to pay the same, may record a claim of lien (as evidence of its lien rights as hereinabove provided for) against the Residential Unit on which the charges and late charges are unpaid and all improvements thereon, may foreclose the lien against the applicable Residential Unit and all improvements thereon on which the charges and late charges are unpaid, or may pursue one or more of such remedies at the same time or successively, and attorneys' fees and costs actually incurred in preparing and filing the claim of lien and the complaint, if any, and prosecuting same, in such action shall be added to the amount of such charges, late charges and interest secured by the lien, and in the event a judgment is obtained, such judgment shall include all such sums as above provided and attorneys' fees actually incurred together with the costs of the action, through all applicable appellate levels. Failure of the Hotel Unit Owner (or any collecting entity) to send or deliver bills or notices of charges shall not relieve Owners from their obligations

without the prior written consent of 4/5th of the Residential Unit Owners and the Hotel Unit Owner. In the event of any conflict between the provisions of this Section 12, and the provisions of any other Section of this Declaration, the provisions of this Section 12 shall prevail and govern.

13. Insurance. Insurance obtained by the Hotel Unit Owner pursuant to the requirements of this Section 13 shall be governed by the following provisions:

13.1 Purchase, Custody and Payment.

- (a) Purchase. All insurance policies required to be obtained by the Hotel Unit Owner hereunder shall be issued by an insurance company authorized to do business in Florida or by surplus lines carriers offering policies for properties in Florida.
- (b) Named Insured. The named insured shall be the Hotel Unit Owner, individually, or such designee as may be designated by the Hotel Unit Owner, and as agent for the Association and the Owners of Units covered by the policy, without naming them, and as agent for the holders of any mortgage on a Unit (or any leasehold interest therein), without naming them. The Association, Unit Owners and the holders of any mortgage on a Unit (or any leasehold interest therein) shall be deemed additional insureds.
- (c) Custody of Policies and Payment of Proceeds. All policies shall provide that payments for losses made by the insurer shall be paid to the Hotel Unit Owner and the holders of any mortgage on the Hotel Unit, as their interests may appear.
- (d) Copies to Mortgagees. One copy of each insurance policy, or a certificate evidencing such policy, and all endorsements thereto, shall be furnished by the Hotel Unit Owner upon request to the holders of any mortgage on a Unit. Copies or certificates shall be furnished not less than ten (10) days prior to the beginning of the term of the policy, or not less than ten (10) days prior to the expiration of each preceding policy that is being renewed or replaced, as appropriate.
- (e) Personal Property and Liability. Except as specifically provided herein, the Hotel Unit Owner shall not be responsible to Residential Unit Owners to obtain insurance coverage upon the property lying within the boundaries of their Residential Unit, including, but not limited to, the Improvements, Owner's personal property, nor insurance for the Owners' personal liability and living expenses, nor for any other risks not otherwise insured in accordance herewith.

13.2 Coverage. The Hotel Unit Owner shall maintain insurance covering the following:

- (a) Casualty. The Shared Components, together with all fixtures, building service equipment, personal property and supplies constituting the Shared Components (collectively the "Insured Property"), shall be insured in such commercially reasonable amounts as may be determined from time to time by the Hotel Unit Owner. Notwithstanding the foregoing, the Insured Property shall not include, and shall specifically exclude, the Residential Units, the portions of the Hotel Unit which are not part of the Shared Components, and all furniture, furnishings, Unit floor coverings, wall coverings and ceiling coverings, other personal property owned, supplied or installed by Residential Unit Owners or tenants of Residential Unit Owners, and all electrical fixtures, appliances, air conditioner and/or heating equipment, water heaters, water filters, built-in cabinets and countertops, and window treatments, including curtains, drapes, blinds, hardware and similar window treatment components, or replacements or any of the foregoing which are located within the boundaries of a Unit and serve only one Unit and all air

conditioning compressors that service only an individual Unit, if any and to the extent not part of the Shared Components. Such policies may contain reasonable deductible provisions as determined by the Hotel Unit Owner. Such coverage shall afford protection against loss or damage by fire and other hazards covered by a standard extended coverage endorsement, and such other risks as from time to time are customarily covered with respect to buildings and improvements similar to the Insured Property in construction, location and use, including, but not limited to, vandalism and malicious mischief.

- (b) Liability. Comprehensive general public liability and automobile liability insurance covering loss or damage resulting from accidents or occurrences on or about or in connection with the Insured Property or adjoining driveways and walkways, or any work, matters or things related to the Insured Property, with such coverage as shall be required by the Hotel Unit Owner, and with a cross liability endorsement to cover liabilities of the Unit Owners as a group to any Unit Owner, and vice versa.
- (c) Worker's Compensation and other mandatory insurance, when applicable, to the extent applicable to the maintenance, operation, repair or replacement of the Shared Components.
- (d) Flood Insurance covering the Insured Property, if so determined by the Hotel Unit Owner.
- (e) Such Other Insurance as the Hotel Unit Owner shall determine from time to time to be desirable in connection with the Shared Components.

When appropriate and obtainable, each of the foregoing policies shall waive the insurer's right to: (i) as to property insurance policies, subrogation against the Association and against the Unit Owners individually and as a group, (ii) to pay only a fraction of any loss in the event of coinsurance or if other insurance carriers have issued coverage upon the same risk, and (iii) avoid liability for a loss that is caused by an act of the Hotel Unit Owner (or any of its employees, contractors and/or agents), one or more Unit Owners or as a result of contractual undertakings. Additionally, and each policy shall provide that the insurance provided shall not be prejudiced by any act or omissions of individual Unit Owners that are not under the control of the Hotel Unit Owner.

- 13.3 Additional Provisions. All policies of insurance shall provide that such policies may not be canceled or substantially modified without at least thirty (30) days' prior written notice to all of the named insureds, including all mortgagees. Prior to obtaining any policy of casualty insurance or any renewal thereof, the Hotel Unit Owner may obtain an appraisal from a fire insurance company, or other competent appraiser, of the full insurable replacement value of the Insured Property (exclusive of foundations), without deduction for depreciation, for the purpose of determining the amount of insurance to be effected pursuant to this Section.
- 13.4 Premiums. Premiums upon insurance policies purchased by the Hotel Unit Owner pursuant to this Section 13 shall be among the costs assessed against the Unit Owners in accordance with the provisions of Section 12. Premiums may be financed in such manner as the Hotel Unit Owner deems appropriate.
- 13.5 Share of Proceeds. All insurance policies obtained by or on behalf of the Hotel Unit Owner pursuant to this Section 13 shall be for the benefit of the Hotel Unit Owner, the Association, the Unit Owners and the holders of any mortgage on a Unit (or any leasehold interest therein), as their respective interests may appear. The duty of the Hotel Unit Owner shall be to receive such proceeds as are paid and to hold the same in trust for the purposes elsewhere stated herein, and for the benefit of the Unit Owners and the holders

of any mortgage on the subject Unit(s) (or any leasehold interest therein) in accordance with the Allocated Interest attributable thereto.

- 13.6 Distribution of Proceeds. Proceeds of insurance policies required to be maintained by the Hotel Unit Owner pursuant to this Section 13 shall be distributed to or for the benefit of the beneficial owners thereof in the following manner:
- (a) Reconstruction or Repair. If the damaged property for which the proceeds are paid is to be repaired or reconstructed, the proceeds shall be paid to defray the cost thereof as elsewhere provided herein. Any proceeds remaining after defraying such costs shall be distributed to the Owners, remittances to Unit Owners and their mortgagees being payable jointly to them.
- 13.7 Hotel Unit Owner as Agent. The Hotel Unit Owner is hereby irrevocably appointed as agent and attorney-in-fact for the Association and each Unit Owner and for each owner of a mortgage or other lien upon a Unit and for each owner of any other interest in the Condominium Property to adjust all claims arising under insurance policies purchased by the Hotel Unit Owner and to execute and deliver releases upon the payment of claims.
- 13.8 Unit Owners' Personal Coverage. The insurance required to be purchased by the Hotel Unit Owner pursuant to this Section 13 shall not cover claims against an Owner due to accidents occurring within his Unit, nor casualty or theft loss to the contents of an Owner's Unit. It shall be the obligation of the individual Unit Owner, if such Owner so desires, to purchase and pay for insurance as to all such and other risks not covered by insurance required to be carried by the Hotel Unit Owner hereunder.
- 13.9 Effect on Association. The Association shall only maintain such insurance as is expressly required to be maintained by the Association pursuant to the Act, it being the express intent of the Developer, as the Owner of each and every of the Units upon the recordation hereof, for itself and its successors and assigns, that the Association not be required to maintain insurance hereunder. To the extent that the Association is required to maintain insurance pursuant to the express requirements of the Act, then (a) as to any insurance required to be maintained by the Association, the Hotel Unit Owner shall be relieved and released of its obligation hereunder to maintain same, and (b) all of the provisions hereof regarding said insurance, any claims thereunder and the distribution and application of proceeds thereunder shall be governed in accordance with the terms of this Declaration governing the insurance required to be maintained by the Hotel Unit Owner as if the references herein to the Hotel Unit Owner were references to the Association.
- 13.10 Benefit of Mortgagees. Certain provisions in this Section 13 are for the benefit of mortgagees of Units and may be enforced by such mortgagees.
14. Reconstruction or Repair After Fire or Other Casualty.
- 14.1 Determination to Reconstruct or Repair. Subject to the immediately following paragraph, in the event of damage to or destruction of the Insured Property as a result of fire or other casualty, the Hotel Unit Owner shall determine whether or not to repair and/or restore the Insured Property, and if a determination is made to effect restoration, the Hotel Unit Owner shall disburse the proceeds of all insurance policies required to be maintained by it under Section 13 to the contractors engaged in such repair and restoration in appropriate progress payments.

In the event the Hotel Unit Owner determines not to effect restoration to the Shared Components, the net proceeds of insurance resulting from such damage or destruction shall be divided among all the Unit Owners in proportion to their Allocated Interests; provided, however, that no payment shall be made to a Unit Owner until there has first

been paid off out of his share of such fund all mortgages and liens on his Unit in the order of priority of such mortgages and liens.

- 14.2 Plans and Specifications. Any reconstruction or repair must be made substantially in accordance with the plans and specifications for the original Improvements and then applicable building and other codes; or if not, then in accordance with the plans and specifications approved by the Hotel Unit Owner, provided, however, that if any reconstruction is undertaken, same shall be undertaken in such a manner to restore the Residential Units to substantially the same condition they were in prior to the occurrence of the casualty.
- 14.3 Assessments. If the proceeds of the insurance are not sufficient to defray the estimated costs of reconstruction and repair to be effected by the Hotel Unit Owner, or if at any time during reconstruction and repair, or upon completion of reconstruction and repair, the funds for the payment of the costs of reconstruction and repair are insufficient, Assessments shall be made against the Unit Owners by the Hotel Unit Owner (which shall be deemed to be assessments made in accordance with, and secured by the lien rights contained in, Section 12 above) in sufficient amounts to provide funds for the payment of such costs. Such Assessments on account of damage to the Insured Property shall be in proportion to all of the Owners' respective Allocated Interests.
- 14.4 Benefit of Mortgagees. Certain provisions in this Section 14 are for the benefit of mortgagees of Units and may be enforced by any of them.
15. Condemnation.
- 15.1 Deposit of Awards. The taking of portions of the Shared Components by the exercise of the power of eminent domain shall be deemed to be a casualty, and the awards for that taking shall be deemed to be proceeds from insurance on account of the casualty and shall be deposited with the Hotel Unit Owner. Even though the awards may be payable to Unit Owners, the Unit Owners shall deposit the awards with the Hotel Unit Owner; and in the event of failure to do so, in the discretion of the Hotel Unit Owner, a charge shall be made against a defaulting Unit Owner in the amount of his award, or the amount of that award shall be set off against the sums hereafter made payable to that Owner.
- 15.2 Determination Whether to Continue Condominium. Whether the Condominium will be continued after condemnation will be determined in the manner provided for determining whether damaged property will be reconstructed and repaired after casualty. For this purpose, the taking by eminent domain also shall be deemed to be a casualty.
- 15.3 Disbursement of Funds. If the Condominium is terminated after condemnation, the proceeds of the awards and special Assessments will be deemed to be insurance proceeds and shall be owned and distributed in the manner provided with respect to the ownership and distribution of insurance proceeds if the Condominium is terminated after a casualty.
- 15.4 Taking of Shared Components. Awards for the taking of Shared Components shall be used to render the remaining portion of the Shared Components usable in the manner approved by the Hotel Unit Owner; provided, that if the cost of such work shall exceed the balance of the funds from the awards for the taking, the work shall be approved in the manner elsewhere required for capital improvements to the Shared Components. The balance of the awards for the taking of Shared Components, if any, shall be distributed to the Unit Owners in accordance with their Allocated Interests. Notwithstanding the foregoing, in the event that the costs of restoration resulting from any taking exceed \$1,000,000.00, then the Hotel Unit Owner shall have the sole right to determine whether or not to repair and/or restore in the same manner as is provided in Section 14 above with

respect to a casualty loss. If there is a mortgage on a Unit, the distribution shall be paid jointly to the Owner and the said mortgagees.

16. Occupancy and Use Restrictions. In order to provide for congenial occupancy of the Condominium and Association Property and for the protection of the values of the Units, the use of the Condominium Property shall be restricted to and shall be in accordance with the following provisions:

- 16.1 Occupancy. Each Residential Unit shall be used only in accordance with all applicable City, County and State codes, ordinances and regulations and the approvals and permits issued for the Improvements, and for no other purpose. In that regard, each Owner, by acceptance of a deed or otherwise acquiring title to a Unit, understands and agrees that the City of Miami Beach's zoning designation for the Condominium Property is "RM-3". Pursuant to that zoning designation, the Residential Units are intended for rental to transients on a day-to-day, week-to-week, or month-to-month basis, and are not intended for use or to be used as a permanent dwelling. As a result of such zoning designation, no Unit Owner nor any member of the Unit Owner's family, nor any person legally dependent upon the Unit Owner may establish a permanent residence at the Unit or any real property contiguous thereto. As such, under no circumstances shall (nor may) the Unit constitute his or her homestead, and accordingly, no Unit Owner shall be entitled to file a claim for homestead exemption from ad valorem taxes with respect to such Unit. Each Owner, by acceptance of title to a Unit, shall be deemed to have understood and agreed that, pursuant to applicable zoning regulations, certain restrictions have been imposed on continuous occupancy of the Units and to assure the transient nature of the use of the Units. Accordingly, each Unit shall be bound by all such restrictions. Each Owner understands and agrees that it shall be bound by the limitations of the zoning designation and hereby releases the Developer, and Hotel Unit Owner (and its and their members, and its and their partners, shareholders and employees) from any and all liabilities and/or damages resulting from same. Each Owner recognizes and agrees that the Hotel Unit may be used for any lawful purpose, and may be used by the Owner(s) thereof and its/their guests, tenants and invitees. The provisions of this subsection 16.1 shall not be applicable to Units used by the Developer for model apartments, sales or resales offices or management or administrative services.

The rights of Residential Unit Owners to use the Shared Components shall be limited to the extent granted in, and subject to the restrictions of, Section 3.4(d), and the obligation for payment of the assessments and charges as set forth in Section 12 (provided, however, that in no event shall an Owner be denied access to and from the Owner's Unit). It is contemplated (but without creating an obligation whatsoever) that in addition to use as a typical hallway for pedestrian passage, the Hotel Unit may be utilized by the Hotel Unit Owner in such a manner as to provide, or cause to be provided, certain hotel-related services to Residential Unit Owners, all of which shall be subject to rules, regulations and/or conditions as may be established by the Hotel Unit Owner from time to time in its sole and absolute discretion, including, without limitation, the right to require any person requesting such services to sign such agreements and pay such fees as may be required from time to time by the Hotel Unit Owner. Each Unit Owner, by acceptance of a deed or other conveyance of a Unit, recognizes and agrees that the Hotel Unit Owner is not required to provide any hotel related services, but if it determines to do so, in its sole discretion, it may condition the provisions of such services in any manner it so desires.

The provisions of this subsection 16.1 shall not be amended without the affirmative vote of not less than four-fifths (4/5ths) of the total voting interests of all Unit Owners.

- 16.2 Pet Restrictions. Not more than two (2) domesticated pets (either dogs, cats, or a dog and cat, provided that there are not more than two (2) such pets in total) may be maintained in

a Residential Unit provided such pets (a) do not, at maturity, weigh in excess of eighty (80) pounds each, (b) are permitted to be so kept by applicable laws and regulations, (c) are not kept, bred or maintained for any commercial purpose, (d) do not become a nuisance or annoyance to neighbors, and (e) are not a breed considered to be dangerous or a nuisance by the Hotel Unit Owner (in its sole and absolute discretion); provided that neither the Hotel Unit Owner, the Board, the Developer nor the Association shall be liable for any personal injury, death or property damage resulting from a violation of the foregoing and any occupant of a Unit committing such a violation shall fully indemnify and hold harmless the Hotel Unit Owner, the Board, the Developer, each Unit Owner and the Association in such regard. No reptiles or wildlife shall be kept in or on the Condominium Property (including Units). Unit Owners must pick up all solid wastes of their pets and dispose of such wastes appropriately. All pets (including cats) must be kept on a leash of a length that affords reasonable control over the pet at all times when outside the Unit. No pets may be kept on patio areas or on balconies of any Units when the Owner is not in the Unit. Pets may not be taken in any elevators in the Condominium other than in the service elevator(s). Violation of the provisions of this Section 16.2 shall entitle the Hotel Unit Owner to all of its rights and remedies, including, but not limited to, the right to fine Unit Owners (as provided in any applicable rules and regulations) and/or to require any pet to be permanently removed from the Condominium Property. This Section 16.2 shall not prohibit the keeping of fish or a caged household-type bird(s) in a Residential Unit, provided that a bird(s) is not kept on Limited Common Elements or becomes a nuisance or annoyance to neighbors.

16.3 Third Party Service Providers. The Hotel Unit Owner shall have the right, in its sole and absolute discretion, to establish reasonable regulations from time to time with respect to the provision of hotel services by third party providers, including, but not limited to, solicitation and/or provision of housekeeping services, pool services, valet services, engineering services, personal services (i.e., massage, personal training, dry cleaning, etc.) and/or food and beverage service, to the Condominium, the Unit Owners and their guests, tenants and invitees. No amendment to this Declaration or rule of the Association shall be adopted to impair or abridge the rights herein granted without an affirmative vote of not less than 80% of the voting interests of the Unit Owners.

16.4 Alterations. Without limiting the generality of Section 8.1 hereof, but subject to Section 9 hereof, no Residential Unit Owner shall cause or allow improvements or changes to any Residential Unit, Shared Components, Common Elements or Association Property, including, but not limited to, painting or other decorating of any nature, installing any electrical wiring, television antenna, machinery, or air-conditioning units, which in any manner change the appearance of any portion of the Building or the exterior of said Unit, without obtaining the prior written consent of the Association (as to the Common Elements only) or the Hotel Unit Owner (as to all other portions of the Condominium Property, in the manner specified in section 8.1 hereof. Further, any Unit which is built out for handicap accessibility and/or compliance with applicable disability requirement of City, State or Federal law, must be maintained in that condition and can not be altered. Additionally, curtains or drapes (or linings thereof) which face the exterior windows or glass doors of Units shall be consistent with the standard adopted from time to time by the Hotel Unit Owner. Notwithstanding the provisions of Section 8.1 above, any Unit Owner may display one portable, removable United States flag in a respectful way, and, on Armed Forces Day, Memorial Day, Flag Day, Independence Day and Veterans Day, may display in a respectful way portable, removable official flags, not larger than 4 1/2 feet by 6 feet, that represent the United States Army, Navy, Air Force, Marine Corps or Coast Guard.

The Hotel Unit Owner shall have the right to establish non-discriminatory restrictions on any and all persons performing work within the Condominium Property, including, without limitation, by (a) restricting the hours during which work may be performed and restricting access of contractors to certain areas, (b) requiring that all persons performing any work

have all necessary licenses and permits to perform the work, (c) requiring that all persons performing any work have adequate insurance coverage and that the Association be a named additional insured on such policy(ies), and (d) requiring a security deposit or other collateral to protect against damage that may be caused during such work.

- 16.5 Nuisances. No nuisances (as defined by the Hotel Unit Owner) shall be allowed on the Condominium or Association Property, nor shall any use or practice be allowed which is a source of annoyance to occupants of Units or which interferes with the peaceful possession or proper use of the Condominium and/or Association Property by its residents, occupants or members. No activity specifically permitted by this Declaration, including, without limitation, activities or businesses conducted from the Hotel Unit, shall be deemed a nuisance.

Each Unit Owner, by acceptance of a deed or other conveyance of a Unit shall be deemed to understand and agree that inasmuch as hotel operations are intended to be conducted from the Condominium Property, noise and/or other disruptions may occur. By acquiring a Unit, each Unit Owner, for such Unit Owner and its guests, tenants and invitees, and its and their successors and/or assigns, agrees not to object to the operations of the hotel, which may include, noise, disruption and the playing of music outdoors, and hereby agrees to release Developer and the Hotel Unit Owner from any and all claims for damages, liabilities and/or losses suffered as a result of the existence of the hotel and the operations from same, and the noises and disruptions resulting therefrom.

- 16.6 No Improper Uses. No improper, offensive, hazardous or unlawful use shall be made of the Condominium or Association Property or any part thereof, and all valid laws, zoning ordinances and regulations of all governmental bodies having jurisdiction thereover shall be observed. Violations of laws, orders, rules, regulations or requirements of any governmental agency having jurisdiction thereover, relating to any portion of the Condominium and/or Association Property, shall be corrected by, and at the sole expense of, the party obligated to maintain or repair such portion of the Condominium Property, as elsewhere herein set forth. Notwithstanding the foregoing and any provisions of this Declaration, the Articles of Incorporation or By-Laws, the Association shall not be liable to any person(s) for its failure to enforce the provisions of this Section 16.6. No activity specifically permitted by this Declaration shall be deemed to be a violation of this Section.

- 16.7 Leases. It is intended that the Residential Units may be used for transient and/or hotel rentals. As such, leasing of Units or portions thereof shall not be subject to the approval of the Association and/or any other limitations, other than as expressly provided herein. However, all leasing of Units or portions thereof shall be made in accordance with all applicable zoning ordinances and other limitations imposed by the City of Miami Beach.

The lease of a Residential Unit for a term of six (6) months or less is subject to a tourist development tax assessed pursuant to Section 125.0104, Florida Statutes. A Residential Unit Owner leasing his or her Unit for a term of six (6) months or less agrees, and shall be deemed to have agreed, for such Owner, and his or her heirs, personal representatives, successors and assigns, as appropriate, to hold the Association, the Developer and all other Unit Owners harmless from and to indemnify them for any and all costs, claims, damages, expenses or liabilities whatsoever, arising out of the failure of such Unit Owner to pay the tourist development tax and/or any other tax or surcharge imposed by the State of Florida, the County or the City with respect to rental payments or other charges under the lease, and such Unit Owner shall be solely responsible for and shall pay to the applicable taxing authority, prior to delinquency, the tourist development tax and/or any other tax or surcharge due with respect to rental payments or other charges under the lease.

Every lease of a Unit shall specifically provide (or, if it does not, shall be automatically deemed to provide) that a material condition of the lease shall be the tenant's full compliance with the covenants, terms, conditions and restrictions of this Declaration (and all Exhibits hereto) and with any and all rules and regulations adopted by the Hotel Unit Owner from time to time, including, without limitation, any and all regulations and/or procedures established by applicable law and/or adopted by the Hotel Unit Owner regarding mandatory check-in for Owners and residents, coordination of charging privileges and other matters reasonably necessary to allow Owners and hotel guests to be well integrated into a unified structure and operation. The Unit Owner will be jointly and severally liable with the tenant to the Association and/or Hotel Unit Owner, as applicable, for any amount which is required by the Association and/or the Hotel Unit Owner to repair any damage to the Common Elements, the Hotel Unit and/or the Shared Components resulting from acts or omissions of tenants (as determined in the sole discretion of the Association as to Common Elements or the Hotel Unit Owner as to the Hotel Unit or Shared Components) and to pay any claim for injury or damage to property caused by the negligence of the tenant and special charges may be levied against the Unit therefor. All tenancies are hereby made subordinate to any lien filed by the Condominium Association or the Hotel Unit Owner, whether prior or subsequent to such lease. Notwithstanding the foregoing, there shall be no minimum lease term for the rental of Residential Units, nor shall there be a maximum number of times that a Residential Unit may be leased. There shall be no amendment to this Section 16.7, or to any other provision of this Declaration which shall impair the rights established in this Section 16.7, without the prior approval of eighty percent (80%) of the entire voting interests of the Residential Unit Owners and the entire voting interests of the Hotel Unit Owner.

16.8 Weight and Sound Restrictions. Hard and/or heavy surface floor coverings, including, without limitation, tile or wood, may not be installed in any part of a Unit other than the kitchen and bathroom(s), without the consent of the Hotel Unit Owner. The Hotel Unit Owner shall not approve the installation of any hard and/or heavy surface floor coverings (for which approval is required) unless the aggregate sound isolation and acoustical treatment carries a minimum Sound Transmission Classification (STC) of 48 and a minimum Impact Isolation Classification (IIC) of 46. The installation of the foregoing insulation materials shall be performed in a manner that provides proper mechanical isolation of the flooring materials from any rigid part of the building structure, whether of the concrete subfloor (vertical transmission) or adjacent walls and fittings (horizontal transmission) and must be installed prior to the Unit being occupied. Notwithstanding the foregoing and the provisions of Section 8.1 above, the floor coverings (and insulation and adhesive material therefor) installed on any balcony or patio shall not exceed a thickness of seven eighths of one inch (7/8"). Also, the installation of any improvement or heavy object must be submitted to and approved by the Hotel Unit Owner, and be compatible with the overall structural design of the building. The Hotel Unit Owner may require a structural engineer to review certain of the proposed improvements, with such review to be at the Owner's sole expense. Owners will be held strictly liable for violations of these restrictions and for all damages resulting therefrom and the Hotel Unit Owner has the right to require immediate removal of violations. Each Owner, by acceptance of a deed or other conveyance of their Unit, hereby acknowledges and agrees that sound transmission in a high-rise building such as the Condominium is very difficult to control, and that noises from adjoining or nearby Units and/or mechanical equipment can often be heard in another Unit. The Developer does not make any representation or warranty as to the level of sound transmission between and among Units and the other portions of the Condominium Property, and/or from elevators or mechanical equipment, and each Unit Owner hereby waives and expressly releases any such warranty and claim for loss or damages resulting from sound transmission.

16.9 Exterior Improvements. Without limiting the generality of Sections 8.1 or 16.4 hereof, but subject to any provision of this Declaration specifically permitting same, no Unit Owner

shall cause anything to be affixed or attached to, hung, displayed or placed on the exterior walls, doors, balconies or windows of the Building (including, but not limited to, awnings, signs, storm shutters, screens, window tinting, furniture, fixtures and equipment), without the prior written consent of the Hotel Unit Owner.

- 16.10 Access to Units. In order to facilitate access to Units by the Association for the purposes enumerated in Section 9.1 hereof, it shall be the responsibility of all Unit Owners to deliver a set of keys (or access card or code, as may be applicable) to their respective Units to the Association and the Hotel Unit Owner to use in the performance of its functions. No Owner shall change the locks to his or her Unit. The Hotel Unit Owner shall have the right to adopt reasonable regulations from time to time regarding access control and check-in, check-out procedures which shall be applicable to both hotel guests and Unit Owners.
- 16.11 Mitigation of Dampness and Humidity. No Unit Owner shall install, within his or her Unit, or upon the Common Elements or Association Property, non-breathable wall-coverings, low-permeance paints or mirrored wall coverings. Additionally, any and all built-in casework, furniture, and or shelving in a Unit must be installed over floor coverings to allow air space and air movement and shall not be installed with backboards flush against any gypsum board wall. Additionally, all Unit Owners, whether or not occupying the Unit, shall periodically run the air conditioning system to maintain the Unit temperature, whether or not occupied, at no higher than 78°F, to minimize humidity in the Unit. Leaks, leaving exterior doors or windows open, wet flooring and moisture will contribute to the growth of mold, mildew, fungus or spores. Each Unit Owner, by acceptance of a deed, or otherwise acquiring title to a Unit, shall be deemed to have agreed that neither Developer, nor the Hotel Unit Owner is responsible, and each hereby disclaims any responsibility for any illness, personal injury, death or allergic reactions which may be experienced by the Unit Owner, its family members and/or its or their guests, tenants and invitees and/or the pets of all of the aforementioned persons, as a result of mold, mildew, fungus or spores. It is the Unit Owner's responsibility to keep the Unit clean, dry, well-ventilated and free of contamination. While the foregoing are intended to minimize the potential development of molds, fungi, mildew and other mycotoxins, each Owner understands and agrees that there is no method for completely eliminating the development of molds or mycotoxins. The Developer does not make any representations or warranties regarding the existence or development of molds or mycotoxins and each Owner shall be deemed to waive and expressly release any such warranty and claim for loss or damages resulting from the existence and/or development of same. In furtherance of the foregoing, in the event that the Association and/or the Hotel Unit Owner reasonably believes that the provisions of this Section 16.11 are not being complied with, then, the Association and/or the Hotel Unit Owner shall have the right (but not the obligation) to enter the Unit (without requiring the consent of the Owner or any other party) to turn on the air conditioning in an effort to cause the temperature of the Unit to be maintained as required hereby.
- 16.12 Antennas, Satellite Dishes. To the extent permitted by applicable law, no Owner may install any antenna, satellite dish or other transmitting or receiving apparatus in or upon his or her Unit (and/or areas appurtenant thereto), without the prior written consent of the Hotel Unit Owner.
- 16.13 Parking. All vehicle parking shall be by valet only and subject to the procedures, rules and regulations adopted from time to time pursuant to the Reciprocal Easement Agreement.
- 16.14 Storage on Balconies/Terraces. No equipment, materials or other items shall be kept or stored on any balcony or terrace area of the Condominium, including but not limited to towels, clothing, bicycles. The foregoing shall not prevent, however, placing and using patio-type furniture, planters and other items in such areas if same are normally and customarily used for a residential balcony or terrace area, but all such patio furniture, planters and others must be reasonably acceptable to the Hotel Unit Owner. In the event

of any doubt or dispute as to whether a particular item is permitted hereunder, the decision of the Hotel Unit Owner shall be final and dispositive.

- 16.15 Open House. No person shall be permitted to have an "open house", a "broker's open" or host any other event intended to attract multiple prospects at a single time, in connection with any attempt to sell or lease a Unit.
- 16.16 Relief. The Hotel Unit Owner shall have the power (but not the obligation) to grant relief in particular circumstances from the provisions of specific restrictions contained in this Section 16 for good cause shown.
- 16.17 Effect on Developer. Subject to the following exceptions, the restrictions and limitations set forth in this Section 16 shall not apply to the Developer nor to Units owned by the Developer. The Developer shall not be exempt from the restrictions, if any, relating to requirements that leases or lessees be approved by the Association, pet restrictions, occupancy of Units based on age and vehicular restrictions, except as such vehicular restrictions relate to the Developer's construction, maintenance, sales, resales, leasing and other marketing and financing activities, which activities the Developer can perform.
17. Selling, Leasing and Mortgaging of Units. Subject to the provisions of this Declaration, each Unit Owner shall have the right to sell, lease or mortgage his Unit without restriction. When a Unit is leased, a tenant shall have all use rights in Association Property and those Common Elements otherwise readily available for use generally by Unit Owners, and the Owner of the leased Unit shall not have such rights, except as a guest. Nothing herein shall interfere with the access rights of the Unit Owner as a landlord pursuant to Chapter 83, Florida Statutes. The Association shall have the right to adopt rules to prohibit dual usage by a Unit Owner and a tenant of Association Property and Common Elements otherwise readily available for use generally by Owners.
18. Compliance and Default. The Association, each Unit Owner, occupant of a Unit, tenant and other invitee of a Unit Owner shall be governed by and shall comply with the terms of this Declaration and all exhibits annexed hereto and the rules and regulations adopted pursuant to those documents, as the same may be amended from time to time and the provisions of all of such documents shall be deemed incorporated into any lease of a Unit whether or not expressly stated in such lease. The Association (and Unit Owners, if appropriate) shall be entitled to the following relief in addition to the remedies provided by the Act:
- 18.1 Mandatory Nonbinding Arbitration of Disputes. Prior to the institution of court litigation, the parties to a Dispute shall petition the Division for nonbinding arbitration. The arbitration shall be conducted according to rules promulgated by the Division and before arbitrators employed by the Division. The filing of a petition for arbitration shall toll the applicable statute of limitation for the applicable Dispute, until the arbitration proceedings are completed. Any arbitration decision shall be presented to the parties in writing, and shall be deemed final if a complaint for trial de novo is not filed in a court of competent jurisdiction in which the Condominium is located within thirty (30) days following the issuance of the arbitration decision. The prevailing party in the arbitration proceeding shall be awarded the costs of the arbitration, and attorneys' fees and costs incurred in connection with the proceedings. The party who files a complaint for a trial de novo shall be assessed the other party's arbitration costs, courts costs and other reasonable costs, including, without limitation, attorneys' fees, investigation expenses and expenses for expert or other testimony or evidence incurred after the arbitration decision, if the judgment upon the trial de novo is not more favorable than the arbitration decision. If the judgment is more favorable, the party who filed a complaint for trial de novo shall be awarded reasonable court costs and attorneys' fees. Any party to an arbitration proceeding may enforce an arbitration award by filing a petition in a court of competent jurisdiction in which the Condominium is located. A petition may not be granted unless the time for appeal by

the filing of a complaint for a trial de novo has expired. If a complaint for a trial de novo has been filed, a petition may not be granted with respect to an arbitration award that has been stayed. If the petition is granted, the petitioner may recover reasonable attorneys' fees and costs incurred in enforcing the arbitration award.

18.2 Negligence and Compliance. A Unit Owner and/or tenant of a Unit shall be liable for the expense of any maintenance, repair or replacement made necessary by his or her negligence or by that of any member of his or her family or his or her guests, employees, agents or lessees, but only to the extent such expense is not met by the proceeds of insurance actually collected in respect of such negligence by the Association and/or Hotel Unit Owner, as applicable. In the event a Unit Owner, tenant or occupant fails to maintain a Unit or fails to cause such Unit to be maintained, or fails to observe and perform all of the provisions of the Declaration, the By-Laws, the Articles of Incorporation of the Association, applicable rules and regulations, or any other agreement, document or instrument affecting the Condominium Property or administered by the Association or Hotel Unit Owner, in the manner required, the Association or Hotel Unit Owner, as applicable, shall have the right to proceed in equity to require performance and/or compliance, to impose any applicable fines, to sue at law for damages, and to charge the Unit Owner for the sums necessary to do whatever work is required to put the Unit Owner or Unit in compliance, provided, however, that nothing contained in this Section 18.2 shall authorize the Association to enter a Unit to enforce compliance. In any proceeding arising because of an alleged failure of a Unit Owner, a tenant or the Association to comply with the requirements of the Act, this Declaration, the exhibits annexed hereto, or the rules and regulations adopted pursuant to said documents, as the same may be amended from time to time, the prevailing party shall be entitled to recover the costs of the proceeding and such reasonable attorneys' fees (including appellate attorneys' fees). A Unit Owner prevailing in an action with the Association, in addition to recovering his reasonable attorneys' fees, may recover additional amounts as determined by the court to be necessary to reimburse the Unit Owner for his or her share of Assessments levied by the Association to fund its expenses of the litigation.

19. Termination of Condominium. The Condominium shall continue until (i) terminated by casualty loss, condemnation or eminent domain, as more particularly provided in this Declaration, or (ii) such time as withdrawal of the Condominium Property from the provisions of the Act is authorized by a vote of Owners owning at least eighty percent (80%) of the applicable interests in the Common Elements and by the Primary Institutional First Mortgagee. In the event such withdrawal is authorized as aforesaid, the Condominium Property shall be subject to an action for partition by any Unit Owner, mortgagee or lienor as if owned in common in which event the net proceeds of the partition sale shall be divided among all Unit Owners in proportion to their respective interests in the Common Elements, provided, however, that no payment shall be made to a Unit Owner until there has first been paid off out of his share of such net proceeds all mortgages and liens on his Unit in the order of their priority. The termination of the Condominium, as aforesaid, shall be evidenced by a certificate of the Association executed by its President and Secretary, certifying as to the basis of the termination and said certificate shall be recorded among the public records of the County. The Association shall, within thirty (30) business days following such recordation, provide the Division with a copy of such recorded certificate. This Section may not be amended without the consent of the Developer as long as it owns any Unit.

20. Additional Rights of Mortgagees and Others.

20.1 Availability of Association Documents. The Association shall have current and updated copies of the following available for inspection by Institutional First Mortgagees during normal business hours or under other reasonable circumstances as determined by the Board: (a) this Declaration; (b) the Articles; (c) the By-Laws; (d) the rules and regulations of the Association; and (e) the books, records and financial statements of the Association.

- 20.2 Notices. Any holder, insurer or guarantor of a mortgage on a Unit shall have, if first requested in writing, the right to timely written notice of:
- (a) any condemnation or casualty loss affecting a material portion of the Condominium and/or Association Property or the affected mortgaged Unit;
 - (b) a sixty (60) day delinquency in the payment of the Assessments on a mortgaged Unit;
 - (c) the occurrence of a lapse, cancellation or material modification of any insurance policy or fidelity bond maintained by the Association;
 - (d) any proposed action which requires the consent of a specified number of mortgage holders.
- 20.3 Additional Rights. Institutional First Mortgagees shall have the right, upon written request to the Association, to: (a) receive a copy of an audited financial statement of the Association for the immediately preceding fiscal year if such statements were prepared; and (b) receive notices of and attend Association meetings.

21. Nature of Improvements.

- 21.1 Resort Condominium. The Condominium is classified as a "resort condominium" under Section 509.242, Florida Statutes because the owners of the Residential Units shall be permitted to lease their Units more than three (3) times in a calendar year for periods of less than thirty (30) days or one (1) calendar month, whichever is less.
- 21.2 City Zoning Designation. As set forth in Section 16.1 above, the City's zoning designation for the Condominium Property is "RM-3". Pursuant to that zoning designation, the Residential Units are intended for rental to transients on a day-to-day, week-to-week, or month-to-month basis, and are not intended for use or to be used as a permanent dwelling. As a result of such zoning designation, no Unit Owner nor any member of the Unit Owner's family, nor any person legally dependent upon the Unit Owner may establish a permanent residence at the Unit or any real property contiguous thereto. As such, under no circumstances shall (nor may) the Unit constitute his or her homestead, and accordingly, no Unit Owner shall be entitled to file a claim for homestead exemption from ad valorem taxes with respect to such Unit. Each Owner understands and agrees that it shall be bound by the limitations of the zoning designation and hereby releases the Developer, and Hotel Unit Owner (and its and their members, and its and their partners, shareholders and employees) from any and all liabilities and/or damages resulting from same.
- 21.3 Telephone Service. All telephone service within the Units is intended to operate through a central switchboard controlled by the Hotel Unit Owner (and which shall be deemed part of the Shared Components). Each Unit Owner, in addition to payment of the allocable share of the Shared Costs, shall also be obligated for payment of such usage charges as may be established from time to time by the Hotel Unit Owner in connection with usage of the switchboard, which may include, without limitation, long distance charges, long distance and local access surcharges and/or per call or per minute fees. The Hotel Unit Owner shall be entitled to all collection remedies to collect all such charges and surcharges as are available for the collection of the Unit's allocable share of the Shared Costs, including, without limitation, the right to impose a lien upon the Unit (and the right to foreclose that lien in the same manner as it may foreclose the lien for an Owner's failure to pay its share of the Shared Costs).

22. Covenant Running With the Realty. All provisions of this Declaration, the Articles, By-Laws and applicable rules and regulations of the Association, shall, to the extent applicable and unless otherwise expressly herein or therein provided to the contrary, be perpetual and be construed to be covenants running with the Realty and with every part thereof and interest therein, and all of the provisions hereof and thereof shall be binding upon and inure to the benefit of the Developer and subsequent owner(s) of the Realty or any part thereof, or interest therein, and their respective heirs, personal representatives, successors and assigns, but the same are not intended to create nor shall they be construed as creating any rights in or for the benefit of the general public. All present and future Unit Owners, tenants and occupants of Units shall be subject to and shall comply with the provisions of this Declaration, the Articles, By-Laws and applicable rules and regulations, all as they may be amended from time to time. The acceptance of a deed or conveyance, or the entering into of a lease, or the entering into occupancy of any Unit, shall constitute an adoption and ratification of the provisions of this Declaration, and the Articles, By-Laws and applicable rules and regulations of the Association, all as they may be amended from time to time, including, but not limited to, a ratification of any appointments of attorneys-in-fact contained herein.
23. Disclaimer of Warranties. Except only for those warranties provided in Section 718.203, Florida Statutes (and then only to the extent applicable and not yet expired), to the maximum extent lawful Developer hereby disclaims any and all and each and every express or implied warranties, whether established by statutory, common, case law or otherwise, as to the design, construction, sound and/or odor transmission, existence and/or development of molds, mildew, toxins or fungi, furnishing and equipping of the Condominium Property, including, without limitation, any implied warranties of habitability, fitness for a particular purpose or merchantability, compliance with plans, all warranties imposed by statute (other than those imposed by Section 718.203, Florida Statutes, and then only to the extent applicable and not yet expired) and all other express and implied warranties of any kind or character. Developer has not given and the Unit Owner has not relied on or bargained for any such warranties. Each Unit Owner, by accepting a deed to a Unit, or other conveyance thereof, shall be deemed to represent and warrant to Developer that in deciding to acquire the Unit, the Unit Owner relied solely on such Unit Owner's independent inspection of the Unit and the Condominium. The Unit Owner has not received nor relied on any warranties and/or representations from Developer of any kind, other than as expressly provided herein.

All Unit Owners, by virtue of their acceptance of title to their respective Units (whether from the Developer or another party) shall be deemed to have automatically waived all of the aforesaid disclaimed warranties and incidental and consequential damages. The foregoing shall also apply to any party claiming by, through or under a Unit Owner, including a tenant thereof.

Further, given the climate and humid conditions in South Florida, molds, mildew, toxins and fungi may exist and/or develop within the Unit and/or the Condominium Property. Each Owner is hereby advised that certain molds, mildew, toxins and/or fungi may be, or if allowed to remain for a sufficient period may become, toxic and potentially pose a health risk. By acquiring title to a Unit, each Owner shall be deemed to have assumed the risks associated with molds, mildew, toxins and/or fungi and to have released the Developer and Hotel Unit Owner from any and all liability resulting from same, including, without limitation, any liability for incidental or consequential damages (which may result from, without limitation, the inability to possess the Unit, inconvenience, moving costs, hotel costs, storage costs, loss of time, lost wages, lost opportunities and/or personal injury). Without limiting the generality of the foregoing, leaks, leaving exterior doors or windows open, wet flooring and moisture will contribute to the growth of mold, mildew, fungus or spores. Each Unit Owner, by acceptance of a deed, or otherwise acquiring title to a Unit, shall be deemed to have agreed that Developer is not responsible, and the Developer hereby disclaims any responsibility for any illness or allergic reactions, personal injury or death which may be experienced by the Unit Owner, its family members and/or its or their guests, tenants and

invitees and to any pets of persons aforementioned in this sentence, as a result of mold, mildew, fungus or spores. It is the Unit Owner's responsibility to keep the Unit clean, dry, well-ventilated and free of contamination.

Each Owner understands and agrees that for some time in the future, it, and its guests, tenants and invitees may be disturbed by the noise, commotion and other unpleasant effects of nearby construction activity and as a result Owner and its guests, tenants and invitees may be impeded in using portions of the Condominium Property by that activity. Because the Condominium is located in an urban area, demolition or construction of buildings and other structures within the immediate area or within the view lines of any particular Unit or of any part of the Condominium (the "Views") may block, obstruct, shadow or otherwise affect Views, which may currently be visible from the Unit or from the Condominium. Therefore, each Owner, for itself, its successors and assigns, agrees to release Developer and Hotel Unit Owner and its and their members, and its and their officers, members, directors and employees and every affiliate and person related or affiliated in any way with any of them (the "Affiliates") from and against any and all losses, claims, demands, damages, costs and expenses of whatever nature or kind, including attorney's fees and costs, including those incurred through all arbitration and appellate proceedings, related to or arising out of any claim against the Developer, Hotel Unit Owner or Affiliates related to Views or the disruption, noise, commotion, and other unpleasant effects of nearby development or construction. As a result of the foregoing, there is no guarantee of view, security, privacy, location, design, density or any other matter.

Each Owner, by acceptance of a deed or other conveyance of a Unit, understands and agrees that there are various methods for calculating the square footage of a Unit, and that depending on the method of calculation, the quoted square footage of the Unit may vary by more than a nominal amount. Additionally, as a result of in the field construction, normal construction variances, other permitted changes to the Unit, and settling and shifting of improvements, actual square footage of a Unit may also be affected. By accepting title to a Unit, the applicable Owner(s) shall be deemed to have conclusively agreed to accept the size and dimensions of the Unit, regardless of any variances in the square footage from that which may have been disclosed at any time prior to closing. Without limiting the generality of this Section 23, Developer does not make any representation or warranty as to the actual size, dimensions (including ceiling heights) or square footage of any Unit.

24. Coastal Construction Control Line. Each Unit Owner, by acceptance of a deed or other conveyance of their Unit, acknowledges and agrees that the Units, the Building and other portions of the Condominium Property may be located in coastal areas partially or totally seaward of the coastal construction control line as defined in Section 161.053, F.S. Each Unit Owner is fully apprised of the character of the regulation of property in such coastal areas and thereby expressly waives and releases any claim against the Developer as a result of the limitation on improvements or reconstruction resulting from the regulation of property in such coastal areas.

25. Additional Provisions.

25.1 Notices. All notices to the Association required or desired hereunder or under the By-Laws of the Association shall be sent by certified mail (return receipt requested) to the Association in care of its office at the Condominium, or to such other address as the Association may hereafter designate from time to time by notice in writing to all Unit Owners. All notices to the Hotel Unit Owner required or desired hereunder or under the By-Laws of the Association shall be sent by certified mail (return receipt requested) to the Hotel Unit Owner in care of its office at the Condominium, or to such other address as the Hotel Unit Owner may hereafter designate from time to time by notice in writing to all Unit Owners. Except as provided specifically in the Act, all notices to any Unit Owner shall be sent by first class mail to the Condominium address of such Unit Owner, or such other

address as may have been designated by him from time to time, in writing, to the Association. All notices to mortgagees of Units shall be sent by first class mail to their respective addresses, or such other address as may be designated by them from time to time, in writing to the Association. All notices shall be deemed to have been given when mailed in a postage prepaid sealed wrapper, except notices of a change of address, which shall be deemed to have been given when received, or 5 business days after proper mailing, whichever shall first occur.

- 25.2 Mortgagees. Anything herein to the contrary notwithstanding, neither the Association nor the Hotel Unit Owner shall be responsible to any mortgagee or lienor of any Unit hereunder, and each may assume the Unit is free of any such mortgages or liens, unless written notice of the existence of such mortgage or lien is received by the Association and Hotel Unit Owner, as applicable.
- 25.3 Exhibits. There is hereby incorporated in this Declaration all materials contained in the Exhibits annexed hereto, except that as to such Exhibits, any conflicting provisions set forth therein as to their amendment, modification, enforcement and other matters shall control over those hereof.
- 25.4 Signature of President and Secretary. Wherever the signature of the President of the Association is required hereunder, the signature of a vice-president may be substituted therefor, and wherever the signature of the Secretary of the Association is required hereunder, the signature of an assistant secretary may be substituted therefor, provided that the same person may not execute any single instrument on behalf of the Association in two separate capacities.
- 25.5 Governing Law. Should any dispute or litigation arise between any of the parties whose rights or duties are affected or determined by this Declaration, the Exhibits annexed hereto or applicable rules and regulations adopted pursuant to such documents, as the same may be amended from time to time, said dispute or litigation shall be governed by the laws of the State of Florida.
- 25.6 Severability. The invalidity in whole or in part of any covenant or restriction, or any section, subsection, sentence, paragraph, clause, phrase or word, or other provision of this Declaration, the Exhibits annexed hereto, or applicable rules and regulations adopted pursuant to such documents, as the same may be amended from time to time, shall not affect the validity of the remaining portions thereof which shall remain in full force and effect.
- 25.7 Waiver. The failure of the Association or any Unit Owner to enforce any covenant, restriction or other provision of the Act, this Declaration, the exhibits annexed hereto, or the rules and regulations adopted pursuant to said documents, as the same may be amended from time to time, shall not constitute a waiver of their right to do so thereafter.
- 25.8 Ratification. Each Unit Owner, by reason of having acquired ownership (whether by purchase, gift, operation of law or otherwise), and each occupant of a Unit, by reason of his occupancy, shall be deemed to have acknowledged and agreed that all of the provisions of this Declaration, and the Articles and By-Laws of the Association, and applicable rules and regulations, are fair and reasonable in all material respects.
- 25.9 Execution of Documents; Attorney-in-Fact. Without limiting the generality of other Sections of this Declaration and without such other Sections limiting the generality hereof, each Owner, by reason of the acceptance of a deed to such Owner's Unit, hereby agrees to execute, at the request of the Developer, all documents or consents which may be required by all governmental agencies to allow the Developer and its affiliates to complete the plan of development of the Condominium as such plan may be hereafter amended, and each such Owner further appoints hereby and thereby the Developer as such Owner's

agent and attorney-in-fact to execute, on behalf and in the name of such Owners, any and all of such documents or consents. This power of attorney is irrevocable and coupled with an interest. Further, the Hotel Unit Owner is hereby granted the power to execute all documents or consents, on behalf of all Residential Unit Owners (and their mortgagees), required by all governmental and/or quasi-governmental agencies in connection with land use and development matters affecting the Condominium Property (including, without limitation, plats, waivers of plat, unities of title, covenants in lieu thereof, etc.), and in that regard, each Owner of a Residential Unit, by acceptance of the deed to such Owner's Unit, and each mortgagee of a Unit, by acceptance of a lien on said Unit, appoints and designates the Hotel Unit Owner, as such Owner's agent and attorney-in-fact to execute any and all such documents or consents. The provisions of this Section may not be amended without the consent of the Developer.

- 25.10 Gender; Plurality. Wherever the context so permits, the singular shall include the plural, the plural shall include the singular, and the use of any gender shall be deemed to include all or no genders.
- 25.11 Captions. The captions herein and in the Exhibits annexed hereto are inserted only as a matter of convenience and for ease of reference and in no way define or limit the scope of the particular document or any provision thereof.
- 25.12 Liability of the Association. Notwithstanding anything contained herein or in the Articles of Incorporation, By-laws, any rules or regulations of the Association or any other document governing or binding the Association (collectively, the "Association Documents"), the Association, except to the extent specifically provided to the contrary herein, shall not be liable or responsible for, or in any manner a guarantor or insurer of, the health, safety or welfare of any Owner, occupant or user of any portion of the Condominium and/or Association Property including, without limitation, Owners and their guests, invitees, agents, servants, contractors or subcontractors or for any property of any such persons. Without limiting the generality of the foregoing:
- (a) it is the express intent of the Association Documents that the various provisions thereof which are enforceable by the Association and which govern or regulate the uses of the properties have been written, and are to be interpreted and enforced, for the sole purpose of enhancing and maintaining the enjoyment of the properties and the value thereof;
 - (b) the Association is not empowered, and has not been created, to act as an entity which enforces or ensures the compliance with the laws of the United States, State of Florida, County, City and/or any other jurisdiction or the prevention of tortious activities; and
 - (c) the provisions of the Association Documents setting forth the uses of assessments which relate to health, safety and/or welfare shall be interpreted and applied only as limitations on the uses of assessment funds and not as creating a duty of the Association to protect or further the health, safety or welfare of any person(s), even if assessment funds are chosen to be used for any such reason.

Each Owner (by virtue of his acceptance of title to his Unit) and each other person having an interest in or lien upon, or making use of, any portion of the properties (by virtue of accepting such interest or lien or making such use) shall be bound by this provision and shall be deemed to have automatically waived any and all rights, claims, demands and causes of action against the Association arising from or connected with any matter for which the liability of the Association has been disclaimed hereby. As used herein, "Association" shall include within its meaning all of Association's directors, officers, committee and board members, employees, agents, contractors (including management

companies), subcontractors, successors and assigns. The provisions hereof shall also inure to the benefit of Developer, which shall be fully protected hereby.

25.13 Liability of the Hotel Unit Owner. Notwithstanding anything contained herein or in any of the exhibits referenced herein or any other document governing or binding the Hotel Unit Owner (collectively, the "Hotel Documents"), the Hotel Unit Owner, except to the extent specifically provided to the contrary herein, shall not be liable or responsible for, or in any manner a guarantor or insurer of, the health, safety or welfare of any Owner, occupant or user of any portion of the Condominium and/or Association Property including, without limitation, Owners and their guests, invitees, agents, servants, contractors or subcontractors or for any property of any such persons. Without limiting the generality of the foregoing:

- (a) it is the express intent of the Hotel Documents that the various provisions thereof which are enforceable by the Hotel Unit Owner and which govern or regulate the uses of the properties have been written, and are to be interpreted and enforced, for the sole purpose of enhancing and maintaining the enjoyment of the properties and the value thereof; and
- (b) the Hotel Unit Owner is not empowered, and does not exist, to act as an entity which enforces or ensures the compliance with the laws of the United States, State of Florida, County and/or any other jurisdiction or the prevention of tortious activities.

Each Owner (by virtue of acceptance of title to a Unit) and each other person having an interest in or lien upon, or making use of, any portion of the properties (by virtue of accepting such interest or lien or making such use) shall be bound by this provision and shall be deemed to have automatically waived any and all rights, claims, demands and causes of action against the Hotel Unit Owner arising from or connected with any matter for which the liability of the Hotel Unit Owner has been disclaimed hereby.

25.14 No Representations or Warranties. NO REPRESENTATIONS OR WARRANTIES OF ANY KIND, EXPRESS OR IMPLIED, HAVE BEEN GIVEN OR MADE BY DEVELOPER, HOTEL OWNER OR ITS OR THEIR AGENTS OR EMPLOYEES IN CONNECTION WITH ANY PORTION OF THE CONDOMINIUM PROPERTY, THE SHARED COMPONENTS, THEIR PHYSICAL CONDITION, ZONING, COMPLIANCE WITH APPLICABLE LAWS, MERCHANTABILITY, HABITABILITY, FITNESS FOR A PARTICULAR PURPOSE, OR IN CONNECTION WITH THE SUBDIVISION, SALE, OPERATION, MAINTENANCE, COST OF MAINTENANCE, TAXES OR REGULATION THEREOF, EXCEPT (A) AS SPECIFICALLY AND EXPRESSLY SET FORTH IN THIS DECLARATION OR IN DOCUMENTS WHICH MAY BE FILED BY DEVELOPER OR HOTEL OWNER FROM TIME TO TIME WITH APPLICABLE REGULATORY AGENCIES, AND (B) AS OTHERWISE REQUIRED BY LAW. AS TO SUCH WARRANTIES WHICH CANNOT BE DISCLAIMED, AND TO OTHER CLAIMS, IF ANY, WHICH CAN BE MADE AS TO THE AFORESAID MATTERS, ALL INCIDENTAL AND CONSEQUENTIAL DAMAGES ARISING THEREFROM ARE HEREBY DISCLAIMED. ALL OWNERS, BY VIRTUE OF ACCEPTANCE OF TITLE TO THEIR RESPECTIVE UNITS (WHETHER FROM THE DEVELOPER OR ANOTHER PARTY) SHALL BE DEEMED TO HAVE AUTOMATICALLY WAIVED ALL OF THE AFORESAID DISCLAIMED WARRANTIES AND INCIDENTAL AND CONSEQUENTIAL DAMAGES.

(Reserved for Clerk of Court)

IN WITNESS WHEREOF, the Developer has caused this Declaration to be duly executed and its corporate seal to be hereunto affixed as of the ____ day of _____, 200__.

Witnessed by:

FONTAINEBLEAU FLORIDA TOWER 3, LLC, a Florida limited liability company

Name: _____

By: _____

Name: _____

Title: _____

(Corporate Seal)

Name: _____

Address: _____

STATE OF FLORIDA)
) ss:
COUNTY OF MIAMI-DADE)

The foregoing instrument was acknowledged before me this ____ day of _____, 200__, by _____, as _____ of FONTAINEBLEAU FLORIDA TOWER 3, LLC, a Florida limited liability company, on behalf of said entity(ies). He/she is personally known to me or produced _____ as identification.

Name: _____

My commission expires:

Notary Public, State of Florida
Commission No. _____

CONSENT OF MORTGAGEE

THIS CONSENT is given as of the ___ day of _____, 200___, by _____ ("Mortgagee"), being the owner and holder of a mortgage (as same may be amended or modified from time to time, and including any and all other documents securing the indebtedness referenced in the mortgage, the "Mortgage") encumbering the Condominium Property described in the foregoing Declaration.

WHEREAS, FONTAINEBLEAU FLORIDA TOWER 3, LLC; a Florida limited liability company ("Developer") has requested Mortgagee to consent to the recording of the Declaration of Fontainebleau III Ocean Club Condominium (the "Declaration").

NOW, THEREFORE, Mortgagee consents to the recordation of the Declaration and agrees that the lien and effect of the Mortgage shall be subject and subordinate to the terms of the Declaration.

Mortgagee makes no warranty or any representation of any kind or nature concerning the Declaration, any of its terms or provisions, or the legal sufficiency thereof, and disavows any such warranty or representation as well as any participation in the development of Fontainebleau III Ocean Club Condominium (the "Condominium"), and does not assume and shall not be responsible for any of the obligations or liabilities of the Developer contained in the Declaration or the prospectus, (if any) or other documents issued in connection with the promotion of the Condominium. None of the representations contained in the prospectus, (if any) or other documents shall be deemed to have been made by Mortgagee, nor shall they be construed to create any obligation on Mortgagee to any person relying thereon. Except only as expressly provided herein, this consent does not affect or impair the rights and remedies of Mortgagee as set forth in the Mortgage or in the Declaration.

Made as of the day and year first above written.

Witnessed by: _____

Name: _____

By: _____

Name: _____

Title: _____

Name: _____

STATE OF _____)

COUNTY OF _____)

SS:

The foregoing instrument was acknowledged before me this ___ day of _____, 200___ by _____ as _____ of _____, on behalf of said _____. He/she is personally known to me or has produced _____ as identification.

Name: _____

My Commission Expires:

Notary Public, State of _____

Commission No. _____

LEGEND:

- PG. • PAGE
- P.B. • PLAT BOOK
- P.O.B. • POINT OF BEGINNING
- P.O.C. • POINT OF COMMENCEMENT
- MOCR. • MIAMI-DADE COUNTY RECORDS
- O.R.B. • OFFICIAL RECORD BOOK
- N.G.V.D. • NATIONAL GEODETIC VERTICAL DATUM
- D.C.R. • DADE COUNTY RECORDS

- SKETCH AND DESCRIPTION -

TOWER III - BASEMENT LEVEL UNITS

- | | | | | | |
|-----|---------------|--------|-----|---------------|--------|
| 11 | N 07°25'11" E | 41.33' | 291 | N 82°34'49" W | 10.33' |
| 21 | S 82°34'49" E | 2.42' | 301 | N 07°25'11" E | 23.00' |
| 31 | N 07°25'11" E | 15.92' | 311 | S 82°34'49" E | 10.33' |
| 41 | N 82°34'49" W | 2.42' | 321 | S 07°25'11" W | 23.00' |
| 51 | N 07°25'11" E | 20.58' | | | |
| 61 | S 82°34'49" E | 5.67' | 331 | N 07°25'11" E | 9.67' |
| 71 | N 07°25'11" E | 37.17' | 341 | S 82°34'49" E | 19.33' |
| 81 | S 82°34'49" E | 13.33' | 351 | N 07°25'11" E | 9.67' |
| 91 | S 07°25'11" W | 7.50' | 361 | S 82°34'49" E | 19.33' |
| 101 | S 82°34'49" E | 20.06' | | | |
| 111 | S 07°25'11" W | 25.33' | | | |
| 121 | N 82°34'39" W | 20.06' | | | |
| 131 | S 07°25'11" W | 19.83' | | | |
| 141 | S 82°34'49" E | 19.90' | | | |
| 151 | S 07°25'11" W | 12.33' | | | |
| 161 | S 82°34'49" E | 36.17' | | | |
| 171 | N 07°25'11" E | 8.33' | | | |
| 181 | S 82°34'49" E | 24.67' | | | |
| 191 | S 07°25'11" W | 17.00' | | | |
| 201 | N 82°34'49" W | 49.17' | | | |
| 211 | S 07°25'11" W | 20.83' | | | |
| 221 | N 82°34'49" W | 9.08' | | | |
| 231 | N 07°25'11" E | 10.33' | | | |
| 241 | N 82°34'49" W | 21.83' | | | |
| 251 | S 07°25'11" W | 10.50' | | | |
| 261 | N 82°34'49" W | 10.17' | | | |
| 271 | S 07°25'11" W | 20.33' | | | |
| 281 | N 82°34'49" W | 9.67' | | | |

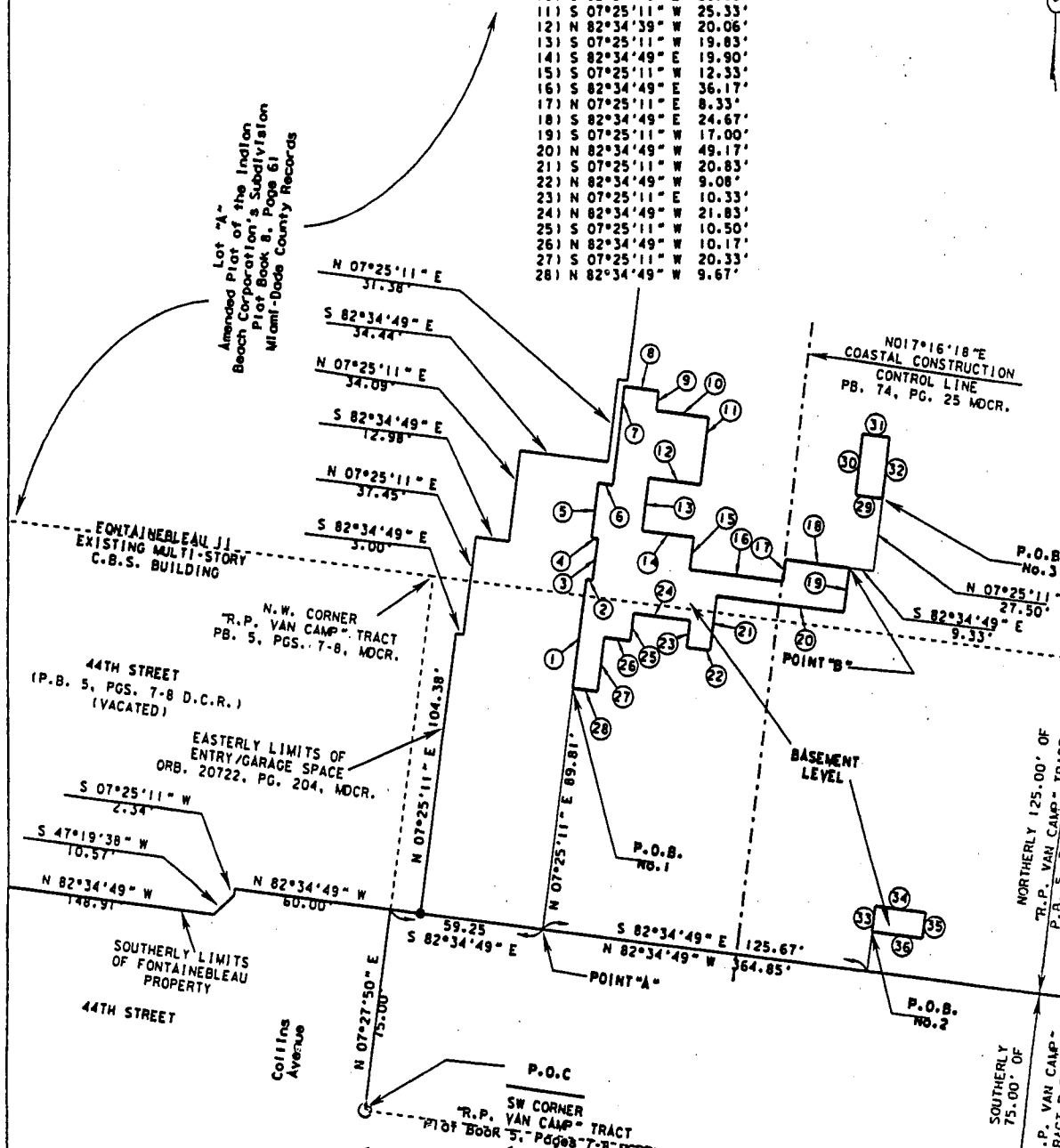

PREPARED BY *Troy N. Townsend* DATE 02-08-05 SEE ATTACHED LEGAL DESCRIPTION SHEET 1 OF 22
 TROY N. TOWNSEND PROFESSIONAL SURVEYOR AND MAPPER No. LS 6425 STATE OF FLORIDA
 NOT VALID WITHOUT THE SIGNATURE AND THE ORIGINAL RAISED SEAL OF A FLORIDA SURVEYOR AND MAPPER.

UPDATES/REVISIONS	DATE	BY	CK'D

NOTE: The undersigned and CONSUL-TECH ENGINEERING, INC. make no representations or warranties as to the completeness of the information reflected herein pertaining to easements, right-of-way, set-back line reservations, agreements or other matters of record. This instrument is intended to reflect or set forth only those items shown in the reference above. CONSUL-TECH ENGINEERING, INC. did not research the public records for matters affecting the lands shown.
 NOTE: This instrument is the property of CONSUL-TECH ENGINEERING, INC. and shall not be reproduced in whole or in part without written permission of CONSUL-TECH ENGINEERING, INC.

- SKETCH AND DESCRIPTION -

LEGAL DESCRIPTION: BASEMENT LEVEL UNITS

A PORTION OF THE NORTHERLY 125.00 FEET OF THAT CERTAIN TRACT MARKED AND DESIGNATED "R.P. VAN CAMP" ON THE "AMENDED MAP OF OCEAN FRONT PROPERTY OF THE MIAMI BEACH IMPROVEMENT COMPANY", AS RECORDED IN PLAT BOOK 5, PAGES 7 AND 8, OF THE PUBLIC RECORDS OF MIAMI-DADE COUNTY, FLORIDA, AND BEING MORE PARTICULARLY DESCRIBED AS FOLLOWS:

THE VERTICALLY ENCLOSED AREA BEGINNING 1.50 FEET ABOVE ELEVATION 0.00 AS PER THE NATIONAL GEODETIC VERTICAL DATUM OF 1929 (NGVD 29) AND EXTENDING 9.58 FEET ABOVE SAID ELEVATION 1.50 FEET TO ELEVATION 11.08 FEET, WHICH SAID ELEVATIONS ARE SET ON THE COURSES SET FORTH BELOW, COMPRISING THE BASEMENT LEVEL.

COMMENCE AT THE SOUTHWEST CORNER OF THE "R.P. VAN CAMP" TRACT AS PER THE "AMENDED MAP OF OCEAN FRONT PROPERTY OF THE MIAMI BEACH IMPROVEMENT COMPANY" ACCORDING TO THE PLAT THEREOF, AS RECORDED IN PLAT BOOK 5, PAGES 7 AND 8 OF THE PUBLIC RECORDS OF MIAMI-DADE COUNTY, FLORIDA; THENCE, NORTH 07°27'50" EAST ALONG THE WESTERLY LINE OF SAID "R.P. VAN CAMP" TRACT, A DISTANCE OF 75.00 FEET TO A POINT ON THE SOUTHERLY LIMITS OF THE FONTAINEBLEAU PROPERTY;

THENCE SOUTH 82°34'49" EAST, ALONG SAID SOUTHERLY LIMITS OF THE FONTAINEBLEAU PROPERTY, A DISTANCE OF 59.25 FEET TO POINT "A";

THENCE NORTH 07°25'11" EAST, A DISTANCE OF 89.81 FEET TO A POINT;

THENCE VERTICALLY FROM AN ELEVATION OF 0.00 FEET TO AN ELEVATION OF 1.50 FEET (N.G.V.D. 29), BEING A VERTICAL DISTANCE OF 1.50 FEET TO POINT OF BEGINNING ONE;

THENCE NORTH 07°25'11" EAST, A DISTANCE OF 41.33 FEET;
 THENCE SOUTH 82°34'49" EAST, A DISTANCE OF 2.42 FEET;
 THENCE NORTH 07°25'11" EAST, A DISTANCE OF 15.92 FEET;
 THENCE NORTH 82°34'49" WEST, A DISTANCE OF 2.42 FEET;
 THENCE NORTH 07°25'11" EAST, A DISTANCE OF 20.58 FEET;
 THENCE SOUTH 82°34'49" EAST, A DISTANCE OF 5.67 FEET;
 THENCE NORTH 07°25'11" EAST, A DISTANCE OF 37.17 FEET;
 THENCE SOUTH 82°34'49" EAST, A DISTANCE OF 13.33 FEET;
 THENCE SOUTH 07°25'11" WEST, A DISTANCE OF 7.50 FEET;
 THENCE SOUTH 82°34'49" EAST, A DISTANCE OF 20.06 FEET;
 THENCE SOUTH 07°25'11" WEST, A DISTANCE OF 25.33 FEET;
 THENCE NORTH 82°34'49" WEST, A DISTANCE OF 20.06 FEET;
 THENCE SOUTH 07°25'11" WEST, A DISTANCE OF 19.83 FEET;
 THENCE SOUTH 82°34'49" EAST, A DISTANCE OF 19.90 FEET;
 THENCE SOUTH 07°25'11" WEST, A DISTANCE OF 12.33 FEET;
 THENCE SOUTH 82°34'49" EAST, A DISTANCE OF 36.17 FEET;
 THENCE NORTH 07°25'11" EAST, A DISTANCE OF 8.33 FEET;
 THENCE SOUTH 82°34'49" EAST, A DISTANCE OF 24.67 FEET TO POINT "B";
 THENCE SOUTH 07°25'11" WEST, A DISTANCE OF 17.00 FEET;
 THENCE NORTH 82°34'49" WEST, A DISTANCE OF 49.17 FEET;
 THENCE SOUTH 07°25'11" WEST, A DISTANCE OF 20.83 FEET;
 THENCE NORTH 82°34'49" WEST, A DISTANCE OF 9.08 FEET;
 THENCE NORTH 07°25'11" EAST, A DISTANCE OF 10.33 FEET;
 THENCE NORTH 82°34'49" WEST, A DISTANCE OF 21.83 FEET;
 THENCE SOUTH 07°25'11" WEST, A DISTANCE OF 10.50 FEET;
 THENCE NORTH 82°34'49" WEST, A DISTANCE OF 10.17 FEET;
 THENCE SOUTH 07°25'11" WEST, A DISTANCE OF 20.33 FEET;
 THENCE NORTH 82°34'49" WEST, A DISTANCE OF 9.67 FEET TO POINT OF BEGINNING ONE.

SEE ATTACHED SKETCH OF DESCRIPTION
SHEET 2 OF 2

PREPARED BY TROY N. TOWNSEND
PROFESSIONAL SURVEYOR AND MAPPER No. LS 6425
STATE OF FLORIDA DATE 02-08-05

NOT VALID WITHOUT THE SIGNATURE AND THE ORIGINAL RAISED SEAL OF A FLORIDA SURVEYOR AND MAPPER

UPDATES / REVISIONS	DATE	BY	CK'D	NOTE
				NOTE: The undersigned and CONSUL-TECH ENGINEERING, INC. make no representations or guarantees as to the completeness of the information reflected hereon pertaining to easements, right-of-way, set-back lines, reservations, agreements or other matters of record. This instrument is intended to reflect or set forth only those items shown in the references above. CONSUL-TECH ENGINEERING, INC. did not research the public records for matters affecting the lands shown. NOTE: This instrument is the property of CONSUL-TECH ENGINEERING, INC. and shall not be reproduced in whole or in part without written permission.

- SKETCH AND DESCRIPTION -

TOGETHER WITH:

A PORTION OF THE NORTHERLY 125.00 FEET OF THAT CERTAIN TRACT MARKED AND DESIGNATED "R.P. VAN CAMP" ON THE "AMENDED MAP OF OCEAN FRONT PROPERTY OF THE MIAMI BEACH IMPROVEMENT COMPANY", AS RECORDED IN PLAT BOOK 5, PAGES 7 AND 8, OF THE PUBLIC RECORDS OF MIAMI-DADE COUNTY, FLORIDA, AND BEING MORE PARTICULARLY DESCRIBED AS FOLLOWS:

THE VERTICALLY ENCLOSED AREA BEGINNING 1.50 FEET ABOVE ELEVATION 0.00 AS PER THE NATIONAL GEODETIC VERTICAL DATUM OF 1929 (NGVD 29) AND EXTENDING 9.58 FEET ABOVE SAID ELEVATION 1.50 FEET TO ELEVATION 11.08 FEET, WHICH SAID ELEVATIONS ARE SET ON THE COURSES SET FORTH BELOW, COMPRISING THE BASEMENT LEVEL.

COMMENCE AT SAID POINT "A";
THENCE SOUTH 82°34'49" EAST, ALONG SAID SOUTHERLY LIMITS OF THE FONTAINEBLEAU PROPERTY, A DISTANCE OF 125.67 FEET TO A POINT;
THENCE NORTH 07°25'11" EAST, A DISTANCE OF 15.00 FEET TO A POINT;
THENCE VERTICALLY FROM AN ELEVATION OF 0.00 FEET TO AN ELEVATION OF 1.50 FEET (N.G.V.D. 29), BEING A VERTICAL DISTANCE OF 1.50 FEET TO POINT OF BEGINNING TWO;

THENCE CONTINUE NORTH 07°25'11" EAST, A DISTANCE OF 9.67 FEET;
THENCE SOUTH 82°34'49" EAST, A DISTANCE OF 19.33 FEET;
THENCE SOUTH 07°25'11" WEST, A DISTANCE OF 9.67 FEET;
THENCE NORTH 82°34'49" WEST, A DISTANCE OF 19.33 FEET TO POINT OF BEGINNING TWO.

AND:

A PORTION OF THE NORTHERLY 125.00 FEET OF THAT CERTAIN TRACT MARKED AND DESIGNATED "R.P. VAN CAMP" ON THE "AMENDED MAP OF OCEAN FRONT PROPERTY OF THE MIAMI BEACH IMPROVEMENT COMPANY", AS RECORDED IN PLAT BOOK 5, PAGES 7 AND 8, OF THE PUBLIC RECORDS OF MIAMI-DADE COUNTY, FLORIDA, AND BEING MORE PARTICULARLY DESCRIBED AS FOLLOWS:

THE VERTICALLY ENCLOSED AREA BEGINNING 1.50 FEET ABOVE ELEVATION 0.00 AS PER THE NATIONAL GEODETIC VERTICAL DATUM OF 1929 (NGVD 29) AND EXTENDING 9.58 FEET ABOVE SAID ELEVATION 1.50 FEET TO ELEVATION 11.08 FEET, WHICH SAID ELEVATIONS ARE SET ON THE COURSES SET FORTH BELOW, COMPRISING THE BASEMENT LEVEL.

COMMENCE AT SAID POINT "B", BEING AT ELEVATION 1.50 FEET;
THENCE SOUTH 82°34'49" EAST, A DISTANCE OF 9.33 FEET;
THENCE NORTH 07°25'11" EAST, A DISTANCE OF 27.50 FEET TO POINT OF BEGINNING THREE;

THENCE NORTH 82°34'49" WEST, A DISTANCE OF 10.33 FEET;
THENCE NORTH 07°25'11" EAST, A DISTANCE OF 23.00 FEET;
THENCE SOUTH 82°34'49" EAST, A DISTANCE OF 10.33 FEET;
THENCE SOUTH 07°25'11" WEST, A DISTANCE OF 23.00 FEET TO POINT OF BEGINNING THREE.

SAID LANDS SITUATE, LYING AND BEING IN THE CITY OF MIAMI BEACH, MIAMI-DADE COUNTY, FLORIDA, AND CONTAINING 4277 SQUARE FEET, MORE OR LESS.

GENERAL NOTES:

1. BEARINGS AS SHOWN HEREON ARE BASED ON THE COASTAL CONSTRUCTION CONTROL LINE AND THE EROSION CONTROL LINE, AS RECORDED IN PLAT BOOK 74, PAGE 25, OF THE PUBLIC RECORDS OF MIAMI-DADE COUNTY FLORIDA, AND BEARING N 07°16'18" E.
2. NO FIELD WORK HAS BEEN PERFORMED DURING THE CREATION OF THIS SKETCH.
3. THIS SKETCH HAS BEEN PRODUCED FOR TURNBERRY ASSOCIATES, INCORPORATED.

SEE ATTACHED SKETCH OF DESCRIPTION SHEET 3 OF 3

PREPARED BY _____
TROY N. TOWNSEND DATE 02-08-05
PROFESSIONAL SURVEYOR AND MAPPER No. LS 6425
STATE OF FLORIDA

NOT VALID WITHOUT THE SIGNATURE AND THE ORIGINAL RAISED SEAL OF A FLORIDA SURVEYOR AND MAPPER

UPDATES/REVISIONS	DATE	BY	CK'D	NOTE
				NOTE: The undersigned and CONSUL-TECH ENGINEERING, INC. make no representations or guarantees as to the completeness of the information reflected hereon pertaining to easements, right-of-way, set-back lines, reservations, agreements or other matters of record. This instrument is intended to reflect or set forth only those items shown in the references above. CONSUL-TECH ENGINEERING, INC. did not research the public records for matters affecting the lands shown. NOTE: This instrument is the property of CONSUL-TECH ENGINEERING, INC. and shall not be reproduced in whole or in part without written permission.

L.B. NO. 7121

LEGEND:

- PG. PAGE
- P.B. PLAT BOOK
- P.O.B. POINT OF BEGINNING
- P.O.C. POINT OF COMMENCEMENT
- MOCR. MIAMI-DADE COUNTY RECORDS
- Q.R.B. OFFICIAL RECORD BOOK
- N.G.V.D. NATIONAL GEODETIC VERTICAL DATUM
- D.C.R. DADE COUNTY RECORDS

- SKETCH AND DESCRIPTION -

TOWER III LOWER LOBBY UNITS

11	N 07°25'11" E	26.34'	271	S 07°25'11" W	17.00'	461	N 07°25'11" E	9.67'
21	S 82°34'49" W	2.21'	281	N 82°34'49" W	2.72'	471	S 82°34'49" E	18.69'
31	N 03°45'28" E	33.66'	291	S 07°25'11" W	9.83'	481	N 07°25'11" E	14.50'
41	N 86°14'32" E	3.76'	301	N 82°34'49" W	17.00'	491	S 82°34'49" E	12.31'
51	N 07°25'11" E	4.41'	311	S 07°25'11" W	23.00'	501	N 07°25'11" E	19.33'
61	N 82°34'49" E	2.17'	321	N 82°34'49" W	7.67'	511	N 82°34'49" W	13.33'
71	N 07°25'11" E	30.17'	331	S 07°25'11" W	6.41'	521	N 07°25'11" E	31.67'
81	S 82°34'49" E	2.17'	341	S 46°47'37" W	16.75'	531	S 82°34'49" E	13.33'
91	N 07°25'11" E	14.54'	351	N 82°34'49" W	6.74'	541	N 07°25'11" E	29.00'
101	S 82°34'49" E	4.00'	361	S 07°25'11" W	5.30'	551	S 82°34'49" E	14.33'
111	N 07°25'11" E	2.71'	371	S 82°34'49" E	3.19'	561	N 07°25'11" W	104.17'
121	S 82°34'49" E	0.83'	381	S 07°25'11" W	43.77'	571	S 82°34'49" W	49.33'
131	N 07°25'11" E	15.61'	391	S 07°25'11" W	11.31'			
141	N 82°34'49" E	0.83'	401	S 07°25'11" W	6.89'			
151	N 07°25'11" E	14.72'	411	N 82°34'49" W	43.91'			
161	S 82°34'49" E	0.53'				581	N 82°34'49" W	30.75'
171	N 07°25'11" E	26.89'	421	S 07°25'11" W	10.00'	591	N 07°25'11" E	20.17'
181	S 82°34'49" E	29.66'	431	N 82°34'49" W	11.33'	601	S 82°34'49" E	30.75'
191	N 07°25'11" E	21.94'	441	N 07°25'11" E	10.00'	611	S 07°25'11" W	20.17'
201	S 82°34'49" E	15.17'	451	S 82°34'49" E	11.33'			
211	S 07°25'11" E	8.33'				621	N 82°34'49" W	10.33'
221	S 82°34'49" E	18.90'				631	N 07°25'11" E	22.99'
231	S 07°25'11" E	23.18'				641	S 82°34'49" E	10.33'
241	N 82°34'49" E	20.17'				651	S 07°25'11" W	22.99'
251	S 07°25'11" E	26.00'						
261	S 82°34'49" E	34.39'						

Lot "A"
 Amended Plat of the Indian
 Beach Corporation's Subdivision
 Plat Book 8, Page 61
 Miami-Dade County Records

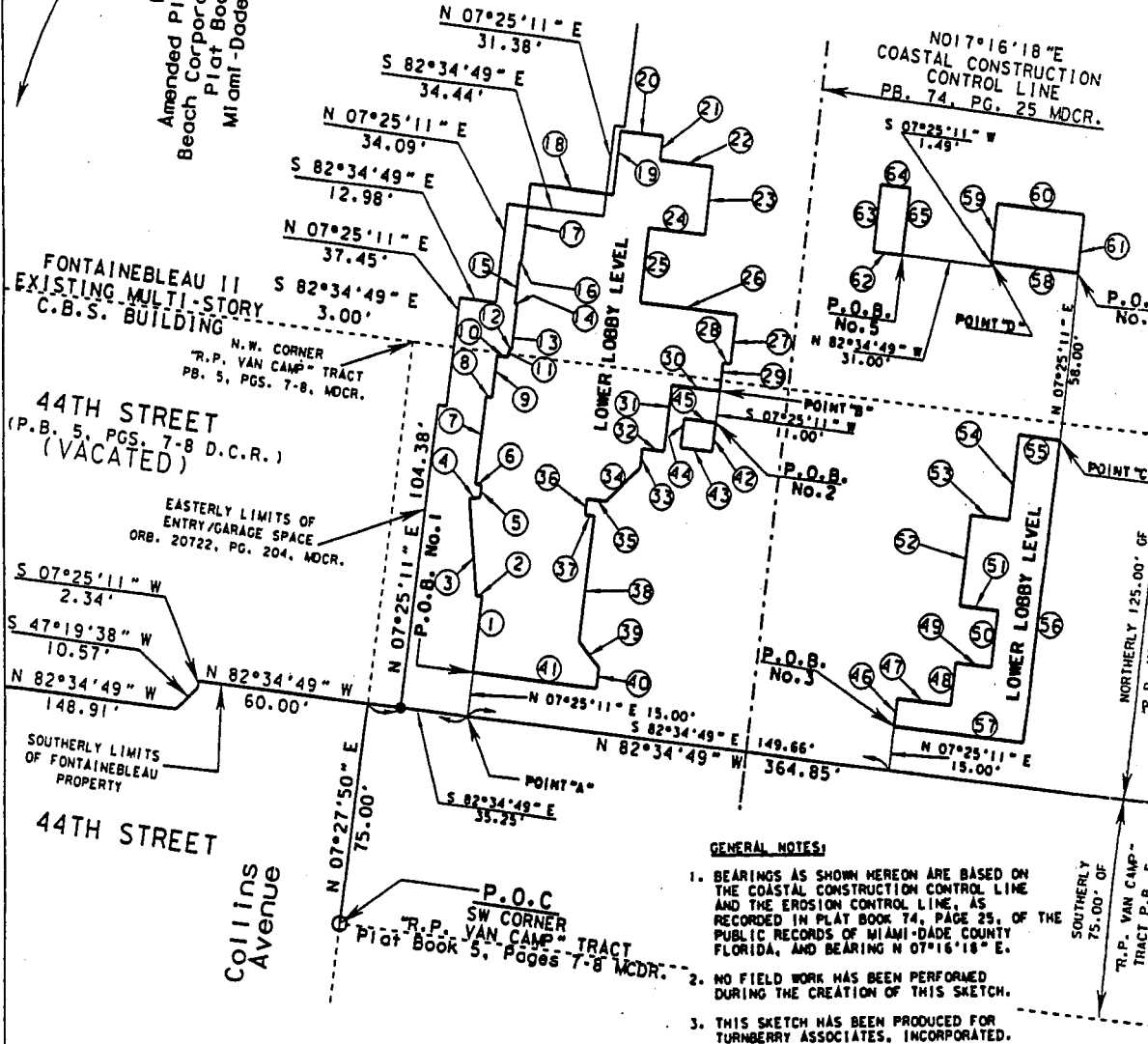

GENERAL NOTES:

- BEARINGS AS SHOWN HEREON ARE BASED ON THE COASTAL CONSTRUCTION CONTROL LINE AND THE EROSION CONTROL LINE, AS RECORDED IN PLAT BOOK 74, PAGE 25, OF THE PUBLIC RECORDS OF MIAMI-DADE COUNTY FLORIDA, AND BEARING N 07°16'18" E.
- NO FIELD WORK HAS BEEN PERFORMED DURING THE CREATION OF THIS SKETCH.
- THIS SKETCH HAS BEEN PRODUCED FOR TURNBERRY ASSOCIATES, INCORPORATED.

PREPARED BY TROY N. TOWNSEND
 PROFESSIONAL SURVEYOR AND MAPPER
 STATE OF FLORIDA
 DATE 02-08-05
 No. LS 6425

SEE ATTACHED LEGAL DESCRIPTION SHEET 4 OF
 NOT VALID WITHOUT THE SIGNATURE AND THE ORIGINAL RAISED SEAL OF A FLORIDA SURVEYOR AND MAPPER.

UPDATES/REVISIONS	DATE	BY	CK'D

NOTE: The undersigned and CONSUL-TECH ENGINEERING, INC. make no representations or guarantees as to the completeness of the information reflected hereon pertaining to easements, right-of-way, set-back lines, reservations, agreements or other matters of record. This instrument is intended to reflect or set forth only those items shown in the reference above. CONSUL-TECH ENGINEERING, INC. did not research the public records for matters affecting the lands shown.
 NOTE: This instrument is the property of CONSUL-TECH ENGINEERING, INC. and shall not be reproduced in whole or in part without written permission.

- SKETCH AND DESCRIPTION -

LEGAL DESCRIPTION: LOWER LOBBY LEVEL UNITS

A PORTION OF THE NORTHERLY 125.00 FEET OF THAT CERTAIN TRACT MARKED AND DESIGNATED "R.P. VAN CAMP" ON THE "AMENDED MAP OF OCEAN FRONT PROPERTY OF THE MIAMI BEACH IMPROVEMENT COMPANY", AS RECORDED IN PLAT BOOK 5, PAGES 7 AND 8, OF THE PUBLIC RECORDS OF MIAMI-DADE COUNTY, FLORIDA, AND BEING MORE PARTICULARLY DESCRIBED AS FOLLOWS:

THE VERTICALLY ENCLOSED AREA BEGINNING 11.08 FEET ABOVE ELEVATION 0.00 AS PER THE NATIONAL GEODETIC VERTICAL DATUM OF 1929 (NGVD 29) AND EXTENDING 10.84 FEET ABOVE SAID ELEVATION 11.08 FEET TO ELEVATION 21.92 FEET, WHICH SAID ELEVATIONS ARE SET ON THE COURSES SET FORTH BELOW, COMPRISING THE LOWER LOBBY LEVEL.

COMMENCE AT THE SOUTHWEST CORNER OF THE "R.P. VAN CAMP" TRACT AS PER THE "AMENDED MAP OF OCEAN FRONT PROPERTY OF THE MIAMI BEACH IMPROVEMENT COMPANY" ACCORDING TO THE PLAT THEREOF, AS RECORDED IN PLAT BOOK 5, PAGES 7 AND 8 OF THE PUBLIC RECORDS OF MIAMI-DADE COUNTY, FLORIDA; THENCE; NORTH 07°27'50" EAST ALONG THE WESTERLY LINE OF SAID "R.P. VAN CAMP" TRACT, A DISTANCE OF 75.00 FEET TO A POINT ON THE SOUTHERLY LIMITS OF THE FONTAINEBLEAU PROPERTY;
 THENCE SOUTH 82°34'49" EAST, ALONG SAID SOUTHERLY LIMITS OF THE FONTAINEBLEAU PROPERTY, A DISTANCE OF 35.25 FEET TO POINT "A";
 THENCE NORTH 07°25'11" EAST, A DISTANCE OF 15.00 FEET TO A POINT;
 THENCE VERTICALLY FROM AN ELEVATION OF 0.00 FEET TO AN ELEVATION OF 11.08 FEET (N.G.V.D. 29), BEING A VERTICAL DISTANCE OF 11.08 FEET TO POINT OF BEGINNING ONE;

THENCE NORTH 07°25'11" EAST, A DISTANCE OF 26.34 FEET;
 THENCE SOUTH 86°14'32" WEST, A DISTANCE OF 2.21 FEET;
 THENCE NORTH 03°45'28" WEST, A DISTANCE OF 33.66 FEET;
 THENCE NORTH 86°14'32" EAST, A DISTANCE OF 3.76 FEET;
 THENCE NORTH 07°25'11" EAST, A DISTANCE OF 4.41 FEET;
 THENCE NORTH 82°34'49" WEST, A DISTANCE OF 2.17 FEET;
 THENCE NORTH 07°25'11" EAST, A DISTANCE OF 30.17 FEET;
 THENCE SOUTH 82°34'49" EAST, A DISTANCE OF 2.17 FEET;
 THENCE NORTH 07°25'11" EAST, A DISTANCE OF 14.54 FEET;
 THENCE SOUTH 82°34'49" EAST, A DISTANCE OF 4.00 FEET;
 THENCE NORTH 07°25'11" EAST, A DISTANCE OF 2.71 FEET;
 THENCE SOUTH 82°34'49" EAST, A DISTANCE OF 0.83 FEET;
 THENCE NORTH 07°25'11" EAST, A DISTANCE OF 15.61 FEET;
 THENCE NORTH 82°34'49" WEST, A DISTANCE OF 0.83 FEET;
 THENCE NORTH 07°25'11" EAST, A DISTANCE OF 14.72 FEET;
 THENCE SOUTH 82°34'49" EAST, A DISTANCE OF 0.53 FEET;
 THENCE NORTH 07°25'11" EAST, A DISTANCE OF 26.89 FEET;
 THENCE SOUTH 82°34'49" EAST, A DISTANCE OF 29.66 FEET;
 THENCE NORTH 07°25'11" EAST, A DISTANCE OF 21.94 FEET;
 THENCE SOUTH 82°34'49" EAST, A DISTANCE OF 15.17 FEET;
 THENCE SOUTH 07°25'11" WEST, A DISTANCE OF 8.33 FEET;
 THENCE SOUTH 82°34'49" EAST, A DISTANCE OF 18.90 FEET;
 THENCE SOUTH 07°25'11" WEST, A DISTANCE OF 23.18 FEET;
 THENCE NORTH 82°34'49" WEST, A DISTANCE OF 20.17 FEET;
 THENCE SOUTH 07°25'11" WEST, A DISTANCE OF 26.00 FEET;
 THENCE SOUTH 82°34'49" EAST, A DISTANCE OF 34.39 FEET;
 THENCE SOUTH 07°25'11" WEST, A DISTANCE OF 17.00 FEET;
 THENCE NORTH 82°34'49" WEST, A DISTANCE OF 2.72 FEET;
 THENCE SOUTH 07°25'11" WEST, A DISTANCE OF 9.83 FEET TO POINT "B";
 THENCE NORTH 82°34'49" WEST, A DISTANCE OF 17.00 FEET;

SEE ATTACHED SKETCH OF DESCRIPTION SHEET 5 OF :

PREPARED BY TROY N. TOWNSEND
 PROFESSIONAL SURVEYOR AND MAPPER No. LS 6425
 STATE OF FLORIDA
 DATE 02-08-05

NOT VALID WITHOUT THE SIGNATURE AND THE ORIGINAL RAISED SEAL OF A FLORIDA SURVEYOR AND MAPPER

UPDATES/REVISIONS	DATE	BY	CK'D

NOTE: The undersigned and CONSUL-TECH ENGINEERING, INC. make no representations or warranties as to the completeness of the information reflected hereon pertaining to easements, right-of-way, set-back lines, reservations, agreements or other matters of record. This instrument is intended to reflect or set forth only those items shown in the reference above. CONSUL-TECH ENGINEERING, INC. did not research the public records for matters affecting the lands shown.
 NOTE: This instrument is the property of CONSUL-TECH ENGINEERING, INC. and shall not be reproduced in whole or in part without written permission.

- SKETCH AND DESCRIPTION -

LEGAL DESCRIPTION: LOWER LOBBY LEVEL UNITS (CONTINUED)

THENCE SOUTH 07°25'11" WEST, A DISTANCE OF 23.00 FEET;
 THENCE NORTH 82°34'49" WEST, A DISTANCE OF 7.67 FEET;
 THENCE SOUTH 07°25'11" WEST, A DISTANCE OF 6.41 FEET;
 THENCE SOUTH 46°47'37" WEST, A DISTANCE OF 16.75 FEET;
 THENCE NORTH 82°34'49" WEST, A DISTANCE OF 6.74 FEET;
 THENCE SOUTH 07°25'11" WEST, A DISTANCE OF 5.30 FEET;
 THENCE SOUTH 82°34'49" EAST, A DISTANCE OF 3.19 FEET;
 THENCE SOUTH 07°25'11" WEST, A DISTANCE OF 43.77 FEET;
 THENCE SOUTH 37°34'46" EAST, A DISTANCE OF 11.31 FEET;
 THENCE SOUTH 07°25'11" WEST, A DISTANCE OF 6.89 FEET;
 THENCE NORTH 82°34'49" WEST, A DISTANCE OF 43.91 FEET; TO
 POINT OF BEGINNING ONE.

TOGETHER WITH:

A PORTION OF THE NORTHERLY 125.00 FEET OF THAT CERTAIN TRACT MARKED AND DESIGNATED "R.P. VAN CAMP" ON THE "AMENDED MAP OF OCEAN FRONT PROPERTY OF THE MIAMI BEACH IMPROVEMENT COMPANY", AS RECORDED IN PLAT BOOK 5, PAGES 7 AND 8, OF THE PUBLIC RECORDS OF MIAMI-DADE COUNTY, FLORIDA, AND BEING MORE PARTICULARLY DESCRIBED AS FOLLOWS:

THE VERTICALLY ENCLOSED AREA BEGINNING 11.08 FEET ABOVE ELEVATION 0.00 AS PER THE NATIONAL GEODETIC VERTICAL DATUM OF 1929 (NGVD 29) AND EXTENDING 10.84 FEET ABOVE SAID ELEVATION 11.08 FEET TO ELEVATION 21.92 FEET, WHICH SAID ELEVATIONS ARE SET ON THE COURSES SET FORTH BELOW, COMPRISING THE LOWER LOBBY LEVEL.

COMMENCE AT SAID POINT "B", BEING AT ELEVATION 11.08 FEET;
 THENCE SOUTH 07°25'11" WEST, A DISTANCE OF 11.00 FEET TO POINT OF BEGINNING TWO;

THENCE CONTINUE SOUTH 07°25'11" WEST, A DISTANCE OF 10.00 FEET;
 THENCE NORTH 82°34'49" WEST, A DISTANCE OF 11.33 FEET;
 THENCE NORTH 07°25'11" EAST, A DISTANCE OF 10.00 FEET;
 THENCE SOUTH 82°34'49" EAST, A DISTANCE OF 11.33 FEET TO POINT OF BEGINNING TWO.

AND:

A PORTION OF THE NORTHERLY 125.00 FEET OF THAT CERTAIN TRACT MARKED AND DESIGNATED "R.P. VAN CAMP" ON THE "AMENDED MAP OF OCEAN FRONT PROPERTY OF THE MIAMI BEACH IMPROVEMENT COMPANY", AS RECORDED IN PLAT BOOK 5, PAGES 7 AND 8, OF THE PUBLIC RECORDS OF MIAMI-DADE COUNTY, FLORIDA, AND BEING MORE PARTICULARLY DESCRIBED AS FOLLOWS:

THE VERTICALLY ENCLOSED AREA BEGINNING 11.08 FEET ABOVE ELEVATION 0.00 AS PER THE NATIONAL GEODETIC VERTICAL DATUM OF 1929 (NGVD 29) AND EXTENDING 10.84 FEET ABOVE SAID ELEVATION 11.08 FEET TO ELEVATION 21.92 FEET, WHICH SAID ELEVATIONS ARE SET ON THE COURSES SET FORTH BELOW, COMPRISING THE LOWER LOBBY LEVEL.

COMMENCE AT SAID POINT "A";
 THENCE SOUTH 82°34'49" EAST, ALONG SAID SOUTHERLY LIMITS OF THE FONTAINEBLEAU PROPERTY, A DISTANCE OF 149.66 FEET;
 THENCE NORTH 07°25'11" EAST, A DISTANCE OF 15.00 FEET TO A POINT;
 THENCE VERTICALLY FROM AN ELEVATION OF 0.00 FEET TO AN ELEVATION OF 11.08 FEET (N.G.V.D. 29), BEING A VERTICAL DISTANCE OF 11.08 FEET TO POINT OF BEGINNING THREE;

SEE ATTACHED SKETCH OF DESCRIPT
 SHEET 6 OF

PREPARED BY _____
 TROY N. TOWNSEND DATE 02-08-05
 PROFESSIONAL SURVEYOR AND MAPPER No. LS 6425
 STATE OF FLORIDA

NOT VALID WITHOUT THE SIGNAT
 AND THE ORIGINAL RAISED SEAL
 A FLORIDA SURVEYOR AND MAPPER

UPDATES/REVISIONS	DATE	BY	CK'D

NOTE: The undersigned and CONSUL-TECH ENGINEERING, INC. make no representations or guarantees as to the completeness of the information reflected hereon pertaining to easements, right-of-way, set-back lines, reservations, agreements or other matters of record. This instrument is intended to reflect or set forth only those items shown in the reference above. CONSUL-TECH ENGINEERING, INC. did not research the public records for matters affecting the lands shown.
 NOTE: This Instrument is the property of CONSUL-TECH ENGINEERING, INC. and shall not be reproduced in whole or in part without written permission.

- SKETCH AND DESCRIPTION -

AND: (CONTINUED)

THENCE NORTH 07°25'11" EAST, A DISTANCE OF 9.67 FEET;
 THENCE SOUTH 82°34'49" EAST, A DISTANCE OF 18.69 FEET;
 THENCE NORTH 07°25'11" EAST, A DISTANCE OF 14.50 FEET;
 THENCE SOUTH 82°34'49" EAST, A DISTANCE OF 12.31 FEET;
 THENCE NORTH 07°25'11" EAST, A DISTANCE OF 19.33 FEET;
 THENCE NORTH 82°34'49" WEST, A DISTANCE OF 13.33 FEET;
 THENCE NORTH 07°25'11" EAST, A DISTANCE OF 31.67 FEET;
 THENCE SOUTH 82°34'49" EAST, A DISTANCE OF 13.33 FEET;
 THENCE NORTH 07°25'11" EAST, A DISTANCE OF 29.00 FEET;
 THENCE SOUTH 82°34'49" EAST, A DISTANCE OF 14.33 FEET TO POINT "C";
 THENCE SOUTH 07°25'11" WEST, A DISTANCE OF 104.17 FEET;
 THENCE NORTH 82°34'49" WEST, A DISTANCE OF 45.33 FEET TO POINT OF BEGINNING THREE.

AND:

A PORTION OF THE NORTHERLY 125.00 FEET OF THAT CERTAIN TRACT MARKED AND DESIGNATED "R.P. VAN CAMP" ON THE "AMENDED MAP OF OCEAN FRONT PROPERTY OF THE MIAMI BEACH IMPROVEMENT COMPANY", AS RECORDED IN PLAT BOOK 5, PAGES 7 AND 8, OF THE PUBLIC RECORDS OF MIAMI-DADE COUNTY, FLORIDA, AND BEING MORE PARTICULARLY DESCRIBED AS FOLLOWS:

THE VERTICALLY ENCLOSED AREA BEGINNING 11.08 FEET ABOVE ELEVATION 0.00 AS PER THE NATIONAL GEODETIC VERTICAL DATUM OF 1929 (NGVD 29) AND EXTENDING 10.84 FEET ABOVE SAID ELEVATION 11.08 FEET TO ELEVATION 21.92 FEET, WHICH SAID ELEVATIONS ARE SET ON THE COURSES SET FORTH BELOW, COMPRISING THE LOWER LOBBY LEVEL.

COMMENCE AT SAID POINT "C", BEING AT ELEVATION 11.08 FEET;
 THENCE NORTH 07°25'11" EAST, A DISTANCE OF 58.00 FEET TO POINT OF BEGINNING FOUR;

THENCE NORTH 82°34'49" WEST, A DISTANCE OF 30.75 FEET TO POINT "D";
 THENCE NORTH 07°25'11" EAST, A DISTANCE OF 20.17 FEET;
 THENCE SOUTH 82°34'49" EAST, A DISTANCE OF 30.75 FEET;
 THENCE SOUTH 07°25'11" WEST, A DISTANCE OF 20.17 FEET TO POINT OF BEGINNING FOUR.

AND:

A PORTION OF THE NORTHERLY 125.00 FEET OF THAT CERTAIN TRACT MARKED AND DESIGNATED "R.P. VAN CAMP" ON THE "AMENDED MAP OF OCEAN FRONT PROPERTY OF THE MIAMI BEACH IMPROVEMENT COMPANY", AS RECORDED IN PLAT BOOK 5, PAGES 7 AND 8, OF THE PUBLIC RECORDS OF MIAMI-DADE COUNTY, FLORIDA, AND BEING MORE PARTICULARLY DESCRIBED AS FOLLOWS:

THE VERTICALLY ENCLOSED AREA BEGINNING 11.08 FEET ABOVE ELEVATION 0.00 AS PER THE NATIONAL GEODETIC VERTICAL DATUM OF 1929 (NGVD 29) AND EXTENDING 10.84 FEET ABOVE SAID ELEVATION 11.08 FEET TO ELEVATION 21.92 FEET, WHICH SAID ELEVATIONS ARE SET ON THE COURSES SET FORTH BELOW, COMPRISING THE LOWER LOBBY LEVEL.

COMMENCE AT SAID POINT "D", BEING AT ELEVATION 11.08 FEET;
 THENCE SOUTH 07°25'11" WEST, A DISTANCE OF 1.49 FEET;
 THENCE NORTH 82°34'49" WEST, A DISTANCE OF 31.00 FEET TO POINT OF BEGINNING FIVE;

THENCE CONTINUE NORTH 82°34'49" WEST, A DISTANCE OF 10.33;
 THENCE NORTH 07°25'11" EAST, A DISTANCE OF 22.99 FEET;
 THENCE SOUTH 82°34'49" EAST, A DISTANCE OF 10.33 FEET;
 THENCE SOUTH 07°25'11" WEST, A DISTANCE OF 22.99 FEET TO POINT OF BEGINNING FIVE.

SAID LANDS SITUATE, LYING AND BEING IN THE CITY OF MIAMI BEACH, MIAMI-DADE COUNTY, FLORIDA, AND CONTAINING 12,856 SQUARE FEET, MORE OR LESS.

PREPARED BY _____ DATE 02-08-05
 TROY N. TOWNSEND
 PROFESSIONAL SURVEYOR AND MAPPER No. LS 6425
 STATE OF FLORIDA

SEE ATTACHED SKETCH OF DESCRIPTION SHEET 7 OF
 NOT VALID WITHOUT THE SIGNATURE
 AND THE ORIGINAL RAISED SEAL
 OF A FLORIDA SURVEYOR AND MAPPER

UPDATES/REVISIONS	DATE	BY	CK'D

NOTE: The undersigned and CONSUL-TECH ENGINEERING, INC. make no representations or guarantees as to the completeness of the information reflected hereon pertaining to easements, right-of-way, set-back lines, reservations, agreements or other matters of record. This instrument is intended to reflect or set forth only those items shown in the references above. CONSUL-TECH ENGINEERING, INC. did not research the public records for matters affecting the lands shown.
 NOTE: This instrument is the property of CONSUL-TECH ENGINEERING, INC. and shall not be reproduced in whole or in part without written permission.

L.B. NO. 7121

- SKETCH AND DESCRIPTION -

LEGEND:

- PG. = PAGE
- P.B. = PLAT BOOK
- P.O.B. = POINT OF BEGINNING
- P.O.C. = POINT OF COMMENCEMENT
- MDCR. = MIAMI-DADE COUNTY RECORDS
- O.R.B. = OFFICIAL RECORD BOOK
- N.G.V.D. = NATIONAL GEODETIC VERTICAL DATUM
- D.C.R. = DADE COUNTY RECORDS

TOWER III - LOBBY LEVEL UNITS

11	N 07°25'11" E	26.34'	291	S 07°25'11" W	20.83'
21	S 86°14'32" W	2.21'	301	S 82°34'49" E	7.83'
31	N 03°45'28" W	33.66'	311	S 07°25'11" W	12.00'
41	N 86°14'32" E	3.76'	321	N 82°34'49" W	16.75'
51	N 07°25'11" E	4.41'	331	S 52°19'25" W	12.73'
61	N 82°34'49" W	2.17'	341	N 82°34'49" W	4.33'
71	N 07°25'11" E	30.17'	351	S 07°25'11" W	6.18'
81	S 82°34'49" E	2.17'	361	S 52°25'11" W	4.91'
91	N 07°25'11" E	14.75'	371	N 82°34'49" W	18.34'
101	S 82°34'49" E	4.00'	381	S 07°25'11" W	20.35'
111	N 07°25'11" E	2.50'	391	N 82°34'49" W	9.35'
121	S 82°34'39" E	0.83'	401	S 07°25'11" W	14.33'
131	N 07°25'11" E	15.67'	411	N 82°34'49" E	3.39'
141	N 82°34'49" W	0.83'	421	S 07°25'11" W	19.83'
151	N 07°25'11" E	14.67'	431	S 82°34'49" E	5.67'
161	S 82°34'49" W	0.58'	441	S 07°25'11" W	10.17'
171	N 07°25'11" E	26.64'	451	N 82°34'49" W	21.34'
181	S 82°34'49" E	22.60'			
191	N 07°25'11" E	15.17'	461	N 07°25'11" E	9.67'
201	S 82°34'49" E	18.90'	471	S 82°34'49" E	19.33'
211	S 07°25'11" W	8.33'	481	S 07°25'11" W	9.67'
221	S 82°34'49" E	18.90'	491	N 82°34'49" W	9.67'
231	S 07°25'11" W	49.17'			
241	S 82°34'49" E	1.00'	501	N 07°25'11" E	9.83'
251	S 07°25'11" W	9.00'	511	S 82°34'49" E	13.00'
261	N 82°34'49" W	2.83'	521	S 07°25'11" W	9.83'
271	S 07°25'11" W	8.00'	531	N 82°34'49" W	13.00'
281	S 82°34'49" E	4.25'			

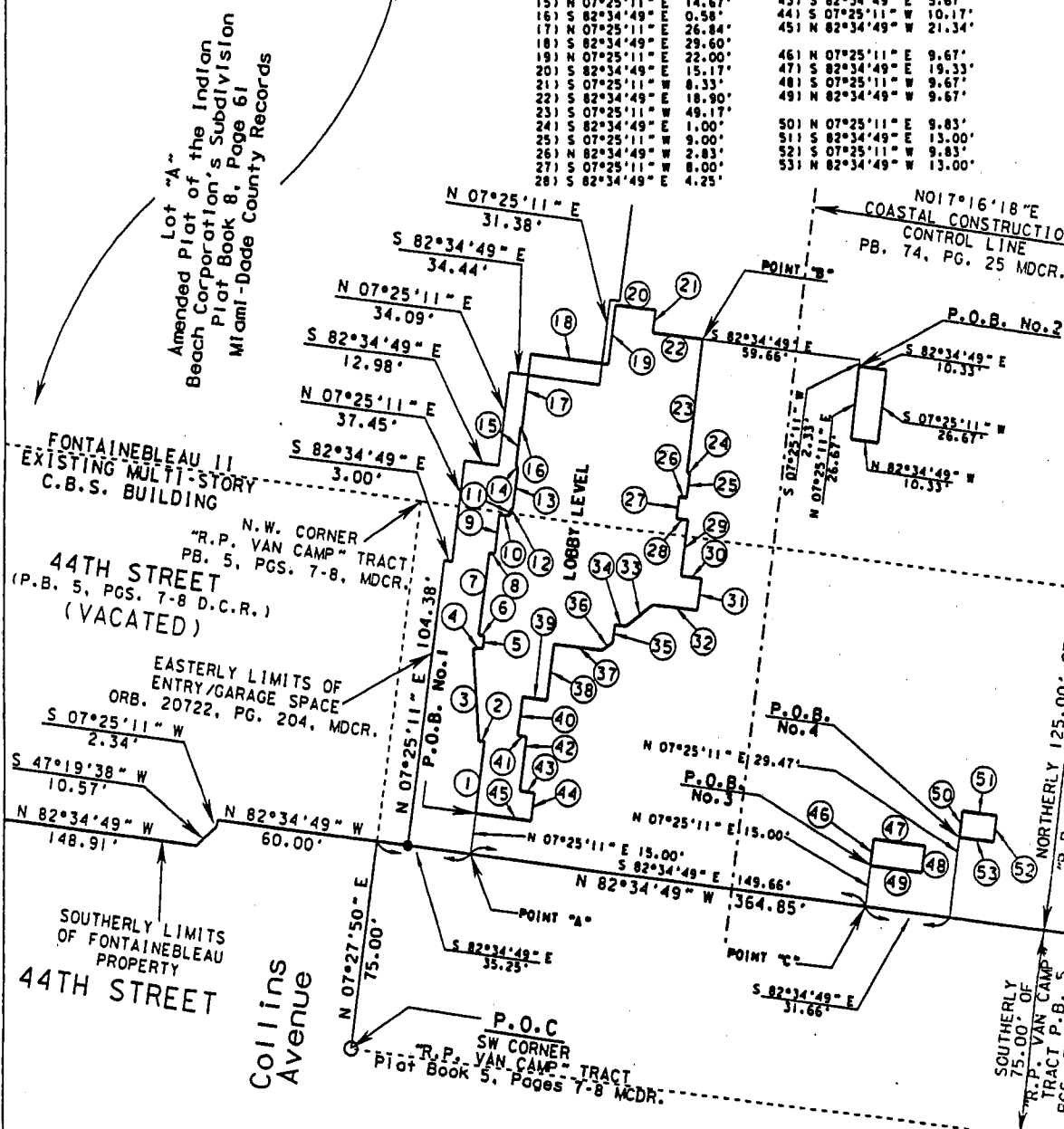

PREPARED BY TROY N. TOWNSEND DATE 02-08-05
 PROFESSIONAL SURVEYOR AND MAPPER No. LS 6425
 STATE OF FLORIDA

SEE ATTACHED LEGAL DESCRIPTION SHEET 8 OF
 NOT VALID WITHOUT THE SIGNATURE AND THE ORIGINAL RAISED SEAL OF A FLORIDA SURVEYOR AND MAPPER.

UPDATES/REVISIONS	DATE	BY	CK'D

NOTE: The undersigned and CONSUL-TECH ENGINEERING, INC. make no representations or guarantees as to the completeness of the information reflected hereon pertaining to easements, right-of-way, set-back line reservations, agreements or other matters of record. This instrument is intended to reflect or set forth only those items shown in the reference above. CONSUL-TECH ENGINEERING, INC. did not research the public records for matters affecting the lands shown.

NOTE: This instrument is the property of CONSUL-TECH ENGINEERING, INC. and shall not be reproduced in whole or in part without written permission.

- SKETCH AND DESCRIPTION -

LEGAL DESCRIPTION: LOBBY LEVEL UNITS

A PORTION OF THE NORTHERLY 125.00 FEET OF THAT CERTAIN TRACT MARKED AND DESIGNATED "R.P. VAN CAMP" ON THE "AMENDED MAP OF OCEAN FRONT PROPERTY OF THE MIAMI BEACH IMPROVEMENT COMPANY", AS RECORDED IN PLAT BOOK 5, PAGES 7 AND 8, OF THE PUBLIC RECORDS OF MIAMI-DADE COUNTY, FLORIDA, AND BEING MORE PARTICULARLY DESCRIBED AS FOLLOWS:

THE VERTICALLY ENCLOSED AREA BEGINNING 21.92 FEET ABOVE ELEVATION 0.00 AS PER THE NATIONAL GEODETIC VERTICAL DATUM OF 1929 (NGVD 29) AND EXTENDING 16.83 FEET ABOVE SAID ELEVATION 21.92 FEET TO ELEVATION 38.75 FEET, WHICH SAID ELEVATIONS ARE SET ON THE COURSES SET FORTH BELOW, COMPRISING THE LOBBY LEVEL.

COMMENCE AT THE SOUTHWEST CORNER OF THE "R.P. VAN CAMP" TRACT AS PER THE "AMENDED MAP OF OCEAN FRONT PROPERTY OF THE MIAMI BEACH IMPROVEMENT COMPANY" ACCORDING TO THE PLAT THEREOF, AS RECORDED IN PLAT BOOK 5, PAGES 7 AND 8 OF THE PUBLIC RECORDS OF MIAMI-DADE COUNTY, FLORIDA; THENCE; NORTH 07°27'50" EAST ALONG THE WESTERLY LINE OF SAID "R.P. VAN CAMP" TRACT, A DISTANCE OF 75.00 FEET TO A POINT ON THE SOUTHERLY LIMITS OF THE FONTAINEBLEAU PROPERTY;

THENCE SOUTH 82°34'49" EAST, ALONG SAID SOUTHERLY LIMITS OF THE FONTAINEBLEAU PROPERTY, A DISTANCE OF 35.25 FEET TO POINT "A";

THENCE NORTH 07°25'11" EAST, A DISTANCE OF 15.00 FEET TO A POINT;

THENCE VERTICALLY FROM AN ELEVATION OF 0.00 FEET TO AN ELEVATION OF 21.92 FEET (N.G.V.D. 29), BEING A VERTICAL DISTANCE OF 21.92 FEET TO POINT OF BEGINNING ONE;

- THENCE NORTH 07°25'11" EAST, A DISTANCE OF 26.34 FEET;
- THENCE SOUTH 86°14'32" WEST, A DISTANCE OF 2.21 FEET;
- THENCE NORTH 03°45'28" WEST, A DISTANCE OF 33.66 FEET;
- THENCE NORTH 86°14'32" EAST, A DISTANCE OF 3.76 FEET;
- THENCE NORTH 07°25'11" EAST, A DISTANCE OF 4.41 FEET;
- THENCE NORTH 82°34'49" WEST, A DISTANCE OF 2.17 FEET;
- THENCE NORTH 07°25'11" EAST, A DISTANCE OF 30.17 FEET;
- THENCE SOUTH 82°34'49" EAST, A DISTANCE OF 2.17 FEET;
- THENCE NORTH 07°25'11" EAST, A DISTANCE OF 14.75 FEET;
- THENCE SOUTH 82°34'49" EAST, A DISTANCE OF 4.00 FEET;
- THENCE NORTH 07°25'11" EAST, A DISTANCE OF 2.50 FEET;
- THENCE SOUTH 82°34'49" EAST, A DISTANCE OF 0.83 FEET;
- THENCE NORTH 07°25'11" EAST, A DISTANCE OF 15.67 FEET;
- THENCE NORTH 82°34'49" WEST, A DISTANCE OF 0.83 FEET;
- THENCE NORTH 07°25'11" EAST, A DISTANCE OF 14.67 FEET;
- THENCE SOUTH 82°34'49" EAST, A DISTANCE OF 0.58 FEET;
- THENCE NORTH 07°25'11" EAST, A DISTANCE OF 26.84 FEET;
- THENCE SOUTH 82°34'49" EAST, A DISTANCE OF 29.60 FEET;
- THENCE NORTH 07°25'11" EAST, A DISTANCE OF 22.00 FEET;
- THENCE SOUTH 82°34'49" EAST, A DISTANCE OF 15.17 FEET;
- THENCE SOUTH 07°25'11" WEST, A DISTANCE OF 8.33 FEET;
- THENCE SOUTH 82°34'49" EAST, A DISTANCE OF 18.90 FEET TO POINT "B";
- THENCE SOUTH 07°25'11" WEST, A DISTANCE OF 49.17 FEET;
- THENCE SOUTH 82°34'49" EAST, A DISTANCE OF 1.00 FEET;
- THENCE SOUTH 07°25'11" WEST, A DISTANCE OF 9.00 FEET;
- THENCE NORTH 82°34'49" WEST, A DISTANCE OF 2.83 FEET;
- THENCE SOUTH 07°25'11" WEST, A DISTANCE OF 8.00 FEET;
- THENCE SOUTH 82°34'49" EAST, A DISTANCE OF 4.25 FEET;
- THENCE SOUTH 07°25'11" WEST, A DISTANCE OF 20.83 FEET;
- THENCE SOUTH 82°34'49" EAST, A DISTANCE OF 7.83 FEET;

SEE ATTACHED SKETCH OF DESCRIPTIVE SHEET 9 OF :

PREPARED BY _____
TROY N. TOWNSEND DATE 02-08-05
PROFESSIONAL SURVEYOR AND MAPPER No. LS 6425
STATE OF FLORIDA

NOT VALID WITHOUT THE SIGNATURE AND THE ORIGINAL RAISED SEAL OF A FLORIDA SURVEYOR AND MAPPER

UPDATES/REVISIONS	DATE	BY	CK'D

NOTE: The undersigned and CONSUL-TECH ENGINEERING, INC. make no representations or guarantees as to the completeness of the information reflected hereon pertaining to easements, right-of-way, set-back lines, reservations, agreements or other matters of record. This instrument is intended to reflect or set forth only those items shown in the reference above. CONSUL-TECH ENGINEERING, INC. did not research the public records for matters affecting the lands shown.
NOTE: This instrument is the property of CONSUL-TECH ENGINEERING, INC.

- SKETCH AND DESCRIPTION -

LEGAL DESCRIPTION: LOBBY LEVEL UNITS (CONTINUED)

THENCE SOUTH 07°25'11" WEST, A DISTANCE OF 12.00 FEET;
 THENCE NORTH 82°34'49" WEST, A DISTANCE OF 16.75 FEET;
 THENCE SOUTH 52°19'25" WEST, A DISTANCE OF 12.73 FEET;
 THENCE NORTH 82°34'49" WEST, A DISTANCE TO 4.33 FEET;
 THENCE SOUTH 07°25'11" WEST, A DISTANCE OF 6.18 FEET;
 THENCE SOUTH 52°25'11" WEST, A DISTANCE OF 4.91 FEET;
 THENCE NORTH 82°34'49" WEST, A DISTANCE OF 18.34 FEET;
 THENCE SOUTH 07°25'11" WEST, A DISTANCE OF 20.35 FEET;
 THENCE NORTH 82°34'49" WEST, A DISTANCE OF 9.35 FEET;
 THENCE SOUTH 07°25'11" WEST, A DISTANCE OF 14.33 FEET;
 THENCE SOUTH 82°34'49" EAST, A DISTANCE OF 3.39 FEET;
 THENCE SOUTH 07°25'11" WEST, A DISTANCE OF 19.83 FEET;
 THENCE SOUTH 82°34'49" EAST, A DISTANCE OF 5.67 FEET;
 THENCE SOUTH 07°25'11" WEST, A DISTANCE OF 10.17 FEET;
 THENCE NORTH 82°34'49" WEST, A DISTANCE OF 21.34 FEET TO POINT OF BEGINNING ONE.

TOGETHER WITH:

A PORTION OF THE NORTHERLY 125.00 FEET OF THAT CERTAIN TRACT MARKED AND DESIGNATED "R.P. VAN CAMP" ON THE "AMENDED MAP OF OCEAN FRONT PROPERTY OF THE MIAMI BEACH IMPROVEMENT COMPANY", AS RECORDED IN PLAT BOOK 5, PAGES 7 AND 8, OF THE PUBLIC RECORDS OF MIAMI-DADE COUNTY, FLORIDA, AND BEING MORE PARTICULARLY DESCRIBED AS FOLLOWS:

THE VERTICALLY ENCLOSED AREA BEGINNING 21.92 FEET ABOVE ELEVATION 0.00 AS PER THE NATIONAL GEODETIC VERTICAL DATUM OF 1929 (NGVD 29) AND EXTENDING 16.83 FEET ABOVE SAID ELEVATION 21.92 FEET TO ELEVATION 38.75 FEET, WHICH SAID ELEVATIONS ARE SET ON THE COURSES SET FORTH BELOW, COMPRISING THE LOBBY LEVEL.

COMMENCE AT SAID POINT "B", BEING AT ELEVATION 21.92 FEET;
 THENCE SOUTH 82°34'49" EAST, A DISTANCE OF 59.66 FEET;
 THENCE SOUTH 07°25'11" WEST, A DISTANCE OF 2.33 FEET TO POINT OF BEGINNING TWO;

THENCE SOUTH 82°34'49" EAST, A DISTANCE OF 10.33 FEET;
 THENCE SOUTH 07°25'11" WEST, A DISTANCE OF 26.67 FEET;
 THENCE NORTH 82°34'49" WEST, A DISTANCE OF 10.33 FEET;
 THENCE NORTH 07°25'11" EAST, A DISTANCE OF 26.67 FEET TO POINT OF BEGINNING TWO.

AND:

A PORTION OF THE NORTHERLY 125.00 FEET OF THAT CERTAIN TRACT MARKED AND DESIGNATED "R.P. VAN CAMP" ON THE "AMENDED MAP OF OCEAN FRONT PROPERTY OF THE MIAMI BEACH IMPROVEMENT COMPANY", AS RECORDED IN PLAT BOOK 5, PAGES 7 AND 8, OF THE PUBLIC RECORDS OF MIAMI-DADE COUNTY, FLORIDA, AND BEING MORE PARTICULARLY DESCRIBED AS FOLLOWS:

THE VERTICALLY ENCLOSED AREA BEGINNING 21.92 FEET ABOVE ELEVATION 0.00 AS PER THE NATIONAL GEODETIC VERTICAL DATUM OF 1929 (NGVD 29) AND EXTENDING 16.83 FEET ABOVE SAID ELEVATION 21.92 FEET TO ELEVATION 38.75 FEET, WHICH SAID ELEVATIONS ARE SET ON THE COURSES SET FORTH BELOW, COMPRISING THE LOBBY LEVEL.

COMMENCE AT SAID POINT "A",
 THENCE SOUTH 82°34'49" EAST, ALONG THE SOUTHERLY LINE OF SAID FONTAINEBLEAU PROPERTY, A DISTANCE OF 149.66 FEET TO POINT "C";
 THENCE NORTH 07°25'11" EAST, A DISTANCE OF 15.00 FEET TO A POINT;
 THENCE VERTICALLY FROM AN ELEVATION OF 0.00 FEET TO AN ELEVATION OF 21.92 FEET (N.G.V.D. 29), BEING A VERTICAL DISTANCE OF 21.92 FEET TO POINT OF BEGINNING THREE;

SEE ATTACHED SKETCH OF DESCRIPTIVE SHEET 10 OF 2

PREPARED BY _____ DATE 02-08-05
 TROY N. TOWNSEND
 PROFESSIONAL SURVEYOR AND MAPPER No. LS 6425
 STATE OF FLORIDA

NOT VALID WITHOUT THE SIGNATURE AND THE ORIGINAL RAISED SEAL OF A FLORIDA SURVEYOR AND MAPPER.

UPDATES/REVISIONS	DATE	BY	CK'D

NOTE: The undersigned and CONSUL-TECH ENGINEERING, INC. make no representations or guarantees as to the completeness of the information reflected hereon pertaining to easements, right-of-way, set-back lines, reservations, agreements or other matters of record. This instrument is intended to reflect or set forth only those items shown in the reference above. CONSUL-TECH ENGINEERING, INC. did not research the public records for matters affecting the lands shown.
 NOTE: This instrument is the property of CONSUL-TECH ENGINEERING, INC. and shall not be reproduced in whole or in part without written permission.

- SKETCH AND DESCRIPTION -

AND: (CONTINUED)

THENCE NORTH 07°25'11" EAST, A DISTANCE OF 9.67 FEET;
THENCE SOUTH 82°34'49" EAST, A DISTANCE OF 19.33 FEET;
THENCE SOUTH 07°25'11" WEST, A DISTANCE OF 9.67 FEET;
THENCE NORTH 82°34'49" WEST, A DISTANCE OF 19.33 FEET TO POINT OF BEGINNING THREE.

AND:

A PORTION OF THE NORTHERLY 125.00 FEET OF THAT CERTAIN TRACT MARKED AND DESIGNATED "R.P. VAN CAMP" ON THE "AMENDED MAP OF OCEAN FRONT PROPERTY OF THE MIAMI BEACH IMPROVEMENT COMPANY", AS RECORDED IN PLAT BOOK 5, PAGES 7 AND 8, OF THE PUBLIC RECORDS OF MIAMI-DADE COUNTY, FLORIDA, AND BEING MORE PARTICULARLY DESCRIBED AS FOLLOWS:

THE VERTICALLY ENCLOSED AREA BEGINNING 21.92 FEET ABOVE ELEVATION 0.00 AS PER THE NATIONAL GEODETIC VERTICAL DATUM OF 1929 (NGVD 29) AND EXTENDING 16.83 FEET ABOVE SAID ELEVATION 21.92 FEET TO ELEVATION 38.75 FEET, WHICH SAID ELEVATIONS ARE SET ON THE COURSES SET FORTH BELOW, COMPRISING THE LOBBY LEVEL.

COMMENCE AT SAID POINT "C".

THENCE SOUTH 82°34'49" EAST, ALONG THE SOUTHERLY LINE OF SAID FONTAINEBLEAU PROPERTY, A DISTANCE OF 31.66 FEET;
THENCE NORTH 07°25'11" EAST, A DISTANCE OF 29.47 FEET TO A POINT;
THENCE VERTICALLY FROM AN ELEVATION OF 0.00 FEET TO AN ELEVATION OF 21.92 FEET (N.G.V.D. 29), BEING A VERTICAL DISTANCE OF 21.92 FEET TO POINT OF BEGINNING FOUR;

THENCE NORTH 07°25'11" EAST, A DISTANCE OF 9.83 FEET;
THENCE SOUTH 82°34'49" EAST, A DISTANCE OF 13.00 FEET;
THENCE SOUTH 07°25'11" WEST, A DISTANCE OF 9.83 FEET;
THENCE NORTH 82°34'49" WEST, A DISTANCE OF 13.00 FEET TO POINT OF BEGINNING FOUR.

SAID LANDS SITUATE, LYING AND BEING IN THE CITY OF MIAMI BEACH, MIAMI-DADE COUNTY, FLORIDA, AND CONTAINING 9,302 SQUARE FEET, MORE OR LESS.

GENERAL NOTES:

1. BEARINGS AS SHOWN HEREON ARE BASED ON THE COASTAL CONSTRUCTION CONTROL LINE AND THE EROSION CONTROL LINE, AS RECORDED IN PLAT BOOK 74, PAGE 25, OF THE PUBLIC RECORDS OF MIAMI-DADE COUNTY FLORIDA, AND BEARING N 07°16'18" E.
2. NO FIELD WORK HAS BEEN PERFORMED DURING THE CREATION OF THIS SKETCH.
3. THIS SKETCH HAS BEEN PRODUCED FOR TURNBERRY ASSOCIATES, INCORPORATED.

SEE ATTACHED SKETCH OF DESCRIPTION SHEET 11 OF 11

PREPARED BY _____ DATE 02-08-05
TROY N. TOWNSEND
PROFESSIONAL SURVEYOR AND MAPPER No. LS 6425
STATE OF FLORIDA

NOT VALID WITHOUT THE SIGNATURE AND THE ORIGINAL RAISED SEAL OF A FLORIDA SURVEYOR AND MAPPER

UPDATES/REVISIONS	DATE	BY	CK'D

NOTE: The undersigned and CONSUL-TECH ENGINEERING, INC. make no representations or guarantees as to the completeness of the information reflected hereon pertaining to easements, right-of-way, set-back lines, reservations, agreements or other matters of record. This instrument is intended to reflect or set forth only those items shown in the reference above. CONSUL-TECH ENGINEERING, INC. did not research the public records for matters affecting the lands shown.
NOTE: This instrument is the property of CONSUL-TECH ENGINEERING, INC. and shall not be reproduced in whole or in part without written permission.

L.B. NO. 7121

LEGEND:

- PG. = PAGE
- P.B. = PLAT BOOK
- P.O.B. = POINT OF BEGINNING
- P.O.C. = POINT OF COMMENCEMENT
- MDCR. = MIAMI-DADE COUNTY RECORDS
- O.R.B. = OFFICIAL RECORD BOOK
- N.G.V.D. = NATIONAL GEODETIC VERTICAL DATUM
- D.C.R. = DADE COUNTY RECORDS

- SKETCH AND DESCRIPTION -

TOWER III - UPPER LOBBY LEVEL UNITS

- | | |
|---------------------------|---------------------------|
| 11) N 07°25'11" E 48.92' | 271) N 07°25'11" E 26.67' |
| 21) N 82°34'49" W 5.00' | 281) S 82°34'49" E 10.33' |
| 31) N 07°25'11" E 5.50' | 291) S 07°25'11" W 26.67' |
| 41) N 82°34'49" W 1.83' | 301) N 82°34'49" W 10.33' |
| 51) N 07°25'11" E 16.00' | |
| 61) S 82°34'49" E 1.83' | 311) N 07°25'11" E 9.67' |
| 71) N 07°25'11" E 22.25' | 321) S 82°34'49" E 19.33' |
| 81) N 82°34'49" W 0.67' | 331) S 07°25'11" W 9.67' |
| 91) N 07°25'11" E 6.83' | 341) N 82°34'49" W 19.33' |
| 101) S 82°34'49" E 4.66' | |
| 111) N 07°25'11" E 1.83' | |
| 121) S 82°34'39" E 17.00' | |
| 131) S 07°25'11" W 4.31' | |
| 141) S 82°34'49" E 8.00' | |
| 151) S 07°25'11" W 34.69' | |
| 161) S 82°34'49" E 8.67' | |
| 171) S 07°25'11" W 7.81' | |
| 181) W 82°34'49" W 11.06' | |
| 191) S 07°25'11" W 19.35' | |
| 201) N 82°34'49" W 4.60' | |
| 211) S 07°25'11" W 1.00' | |
| 221) N 82°34'49" W 9.58' | |
| 231) S 07°25'11" W 17.33' | |
| 241) S 82°34'49" E 7.08' | |
| 251) S 07°25'11" W 16.83' | |
| 261) N 82°34'49" W 14.50' | |

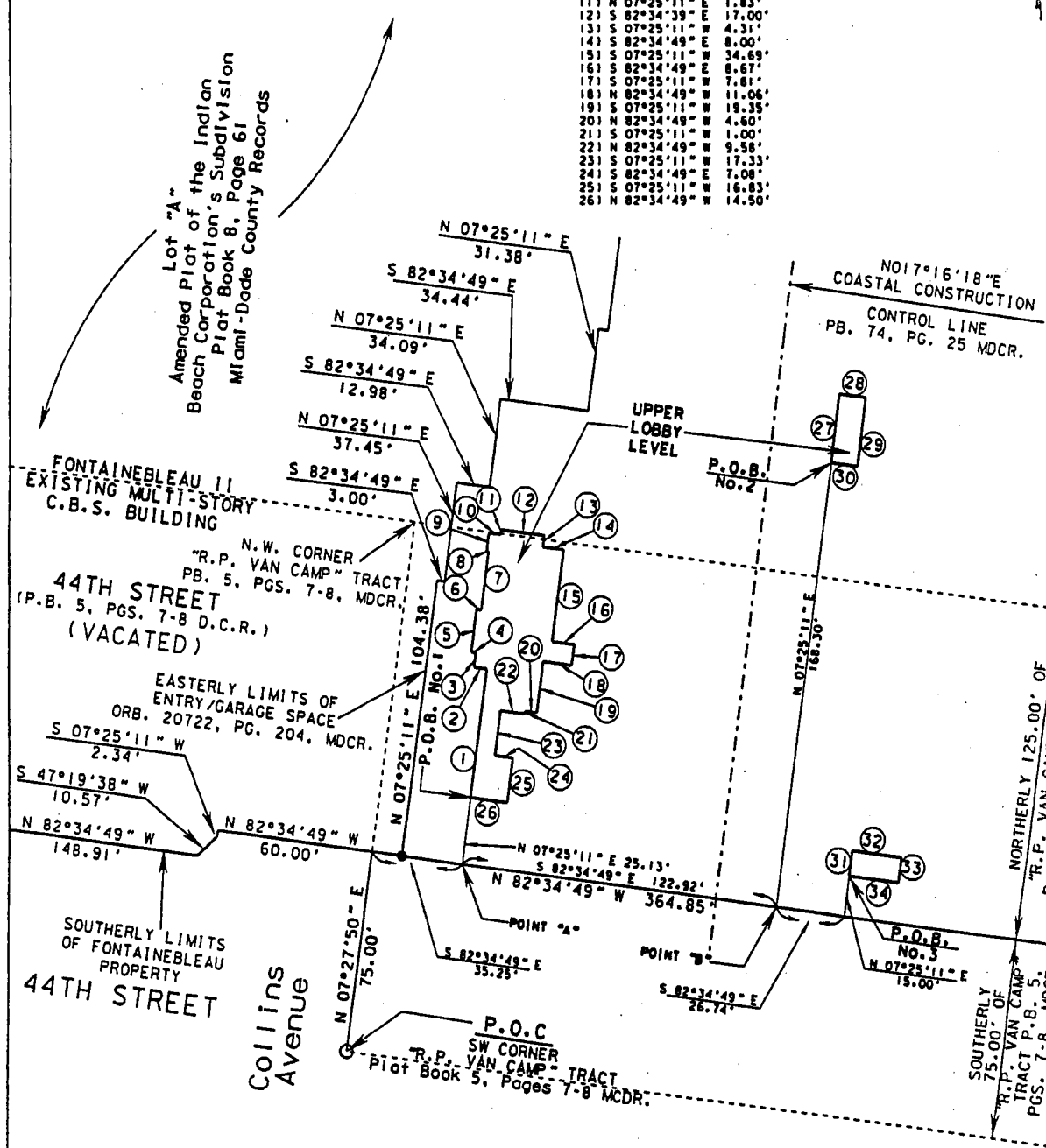

PREPARED BY TROY N. TOWNSEND DATE 02-08-05
 PROFESSIONAL SURVEYOR AND MAPPER No. LS 6425 STATE OF FLORIDA

SEE ATTACHED LEGAL DESCRIPTION SHEET 12 OF NOT VALID WITHOUT THE SIGNATURE AND THE ORIGINAL RAISED SEAL OF A FLORIDA SURVEYOR AND MAPPER.

UPDATES/REVISIONS	DATE	BY	CK'D

NOTE: The undersigned and CONSUL-TECH ENGINEERING, INC. make no representations or guarantees as to the completeness of the information reflected hereon pertaining to easements, right-of-way, set-back lines, reservations, agreements or other matters of record. This instrument is intended to reflect or set forth only those items shown in the reference above. CONSUL-TECH ENGINEERING, INC. did not research the public records for matters affecting the lands shown.

NOTE: This instrument is the property of CONSUL-TECH ENGINEERING, INC. and shall not be reproduced in whole or in part without written permission.

- SKETCH AND DESCRIPTION -

LEGAL DESCRIPTION: UPPER LOBBY LEVEL UNITS

A PORTION OF THE NORTHERLY 125.00 FEET OF THAT CERTAIN TRACT MARKED AND DESIGNATED "R.P. VAN CAMP" ON THE "AMENDED MAP OF OCEAN FRONT PROPERTY OF THE MIAMI BEACH IMPROVEMENT COMPANY", AS RECORDED IN PLAT BOOK 5, PAGES 7 AND 8, OF THE PUBLIC RECORDS OF MIAMI-DADE COUNTY, FLORIDA, AND BEING MORE PARTICULARLY DESCRIBED AS FOLLOWS:

THE VERTICALLY ENCLOSED AREA BEGINNING 27.42 FEET ABOVE ELEVATION 0.00 AS PER THE NATIONAL GEODETIC VERTICAL DATUM OF 1929 (NGVD 29) AND EXTENDING 11.33 FEET ABOVE SAID ELEVATION 27.42 FEET TO ELEVATION 38.75 FEET, WHICH SAID ELEVATIONS ARE SET ON THE COURSES SET FORTH BELOW, COMPRISING THE UPPER LOBBY LEVEL.

COMMENCE AT THE SOUTHWEST CORNER OF THE "R.P. VAN CAMP" TRACT AS PER THE "AMENDED MAP OF OCEAN FRONT PROPERTY OF THE MIAMI BEACH IMPROVEMENT COMPANY" ACCORDING TO THE PLAT THEREOF, AS RECORDED IN PLAT BOOK 5, PAGES 7 AND 8 OF THE PUBLIC RECORDS OF MIAMI-DADE COUNTY, FLORIDA; THENCE, NORTH 07°27'50" EAST ALONG THE WESTERLY LINE OF SAID "R.P. VAN CAMP" TRACT, A DISTANCE OF 75.00 FEET TO A POINT ON THE SOUTHERLY LIMITS OF THE FONTAINEBLEAU PROPERTY;

THENCE SOUTH 82°34'49" EAST, ALONG SAID SOUTHERLY LIMITS OF THE FONTAINEBLEAU PROPERTY, A DISTANCE OF 35.25 FEET TO POINT "A";

THENCE NORTH 07°25'11" EAST, A DISTANCE OF 25.13 FEET TO A POINT;

THENCE VERTICALLY FROM AN ELEVATION OF 0.00 FEET TO AN ELEVATION OF 27.42 FEET (N.G.V.D. 29), BEING A VERTICAL DISTANCE OF 27.42 FEET TO POINT OF BEGINNING ONE;

THENCE NORTH 07°25'11" EAST, A DISTANCE OF 48.92 FEET;
 THENCE NORTH 82°34'49" WEST, A DISTANCE OF 5.00 FEET;
 THENCE NORTH 07°25'11" EAST, A DISTANCE OF 5.50 FEET;
 THENCE NORTH 82°34'49" WEST, A DISTANCE OF 1.83 FEET;
 THENCE NORTH 07°25'11" EAST, A DISTANCE OF 16.00 FEET;
 THENCE SOUTH 82°34'49" EAST, A DISTANCE OF 1.83 FEET;
 THENCE NORTH 07°25'11" EAST, A DISTANCE OF 22.25 FEET;
 THENCE NORTH 82°34'49" WEST, A DISTANCE OF 0.67 FEET;
 THENCE NORTH 07°25'11" EAST, A DISTANCE OF 6.83 FEET;
 THENCE SOUTH 82°34'49" EAST, A DISTANCE OF 4.66 FEET;
 THENCE NORTH 07°25'11" EAST, A DISTANCE OF 1.83 FEET;
 THENCE SOUTH 82°34'49" EAST, A DISTANCE OF 17.00 FEET;
 THENCE SOUTH 07°25'11" WEST, A DISTANCE OF 4.31 FEET;
 THENCE SOUTH 82°34'49" EAST, A DISTANCE OF 8.00 FEET;
 THENCE SOUTH 07°25'11" WEST, A DISTANCE OF 34.69 FEET;
 THENCE SOUTH 82°34'49" EAST, A DISTANCE OF 8.67 FEET;
 THENCE SOUTH 07°25'11" WEST, A DISTANCE OF 7.81 FEET;
 THENCE NORTH 82°34'49" WEST, A DISTANCE OF 11.06 FEET;
 THENCE SOUTH 07°25'11" WEST, A DISTANCE OF 19.35 FEET;
 THENCE NORTH 82°34'49" WEST, A DISTANCE OF 4.60 FEET;
 THENCE SOUTH 07°25'11" WEST, A DISTANCE OF 1.00 FEET;
 THENCE NORTH 82°34'49" WEST, A DISTANCE OF 9.58 FEET;
 THENCE SOUTH 07°25'11" WEST, A DISTANCE OF 17.33 FEET;
 THENCE SOUTH 82°34'49" EAST, A DISTANCE OF 7.08 FEET;
 THENCE SOUTH 07°25'11" WEST, A DISTANCE OF 16.83 FEET;
 THENCE NORTH 82°34'49" WEST, A DISTANCE OF 14.50 FEET TO POINT OF BEGINNING ONE.

SEE ATTACHED SKETCH OF DESCRIPTION
SHEET 13 OF 2

PREPARED BY _____ DATE 02-08-05
 TROY N. TOWNSEND
 PROFESSIONAL SURVEYOR AND MAPPER No. LS 6425
 STATE OF FLORIDA

NOT VALID WITHOUT THE SIGNATURE
 AND THE ORIGINAL RAISED SEAL OF
 A FLORIDA SURVEYOR AND MAPPER.

UPDATES / REVISIONS	DATE	BY	CK'D

NOTE: The undersigned and CONSUL-TECH ENGINEERING, INC. make no representations or guarantees as to the completeness of the information reflected hereon pertaining to easements, right-of-way, set-back lines, reservations, agreements or other matters of record. This instrument is intended to reflect or set forth only those items shown in the reference above. CONSUL-TECH ENGINEERING, INC. did not research the public records for matters affecting the lands shown.
 NOTE: This instrument is the property of CONSUL-TECH ENGINEERING, INC. and shall not be reproduced in whole or in part without written permission of the undersigned.

- SKETCH AND DESCRIPTION -

TOGETHER WITH:

A PORTION OF THE NORTHERLY 125.00 FEET OF THAT CERTAIN TRACT MARKED AND DESIGNATED "R.P. VAN CAMP" ON THE "AMENDED MAP OF OCEAN FRONT PROPERTY OF THE MIAMI BEACH IMPROVEMENT COMPANY", AS RECORDED IN PLAT BOOK 5, PAGES 7 AND 8, OF THE PUBLIC RECORDS OF MIAMI-DADE COUNTY, FLORIDA, AND BEING MORE PARTICULARLY DESCRIBED AS FOLLOWS:

THE VERTICALLY ENCLOSED AREA BEGINNING 27.42 FEET ABOVE ELEVATION 0.00 AS PER THE NATIONAL GEODETIC VERTICAL DATUM OF 1929 (NGVD 29) AND EXTENDING 11.33 FEET ABOVE SAID ELEVATION 27.42 FEET TO ELEVATION 38.75 FEET, WHICH SAID ELEVATIONS ARE SET ON THE COURSES SET FORTH BELOW, COMPRISING THE UPPER LOBBY LEVEL.

COMMENCE AT SAID POINT "A";
THENCE SOUTH 82°34'49" EAST, ALONG SAID SOUTHERLY LIMITS OF THE FONTAINEBLEAU PROPERTY, A DISTANCE OF 122.92 FEET TO POINT "B";
THENCE NORTH 07°25'11" EAST, A DISTANCE OF 168.30 FEET TO A POINT;
THENCE VERTICALLY FROM AN ELEVATION OF 0.00 FEET TO AN ELEVATION OF 27.42 FEET (N.G.V.D. 29), BEING A VERTICAL DISTANCE OF 27.42 FEET TO POINT OF BEGINNING TWO;

THENCE NORTH 07°25'11" EAST, A DISTANCE OF 26.67 FEET;
THENCE SOUTH 82°34'49" EAST, A DISTANCE OF 10.33 FEET;
THENCE SOUTH 07°25'11" WEST, A DISTANCE OF 26.67 FEET;
THENCE NORTH 82°34'49" WEST, A DISTANCE OF 10.33 FEET TO POINT OF BEGINNING TWO.

AND:

A PORTION OF THE NORTHERLY 125.00 FEET OF THAT CERTAIN TRACT MARKED AND DESIGNATED "R.P. VAN CAMP" ON THE "AMENDED MAP OF OCEAN FRONT PROPERTY OF THE MIAMI BEACH IMPROVEMENT COMPANY", AS RECORDED IN PLAT BOOK 5, PAGES 7 AND 8, OF THE PUBLIC RECORDS OF MIAMI-DADE COUNTY, FLORIDA, AND BEING MORE PARTICULARLY DESCRIBED AS FOLLOWS:

THE VERTICALLY ENCLOSED AREA BEGINNING 27.42 FEET ABOVE ELEVATION 0.00 AS PER THE NATIONAL GEODETIC VERTICAL DATUM OF 1929 (NGVD 29) AND EXTENDING 11.33 FEET ABOVE SAID ELEVATION 27.42 FEET TO ELEVATION 38.75 FEET, WHICH SAID ELEVATIONS ARE SET ON THE COURSES SET FORTH BELOW, COMPRISING THE UPPER LOBBY LEVEL.

COMMENCE AT SAID POINT "B";
THENCE SOUTH 82°34'49" EAST, ALONG SAID SOUTHERLY LIMITS OF THE FONTAINEBLEAU PROPERTY, A DISTANCE OF 26.74 FEET;
THENCE NORTH 07°25'11" EAST, A DISTANCE OF 15.00 FEET TO A POINT;
THENCE VERTICALLY FROM AN ELEVATION OF 0.00 FEET TO AN ELEVATION OF 27.42 FEET (N.G.V.D. 29), BEING A VERTICAL DISTANCE OF 27.42 FEET TO POINT OF BEGINNING THREE;

THENCE NORTH 07°25'11" EAST, A DISTANCE OF 9.67 FEET;
THENCE SOUTH 82°34'49" EAST, A DISTANCE OF 19.33 FEET;
THENCE SOUTH 07°25'11" WEST, A DISTANCE OF 9.67 FEET;
THENCE NORTH 82°34'49" WEST, A DISTANCE OF 19.33 FEET TO POINT OF BEGINNING THREE.

SAID LANDS SITUATE, LYING AND BEING IN THE CITY OF MIAMI BEACH, MIAMI-DADE COUNTY, FLORIDA, AND CONTAINING 2715 SQUARE FEET, MORE OR LESS.

GENERAL NOTES:

- BEARINGS AS SHOWN HEREON ARE BASED ON THE COASTAL CONSTRUCTION CONTROL LINE AND THE EROSION CONTROL LINE, AS RECORDED IN PLAT BOOK 74, PAGE 25, OF THE PUBLIC RECORDS OF MIAMI-DADE COUNTY FLORIDA, AND BEARING N 07°16'18" E.
- NO FIELD WORK HAS BEEN PERFORMED DURING THE CREATION OF THIS SKETCH.
- THIS SKETCH HAS BEEN PRODUCED FOR TURNBERRY ASSOCIATES, INCORPORATED.

SEE ATTACHED SKETCH OF DESCRIPTION SHEET 14 OF 21

PREPARED BY
TROY N. TOWNSEND DATE 02-08-05
PROFESSIONAL SURVEYOR AND MAPPER No. LS 6425
STATE OF FLORIDA

NOT VALID WITHOUT THE SIGNATURE AND THE ORIGINAL RAISED SEAL OF A FLORIDA SURVEYOR AND MAPPER.

UPDATES/REVISIONS	DATE	BY	CK'D

NOTE: The undersigned and CONSUL-TECH ENGINEERING, INC. make no representations or guarantees as to the completeness of the information reflected hereon pertaining to easements, right-of-way, set-back lines, reservations, agreements or other matters of record. This instrument is intended to reflect or set forth only those items shown in the references above. CONSUL-TECH ENGINEERING, INC. did not research the public records for matters affecting the lands shown.
NOTE: This instrument is the property of CONSUL-TECH ENGINEERING, INC. and shall not be reproduced in whole or in part without written permission.

L.B. NO. 7121

LEGEND:

- PG. : PAGE
- P.B. : PLAT BOOK
- P.O.B. : POINT OF BEGINNING
- P.O.C. : POINT OF COMMENCEMENT
- MDCR. : MIAMI-DADE COUNTY RECORDS
- O.R.B. : OFFICIAL RECORD BOOK
- N.G.V.D. : NATIONAL GEODETIC VERTICAL DATUM
- D.C.R. : DADE COUNTY RECORDS

- SKETCH AND DESCRIPTION -

TOWER III - THIRD AND FOURTH LEVEL UNITS

11	N 07°25'11" E	6.83'	291	S 07°25'11" W	185.00'
21	S 82°34'49" E	0.67'	301	N 82°34'49" W	52.00'
31	N 07°25'11" E	1.17'	311	N 07°25'11" E	2.65'
41	N 82°34'49" W	5.00'	321	N 82°34'49" W	5.66'
51	N 07°25'11" E	57.25'	331	N 07°25'11" E	6.66'
61	N 82°34'49" W	1.83'	341	S 82°34'49" E	7.31'
71	N 07°25'11" E	16.00'	351	N 07°25'11" E	106.50'
81	S 82°34'49" E	1.83'	361	N 82°34'49" W	102.75'
91	N 07°25'11" E	22.25'	371	S 07°25'11" W	24.00'
101	N 82°34'49" W	0.67'	381	N 82°34'49" W	3.88'
111	N 07°25'11" E	6.83'	391	S 07°25'11" W	7.83'
121	S 82°34'39" E	4.67'	401	S 82°34'49" E	3.05'
131	N 07°25'11" E	1.83'	411	S 07°25'11" W	10.00'
141	S 82°34'49" E	1.01'	421	N 82°34'49" W	15.08'
151	N 07°25'11" E	15.67'	431	N 07°25'11" E	0.50'
161	N 82°34'49" W	1.00'	441	N 82°34'49" W	7.67'
171	N 07°25'11" E	14.69'	451	S 07°25'11" W	2.33'
181	S 82°34'49" E	0.58'	461	N 82°34'49" W	3.08'
191	N 07°25'11" E	26.83'	471	S 07°25'11" W	28.17'
201	S 82°34'49" E	43.60'	481	N 82°34'49" W	14.50'
211	N 07°25'11" E	13.67'	491	S 07°25'11" W	28.50'
221	S 82°34'49" E	21.06'	501	S 82°34'49" E	3.25'
231	S 07°25'11" W	7.00'	511	S 07°25'11" W	5.67'
241	S 82°34'49" E	58.67'	521	S 82°34'49" E	10.67'
251	N 07°25'11" E	4.67'	531	S 07°25'11" W	10.50'
261	S 82°34'49" E	9.33'	541	N 82°34'49" W	16.92'
271	N 07°25'11" E	5.33'	551	S 07°25'11" W	0.33'
281	S 82°34'49" E	69.42'	561	N 82°34'49" W	5.08'

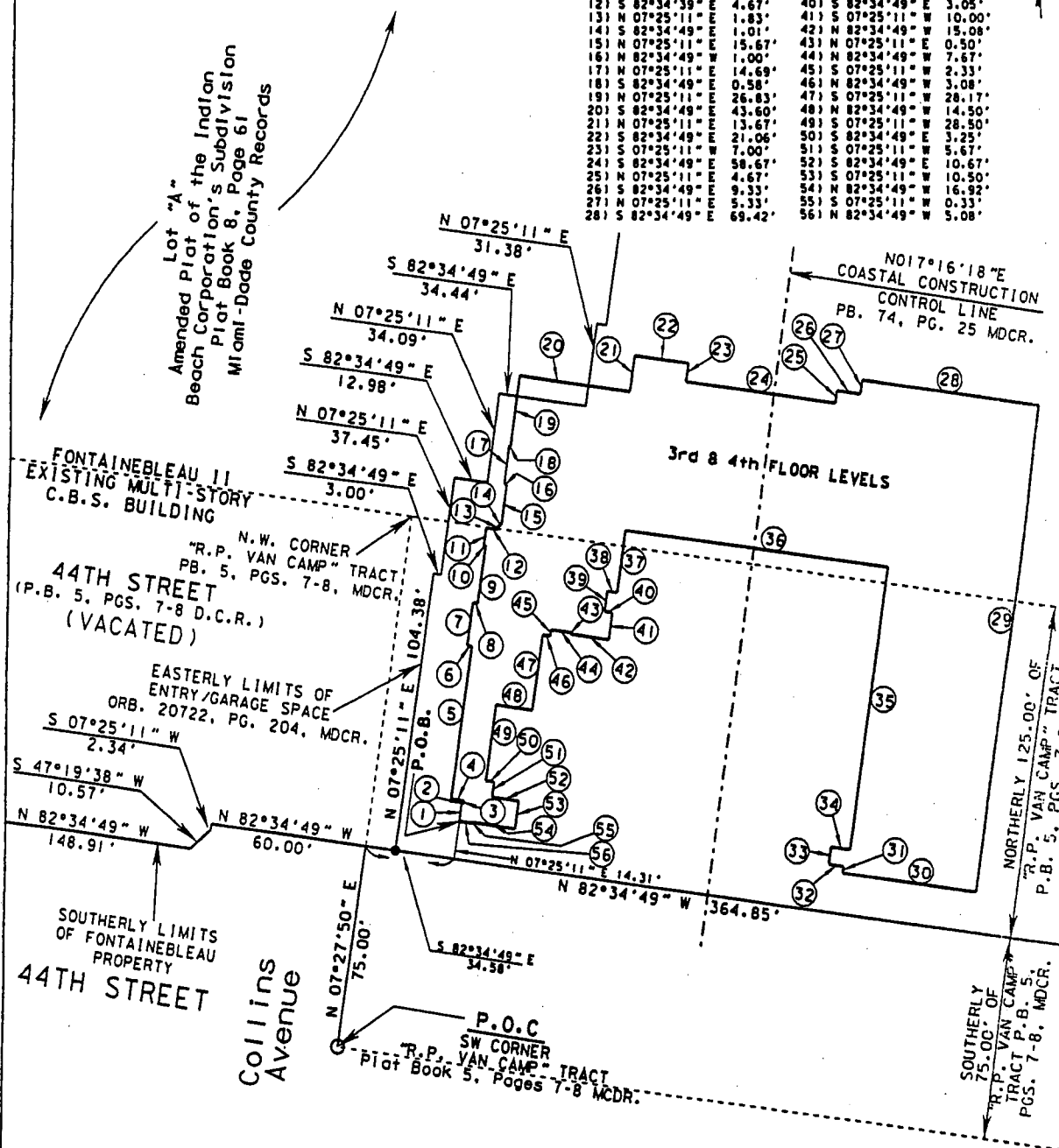

PREPARED BY TROY N. TOWNSEND DATE 02-08-05
 PROFESSIONAL SURVEYOR AND MAPPER No. LS 6425
 STATE OF FLORIDA

SEE ATTACHED LEGAL DESCRIPTION SHEET 15 OF 2.
 NOT VALID WITHOUT THE SIGNATURE AND THE ORIGINAL RAISED SEAL OF A FLORIDA SURVEYOR AND MAPPER.

UPDATES / REVISIONS	DATE	BY	CK'D

NOTE: The undersigned and CONSUL-TECH ENGINEERING, INC. make no representations or guarantees as to the completeness of the information reflected hereon pertaining to easements, right-of-way, set-back lines, reservations, agreements or other matters of record. This instrument is intended to reflect or set forth only those items shown in the references above. CONSUL-TECH ENGINEERING, INC. did not research the public records for matters affecting the lands shown.
 NOTE: This instrument is the property of CONSUL-TECH ENGINEERING, INC.

- SKETCH AND DESCRIPTION -

LEGAL DESCRIPTION: THIRD AND FOURTH LEVEL UNITS

A PORTION OF THE NORTHERLY 125.00 FEET OF THAT CERTAIN TRACT MARKED AND DESIGNATED "R.P. VAN CAMP" ON THE "AMENDED MAP OF OCEAN FRONT PROPERTY OF THE MIAMI BEACH IMPROVEMENT COMPANY", AS RECORDED IN PLAT BOOK 5, PAGES 7 AND 8, OF THE PUBLIC RECORDS OF MIAMI-DADE COUNTY, FLORIDA, AND BEING MORE PARTICULARLY DESCRIBED AS FOLLOWS:

THE VERTICALLY ENCLOSED AREA BEGINNING 38.75 FEET ABOVE ELEVATION 0.00 AS PER THE NATIONAL GEODETIC VERTICAL DATUM OF 1929 (NGVD 29) AND EXTENDING 19.17 FEET ABOVE SAID ELEVATION 38.75 FEET TO ELEVATION 57.92 FEET, WHICH SAID ELEVATIONS ARE SET ON THE COURSES SET FORTH BELOW, COMPRISING THE THIRD AND FOURTH LEVELS.

COMMENCE AT THE SOUTHWEST CORNER OF THE "R.P. VAN CAMP" TRACT AS PER THE "AMENDED MAP OF OCEAN FRONT PROPERTY OF THE MIAMI BEACH IMPROVEMENT COMPANY" ACCORDING TO THE PLAT THEREOF, AS RECORDED IN PLAT BOOK 5, PAGES 7 AND 8 OF THE PUBLIC RECORDS OF MIAMI-DADE COUNTY, FLORIDA; THENCE NORTH 07°27'50" EAST ALONG THE WESTERLY LINE OF SAID "R.P. VAN CAMP" TRACT, A DISTANCE OF 75.00 FEET TO A POINT ON THE SOUTHERLY LIMITS OF THE FONTAINEBLEAU PROPERTY;
THENCE SOUTH 82°34'49" EAST, ALONG SAID SOUTHERLY LIMITS OF THE FONTAINEBLEAU PROPERTY, A DISTANCE OF 34.58 FEET;
THENCE NORTH 07°25'11" EAST, A DISTANCE OF 14.31 FEET TO A POINT;
THENCE VERTICALLY FROM AN ELEVATION OF 0.00 FEET TO AN ELEVATION OF 38.75 FEET (N.G.V.D. 29), BEING A VERTICAL DISTANCE OF 38.75 FEET TO THE POINT OF BEGINNING;

THENCE NORTH 07°25'11" EAST, A DISTANCE OF 6.83 FEET;
THENCE SOUTH 82°34'49" EAST, A DISTANCE OF 0.67 FEET;
THENCE NORTH 07°25'11" EAST, A DISTANCE OF 1.17 FEET;
THENCE NORTH 82°34'49" WEST, A DISTANCE OF 5.00 FEET;
THENCE NORTH 07°25'11" EAST, A DISTANCE OF 57.25 FEET;
THENCE NORTH 82°34'49" WEST, A DISTANCE OF 1.83 FEET;
THENCE NORTH 07°25'11" EAST, A DISTANCE OF 16.00 FEET;
THENCE SOUTH 82°34'49" EAST, A DISTANCE OF 1.83 FEET;
THENCE NORTH 07°25'11" EAST, A DISTANCE OF 22.25 FEET;
THENCE NORTH 82°34'49" WEST, A DISTANCE OF 0.67 FEET;
THENCE NORTH 07°25'11" EAST, A DISTANCE OF 6.83 FEET;
THENCE SOUTH 82°34'49" EAST, A DISTANCE OF 4.67 FEET;
THENCE NORTH 07°25'11" EAST, A DISTANCE OF 1.83 FEET;
THENCE SOUTH 82°34'49" EAST, A DISTANCE OF 1.01 FEET;
THENCE NORTH 07°25'11" EAST, A DISTANCE OF 15.67 FEET;
THENCE NORTH 82°34'49" WEST, A DISTANCE OF 1.00 FEET;
THENCE NORTH 07°25'11" EAST, A DISTANCE OF 14.69 FEET;
THENCE SOUTH 82°34'49" EAST, A DISTANCE OF 0.58 FEET;
THENCE NORTH 07°25'11" EAST, A DISTANCE OF 26.83 FEET;
THENCE SOUTH 82°34'49" EAST, A DISTANCE OF 43.60 FEET;
THENCE NORTH 07°25'11" EAST, A DISTANCE OF 13.67 FEET;
THENCE SOUTH 82°34'49" EAST, A DISTANCE OF 21.06 FEET;
THENCE SOUTH 07°25'11" WEST, A DISTANCE OF 7.00 FEET;
THENCE SOUTH 82°34'49" EAST, A DISTANCE OF 58.67 FEET;
THENCE NORTH 07°25'11" EAST, A DISTANCE OF 4.67 FEET;
THENCE SOUTH 82°34'49" EAST, A DISTANCE OF 9.33 FEET;

SEE ATTACHED SKETCH OF DESCRIPTION SHEET 16 OF

PREPARED BY
TROY N. TOWNSEND DATE 02-08-05
PROFESSIONAL SURVEYOR AND MAPPER No. LS 6425
STATE OF FLORIDA

NOT VALID WITHOUT THE SIGNATURE AND THE ORIGINAL RAISED SEAL OF A FLORIDA SURVEYOR AND MAPPER

UPDATES/REVISIONS	DATE	BY	CK'D

NOTE: The undersigned and CONSUL-TECH ENGINEERING, INC. make no representations or guarantees as to the completeness of the information reflected hereon pertaining to easements, right-of-way, set-back lines, reservations, agreements or other matters of record. This instrument is intended to reflect or set forth only those items shown in the reference above. CONSUL-TECH ENGINEERING, INC. did not research the public records for matters affecting the lands shown.
NOTE: This instrument is the property of CONSUL-TECH ENGINEERING, INC. and shall not be reproduced in whole or in part without written permission.

- SKETCH AND DESCRIPTION -

LEGAL DESCRIPTION: THIRD AND FOURTH LEVEL UNITS (CONTINUED)

THENCE NORTH 07°25'11" EAST, A DISTANCE OF 5.33 FEET;
 THENCE SOUTH 82°34'49" EAST, A DISTANCE OF 69.42 FEET;
 THENCE SOUTH 07°25'11" WEST, A DISTANCE OF 185.00 FEET;
 THENCE NORTH 82°34'49" WEST, A DISTANCE OF 52.00 FEET;
 THENCE NORTH 07°25'11" EAST, A DISTANCE OF 2.65 FEET;
 THENCE NORTH 82°34'49" WEST, A DISTANCE OF 5.66 FEET;
 THENCE NORTH 07°25'11" EAST, A DISTANCE OF 6.66 FEET;
 THENCE SOUTH 82°34'49" EAST, A DISTANCE OF 7.31 FEET;
 THENCE NORTH 07°25'11" EAST, A DISTANCE OF 106.50 FEET;
 THENCE NORTH 82°34'49" WEST, A DISTANCE OF 102.75 FEET;
 THENCE SOUTH 07°25'11" WEST, A DISTANCE OF 24.00 FEET;
 THENCE NORTH 82°34'49" WEST, A DISTANCE OF 3.88 FEET;
 THENCE SOUTH 07°25'11" WEST, A DISTANCE OF 7.83 FEET;
 THENCE SOUTH 82°34'49" EAST, A DISTANCE OF 3.05 FEET;
 THENCE SOUTH 07°25'11" WEST, A DISTANCE OF 10.00 FEET;
 THENCE NORTH 82°34'49" WEST, A DISTANCE OF 15.08 FEET;
 THENCE NORTH 07°25'11" EAST, A DISTANCE OF 0.50 FEET;
 THENCE NORTH 82°34'49" WEST, A DISTANCE OF 7.67 FEET;
 THENCE SOUTH 07°25'11" WEST, A DISTANCE OF 2.33 FEET;
 THENCE NORTH 82°34'49" WEST, A DISTANCE OF 3.08 FEET;
 THENCE SOUTH 07°25'11" WEST, A DISTANCE OF 28.17 FEET;
 THENCE NORTH 82°34'49" WEST, A DISTANCE OF 14.50 FEET;
 THENCE SOUTH 07°25'11" WEST, A DISTANCE OF 28.50 FEET;
 THENCE SOUTH 82°34'49" EAST, A DISTANCE OF 3.25 FEET;
 THENCE SOUTH 07°25'11" WEST, A DISTANCE OF 5.67 FEET;
 THENCE SOUTH 82°34'49" EAST, A DISTANCE OF 10.67 FEET;
 THENCE SOUTH 07°25'11" WEST, A DISTANCE OF 10.50 FEET;
 THENCE NORTH 82°34'49" WEST, A DISTANCE OF 16.92 FEET;
 THENCE SOUTH 07°25'11" WEST, A DISTANCE OF 0.33 FEET;
 THENCE NORTH 82°34'49" WEST, A DISTANCE OF 5.08 FEET TO THE POINT OF BEGINNING.

SAID LANDS SITUATE, LYING AND BEING IN THE CITY OF MIAMI BEACH, MIAMI-DADE COUNTY, FLORIDA, AND CONTAINING 22,145 SQUARE FEET, MORE OR LESS.

GENERAL NOTES:

1. BEARINGS AS SHOWN HEREON ARE BASED ON THE COASTAL CONSTRUCTION CONTROL LINE AND THE EROSION CONTROL LINE, AS RECORDED IN PLAT BOOK 74, PAGE 25, OF THE PUBLIC RECORDS OF MIAMI-DADE COUNTY FLORIDA, AND BEARING N 07°16'18" E.
2. NO FIELD WORK HAS BEEN PERFORMED DURING THE CREATION OF THIS SKETCH.
3. THIS SKETCH HAS BEEN PRODUCED FOR TURNBERRY ASSOCIATES, INCORPORATED.

SEE ATTACHED SKETCH OF DESCRIPTION SHEET 17 OF 2

PREPARED BY _____ DATE 02-08-05
 TROY N. TOWNSEND PROFESSIONAL SURVEYOR AND MAPPER No. LS 6425
 STATE OF FLORIDA

NOT VALID WITHOUT THE SIGNATURE
 AND THE ORIGINAL RAISED SEAL OF
 A FLORIDA SURVEYOR AND MAPPER.

UPDATES/REVISIONS	DATE	BY	CK'D

NOTE: The undersigned and CONSUL-TECH ENGINEERING, INC. make no representations or guarantees as to the completeness of the information reflected hereon pertaining to easements, right-of-way, set-back lines, reservations, agreements or other matters of record. This instrument is intended to reflect or set forth only those items shown in the reference above. CONSUL-TECH ENGINEERING, INC. did not research the public records for matters affecting the lands shown.
 NOTE: This instrument is the property of CONSUL-TECH ENGINEERING, INC. and shall not be reproduced in whole or in part without written permission.

L.B. NO. 7121

LEGEND:

- PG. : PAGE
- P.B. : PLAT BOOK
- P.O.B. : POINT OF BEGINNING
- P.O.C. : POINT OF COMMENCEMENT
- MDCR. : MIAMI-DADE COUNTY RECORDS
- O.R.B. : OFFICIAL RECORD BOOK
- N.G.V.D. : NATIONAL GEODETIC VERTICAL DATUM
- D.C.R. : DADE COUNTY RECORDS

- SKETCH AND DESCRIPTION -

TOWER III - FIFTH THROUGH ROOF LEVEL UNITS

- 11 N 07°25'11" E 6.83'
- 21 S 82°34'49" E 0.67'
- 31 N 07°25'11" E 1.17'
- 41 N 82°34'49" W 5.00'
- 51 N 07°25'11" E 57.25'
- 61 N 82°34'49" W 1.83'
- 71 N 07°25'11" E 16.00'
- 81 S 82°34'49" E 1.83'
- 91 N 07°25'11" E 22.25'
- 101 N 82°34'49" W 0.67'
- 111 N 07°25'11" E 6.83'
- 121 S 82°34'49" E 4.67'
- 131 N 07°25'11" E 1.83'
- 141 S 82°34'49" E 1.01'
- 151 N 07°25'11" E 15.67'
- 161 N 82°34'49" W 1.00'
- 171 N 07°25'11" E 14.69'
- 181 S 82°34'49" E 0.58'
- 191 N 07°25'11" E 26.83'
- 201 S 82°34'49" E 123.33'
- 211 N 07°25'11" E 11.66'
- 221 S 82°34'49" E 9.33'
- 231 N 07°25'11" E 5.33'
- 241 S 82°34'49" E 69.42'
- 251 N 07°25'11" W 185.68'
- 261 N 82°34'49" W 179.51'
- 271 S 07°25'11" W 0.33'
- 281 N 82°34'49" W 17.75'
- 291 S 07°25'11" W 0.33'
- 301 N 82°34'49" W 9.08'

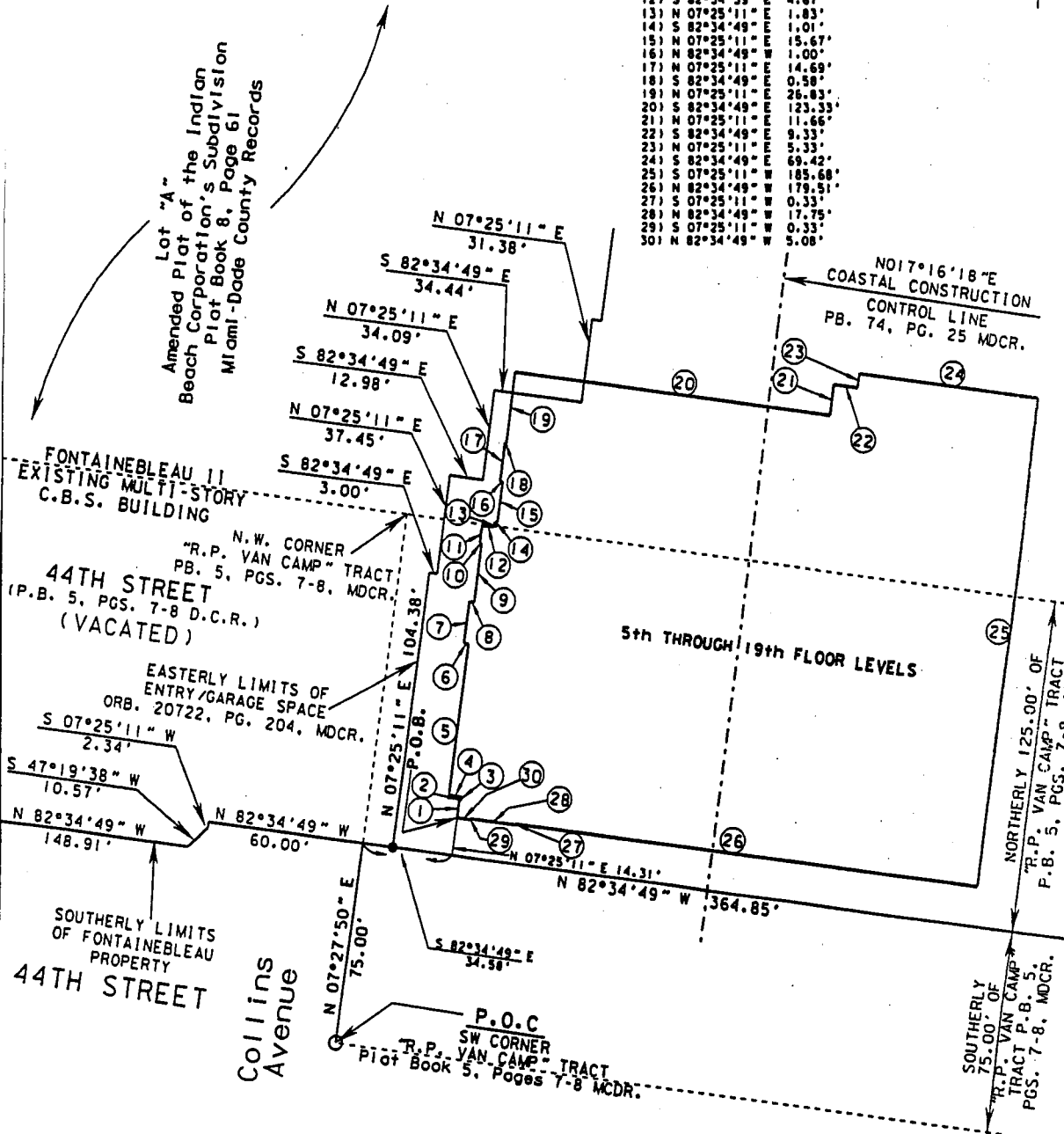

PREPARED BY TROY N. TOWNSEND
 PROFESSIONAL SURVEYOR AND MAPPER No. LS 6425
 STATE OF FLORIDA

DATE 02-08-05

SEE ATTACHED LEGAL DESCRIPTION SHEET 18 OF 2

NOT VALID WITHOUT THE SIGNATURE AND THE ORIGINAL RAISED SEAL OF A FLORIDA SURVEYOR AND MAPPER.

UPDATES/REVISIONS	DATE	BY	CK'D

NOTE: The undersigned and CONSUL-TECH ENGINEERING, INC. make no representations or guarantees as to the completeness of the information reflected hereon pertaining to easements, right-of-way, set-back lines, reservations, agreements or other matters of record. This instrument is intended to reflect or set forth only those items shown in the references above. CONSUL-TECH ENGINEERING, INC. did not research the public records for matters affecting the lands shown.

NOTE: This instrument is the property of CONSUL-TECH ENGINEERING, INC. and shall not be reproduced in whole or in part without written permission.

- SKETCH AND DESCRIPTION -

LEGAL DESCRIPTION: FIFTH THROUGH ROOF LEVEL UNITS

A PORTION OF THE NORTHERLY 125.00 FEET OF THAT CERTAIN TRACT MARKED AND DESIGNATED "R.P. VAN CAMP" ON THE "AMENDED MAP OF OCEAN FRONT PROPERTY OF THE MIAMI BEACH IMPROVEMENT COMPANY", AS RECORDED IN PLAT BOOK 5, PAGES 7 AND 8, OF THE PUBLIC RECORDS OF MIAMI-DADE COUNTY, FLORIDA, AND BEING MORE PARTICULARLY DESCRIBED AS FOLLOWS:

THE VERTICALLY ENCLOSED AREA BEGINNING 57.92 FEET ABOVE ELEVATION 0.00 AS PER THE NATIONAL GEODETIC VERTICAL DATUM OF 1929 (NGVD 29) AND EXTENDING 172.00 FEET ABOVE SAID ELEVATION 57.92 FEET TO ELEVATION 230.00 FEET, WHICH SAID ELEVATIONS ARE SET ON THE COURSES SET FORTH BELOW, COMPRISING THE FIFTH THROUGH ROOF LEVELS.

COMMENCE AT THE SOUTHWEST CORNER OF THE "R.P. VAN CAMP" TRACT AS PER THE "AMENDED MAP OF OCEAN FRONT PROPERTY OF THE MIAMI BEACH IMPROVEMENT COMPANY" ACCORDING TO THE PLAT THEREOF, AS RECORDED IN PLAT BOOK 5, PAGES 7 AND 8 OF THE PUBLIC RECORDS OF MIAMI-DADE COUNTY, FLORIDA; THENCE; NORTH 07°27'50" EAST ALONG THE WESTERLY LINE OF SAID "R.P. VAN CAMP" TRACT, A DISTANCE OF 75.00 FEET TO A POINT ON THE SOUTHERLY LIMITS OF THE FONTAINEBLEAU PROPERTY;
THENCE SOUTH 82°34'49" EAST, ALONG SAID SOUTHERLY LIMITS OF THE FONTAINEBLEAU PROPERTY, A DISTANCE OF 34.58 FEET;
THENCE NORTH 07°25'11" EAST, A DISTANCE OF 14.31 FEET TO A POINT;
THENCE VERTICALLY FROM AN ELEVATION OF 0.00 FEET TO AN ELEVATION OF 57.92 FEET (N.G.V.D. 29), BEING A VERTICAL DISTANCE OF 57.92 FEET TO THE POINT OF BEGINNING;

THENCE NORTH 07°25'11" EAST, A DISTANCE OF 6.83 FEET;
THENCE SOUTH 82°34'49" EAST, A DISTANCE OF 0.67 FEET;
THENCE NORTH 07°25'11" EAST, A DISTANCE OF 1.17 FEET;
THENCE NORTH 82°34'49" WEST, A DISTANCE OF 5.00 FEET;
THENCE NORTH 07°25'11" EAST, A DISTANCE OF 57.25 FEET;
THENCE NORTH 82°34'49" WEST, A DISTANCE OF 1.83 FEET;
THENCE NORTH 07°25'11" EAST, A DISTANCE OF 16.00 FEET;
THENCE SOUTH 82°34'49" EAST, A DISTANCE OF 1.83 FEET;
THENCE NORTH 07°25'11" EAST, A DISTANCE OF 22.25 FEET;
THENCE NORTH 82°34'49" WEST, A DISTANCE OF 0.67 FEET;
THENCE NORTH 07°25'11" EAST, A DISTANCE OF 6.83 FEET;
THENCE SOUTH 82°34'49" EAST, A DISTANCE OF 4.67 FEET;
THENCE NORTH 07°25'11" EAST, A DISTANCE OF 1.83 FEET;
THENCE SOUTH 82°34'49" EAST, A DISTANCE OF 1.01 FEET;
THENCE NORTH 07°25'11" EAST, A DISTANCE OF 15.67 FEET;
THENCE NORTH 82°34'49" WEST, A DISTANCE OF 1.00 FEET;
THENCE NORTH 07°25'11" EAST, A DISTANCE OF 14.69 FEET;
THENCE SOUTH 82°34'49" EAST, A DISTANCE OF 0.58 FEET;
THENCE NORTH 07°25'11" EAST, A DISTANCE OF 26.83 FEET;
THENCE SOUTH 82°34'49" EAST, A DISTANCE OF 123.33 FEET;
THENCE NORTH 07°25'11" EAST, A DISTANCE OF 11.66 FEET;
THENCE SOUTH 82°34'49" EAST, A DISTANCE OF 9.33 FEET;
THENCE NORTH 07°25'11" EAST, A DISTANCE OF 5.33 FEET;
THENCE SOUTH 82°34'49" EAST, A DISTANCE OF 69.42 FEET;
THENCE SOUTH 07°25'11" WEST, A DISTANCE OF 185.68 FEET;
THENCE NORTH 82°34'49" WEST, A DISTANCE OF 179.51 FEET;
THENCE SOUTH 07°25'11" WEST, A DISTANCE OF 0.33 FEET;
THENCE NORTH 82°34'49" WEST, A DISTANCE OF 17.75 FEET;
THENCE SOUTH 07°25'11" WEST, A DISTANCE OF 0.33 FEET;
THENCE NORTH 82°34'49" WEST, A DISTANCE OF 5.08 FEET TO THE POINT OF BEGINNING.

SAID LANDS SITUATE, LYING AND BEING IN THE CITY OF MIAMI BEACH, MIAMI-DADE COUNTY, FLORIDA, AND CONTAINING 35,894 SQUARE FEET, MORE OR LESS.

SEE ATTACHED SKETCH OF DESCRIPTION
SHEET 19 OF 22

PREPARED BY
TROY N. TOWNSEND DATE 02-08-05
PROFESSIONAL SURVEYOR AND MAPPER No. LS 6425
STATE OF FLORIDA

NOT VALID WITHOUT THE SIGNATURE
AND THE ORIGINAL RAISED SEAL OF
A FLORIDA SURVEYOR AND MAPPER.

UPDATES/REVISIONS	DATE	BY	CK'D	NOTE
				NOTE: The undersigned and CONSUL-TECH ENGINEERING, INC. make no representations or guarantees as to the completeness of the information reflected hereon pertaining to easements, right-of-way, set-back lines, reservations, agreements or other matters of record. This instrument is intended to reflect or set forth only those items shown in the references above. CONSUL-TECH ENGINEERING, INC. did not research the public records for matters affecting the lands shown. NOTE: This instrument is the property of CONSUL-TECH ENGINEERING, INC. and shall not be reproduced in whole or in part without written permission of CONSUL-TECH ENGINEERING, INC. ©

L.B. NO. 7121

LEGEND:

- PG. = PAGE
- P.B. = PLAT BOOK
- P.O.B. = POINT OF BEGINNING
- P.O.C. = POINT OF COMMENCEMENT
- MDCR. = MIAMI-DADE COUNTY RECORDS
- O.R.B. = OFFICIAL RECORD BOOK
- N.G.V.D. = NATIONAL GEODETIC VERTICAL DATUM
- D.C.R. = DADE COUNTY RECORDS

- SKETCH AND DESCRIPTION -

TOWER III - POOLS AND SPA

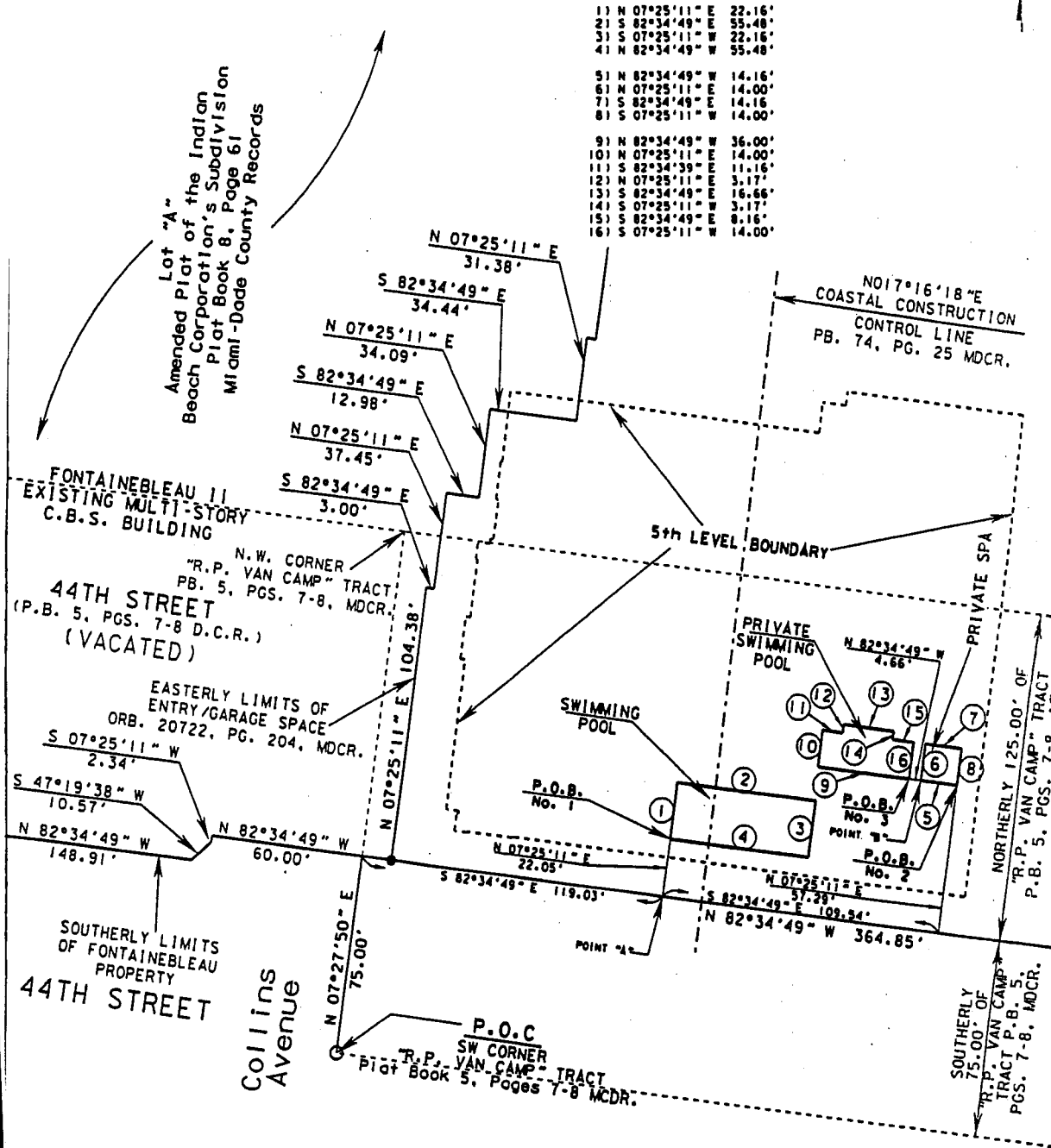

PREPARED BY TROY N. TOWNSEND
 PROFESSIONAL SURVEYOR AND MAPPER No. LS 6425
 STATE OF FLORIDA
 DATE 02-08-05

SEE ATTACHED LEGAL DESCRIPTION SHEET 20 OF 2
 NOT VALID WITHOUT THE SIGNATURE AND THE ORIGINAL RAISED SEAL OF A FLORIDA SURVEYOR AND MAPPER.

UPDATES/REVISIONS	DATE	BY	CK'D

NOTE: The undersigned and CONSUL-TECH ENGINEERING, INC. make no representations or guarantees as to the completeness of the information reflected hereon pertaining to easements, right-of-way, set-back lines, reservations, agreements or other matters of record. This instrument is intended to reflect or set forth only those items shown in the reference above. CONSUL-TECH ENGINEERING, INC. did not research the public records for matters affecting the lands shown.
 NOTE: This instrument is the property of CONSUL-TECH ENGINEERING, INC. and shall not be reproduced in whole or in part without written permission.

- SKETCH AND DESCRIPTION -

LEGAL DESCRIPTION: SWIMMING POOL

A PORTION OF THE NORTHERLY 125.00 FEET OF THAT CERTAIN TRACT MARKED AND DESIGNATED "R.P. VAN CAMP" ON THE "AMENDED MAP OF OCEAN FRONT PROPERTY OF THE MIAMI BEACH IMPROVEMENT COMPANY", AS RECORDED IN PLAT BOOK 5, PAGES 7 AND 8, OF THE PUBLIC RECORDS OF MIAMI-DADE COUNTY, FLORIDA, AND BEING MORE PARTICULARLY DESCRIBED AS FOLLOWS:

THE VERTICALLY ENCLOSED AREA BEGINNING 53.67 FEET ABOVE ELEVATION 0.00 AS PER THE NATIONAL GEODETIC VERTICAL DATUM OF 1929 (NGVD 29) AND EXTENDING 6.33 FEET ABOVE SAID ELEVATION 53.67 FEET TO ELEVATION 60.00 FEET, WHICH SAID ELEVATIONS ARE SET ON THE COURSES SET FORTH BELOW, COMPRISING THE SWIMMING POOL.

COMMENCE AT THE SOUTHWEST CORNER OF THE "R.P. VAN CAMP" TRACT AS PER THE "AMENDED MAP OF OCEAN FRONT PROPERTY OF THE MIAMI BEACH IMPROVEMENT COMPANY" ACCORDING TO THE PLAT THEREOF, AS RECORDED IN PLAT BOOK 5, PAGES 7 AND 8 OF THE PUBLIC RECORDS OF MIAMI-DADE COUNTY, FLORIDA; THENCE NORTH 07°27'50" EAST ALONG THE WESTERLY LINE OF SAID "R.P. VAN CAMP" TRACT, A DISTANCE OF 75.00 FEET TO A POINT ON THE SOUTHERLY LIMITS OF THE FONTAINEBLEAU PROPERTY;

THENCE SOUTH 82°34'49" EAST, ALONG SAID SOUTHERLY LIMITS OF THE FONTAINEBLEAU PROPERTY, A DISTANCE OF 119.03 FEET TO POINT "A";

THENCE NORTH 07°25'11" EAST, A DISTANCE OF 22.05 FEET TO A POINT;

THENCE VERTICALLY FROM AN ELEVATION OF 0.00 FEET TO AN ELEVATION OF 53.67 FEET (N.G.V.D. 29), BEING A VERTICAL DISTANCE OF 53.67 FEET TO POINT OF BEGINNING ONE;

THENCE NORTH 07°25'11" EAST, A DISTANCE OF 22.16 FEET;

THENCE SOUTH 82°34'49" EAST, A DISTANCE OF 55.48 FEET;

THENCE SOUTH 07°25'11" WEST, A DISTANCE OF 22.16 FEET;

THENCE NORTH 82°34'49" WEST, A DISTANCE OF 55.48 FEET TO POINT OF BEGINNING ONE.

SAID LANDS SITUATE LYING AND BEING IN THE CITY OF MIAMI BEACH, MIAMI-DADE COUNTY, FLORIDA, AND CONTAINING 1229 SQUARE FEET, MORE OR LESS.

TOGETHER WITH:

A PORTION OF THE NORTHERLY 125.00 FEET OF THAT CERTAIN TRACT MARKED AND DESIGNATED "R.P. VAN CAMP" ON THE "AMENDED MAP OF OCEAN FRONT PROPERTY OF THE MIAMI BEACH IMPROVEMENT COMPANY", AS RECORDED IN PLAT BOOK 5, PAGES 7 AND 8, OF THE PUBLIC RECORDS OF MIAMI-DADE COUNTY, FLORIDA, AND BEING MORE PARTICULARLY DESCRIBED AS FOLLOWS:

THE VERTICALLY ENCLOSED AREA BEGINNING 58.00 ABOVE ELEVATION 0.00 AS PER THE NATIONAL GEODETIC VERTICAL DATUM OF 1929 (NGVD 29) AND EXTENDING 5.00 FEET ABOVE SAID ELEVATION 58.00 FEET TO ELEVATION 63.00 FEET, WHICH SAID ELEVATIONS ARE SET ON THE COURSES SET FORTH BELOW, COMPRISING THE PRIVATE SPA.

COMMENCE AT THE SAID POINT "A";

THENCE SOUTH 82°34'49" EAST, ALONG SAID SOUTHERLY LIMITS OF THE FONTAINEBLEAU PROPERTY, A DISTANCE OF 109.54 FEET;

THENCE NORTH 07°25'11" EAST, A DISTANCE OF 57.29 FEET TO A POINT;

THENCE VERTICALLY FROM AN ELEVATION OF 0.00 FEET TO AN ELEVATION OF 58.00 FEET (N.G.V.D. 29), BEING A VERTICAL DISTANCE OF 58.00 FEET TO POINT OF BEGINNING TWO;

THENCE NORTH 82°34'49" WEST, A DISTANCE OF 14.16 FEET TO POINT "B";

THENCE NORTH 07°25'11" EAST, A DISTANCE OF 14.00 FEET;

THENCE SOUTH 82°34'49" EAST, A DISTANCE OF 14.16 FEET;

THENCE SOUTH 07°25'11" WEST, A DISTANCE OF 14.00 FEET TO POINT OF BEGINNING TWO.

SAID LANDS SITUATE LYING AND BEING IN THE CITY OF MIAMI BEACH, MIAMI-DADE COUNTY, FLORIDA, AND CONTAINING 198 SQUARE FEET, MORE OR LESS.

PREPARED BY
TROY N. TOWNSEND
PROFESSIONAL SURVEYOR AND MAPPER No. LS 6425
STATE OF FLORIDA

DATE 02-08-05

SEE ATTACHED SKETCH OF DESCRIPTION SHEET 21 OF 2
NOT VALID WITHOUT THE SIGNATURE AND THE ORIGINAL
RAISED SEAL OF A FLORIDA SURVEYOR AND MAPPER.

UPDATES/REVISIONS	DATE	BY	CK'D

NOTE: The undersigned and CONSUL-TECH ENGINEERING, INC. make no representations or guarantees as to the completeness of the information reflected hereon pertaining to easements, right-of-way, set-back lines, reservations, agreements or other matters of record. This instrument is intended to reflect or set forth only those items shown in the reference above. CONSUL-TECH ENGINEERING, INC. did not research the public records for matters affecting the lands shown.

NOTE: This instrument is the property of CONSUL-TECH ENGINEERING, INC. and shall not be reproduced in whole or in part without written consent.

- SKETCH AND DESCRIPTION -

AND:

A PORTION OF THE NORTHERLY 125.00 FEET OF THAT CERTAIN TRACT MARKED AND DESIGNATED "R.P. VAN CAMP" ON THE "AMENDED MAP OF OCEAN FRONT PROPERTY OF THE MIAMI BEACH IMPROVEMENT COMPANY", AS RECORDED IN PLAT BOOK 5, PAGES 7 AND 8, OF THE PUBLIC RECORDS OF MIAMI-DADE COUNTY, FLORIDA, AND BEING MORE PARTICULARLY DESCRIBED AS FOLLOWS:

THE VERTICALLY ENCLOSED AREA BEGINNING 56.30 FEET ABOVE ELEVATION 0.00 AS PER THE NATIONAL GEODETIC VERTICAL DATUM OF 1929 (NGVD 29) AND EXTENDING 10.20 FEET ABOVE SAID ELEVATION 56.30 FEET TO ELEVATION 66.50 FEET, WHICH SAID ELEVATIONS ARE SET ON THE COURSES SET FORTH BELOW, COMPRISING THE PRIVATE SWIMMING POOL.

COMMENCE AT SAID POINT "B", BEING AT AN ELEVATION OF 58.00 FEET PER THE NATIONAL GEODETIC VERTICAL DATUM OF 1929 (NGVD 29); THENCE VERTICALLY FROM AN ELEVATION OF 58.00 FEET TO AN ELEVATION OF 56.30 FEET (NGVD 29), BEING A VERTICAL DISTANCE OF 1.70 FEET; THENCE NORTH 82°34'49" WEST, A DISTANCE OF 4.66 FEET TO POINT OF BEGINNING THREE;

THENCE CONTINUE NORTH 82°34'49" WEST, A DISTANCE OF 36.00 FEET;
 THENCE NORTH 07°25'11" EAST, A DISTANCE OF 14.00 FEET;
 THENCE SOUTH 82°34'49" EAST, A DISTANCE OF 11.16 FEET;
 THENCE NORTH 07°25'11" EAST, A DISTANCE OF 3.17 FEET;
 THENCE SOUTH 82°34'49" EAST, A DISTANCE OF 16.66 FEET;
 THENCE SOUTH 07°25'11" WEST, A DISTANCE OF 3.17 FEET;
 THENCE SOUTH 82°34'49" EAST, A DISTANCE OF 8.16 FEET;
 THENCE SOUTH 07°25'11" WEST, A DISTANCE OF 14.00 FEET TO POINT OF BEGINNING THREE.

SAID LANDS SITUATE LYING AND BEING IN THE CITY OF MIAMI BEACH, MIAMI-DADE COUNTY, FLORIDA, AND CONTAINING 566 SQUARE FEET, MORE OR LESS.

SEE ATTACHED SKETCH OF DESCRIPTION
 SHEET 22 OF 2

PREPARED BY _____ DATE 02-08-05
 TROY N. TOWNSEND
 PROFESSIONAL SURVEYOR AND MAPPER No. LS 6425
 STATE OF FLORIDA

NOT VALID WITHOUT THE SIGNATURE
 AND THE ORIGINAL RAISED SEAL OF
 A FLORIDA SURVEYOR AND MAPPER,

UPDATES/REVISIONS	DATE	BY	CK'D	NOTE
				NOTE: The undersigned and CONSUL-TECH ENGINEERING, INC. make no representations or guarantees as to the completeness of the information reflected hereon pertaining to easements, right-of-way, set-back lines, reservations, agreements or other matters of record. This instrument is intended to reflect or set forth only those items shown in the reference above. CONSUL-TECH ENGINEERING, INC. did not research the public records for matters affecting the lands shown. NOTE: This instrument is the property of CONSUL-TECH ENGINEERING, INC. and shall not be reproduced in whole or in part without written permission of CONSUL-TECH ENGINEERING, INC.

Exhibit "2"

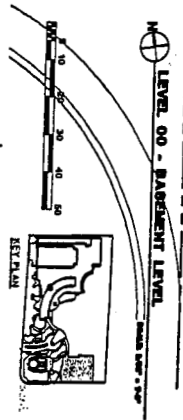
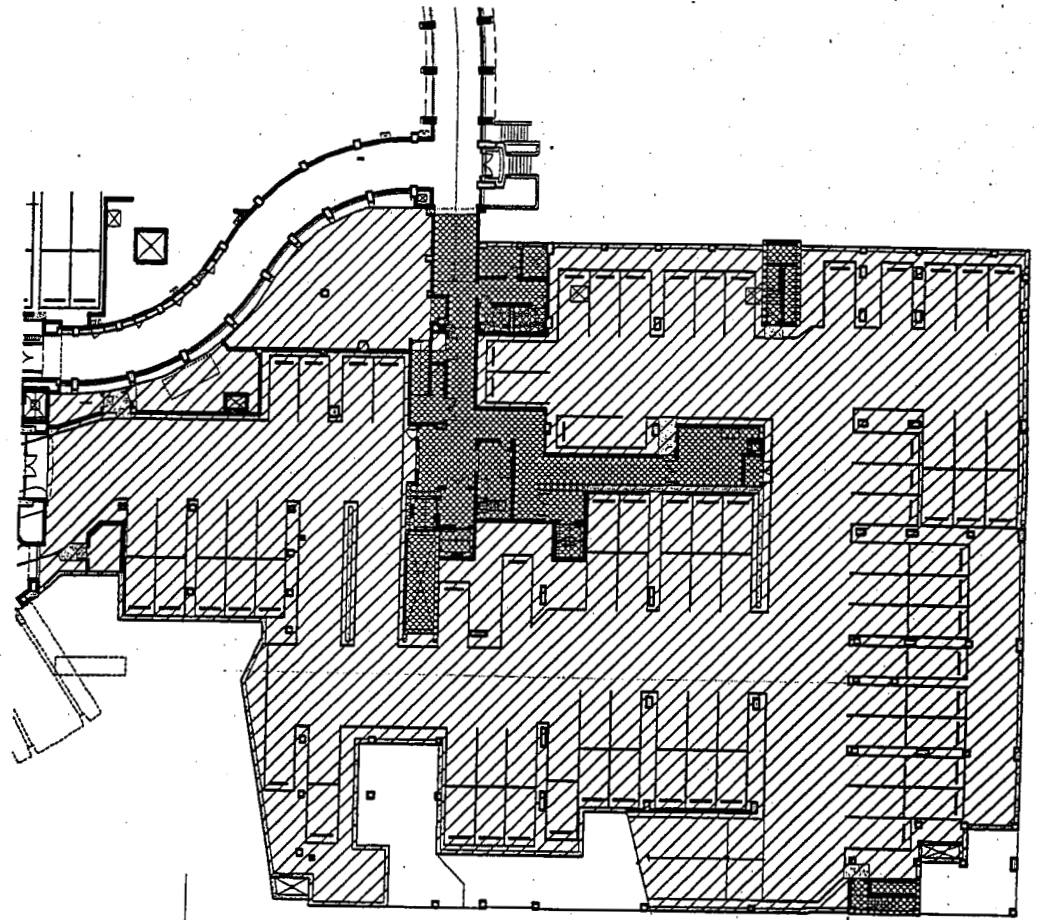

LEVEL 00 - BASEMENT LEVEL

- LEGEND
- ▨ HOTEL UNITS
 - ▩ CONDOMINIUM UNITS
 - ▧ HOTEL-OWNED PROPERTY

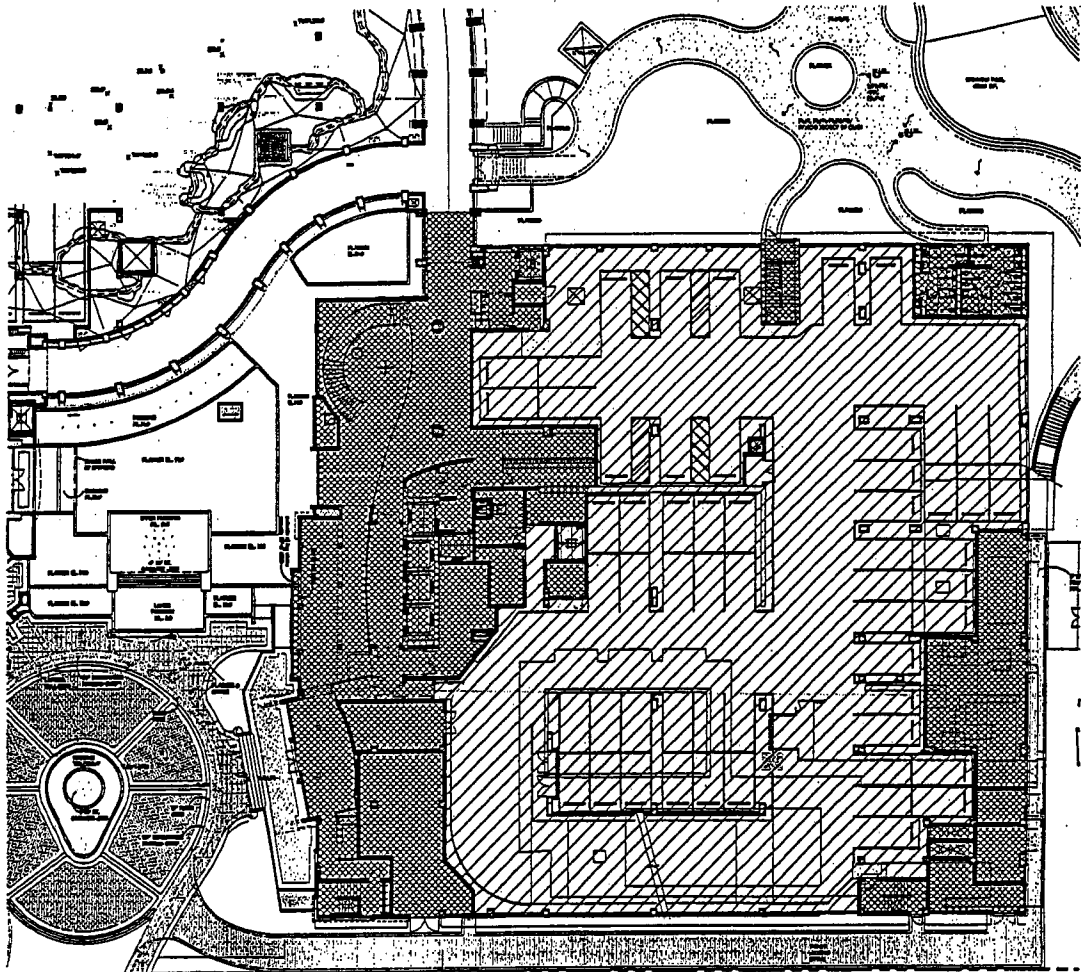

LEGEND
 [Diagonal Hatching] HOTEL UNITS
 [Cross-hatching] CONDOMINIUM UNITS
 [Dotted Hatching] HOTEL-OWNED PROPERTY

LEVEL 1 - LOWER LOBBY

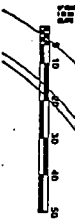

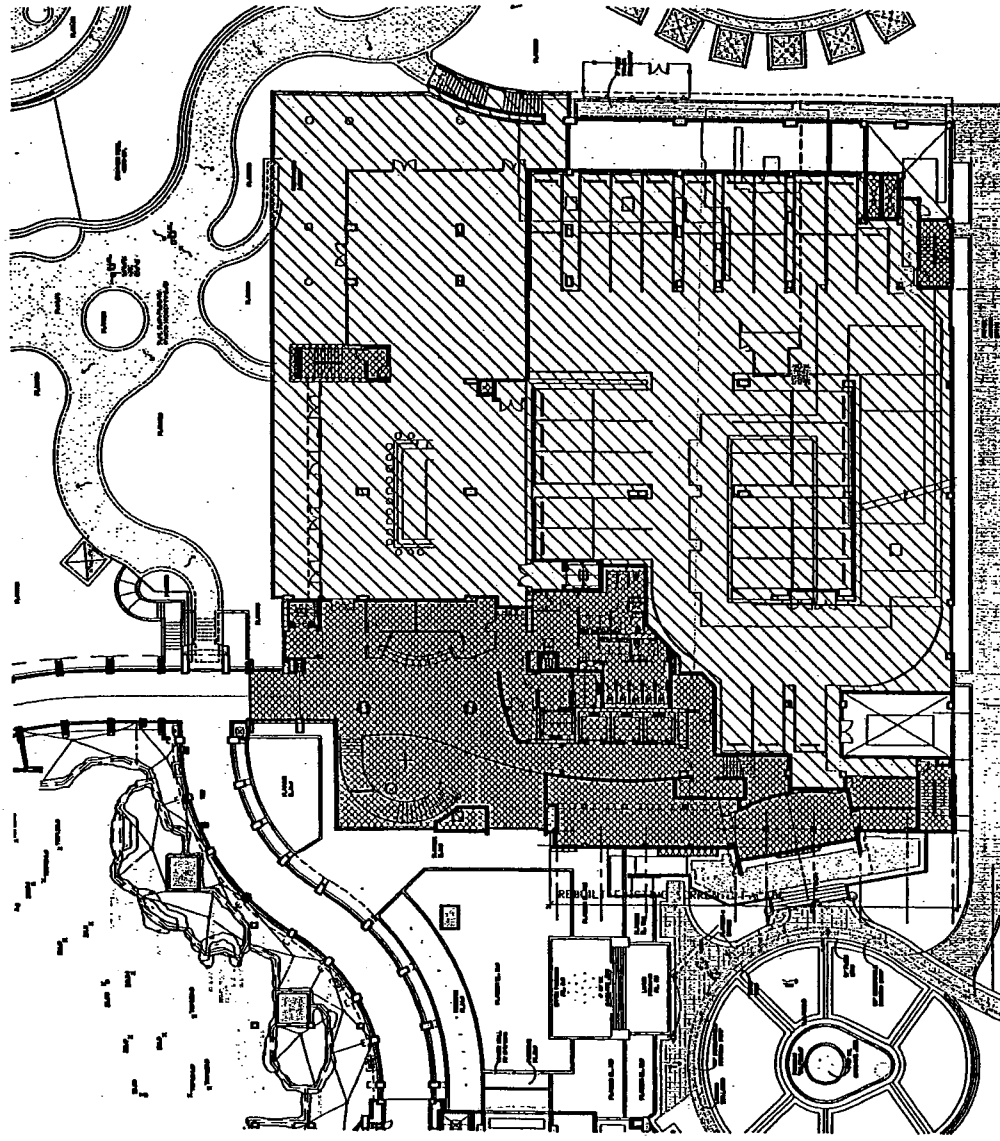

LEGEND
HOTEL UNITS
CONDOMINIUM UNITS
HOTEL-OWNED PROPERTY

LEVEL B - LEVEL LOBBY
SCALE

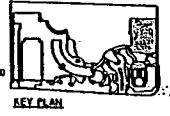
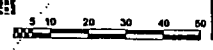

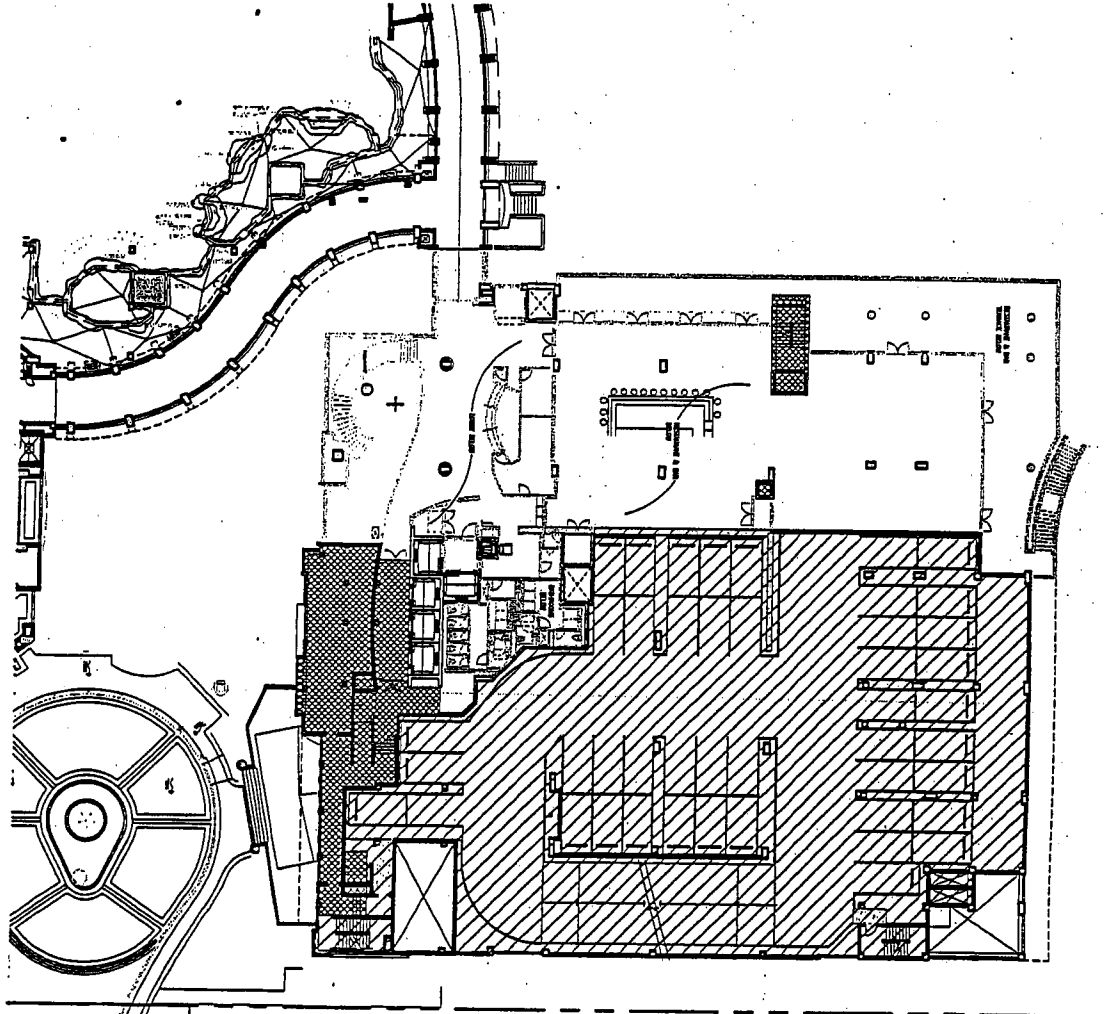



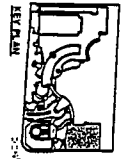

LEGEND
 [Hatched Box] HOTEL UNITS
 [Dotted Box] CONDOMINIUM UNITS
 [Cross-hatched Box] HOTEL-OWNED PROPERTY

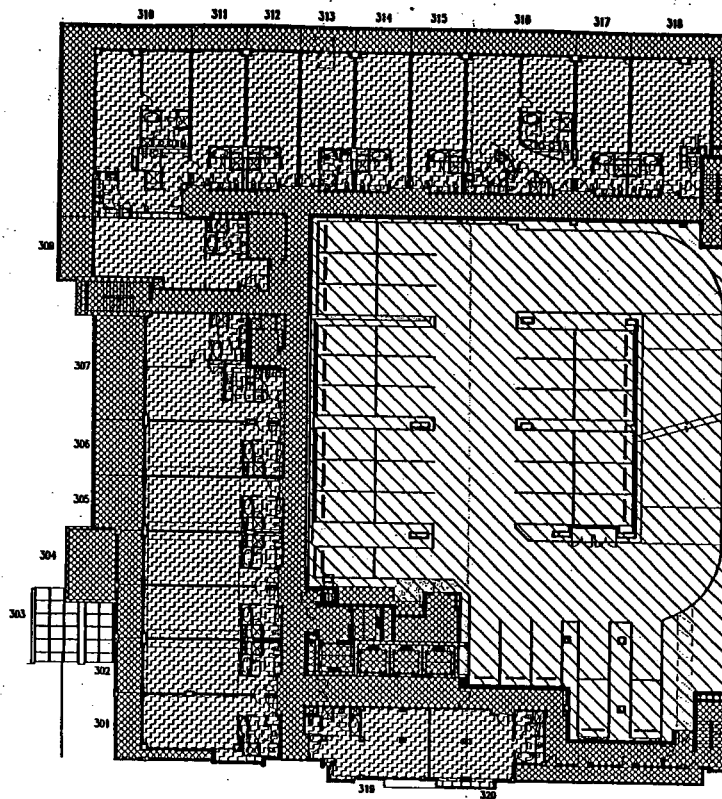
N
 LEVEL 10 - UPPER LEVEL LOBBY & PARK AREA





- LEGEND**
-  HOTEL UNITS
 -  CONDOMINIUM UNITS
 -  HOTEL-OWNED PROPERTY

TOWER 3rd. LEVEL
SCALE 1/8" = 1'-0"

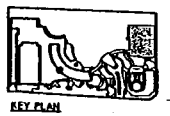
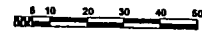

KEY PLAN

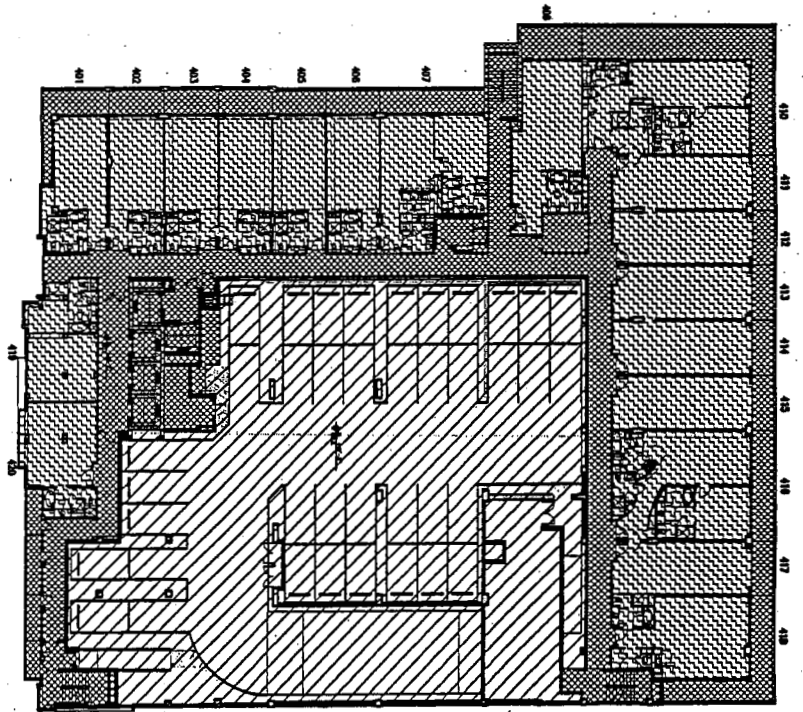

10
 11
 12
 13
 14
 15
 16
 17
 18
 19
 20
 21
 22
 23
 24
 25
 26
 27
 28
 29
 30
 31
 32
 33
 34
 35
 36
 37
 38
 39
 40
 41
 42
 43
 44
 45
 46
 47
 48
 49
 50
 51
 52
 53
 54
 55
 56
 57
 58
 59
 60
 61
 62
 63
 64
 65
 66
 67
 68
 69
 70
 71
 72
 73
 74
 75
 76
 77
 78
 79
 80
 81
 82
 83
 84
 85
 86
 87
 88
 89
 90
 91
 92
 93
 94
 95
 96
 97
 98
 99
 100
 101
 102
 103
 104
 105
 106
 107
 108
 109
 110
 111
 112
 113
 114
 115
 116
 117
 118
 119
 120
 121
 122
 123
 124
 125
 126
 127
 128
 129
 130
 131
 132
 133
 134
 135
 136
 137
 138
 139
 140
 141
 142
 143
 144
 145
 146
 147
 148
 149
 150
 151
 152
 153
 154
 155
 156
 157
 158
 159
 160
 161
 162
 163
 164
 165
 166
 167
 168
 169
 170
 171
 172
 173
 174
 175
 176
 177
 178
 179
 180
 181
 182
 183
 184
 185
 186
 187
 188
 189
 190
 191
 192
 193
 194
 195
 196
 197
 198
 199
 200
 201
 202
 203
 204
 205
 206
 207
 208
 209
 210
 211
 212
 213
 214
 215
 216
 217
 218
 219
 220
 221
 222
 223
 224
 225
 226
 227
 228
 229
 230
 231
 232
 233
 234
 235
 236
 237
 238
 239
 240
 241
 242
 243
 244
 245
 246
 247
 248
 249
 250
 251
 252
 253
 254
 255
 256
 257
 258
 259
 260
 261
 262
 263
 264
 265
 266
 267
 268
 269
 270
 271
 272
 273
 274
 275
 276
 277
 278
 279
 280
 281
 282
 283
 284
 285
 286
 287
 288
 289
 290
 291
 292
 293
 294
 295
 296
 297
 298
 299
 300
 301
 302
 303
 304
 305
 306
 307
 308
 309
 310
 311
 312
 313
 314
 315
 316
 317
 318
 319
 320
 321
 322
 323
 324
 325
 326
 327
 328
 329
 330
 331
 332
 333
 334
 335
 336
 337
 338
 339
 340
 341
 342
 343
 344
 345
 346
 347
 348
 349
 350
 351
 352
 353
 354
 355
 356
 357
 358
 359
 360
 361
 362
 363
 364
 365
 366
 367
 368
 369
 370
 371
 372
 373
 374
 375
 376
 377
 378
 379
 380
 381
 382
 383
 384
 385
 386
 387
 388
 389
 390
 391
 392
 393
 394
 395
 396
 397
 398
 399
 400
 401
 402
 403
 404
 405
 406
 407
 408
 409
 410
 411
 412
 413
 414
 415
 416
 417
 418
 419
 420
 421
 422
 423
 424
 425
 426
 427
 428
 429
 430
 431
 432
 433
 434
 435
 436
 437
 438
 439
 440
 441
 442
 443
 444
 445
 446
 447
 448
 449
 450
 451
 452
 453
 454
 455
 456
 457
 458
 459
 460
 461
 462
 463
 464
 465
 466
 467
 468
 469
 470
 471
 472
 473
 474
 475
 476
 477
 478
 479
 480
 481
 482
 483
 484
 485
 486
 487
 488
 489
 490
 491
 492
 493
 494
 495
 496
 497
 498
 499
 500





TOWER 4TH LEVEL

SCALE: 1/8" = 1'-0"

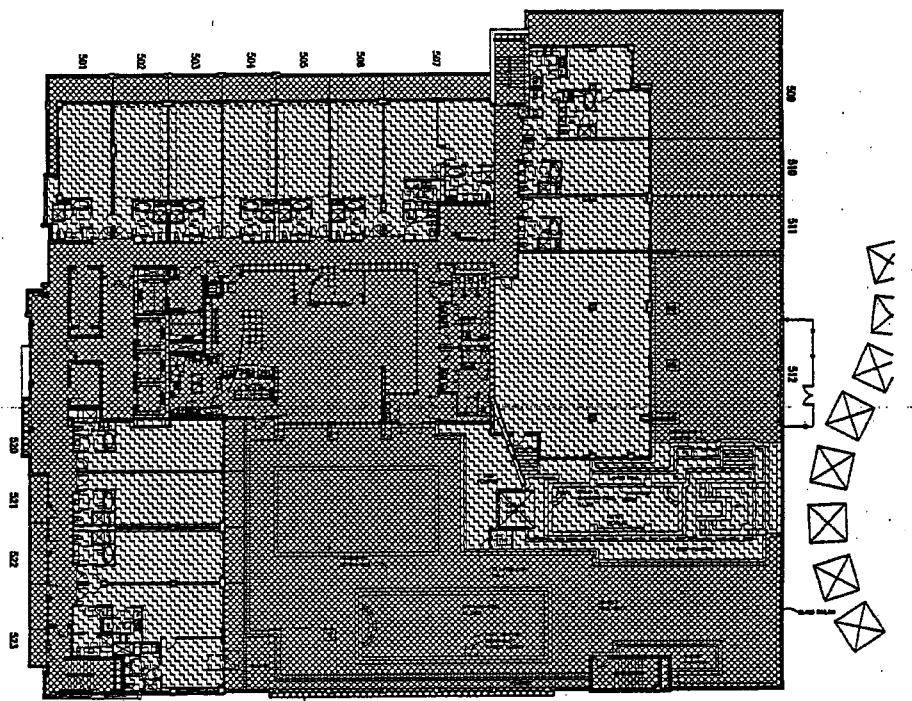

- LEGEND**
-  HOTEL UNITS
 -  CONDOMINIUM UNITS
 -  HOTEL-OWNED PROPERTY



TOWER 5TH LEVEL

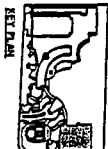

- LEGEND
- HOTEL UNITS
 - CONDOMINIUM UNITS
 - HOTEL-OWNED PROPERTY

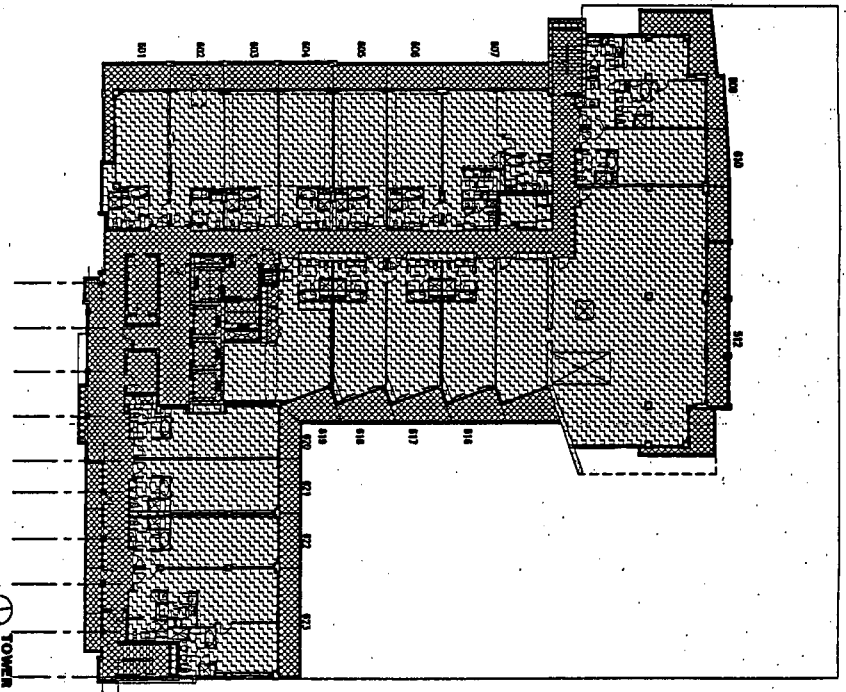



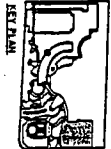

⊕ TOWER 07H LEVELS

Scale: 1/8" = 1'-0"

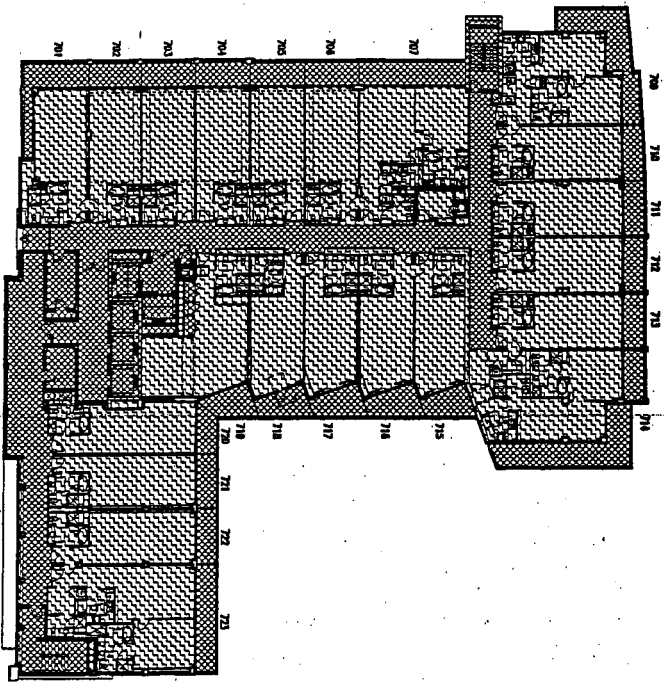

- LEGEND
- HOTEL UNITS
 - CONDOMINIUM UNITS
 - HOTEL-OWNED PROPERTY



- LEGEND
-  HOTEL UNITS
 -  CONDOMINIUM UNITS
 -  HOTEL-OWNED PROPERTY

⊕ TOWER 7TH LEVEL



LEGEND
 [Cross-hatched] HOTEL UNITS
 [Diagonal lines] CONDOMINIUM UNITS
 [Dotted] HOTEL-OWNED PROPERTY

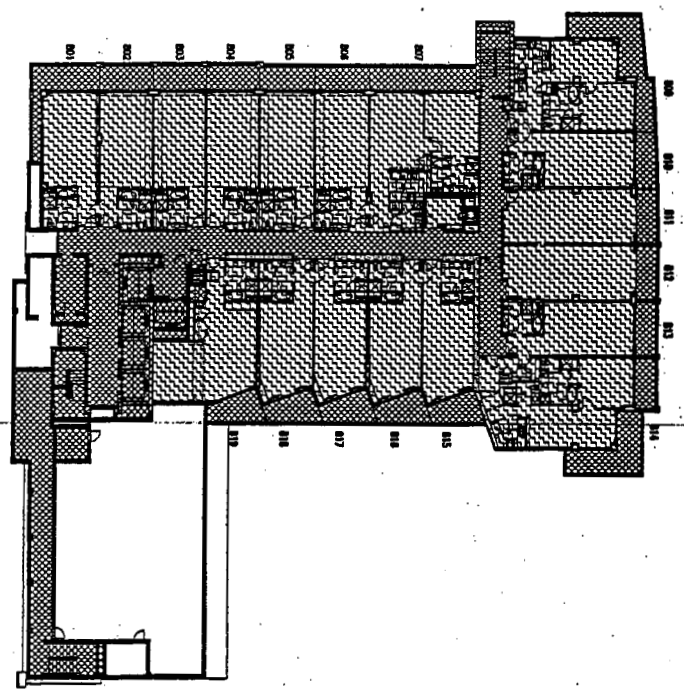

TOWER 07TH LEVELS
 1/8" = 1'-0"

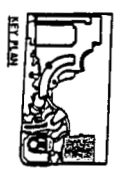

NO. OF UNITS PER SECTOR	
A-21	272

Fontainebleau Hotel

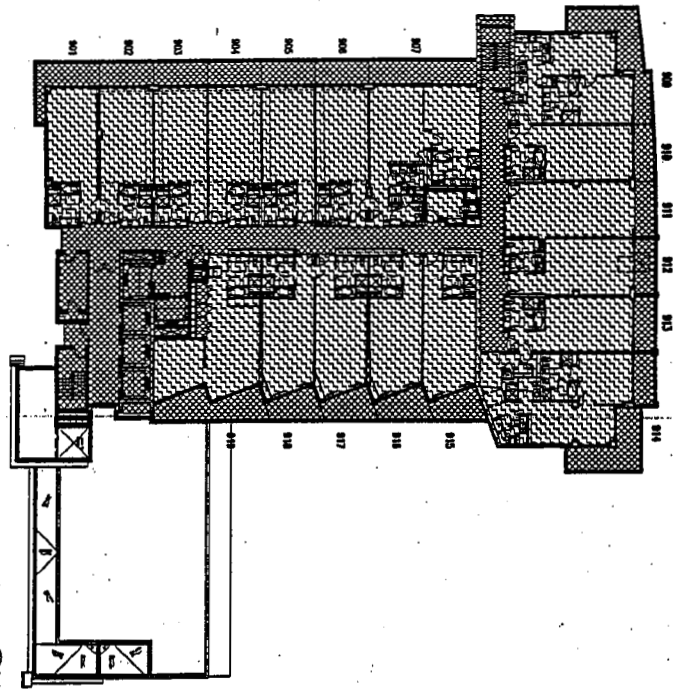

↑
TOWER 07H

Scale: 1/8" = 1'-0"



- LEGEND
- HOTEL UNITS
 - CONDOMINIUM UNITS
 - HOTEL-OWNED PROPERTY

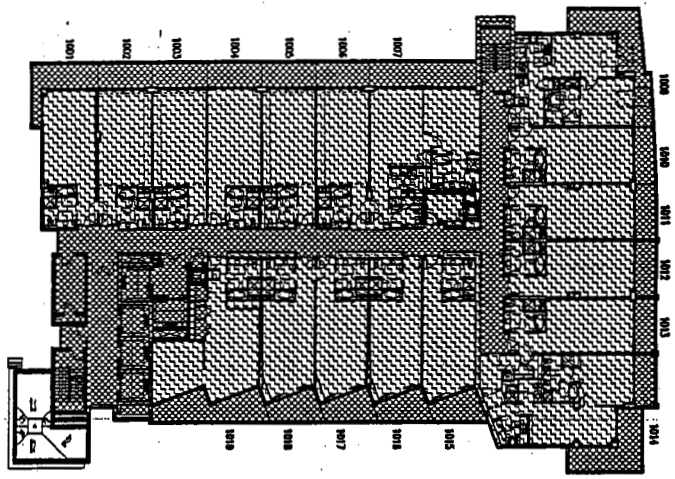



TOWER NORTH LEVELS
 SCALE: 1/8" = 1'-0"

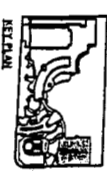

LEGEND
 [Solid Black Box] HOTEL UNITS
 [Diagonal Line Box] CONDOMINIUM UNITS
 [Grid Box] HOTEL-OWNED PROPERTY

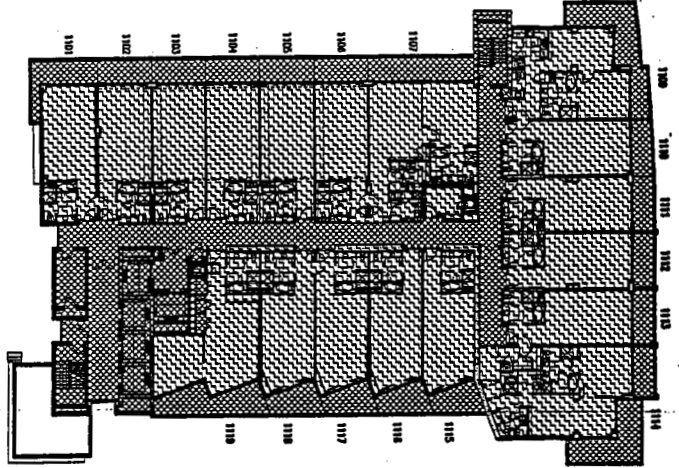

L



TOWER 11TH
 NORTH ARROW

LEGEND
 HOTEL UNITS
 CONDOMINIUM UNITS
 HOTEL-OWNED PROPERTY

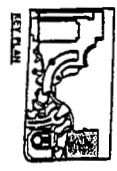

LEGEND
 [Cross-hatch pattern] HOTEL UNITS
 [Diagonal line pattern] CONDOMINIUM UNITS
 [Dotted pattern] HOTEL-OWNED PROPERTY

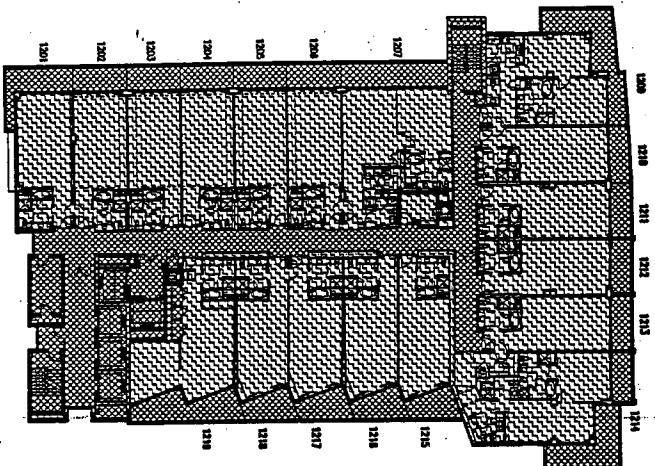

N
 TOWER 21TH LEVELS
 SCALE: 1/8" = 1'-0"



LEGEND
 [Cross-hatch pattern] HOTEL UNITS
 [Diagonal lines pattern] CONDOMINIUM UNITS
 [Dotted pattern] HOTEL-OWNED PROPERTY

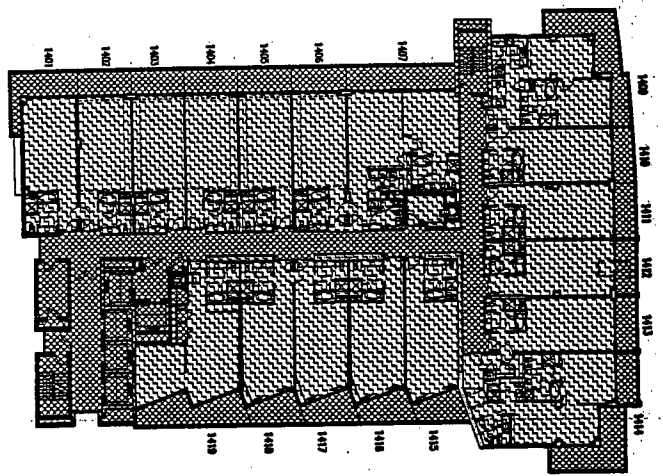

⊕ TOWER EAST
 1400 1401 1402 1403 1404 1405 1406 1407 1408 1409 1410 1411 1412 1413 1414

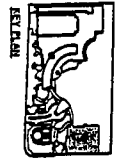

LEGEND
 [Cross-hatch pattern] HOTEL UNITS
 [Diagonal lines pattern] CONDOMINIUM UNITS
 [Dotted pattern] HOTEL-OWNED PROPERTY

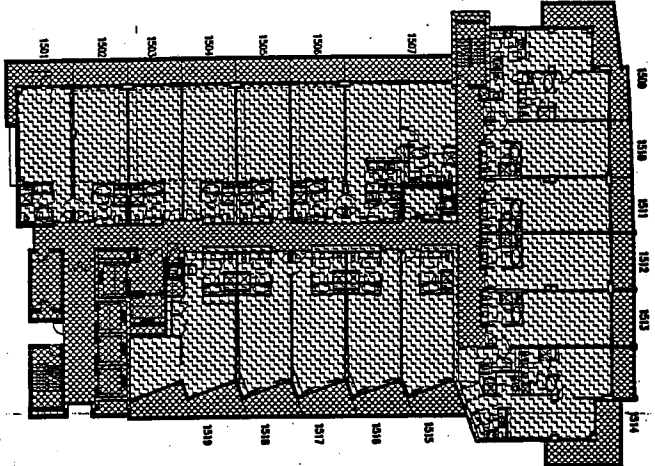

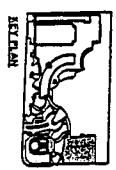

N
 TOWER WITH LEVELS
 SCALE: 1/8" = 1'-0"

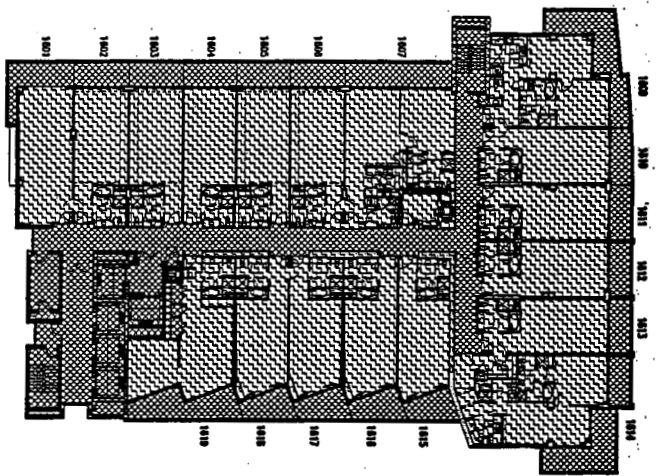





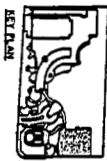

 NORTH
 SCALE: 1/8" = 1'-0"

LEGEND
 HOTEL UNITS
 CONDOMINIUM UNITS
 HOTEL-OWNED PROPERTY

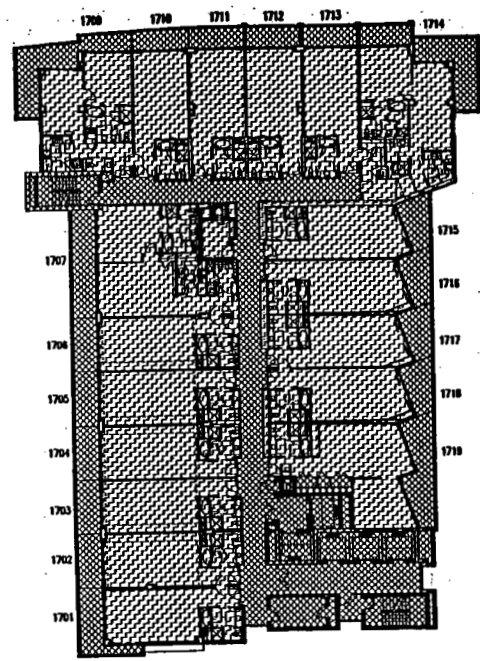

- LEGEND
-  HOTEL UNITS
 -  CONDOMINIUM UNITS
 -  HOTEL-OWNED PROPERTY



N  TOWER 17TH GRAPH DATE - 9-97

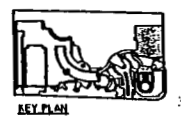
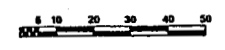



 17TH FLOOR

LEGEND
 [Cross-hatch pattern] HOTEL UNITS
 [Diagonal lines pattern] CONDOMINIUM UNITS
 [Dotted pattern] HOTEL-OWNED PROPERTY

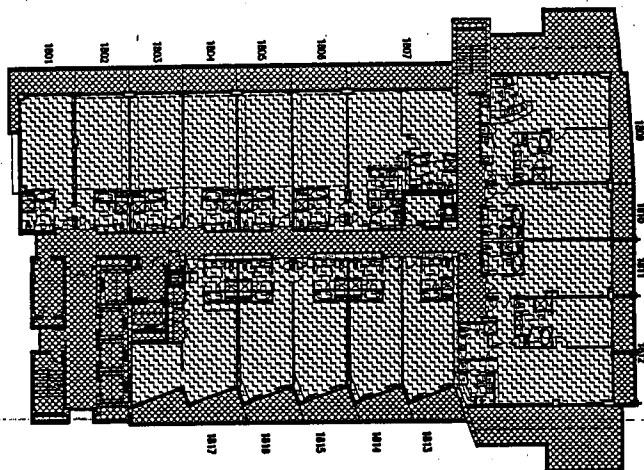

⊕ TOWER 27TH LEVEL
 SCALE: 1/8" = 1'-0"



LEGEND
 [Hatched Box] HOTEL UNITS
 [Cross-hatched Box] CONDOMINIUM UNITS
 [Dotted Box] HOTEL-OWNED PROPERTY

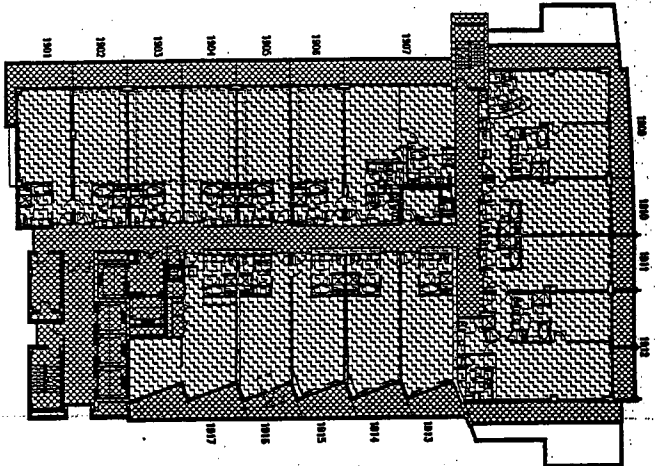

⊕ TOWER 1978 LEVEL
 SCALE: 1/8" = 1'-0"

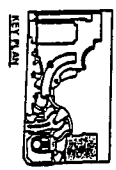
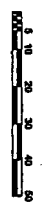

Exhibit "3"
Schedule of Percentage Shares
of Ownership of Common Elements
and Common Surplus and of
Sharing of Common Expenses

Unit		Percent Allocation
Floor	Type	
301	D2	0.18773040%
302	D	0.16328856%
303	D	0.16328856%
304	D	0.16328856%
305	D	0.16328856%
306	D	0.16328856%
307	D1	0.28756883%
309	J	0.23238748%
310	H	0.33137259%
311	G	0.15672644%
312	G	0.15672644%
313	G	0.15672644%
314	G	0.15672644%
315	G	0.15672644%
318	I	0.31544395%
317	G	0.15672644%
318	G2	0.22556092%
319	N	0.18602376%
320	M	0.17863724%
401	D2	0.18773040%
402	D	0.16328856%
403	D	0.16328856%
404	D	0.16328856%
405	D	0.16328856%
406	D	0.16328856%
407	D1	0.28756883%
409	J	0.23238748%
410	H	0.33137259%
411	G	0.15672644%
412	G	0.15672644%
413	G	0.15672644%
414	G	0.15672644%
415	G	0.15672644%
416	I	0.31544395%
417	G	0.15672644%
418	G2	0.22556092%
419	N	0.18602376%
420	M	0.17863724%
501	D2	0.18773040%
502	D	0.16328856%
503	D	0.16328856%
504	D	0.16328856%
505	D	0.16328856%
506	D	0.16328856%
507	D1	0.28756883%
509	A	0.23124972%
510	E2	0.15644200%
511	E	0.15644200%
512	TS	1.61647249%
520	K2	0.18639740%
521	K	0.17635280%
522	K	0.17635280%
523	L	0.31914167%
601	D2	0.18773040%
602	D	0.16328856%
603	D	0.16328856%
604	D	0.16328856%
605	D	0.16328856%
606	D	0.16328856%
607	D1	0.28756883%

Unit		Percent Allocation
Floor	Type	
609	A	0.23124972%
610	E2	0.15644200%
616	F	0.16156192%
617	F2	0.16156192%
618	F	0.16156192%
619	C1	0.24717836%
620	K2	0.16639740%
621	K	0.17635280%
622	K	0.17635280%
623	L	0.31914167%
701	D2	0.16773040%
702	D	0.16326856%
703	D	0.16326856%
704	D	0.16326856%
705	D	0.16326856%
706	D	0.16326856%
707	D1	0.28756883%
709	A	0.23124972%
710	E2	0.15644200%
711	E	0.15644200%
712	E	0.15644200%
713	E2	0.15644200%
714	B	0.28216447%
715	Fa	0.15644200%
716	F	0.16156192%
717	F2	0.16156192%
718	F	0.16156192%
719	C1	0.24717836%
720	K2	0.16639740%
721	K	0.17635280%
722	K	0.17635280%
723	L	0.31914167%
801	Db	0.17237064%
802	D	0.16326856%
803	D	0.16326856%
804	D	0.16326856%
805	D	0.16326856%
806	D	0.16326856%
807	D1	0.28756883%
809	A	0.23124972%
810	E2	0.15644200%
811	E	0.15644200%
812	E	0.15644200%
813	E2	0.15644200%
814	B	0.28216447%
815	Fa	0.15644200%
816	F	0.16156192%
817	F2	0.16156192%
818	F	0.16156192%
819	C1	0.24717836%
901	Db	0.17237064%
902	D	0.16326856%
903	D	0.16326856%
904	D	0.16326856%
905	D	0.16326856%
906	D	0.16326856%
907	D1	0.28756883%
909	A	0.23124972%
910	E2	0.15644200%
911	E	0.15644200%

Unit		Percent Allocation
Floor	Type	
912	E	0.15644200%
913	E2	0.15644200%
914	B	0.28216447%
915	Fa	0.15644200%
916	F	0.16156192%
917	F2	0.16156192%
918	F	0.16156192%
919	C2	0.24063624%
1001	Db	0.17237064%
1002	D	0.16326856%
1003	D	0.16326856%
1004	D	0.16326856%
1005	D	0.16326856%
1006	D	0.16326856%
1007	D1	0.28756883%
1009	A	0.23124972%
1010	E2	0.15644200%
1011	E	0.15644200%
1012	E	0.15644200%
1013	E2	0.15644200%
1014	B	0.28216447%
1015	Fa	0.15644200%
1016	F	0.16156192%
1017	F2	0.16156192%
1018	F	0.16156192%
1019	C2	0.24063624%
1101	Db	0.17237064%
1102	D	0.16326856%
1103	D	0.16326856%
1104	D	0.16326856%
1105	D	0.16326856%
1106	D	0.16326856%
1107	D1	0.28756883%
1109	A	0.23124972%
1110	E2	0.15644200%
1111	E	0.15644200%
1112	E	0.15644200%
1113	E2	0.15644200%
1114	B	0.28216447%
1116	Fa	0.15644200%
1116	F	0.16156192%
1117	F2	0.16156192%
1118	F	0.16156192%
1119	C2	0.24063624%
1201	Db	0.17237064%
1202	D	0.16326856%
1203	D	0.16326856%
1204	D	0.16326856%
1205	D	0.16326856%
1206	D	0.16326856%
1207	D1	0.28756883%
1209	A	0.23124972%
1210	E2	0.15644200%
1211	E	0.15644200%
1212	E	0.15644200%
1213	E2	0.15644200%
1214	B	0.28216447%
1216	Fa	0.15644200%
1216	F	0.16156192%
1217	F2	0.16156192%

Unit		Percent Allocation
Floor	Type	
1218	F	0.16156192%
1219	C2	0.24063624%
1401	Db	0.17237064%
1402	D	0.16326856%
1403	D	0.16326856%
1404	D	0.16326856%
1406	D	0.16326856%
1406	D	0.16326856%
1407	D1	0.28756883%
1409	A	0.23124972%
1410	E2	0.15644200%
1411	E	0.15644200%
1412	E	0.15644200%
1413	E2	0.15644200%
1414	B	0.28216447%
1416	Fa	0.15644200%
1416	F	0.16156192%
1417	F2	0.16156192%
1418	F	0.16156192%
1419	C2	0.24063624%
1501	Db	0.17237064%
1502	D	0.16326856%
1503	D	0.16326856%
1504	D	0.16326856%
1505	D	0.16326856%
1506	D	0.16326856%
1507	D1	0.28756883%
1509	A	0.23124972%
1510	E2	0.15644200%
1511	E	0.15644200%
1512	E	0.15644200%
1513	E2	0.15644200%
1514	B	0.28216447%
1516	Fa	0.15644200%
1516	F	0.16156192%
1517	F2	0.16156192%
1518	F	0.16156192%
1519	C2	0.24063624%
1601	Db	0.17237064%
1602	D	0.16326856%
1603	D	0.16326856%
1604	D	0.16326856%
1605	D	0.16326856%
1606	D	0.16326856%
1607	D1	0.28756883%
1609	A	0.23124972%
1610	E2	0.15644200%
1611	E	0.15644200%
1612	E	0.15644200%
1613	E2	0.15644200%
1614	B	0.28216447%
1615	Fa	0.15644200%
1616	F	0.16156192%
1617	F2	0.16156192%
1618	F	0.16156192%
1619	C2	0.24063624%
1701	Db	0.17237064%
1702	D	0.16326856%
1703	D	0.16326856%
1704	D	0.16326856%

Unit		Floor	Type	Percent Allocation
Hotel Unit	Commercial			
1708	A			0.23124972%
1707	D1			0.29769883%
1706	D			0.16329856%
1705	D			0.16329856%
1710	E2			0.15644200%
1711	E			0.15644200%
1712	E			0.15644200%
1713	E2			0.15644200%
1714	B			0.28216447%
1715	Fa			0.15644200%
1716	F			0.16166192%
1717	F2			0.16166192%
1718	F			0.16166192%
1719	C2			0.24063624%
1801	Dp			0.17237064%
1802	D			0.16329856%
1803	D			0.16329856%
1804	D			0.16329856%
1805	D			0.16329856%
1806	D			0.16329856%
1807	D1			0.28769883%
1808	A2			0.30349747%
1810	E			0.15644200%
1811	E			0.15644200%
1812	B2			0.35043007%
1813	Fa			0.15644200%
1814	F			0.16166192%
1816	F2			0.16166192%
1817	C2			0.24063624%
1801	Dp			0.17237064%
1802	D			0.16329856%
1803	D			0.16329856%
1804	D			0.16329856%
1805	D			0.16329856%
1806	D			0.16329856%
1807	D1			0.28769883%
1808	A2			0.30349747%
1810	E			0.15644200%
1811	E			0.15644200%
1812	B2			0.35043007%
1813	Fa			0.15644200%
1814	F			0.16166192%
1816	F2			0.16166192%
1817	C2			0.24063624%
1817	C2			0.24063624%
1901	Dp			0.17237064%
1902	D			0.16329856%
1903	D			0.16329856%
1904	D			0.16329856%
1905	D			0.16329856%
1906	D			0.16329856%
1907	D1			0.28769883%
1908	A2			0.30349747%
1910	E			0.15644200%
1911	E			0.15644200%
1912	B2			0.35043007%
1913	Fa			0.15644200%
1914	F			0.16166192%
1916	F2			0.16166192%
1917	C2			0.24063624%
Hotel Unit				44.87262310%
Total				100.0000000%

Exhibit "4"

BY-LAWS
OF
FONTAINEBLEAU III OCEAN CLUB CONDOMINIUM ASSOCIATION, INC.

*A corporation not for profit organized
under the laws of the State of Florida*

1. Identity. These are the By-Laws of FONTAINEBLEAU III OCEAN CLUB CONDOMINIUM ASSOCIATION, INC. (the "Association"), a corporation not for profit incorporated under the laws of the State of Florida, and organized for the purposes set forth in its Articles of Incorporation.
 - 1.1 Fiscal Year. The fiscal year of the Association shall be the twelve month period commencing January 1st and terminating December 31st of each year. The provisions of this subsection 1.1 may be amended at any time by a majority of the Board of Directors of the Association.
 - 1.2 Seal. The seal of the Association shall bear the name of the corporation, the word "Florida", the words "Corporation Not for Profit", and the year of incorporation.
2. Definitions. For convenience, these By-Laws shall be referred to as the "By-Laws" and the Articles of Incorporation of the Association as the "Articles". The other terms used in these By-Laws shall have the same definitions and meanings as those set forth in the Declaration for FONTAINEBLEAU III OCEAN CLUB CONDOMINIUM, unless herein provided to the contrary, or unless the context otherwise requires.
3. Members.
 - 3.1 Annual Meeting. The annual members' meeting shall be held on the date, at the place and at the time determined by the Board of Directors from time to time, provided that there shall be an annual meeting every calendar year and, to the extent possible, no later than thirteen (13) months after the last preceding annual meeting. The purpose of the meeting shall be, except as provided herein to the contrary, to elect Directors, and to transact any other business authorized to be transacted by the members, or as stated in the notice of the meeting sent to Unit Owners in advance thereof. Unless changed by the Board of Directors, the first annual meeting shall be held in the month of October following the year in which the Declaration is filed.
 - 3.2 Special Meetings. Special members' meetings shall be held at such places as provided herein for annual meetings, and may be called by the President or by a majority of the Board of Directors of the Association, and must be called by the President or Secretary upon receipt of a written request from a majority of the members of the Association. The business conducted at a special meeting shall be limited to those agenda items specifically identified in the notice of the meeting. Special meetings may also be called by Unit Owners in the manner provided for in the Act. Notwithstanding the foregoing: (i) as to special meetings regarding the adoption of the Condominium's estimated operating budget, reference should be made to Section 10.1 of these By-Laws; and (ii) as to special meetings regarding recall of Board members, reference should be made to Section 4.3 of these By-Laws.
 - 3.3 Participation by Unit Owners. Subject to the following and such further reasonable restrictions as may be adopted from time to time by the Board, Unit Owners shall have the right to speak at the annual and special meetings of the Unit Owners, committee meetings and Board meetings with reference to all designated agenda items. A Unit Owner does not have the right to speak with respect to items not specifically designated on the agenda, provided, however, that the Board may permit a Unit Owner to speak on such items in its discretion. Every Unit Owner who desires to speak at a meeting, may do so, provided that the Unit Owner has filed a written request with the Secretary of the Association not less than twenty-four (24) hours prior to the scheduled time for commencement of the meeting. Unless waived by the chairman of the meeting (which may be done in the chairman's sole and absolute discretion and without being deemed to constitute a waiver as to any other subsequent speakers), all Unit Owners speaking at a meeting shall be limited to a maximum of three (3) minutes per speaker. Any Unit Owner may tape record or videotape a meeting, subject to the following and such further reasonable restrictions as may be adopted from time to time by the Board:
 - (a) The only audio and video equipment and devices which Unit Owners are authorized to utilize at any such meeting is equipment which does not produce distracting sound or light emissions;

- (b) Audio and video equipment shall be assembled and placed in position in advance of the commencement of the meeting;
- (c) Anyone videotaping or recording a meeting shall not be permitted to move about the meeting room in order to facilitate the recording; and
- (d) At least forty-eight (48) hours (or twenty-four (24) hours with respect to a Board meeting) prior written notice shall be given to the Secretary of the Association by any Unit Owner desiring to make an audio or video taping of the meeting.

3.4 Notice of Meeting; Waiver of Notice. Notice of a meeting of members (annual or special), stating the time and place and the purpose(s) for which the meeting is called, shall be given by the President or Secretary. A copy of the notice shall be posted at a conspicuous place on the Condominium Property. The notice of an annual or special meeting shall be hand delivered, electronically transmitted or sent by regular mail to each Unit Owner, unless the Unit Owner waives in writing the right to receive notice of the annual meeting by mail. The delivery or mailing shall be to the address of the member as last furnished to the Association by the Unit Owner. However, if a Unit is owned by more than one (1) person, the Association shall provide notice, for meetings and all other purposes, to that one (1) address initially identified for that purpose by the Developer and thereafter as one (1) or more of the Owners of the Unit shall so advise the Association in writing, or if no address is given or if the Owners disagree, notice shall be sent to the address for the Owner as set forth on the deed of the Unit. The posting and mailing of the notice for either special or annual meetings, which notice shall incorporate an identification of agenda items, shall be effected not less than fourteen (14) continuous days, nor more than sixty (60) days, prior to the date of the meeting. The Board shall adopt by rule, and give notice to Unit Owners of, a specific location on the Condominium Property upon which all notices of members' meetings shall be posted. In lieu of or in addition to the physical posting of notice of any meeting of the Unit Owners on the Condominium Property, the Association may, by reasonable rule, adopt a procedure for conspicuously posting and repeatedly broadcasting the notice and the agenda on a closed-circuit cable television system serving the Association, if any. However, if broadcast notice is used in lieu of a notice posted physically on the Condominium Property, the notice and agenda must be broadcast at least four times every broadcast hour of each day that a posted notice is otherwise required. When broadcast notice is provided, the notice and agenda must be broadcast in a manner and for a sufficient continuous length of time so as to allow an average reader to observe the notice and read and comprehend the entire content of the notice and the agenda.

Notice of specific meetings may be waived before or after the meeting and the attendance of any member (or person authorized to vote for such member), either in person or by proxy, shall constitute such member's waiver of notice of such meeting, and waiver of any and all objections to the place of the meeting, the time of the meeting or the manner in which it has been called or convened, except when his (or his authorized representative's) attendance is for the express purpose of objecting at the beginning of the meeting to the transaction of business because the meeting is not lawfully called.

An officer of the Association, or the manager or other person providing notice of the meeting shall provide an affidavit or United States Postal Service certificate of mailing, to be included in the official records of the Association, affirming that notices of meetings were posted and mailed or hand delivered in accordance with this Section and Section 718.112(2)(d) of the Act, to each Unit Owner at the appropriate address for such Unit Owner. No other proof of notice of a meeting shall be required.

3.5 Quorum. A quorum at members' meetings shall be attained by the presence, either in person or by proxy (limited or general), of persons entitled to cast in excess of thirty three and one third percent (33 1/3%) of the votes of members entitled to vote at the subject meeting.

3.6 Voting.

- (a) Number of Votes. Except as provided in Section 3.11 hereof, in any meeting of members, the Owners of each Residential Unit shall be entitled to cast one (1) vote for each Unit owned and the Hotel Unit Owner shall be entitled to cast one hundred twenty five (125) votes. The vote of a Unit shall not be divisible.
- (b) Majority Vote. The acts approved by a majority of the votes present in person or by proxy at a meeting at which a quorum shall have been attained shall be binding upon all Unit Owners for all purposes, except where otherwise provided by law, the Declaration, the Articles or these By-Laws. As used in these By-Laws, the Articles or the Declaration, the terms "majority of the Unit Owners" and "majority of the members" shall mean a majority of the votes entitled to be cast by the members and not a majority of the members

themselves and shall further mean more than fifty percent (50%) of the then total authorized votes present in person or by proxy and voting at any meeting of the Unit Owners at which a quorum shall have been attained. Similarly, if some greater percentage of members is required herein or in the Declaration or Articles, it shall mean such greater percentage of the votes of members and not of the members themselves.

- (c) Voting Member. If a Unit is owned by one person, that person's right to vote shall be established by the roster of members. If a Unit is owned by more than one person, those persons (including husbands and wives) shall decide among themselves as to who shall cast the vote of the Unit. In the event that those persons cannot so decide, no vote shall be cast. A person casting a vote for a Unit shall be presumed to have the authority to do so unless the President or the Board of Directors is otherwise notified. If a Unit is owned by a corporation, partnership, limited liability company, trust or any other lawful entity, the person entitled to cast the vote for the Unit shall be designated by a certificate signed by persons having lawful authority to bind the corporation, partnership, limited liability company, trust or other lawful entity and filed with the Secretary of the Association. Such person need not be a Unit Owner. Those certificates shall be valid until revoked or until superseded by a subsequent certificate or until a change in the ownership of the Unit concerned. A certificate designating the person entitled to cast the vote for a Unit may be revoked by any record owner of an undivided interest in the Unit. If a certificate designating the person entitled to cast the vote for a Unit for which such certificate is required is not on file or has been revoked, the vote attributable to such Unit shall not be considered in determining whether a quorum is present, nor for any other purpose, and the total number of authorized votes in the Association shall be reduced accordingly until such certificate is filed.

- 3.7 Proxies. Votes to be cast at meetings of the Association membership may be cast in person or by proxy. Except as specifically provided herein, Unit Owners may not vote by general proxy, but may vote by limited proxies substantially conforming to the limited proxy form approved by the Division. Limited proxies shall be permitted to the extent permitted by the Act. No proxy, limited or general, shall be used in the election of Board members. General proxies may be used for other matters for which limited proxies are not required and may also be used in voting for nonsubstantive changes to items for which a limited proxy is required and given. A proxy may be made by any person entitled to vote, but shall only be valid for the specific meeting for which originally given and any lawful adjourned meetings thereof. In no event shall any proxy be valid for a period longer than 90 days after the date of the first meeting for which it was given. Every proxy shall be revocable at any time at the pleasure of the person executing it. A proxy must be in writing, signed by the person authorized to cast the vote for the Unit (as above described), name the person(s) voting by proxy and the person authorized to vote for such person(s) and filed with the Secretary before the appointed time of the meeting, or before the time to which the meeting is adjourned. Each proxy shall contain the date, time and place of the meeting for which it is given and, if a limited proxy, shall set forth the matters on which the proxy holder may vote and the manner in which the vote is to be cast. There shall be no limitation on the number of proxies which may be held by any person (including a designee of the Developer). If a proxy expressly provides, any proxy holder may appoint, in writing, a substitute to act in its place. If such provision is not made, substitution is not permitted.

- 3.8 Adjourned Meetings. If any proposed meeting cannot be organized because a quorum has not been attained, the members who are present, either in person or by proxy, may adjourn the meeting from time to time until a quorum is present, provided notice of the newly scheduled meeting is given in the manner required for the giving of notice of a meeting. Except as required above, proxies given for the adjourned meeting shall be valid for the newly scheduled meeting unless revoked for reasons other than the new date of the meeting.

- 3.9 Order of Business. If a quorum has been attained, the order of business at annual members' meetings, and, if applicable, at other members' meetings, shall be:

- (a) Collect any ballots not yet cast;
- (b) Call to order by President;
- (c) Appointment by the President of a chairman of the meeting (who need not be a member or a Director);
- (d) Appointment of inspectors of election;
- (e) Counting of Ballots for Election of Directors;

inspection statement listing any defects in workmanship or materials (only within the boundaries of the Unit itself) which Buyer discovers. If any item listed is actually defective in workmanship or materials in Seller's opinion (keeping in mind the construction standards applicable in Miami-Dade County, Florida for similar property), Seller will be obligated to correct those defects at its cost within a reasonable period of time after closing, but Seller's obligation to correct will not be grounds for deferring the closing, nor for imposing any condition on closing. **No escrows or holdbacks of closing funds will be permitted.** Buyer understands and agrees that Seller's obligation to correct defects in the Unit noted during the pre-closing inspection shall automatically terminate (with Seller having no further obligations for the repair of such items) upon the earlier of: (i) the date that Buyer obtains a permit for construction and/or improvement of the Unit, or (ii) the date that Buyer commences construction and/or improvement of the Unit, whether or not a permit has been obtained. If Buyer fails to take advantage of the right to a pre-closing inspection on the date and time scheduled, Seller will not be obligated to reschedule an inspection prior to closing and Buyer shall be deemed to have accepted the Unit in its AS-IS condition.

From and after the closing, Buyer hereby grants Seller and its agents access to the Unit at reasonable times during normal business hours to complete any necessary repairs to the Unit. If Buyer cannot be present at the time such work is to be performed to facilitate completion of such work, Buyer hereby authorizes Seller, its agents, employees and contractors to enter the Unit for such purposes using a master key or a key maintained by the Association. If Buyer cannot or elects not to be present at the time that Seller performs any such work, Buyer hereby waives and releases Seller (its partners, contractors, subcontractors, employees, agents, designees and assigns) from any and all claims that Buyer may have against Seller (its partners, contractors, subcontractors, employees, agents, designees and assigns) relating to damage to or theft of property from the Unit that is not due to the negligence or intentional act of Seller or its partners, contractors, subcontractors, employees, agents, designees and/or assigns. Seller shall have no further obligation to complete punch list items if Seller has submitted three (3) written requests to Buyer for entry over a thirty (30) day period after closing, and access to the Unit has been denied for any reason.

Buyer acknowledges that all matters pertaining to the initial construction of the Unit will be handled by Seller and Seller's representatives. Buyer agrees not to interfere with or interrupt any workers at the site of the Unit. No personal inspections (other than the one pre-closing inspection) will be permitted. Buyer may not commence any work on the Unit, other than prepaid options or extras that Seller agrees in writing to provide, until after closing. **Buyer recognizes that Seller is not obligated to agree to provide extras or options.**

Buyer can examine Seller's Plans and Specifications at Seller's business office, located on site during regular business hours by making an appointment to do so in advance.

9. Closing Date. Buyer understands and agrees that Seller has the right to schedule the date, time and place for closing, which shall in no event be later than six (6) months following the Outside Date. Before Seller can require Buyer to close, however, two things must be done:

(a) Seller must record the Declaration and related documents in the Miami-Dade County public records; and

(b) Seller must obtain a temporary, partial or permanent certificate of occupancy for or covering the Unit from the proper governmental agency (a certificate of occupancy is the official approval needed before a unit may be lived in), but, subject and subordinate to the provisions of paragraphs 8 and 27 of this Agreement (without limiting the generality of those provisions by this specific reference), the Common Elements, the Shared Components and other portions of the Condominium Property need not then have certificates of occupancy, nor be completed, provided, however, that the certification of substantial completion described in Section 718.104(4)(e), Florida Statutes, shall be included as an exhibit to the Declaration, as recorded. Seller does, however, agree to complete those amenities, roads, streets and facilities for water, sewer, gas, and electric service within a reasonable time following closing and otherwise in accordance with the terms of the Property Report dated as of April 26, 2005.

Buyer will be given at least ten (10) days' notice of the date, time and place of closing. Seller is authorized to postpone the closing for any reason and Buyer will close on the new date, time and place specified in a notice of postponement (as long as at least three (3) days' notice of the new date, time and place is given). A change of time or place of closing only (one not involving a change of date) will not require any additional notice period. Any formal notice of closing, postponement or rescheduling may be given by Seller orally, by telephone, telegraph, telex, telecopy, mail or other reasonable means of communication at Seller's option. All of these notices will be sent or directed to the address, or given by use of the information specified on Page 1 of this Agreement unless Seller has received written notice from Buyer of any change prior to the date the notice is given. These notices will be effective on the date given or mailed (as appropriate). An affidavit of one of Seller's employees or agents stating that this notice was given or mailed will be conclusive.

After the notice is given or mailed, and if requested in writing by Buyer, Seller will send a written confirmation of the closing, together with a draft closing statement and other pertinent information and instructions. This written confirmation is given merely as a courtesy and is not the formal notice to close. Accordingly, it does not need to be received by any particular date prior to closing. Buyer agrees, however, to follow all instructions given in any formal notice and written confirmation.

Buyer's Initials:

Purchase Agreement

Seller's Initials

Association. The Association is not liable for the contents of the information sheets prepared by the candidates. In order to reduce costs, the Association may print or duplicate the information sheets on both sides of the paper.

The election of Directors shall be by written ballot or voting machine. Proxies shall in no event be used in electing the Board at general elections or to fill vacancies caused by resignation or otherwise, provided, however, that limited proxies may be used to fill a vacancy resulting from the recall of a Director, in the manner provided by the rules of the Division. Elections shall be decided by a plurality of those ballots and votes cast. There shall be no quorum requirement, however at least twenty percent (20%) of the eligible voters must cast a ballot in order to have a valid election of members of the Board. There shall be no cumulative voting.

Notwithstanding the provisions of this Section 4.2, an election is not required unless more candidates file notices of intent to run or are nominated than vacancies exist on the Board.

4.3 Vacancies and Removal.

- (a) Except as to vacancies resulting from removal of Directors by members (as addressed in subsection (b) below), vacancies in the Board of Directors occurring between annual meetings of members shall be filled by a majority vote of the remaining Directors at any Board meeting (even if the remaining Directors constitute less than a quorum), provided that all vacancies in directorships to which Directors were appointed by the Developer pursuant to the provisions of paragraph 4.15 hereof shall be filled by the Developer without the necessity of any meeting.
- (b) Any Director elected by the members (other than the Developer) may be removed by concurrence of a majority of the voting interests of the members at a special meeting of members called for that purpose or by written agreement signed by a majority of all voting interests. The vacancy in the Board of Directors so created shall be filled by the members at a special meeting of the members called for such purpose, or by the Board of Directors, in the case of removal by a written agreement unless said agreement also designates a new Director to take the place of the one removed. The conveyance of all Units owned by a Director in the Condominium (other than appointees of the Developer or Directors who were not Unit Owners) shall constitute the resignation of such Director.
- (c) Anything to the contrary herein notwithstanding, until a majority of the Directors are elected by members other than the Developer of the Condominium, neither the first Directors of the Association, nor any Directors replacing them, nor any Directors named by the Developer, shall be subject to removal by members other than the Developer. The first Directors and Directors replacing them may be removed and replaced by the Developer without the necessity of any meeting.
- (d) If a vacancy on the Board of Directors results in the inability to obtain a quorum of Directors in accordance with these By-Laws, and the remaining Directors fail to fill the vacancy by appointment of a Director in accordance with applicable law, then any Owner may apply to the Circuit Court within whose jurisdiction the Condominium lies for the appointment of a receiver to manage the affairs of the Association. At least thirty (30) days prior to applying to the Circuit Court, the Unit Owner shall mail to the Association and post in a conspicuous place on the Condominium Property a notice describing the intended action and giving the Association an opportunity to fill the vacancy(ies) in accordance with these By-Laws. If, during such time, the Association fails to fill the vacancy(ies), the Unit Owner may proceed with the petition. If a receiver is appointed, the Association shall be responsible for the salary of the receiver, court costs and attorneys' fees. The receiver shall have all powers and duties of a duly constituted Board of Directors, and shall serve until the Association fills the vacancy(ies) on the Board sufficient to constitute a quorum in accordance with these By-Laws.

4.4 Term. Except as provided herein to the contrary, the term of each Director's service shall extend until the next annual meeting of the members and subsequently until his successor is duly elected and has taken office, or until he is removed in the manner elsewhere provided. Notwithstanding the foregoing, any Director designated by the Developer shall serve at the pleasure of the Developer and may be removed and replaced by the Developer at any time.

4.5 Organizational Meeting. The organizational meeting of newly-elected or appointed Directors shall be held within ten (10) days of their election or appointment. The Directors calling the organizational meeting shall give at least three (3) days advance notice thereof, stating the time and place of the meeting.

- 4.6 Meetings. Meetings of the Board of Directors may be held at such time and place as shall be determined, from time to time, by a majority of the Directors. Meetings of the Board of Directors may be held by telephone conference, with those Directors attending by telephone counted toward the quorum requirement, provided that a telephone speaker must be used so that the conversation of those Directors attending by telephone may be heard by the Directors and any Unit Owners attending such meeting in person. Notice of meetings shall be given to each Director, personally or by mail, telephone or telegraph, and shall be transmitted at least three (3) days prior to the meeting. Meetings of the Board of Directors and any Committee thereof at which a quorum of the members of that Committee are present shall be open to all Unit Owners. Any Unit Owner may tape record or videotape meetings of the Board, in accordance with the rules of the Division. The right to attend such meetings includes the right to speak at such meetings with respect to all designated agenda items. The Association may adopt reasonable rules governing the frequency, duration and manner of Unit Owner statements. Adequate notice of such meetings, which notice shall specifically incorporate an identification of agenda items, shall be posted conspicuously on the Condominium Property at least forty-eight (48) continuous hours preceding the meeting, except in the event of an emergency. Any item not included on the notice may be taken up on an emergency basis by at least a majority plus one of the members of the Board. Such emergency action shall be noticed and ratified at the next regular meeting of the Board. Notwithstanding the foregoing, written notice of any meeting of the Board at which nonemergency special assessments, or at which amendment to rules regarding unit use will be proposed, discussed or approved, shall be mailed, delivered or electronically transmitted to all Unit Owners and posted conspicuously on the Condominium Property not less than fourteen (14) continuous days prior to the meeting. Evidence of compliance with this fourteen (14) continuous day notice shall be made by an affidavit executed by the Secretary of the Association and filed among the official records of the Association. The Board shall adopt by rule, and give notice to Unit Owners of, a specific location on the Condominium Property upon which all notices of Board and/or Committee meetings shall be posted. In lieu of or in addition to the physical posting of notice of any meeting of the Board on the Condominium Property, the Association may, by reasonable rule, adopt a procedure for conspicuously posting and repeatedly broadcasting the notice and the agenda on a closed-circuit cable television system serving the Association, if any. However, if broadcast notice is used in lieu of a notice posted physically on the Condominium Property, the notice and agenda must be broadcast at least four times every broadcast hour of each day that a posted notice is otherwise required. When broadcast notice is provided, the notice and agenda must be broadcast in a manner and for a sufficient continuous length of time so as to allow an average reader to observe the notice and read and comprehend the entire content of the notice and the agenda. Special meetings of the Directors may be called by the President, and must be called by the President or Secretary at the written request of one-third (1/3) of the Directors or where required by the Act. A Director or member of a Committee of the Board of Directors may submit in writing his or her agreement or disagreement with any action taken at a meeting that the board member or committee member did not attend, but the agreement or disagreement may not be used as a vote for or against the action taken and may not be used for purposes of creating a quorum.
- 4.7 Waiver of Notice. Any Director may waive notice of a meeting before or after the meeting and that waiver shall be deemed equivalent to the due receipt by said Director of notice. Attendance by any Director at a meeting shall constitute a waiver of notice of such meeting, and a waiver of any and all objections to the place of the meeting, to the time of the meeting or the manner in which it has been called or convened, except when a Director states at the beginning of the meeting, or promptly upon arrival at the meeting, any objection to the transaction of affairs because the meeting is not lawfully called or convened.
- 4.8 Quorum. A quorum at Directors' meetings shall consist of a majority of the entire Board of Directors. The acts approved by a majority of those present at a meeting at which a quorum is present shall constitute the acts of the Board of Directors, except when approval by a greater number of Directors is specifically required by the Declaration, the Articles or these By-Laws.
- 4.9 Adjourned Meetings. If, at any proposed meeting of the Board of Directors, there is less than a quorum present, the majority of those present may adjourn the meeting from time to time until a quorum is present, provided notice of such newly scheduled meeting is given as required hereunder. At any newly scheduled meeting, any business that might have been transacted at the meeting as originally called may be transacted as long as notice of such business to be conducted at the rescheduled meeting is given, if required (e.g., with respect to budget adoption).
- 4.10 Joinder in Meeting by Approval of Minutes. The joinder of a Director in the action of a meeting by signing and concurring in the minutes of that meeting shall constitute the approval of that Director of the business conducted at the meeting, but such joinder shall not be used as a vote for or against any particular action taken and shall not allow the applicable Director to be counted as being present for purposes of quorum.

- 4.11 Presiding Officer. The presiding officer at the Directors' meetings shall be the President (who may, however, designate any other Unit Owner to preside).
- 4.12 Order of Business. If a quorum has been attained, the order of business at Directors' meetings shall be:
- (a) Proof of due notice of meeting;
 - (b) Reading and disposal of any unapproved minutes;
 - (c) Reports of officers and committees;
 - (d) Election of officers;
 - (e) Unfinished business;
 - (f) New business;
 - (g) Adjournment.

Such order may be waived in whole or in part by direction of the presiding officer.

- 4.13 Minutes of Meetings. The minutes of all meetings of the Board of Directors shall be kept in a book available for inspection by Unit Owners, or their authorized representatives, and Board members at any reasonable time. The Association shall retain these minutes for a period of not less than seven years.
- 4.14 Committees. The Board may by resolution also create Committees and appoint persons to such Committees and vest in such Committees such powers and responsibilities as the Board shall deem advisable.
- 4.15 Proviso. Notwithstanding anything to the contrary contained in this Section 4 or otherwise, the Board shall consist of three (3) Directors during the period that the Developer is entitled to appoint a majority of the Directors, as hereinafter provided. The Developer shall have the right to appoint all of the members of the Board of Directors until Unit Owners other than the Developer own fifteen percent (15%) or more of the Units in the Condominium. When Unit Owners other than the Developer own fifteen percent (15%) or more of the Units in the Condominium that will be operated ultimately by the Association, the Unit Owners other than the Developer shall be entitled to elect not less than one-third (1/3) of the members of the Board of Directors. Upon the election of such Director(s), the Developer shall forward to the Division of Florida Land Sales, Condominiums and Mobile Homes the name and mailing address of the Director(s) elected. Unit Owners other than the Developer are entitled to elect not less than a majority of the members of the Board of Directors: (a) three years after fifty (50%) percent of the Units that will be operated ultimately by the Association have been conveyed to purchasers; (b) three months after ninety (90%) percent of the Units that will be operated ultimately by the Association have been conveyed to purchasers; (c) when all of the Units that will be operated ultimately by the Association have been completed, some of them have been conveyed to purchasers, and none of the others are being offered for sale by the Developer in the ordinary course of business; (d) when some of the Units have been conveyed to purchasers, and none of the others are being constructed or offered for sale by the Developer in the ordinary course of business; or (e) seven (7) years after recordation of the Declaration, whichever occurs first. The Developer is entitled (but not obligated) to elect at least one (1) member of the Board of Directors as long as the Developer holds for sale in the ordinary course of business five percent (5%) of the Units that will be operated ultimately by the Association.

The Developer may transfer control of the Association to Unit Owners other than the Developer prior to such dates in its sole discretion by causing enough of its appointed Directors to resign, whereupon it shall be the affirmative obligation of Unit Owners other than the Developer to elect Directors and assume control of the Association. Provided at least sixty (60) days' notice of Developer's decision to cause its appointees to resign is given to Unit Owners, neither the Developer, nor such appointees, shall be liable in any manner in connection with such resignations even if the Unit Owners other than the Developer refuse or fail to assume control.

Within seventy-five (75) days after the Unit Owners other than the Developer are entitled to elect a member or members of the Board of Directors, or sooner if the Developer has elected to accelerate such event as aforesaid, the Association shall call, and give not less than sixty (60) days' notice of an election for the member or members of the Board of Directors. The notice may be given by any Unit Owner if the Association fails to do so.

At the time the Unit Owners other than the Developer elect a majority of the members of the Board of Directors of the Association, the Developer shall relinquish control of the Association and such Unit Owners shall accept control. At that time (except as to subparagraph (g), which may be ninety (90) days thereafter) Developer shall deliver to the Association, at Developer's expense, all property of the Unit Owners and of the Association held or controlled by the Developer, including, but not limited to, the following items, if applicable to the Condominium:

- (a) The original or a photocopy of the recorded Declaration of Condominium, and all amendments thereto. If a photocopy is provided, the Developer must certify by affidavit that it is a complete copy of the actual recorded Declaration.
- (b) A certified copy of the Articles of Incorporation of the Association.
- (c) A copy of the By-Laws of the Association.
- (d) The minute book, including all minutes, and other books and records of the Association.
- (e) Any rules and regulations which have been adopted.
- (f) Resignations of resigning officers and Board members who were appointed by the Developer.
- (g) The financial records, including financial statements of the association, and source documents from the incorporation of the Association through the date of the turnover. The records shall be audited for the period from the incorporation of the Association or from the period covered by the last audit, if applicable, by an independent certified public accountant. All financial statements shall be prepared in accordance with generally accepted accounting principles and shall be audited in accordance with generally accepted auditing standards as prescribed by the Florida Board of Accountancy. The accountant performing the audit shall examine to the extent necessary supporting documents and records, including the cash disbursements and related paid invoices to determine if expenditures were for Association purposes, and billings, cash receipts and related records to determine that the Developer was charged and paid the proper amounts of Assessments.
- (h) Association funds or the control thereof.
- (i) All tangible personal property that is the property of the Association or is or was represented by the Developer to be part of the Common Elements or is ostensibly part of the Common Elements, and an inventory of such property.
- (j) A copy of the plans and specifications utilized in the construction or remodeling of Improvements and the supplying of equipment, and for the construction and installation of all mechanical components serving the Improvements and the Condominium Property, with a certificate, in affidavit form, of an officer of the Developer or an architect or engineer authorized to practice in Florida, that such plans and specifications represent, to the best of their knowledge and belief, the actual plans and specifications utilized in the construction and improvement of the Condominium Property and the construction and installation of the mechanical components serving the Improvements and the Condominium Property.
- (k) A list of the names and addresses of all contractors, subcontractors and suppliers, of which Developer had knowledge at any time in the development of the Condominium, utilized in the construction or remodeling of the improvements and the landscaping of the Condominium and/or Association Property.
- (l) Insurance policies.
- (m) Copies of any Certificates of Occupancy which may have been issued for the Condominium Property.
- (n) Any other permits issued by governmental bodies applicable to the Condominium Property in force or issued within one (1) year prior to the date the Unit Owners take control of the Association.
- (o) All written warranties of contractors, subcontractors, suppliers and manufacturers, if any, that are still effective.

- (p) A roster of Unit Owners and their addresses and telephone numbers, if known, as shown on the Developer's records.
- (q) Leases of the Common Elements and other leases to which the Association is a party, if applicable.
- (r) Employment contracts or service contracts in which the Association is one of the contracting parties, or service contracts in which the Association or Unit Owners have an obligation or responsibility, directly or indirectly, to pay some or all of the fee or charge of the person or persons performing the service.
- (s) All other contracts to which the Association is a party.

5. Authority of the Board.

5.1 Powers and Duties. The Board of Directors shall have the powers and duties necessary for the administration of the affairs of the Condominium and may take all acts, through the proper officers of the Association, in executing such powers, except such acts which by law, the Declaration, the Articles or these By-Laws may not be delegated to the Board of Directors by the Unit Owners. Such powers and duties of the Board of Directors shall include, without limitation (except as limited elsewhere herein), the following:

- (a) Operating and maintaining all Common Elements and the Association Property.
- (b) Determining the expenses required for the operation of the Association and the Common Elements of the Condominium.
- (c) Employing and dismissing the personnel necessary for the maintenance and operation of the Common Elements and the Association Property.
- (d) Adopting and amending rules and regulations concerning the details of the operation and use of the Common Elements of the Condominium and Association Property, subject to a right of the Unit Owners to overrule the Board as provided in Section 14 hereof.
- (e) Maintaining bank accounts on behalf of the Association and designating the signatories required therefor.
- (f) Purchasing, leasing or otherwise acquiring title to, or an interest in, property in the name of the Association, or its designee, for the use and benefit of its members. The power to acquire personal property shall be exercised by the Board and the power to acquire real property shall be exercised as described herein and in the Declaration.
- (g) Purchasing, leasing or otherwise acquiring Units or other property, including, without limitation, Units at foreclosure or other judicial sales, all in the name of the Association, or its designee.
- (h) Selling, leasing, mortgaging or otherwise dealing with Units acquired, and subleasing Units leased, by the Association, or its designee.
- (i) Organizing corporations and appointing persons to act as designees of the Association in acquiring title to or leasing Units or other property.
- (j) Obtaining and reviewing insurance for the Common Elements and Association Property.
- (k) Making repairs, additions and improvements to, or alterations of, the Common Elements and Association Property, and repairs to and restoration of the Common Elements and Association Property, in accordance with the provisions of the Declaration after damage or destruction by fire or other casualty, or as a result of condemnation or eminent domain proceedings or otherwise.
- (l) Enforcing obligations of the Unit Owners, allocating profits and expenses and taking such other actions as shall be deemed necessary and proper for the sound management of the Condominium.
- (m) Levying fines against appropriate Unit Owners for violations of the rules and regulations established by the Association to govern the conduct of such Unit Owners. No fine shall be levied except after giving reasonable notice and opportunity for a hearing to the affected Unit Owner and, if applicable, his tenant, licensee or invitee. The hearing must be held before a committee of other Unit Owners. If the committee does not agree with

the fine, the fine may not be levied. No fine may exceed \$100.00 per violation, however, a fine may be levied on the basis of each day of a continuing violation with a single notice and opportunity for hearing, provided however, that no such fine shall in the aggregate exceed \$1,000.00. No fine shall become a lien upon a Unit.

- (n) Purchasing or leasing Units for use by resident superintendents and other similar persons or for the general use and enjoyment of the Unit Owners.
- (o) Borrowing money on behalf of the Association or the Condominium when required in connection with the operation, care, upkeep and maintenance of Common Elements (if the need for the funds is unanticipated) or the acquisition of real property, and granting mortgages on and/or security interests in Association owned property; provided, however, that the consent of the Owners of at least two-thirds (2/3rds) of the Units represented at a meeting at which a quorum has been attained in accordance with the provisions of these By-Laws shall be required for the borrowing of any sum which would cause the total outstanding indebtedness of the Association to exceed \$10,000.00. If any sum borrowed by the Board of Directors on behalf of the Condominium pursuant to the authority contained in this subparagraph 5.1(o) is not repaid by the Association, a Unit Owner who pays to the creditor such portion thereof as his interest in his Common Elements bears to the interest of all the Unit Owners in the Common Elements shall be entitled to obtain from the creditor a release of any judgment or other lien which said creditor shall have filed or shall have the right to file against, or which will affect, such Owner's Unit. Notwithstanding the foregoing, the restrictions on borrowing contained in this subparagraph 5.1(o) shall not apply if such indebtedness is entered into for the purpose of financing insurance premiums and/or for the purpose of responding to emergency situations which may arise with respect to the Common Elements and/or Condominium Property, which action may be undertaken solely by the Board of Directors, without requiring a vote of the Unit Owners.
- (p) Subject to the provisions of Section 5.2 below, contracting for the management and maintenance of the Condominium and Association Property and authorizing a management agent (who may be an affiliate of the Developer) to assist the Association in carrying out its powers and duties by performing such functions as the submission of proposals, collection of Assessments, preparation of records, enforcement of rules and maintenance, repair, and replacement of the Common Elements and Association Property with such funds as shall be made available by the Association for such purposes. The Association and its officers shall, however, retain at all times the powers and duties granted by the Declaration, the Articles, these By-Laws and the Act, including, but not limited to, the making of Assessments, promulgation of rules and execution of contracts on behalf of the Association.
- (q) At its discretion, but within the parameters of the Act, authorizing Unit Owners or other persons to use portions of the Common Elements or Association Property for private parties and gatherings and imposing reasonable charges for such private use.
- (r) Executing all documents or consents, on behalf of all Unit Owners (and their mortgagees), required by all governmental and/or quasi-governmental agencies in connection with land use and development matters (including, without limitation, plats, waivers of plat, unities of title, covenants in lieu thereof, etc.), and in that regard, each Owner, by acceptance of the deed to such Owner's Unit, and each mortgagee of a Unit Owner by acceptance of a lien on said Unit, appoints and designates the President of the Association as such Owner's agent and attorney-in-fact to execute any and all such documents or consents.
- (s) Responding to Unit Owner inquiries in accordance with Section 718.112(2)(a)2, F.S.
- (t) Exercising (i) all powers specifically set forth in the Declaration, the Articles, these By-Laws and in the Act, (ii) all powers incidental thereto, and (iii) all other powers of a Florida corporation not for profit.

5.2 Contracts. Any contract which is not to be fully performed within one (1) year from the making thereof, for the purchase, lease or renting of materials or equipment to be used by the Association in accomplishing its purposes, and all contracts for the provision of services, shall be in writing. Where a contract for purchase, lease or renting materials or equipment, or for the provision of services, requires payment by the Association on behalf of the Condominium in the aggregate exceeding \$5,000.00, the Association shall obtain competitive bids for the materials, equipment or services. Nothing contained herein shall be construed to require the Association to accept the lowest bid. Notwithstanding the foregoing, contracts with employees of the Association and contracts for attorney, accountant, architect, community association manager, engineering and

landscape architect services shall not be subject to the provisions hereof. Further, nothing contained herein is intended to limit the ability of the Association to obtain needed products and services in an emergency; nor shall the provisions hereof apply if the business entity with which the Association desires to contract is the only source of supply within the County.

6. Officers.

6.1 Executive Officers. The executive officers of the Association shall be a President, a Vice-President, a Treasurer and a Secretary (none of whom need be Directors), all of whom shall be elected by the Board of Directors and who may be peremptorily removed at any meeting by concurrence of a majority of all of the Directors. A person may hold more than one office, except that the President may not also be the Secretary. No person shall sign an instrument or perform an act in the capacity of more than one office. The Board of Directors from time to time shall elect such other officers and designate their powers and duties as the Board shall deem necessary or appropriate to manage the affairs of the Association. Officers, other than designees of the Developer, must be Unit Owners (or authorized representatives of corporate/partnership/trust Unit Owners).

6.2 President. The President shall be the chief executive officer of the Association. He shall have all of the powers and duties that are usually vested in the office of president of an association.

6.3 Vice-President. The Vice-President shall exercise the powers and perform the duties of the President in the absence or disability of the President. He also shall assist the President and exercise such other powers and perform such other duties as are incident to the office of the vice president of an association and as may be required by the Directors or the President.

6.4 Secretary. The Secretary shall keep the minutes of all proceedings of the Directors and the members. The Secretary shall attend to the giving of all notices to the members and Directors and other notices required by law. The Secretary shall have custody of the seal of the Association and shall affix it to instruments requiring the seal when duly signed. The Secretary shall keep the records of the Association, except those of the Treasurer, and shall perform all other duties incident to the office of the secretary of an association and as may be required by the Directors or the President.

6.5 Treasurer. The Treasurer shall have custody of all property of the Association, including funds, securities and evidences of indebtedness. The Treasurer shall keep books of account for the Association in accordance with good accounting practices, which, together with substantiating papers, shall be made available to the Board of Directors for examination at reasonable times. The Treasurer shall submit a treasurer's report to the Board of Directors at reasonable intervals and shall perform all other duties incident to the office of treasurer and as may be required by the Directors or the President. All monies and other valuable effects shall be kept for the benefit of the Association in such depositories as may be designated by a majority of the Board of Directors.

6.6 Developer Appointees. No officer appointed by the Developer may be removed except as provided in Section 4.15 hereof and by law.

7. Fiduciary Duty. The officers and Directors of the Association, as well as any manager employed by the Association, have a fiduciary relationship to the Unit Owners. No officer, Director or manager shall solicit, offer to accept, or accept any thing or service of value for which consideration has not been provided for his own benefit or that of his immediate family, from any person providing or proposing to provide goods or services to the Association. Any such officer, Director or manager who knowingly so solicits, offers to accept or accepts any thing or service of value shall, in addition to all other rights and remedies of the Association and Unit Owners, be subject to a civil penalty in accordance with the Act. Notwithstanding the foregoing, this paragraph shall not prohibit an officer, Director or manager from accepting services or items received in connection with trade fairs or education programs.

8. Compensation. Neither Directors nor officers shall receive compensation for their services as such, but this provision shall not preclude the Board of Directors from employing a Director or officer as an employee of the Association, nor preclude contracting with a Director or officer for the management of the Condominium or for any other service to be supplied by such Director or officer. Directors and officers shall be compensated for all actual and proper out of pocket expenses relating to the proper discharge of their respective duties.

9. Resignations. Any Director or officer may resign his post at any time by written resignation, delivered to the President or Secretary, which shall take effect upon its receipt unless a later date is specified in the resignation, in which event the resignation shall be effective from such date unless withdrawn. The acceptance of a resignation shall not be required to make it effective. The conveyance of all Units owned by

any Director or officer (other than appointees of the Developer or officers who were not Unit Owners) shall constitute a written resignation of such Director or officer.

10. Fiscal Management. The provisions for fiscal management of the Association set forth in the Declaration and Articles shall be supplemented by the following provisions:

10.1 Budget.

- (a) Adoption by Board; Items. The Board of Directors shall from time to time, and at least annually, prepare a budget for all Condominiums governed and operated by the Association (which shall detail all accounts and items of expense and contain at least all items set forth in Section 718.504(21) of the Act, if applicable), determine the amount of Assessments payable by the Unit Owners to meet the expenses of such Condominium(s) and allocate and assess such expenses among the Unit Owners in accordance with the provisions of the Declaration. In addition, if the Association maintains limited common elements with the cost to be shared only by those entitled to use the limited common elements, the budget or a schedule attached thereto shall show amounts budgeted therefor. In addition to annual operating expenses, the budget shall include reserve accounts for capital expenditures and deferred maintenance (to the extent required by law). These accounts shall include, but not be limited to, roof replacement, building painting and pavement resurfacing regardless of the amount of deferred maintenance expense or replacement cost, and for any other item for which the deferred maintenance expense or replacement cost exceeds \$10,000.00. The amount of reserves shall be computed by means of a formula which is based upon the estimated remaining useful life and the estimated replacement cost of each reserve item. The Association may adjust replacement and reserve assessments annually to take into account any changes in estimates or extension of the useful life of a reserve item caused by deferred maintenance. Reserves shall not be required if the members of the Association have, by a majority vote at a duly called meeting of members, determined for a specific fiscal year to provide no reserves or reserves less adequate than required hereby. Prior to transfer of control of the Association to Unit Owners other than the Developer, the Developer may vote to waive reserves or reduce the funding of reserves for the first two (2) fiscal years of operation of the Association, beginning with the fiscal year in which the Declaration is recorded, with the vote taken each fiscal year and to be effective for only one annual budget, after which time and until transfer of control of the Association to Unit Owners other than the Developer, reserves may only be waived or reduced upon the vote of a majority of all non-Developer voting interests voting in person or by limited proxy at a duly called meeting of the Association. Following transfer of control of the Association to Unit Owners other than the Developer, the Developer may vote its voting interest to waive or reduce the funding of reserves. If a meeting of Unit Owners has been called to determine to provide no reserves or reserves less adequate than required, and such result is not attained or a quorum is not attained, the reserves, as included in the budget, shall go into effect. Reserve funds and any interest accruing thereon shall remain in the reserve account or accounts, and shall be used only for authorized reserve expenditures, unless their use for any other purposes is approved in advance by a majority vote at a duly called meeting of the Association. Prior to transfer of control of the Association to Unit Owners other than the Developer, the Association shall not vote to use reserves for purposes other than that for which they were intended without the approval of a majority of all non-Developer voting interests, voting in person or by limited proxy at a duly called meeting of the Association.

The adoption of a budget for the Condominium shall comply with the requirements hereinafter set forth:

- (i) Notice of Meeting. A copy of the proposed budget of Common Expenses shall be hand delivered, mailed or electronically transmitted to each Unit Owner (at the address last furnished to the Association) not less than fourteen (14) days prior to the meeting of the Board of Directors at which the budget will be considered, together with a notice of that meeting indicating the time and place of such meeting. An officer or manager of the Association, or other person providing notice of such meeting, shall execute an affidavit evidencing compliance with such notice requirement and such affidavit shall be filed among the official records of the Association.
- (ii) Special Membership Meeting. If the Board of Directors adopts in any fiscal year an annual budget which requires assessments against Unit Owners which exceed one hundred fifteen percent (115%) of such Assessments for the preceding fiscal year, the Board of Directors shall conduct a special meeting of

the Unit Owners to consider a substitute budget if the Board of Directors receives, within twenty-one (21) days following the adoption of the annual budget, a written request for a special meeting from at least ten percent (10%) of all voting interests. The special meeting shall be conducted within sixty (60) days following the adoption of the annual budget. At least fourteen (14) days prior to such special meeting, the Board of Directors shall hand deliver to each Unit Owner, or mail to each Unit Owner at the address last furnished to the Association, a notice of the meeting. An officer or manager of the Association, or other person providing notice of such meeting, shall execute an affidavit evidencing compliance with this notice requirement and such affidavit shall be filed among the official records of the Association. Unit Owners may consider and adopt a substitute budget at the special meeting. A substitute budget is adopted if approved by a majority of all voting interests. If there is not a quorum at the special meeting or a substitute budget is not adopted, the annual budget previously adopted by the Board of Directors shall take effect as scheduled.

- (iii) Determination of Budget Amount. Any determination of whether assessments exceed one hundred fifteen percent (115%) of assessments for the preceding fiscal year shall exclude any authorized provision for reasonable reserves for repair or replacement of the Condominium Property, anticipated expenses of the Association which the Board of Directors does not expect to be incurred on a regular or annual basis, or assessments for betterments to the Condominium Property.
- (iv) Proviso. As long as the Developer is in control of the Board of Directors of the Association, the Board shall not impose Assessments for a year greater than one hundred fifteen percent (115%) of the prior fiscal year's Assessments, as herein defined, without the approval of a majority of all voting interests.

- (b) Adoption by Membership. In the event that the Board of Directors shall be unable to adopt a budget for a fiscal year in accordance with the requirements of Subsection 10.1(a) above, the Board of Directors may call a special meeting of Unit Owners for the purpose of considering and adopting such budget, which meeting shall be called and held in the manner provided for such special meetings in said subsection, or propose a budget in writing to the members, and if such budget is adopted by the members, upon ratification by a majority of the Board of Directors, it shall become the budget for such year.

10.2. Assessments. Assessments against Unit Owners for their share of the items of the budget shall be made for the applicable fiscal year annually at least twenty (20) days preceding the year for which the Assessments are made. Such Assessments shall be due in equal installments, payable in advance on the first day of each month (or each quarter at the election of the Board) of the year for which the Assessments are made. If annual Assessments are not made as required, Assessments shall be presumed to have been made in the amount of the last prior Assessments, and monthly (or quarterly) installments on such Assessments shall be due upon each installment payment date until changed by amended Assessments. In the event the annual Assessments prove to be insufficient, the budget and Assessments may be amended at any time by the Board of Directors, subject to the provisions of Section 10.1 hereof, if applicable. Unpaid Assessments for the remaining portion of the fiscal year for which amended Assessments are made shall be payable in as many equal installments as there are full months (or quarters) of the fiscal year left as of the date of such amended Assessments, each such monthly (or quarterly) installment to be paid on the first day of the month (or quarter), commencing the first day of the next ensuing month (or quarter). If only a partial month (or quarter) remains, the amended Assessments shall be paid with the next regular installment in the following year, unless otherwise directed by the Board in its resolution.

10.3 Special Assessments and Assessments for Capital Improvements. Special Assessments and Capital Improvement Assessments (as defined in the Declaration) shall be levied as provided in the Declaration and shall be paid in such manner as the Board of Directors of the Association may require in the notice of such Assessments. The funds collected pursuant to a Special Assessment shall be used only for the specific purpose or purposes set forth in the notice of adoption of same. However, upon completion of such specific purpose or purposes, any excess funds will be considered Common Surplus, and may, at the discretion of the Board, either be returned to the Unit Owners or applied as a credit towards future assessments.

10.4 Depository. The depository of the Association shall be such bank or banks in the State of Florida, which bank or banks must be insured by the FDIC, as shall be designated from time to time by the Directors and in which the monies of the Association shall be deposited. Withdrawal of monies from those accounts shall be made only by checks signed by such person or persons

as are authorized by the Directors. All sums collected by the Association from Assessments or otherwise may be commingled in a single fund or divided into more than one (1) fund, as determined by a majority of the Board of Directors. In addition, a separate reserve account should be established for the Association in such a depository for monies specifically designated as reserves for capital expenditures and/or deferred maintenance. Reserve and operating funds of the Association shall not be commingled unless combined for investment purposes, provided that the funds so commingled shall be accounted for separately and the combined account balance of such commingled funds may not, at any time, be less than the amount identified as reserve funds in the combined account.

- 10.5 Acceleration of Installments Upon Default. If a Unit Owner shall be in default in the payment of an installment upon his Assessments, the Board of Directors or its agent may accelerate the balance of the current budget years' Assessments upon thirty (30) days' prior written notice to the Unit Owner and the filing of a claim of lien, and the then unpaid balance of the current budget years' Assessments shall be due upon the date stated in the notice, but not less than five (5) days after delivery of the notice to the Unit Owner, or not less than ten (10) days after the mailing of such notice to him by certified mail, whichever shall first occur.
- 10.6 Fidelity Insurance or Fidelity Bonds. The Association shall obtain and maintain adequate insurance or fidelity bonding of all persons who control or disburse Association funds, which shall include, without limitation, those individuals authorized to sign Association checks and the president, secretary and treasurer of the Association. The insurance policy or fidelity bond shall be in such amount as shall be determined by a majority of the Board, but must be sufficient to cover the maximum funds that will be in the custody of the Association or its management agent at any one time. The premiums on such bonds and/or insurance shall be paid by the Association as a Common Expense.
- 10.7 Accounting Records and Reports. The Association shall maintain accounting records in the State, according to accounting practices normally used by similar associations. The records shall be open to inspection by Unit Owners or their authorized representatives at reasonable times and written summaries of them shall be supplied at least annually. The records shall include, but not be limited to, (a) a record of all receipts and expenditures, and (b) an account for each Unit designating the name and current mailing address of the Unit Owner, the amount of Assessments, the dates and amounts in which the Assessments come due, the amount paid upon the account and the dates so paid, and the balance due. Written summaries of the records described in clause (a) above, in the form and manner specified below, shall be supplied to each Unit Owner annually.

Within ninety (90) days following the end of the fiscal year, the Association shall prepare and complete, or contract for the preparation and completion of a financial report for the preceding fiscal year (the "Financial Report"). Within twenty-one (21) days after the final Financial Report is completed by the Association, or received from a third (3rd) party, but not later than one hundred twenty (120) days following the end of the fiscal year, the Board shall mail, or furnish by personal delivery, a copy of the Financial Report to each Unit Owner, or a notice that a copy of the Financial Report will be mailed or hand delivered to the Unit Owner, without charge, upon receipt of a written request from the Unit Owner.

The Financial Report shall be prepared in accordance with the rules adopted by the Division. The type of Financial Report to be prepared shall, unless modified in the manner set forth below, be based upon the Association's total annual revenues, as follows:

- (a) **REPORT OF CASH RECEIPTS AND EXPENDITURES** – if the Association's revenues are less than \$100,000.00 or if the Association operates less than fifty (50) Units (regardless of revenue) [or, if determined by the Board, the Association may prepare any of the reports described in subsections (b), (c) or (d) below in lieu of the report described in this section (a)].
- (b) **COMPILED FINANCIAL STATEMENTS** – if the Association's revenues are equal to or greater than \$100,000.00, but less than \$200,000.00 [or, if determined by the Board, the Association may prepare any of the reports described in subsections (c) or (d) below in lieu of the report described in this section (b)].
- (c) **REVIEWED FINANCIAL STATEMENTS** – if the Association's revenues are equal to or greater than \$200,000.00, but less than \$400,000.00 [or, if determined by the Board, the Association may prepare the report described in subsection (d) below in lieu of the report described in this section (c)].

- (d) AUDITED FINANCIAL STATEMENTS – if the Association's revenues are equal to or exceed \$400,000.00.

A report of cash receipts and expenditures must disclose the amount of receipts by accounts and receipt classifications and the amount of expenses by accounts and expense classifications, including, but not limited to, the following, as applicable: costs for security, professional and management fees and expenses, taxes, costs for recreation facilities, expenses for refuse collection and utility services, expenses for lawn care, costs for building maintenance and repair, insurance costs, administration and salary expenses, and reserves accumulated and expended for capital expenditures, deferred maintenance, and any other category for which the association maintains reserves.

If approved by a majority of the voting interests present at a properly called meeting of the Association, the Association may prepare or cause to be prepared: (i) a report of cash receipts and expenditures in lieu of a compiled, reviewed, or audited financial statement; (ii) a report of cash receipts and expenditures or a compiled financial statement in lieu of a reviewed or audited financial statement; or (iii) a report of cash receipts and expenditures, a compiled financial statement or a reviewed financial statement in lieu of an audited financial statement. Such meeting and approval must occur prior to the end of the fiscal year and is effective only for the fiscal year in which the vote is taken. Prior to the time that control of the Association has been turned over to Unit Owners other than the Developer, all Unit Owners, including the Developer, may vote on issues related to the preparation of financial reports for the first two (2) fiscal years of the Association's operation. Thereafter, until control of the Association has been turned over to Unit Owners other than the Developer, all Unit Owners except for the Developer may vote on such issues.

- 10.8 Application of Payment. All payments made by a Unit Owner shall be applied as provided in these By-Laws and in the Declaration or as otherwise determined by the Board.
- 10.9 Notice of Meetings. Notice of any meeting where Assessments against Unit Owners are to be considered for any reason shall specifically contain a statement that Assessments will be considered and the nature of any such Assessments.
11. Roster of Unit Owners. Each Unit Owner shall file with the Association a copy of the deed or other document showing his ownership. The Association shall maintain such information. The Association may rely upon the accuracy of such information for all purposes until notified in writing of changes therein as provided above. Only Unit Owners of record on the date notice of any meeting requiring their vote is given shall be entitled to notice of and to vote at such meeting, unless prior to such meeting other Owners shall produce adequate evidence, as provided above, of their interest and shall waive in writing notice of such meeting.
12. Parliamentary Rules. Except when specifically or impliedly waived by the chairman of a meeting (either of members or Directors), Robert's Rules of Order (latest edition) shall govern the conduct of the Association meetings when not in conflict with the Act, the Declaration, the Articles or these By-Laws; provided, however, that a strict or technical reading of said Robert's Rules shall not be made so as to frustrate the will of the persons properly participating in said meeting.
13. Amendments. Except as may be provided in the Declaration to the contrary, these By-Laws may be amended in the following manner:
- 13.1 Notice. Notice of the subject matter of a proposed amendment shall be included in the notice of a meeting at which a proposed amendment is to be considered.
- 13.2 Adoption. A resolution for the adoption of a proposed amendment may be proposed either by a majority of the Board of Directors or by not less than one-third (1/3) of the members of the Association. Directors and members not present in person or by proxy at the meeting considering the amendment may express their approval or disapproval in writing, provided that such approval or disapproval is delivered to the Secretary at or prior to the meeting. Such approval or disapproval may not be used as a vote for or against the action taken and may not be used for the purposes of creating a quorum. The proposed amendment must be approved:
- (a) by not less than a majority of the votes of all members of the Association voting in person or by proxy at a meeting at which a quorum has been attained and by not less than sixty-six and two thirds percent (66-2/3%) of the entire Board of Directors; or
- (b) after control of the Association has been turned over to Unit Owners other than the Developer, by not less than eighty percent (80%) of the votes of the members of the

Association voting in person or by proxy at a meeting at which a quorum has been attained.

- 13.3 Proviso. No amendment may be adopted which would eliminate, modify, prejudice, abridge or otherwise adversely affect any rights, benefits, privileges or priorities granted or reserved to the Developer or mortgagees of Units without the consent of said Developer and mortgagees in each instance. No amendment shall be made that is in conflict with the Articles or Declaration. No amendment to this Section shall be valid.
- 13.4 Execution and Recording. A copy of each amendment shall be attached to a certificate certifying that the amendment was duly adopted as an amendment of these By-Laws, which certificate shall be executed by the President or Vice-President and attested by the Secretary or Assistant Secretary of the Association with the formalities of a deed, or by the Developer alone if the amendment has been adopted consistent with the provisions of the Declaration allowing such action by the Developer. The amendment shall be effective when the certificate and a copy of the amendment is recorded in the Public Records of the County with an identification on the first page of the amendment of the Official Records Book and Page of said Public Records where the Declaration is recorded.
14. Rules and Regulations. The Board of Directors may, from time to time, adopt and thereafter modify, amend or add to adopted rules and regulations, except that subsequent to the date control of the Board is turned over by the Developer to Unit Owners other than the Developer, Owners of a majority of the Units may overrule the Board with respect to any adopted rules or such modifications, amendments or additions. Copies of any such adopted, modified, amended or additional rules and regulations shall be furnished by the Board of Directors to each affected Unit Owner not less than thirty (30) days prior to the effective date thereof. At no time may any rule or regulation be adopted which would prejudice the rights reserved to the Developer or the Hotel Unit Owner.
15. Written Inquiries. When a Unit Owner files a written inquiry by certified mail with the Board, the Board shall respond in writing to the Unit Owner within thirty (30) days of receipt of such inquiry and more particularly in the manner set forth in Section 718.112(2)(a)2, Florida Statutes. The Association may, through its Board, adopt reasonable rules and regulations regarding the frequency and manner of responding to Unit Owner inquiries.
16. Official Records. From the inception of the Association, the Association shall maintain for the condominium, a copy of each of the following, where applicable, which shall constitute the official records of the Association:
- (a) The plans, permits, warranties, and other items provided by the Developer pursuant to Section 718.301(4) of the Act;
 - (b) A photocopy of the recorded Declaration of Condominium and all amendments thereto;
 - (c) A photocopy of the recorded By-Laws of the Association and all amendments thereto;
 - (d) A certified copy of the Articles of Incorporation of the Association or other documents creating the Association and all amendments thereto;
 - (e) A copy of the current Rules and Regulations of the Association;
 - (f) A book or books containing the minutes of all meetings of the Association, of the Board of Directors, and of Unit Owners, which minutes shall be retained for a period of not less than 7 years;
 - (g) A current roster of all Unit Owners, their mailing addresses, Unit identifications, voting certifications, and if known, telephone numbers. The Association shall also maintain the electronic mailing addresses and the numbers designated by Unit Owners for receiving notices sent by electronic transmission of those Unit Owners consenting to receive notice by electronic transmission. The electronic mailing addresses and numbers provided by Unit Owners to receive notice by electronic transmission shall be removed from Association records when consent to receive notice by electronic transmission is revoked. However, the Association shall not be liable for an erroneous disclosure of the electronic mail address or the number for receiving electronic transmission of notices;
 - (h) All current insurance policies of the Association and of all Condominiums operated by the Association;
 - (i) A current copy of any management agreement, lease, or other contract to which the Association is a party or under which the Association or the Unit Owners have an obligation or responsibility;

- (j) Bills of Sale or transfer for all property owned by the Association;
- (k) Accounting records for the Association and the accounting records for the Condominium. All accounting records shall be maintained for a period of not less than seven (7) years. The accounting records shall include, but not be limited to:
 - (i) Accurate, itemized, and detailed records for all receipts and expenditures.
 - (ii) A current account and a monthly, bimonthly, or quarterly statement of the account for each Unit designating the name of the Unit Owner, the due date and amount of each Assessment, the amount paid upon the account, and the balance due.
 - (iii) All audits, reviews, accounting statements, and financial reports of the Association or Condominium.
 - (iv) All contracts for work to be performed. Bids for work to be performed shall also be considered official records and shall be maintained for a period of one (1) year;
- (l) Ballots, sign-in sheets, voting proxies and all other papers relating to elections which shall be maintained for a period of one (1) year from the date of the meeting to which the document relates;
- (m) All rental records where the Association is acting as agent for the rental of Units;
- (n) A copy of the current Question and Answer Sheet, in the form promulgated by the Division, which shall be updated annually; and
- (o) All other records of the Association not specifically listed above which are related to the operation of the Association.

The official records of the Association shall be maintained in the County in which the Condominium is located, or if in another county, then within twenty five (25) miles of the Condominium. The official records of the Association shall be open to inspection by any Association member or the authorized representative of such member and shall be made available to a Unit Owner within five (5) working days after receipt of a written request by the Board or its designee. The right to inspect the records includes the right to make or obtain copies, at a reasonable expense, if any, of the Association member. The Association may adopt reasonable rules regarding the time, location, notice and manner of record inspections and copying. The failure of an Association to provide official records to a Unit Owner or his authorized representative within ten (10) working days after receipt of a written request therefor shall create a rebuttable presumption that the Association willfully failed to comply with this paragraph. Failure to permit inspection of the Association records as provided herein entitles any person prevailing in an enforcement action to recover reasonable attorneys' fees from the person in control of the records who, directly or indirectly, knowingly denies access to the records for inspection. The Association shall maintain on the Condominium Property an adequate number of copies of the Declaration, Articles, By-Laws and rules, and all amendments to the foregoing, as well as the Question and Answer Sheet and year-end financial information required by the Act, to ensure their availability to Unit Owners and prospective purchasers. The Association may charge its actual costs for preparing and furnishing these documents to those persons requesting same. Notwithstanding the provisions of this Section 16, the following records shall not be accessible to Unit Owners:

- (i) Any record protected by the lawyer-client privilege as described in Section 90.502, Florida Statutes, and any record protected by the work-product privilege including any record prepared by an Association attorney or prepared at the attorney's express direction, which reflects a mental impression, conclusion, litigation strategy, or legal theory of the attorney or the Association, and which was prepared exclusively for civil or criminal litigation or for adversarial administrative proceedings, or which was prepared in anticipation or imminent civil or criminal litigation or imminent adversarial administrative proceedings until the conclusion of the litigation or adversarial administrative proceedings.
 - (ii) Information obtained by an Association in connection with the approval of the lease, sale or other transfer of a Unit.
 - (iii) Medical records of Unit Owners.
17. Certificate of Compliance. A certificate of compliance from a licensed electrical contractor or electrician may be accepted by the Association's Board as evidence of compliance of the Units to the applicable condominium fire and life safety code.
18. Provision of Information to Purchasers or Lienholders. The Association or its authorized agent shall not be required to provide a prospective purchaser or lienholder with information about the Condominium or the

Association other than information or documents required by the Act to be made available or disclosed. The Association or its authorized agent shall be entitled to charge a reasonable fee to the prospective purchaser, lienholder, or the current Unit Owner for its time in providing good faith responses to requests for information by or on behalf of a prospective purchaser or lienholder, other than that required by law, provided that such fee shall not exceed \$150.00 plus the reasonable cost of photocopying and any attorney's fees incurred by the Association in connection with the Association's response.

19. Electronic Transmission. For purposes hereof, "electronic transmission" means any form of communication, not directly involving the physical transmission or transfer of paper, which creates a record that may be retained, retrieved, and reviewed by a recipient thereof and which may be directly reproduced in a comprehensible and legible paper form by such recipient through an automated process. Examples of electronic transmission include, but are not limited to, telegrams, facsimile transmissions of images, and text that is sent via electronic mail between computers. Notwithstanding the provision for electronic transmission of notices by the Association, same may be only be sent to Unit Owners that consent to receipt of Association notices by electronic transmission (and only for long as such consent remains in effect). Further, in no event may electronic transmission be used as a method of giving notice of a meeting called in whole or in part regarding the recall of a Director.
20. Construction. Wherever the context so permits, the singular shall include the plural, the plural shall include the singular, and the use of any gender shall be deemed to include all genders. To the extent not otherwise provided for or addressed in these By-Laws, the By-Laws shall be deemed to include the provisions of Section 718.112(2)(a) through (m) of the Act.
21. Captions. The captions herein are inserted only as a matter of convenience and for reference, and in no way define or limit the scope of these By-Laws or the intent of any provision hereof.

The foregoing was adopted as the By-Laws of FONTAINEBLEAU III OCEAN CLUB CONDOMINIUM ASSOCIATION, INC., a corporation not for profit under the laws of the State of Florida, as of the ____ day of _____, 200__.

Approved:

, President

, Secretary

Exhibit "5"

ARTICLES OF INCORPORATION
FOR
FONTAINEBLEAU III OCEAN CLUB CONDOMINIUM ASSOCIATION, INC.

The undersigned incorporator, for the purpose of forming a corporation not for profit pursuant to the laws of the State of Florida, hereby adopts the following Articles of Incorporation:

ARTICLE 1
NAME

The name of the corporation shall be FONTAINEBLEAU III OCEAN CLUB CONDOMINIUM ASSOCIATION, INC. For convenience, the corporation shall be referred to in this instrument as the "Association", these Articles of Incorporation as the "Articles", and the By-Laws of the Association as the "By-Laws".

ARTICLE 2
OFFICE

The principal office and mailing address of the Association shall be at 19501 Biscayne Boulevard, Suite 400, Aventura Florida 33180, or at such other place as may be subsequently designated by the Board of Directors. All books and records of the Association shall be kept at its principal office or at such other place as may be permitted by the Act.

ARTICLE 3
PURPOSE

The purpose for which the Association is organized is to provide an entity pursuant to the Florida Condominium Act as it exists on the date hereof (the "Act") for the operation of that certain condominium located in Miami-Dade County, Florida, and known as FONTAINEBLEAU III OCEAN CLUB CONDOMINIUM (the "Condominium").

ARTICLE 4
DEFINITIONS

The terms used in these Articles shall have the same definitions and meanings as those set forth in the Declaration of the Condominium to be recorded in the Public Records of Miami-Dade County, Florida, unless herein provided to the contrary, or unless the context otherwise requires.

ARTICLE 5
POWERS

The powers of the Association shall include and be governed by the following:

- 5.1 General. The Association shall have all of the common-law and statutory powers of a corporation not for profit under the Laws of Florida, except as expressly limited or restricted by the terms of these Articles, the Declaration, the By-Laws or the Act.
- 5.2 Enumeration. The Association shall have all of the powers and duties set forth in the Act, except as limited by these Articles, the By-Laws and the Declaration (to the extent that they are not in conflict with the Act), and all of the powers and duties reasonably necessary to operate the Condominium pursuant to the Declaration and as more particularly described in the By-Laws, as they may be amended from time to time, including, but not limited to, the following:

- (a) To make and collect Assessments and other charges against members as Unit Owners (whether or not such sums are due and payable to the Association), and to use the proceeds thereof in the exercise of its powers and duties.
 - (b) To buy, accept, own, operate, lease, sell, trade and mortgage both real and personal property in accordance with the provisions of the Declaration.
 - (c) To maintain, repair, replace, reconstruct, add to and operate the Common Elements and/or Association Property, and other property acquired or leased by the Association.
 - (d) To purchase insurance upon the Common Elements and Association Property and insurance for the protection of the Association, its officers, Directors and Unit Owners.
 - (e) To make and amend reasonable rules and regulations for the maintenance, conservation and use of the Common Elements and Association Property and for the health, comfort, safety and welfare of the Unit Owners.
 - (f) To enforce by legal means the provisions of the Act, the Declaration, these Articles, the By-Laws, and the rules and regulations for the use of the Common Elements and Association Property.
 - (g) To contract for the management and maintenance of the Common Elements and/or Association Property and to authorize a management agent (which may be an affiliate of the Developer) to assist the Association in carrying out its powers and duties by performing such functions as the submission of proposals, collection of Assessments, preparation of records, enforcement of rules and maintenance, repair and replacement of the Common Elements and Association Property with such funds as shall be made available by the Association for such purposes. The Association and its officers shall, however, retain at all times the powers and duties granted by the Condominium Act, including, but not limited to, the making of Assessments, promulgation of rules and execution of contracts on behalf of the Association.
 - (h) To employ personnel to perform the services required for the proper operation of the Common Elements and the Association Property.
- 5.3 Association Property. All funds and the title to all properties acquired by the Association and their proceeds shall be held for the benefit and use of the members in accordance with the provisions of the Declaration, these Articles and the By-Laws.
- 5.4 Distribution of Income; Dissolution. The Association shall not pay a dividend to its members and shall make no distribution of income to its members, Directors or officers, and upon dissolution, all assets of the Association shall be transferred only to another non-profit corporation or a public agency or as otherwise authorized by the Florida Not For Profit Corporation Act (Chapter 617, Florida Statutes).
- 5.5 Limitation. The powers of the Association shall be subject to and shall be exercised in accordance with the provisions hereof and of the Declaration, the By-Laws and the Act, provided that in the event of conflict, the provisions of the Act shall control over those of the Declaration and By-Laws.

ARTICLE 6
MEMBERS

- 6.1 **Membership.** The members of the Association shall consist of all of the record title Owners of Units in the Condominium from time to time, and after termination of the Condominium, shall also consist of those who were members at the time of such termination, and their successors and assigns.
- 6.2 **Assignment.** The share of a member in the funds and assets of the Association cannot be assigned, hypothecated or transferred in any manner except as an appurtenance to the Unit for which that share is held.
- 6.3 **Voting.** On all matters upon which the membership shall be entitled to vote, there shall be only one (1) vote for each Residential Unit. The Hotel Unit shall be entitled to cast one hundred twenty five (125) votes. All votes shall be exercised or cast in the manner provided by the Declaration and By-Laws. Any person or entity owning more than one (1) Unit shall be entitled to cast the aggregate number of votes attributable to all Units owned.
- 6.4 **Meetings.** The By-Laws shall provide for an annual meeting of members, and may make provision for regular and special meetings of members other than the annual meeting.

ARTICLE 7
INCORPORATOR

The name and address of the Incorporator of this Corporation is:

<u>NAME</u>	<u>ADDRESS</u>
Robert Vollrath	19501 Biscayne Boulevard, Suite 400 Aventura, Florida 33180

ARTICLE 8
TERM OF EXISTENCE

The Association shall have perpetual existence, unless dissolved in accordance with applicable law.

ARTICLE 9
OFFICERS

The affairs of the Association shall be administered by the officers holding the offices designated in the By-Laws. The officers shall be elected by the Board of Directors of the Association at its first meeting following the annual meeting of the members of the Association and shall serve at the pleasure of the Board of Directors. The By-Laws may provide for the removal from office of officers, for filling vacancies and for the duties and qualifications of the officers.

The names and addresses of the officers who shall serve until their successors are designated by the Board of Directors are as follows:

President:

Michael Gilbert

19501 Biscayne Boulevard, Suite 400
Aventura, Florida 33180

Vice President:

Melanie Muss

19501 Biscayne Boulevard, Suite 400
Aventura, Florida 33180

Secretary/Treasurer

Robert Vollrath

19501 Biscayne Boulevard, Suite 400
Aventura, Florida 33180

ARTICLE 10
DIRECTORS

- 10.1 Number and Qualification. The property, business and affairs of the Association shall be managed by a Board consisting of the number of Directors determined in the manner provided by the By-Laws, but which shall consist of not less than three (3) Directors, nor more than nine (9) Directors. Directors need not be members of the Association.
- 10.2 Duties and Powers. All of the duties and powers of the Association existing under the Act, the Declaration, these Articles and the By-Laws shall be exercised exclusively by the Board of Directors, its agents, contractors or employees, subject only to approval by Unit Owners when such approval is specifically required.
- 10.3 Election; Removal. Directors of the Association shall be elected at the annual meeting of the members in the manner determined by and subject to the qualifications set forth in the By-Laws. Directors may be removed and vacancies on the Board of Directors shall be filled in the manner provided by the By-Laws.
- 10.4 Term of Developer's Directors. The Developer of the Condominium shall appoint the members of the first Board of Directors and their replacements who shall hold office for the periods described in the By-Laws.
- 10.5 First Directors. The names and addresses of the members of the first Board of Directors who shall hold office until their successors are elected and have taken office, as provided in the By-Laws, are as follows:

<u>NAME</u>	<u>ADDRESS</u>
Mario Romine	19501 Biscayne Boulevard, Suite 400 Aventura, Florida 33180
Bruce Weiner	19501 Biscayne Boulevard, Suite 400 Aventura, Florida 33180
Dar Gennett	19501 Biscayne Boulevard, Suite 400 Aventura, Florida 33180

- 10.6 Standards. A Director shall discharge his or her duties as a Director, including any duties as a member of a Committee: in good faith; with the care an ordinary prudent person in a like position would exercise under similar circumstances; and in a manner reasonably believed to be in the best interests of the Association. Unless a Director has knowledge concerning a matter in question that makes reliance unwarranted, a Director, in discharging his or her duties, may rely on information, opinions, reports or statements, including financial statements and other data, if prepared or presented by: one or more officers or employees of the Association whom the Director reasonably believes to be reasonable and competent in the manners presented; legal counsel, public accountants or other persons as to matters the Director reasonably believes are within the persons' professional or expert competence; or a Committee of which the Director is not a member if the Director reasonably believes the Committee merits confidence. A Director is not liable for any action taken as a Director, or any failure to take action, if he performed the duties of his or her office in compliance with the foregoing standards.

ARTICLE 11
INDEMNIFICATION PROVISIONS

- 11.1 Indemnitees. The Association shall indemnify any person who was or is a party to any proceeding (other than an action by, or in the right of, the Association) by reason of the fact that he or she is or was a Director, officer, employee or agent (each, an "Indemnitee") of the Association, against liability incurred in connection with such proceeding, including any appeal thereof, if he or she acted in good faith and in a manner he or she reasonably believed to be in, or not opposed to, the best interests of the Association and, with respect to any criminal action or proceeding, had no reasonable cause to believe his or her conduct was unlawful. The termination of any proceeding by judgment, order, settlement, or conviction or upon a plea of nolo contendere or its equivalent shall not, of itself, create a presumption that the person did not act in good faith and in a manner which he reasonably believed to be in, or not opposed to, the best interests of the Association or, with respect to any criminal action or proceeding, had reasonable cause to believe that his or her conduct was unlawful.
- 11.2 Indemnification. The Association shall indemnify any person, who was or is a party to any proceeding by or in the right of the Association to procure a judgment in its favor by reason of the fact that he or she is or was a Director, officer, employee, or agent of the Association against expenses and amounts paid in settlement not exceeding, in the judgment of the Board of Directors, the estimated expense of litigating the proceeding to conclusion, actually and reasonably incurred in connection with the defense or settlement of such proceeding, including any appeal thereof. Such indemnification shall be authorized if such person acted in good faith and in a manner he

reasonably believed to be in, or not opposed to, the best interests of the Association, except that no indemnification shall be made under this Article 11 in respect of any claim, issue, or matter as to which such person shall have been adjudged to be liable unless, and only to the extent that, the court in which such proceeding was brought, or any other court of competent jurisdiction, shall determine upon application that, despite the adjudication of liability but in view of all circumstances of the case, such person is fairly and reasonably entitled to indemnity for such expenses which such court shall deem proper.

- 11.3 Indemnification for Expenses. To the extent that a Director, officer, employee, or agent of the Association has been successful on the merits or otherwise in defense of any proceeding referred to in subsection 11.1 or 11.2, or in defense of any claim, issue, or matter therein, he or she shall be indemnified against expenses actually and reasonably incurred by him or her in connection therewith.
- 11.4 Determination of Applicability. Any indemnification under subsection 11.1 or subsection 11.2, unless pursuant to a determination by a court, shall be made by the Association only as authorized in the specific case upon a determination that indemnification of the Director, officer, employee, or agent is proper under the circumstances because he or she has met the applicable standard of conduct set forth in subsection 11.1 or subsection 11.2. Such determination shall be made:
- (a) By the Board of Directors by a majority vote of a quorum consisting of Directors who were not parties to such proceeding;
 - (b) If such a quorum is not obtainable or, even if obtainable, by majority vote of a Committee duly designated by the Board of Directors (in which Directors who are parties may participate) consisting solely of two (2) or more Directors not at the time parties to the proceeding;
 - (c) By independent legal counsel:
 - 1. selected by the Board of Directors prescribed in paragraph 11.4(a) or the Committee prescribed in paragraph 11.4(b); or
 - 2. if a quorum of the Directors cannot be obtained for paragraph 11.4(a) and the Committee cannot be designated under paragraph 11.4(b), selected by majority vote of the full Board of Directors (in which Directors who are parties may participate); or
 - (d) By a majority of the voting interests of the members of the Association who were not parties to such proceeding.
- 11.5 Determination Regarding Expenses. Evaluation of the reasonableness of expenses and authorization of indemnification shall be made in the same manner as the determination that indemnification is permissible. However, if the determination of permissibility is made by independent legal counsel, persons specified by paragraph 11.4(c) shall evaluate the reasonableness of expenses and may authorize indemnification.
- 11.6 Advancing Expenses. Expenses incurred by an officer or Director in defending a civil or criminal proceeding may be paid by the Association in advance of the final disposition of such proceeding upon receipt of an undertaking by or on behalf of such Director or officer to repay such amount if he is ultimately found not to be entitled to indemnification by the Association pursuant to this

section. Expenses incurred by other employees and agents may be paid in advance upon such terms or conditions that the Board of Directors deems appropriate.

- 11.7 Exclusivity; Exclusions. The indemnification and advancement of expenses provided pursuant to this section are not exclusive, and the Association may make any other or further indemnification or advancement of expenses of any of its Directors, officers, employees, or agents, under any bylaw, agreement, vote of shareholders or disinterested Directors, or otherwise, both as to action in his or her official capacity and as to action in another capacity while holding such office. However, indemnification or advancement of expenses shall not be made to or on behalf of any Director, officer, employee, or agent if a judgment or other final adjudication establishes that his or her actions, or omissions to act, were material to the cause of action so adjudicated and constitute:
- (a) A violation of the criminal law, unless the Director, officer, employee, or agent had reasonable cause to believe his or her conduct was lawful or had no reasonable cause to believe his or her conduct was unlawful;
 - (b) A transaction from which the Director, officer, employee, or agent derived an improper personal benefit; or
 - (c) Willful misconduct or a conscious disregard for the best interests of the Association in a proceeding by or in the right of the Association to procure a judgment in its favor or in a proceeding by or in the right of the members of the Association.
- 11.8 Continuing Effect. Indemnification and advancement of expenses as provided in this Article 11 shall continue as, unless otherwise provided when authorized or ratified, to a person who has ceased to be a Director, officer, employee, or agent and shall inure to the benefit of the heirs, executors, and administrators of such a person, unless otherwise provided when authorized or ratified.
- 11.9 Application to Court. Notwithstanding the failure of the Association to provide indemnification, and despite any contrary determination of the Board or of the members in the specific case, a Director, officer, employee, or agent of the Association who is or was a party to a proceeding may apply for indemnification or advancement of expenses, or both, to the court conducting the proceeding, to the circuit court, or to another court of competent jurisdiction. On receipt of an application, the court, after giving any notice that it considers necessary, may order indemnification and advancement of expenses, including expenses incurred in seeking court-ordered indemnification or advancement of expenses, if it determines that:
- (a) The Director, officer, employee, or agent is entitled to mandatory indemnification under subsection 11.3, in which case the court shall also order the Association to pay the Director reasonable expenses incurred in obtaining court-ordered indemnification or advancement of expenses;
 - (b) The Director, officer, employee, or agent is entitled to indemnification or advancement of expenses, or both, by virtue of the exercise by the Association of its power pursuant to subsection 11.7; or
 - (c) The Director, officer, employee, or agent is fairly and reasonably entitled to indemnification or advancement of expenses, or both, in view of all the relevant circumstances, regardless of whether such person met the standard of conduct set forth in subsection 11.1, subsection 11.2, or subsection 11.7 unless (a) a court of competent jurisdiction determines, after all available appeals have been exhausted or not pursued by

the proposed indemnitee, that he or she did not act in good faith or acted in a manner he or she reasonably believed to be not in, or opposed to, the best interest of the Association, and, with respect to any criminal action or proceeding, that he or she had reasonable cause to believe his or her conduct was unlawful, and (b) such court further specifically determines that indemnification should be denied. The termination of any proceeding by judgment, order, settlement, conviction or upon a plea of nolo contendere or its equivalent shall not, of itself, create a presumption that the person did not act in good faith or did act in a manner which he or she reasonably believed to be not in, or opposed to, the best interest of the Association, and, with respect to any criminal action or proceeding, that he or she had reasonable cause to believe that his or her conduct was unlawful.

- 11.10 Definitions. For purposes of this Article 11, the term "expenses" shall be deemed to include attorneys' fees and related "out-of-pocket" expenses, including those for any appeals; the term "liability" shall be deemed to include obligations to pay a judgment, settlement, penalty, fine, and expenses actually and reasonably incurred with respect to a proceeding; the term "proceeding" shall be deemed to include any threatened, pending, or completed action, suit, or other type of proceeding, whether civil, criminal, administrative or investigative, and whether formal or informal; and the term "agent" shall be deemed to include a volunteer; the term "serving at the request of the Association" shall be deemed to include any service as a Director, officer, employee or agent of the Association that imposes duties on, and which are accepted by, such persons.
- 11.11 Effect. The indemnification provided by this Article 11 shall not be deemed exclusive of any other rights to which those seeking indemnification may be entitled under any applicable law, agreement, vote of members or otherwise.
- 11.12 Amendment. Anything to the contrary herein notwithstanding, no amendment to the provisions of this Article 11 shall be applicable as to any party eligible for indemnification hereunder who has not given his or her prior written consent to such amendment.

ARTICLE 12 BY-LAWS

The first By-Laws of the Association shall be adopted by the Board of Directors and may be altered, amended or rescinded in the manner provided in the By-Laws and the Declaration.

ARTICLE 13 AMENDMENTS

Amendments to these Articles shall be proposed and adopted in the following manner:

- 13.1 Notice. Notice of a proposed amendment shall be included in the notice of any meeting at which the proposed amendment is to be considered and shall be otherwise given in the time and manner provided in Chapter 617, Florida Statutes. Such notice shall contain the proposed amendment or a summary of the changes to be affected thereby.
- 13.2 Adoption. Amendments shall be proposed and adopted in the manner provided in Chapter 617, Florida Statutes and in the Act (the latter to control over the former to the extent provided for in the Act).
- 13.3 Limitation. No amendment shall make any changes in the qualifications for membership, nor in the voting rights or property rights of members, nor any changes in Subsections 5.3, 5.4 or 5.5, without

the approval in writing of all members and the joinder of all record owners of mortgages upon Units. No amendment shall be made that is in conflict with the Act, the Declaration or the By-Laws, nor shall any amendment make any changes which would in any way affect any of the rights, privileges, powers or options herein provided in favor of or reserved to the Developer and/or Institutional First Mortgagees, unless the Developer and/or the Institutional First Mortgagees, as applicable, shall join in the execution of the amendment. No amendment to this paragraph 13.3 shall be effective.

- 13.4 Developer Amendments. Notwithstanding anything herein contained to the contrary, to the extent lawful, the Developer may amend these Articles consistent with the provisions of the Declaration allowing certain amendments to be effected by the Developer alone.
- 13.5 Recording. A copy of each amendment shall be filed with the Secretary of State pursuant to the provisions of applicable Florida law, and a copy certified by the Secretary of State shall be recorded in the public records of Miami-Dade County, Florida with an identification on the first page thereof of the book and page of said public records where the Declaration was recorded which contains, as an exhibit, the initial recording of these Articles.

ARTICLE 14
INITIAL REGISTERED OFFICE;
ADDRESS AND NAME OF REGISTERED AGENT

The initial registered office of this corporation shall be at 19501 Biscayne Boulevard, Suite 400, Aventura, Florida 33180, with the privilege of having its office and branch offices at other places within or without the State of Florida. The initial registered agent at that address shall be Mario Romine.

IN WITNESS WHEREOF, the Incorporator has affixed his signature this ____ day of _____, 200__.

Robert Vollrath, Incorporator

CERTIFICATE DESIGNATING PLACE OF BUSINESS OR DOMICILE FOR THE SERVICE OF PROCESS WITHIN THIS STATE, NAMING AGENT UPON WHOM PROCESS MAY BE SERVED.

In compliance with the laws of Florida, the following is submitted:

First -- That desiring to organize under the laws of the State of Florida with its principal office, as indicated in the foregoing articles of incorporation, in the County of Miami-Dade, State of Florida, the Association named in the said articles has named Mario Romine, located at 19501 Biscayne Boulevard, Suite 400, Aventura, Florida 33180, as its statutory registered agent.

Having been named the statutory agent of said Association at the place designated in this certificate, I am familiar with the obligations of that position, and hereby accept the same and agree to act in this capacity, and agree to comply with the provisions of Florida law relative to keeping the registered office open.

Mario Romine, Registered Agent

DATED this ___ day of _____, 200__.

Exhibit "6"
Guaranteed Assessments

Floor	Unit Type	Annual	Quarterly	Monthly
301	D2	\$ 847.63	\$ 211.91	\$ 70.64
302	D	737.18	184.30	61.43
303	D	737.18	184.30	61.43
304	D	737.18	184.30	61.43
305	D	737.18	184.30	61.43
306	D	737.18	184.30	61.43
307	D1	1,298.41	324.60	108.20
309	J	1,049.26	262.32	87.44
310	H	1,496.19	374.05	124.68
311	G	707.64	176.91	58.97
312	G	707.64	176.91	58.97
313	G	707.64	176.91	58.97
314	G	707.64	176.91	58.97
315	G	707.64	176.91	58.97
316	I	1,424.27	356.07	118.69
317	G	707.64	176.91	58.97
318	G2	1,018.43	254.61	84.87
319	N	839.92	209.98	69.99
320	M	797.54	199.39	66.46
401	D2	847.63	211.91	70.64
402	D	737.18	184.30	61.43
403	D	737.18	184.30	61.43
404	D	737.18	184.30	61.43
405	D	737.18	184.30	61.43
406	D	737.18	184.30	61.43
407	D1	1,298.41	324.60	108.20
409	J	1,049.26	262.32	87.44
410	H	1,496.19	374.05	124.68
411	G	707.64	176.91	58.97
412	G	707.64	176.91	58.97
413	G	707.64	176.91	58.97
414	G	707.64	176.91	58.97
415	G	707.64	176.91	58.97
416	I	1,424.27	356.07	118.69
417	G	707.64	176.91	58.97
418	G2	1,018.43	254.61	84.87
419	N	839.92	209.98	69.99
420	M	797.54	199.39	66.46
501	D2	847.63	211.91	70.64
502	D	737.18	184.30	61.43
503	D	737.18	184.30	61.43
504	D	737.18	184.30	61.43
505	D	737.18	184.30	61.43
506	D	737.18	184.30	61.43
507	D1	1,298.41	324.60	108.20
509	A	1,044.12	261.03	87.01
510	E2	706.35	176.59	58.86
511	E	706.35	176.59	58.86
512	TS	7,298.67	1,824.64	608.21
520	K2	751.30	187.83	62.61
521	K	796.25	199.06	66.35
522	K	796.25	199.06	66.35
523	L	1,440.96	360.24	120.08
601	D2	847.63	211.91	70.64
602	D	737.18	184.30	61.43
603	D	737.18	184.30	61.43
604	D	737.18	184.30	61.43
605	D	737.18	184.30	61.43
606	D	737.18	184.30	61.43
607	D1	1,298.41	324.60	108.20
609	A	1,044.12	261.03	87.01
610	E2	706.35	176.59	58.86
616	F	729.47	182.37	60.79

Floor	Unit Type	Annual	Quarterly	Monthly
617	F2	729.47	182.37	60.79
618	F	729.47	182.37	60.79
619	C1	1,116.04	279.01	93.00
620	K2	751.30	187.83	62.61
621	K	796.25	199.06	66.35
622	K	796.25	199.06	66.35
623	L	1,440.96	360.24	120.08
701	D2	847.63	211.91	70.64
702	D	737.18	184.30	61.43
703	D	737.18	184.30	61.43
704	D	737.18	184.30	61.43
705	D	737.18	184.30	61.43
706	D	737.18	184.30	61.43
707	D1	1,298.41	324.60	108.20
709	A	1,044.12	261.03	87.01
710	E2	706.35	176.59	58.86
711	E	706.35	176.59	58.86
712	E	706.35	176.59	58.86
713	E2	706.35	176.59	58.86
714	B	1,274.01	318.50	106.17
715	Fa	706.35	176.59	58.86
716	F	729.47	182.37	60.79
717	F2	729.47	182.37	60.79
718	F	729.47	182.37	60.79
719	C1	1,116.04	279.01	93.00
720	K2	751.30	187.83	62.61
721	K	796.25	199.06	66.35
722	K	796.25	199.06	66.35
723	L	1,440.96	360.24	120.08
801	Db	778.27	194.57	64.86
802	D	737.18	184.30	61.43
803	D	737.18	184.30	61.43
804	D	737.18	184.30	61.43
805	D	737.18	184.30	61.43
806	D	737.18	184.30	61.43
807	D1	1,298.41	324.60	108.20
809	A	1,044.12	261.03	87.01
810	E2	706.35	176.59	58.86
811	E	706.35	176.59	58.86
812	E	706.35	176.59	58.86
813	E2	706.35	176.59	58.86
814	B	1,274.01	318.50	106.17
815	Fa	706.35	176.59	58.86
816	F	729.47	182.37	60.79
817	F2	729.47	182.37	60.79
818	F	729.47	182.37	60.79
819	C1	1,116.04	279.01	93.00
901	Db	778.27	194.57	64.86
902	D	737.18	184.30	61.43
903	D	737.18	184.30	61.43
904	D	737.18	184.30	61.43
905	D	737.18	184.30	61.43
906	D	737.18	184.30	61.43
907	D1	1,298.41	324.60	108.20
909	A	1,044.12	261.03	87.01
910	E2	706.35	176.59	58.86
911	E	706.35	176.59	58.86
912	E	706.35	176.59	58.86
913	E2	706.35	176.59	58.86
914	B	1,274.01	318.50	106.17
915	Fa	706.35	176.59	58.86
916	F	729.47	182.37	60.79
917	F2	729.47	182.37	60.79

Floor	Unit Type	Annual	Quarterly	Monthly
918	F	729.47	182.37	60.79
919	C2	1,086.50	271.63	90.54
1001	Db	778.27	194.57	64.86
1002	D	737.18	184.30	61.43
1003	D	737.18	184.30	61.43
1004	D	737.18	184.30	61.43
1005	D	737.18	184.30	61.43
1006	D	737.18	184.30	61.43
1007	D1	1,298.41	324.60	108.20
1009	A	1,044.12	261.03	87.01
1010	E2	706.35	176.59	58.86
1011	E	706.35	176.59	58.86
1012	E	706.35	176.59	58.86
1013	E2	706.35	176.59	58.86
1014	B	1,274.01	318.50	106.17
1015	Fa	706.35	176.59	58.86
1016	F	729.47	182.37	60.79
1017	F2	729.47	182.37	60.79
1018	F	729.47	182.37	60.79
1019	C2	1,086.50	271.63	90.54
1101	Db	778.27	194.57	64.86
1102	D	737.18	184.30	61.43
1103	D	737.18	184.30	61.43
1104	D	737.18	184.30	61.43
1105	D	737.18	184.30	61.43
1106	D	737.18	184.30	61.43
1107	D1	1,298.41	324.60	108.20
1109	A	1,044.12	261.03	87.01
1110	E2	706.35	176.59	58.86
1111	E	706.35	176.59	58.86
1112	E	706.35	176.59	58.86
1113	E2	706.35	176.59	58.86
1114	B	1,274.01	318.50	106.17
1115	Fa	706.35	176.59	58.86
1116	F	729.47	182.37	60.79
1117	F2	729.47	182.37	60.79
1118	F	729.47	182.37	60.79
1119	C2	1,086.50	271.63	90.54
1201	Db	778.27	194.57	64.86
1202	D	737.18	184.30	61.43
1203	D	737.18	184.30	61.43
1204	D	737.18	184.30	61.43
1205	D	737.18	184.30	61.43
1206	D	737.18	184.30	61.43
1207	D1	1,298.41	324.60	108.20
1209	A	1,044.12	261.03	87.01
1210	E2	706.35	176.59	58.86
1211	E	706.35	176.59	58.86
1212	E	706.35	176.59	58.86
1213	E2	706.35	176.59	58.86
1214	B	1,274.01	318.50	106.17
1216	Fa	706.35	176.59	58.86
1216	F	729.47	182.37	60.79
1217	F2	729.47	182.37	60.79
1218	F	729.47	182.37	60.79
1219	C2	1,086.50	271.63	90.54
1401	Db	778.27	194.57	64.86
1402	D	737.18	184.30	61.43
1403	D	737.18	184.30	61.43
1404	D	737.18	184.30	61.43
1405	D	737.18	184.30	61.43
1406	D	737.18	184.30	61.43
1407	D1	1,298.41	324.60	108.20

Floor	Unit Type	Annual	Quarterly	Monthly
1409	A	1,044.12	261.03	87.01
1410	E2	706.35	176.59	58.86
1411	E	706.35	176.59	58.86
1412	E	706.35	176.59	58.86
1413	E2	706.35	176.59	58.86
1414	B	1,274.01	318.50	106.17
1415	Fa	706.35	176.59	58.86
1416	F	729.47	182.37	60.79
1417	F2	729.47	182.37	60.79
1418	F	729.47	182.37	60.79
1419	C2	1,086.50	271.63	90.54
1501	Db	778.27	194.57	64.86
1502	D	737.18	184.30	61.43
1503	D	737.18	184.30	61.43
1504	D	737.18	184.30	61.43
1505	D	737.18	184.30	61.43
1506	D	737.18	184.30	61.43
1507	D1	1,298.41	324.60	108.20
1509	A	1,044.12	261.03	87.01
1510	E2	706.35	176.59	58.86
1511	E	706.35	176.59	58.86
1512	E	706.35	176.59	58.86
1513	E2	706.35	176.59	58.86
1514	B	1,274.01	318.50	106.17
1515	Fa	706.35	176.59	58.86
1516	F	729.47	182.37	60.79
1517	F2	729.47	182.37	60.79
1518	F	729.47	182.37	60.79
1519	C2	1,086.50	271.63	90.54
1601	Db	778.27	194.57	64.86
1602	D	737.18	184.30	61.43
1603	D	737.18	184.30	61.43
1604	D	737.18	184.30	61.43
1605	D	737.18	184.30	61.43
1606	D	737.18	184.30	61.43
1607	D1	1,298.41	324.60	108.20
1609	A	1,044.12	261.03	87.01
1610	E2	706.35	176.59	58.86
1611	E	706.35	176.59	58.86
1612	E	706.35	176.59	58.86
1613	E2	706.35	176.59	58.86
1614	B	1,274.01	318.50	106.17
1615	Fa	706.35	176.59	58.86
1616	F	729.47	182.37	60.79
1617	F2	729.47	182.37	60.79
1618	F	729.47	182.37	60.79
1619	C2	1,086.50	271.63	90.54
1701	Db	778.27	194.57	64.86
1702	D	737.18	184.30	61.43
1703	D	737.18	184.30	61.43
1704	D	737.18	184.30	61.43
1705	D	737.18	184.30	61.43
1706	D	737.18	184.30	61.43
1707	D1	1,298.41	324.60	108.20
1709	A	1,044.12	261.03	87.01
1710	E2	706.35	176.59	58.86
1711	E	706.35	176.59	58.86
1712	E	706.35	176.59	58.86
1713	E2	706.35	176.59	58.86
1714	B	1,274.01	318.50	106.17
1715	Fa	706.35	176.59	58.86
1716	F	729.47	182.37	60.79
1717	F2	729.47	182.37	60.79

Floor	Unit Type	Annual	Quarterly	Monthly
1718	F	729.47	182.37	60.79
1719	C2	1,086.50	271.63	90.54
1801	Db	778.27	194.57	64.86
1802	D	737.18	184.30	61.43
1803	D	737.18	184.30	61.43
1804	D	737.18	184.30	61.43
1805	D	737.18	184.30	61.43
1806	D	737.18	184.30	61.43
1807	D1	1,298.41	324.60	108.20
1809	A2	1,370.33	342.58	114.19
1810	E	706.35	176.59	58.86
1811	E	706.35	176.59	58.86
1812	B2	1,582.23	395.56	131.85
1813	Fa	706.35	176.59	58.86
1814	F	729.47	182.37	60.79
1815	F2	729.47	182.37	60.79
1816	F	729.47	182.37	60.79
1817	C2	1,086.50	271.63	90.54
1901	Db	778.27	194.57	64.86
1902	D	737.18	184.30	61.43
1903	D	737.18	184.30	61.43
1904	D	737.18	184.30	61.43
1905	D	737.18	184.30	61.43
1906	D	737.18	184.30	61.43
1907	D1	1,298.41	324.60	108.20
1909	A2	1,370.33	342.58	114.19
1910	E	706.35	176.59	58.86
1911	E	706.35	176.59	58.86
1912	B2	1,582.23	395.56	131.85
1913	Fa	706.35	176.59	58.86
1914	F	729.47	182.37	60.79
1915	F2	729.47	182.37	60.79
1916	F	729.47	182.37	60.79
1917	C2	1,086.50	271.63	90.54
Hotel Unit	Commercial	203,066.41	50,764.10	16,921.37
Total		\$ 451,512.00	\$ 112,878.70	\$ 37,625.76

Note: In addition to the Guaranteed Assessments, each Owner shall be obligated to pay their proportionate share of the Hotel Shared Costs. See the Hotel Shared Costs budget for those amounts (which are not guaranteed).

Exhibit "7"
Shared Component Percentage Share

Unit		Percent Allocation
Floor	Type	
301	D2	0.34115756%
302	D	0.29670369%
303	D	0.29670369%
304	D	0.29670369%
305	D	0.29670369%
306	D	0.29670369%
307	D1	0.52259135%
309	J	0.42231170%
310	H	0.60219478%
311	G	0.28481487%
312	G	0.28481487%
313	G	0.28481487%
314	G	0.28481487%
315	G	0.28481487%
316	I	0.57324808%
317	G	0.28481487%
318	G2	0.40990597%
319	N	0.33805813%
320	M	0.32099825%
401	D2	0.34115756%
402	D	0.29670369%
403	D	0.29670369%
404	D	0.29670369%
405	D	0.29670369%
406	D	0.29670369%
407	D1	0.52259135%
409	J	0.42231170%
410	H	0.60219478%
411	G	0.28481487%
412	G	0.28481487%
413	G	0.28481487%
414	G	0.28481487%
415	G	0.28481487%
416	I	0.57324808%
417	G	0.28481487%
418	G2	0.40990597%
419	N	0.33805813%
420	M	0.32099825%
501	D2	0.34115756%
502	D	0.29670369%
503	D	0.29670369%
504	D	0.29670369%
505	D	0.29670369%
506	D	0.29670369%
507	D1	0.52259135%
509	A	0.42024408%
510	E2	0.28429796%
511	E	0.28429796%
512	TS	2.93757334%
520	K2	0.30238965%
521	K	0.32048134%
522	K	0.32048134%
523	L	0.57996785%
601	D2	0.34115756%
602	D	0.29670369%
603	D	0.29670369%
604	D	0.29670369%
605	D	0.29670369%
606	D	0.29670369%
607	D1	0.52259135%
609	A	0.42024408%
610	E2	0.28429796%
616	F	0.28360226%

Unit		Percent Allocation
Floor	Type	
617	F2	0.29360226%
618	F	0.29360226%
619	C1	0.44919078%
620	K2	0.30238965%
621	K	0.32048134%
622	K	0.32048134%
623	L	0.57996785%
701	D2	0.34115766%
702	D	0.29670369%
703	D	0.29670369%
704	D	0.29670369%
705	D	0.29670369%
706	D	0.29670369%
707	D1	0.52259135%
709	A	0.42024408%
710	E2	0.28429796%
711	E	0.28429796%
712	E	0.28429796%
713	E2	0.28429796%
714	B	0.51277015%
715	Fa	0.28429796%
716	F	0.29360226%
717	F2	0.29360226%
718	F	0.29360226%
719	C1	0.44919078%
720	K2	0.30238965%
721	K	0.32048134%
722	K	0.32048134%
723	L	0.57996785%
801	Db	0.31324467%
802	D	0.29670369%
803	D	0.29670369%
804	D	0.29670369%
805	D	0.29670369%
806	D	0.29670369%
807	D1	0.52259135%
809	A	0.42024408%
810	E2	0.28429796%
811	E	0.28429796%
812	E	0.28429796%
813	E2	0.28429796%
814	B	0.51277015%
815	Fa	0.28429796%
816	F	0.29360226%
817	F2	0.29360226%
818	F	0.29360226%
819	C1	0.44919078%
901	Db	0.31324467%
902	D	0.29670369%
903	D	0.29670369%
904	D	0.29670369%
905	D	0.29670369%
906	D	0.29670369%
907	D1	0.52259135%
909	A	0.42024408%
910	E2	0.28429796%
911	E	0.28429796%
912	E	0.28429796%
913	E2	0.28429796%
914	B	0.51277015%
915	Fa	0.28429796%
916	F	0.29360226%
917	F2	0.29360226%

Unit		Percent Allocation
Floor	Type	
918	F	0.29360226%
919	C2	0.43730196%
1001	Db	0.31324467%
1002	D	0.29670369%
1003	D	0.29670369%
1004	D	0.29670369%
1005	D	0.29670369%
1006	D	0.29670369%
1007	D1	0.52259135%
1009	A	0.42024406%
1010	E2	0.28429796%
1011	E	0.28429796%
1012	E	0.28429796%
1013	E2	0.28429796%
1014	B	0.51277015%
1015	Fa	0.28429796%
1016	F	0.29360226%
1017	F2	0.29360226%
1018	F	0.29360226%
1019	C2	0.43730196%
1101	Db	0.31324467%
1102	D	0.29670369%
1103	D	0.29670369%
1104	D	0.29670369%
1105	D	0.29670369%
1106	D	0.29670369%
1107	D1	0.52259135%
1109	A	0.42024406%
1110	E2	0.28429796%
1111	E	0.28429796%
1112	E	0.28429796%
1113	E2	0.28429796%
1114	B	0.51277015%
1115	Fa	0.28429796%
1116	F	0.29360226%
1117	F2	0.29360226%
1118	F	0.29360226%
1119	C2	0.43730196%
1201	Db	0.31324467%
1202	D	0.29670369%
1203	D	0.29670369%
1204	D	0.29670369%
1205	D	0.29670369%
1206	D	0.29670369%
1207	D1	0.52259135%
1209	A	0.42024406%
1210	E2	0.28429796%
1211	E	0.28429796%
1212	E	0.28429796%
1213	E2	0.28429796%
1214	B	0.51277015%
1216	Fa	0.28429796%
1218	F	0.29360226%
1217	F2	0.29360226%
1218	F	0.29360226%
1219	C2	0.43730196%
1401	Db	0.31324467%
1402	D	0.29670369%
1403	D	0.29670369%
1404	D	0.29670369%
1405	D	0.29670369%
1406	D	0.29670369%
1407	D1	0.52259135%

Unit		Percent Allocation
Floor	Type	
1409	A	0.42024408%
1410	E2	0.28429796%
1411	E	0.28429796%
1412	E	0.28429796%
1413	E2	0.28429796%
1414	B	0.51277015%
1415	Fa	0.28429796%
1418	F	0.29360226%
1417	F2	0.29360226%
1418	F	0.29360226%
1419	C2	0.43730196%
1601	Db	0.31324467%
1602	D	0.29670369%
1603	D	0.29670369%
1604	D	0.29670369%
1605	D	0.29670369%
1606	D	0.29670369%
1607	D1	0.52259135%
1609	A	0.42024408%
1610	E2	0.28429796%
1611	E	0.28429796%
1612	E	0.28429796%
1613	E2	0.28429796%
1614	B	0.51277015%
1615	Fa	0.28429796%
1616	F	0.29360226%
1617	F2	0.29360226%
1618	F	0.29360226%
1619	C2	0.43730196%
1801	Db	0.31324467%
1802	D	0.29670369%
1803	D	0.29670369%
1804	D	0.29670369%
1805	D	0.29670369%
1806	D	0.29670369%
1807	D1	0.52259135%
1809	A	0.42024408%
1810	E2	0.28429796%
1811	E	0.28429796%
1812	E	0.28429796%
1813	E2	0.28429796%
1814	B	0.51277015%
1815	Fa	0.28429796%
1816	F	0.29360226%
1817	F2	0.29360226%
1818	F	0.29360226%
1819	C2	0.43730196%
1701	Db	0.31324467%
1702	D	0.29670369%
1703	D	0.29670369%
1704	D	0.29670369%
1705	D	0.29670369%
1706	D	0.29670369%
1707	D1	0.52259135%
1709	A	0.42024408%
1710	E2	0.28429796%
1711	E	0.28429796%
1712	E	0.28429796%
1713	E2	0.28429796%
1714	B	0.51277015%
1715	Fa	0.28429796%
1716	F	0.29360226%
1717	F2	0.29360226%

Unit		Percent Allocation
Floor	Type	
1718	F	0.29360226%
1719	C2	0.43730196%
1801	Db	0.31324467%
1802	D	0.29670369%
1803	D	0.29670369%
1804	D	0.29670369%
1805	D	0.29670369%
1806	D	0.29670369%
1807	D1	0.52259135%
1809	A2	0.55153805%
1810	E	0.28429796%
1811	E	0.28429796%
1812	B2	0.63682744%
1813	Fa	0.28429796%
1814	F	0.29360226%
1815	F2	0.29360226%
1816	F	0.29360226%
1817	C2	0.43730196%
1901	Db	0.31324467%
1902	D	0.29670369%
1903	D	0.29670369%
1904	D	0.29670369%
1905	D	0.29670369%
1906	D	0.29670369%
1907	D1	0.52259135%
1909	A2	0.55153805%
1910	E	0.28429796%
1911	E	0.28429796%
1912	B2	0.63682744%
1913	Fa	0.28429796%
1914	F	0.29360226%
1915	F2	0.29360226%
1916	F	0.29360226%
1917	C2	0.43730196%
Total		100.0000000%

Exhibit "B"

Fontainebleau III Ocean Club Condominium Association, Inc.
Estimated Operating Budget
January 1, 2007- December 31, 2007
(286 Residential Units/1 Hotel Unit)

	<u>Annually</u>	<u>Monthly</u>
<u>Administrative expenses:</u>		
Legal fees	\$ 5,000	\$ 417
Accounting/tax preparation	4,200	350
Fees, licenses and permits	3,000	250
Taxes on Association property	N/A	N/A
Taxes on leased property	N/A	N/A
Rent for recreational and other commonly used facilities	N/A	N/A
Fees payable to Division	1,144	95
Postage and other expenses	1,904	159
Insurance	<u>5,000</u>	<u>417</u>
Total administrative expenses	20,248	1,688
Management Fees	N/A	N/A
Security Provisions	N/A	N/A
Other Expenses	N/A	N/A
Operating Capital	N/A	N/A
Reciprocal Easement Expenses	400,514	33,376
Maintenance (Note 1)	N/A	N/A
Utilities (Note 1)	<u>N/A</u>	<u>N/A</u>
Total operating expenses without reserves	420,762	35,064
Reserves - replacement and deferred maintenance		
Association reserves (Note 1)	N/A	N/A
Reciprocal Easement Expenses Reserves	<u>30,750</u>	<u>2,563</u>
Total budget	<u>\$ 451,512</u>	<u>\$ 37,627</u>

Note:

This budget covers the first year of operation of the Association, commencing upon the closing of the first Unit. The above assessments do not include the Hotel Shared Costs, Amenity Fees or expenses which are personal to Unit Owners such as private telephone service, mortgage and real estate tax payments upon Units, and the like.

(1) Inasmuch as the Common Elements do not include the roof of the building, the exterior surface of the building or paving, no reserves are established for roof replacement, pavement resurfacing and/or exterior painting.

Fontainebleau III Ocean Club Condominium Association, Inc.
January 1, 2007- December 31, 2007
Hotel Shared Costs Estimated Operating Budget

	<u>Annually</u>	<u>Monthly</u>
<u>Administrative Expenses:</u>		
Salaries & benefits:		
Administrative assistant	\$ 35,000	\$ 2,917
Engineer	75,000	6,250
Maintenance	73,000	6,083
Pool attendant	25,550	2,129
Entry attendant/security	192,720	16,060
Payroll taxes/benefits	160,508	13,376
Management fee	100,000	8,333
Employee uniforms	6,000	500
Accounting/bookkeeping	20,000	1,667
Property taxes	-	-
Legal fees	10,000	833
Fees, licenses and permits	7,500	625
Insurance	210,000	17,500
Total administrative expenses	<u>915,278</u>	<u>76,273</u>
<u>Operational expenses:</u>		
Elevator maintenance	65,000	5,417
Janitorial services	62,000	5,167
HVAC maintenance	35,000	2,917
Window washing	10,000	833
Interior lobby plants and flowers	15,000	1,250
Landscape maintenance	8,500	708
Repairs and maintenance	32,500	2,708
Pest control	13,500	1,125
Office	20,000	1,667
Life safety system	14,000	1,167
Fountain & swimming pool	25,000	2,083
Supplies	6,000	500
Signage	750	63
Hotel unit shared allocation	203,056	16,921
Contingency	30,000	2,500
Total operational expenses	<u>540,306</u>	<u>45,026</u>
<u>Utilities expense:</u>		
Electricity	399,029	33,252
Gas	50,000	4,167
Telephone and radio service	9,000	750
Water	33,500	2,792
Sewer	31,500	2,625
Total utilities expense	<u>523,029</u>	<u>43,586</u>
Total budget of the Hotel Shared Costs		
without reserves	<u>1,978,613</u>	<u>164,884</u>
Reserves	<u>176,750</u>	<u>14,729</u>
Association reserves	<u>10,000</u>	<u>833</u>
Total budget of the Hotel Shared Costs		
with reserves	<u>\$ 2,165,363</u>	<u>\$ 180,447</u>

Hotel Shared Costs Reserve Detail

			<u>Total Estimated Replacement Cost</u>	<u>Annual Reserve Assessment</u>	<u>Current Balance in Reserve Account</u>
Air conditioning					
Estimated useful life:	20				
Estimated remaining useful life:	20	\$1,526,000	\$76,300	\$ -	
Boilers and plumbing fixtures					
Estimated useful life:	20				
Estimated remaining useful life:	20	100,000	5,000	-	
Roof					
Estimated useful life:	20				
Estimated remaining useful life:	20	39,000	1,950	-	
Elevators					
Estimated useful life:	10				
Estimated remaining useful life:	10	40,000	4,000	-	
Painting (exterior & interior) and waterproofing					
Estimated useful life:	5				
Estimated remaining useful life:	5	100,000	20,000	-	
Carpet and flooring					
Estimated useful life:	5				
Estimated remaining useful life:	5	200,000	40,000	-	
Interior decorating					
Estimated useful life:	5				
Estimated remaining useful life:	5	100,000	20,000	-	
Security/fire safety					
Estimated useful life:	10				
Estimated remaining useful life:	10	70,000	7,000	-	
Contingency					
Estimated useful life:	4				
Estimated remaining useful life:	4	10,000	2,500	-	
Total Reserves		<u>\$2,185,000</u>	<u>\$176,750</u>	<u>\$ -</u>	

Fontainebleau III Ocean Club Condominium
Allocation of Assessments without Reserves

Unit	Type	Condominium Association	Hotel Shared Costs	Amenity Fee	Total Annual Assessment	Total Quarterly Assessment	Total Monthly Assessment
301	D2	\$ 789.90	\$ 6,750.19	\$ 720.00	\$ 8,280.09	\$ 2,065.02	\$ 688.34
302	D	686.97	5,870.62	720.00	7,277.59	1,819.40	606.47
303	D	686.97	5,870.62	720.00	7,277.59	1,819.40	606.47
304	D	686.97	5,870.62	720.00	7,277.59	1,819.40	606.47
305	D	686.97	5,870.62	720.00	7,277.59	1,819.40	606.47
306	D	686.97	5,870.62	720.00	7,277.59	1,819.40	606.47
307	D1	1,209.98	10,340.06	1,080.00	12,630.04	3,157.51	1,052.50
309	J	977.80	8,355.92	720.00	10,053.72	2,513.43	837.81
310	H	1,394.29	11,915.11	1,080.00	14,389.40	3,597.35	1,199.12
311	G	659.45	5,635.39	720.00	7,014.84	1,753.71	584.57
312	G	659.45	5,635.39	720.00	7,014.84	1,753.71	584.57
313	G	659.45	5,635.39	720.00	7,014.84	1,753.71	584.57
314	G	659.45	5,635.39	720.00	7,014.84	1,753.71	584.57
315	G	659.45	5,635.39	720.00	7,014.84	1,753.71	584.57
316	I	1,327.27	11,342.36	1,080.00	13,749.63	3,437.41	1,145.80
317	G	659.45	5,635.39	720.00	7,014.84	1,753.71	584.57
318	G2	949.07	8,110.45	720.00	9,779.52	2,444.88	814.96
319	N	782.72	6,688.82	720.00	8,191.54	2,047.89	682.63
320	M	743.22	6,351.31	720.00	7,814.53	1,953.63	651.21
401	D2	789.90	6,750.19	720.00	8,260.09	2,065.02	688.34
402	D	686.97	5,870.62	720.00	7,277.59	1,819.40	606.47
403	D	686.97	5,870.62	720.00	7,277.59	1,819.40	606.47
404	D	686.97	5,870.62	720.00	7,277.59	1,819.40	606.47
405	D	686.97	5,870.62	720.00	7,277.59	1,819.40	606.47
406	D	686.97	5,870.62	720.00	7,277.59	1,819.40	606.47
407	D1	1,209.98	10,340.06	1,080.00	12,630.04	3,157.51	1,052.50
409	J	977.80	8,355.92	720.00	10,053.72	2,513.43	837.81
410	H	1,394.29	11,915.11	1,080.00	14,389.40	3,597.35	1,199.12
411	G	659.45	5,635.39	720.00	7,014.84	1,753.71	584.57
412	G	659.45	5,635.39	720.00	7,014.84	1,753.71	584.57
413	G	659.45	5,635.39	720.00	7,014.84	1,753.71	584.57
414	G	659.45	5,635.39	720.00	7,014.84	1,753.71	584.57
415	G	659.45	5,635.39	720.00	7,014.84	1,753.71	584.57
416	I	1,327.27	11,342.36	1,080.00	13,749.63	3,437.41	1,145.80
417	G	659.45	5,635.39	720.00	7,014.84	1,753.71	584.57
418	G2	949.07	8,110.45	720.00	9,779.52	2,444.88	814.96
419	N	782.72	6,688.82	720.00	8,191.54	2,047.89	682.63
420	M	743.22	6,351.31	720.00	7,814.53	1,953.63	651.21
501	D2	789.90	6,750.19	720.00	8,260.09	2,065.02	688.34
502	D	686.97	5,870.62	720.00	7,277.59	1,819.40	606.47
503	D	686.97	5,870.62	720.00	7,277.59	1,819.40	606.47
504	D	686.97	5,870.62	720.00	7,277.59	1,819.40	606.47
505	D	686.97	5,870.62	720.00	7,277.59	1,819.40	606.47
506	D	686.97	5,870.62	720.00	7,277.59	1,819.40	606.47
507	D1	1,209.98	10,340.06	1,080.00	12,630.04	3,157.51	1,052.50
509	A	973.01	8,315.01	1,080.00	10,368.02	2,592.01	864.00
510	E2	658.25	5,625.16	720.00	7,003.41	1,750.85	583.62
511	E	658.25	5,625.16	720.00	7,003.41	1,750.85	583.62
512	TS	6,801.57	58,123.44	3,240.00	68,165.01	17,041.25	5,680.42
520	K2	700.14	5,983.12	720.00	7,403.26	1,850.82	616.94
521	K	742.03	6,341.09	720.00	7,803.12	1,950.78	650.26
522	K	742.03	6,341.09	720.00	7,803.12	1,950.78	650.26
523	L	1,342.83	11,475.32	1,080.00	13,898.15	3,474.54	1,158.18
601	D2	789.90	6,750.19	720.00	8,260.09	2,065.02	688.34
602	D	686.97	5,870.62	720.00	7,277.59	1,819.40	606.47
603	D	686.97	5,870.62	720.00	7,277.59	1,819.40	606.47
604	D	686.97	5,870.62	720.00	7,277.59	1,819.40	606.47
605	D	686.97	5,870.62	720.00	7,277.59	1,819.40	606.47
606	D	686.97	5,870.62	720.00	7,277.59	1,819.40	606.47
607	D1	1,209.98	10,340.06	1,080.00	12,630.04	3,157.51	1,052.50
609	A	973.01	8,315.01	1,080.00	10,368.02	2,592.01	864.00
610	E2	658.25	5,625.16	720.00	7,003.41	1,750.85	583.62
616	F	679.79	5,809.25	720.00	7,209.04	1,802.26	600.75
617	F2	679.79	5,809.25	720.00	7,209.04	1,802.26	600.75
618	F	679.79	5,809.25	720.00	7,209.04	1,802.26	600.75
619	C1	1,040.03	8,887.75	720.00	10,647.78	2,661.95	887.32

Unit	Type	Condominium Association	Hotel Shared Costs	Amenity Fee	Total Annual Assessment	Total Quarterly Assessment	Total Monthly Assessment
620	K2	700.14	5,983.12	720.00	7,403.26	1,850.82	616.94
621	K	742.03	6,341.09	720.00	7,803.12	1,950.78	650.26
622	K	742.03	6,341.09	720.00	7,803.12	1,950.78	650.26
623	L	1,342.83	11,475.32	1,080.00	13,898.15	3,474.54	1,158.18
701	D2	789.90	6,750.19	720.00	8,260.09	2,065.02	688.34
702	D	686.97	5,870.62	720.00	7,277.59	1,819.40	606.47
703	D	686.97	5,870.62	720.00	7,277.59	1,819.40	606.47
704	D	686.97	5,870.62	720.00	7,277.59	1,819.40	606.47
705	D	686.97	5,870.62	720.00	7,277.59	1,819.40	606.47
706	D	686.97	5,870.62	720.00	7,277.59	1,819.40	606.47
707	D1	1,209.98	10,340.06	1,080.00	12,630.04	3,157.51	1,052.50
709	A	973.01	8,315.01	1,080.00	10,368.02	2,592.01	864.00
710	E2	658.25	5,625.16	720.00	7,003.41	1,750.85	583.62
711	E	658.25	5,625.16	720.00	7,003.41	1,750.85	583.62
712	E	658.25	5,625.16	720.00	7,003.41	1,750.85	583.62
713	E2	658.25	5,625.16	720.00	7,003.41	1,750.85	583.62
714	B	1,187.24	10,145.74	1,080.00	12,412.98	3,103.25	1,034.42
715	Fa	658.25	5,625.16	720.00	7,003.41	1,750.85	583.62
716	F	679.79	5,809.25	720.00	7,209.04	1,802.26	600.75
717	F2	679.79	5,809.25	720.00	7,209.04	1,802.26	600.75
718	F	679.79	5,809.25	720.00	7,209.04	1,802.26	600.75
719	C1	1,040.03	8,887.75	720.00	10,647.78	2,661.95	887.32
720	K2	700.14	5,983.12	720.00	7,403.26	1,850.82	616.94
721	K	742.03	6,341.09	720.00	7,803.12	1,950.78	650.26
722	K	742.03	6,341.09	720.00	7,803.12	1,950.78	650.26
723	L	1,342.83	11,475.32	1,080.00	13,898.15	3,474.54	1,158.18
801	Db	725.27	6,197.90	720.00	7,643.17	1,910.79	636.93
802	D	686.97	5,870.62	720.00	7,277.59	1,819.40	606.47
803	D	686.97	5,870.62	720.00	7,277.59	1,819.40	606.47
804	D	686.97	5,870.62	720.00	7,277.59	1,819.40	606.47
805	D	686.97	5,870.62	720.00	7,277.59	1,819.40	606.47
806	D	686.97	5,870.62	720.00	7,277.59	1,819.40	606.47
807	D1	1,209.98	10,340.06	1,080.00	12,630.04	3,157.51	1,052.50
809	A	973.01	8,315.01	1,080.00	10,368.02	2,592.01	864.00
810	E2	658.25	5,625.16	720.00	7,003.41	1,750.85	583.62
811	E	658.25	5,625.16	720.00	7,003.41	1,750.85	583.62
812	E	658.25	5,625.16	720.00	7,003.41	1,750.85	583.62
813	E2	658.25	5,625.16	720.00	7,003.41	1,750.85	583.62
814	B	1,187.24	10,145.74	1,080.00	12,412.98	3,103.25	1,034.42
815	Fa	658.25	5,625.16	720.00	7,003.41	1,750.85	583.62
816	F	679.79	5,809.25	720.00	7,209.04	1,802.26	600.75
817	F2	679.79	5,809.25	720.00	7,209.04	1,802.26	600.75
818	F	679.79	5,809.25	720.00	7,209.04	1,802.26	600.75
819	C1	1,040.03	8,887.75	720.00	10,647.78	2,661.95	887.32
901	Db	725.27	6,197.90	720.00	7,643.17	1,910.79	636.93
902	D	686.97	5,870.62	720.00	7,277.59	1,819.40	606.47
903	D	686.97	5,870.62	720.00	7,277.59	1,819.40	606.47
904	D	686.97	5,870.62	720.00	7,277.59	1,819.40	606.47
905	D	686.97	5,870.62	720.00	7,277.59	1,819.40	606.47
906	D	686.97	5,870.62	720.00	7,277.59	1,819.40	606.47
907	D1	1,209.98	10,340.06	1,080.00	12,630.04	3,157.51	1,052.50
909	A	973.01	8,315.01	1,080.00	10,368.02	2,592.01	864.00
910	E2	658.25	5,625.16	720.00	7,003.41	1,750.85	583.62
911	E	658.25	5,625.16	720.00	7,003.41	1,750.85	583.62
912	E	658.25	5,625.16	720.00	7,003.41	1,750.85	583.62
913	E2	658.25	5,625.16	720.00	7,003.41	1,750.85	583.62
914	B	1,187.24	10,145.74	1,080.00	12,412.98	3,103.25	1,034.42
915	Fa	658.25	5,625.16	720.00	7,003.41	1,750.85	583.62
916	F	679.79	5,809.25	720.00	7,209.04	1,802.26	600.75
917	F2	679.79	5,809.25	720.00	7,209.04	1,802.26	600.75
918	F	679.79	5,809.25	720.00	7,209.04	1,802.26	600.75
919	C2	1,012.51	8,652.52	720.00	10,385.03	2,596.26	865.42
1001	Db	725.27	6,197.90	720.00	7,643.17	1,910.79	636.93
1002	D	686.97	5,870.62	720.00	7,277.59	1,819.40	606.47
1003	D	686.97	5,870.62	720.00	7,277.59	1,819.40	606.47

Unit	Type	Condominium Association	Hotel Shared Costs	Amenity Fee	Total Annual Assessment	Total Quarterly Assessment	Total Monthly Assessment
1004	D	686.97	5,870.82	720.00	7,277.59	1,819.40	606.47
1005	D	686.97	5,870.82	720.00	7,277.59	1,819.40	606.47
1006	D	686.97	5,870.82	720.00	7,277.59	1,819.40	606.47
1007	D1	1,209.98	10,340.06	1,080.00	12,630.04	3,157.51	1,052.50
1009	A	973.01	8,315.01	1,080.00	10,368.02	2,592.01	864.00
1010	E2	658.25	5,625.16	720.00	7,003.41	1,750.85	583.62
1011	E	658.25	5,625.16	720.00	7,003.41	1,750.85	583.62
1012	E	658.25	5,625.16	720.00	7,003.41	1,750.85	583.62
1013	E2	658.25	5,625.16	720.00	7,003.41	1,750.85	583.62
1014	B	1,187.24	10,145.74	1,080.00	12,412.98	3,103.25	1,034.42
1015	Fa	658.25	5,625.16	720.00	7,003.41	1,750.85	583.62
1016	F	679.79	5,809.25	720.00	7,209.04	1,802.26	600.75
1017	F2	679.79	5,809.25	720.00	7,209.04	1,802.26	600.75
1018	F	679.79	5,809.25	720.00	7,209.04	1,802.26	600.75
1019	C2	1,012.51	8,652.52	720.00	10,385.03	2,596.26	865.42
1101	Db	725.27	6,197.90	720.00	7,643.17	1,910.79	636.93
1102	D	686.97	5,870.82	720.00	7,277.59	1,819.40	606.47
1103	D	686.97	5,870.82	720.00	7,277.59	1,819.40	606.47
1104	D	686.97	5,870.82	720.00	7,277.59	1,819.40	606.47
1105	D	686.97	5,870.82	720.00	7,277.59	1,819.40	606.47
1106	D	686.97	5,870.82	720.00	7,277.59	1,819.40	606.47
1107	D1	1,209.98	10,340.06	1,080.00	12,630.04	3,157.51	1,052.50
1109	A	973.01	8,315.01	1,080.00	10,368.02	2,592.01	864.00
1110	E2	658.25	5,625.16	720.00	7,003.41	1,750.85	583.62
1111	E	658.25	5,625.16	720.00	7,003.41	1,750.85	583.62
1112	E	658.25	5,625.16	720.00	7,003.41	1,750.85	583.62
1113	E2	658.25	5,625.16	720.00	7,003.41	1,750.85	583.62
1114	B	1,187.24	10,145.74	1,080.00	12,412.98	3,103.25	1,034.42
1115	Fa	658.25	5,625.16	720.00	7,003.41	1,750.85	583.62
1116	F	679.79	5,809.25	720.00	7,209.04	1,802.26	600.75
1117	F2	679.79	5,809.25	720.00	7,209.04	1,802.26	600.75
1118	F	679.79	5,809.25	720.00	7,209.04	1,802.26	600.75
1119	C2	1,012.51	8,652.52	720.00	10,385.03	2,596.26	865.42
1201	Db	725.27	6,197.90	720.00	7,643.17	1,910.79	636.93
1202	D	686.97	5,870.82	720.00	7,277.59	1,819.40	606.47
1203	D	686.97	5,870.82	720.00	7,277.59	1,819.40	606.47
1204	D	686.97	5,870.82	720.00	7,277.59	1,819.40	606.47
1205	D	686.97	5,870.82	720.00	7,277.59	1,819.40	606.47
1206	D	686.97	5,870.82	720.00	7,277.59	1,819.40	606.47
1207	D1	1,209.98	10,340.06	1,080.00	12,630.04	3,157.51	1,052.50
1209	A	973.01	8,315.01	1,080.00	10,368.02	2,592.01	864.00
1210	E2	658.25	5,625.16	720.00	7,003.41	1,750.85	583.62
1211	E	658.25	5,625.16	720.00	7,003.41	1,750.85	583.62
1212	E	658.25	5,625.16	720.00	7,003.41	1,750.85	583.62
1213	E2	658.25	5,625.16	720.00	7,003.41	1,750.85	583.62
1214	B	1,187.24	10,145.74	1,080.00	12,412.98	3,103.25	1,034.42
1215	Fa	658.25	5,625.16	720.00	7,003.41	1,750.85	583.62
1216	F	679.79	5,809.25	720.00	7,209.04	1,802.26	600.75
1217	F2	679.79	5,809.25	720.00	7,209.04	1,802.26	600.75
1218	F	679.79	5,809.25	720.00	7,209.04	1,802.26	600.75
1219	C2	1,012.51	8,652.52	720.00	10,385.03	2,596.26	865.42
1401	Db	725.27	6,197.90	720.00	7,643.17	1,910.79	636.93
1402	D	686.97	5,870.82	720.00	7,277.59	1,819.40	606.47
1403	D	686.97	5,870.82	720.00	7,277.59	1,819.40	606.47
1404	D	686.97	5,870.82	720.00	7,277.59	1,819.40	606.47
1405	D	686.97	5,870.82	720.00	7,277.59	1,819.40	606.47
1406	D	686.97	5,870.82	720.00	7,277.59	1,819.40	606.47
1407	D1	1,209.98	10,340.06	1,080.00	12,630.04	3,157.51	1,052.50
1409	A	973.01	8,315.01	1,080.00	10,368.02	2,592.01	864.00
1410	E2	658.25	5,625.16	720.00	7,003.41	1,750.85	583.62
1411	E	658.25	5,625.16	720.00	7,003.41	1,750.85	583.62
1412	E	658.25	5,625.16	720.00	7,003.41	1,750.85	583.62
1413	E2	658.25	5,625.16	720.00	7,003.41	1,750.85	583.62
1414	B	1,187.24	10,145.74	1,080.00	12,412.98	3,103.25	1,034.42
1415	Fa	658.25	5,625.16	720.00	7,003.41	1,750.85	583.62

Unit	Type	Condominium Association	Hotel Shared Costs	Amenity Fee	Total Annual Assessment	Total Quarterly Assessment	Total Monthly Assessment
1416	F	679.79	5,809.25	720.00	7,209.04	1,802.26	600.75
1417	F2	679.79	5,809.25	720.00	7,209.04	1,802.26	600.75
1418	F	679.79	5,809.25	720.00	7,209.04	1,802.26	600.75
1419	C2	1,012.51	8,652.52	720.00	10,385.03	2,596.26	865.42
1501	Db	725.27	6,197.90	720.00	7,643.17	1,910.79	636.93
1502	D	686.97	5,870.62	720.00	7,277.59	1,819.40	606.47
1503	D	686.97	5,870.62	720.00	7,277.59	1,819.40	606.47
1504	D	686.97	5,870.62	720.00	7,277.59	1,819.40	606.47
1505	D	686.97	5,870.62	720.00	7,277.59	1,819.40	606.47
1506	D	686.97	5,870.62	720.00	7,277.59	1,819.40	606.47
1507	D1	1,209.98	10,340.08	1,080.00	12,630.04	3,157.51	1,052.50
1509	A	973.01	8,315.01	1,080.00	10,368.02	2,592.01	864.00
1510	E2	658.25	5,625.16	720.00	7,003.41	1,750.85	583.62
1511	E	658.25	5,625.16	720.00	7,003.41	1,750.85	583.62
1512	E	658.25	5,625.16	720.00	7,003.41	1,750.85	583.62
1513	E2	658.25	5,625.16	720.00	7,003.41	1,750.85	583.62
1514	B	1,187.24	10,145.74	1,080.00	12,412.98	3,103.25	1,034.42
1515	Fa	658.25	5,625.16	720.00	7,003.41	1,750.85	583.62
1516	F	679.79	5,809.25	720.00	7,209.04	1,802.26	600.75
1517	F2	679.79	5,809.25	720.00	7,209.04	1,802.26	600.75
1518	F	679.79	5,809.25	720.00	7,209.04	1,802.26	600.75
1519	C2	1,012.51	8,652.52	720.00	10,385.03	2,596.26	865.42
1601	Db	725.27	6,197.90	720.00	7,643.17	1,910.79	636.93
1602	D	686.97	5,870.62	720.00	7,277.59	1,819.40	606.47
1603	D	686.97	5,870.62	720.00	7,277.59	1,819.40	606.47
1604	D	686.97	5,870.62	720.00	7,277.59	1,819.40	606.47
1605	D	686.97	5,870.62	720.00	7,277.59	1,819.40	606.47
1606	D	686.97	5,870.62	720.00	7,277.59	1,819.40	606.47
1607	D1	1,209.98	10,340.08	1,080.00	12,630.04	3,157.51	1,052.50
1609	A	973.01	8,315.01	1,080.00	10,368.02	2,592.01	864.00
1610	E2	658.25	5,625.16	720.00	7,003.41	1,750.85	583.62
1611	E	658.25	5,625.16	720.00	7,003.41	1,750.85	583.62
1612	E	658.25	5,625.16	720.00	7,003.41	1,750.85	583.62
1613	E2	658.25	5,625.16	720.00	7,003.41	1,750.85	583.62
1614	B	1,187.24	10,145.74	1,080.00	12,412.98	3,103.25	1,034.42
1615	Fa	658.25	5,625.16	720.00	7,003.41	1,750.85	583.62
1616	F	679.79	5,809.25	720.00	7,209.04	1,802.26	600.75
1617	F2	679.79	5,809.25	720.00	7,209.04	1,802.26	600.75
1618	F	679.79	5,809.25	720.00	7,209.04	1,802.26	600.75
1619	C2	1,012.51	8,652.52	720.00	10,385.03	2,596.26	865.42
1701	Db	725.27	6,197.90	720.00	7,643.17	1,910.79	636.93
1702	D	686.97	5,870.62	720.00	7,277.59	1,819.40	606.47
1703	D	686.97	5,870.62	720.00	7,277.59	1,819.40	606.47
1704	D	686.97	5,870.62	720.00	7,277.59	1,819.40	606.47
1705	D	686.97	5,870.62	720.00	7,277.59	1,819.40	606.47
1706	D	686.97	5,870.62	720.00	7,277.59	1,819.40	606.47
1707	D1	1,209.98	10,340.08	1,080.00	12,630.04	3,157.51	1,052.50
1709	A	973.01	8,315.01	1,080.00	10,368.02	2,592.01	864.00
1710	E2	658.25	5,625.16	720.00	7,003.41	1,750.85	583.62
1711	E	658.25	5,625.16	720.00	7,003.41	1,750.85	583.62
1712	E	658.25	5,625.16	720.00	7,003.41	1,750.85	583.62
1713	E2	658.25	5,625.16	720.00	7,003.41	1,750.85	583.62
1714	B	1,187.24	10,145.74	1,080.00	12,412.98	3,103.25	1,034.42
1715	Fa	658.25	5,625.16	720.00	7,003.41	1,750.85	583.62
1716	F	679.79	5,809.25	720.00	7,209.04	1,802.26	600.75
1717	F2	679.79	5,809.25	720.00	7,209.04	1,802.26	600.75
1718	F	679.79	5,809.25	720.00	7,209.04	1,802.26	600.75
1719	C2	1,012.51	8,652.52	720.00	10,385.03	2,596.26	865.42
1801	Db	725.27	6,197.90	720.00	7,643.17	1,910.79	636.93
1802	D	686.97	5,870.62	720.00	7,277.59	1,819.40	606.47
1803	D	686.97	5,870.62	720.00	7,277.59	1,819.40	606.47
1804	D	686.97	5,870.62	720.00	7,277.59	1,819.40	606.47
1805	D	686.97	5,870.62	720.00	7,277.59	1,819.40	606.47
1806	D	686.97	5,870.62	720.00	7,277.59	1,819.40	606.47
1807	D1	1,209.98	10,340.08	1,080.00	12,630.04	3,157.51	1,052.50

Unit	Type	Condominium Association	Hotel Shared Costs	Amenity Fee	Total Annual Assessment	Total Quarterly Assessment	Total Monthly Assessment
1809	A2	1,277.00	10,912.81	1,080.00	13,269.81	3,317.45	1,105.82
1810	E	658.25	5,825.16	720.00	7,003.41	1,750.85	583.62
1811	E	658.25	5,825.16	720.00	7,003.41	1,750.85	583.62
1812	B2	1,474.48	12,600.35	1,080.00	15,154.83	3,788.71	1,262.90
1813	Fa	658.25	5,825.16	720.00	7,003.41	1,750.85	583.62
1814	F	679.79	5,809.25	720.00	7,209.04	1,802.26	600.75
1815	F2	679.79	5,809.25	720.00	7,209.04	1,802.26	600.75
1816	F	679.79	5,809.25	720.00	7,209.04	1,802.26	600.75
1817	C2	1,012.51	8,652.52	720.00	10,385.03	2,596.26	865.42
1901	Db	725.27	6,197.90	720.00	7,643.17	1,910.79	636.93
1902	D	686.97	5,870.82	720.00	7,277.59	1,819.40	606.47
1903	D	686.97	5,870.82	720.00	7,277.59	1,819.40	606.47
1904	D	686.97	5,870.82	720.00	7,277.59	1,819.40	606.47
1905	D	686.97	5,870.82	720.00	7,277.59	1,819.40	606.47
1906	D	686.97	5,870.82	720.00	7,277.59	1,819.40	606.47
1907	D1	1,209.98	10,340.06	1,080.00	12,630.04	3,157.51	1,052.50
1909	A2	1,277.00	10,912.81	1,080.00	13,269.81	3,317.45	1,105.82
1910	E	658.25	5,825.16	720.00	7,003.41	1,750.85	583.62
1911	E	658.25	5,825.16	720.00	7,003.41	1,750.85	583.62
1912	B2	1,474.48	12,600.35	1,080.00	15,154.83	3,788.71	1,262.90
1913	Fa	658.25	5,825.16	720.00	7,003.41	1,750.85	583.62
1914	F	679.79	5,809.25	720.00	7,209.04	1,802.26	600.75
1915	F2	679.79	5,809.25	720.00	7,209.04	1,802.26	600.75
1916	F	679.79	5,809.25	720.00	7,209.04	1,802.26	600.75
1917	C2	1,012.51	8,652.52	720.00	10,385.03	2,596.26	865.42
Hotel Unit	Commercial	189,227.29	-	-	189,227.29	47,306.82	15,768.94
Total		\$ 420,762.07	\$ 1,978,613.81	\$ 226,080.00	\$ 2,625,455.83	\$ 656,363.97	\$ 218,787.99

Fontainebleau III Ocean Club Condominium
Allocation of Assessments with Reserves

Unit	Type	Condominium Association	Hotel Shared Costs	Amenity Fee	Total Annual Assessment	Total Quarterly Assessment	Total Monthly Assessment
301	D2	\$ 847.83	\$ 7,387.30	\$ 720.00	\$ 8,954.93	\$ 2,238.73	\$ 746.24
302	D	737.18	6,424.71	720.00	7,881.89	1,970.47	656.82
303	D	737.18	6,424.71	720.00	7,881.89	1,970.47	656.82
304	D	737.18	6,424.71	720.00	7,881.89	1,970.47	656.82
305	D	737.18	6,424.71	720.00	7,881.89	1,970.47	656.82
306	D	737.18	6,424.71	720.00	7,881.89	1,970.47	656.82
307	D1	1,298.41	11,316.00	1,080.00	13,694.41	3,423.60	1,141.20
309	J	1,049.26	9,144.58	720.00	10,913.84	2,728.46	909.49
310	H	1,498.19	13,039.71	1,080.00	15,615.90	3,903.98	1,301.33
311	G	707.64	6,167.28	720.00	7,594.92	1,898.73	632.91
312	G	707.64	6,167.28	720.00	7,594.92	1,898.73	632.91
313	G	707.64	6,167.28	720.00	7,594.92	1,898.73	632.91
314	G	707.64	6,167.28	720.00	7,594.92	1,898.73	632.91
315	G	707.64	6,167.28	720.00	7,594.92	1,898.73	632.91
316	I	1,424.27	12,412.90	1,080.00	14,917.17	3,729.29	1,243.10
317	G	707.64	6,167.28	720.00	7,594.92	1,898.73	632.91
318	G2	1,018.43	8,875.95	720.00	10,614.38	2,653.60	884.53
319	N	839.92	7,320.14	720.00	8,880.06	2,220.02	740.01
320	M	797.54	6,950.78	720.00	8,468.32	2,117.08	705.69
401	D2	847.83	7,387.30	720.00	8,954.93	2,238.73	746.24
402	D	737.18	6,424.71	720.00	7,881.89	1,970.47	656.82
403	D	737.18	6,424.71	720.00	7,881.89	1,970.47	656.82
404	D	737.18	6,424.71	720.00	7,881.89	1,970.47	656.82
405	D	737.18	6,424.71	720.00	7,881.89	1,970.47	656.82
406	D	737.18	6,424.71	720.00	7,881.89	1,970.47	656.82
407	D1	1,298.41	11,316.00	1,080.00	13,694.41	3,423.60	1,141.20
409	J	1,049.26	9,144.58	720.00	10,913.84	2,728.46	909.49
410	H	1,498.19	13,039.71	1,080.00	15,615.90	3,903.98	1,301.33
411	G	707.64	6,167.28	720.00	7,594.92	1,898.73	632.91
412	G	707.64	6,167.28	720.00	7,594.92	1,898.73	632.91
413	G	707.64	6,167.28	720.00	7,594.92	1,898.73	632.91
414	G	707.64	6,167.28	720.00	7,594.92	1,898.73	632.91
415	G	707.64	6,167.28	720.00	7,594.92	1,898.73	632.91
416	I	1,424.27	12,412.90	1,080.00	14,917.17	3,729.29	1,243.10
417	G	707.64	6,167.28	720.00	7,594.92	1,898.73	632.91
418	G2	1,018.43	8,875.95	720.00	10,614.38	2,653.60	884.53
419	N	839.92	7,320.14	720.00	8,880.06	2,220.02	740.01
420	M	797.54	6,950.78	720.00	8,468.32	2,117.08	705.69
501	D2	847.83	7,387.30	720.00	8,954.93	2,238.73	746.24
502	D	737.18	6,424.71	720.00	7,881.89	1,970.47	656.82
503	D	737.18	6,424.71	720.00	7,881.89	1,970.47	656.82
504	D	737.18	6,424.71	720.00	7,881.89	1,970.47	656.82
505	D	737.18	6,424.71	720.00	7,881.89	1,970.47	656.82
506	D	737.18	6,424.71	720.00	7,881.89	1,970.47	656.82
507	D1	1,298.41	11,316.00	1,080.00	13,694.41	3,423.60	1,141.20
509	A	1,044.12	9,099.81	1,080.00	11,223.93	2,805.98	935.33
510	E2	708.35	6,158.08	720.00	7,582.43	1,895.61	631.87
511	E	708.35	6,158.08	720.00	7,582.43	1,895.61	631.87
512	TS	7,298.57	63,809.34	3,240.00	74,147.91	18,536.98	6,178.99
520	K2	751.30	6,547.83	720.00	8,019.13	2,004.78	668.26
521	K	796.25	6,939.59	720.00	8,455.84	2,113.96	704.65
522	K	796.25	6,939.59	720.00	8,455.84	2,113.96	704.65
523	L	1,440.96	12,558.41	1,080.00	15,079.37	3,769.84	1,256.61
601	D2	847.83	7,387.30	720.00	8,954.93	2,238.73	746.24
602	D	737.18	6,424.71	720.00	7,881.89	1,970.47	656.82
603	D	737.18	6,424.71	720.00	7,881.89	1,970.47	656.82
604	D	737.18	6,424.71	720.00	7,881.89	1,970.47	656.82
605	D	737.18	6,424.71	720.00	7,881.89	1,970.47	656.82
606	D	737.18	6,424.71	720.00	7,881.89	1,970.47	656.82
607	D1	1,298.41	11,316.00	1,080.00	13,694.41	3,423.60	1,141.20
609	A	1,044.12	9,099.81	1,080.00	11,223.93	2,805.98	935.33
610	E2	708.35	6,158.08	720.00	7,582.43	1,895.61	631.87
616	F	729.47	6,357.58	720.00	7,807.03	1,951.76	650.59
617	F2	729.47	6,357.58	720.00	7,807.03	1,951.76	650.59
618	F	729.47	6,357.58	720.00	7,807.03	1,951.76	650.59
619	C1	1,116.04	9,726.61	720.00	11,562.65	2,890.66	963.55

Unit	Type	Condominium Association	Hotel Shared Costs	Amenity Fee	Total Annual Assessment	Total Quarterly Assessment	Total Monthly Assessment
620	K2	751.30	6,547.83	720.00	8,019.13	2,004.78	668.28
621	K	796.25	6,939.59	720.00	8,455.84	2,113.96	704.65
622	K	796.25	6,939.59	720.00	8,455.84	2,113.96	704.65
623	L	1,440.98	12,558.41	1,080.00	15,079.37	3,769.84	1,256.61
701	D2	847.63	7,387.30	720.00	8,954.93	2,238.73	746.24
702	D	737.18	6,424.71	720.00	7,881.89	1,970.47	656.82
703	D	737.18	6,424.71	720.00	7,881.89	1,970.47	656.82
704	D	737.18	6,424.71	720.00	7,881.89	1,970.47	656.82
705	D	737.18	6,424.71	720.00	7,881.89	1,970.47	656.82
706	D	737.18	6,424.71	720.00	7,881.89	1,970.47	656.82
707	D1	1,298.41	11,316.00	1,080.00	13,694.41	3,423.60	1,141.20
709	A	1,044.12	9,099.81	1,080.00	11,223.93	2,805.98	935.33
710	E2	706.35	6,156.08	720.00	7,582.43	1,895.61	631.87
711	E	706.35	6,156.08	720.00	7,582.43	1,895.61	631.87
712	E	706.35	6,156.08	720.00	7,582.43	1,895.61	631.87
713	E2	706.35	6,156.08	720.00	7,582.43	1,895.61	631.87
714	B	1,274.01	11,103.34	1,080.00	13,457.35	3,364.34	1,121.45
715	Fa	706.35	6,156.08	720.00	7,582.43	1,895.61	631.87
716	F	729.47	6,357.56	720.00	7,807.03	1,951.76	650.59
717	F2	729.47	6,357.56	720.00	7,807.03	1,951.76	650.59
718	F	729.47	6,357.56	720.00	7,807.03	1,951.76	650.59
719	C1	1,116.04	9,726.81	720.00	11,562.65	2,890.66	963.55
720	K2	751.30	6,547.83	720.00	8,019.13	2,004.78	668.28
721	K	796.25	6,939.59	720.00	8,455.84	2,113.96	704.65
722	K	796.25	6,939.59	720.00	8,455.84	2,113.96	704.65
723	L	1,440.98	12,558.41	1,080.00	15,079.37	3,769.84	1,256.61
801	Db	778.27	6,782.89	720.00	8,281.16	2,070.29	690.10
802	D	737.18	6,424.71	720.00	7,881.89	1,970.47	656.82
803	D	737.18	6,424.71	720.00	7,881.89	1,970.47	656.82
804	D	737.18	6,424.71	720.00	7,881.89	1,970.47	656.82
805	D	737.18	6,424.71	720.00	7,881.89	1,970.47	656.82
806	D	737.18	6,424.71	720.00	7,881.89	1,970.47	656.82
807	D1	1,298.41	11,316.00	1,080.00	13,694.41	3,423.60	1,141.20
809	A	1,044.12	9,099.81	1,080.00	11,223.93	2,805.98	935.33
810	E2	706.35	6,156.08	720.00	7,582.43	1,895.61	631.87
811	E	706.35	6,156.08	720.00	7,582.43	1,895.61	631.87
812	E	706.35	6,156.08	720.00	7,582.43	1,895.61	631.87
813	E2	706.35	6,156.08	720.00	7,582.43	1,895.61	631.87
814	B	1,274.01	11,103.34	1,080.00	13,457.35	3,364.34	1,121.45
815	Fa	706.35	6,156.08	720.00	7,582.43	1,895.61	631.87
816	F	729.47	6,357.56	720.00	7,807.03	1,951.76	650.59
817	F2	729.47	6,357.56	720.00	7,807.03	1,951.76	650.59
818	F	729.47	6,357.56	720.00	7,807.03	1,951.76	650.59
819	C1	1,116.04	9,726.81	720.00	11,562.65	2,890.66	963.55
901	Db	778.27	6,782.89	720.00	8,281.16	2,070.29	690.10
902	D	737.18	6,424.71	720.00	7,881.89	1,970.47	656.82
903	D	737.18	6,424.71	720.00	7,881.89	1,970.47	656.82
904	D	737.18	6,424.71	720.00	7,881.89	1,970.47	656.82
905	D	737.18	6,424.71	720.00	7,881.89	1,970.47	656.82
906	D	737.18	6,424.71	720.00	7,881.89	1,970.47	656.82
907	D1	1,298.41	11,316.00	1,080.00	13,694.41	3,423.60	1,141.20
909	A	1,044.12	9,099.81	1,080.00	11,223.93	2,805.98	935.33
910	E2	706.35	6,156.08	720.00	7,582.43	1,895.61	631.87
911	E	706.35	6,156.08	720.00	7,582.43	1,895.61	631.87
912	E	706.35	6,156.08	720.00	7,582.43	1,895.61	631.87
913	E2	706.35	6,156.08	720.00	7,582.43	1,895.61	631.87
914	B	1,274.01	11,103.34	1,080.00	13,457.35	3,364.34	1,121.45
915	Fa	706.35	6,156.08	720.00	7,582.43	1,895.61	631.87
916	F	729.47	6,357.56	720.00	7,807.03	1,951.76	650.59
917	F2	729.47	6,357.56	720.00	7,807.03	1,951.76	650.59
918	F	729.47	6,357.56	720.00	7,807.03	1,951.76	650.59
919	C2	1,088.50	9,469.18	720.00	11,275.68	2,818.92	939.64
1001	Db	778.27	6,782.89	720.00	8,281.16	2,070.29	690.10
1002	D	737.18	6,424.71	720.00	7,881.89	1,970.47	656.82
1003	D	737.18	6,424.71	720.00	7,881.89	1,970.47	656.82

Unit	Type	Condominium Association	Hotel Shared Costs	Amenity Fee	Total Annual Assessment	Total Quarterly Assessment	Total Monthly Assessment
1004	D	737.18	6,424.71	720.00	7,881.89	1,970.47	656.82
1005	D	737.18	6,424.71	720.00	7,881.89	1,970.47	656.82
1006	D	737.18	6,424.71	720.00	7,881.89	1,970.47	656.82
1007	D1	1,298.41	11,316.00	1,080.00	13,694.41	3,423.60	1,141.20
1009	A	1,044.12	9,099.81	1,080.00	11,223.93	2,805.98	935.33
1010	E2	706.35	6,156.08	720.00	7,582.43	1,895.61	631.87
1011	E	706.35	6,156.08	720.00	7,582.43	1,895.61	631.87
1012	E	706.35	6,156.08	720.00	7,582.43	1,895.61	631.87
1013	E2	706.35	6,156.08	720.00	7,582.43	1,895.61	631.87
1014	B	1,274.01	11,103.34	1,080.00	13,457.35	3,364.34	1,121.45
1015	Fa	706.35	6,156.08	720.00	7,582.43	1,895.61	631.87
1016	F	729.47	6,357.56	720.00	7,807.03	1,951.76	650.59
1017	F2	729.47	6,357.56	720.00	7,807.03	1,951.76	650.59
1018	F	729.47	6,357.56	720.00	7,807.03	1,951.76	650.59
1019	C2	1,086.50	9,469.18	720.00	11,275.68	2,818.92	939.64
1101	Db	778.27	6,782.89	720.00	8,281.16	2,070.29	690.10
1102	D	737.18	6,424.71	720.00	7,881.89	1,970.47	656.82
1103	D	737.18	6,424.71	720.00	7,881.89	1,970.47	656.82
1104	D	737.18	6,424.71	720.00	7,881.89	1,970.47	656.82
1105	D	737.18	6,424.71	720.00	7,881.89	1,970.47	656.82
1106	D	737.18	6,424.71	720.00	7,881.89	1,970.47	656.82
1107	D1	1,298.41	11,316.00	1,080.00	13,694.41	3,423.60	1,141.20
1109	A	1,044.12	9,099.81	1,080.00	11,223.93	2,805.98	935.33
1110	E2	706.35	6,156.08	720.00	7,582.43	1,895.61	631.87
1111	E	706.35	6,156.08	720.00	7,582.43	1,895.61	631.87
1112	E	706.35	6,156.08	720.00	7,582.43	1,895.61	631.87
1113	E2	706.35	6,156.08	720.00	7,582.43	1,895.61	631.87
1114	B	1,274.01	11,103.34	1,080.00	13,457.35	3,364.34	1,121.45
1115	Fa	706.35	6,156.08	720.00	7,582.43	1,895.61	631.87
1116	F	729.47	6,357.56	720.00	7,807.03	1,951.76	650.59
1117	F2	729.47	6,357.56	720.00	7,807.03	1,951.76	650.59
1118	F	729.47	6,357.56	720.00	7,807.03	1,951.76	650.59
1119	C2	1,086.50	9,469.18	720.00	11,275.68	2,818.92	939.64
1201	Db	778.27	6,782.89	720.00	8,281.16	2,070.29	690.10
1202	D	737.18	6,424.71	720.00	7,881.89	1,970.47	656.82
1203	D	737.18	6,424.71	720.00	7,881.89	1,970.47	656.82
1204	D	737.18	6,424.71	720.00	7,881.89	1,970.47	656.82
1205	D	737.18	6,424.71	720.00	7,881.89	1,970.47	656.82
1206	D	737.18	6,424.71	720.00	7,881.89	1,970.47	656.82
1207	D1	1,298.41	11,316.00	1,080.00	13,694.41	3,423.60	1,141.20
1209	A	1,044.12	9,099.81	1,080.00	11,223.93	2,805.98	935.33
1210	E2	706.35	6,156.08	720.00	7,582.43	1,895.61	631.87
1211	E	706.35	6,156.08	720.00	7,582.43	1,895.61	631.87
1212	E	706.35	6,156.08	720.00	7,582.43	1,895.61	631.87
1213	E2	706.35	6,156.08	720.00	7,582.43	1,895.61	631.87
1214	B	1,274.01	11,103.34	1,080.00	13,457.35	3,364.34	1,121.45
1215	Fa	706.35	6,156.08	720.00	7,582.43	1,895.61	631.87
1216	F	729.47	6,357.56	720.00	7,807.03	1,951.76	650.59
1217	F2	729.47	6,357.56	720.00	7,807.03	1,951.76	650.59
1218	F	729.47	6,357.56	720.00	7,807.03	1,951.76	650.59
1219	C2	1,086.50	9,469.18	720.00	11,275.68	2,818.92	939.64
1401	Db	778.27	6,782.89	720.00	8,281.16	2,070.29	690.10
1402	D	737.18	6,424.71	720.00	7,881.89	1,970.47	656.82
1403	D	737.18	6,424.71	720.00	7,881.89	1,970.47	656.82
1404	D	737.18	6,424.71	720.00	7,881.89	1,970.47	656.82
1405	D	737.18	6,424.71	720.00	7,881.89	1,970.47	656.82
1406	D	737.18	6,424.71	720.00	7,881.89	1,970.47	656.82
1407	D1	1,298.41	11,316.00	1,080.00	13,694.41	3,423.60	1,141.20
1409	A	1,044.12	9,099.81	1,080.00	11,223.93	2,805.98	935.33
1410	E2	706.35	6,156.08	720.00	7,582.43	1,895.61	631.87
1411	E	706.35	6,156.08	720.00	7,582.43	1,895.61	631.87
1412	E	706.35	6,156.08	720.00	7,582.43	1,895.61	631.87
1413	E2	706.35	6,156.08	720.00	7,582.43	1,895.61	631.87
1414	B	1,274.01	11,103.34	1,080.00	13,457.35	3,364.34	1,121.45
1415	Fa	706.35	6,156.08	720.00	7,582.43	1,895.61	631.87

Unit	Type	Condominium Association	Hotel Shared Costs	Amenity Fee	Total Annual Assessment	Total Quarterly Assessment	Total Monthly Assessment
1416	F	729.47	6,357.56	720.00	7,807.03	1,951.76	650.59
1417	F2	729.47	6,357.56	720.00	7,807.03	1,951.76	650.59
1418	F	729.47	6,357.56	720.00	7,807.03	1,951.76	650.59
1419	C2	1,086.50	9,469.18	720.00	11,275.68	2,818.92	939.64
1501	Db	778.27	6,782.89	720.00	8,281.16	2,070.29	690.10
1502	D	737.18	6,424.71	720.00	7,881.89	1,970.47	656.82
1503	D	737.18	6,424.71	720.00	7,881.89	1,970.47	656.82
1504	D	737.18	6,424.71	720.00	7,881.89	1,970.47	656.82
1505	D	737.18	6,424.71	720.00	7,881.89	1,970.47	656.82
1506	D	737.18	6,424.71	720.00	7,881.89	1,970.47	656.82
1507	D1	1,298.41	11,316.00	1,080.00	13,694.41	3,423.60	1,141.20
1509	A	1,044.12	9,099.81	1,080.00	11,223.93	2,805.98	935.33
1510	E2	706.35	6,156.08	720.00	7,582.43	1,895.61	631.87
1511	E	706.35	6,156.08	720.00	7,582.43	1,895.61	631.87
1512	E	706.35	6,156.08	720.00	7,582.43	1,895.61	631.87
1513	E2	706.35	6,156.08	720.00	7,582.43	1,895.61	631.87
1514	B	1,274.01	11,103.34	1,080.00	13,457.35	3,364.34	1,121.45
1515	Fa	706.35	6,156.08	720.00	7,582.43	1,895.61	631.87
1516	F	729.47	6,357.56	720.00	7,807.03	1,951.76	650.59
1517	F2	729.47	6,357.56	720.00	7,807.03	1,951.76	650.59
1518	F	729.47	6,357.56	720.00	7,807.03	1,951.76	650.59
1519	C2	1,086.50	9,469.18	720.00	11,275.68	2,818.92	939.64
1601	Db	778.27	6,782.89	720.00	8,281.16	2,070.29	690.10
1602	D	737.18	6,424.71	720.00	7,881.89	1,970.47	656.82
1603	D	737.18	6,424.71	720.00	7,881.89	1,970.47	656.82
1604	D	737.18	6,424.71	720.00	7,881.89	1,970.47	656.82
1605	D	737.18	6,424.71	720.00	7,881.89	1,970.47	656.82
1606	D	737.18	6,424.71	720.00	7,881.89	1,970.47	656.82
1607	D1	1,298.41	11,316.00	1,080.00	13,694.41	3,423.60	1,141.20
1609	A	1,044.12	9,099.81	1,080.00	11,223.93	2,805.98	935.33
1610	E2	706.35	6,156.08	720.00	7,582.43	1,895.61	631.87
1611	E	706.35	6,156.08	720.00	7,582.43	1,895.61	631.87
1612	E	706.35	6,156.08	720.00	7,582.43	1,895.61	631.87
1613	E2	706.35	6,156.08	720.00	7,582.43	1,895.61	631.87
1614	B	1,274.01	11,103.34	1,080.00	13,457.35	3,364.34	1,121.45
1615	Fa	706.35	6,156.08	720.00	7,582.43	1,895.61	631.87
1616	F	729.47	6,357.56	720.00	7,807.03	1,951.76	650.59
1617	F2	729.47	6,357.56	720.00	7,807.03	1,951.76	650.59
1618	F	729.47	6,357.56	720.00	7,807.03	1,951.76	650.59
1619	C2	1,086.50	9,469.18	720.00	11,275.68	2,818.92	939.64
1701	Db	778.27	6,782.89	720.00	8,281.16	2,070.29	690.10
1702	D	737.18	6,424.71	720.00	7,881.89	1,970.47	656.82
1703	D	737.18	6,424.71	720.00	7,881.89	1,970.47	656.82
1704	D	737.18	6,424.71	720.00	7,881.89	1,970.47	656.82
1705	D	737.18	6,424.71	720.00	7,881.89	1,970.47	656.82
1706	D	737.18	6,424.71	720.00	7,881.89	1,970.47	656.82
1707	D1	1,298.41	11,316.00	1,080.00	13,694.41	3,423.60	1,141.20
1709	A	1,044.12	9,099.81	1,080.00	11,223.93	2,805.98	935.33
1710	E2	706.35	6,156.08	720.00	7,582.43	1,895.61	631.87
1711	E	706.35	6,156.08	720.00	7,582.43	1,895.61	631.87
1712	E	706.35	6,156.08	720.00	7,582.43	1,895.61	631.87
1713	E2	706.35	6,156.08	720.00	7,582.43	1,895.61	631.87
1714	B	1,274.01	11,103.34	1,080.00	13,457.35	3,364.34	1,121.45
1715	Fa	706.35	6,156.08	720.00	7,582.43	1,895.61	631.87
1716	F	729.47	6,357.56	720.00	7,807.03	1,951.76	650.59
1717	F2	729.47	6,357.56	720.00	7,807.03	1,951.76	650.59
1718	F	729.47	6,357.56	720.00	7,807.03	1,951.76	650.59
1719	C2	1,086.50	9,469.18	720.00	11,275.68	2,818.92	939.64
1801	Db	778.27	6,782.89	720.00	8,281.16	2,070.29	690.10
1802	D	737.18	6,424.71	720.00	7,881.89	1,970.47	656.82
1803	D	737.18	6,424.71	720.00	7,881.89	1,970.47	656.82
1804	D	737.18	6,424.71	720.00	7,881.89	1,970.47	656.82
1805	D	737.18	6,424.71	720.00	7,881.89	1,970.47	656.82
1806	D	737.18	6,424.71	720.00	7,881.89	1,970.47	656.82
1807	D1	1,298.41	11,316.00	1,080.00	13,694.41	3,423.60	1,141.20

Unit	Type	Condominium Association	Hotel Shared Costs	Amenity Fee	Total Annual Assessment	Total Quarterly Assessment	Total Monthly Assessment
1809	A2	1,370.33	11,942.80	1,080.00	14,393.13	3,598.28	1,199.43
1810	E	706.35	6,156.08	720.00	7,582.43	1,895.61	631.87
1811	E	706.35	6,156.08	720.00	7,582.43	1,895.61	631.87
1812	B2	1,582.23	13,789.63	1,080.00	16,451.86	4,112.97	1,370.99
1813	Fa	706.35	6,156.08	720.00	7,582.43	1,895.61	631.87
1814	F	729.47	6,357.56	720.00	7,807.03	1,951.76	650.59
1815	F2	729.47	6,357.56	720.00	7,807.03	1,951.76	650.59
1816	F	729.47	6,357.56	720.00	7,807.03	1,951.76	650.59
1817	C2	1,086.50	9,469.18	720.00	11,275.68	2,818.92	939.64
1901	Db	778.27	6,782.89	720.00	8,281.16	2,070.29	690.10
1902	D	737.18	6,424.71	720.00	7,881.89	1,970.47	656.82
1903	D	737.18	6,424.71	720.00	7,881.89	1,970.47	656.82
1904	D	737.18	6,424.71	720.00	7,881.89	1,970.47	656.82
1905	D	737.18	6,424.71	720.00	7,881.89	1,970.47	656.82
1906	D	737.18	6,424.71	720.00	7,881.89	1,970.47	656.82
1907	D1	1,296.41	11,316.00	1,080.00	13,694.41	3,423.60	1,141.20
1909	A2	1,370.33	11,942.80	1,080.00	14,393.13	3,598.28	1,199.43
1910	E	706.35	6,156.08	720.00	7,582.43	1,895.61	631.87
1911	E	706.35	6,156.08	720.00	7,582.43	1,895.61	631.87
1912	B2	1,582.23	13,789.63	1,080.00	16,451.86	4,112.97	1,370.99
1913	Fa	706.35	6,156.08	720.00	7,582.43	1,895.61	631.87
1914	F	729.47	6,357.56	720.00	7,807.03	1,951.76	650.59
1915	F2	729.47	6,357.56	720.00	7,807.03	1,951.76	650.59
1916	F	729.47	6,357.56	720.00	7,807.03	1,951.76	650.59
1917	C2	1,086.50	9,469.18	720.00	11,275.68	2,818.92	939.64
Hotel Unit	Commercial	203,056.41	-	-	203,056.41	50,764.10	16,921.37
Total		\$ 451,512.00	\$ 2,165,363.34	\$ 229,080.00	\$ 2,842,955.34	\$ 710,738.83	\$ 236,912.95

Exhibit "C"

FONTAINEBLEAU III OCEAN CLUB CONDOMINIUM

PURCHASE AGREEMENT

ORAL REPRESENTATIONS CANNOT BE RELIED UPON AS CORRECTLY STATING THE REPRESENTATIONS OF THE DEVELOPER. FOR CORRECT REPRESENTATIONS, REFERENCE SHOULD BE MADE TO THIS CONTRACT AND THE DOCUMENTS REQUIRED BY SECTION 718.503, FLORIDA STATUTES, TO BE FURNISHED BY A DEVELOPER TO A BUYER OR LESSEE.

ANY PAYMENT IN EXCESS OF 10 PERCENT OF THE PURCHASE PRICE MADE TO DEVELOPER PRIOR TO CLOSING PURSUANT TO THIS CONTRACT MAY BE USED FOR CONSTRUCTION PURPOSES BY THE DEVELOPER.

Additionally, under certain circumstances more particularly described in paragraph 4, and provided that the Developer has posted "Alternative Assurances" with the Division of Florida Land Sales, Condominiums and Mobile Homes, Seller may use all of Buyer's deposits (including those equal to the initial 10% of the purchase price for construction purposes).

In this Agreement, the term "Buyer" and/or "Purchaser" means or refers to the buyer or buyers listed below who have signed this Agreement. The word "Seller" and/or "Developer" means or refers to FONTAINEBLEAU FLORIDA TOWER 3, LLC, a Florida limited liability company, and its successors and/or assigns.

If the first letter of a word is capitalized in this Agreement, that word will have the meaning given to it in this Agreement or, if no definition is given in this Agreement, then in the Declaration (as defined in paragraph 1 of this Agreement).

Buyer(s): _____

Address: _____

City: _____ State: _____

Country: _____ Zip Code: _____

Home Phone: (____) _____ Office Phone: (____) _____

Tax I.D. No.: _____ Fax. No. (____) _____

E-Mail: _____

1. Purchase and Sale. Buyer agrees to buy, and Seller agrees to sell (on the terms and conditions contained in this Agreement), Unit _____ (the "Unit") in the proposed FONTAINEBLEAU III OCEAN CLUB CONDOMINIUM (the "Condominium"). The Unit and the Condominium are described in greater detail in the proposed Declaration of Condominium (the "Declaration") included in the Prospectus and attached exhibits (the "Condominium Documents"). Buyer acknowledges receipt of the Condominium Documents and all documents required by Section 718.503, Florida Statutes, to be furnished by a developer to a Buyer, on or before the date of this Agreement. The foregoing statement shall not, however, be in lieu of the execution of a Receipt for Condominium Documents.

Inasmuch as the Condominium Property is intended to be operated as part of a hotel, Seller reserves the right, in its sole discretion, to rent out the Unit prior to closing. As such, at the time of closing, the Unit may be delivered subject to the possessory rights of any hotel guest then occupying the Unit (and Buyer agrees to accept title to the Unit subject to such possessory rights.) Inasmuch as Seller has reserved the right to rent out the Unit prior to closing, Buyer is hereby advised that, at the time of closing, THE UNIT MAY HAVE BEEN PREVIOUSLY OCCUPIED.

.2. Payment of the Purchase Price. The total purchase price for the Unit is \$ _____ (the "Purchase Price"). Buyer agrees to make the following payments against the Purchase Price:

Buyer's Initials:

Seller's Initials

<u>Payment</u>	<u>Due Date</u>	<u>Amount</u>
Initial deposit	Upon Buyer's execution of this Agreement	\$ _____
Additional Deposit	_____	\$ _____
Additional Deposit	_____	\$ _____
Additional Deposit	_____	\$ _____
Additional Deposit	_____	\$ _____
Balance	Closing	\$ _____
Total Purchase Price		\$ _____

Deposits may be made by personal check (subject to clearance), cashier's check or wire transfer of federal funds. **The balance due at closing must be paid by bank cashier's check or wire transfer of federal funds.** All payments must be made in United States funds and all checks must be payable on a bank located in the Continental United States. Even though Seller is not obligated to do so, if Seller accepts a deposit from Buyer by credit card and/or drawn on a foreign bank and/or payable in a currency other than U.S. currency, Buyer shall be solely responsible for all costs of collection and/or conversion and agrees to pay same to Seller promptly upon demand or, in Seller's sole and absolute discretion, Seller may permit such costs to be charged to Buyer at the time of closing. If Buyer fails to pay any deposit on time, and Seller agrees to accept it on a later date (which Seller is not obligated to do), Buyer will pay a late funding charge equal to interest at the rate of eighteen percent (18%) per annum from the date due until the date received and cleared by Seller.

Buyer also agrees to pay all costs and other sums required to be paid by Buyer in this Agreement (many of which are more particularly described in paragraph 11 below).

3. How Buyer Pays. Buyer understands and agrees that Buyer will be obligated to pay "all cash" at closing. This Agreement and Buyer's obligations under this Agreement to purchase the Unit will not depend on whether or not Buyer qualifies for or obtains a mortgage from any lender. Buyer will be solely responsible for making Buyer's own financial arrangements. Seller agrees, however, to cooperate with any lender Buyer chooses and to coordinate closing with such lender, if, but only if, such lender meets Seller's closing schedule and pays Seller the proceeds of its mortgage at closing. Notwithstanding any cooperation provided by Seller, nothing herein shall be deemed to qualify or otherwise condition Buyer's obligation to close "all cash" on the purchase of the Unit.

Although Seller does not have to do so, if Seller agrees to delay closing until Buyer's lender is ready, or to wait for funding from Buyer's lender until after closing, or to accept a portion of the sums due at closing in the form of a personal check, Buyer agrees to pay Seller a late funding charge equal to interest, at the rate of eighteen percent (18%) per annum, on all funds due Seller which have not then been paid to Seller (and, with regard to personal checks, which have not then cleared) from the date Seller originally scheduled closing to the date of actual payment (and, with regard to personal checks, to the date of final clearance). This late funding charge may be estimated and charged by Seller at closing. Seller's estimate will be adjusted after closing based on actual funding and clearance dates upon either Seller's or Buyer's written request. In the event that Seller does not receive immediately cleared funds at closing, Buyer will not be allowed to take possession of the Unit until Seller actually receives the funds and they have cleared. The foregoing paragraph will survive (continue to be effective after) closing.

4. Deposits. Except as permitted below or by the provisions of the Florida Condominium Act, all of Buyer's deposits will be held in escrow by Chicago Title Insurance Company ("Escrow Agent"), with offices at 2701 Gateway Drive, Pompano Beach, Florida 33069, in accordance with the escrow agreement contained in the Condominium Documents. The escrow agreement is incorporated into this Agreement as if repeated at length here, and Buyer agrees that the deposits may be held in any depository which meets the requirements of the Act, including, without limitation, a financial institution chartered and located out of the State of Florida.

Buyer agrees that all of Buyer's deposits in excess of ten percent (10%) of the Purchase Price may be used by Seller for construction and development purposes as permitted by law. Additionally, Seller intends to use Buyer's deposits up to ten percent (10%) of the Purchase Price as and to the extent permitted by applicable law. Accordingly, if Seller has obtained or obtains the approval of the Director of the Division of Florida Land Sales, Condominiums and Mobile Homes to provide "Alternative Assurances", as permitted by law, in lieu of holding deposits up to ten percent (10%) of the Purchase Price in escrow, Seller may cause the Escrow Agent to disburse such deposits to it for all uses permitted by law. If Seller has obtained such approval as of the date of this Agreement, a copy of the Escrow Agreement providing the mechanism for such disbursement has been delivered to Buyer. If such approval is obtained after the date of this Agreement, Buyer will be provided with a copy of the Escrow Agreement, but Buyer agrees that it shall not be deemed a material or adverse change in the offering of the

Buyer's Initials:

Purchase Agreement

Seller's Initials

Condominium by reason of the fact that Buyer has already agreed to the use of Buyer's deposits up to ten percent (10%) of the Purchase Price in the manner stated above.

If Buyer so requests, Buyer may obtain a receipt for Buyer's deposits from the Escrow Agent. Seller may change escrow agents (as long as the new escrow agent is authorized to be an escrow agent under applicable Florida law), in which case Buyer's deposits (and any interest actually earned on them) may be transferred to the new escrow agent at Seller's direction.

At closing, all deposits not previously disbursed to Seller will be released to Seller. If Buyer defaults, Seller is entitled to retain all deposits (and any interest actually earned on them) and terminate this Agreement. If Buyer properly terminates this Agreement in the manner allowed in this Agreement or by applicable law, all deposits (and any interest actually earned on them) will be returned to Buyer within thirty (30) days after the effective date of Buyer's cancellation, or the date Buyer's deposit check(s) clears, if later. Except where expressly provided herein to the contrary or otherwise required by law, all interest earned on Buyer's deposits shall accrue solely to the benefit of Seller, and shall not be credited against the Purchase Price of the Unit. Buyer further understands and agrees that to the extent that deposit monies are used as permitted hereby, said monies are not available for investment and accordingly no interest shall be earned or deemed to be earned (even if Seller indirectly benefits from the use of said funds). No interest will be assumed to be earned, unless in fact said sums are invested in an interest bearing account and do in fact earn interest.

5. Seller's Financing. Seller may borrow money from lenders for the acquisition, development and/or construction of the Condominium. Buyer agrees that any lender advancing funds for Seller's use in connection with the Condominium will have a prior mortgage on the Unit and the Condominium until closing. At that time, Seller shall cause the then applicable mortgages to be released as an encumbrance against the Unit and may use Buyer's closing proceeds for such purpose. Neither this Agreement, nor Buyer's payment of deposits, will give Buyer any lien or claim against the Unit, the Condominium or the real property upon which the Condominium is being developed. Without limiting the generality of the foregoing, Buyer's rights under this Agreement will be subordinate to all mortgages (and all modifications made to those mortgages) affecting the Unit, the Condominium or the real property upon which the Condominium is being developed, even if those mortgages (or modifications) are made or recorded after the date of this Agreement.

6. Insulation; Energy Efficiency. Seller has advised Buyer, as required by the rules of the Federal Trade Commission, that it intends, currently, to install in connection with the Unit, the following insulation: (a) 3/4" rigid insulation on the walls, having an R-Value of R-5; and (b) 2 1/2" rigid insulation on the roof, having an R-Value of R-11. This R-value information is based solely on the information given by the appropriate manufacturers and Buyer agrees that Seller is not responsible for the manufacturers' errors.

To the extent required by applicable law, each buyer may have the Condominium building's energy efficiency rating determined. In accordance with the provisions of applicable law, upon the completion and certification of an energy performance level display card for the Condominium building, such card shall be forwarded to the Buyer and deemed incorporated in this Agreement. Buyer acknowledges receipt of the Department of Community Affairs' brochure regarding energy efficiency ratings.

All insulation and energy efficiency rating information is subject to Seller's general right, under paragraphs 14, 28 and 31, to make changes in Seller's Plans and Specifications, and to applicable limitations of Seller's liability to Buyer.

7. Completion Date: Presale Contingency. Seller estimates it will substantially complete construction of the Unit, in the manner specified in this Agreement, by July 31, 2007, subject only to extensions resulting from "Force Majeure" (as same may be extended by Force Majeure, the "Outside Date"). The term "Force Majeure" as used in this Agreement shall mean "Acts of God", labor disputes (whether lawful or not), material or labor shortages, restrictions by any governmental or utility authority, civil riots, floods or other causes beyond Seller's control. Notwithstanding the foregoing or any other contrary provision of this Agreement, Seller shall have the right to cancel this Agreement and cause Buyer's deposits to be refunded in the event that Seller does not enter into binding contracts to sell at least seventy five percent (75%) of the Units in the Condominium. Seller must, however, notify Buyer of such a termination within one (1) year following the date of this Agreement, otherwise Seller will be required to construct the Condominium and the Unit and otherwise proceed to perform its obligations under this Agreement. The foregoing presale contingency is a provision solely for the benefit of Seller, and may be waived unilaterally by Seller. Accordingly, Seller may elect to proceed with the construction of the Condominium and to remain bound by the terms of this Agreement, whether or not the stated presales threshold has been met. In the event that Seller does elect to proceed without having met the threshold, Buyer will have no right to object thereto and shall remain bound by the terms of this Agreement. This paragraph shall not delay the effectiveness of this Agreement, which shall be immediate, but, rather, shall be deemed a "condition subsequent" to this Agreement. In the event of Seller's termination of this Agreement pursuant to this paragraph, upon such termination and the return of Buyer's deposits, Seller and Buyer will be fully relieved and released from all obligations and liabilities under and in connection with this Agreement. Seller agrees to use its good efforts to meet the foregoing pre-sale requirement.

8. Inspection Prior to Closing. Buyer will be given an opportunity prior to closing, on the date and at the time scheduled by Seller to inspect the Unit with Seller's representative. At that time, Buyer will sign an

Buyer's Initials:

Purchase Agreement

Seller's Initials

inspection statement listing any defects in workmanship or materials (only within the boundaries of the Unit itself) which Buyer discovers. If any item listed is actually defective in workmanship or materials in Seller's opinion (keeping in mind the construction standards applicable in Miami-Dade County, Florida for similar property), Seller will be obligated to correct those defects at its cost within a reasonable period of time after closing, but Seller's obligation to correct will not be grounds for deferring the closing, nor for imposing any condition on closing. No escrows or holdbacks of closing funds will be permitted. Buyer understands and agrees that Seller's obligation to correct defects in the Unit noted during the pre-closing inspection shall automatically terminate (with Seller having no further obligations for the repair of such items) upon the earlier of: (i) the date that Buyer obtains a permit for construction and/or improvement of the Unit, or (ii) the date that Buyer commences construction and/or improvement of the Unit, whether or not a permit has been obtained. If Buyer fails to take advantage of the right to a pre-closing inspection on the date and time scheduled, Seller will not be obligated to reschedule an inspection prior to closing and Buyer shall be deemed to have accepted the Unit in its AS-IS condition.

From and after the closing, Buyer hereby grants Seller and its agents access to the Unit at reasonable times during normal business hours to complete any necessary repairs to the Unit. If Buyer cannot be present at the time such work is to be performed to facilitate completion of such work, Buyer hereby authorizes Seller, its agents, employees and contractors to enter the Unit for such purposes using a master key or a key maintained by the Association. If Buyer cannot or elects not to be present at the time that Seller performs any such work, Buyer hereby waives and releases Seller (its partners, contractors, subcontractors, employees, agents, designees and assigns) from any and all claims that Buyer may have against Seller (its partners, contractors, subcontractors, employees, agents, designees and assigns) relating to damage to or theft of property from the Unit that is not due to the negligence or intentional act of Seller or its partners, contractors, subcontractors, employees, agents, designees and/or assigns. Seller shall have no further obligation to complete punch list items if Seller has submitted three (3) written requests to Buyer for entry over a thirty (30) day period after closing, and access to the Unit has been denied for any reason.

Buyer acknowledges that all matters pertaining to the initial construction of the Unit will be handled by Seller and Seller's representatives. Buyer agrees not to interfere with or interrupt any workers at the site of the Unit. No personal inspections (other than the one pre-closing inspection) will be permitted. Buyer may not commence any work on the Unit, other than prepaid options or extras that Seller agrees in writing to provide, until after closing. Buyer recognizes that Seller is not obligated to agree to provide extras or options.

Buyer can examine Seller's Plans and Specifications at Seller's business office, located on site during regular business hours by making an appointment to do so in advance.

9. Closing Date. Buyer understands and agrees that Seller has the right to schedule the date, time and place for closing, which shall in no event be later than six (6) months following the Outside Date. Before Seller can require Buyer to close, however, two things must be done:

(a) Seller must record the Declaration and related documents in the Miami-Dade County public records; and

(b) Seller must obtain a temporary, partial or permanent certificate of occupancy for or covering the Unit from the proper governmental agency (a certificate of occupancy is the official approval needed before a unit may be lived in), but, subject and subordinate to the provisions of paragraphs 8 and 27 of this Agreement (without limiting the generality of those provisions by this specific reference), the Common Elements, the Shared Components and other portions of the Condominium Property need not then have certificates of occupancy, nor be completed, provided, however, that the certification of substantial completion described in Section 718.104(4)(e), Florida Statutes, shall be included as an exhibit to the Declaration, as recorded. Seller does, however, agree to complete those amenities, roads, streets and facilities for water, sewer, gas, and electric service within a reasonable time following closing and otherwise in accordance with the terms of the Property Report dated as of _____.

Buyer will be given at least ten (10) days' notice of the date, time and place of closing. Seller is authorized to postpone the closing for any reason and Buyer will close on the new date, time and place specified in a notice of postponement (as long as at least three (3) days' notice of the new date, time and place is given). A change of time or place of closing only (one not involving a change of date) will not require any additional notice period. Any formal notice of closing, postponement or rescheduling may be given by Seller orally, by telephone, telegraph, telex, telecopy, mail or other reasonable means of communication at Seller's option. All of these notices will be sent or directed to the address, or given by use of the information specified on Page 1 of this Agreement unless Seller has received written notice from Buyer of any change prior to the date the notice is given. These notices will be effective on the date given or mailed (as appropriate). An affidavit of one of Seller's employees or agents stating that this notice was given or mailed will be conclusive.

After the notice is given or mailed, and if requested in writing by Buyer, Seller will send a written confirmation of the closing, together with a draft closing statement and other pertinent information and instructions. This written confirmation is given merely as a courtesy and is not the formal notice to close. Accordingly, it does not need to be received by any particular date prior to closing. Buyer agrees, however, to follow all instructions given in any formal notice and written confirmation.

Buyer's Initials:

Purchase Agreement

Seller's Initials

If Buyer fails to receive any of these notices or the confirmation because Buyer failed to advise Seller of any change of address or phone, telecopy or telex number, because Buyer has failed to pick up a letter when Buyer has been advised of an attempted delivery or because of any other reason, Buyer will not be relieved of Buyer's obligation to close on the scheduled closing date unless Seller agrees in writing to postpone the scheduled date.

If Seller agrees in writing to reschedule closing at Buyer's request, or if Buyer is a corporation or other entity and Buyer fails to produce the necessary documentation Seller requests and, as a result, closing is delayed, or if closing is delayed for any other reason (except for a delay desired, requested or caused by Seller), Buyer agrees to pay at closing a late funding charge equal to interest, at the rate of eighteen percent (18%) per annum, on that portion of the purchase price not then paid to Seller (and cleared), from the date Seller originally scheduled closing to the date of actual closing. Except only as may result from delays desired, requested or caused by Seller, all prorations will be made as of the originally scheduled date. **Buyer understands that Seller is not required to reschedule or to permit a delay in closing at Buyer's request.**

10. Closing. The term "closing" refers to the time when Seller delivers the deed to the Unit to Buyer and ownership changes hands. Buyer's ownership is referred to as "title". Seller promises that the title Buyer will receive at closing will be good, marketable and insurable (subject to the permitted exceptions listed or referred to below). Notwithstanding that Buyer is obligated to pay "all-cash" hereunder, in the event that Buyer obtains a loan for any portion of the Purchase Price, Buyer shall have the right to obtain a title insurance commitment and policy for the Unit from its own sources rather than to receive same from Seller, or Buyer may elect to have Seller's closing agent issue the title insurance commitment and policy, in accordance with terms set forth in paragraph 11 below.

In the event that Buyer elects to obtain a title insurance commitment and policy for the Unit from its own sources rather than to receive same from Seller, (i) Buyer shall provide Seller with written notice of same five (5) business days prior to the originally scheduled closing date, (ii) Seller shall have no obligation to provide a title insurance commitment or policy, or any other evidence of title to Buyer and (iii) Buyer shall, no later than five (5) business days prior to closing (the "Objection Deadline"), notify Seller in writing if title is not in the condition required by this Agreement and specify in detail any defect (i.e., any matters which make title other than in the condition pursuant to which same is required to be conveyed to Buyer), provided that if Buyer fails to give Seller written notice of defect(s) before the expiration of the Objection Deadline, the defects shall, anything in this Agreement notwithstanding, be deemed to be waived as title objections to closing this transaction and Seller shall be under no obligation whatsoever to take any corrective action with respect to same, and title to the Unit shall be conveyed subject to same.

Buyer will receive two (2) documents at closing which Buyer agrees to accept as proof that Buyer's title is as represented above:

(a) A written commitment, whether provided by Seller's closing agent or otherwise, from a title insurance company licensed in Florida agreeing to issue a policy insuring title or the policy itself. This commitment (or policy) will list any exceptions to title. Permitted exceptions (exceptions which Buyer agrees to take title subject to) are:

- (i) Liability for all taxes or assessments affecting the Unit starting the year Buyer receives title and continuing thereafter;
- (ii) All laws, and all restrictions, covenants, conditions, limitations, agreements, reservations and easements now or hereafter recorded in the public records, which may include, without limitation, zoning restrictions, property use limitations and obligations, easements (rights-of-way) and agreements relating to telephone lines, water and sewer lines and other utilities;
- (iii) The restrictions, covenants, conditions, easements, terms and other provisions imposed by the documents contained or referred to in the Condominium Documents (and any other documents which Seller, in its sole discretion, believes to be necessary or appropriate) and the Declaration of Restrictions and Reciprocal Easement Agreement (the "Easement Agreement") which are recorded, now or at any time after the date of this Agreement, in the public records;
- (iv) Pending governmental liens for public improvements as of closing (Seller will be responsible, however, for certified governmental liens for public improvements as of closing; provided, however, that to the extent that any such certified liens are payable in installments, Seller shall only be responsible for those payments and/or installments due prior to closing, and Buyer hereby assumes all payments and/or installments coming due after closing);
- (v) Standard exceptions for water-front property and artificially filled-in property which once was in navigable waters and all other standard exceptions for similar property;
- (vi) All standard printed exceptions contained in an ALTA Owner's title insurance policy issued in Miami-Dade County, Florida; and
- (vii) Any matters not listed above as long as affirmative title insurance is given for these matters.

Buyer's Initials:

Purchase Agreement

Seller's Initials

(b) A Special Warranty Deed. At closing, Seller promises to give Buyer a special warranty deed to the Unit. The special warranty deed will be subject to (that is, contain exceptions for) all of the matters described above.

Buyer will also receive at closing a bill of sale for any appliances or furnishings included in the Unit and Seller's form of owner's ("no lien") affidavit and FIRPTA (non-foreign) affidavit. When Buyer receives the special warranty deed at closing, Buyer will sign Seller's closing agreement, a settlement statement and all papers that Seller deems reasonably necessary or appropriate.

If Seller cannot provide the quality of title described above, Seller will have a reasonable period of time (at least sixty (60) days) to correct any defects in title. If Seller cannot, after making reasonable efforts to do so (which shall not require the bringing of lawsuits or the payment or satisfaction of involuntary liens or judgments) correct the title defects, Buyer will have two options:

1. Buyer can accept title in the condition Seller offers it (with defects) and pay the full Purchase Price for the Unit with exceptions for such title matters to be contained in the special warranty deed for the Unit. Buyer will not make any claims against Seller because of the defects; or
2. Buyer can cancel this Agreement and receive a full refund of Buyer's deposits. Seller will be relieved of all obligations under this Agreement (and otherwise) when Seller refunds the deposits to Buyer.

At the same time Buyer receives the special warranty deed, Buyer agrees to pay the balance of the Purchase Price and any additional amounts owed under this Agreement. Until all sums have been received and cleared, Seller will be entitled to a vendor's lien on the Unit (which Buyer agrees Seller may unilaterally record in the Public Records of the County). This paragraph shall survive closing.

11. Additional Costs and Development Fee. Buyer understands and agrees that, in addition to the Purchase Price for the Unit, Buyer must pay certain other fees, costs or other sums when the title is delivered to Buyer at closing. These include:

- (a) A "development fee" equal to one and three quarters percent (1.75%) of the Purchase Price (and of any charges for options or extras now or hereafter contracted for which are not included in the Purchase Price). This fee will be used, in part, to pay for the following closing costs: (i) the costs of officially recording the deed in the Public Records of the County (currently, recording fees are \$10.00 for the first page of an instrument and \$8.50 for each additional page), (ii) the documentary stamp taxes payable in connection with the deed conveying the Unit to Buyer (currently, documentary stamp taxes are \$.60 for each \$100.00 of consideration), and (iii) for the premium on the owner's title insurance policy, at the minimum promulgated risk rates promulgated by the Florida Insurance Commissioner (taking into account applicable reissue rates and new home credits, if any), whether obtained from Seller's closing agent, or elsewhere. The balance of the "development fee" shall be retained by Seller to provide additional revenue and to offset certain of its construction and development expenses, including without limitation, certain of Seller's administration expenses and Seller's attorneys' fees in connection with development of the Condominium. Accordingly, Buyer understands and agrees that the development fee is not for payment of closing costs or settlement services (other than to the extent expressly provided above), but rather represents additional funds to Seller which are principally intended to provide additional revenue and to cover various out-of-pocket and internal costs and expenses of Seller associated with development of the Condominium. In the event that (i) any sales tax is imposed in connection with the subject transaction, (ii) there is an increase in either the minimum title insurance rates or in the documentary stamp tax rate, (iii) any interim services fee is imposed by any governmental authority, or (iv) any new governmental tax or charge on deeds is imposed, Buyer agrees to pay all such increases, surcharges or new taxes or charges, in addition to the development fee;
- (b) The surtax, if any payable in connection with the conveyance of the Unit (presently, surtax is \$.45 for each \$100.00 of consideration);
- (c) Working capital contributions in an amount equal to the aggregate of two (2) times the regular monthly assessment for the Unit due the Condominium Association as determined at the time of closing and two (2) times the regular monthly allocated amount for the Unit due the Hotel Unit Owner with respect to the Hotel Shared Costs as determined at the time of closing. These charges will not be credited against regular assessments or charges, with respect to the contribution for the Hotel Shared Costs, shall be payable directly to the Hotel Unit Owner and may be used to pay any deficits or other sums the Hotel Unit Owner or any of its affiliates may be required to pay.
- (d) Any and all sales tax due in connection with the acquisition of any furnishings, finishes and/or equipment.

Buyer's Initials:

Purchase Agreement

Seller's Initials

- (e) A reimbursement to Seller for any utility, cable or interactive communication deposits or hook-up fees which Seller may have advanced prior to closing for the Unit. The amount of this charge is now unknown.
- (f) The remaining balance, if any, of any charges for options or upgrading of standard items included, or to be included, in the Unit as agreed to in writing by both Buyer and Seller.
- (g) Reimbursement to Seller, and/or Seller's closing agents, for charges incurred in connection with coordinating closing with Buyer and/or Buyer's lender, including, without limitation, charges for messenger expenses, long distance telephone calls, photocopying expenses, telecopying charges and others. The amount of these charges is now unknown.
- (h) In the event that Seller allows any delay in closing (which it has no obligation to do) or any other change in closing (which it has no obligation to do), Seller may impose a "redraw fee" to reimburse Seller for any additional costs it incurs as a result of any such rescheduling or change.
- (i) A refundable damage deposit to offset any damages that may be caused during Buyer's move-in.
- (j) The late funding charges provided for elsewhere in this Agreement. The amount of any such charges is now unknown.

In addition, if Buyer obtains a loan for any portion of the Purchase Price, Buyer will be obligated to pay any loan fees, closing costs, escrows, appraisals, credit fees, lender's title insurance premiums, prepayments and all other expenses charged by any lender giving Buyer a mortgage, if applicable. Additionally, if Buyer obtains a loan and elects to have Seller's closing agent act as "loan" closing agent as well, Buyer agrees to pay, in addition to any other sums described in this Agreement, such closing agent an aggregate sum equal to \$795.00, for a simultaneously issued mortgagee's title insurance policy, the agent's title examination, title searching and closing services related to acting as "loan closing agent". In addition to that sum, Buyer shall be obligated to pay the premiums (at promulgated rate) for any title endorsements requested by Buyer's lender. Notwithstanding any of the references in this paragraph to coordinating closing with any lender that Buyer may elect to obtain, nothing herein shall be deemed to make the Agreement, or the Buyer's obligations under the Agreement, conditional or contingent in any manner on the Buyer obtaining a loan to finance any portion of the Purchase Price; it being the agreement of the Buyer that the Buyer shall be obligated to close "all cash".

Current expenses of the Unit (for example, taxes and governmental assessments, current monthly assessments of the Association and current monthly charges of the Hotel Shared Costs) will be prorated between Buyer and Seller as of the date of closing. Additionally, at closing, Buyer shall be obligated to prepay the next month's maintenance assessment to the Association and the next month's charge for the Hotel Shared Costs. These prepayments are in addition to Buyer's obligation to pay the working capital contributions, as described above. If taxes for the year of closing are assessed on the Condominium as a whole, Buyer shall pay Seller, at closing, the Unit's allocable share of those taxes (as estimated by Seller and subject to reparation when the actual tax bill is available) for the Unit from the date of closing through the end of the applicable calendar year of closing. If taxes for the year of closing are assessed on a unit-by-unit basis, Buyer and Seller shall prorate taxes as of the closing date based upon the actual tax bill, if available, or an estimate by Seller, if not available, with Buyer responsible for paying the full amount of the tax bill and Seller reimbursing Buyer for Seller's prorated share of those taxes. Buyer agrees that Seller's prorated share of the taxes due as of closing need not be paid to Buyer, however, until the actual tax bill is presented to Seller, and any proration based on an estimate of the current year's taxes shall be subject to reparation upon request of either party, provided, however, that (i) the actual amount of taxes is at least ten percent (10%) higher or lower than the estimate used for prorations, and (ii) any request for reparation is made within six (6) months following the issuance of the actual tax bill for the Unit (it being assumed, for purposes hereof, that tax bills are issued on November 1 of each tax year). No request for proration of amounts less than the threshold set forth above or made beyond the six (6) month period shall be valid or enforceable. In addition, Buyer shall pay, or reimburse Seller if then paid, for any interim proprietary and general services fee imposed by any governmental authority having jurisdiction over the Unit. This Subsection shall survive (continue to be effective after) closing.

12. Adjustments with the Association. Buyer understands that Seller may advance money to the Association to permit it to pay for certain of its expenses (for example, but without limitation, insurance premiums, common element utility and/or cable or other interactive communication charges and deposits, permit and license fees, charges for service contracts, salaries of employees of the Association and other similar expenses). Seller is entitled to be reimbursed by the Association for all of these sums advanced by Seller. The Association will reimburse Seller out of regular assessments paid by Buyer and other owners as those contributions and assessments are collected, or as otherwise requested by Seller. Seller also, at its election, may receive reimbursement for these payments by way of a credit against any sums it may become obligated to pay to the Association.

13. Default. If Buyer fails to perform any of Buyer's obligations under this Agreement (including making scheduled deposits and other payments) Buyer will be in "default". If Buyer is still in default twenty (20) days after Seller sends Buyer notice thereof, Seller shall be entitled to the remedies provided herein.

Buyer's Initials:

Purchase Agreement

Seller's Initials

Upon Buyer's default (and the expiration of any notice period, if applicable), all Buyer's rights under this Agreement will end and Seller can resell the Unit without any accounting to Buyer. Buyer understands that because Seller has taken the Unit off the market for Buyer, has spent money on sales, advertising, promotion and construction and has incurred other costs incident to this sale, Buyer's default will damage Seller. As compensation for this damage, in the event Seller cancels this Agreement because of Buyer's default, Buyer authorizes Seller (subject to the limitation provided below) to keep (or if not then paid by Buyer, Buyer will pay to Seller) all deposits and other pre-closing advance payments (including, without limitation, those on options, extras, upgrades and the like) Buyer has then made (and which would have been required to have been made had Buyer not defaulted) and all interest which was, or would have been, earned on them, all as liquidated damages (and not as a penalty). If Buyer defaults after fifteen percent (15%) of the Purchase Price, exclusive of interest, has been paid, Seller will refund to the Buyer any amount which remains from the payments Buyer made after subtracting fifteen percent (15%) of the Purchase Price, exclusive of interest. Any damage or loss that occurs to the Property while Buyer is in default will not affect Seller's right to liquidated damages.

If Seller defaults under this Agreement, Buyer will give Seller twenty (20) days' notice of it and if Seller has not cured the default within such period, Buyer will have such rights as may be available in equity and/or under applicable law, provided, however, that absent an intentional and willful default of Seller, Buyer shall not be permitted to seek to specifically enforce the Agreement.

This paragraph will survive (continue to be effective after) closing.

14. Construction Specifications. The Unit and the Condominium will be constructed in substantial accordance (in Seller's opinion) with the plans and specifications therefor kept in Seller's construction office, as such plans and specifications are amended from time to time. Seller may make such changes in the plans and specifications that it deems appropriate at any time, to accommodate its in the field construction needs (as more fully discussed in this paragraph 14) and in response to recommendations or requirements of local, state or federal governmental or quasi-governmental agencies or applicable utility and/or insurance providers. Such plans and specifications, as they are so amended, are referred to in this Agreement as "Seller's Plans and Specifications". Without limiting Seller's general right to make changes, Buyer specifically agrees that the changes described above and changes in the dimensions of rooms and balconies, in the location of windows, doors, walls, partitions, utility (including, but not limited to, television and telephone) lead-ins and outlets, air-conditioning equipment, ducts and components, lighting fixtures and electric panel boxes, and in the general layout of the Unit and Condominium, may be made by Seller in its discretion. In furtherance of the understanding and agreement stated above, Buyer acknowledges and agrees that it is a widely observed construction industry practice for pre-construction plans and specifications for any unit or building to be changed and adjusted from time to time in order to accommodate on-going, "in the field" construction needs. These changes and adjustments are essential in order to permit all components of the Unit and the Building to be integrated into a well-functioning and aesthetically pleasing product in an expeditious manner. Because of the foregoing, Buyer acknowledges and agrees that it is to Buyer's benefit to allow Seller the flexibility to make such changes in the Unit and the Condominium. Buyer further acknowledges and agrees that (i) the plans and specifications for the Unit and the Condominium on file with the applicable governmental authorities may not, initially, be identical in detail to Seller's Plans and Specifications, and (ii) because of the day-to-day nature of the changes described in this paragraph 14, the plans and specifications on file with applicable governmental authorities may not include some or any of these changes (there being no legal requirement to file all changes with such authorities). As a result of the foregoing, Buyer and Seller both acknowledge and agree: The Unit and the Condominium may not be constructed in accordance with the plans and specifications on file with applicable governmental authorities. Without limiting the generality of paragraph 31, Seller disclaims and Buyer waives any and all express or implied warranties that construction will be accomplished in compliance with such plans and specifications. Seller has not given and Buyer has not relied on or bargained for any such warranties. In furtherance of the foregoing, in the event of any conflict between the actual construction of the Unit and/or the Building, and that which is set forth on the plans, Buyer agrees that the actual construction shall prevail and to accept the Unit and Building as actually constructed (in lieu of what is set forth on the plans).

Without limiting the generality of the foregoing, because of Seller's need to coordinate the appearance and design of the overall development of the Condominium, both in connection with the nature and layout of the land on which construction is to take place and of the street, common elements and other features of the development, Buyer understands and agrees: The Unit may be constructed as a reverse ("mirror image") of that illustrated in the floor and building plan of the applicable model and building (as shown in the Condominium Documents or in any illustrations of the model and building); and may be "sited" in a position different from that of the applicable model and floor and building plan (or any such illustrations). Buyer agrees to accept the Unit and the said building as "sited" by Seller and as constructed according to a reverse floor and/or building plan. This paragraph does not limit the generality of Seller's rights, set out elsewhere in this Agreement, to make other changes in the Unit, the Condominium and the Condominium Documents.

Buyer understands and agrees that in designing the Condominium, the stairwells within the Condominium Property were intended primarily for ingress and egress in the event of emergency and, as such may be constructed and left unfinished solely as to be functional for said purpose, without regard to the aesthetic appearance of said stairwells. Similarly, the garage and utility pipes serving the Condominium are intended primarily for functional purposes, and as such may be left unfinished without regard to the aesthetic appearance of same. Further, Buyer

Buyer's Initials:

Purchase Agreement

- 8 -

Seller's Initials

hereby acknowledges and agrees that sound and/or odor transmission in a multi-story building such as the Condominium is very difficult to control, and that noises from adjoining or nearby Units and/or mechanical equipment, and/or elevators, plumbing and/or piping installations can often be heard in other Units. Without limiting the generality of paragraph 31, Seller does not make any representation or warranty as to the level of sound and/or odor transmission between and among Units and the other portions of the Condominium Property, and Buyer hereby waives and expressly releases any such warranty and claim for loss or damages resulting from sound and/or odor transmission. Lastly, Buyer understands and agrees that there are various methods for calculating the square footage of a Unit, and that depending on the method of calculation, the quoted square footage of the Unit may vary by more than a nominal amount. Additionally, as a result of in the field construction and other permitted changes to the Unit, as more fully described in this paragraph, actual square footage of the Unit may also be affected. Accordingly, during the pre-closing inspection, Buyer should, among other things, review the size and dimensions of the Unit. By closing, Buyer shall be deemed to have conclusively agreed to accept the size and dimensions of the Unit, regardless of any variances in the square footage. Without limiting the generality of any other provision of this Agreement, Seller does not make any representation or warranty as to the actual size, dimensions (including ceiling heights) or square footage of the Unit. Nothing herein shall be deemed to deny or abridge the rights granted under Section 718.506, Florida Statutes.

The agreements and waivers of Buyer contained in this paragraph will survive (continue to be effective after) closing.

15. Certain Items and Materials. Buyer understands and agrees that certain items, which may be seen in models (if any) or in illustrations, are not necessarily included with the sale of the Unit, but rather are displayed to provide Buyer with ideas for furnishing and decorating the Unit. Buyer understands and agrees that only those items of personal property which are specifically provided for in a Rider or Schedule to this Agreement signed by both Buyer and Seller are to be included with the Unit.

Buyer further understands and agrees that certain items, if included with the Unit, such as tile, cabinets, wood, stain, grout, wall and ceiling textures, cultured marble, granite, stone, mica and carpeting, are subject to size and color variations, grain and quality variations, and may vary in accordance with price, availability and changes by manufacturer from those shown in the models or in illustrations or included in Seller's Plans and Specifications or in the published list of standard items (if any). If circumstances arise which, in Seller's opinion, warrant changes of suppliers, manufacturers, brand names or items, or if Seller elects to omit certain items, Seller may modify the list of standard features or make substitutions for equipment, material, appliances, etc., with items which in Seller's opinion are of equal or better quality (regardless of cost). Buyer also understands and acknowledges that Seller has the right to substitute or change materials and/or stain colors utilized in wood decor (if any). Buyer recognizes that certain colors as shown in displays or in the models, including, but not limited to, carpeting and wood stain, will weather and fade and may not be duplicated precisely.

If Seller allows Buyer to select certain colors and/or materials in the Unit (which Seller is not obligated to do), Buyer understands and agrees that Buyer must submit Buyer's selections to Seller in writing within fourteen (14) days after the date the list of selections (if any) is made available to Buyer. If these selections (if any) are not delivered to Seller in writing within the time period stated above, then it is agreed and understood that the choices will be made by Seller in Seller's sole discretion.

The agreements and waivers of Buyer contained in this paragraph will survive (continue to be effective after) closing.

16. Litigation. In the event of any litigation between the parties under this Agreement, the prevailing party shall be entitled to reasonable attorney's, paralegals and para-professionals fees and court costs at all trial and appellate levels. This paragraph will survive (continue to be effective after) any termination of this Agreement, but shall otherwise be deemed merged into the deed at closing.

17. Maintenance Fee. Buyer understands and agrees that the Estimated Operating Budget for the Condominium Association Common Expenses and the costs associated with the operation and maintenance of the Shared Components (the "Budgets") contained in the Condominium Documents provide only an estimate of what it will cost to run the Association and operate and maintain the respective facilities during the period of time stated in the Budgets. The monthly assessments shown in the Condominium Association Budget for the Unit are guaranteed, if at all, in the manner stated in the Condominium Documents. Please note, however, that in addition to the amounts payable to the Condominium Association, each Owner shall be obligated to pay assessments in connection with the operation and maintenance of the Shared Components. These assessments and costs are not guaranteed in any manner. The Budgets, themselves however, as opposed to the levels of assessments payable to the Condominium Association, are not guaranteed, and there may be changes in the applicable Budgets at any time to cover increases or decreases in actual expenses or in estimates. Changes in the applicable Budgets may be made at any time to cover increases or decreases in actual expenses or in estimates. It is intended that the Seller, as the sole Unit Owner upon the formation of the Condominium, will vote not to provide any reserves for the initial year of the Condominium. Thereafter, on an annual basis, a majority of the Condominium Association's members may vote to continue not to provide any reserves for the Condominium. Reserves are expected to be collected annually with respect to the Shared Components.

Buyer's Initials:

Purchase Agreement

Seller's Initials

18. Condominium Association. This Agreement is also Buyer's application for membership in the Condominium Association, which membership shall automatically take effect at closing. At that time, Buyer agrees to accept the liabilities and obligations of membership.

19. Seller's Use of the Condominium Property. As long as Seller (or any of its affiliates) owns a Unit or Units or any other portion of Condominium Property and is offering same in the ordinary course of business, it and its agents are hereby given full right and authority to place and maintain on, in and about the Condominium Property and/or the Association Property (excluding the Unit after closing) model units, sales and leasing offices, administrative offices, signs and lighting related to construction and sales promotion purposes, for such period of time, at such locations and in such forms as shall be determined by Seller in its sole and absolute discretion. Seller, its employees, agents contractors and prospective buyers are also hereby given, for construction and sales promotion purposes, the right of entry upon, ingress to, egress from and other use of the Condominium Property and/or Association Property (excluding the Unit after closing), and the right to restrict and regulate access to the Common Elements and/or Association Property, subject to Buyer's reasonable access to and from the Unit after closing, for the purposes of completing construction of the Common Elements, Association Property and/or other Units within the Condominium Property. Seller's salespeople can show units, the Association Property and/or the Common Elements, erect advertising signs and do whatever else is necessary in Seller's opinion to help sell, resell or lease Units or other portions of any improvements to be constructed upon the Condominium Property or develop and manage the Condominium Property and/or Association Property, or to provide management and administration and/or financial services, but Seller's use of the Condominium Property and/or Association Property must be reasonable, in Seller's opinion, and cannot unreasonably interfere, in Seller's opinion, with Buyer's use and enjoyment of the Unit. This paragraph will survive (continue to be effective after) closing.

20. Sales Commissions. Seller will pay all sales commissions due its in-house sales personnel and/or exclusive listing agent and the co-broker, if any, identified on the last page of this Purchase Agreement (if such space is left blank, it shall mean that Seller has not agreed to pay any co-broker and that Buyer represents that there is no co-broker who can claim by, through or under Buyer), provided that such co-broker has properly registered with Seller as a participating co-broker. By signing this Agreement, Buyer is representing and warranting to Seller that Buyer has not consulted or dealt with any broker, salesperson, agent or finder other than Seller's sales personnel (and the co-broker, if any, named on the last page of this Agreement), nor has the sale been procured by any real estate broker, salesperson, agent or finder other than Seller's sales personnel (and the co-broker, if any, named on the last page of this Agreement). Buyer will indemnify and hold Seller harmless for and from any such person or company claiming otherwise. Buyer's indemnity and agreement to hold Seller harmless includes, without limitation, Buyer's obligation to pay or reimburse Seller for all commissions, damages and other sums for which Seller may be held liable and all attorneys' fees and court costs actually incurred by Seller (including those for appeals), regardless of whether a lawsuit(s) is actually brought or whether Seller ultimately wins or loses.

This paragraph will survive (continue to be effective after) closing.

21. Notices. Whenever Buyer is required or desires to give notice to Seller, the notice must be in writing and it must be sent certified mail, postage prepaid, with a return receipt requested to Seller at 19501 Biscayne Boulevard, Suite 400, Aventura, FL 33180; Attn: Legal Department, or such other addresses as Seller may otherwise direct. Notwithstanding the foregoing, Buyer's notice to cancel pursuant to Paragraph 28 below, may be made in any manner permitted under the Interstate Land Sales Full Disclosure Act and the regulations promulgated thereunder.

Unless this Agreement states other methods of giving notices, whenever Seller is required or desires to give notice to Buyer, the notice must be given either in person, by telephone or in writing and, if in writing, it must be sent either by: (i) certified mail, postage prepaid, with a return receipt requested (unless sent outside of the United States, in which event written notices to Buyer may be sent by regular air mail); (ii) facsimile transmission if Buyer has indicated a telecopy number on Page 1 of this Agreement; or (iii) a recognized overnight courier service (i.e., FedEx, Express Mail, United Parcel Service, etc.), to the address for Buyer set forth on Page 1 of this Agreement.

A change of address notice is effective when it is received. All other written notices are effective on the day they are properly given or mailed, whether or not received (and all permitted non-written notices to Buyer are effective on the date given by Seller) unless receipt is required specifically in portions of this Agreement.

22. Transfer or Assignment. Buyer shall not be entitled to assign this Agreement or its rights hereunder without the prior written consent of Seller, which may be withheld by Seller with or without cause (and even if Seller's refusal to grant consent is unreasonable). To the extent that Seller consents to any such assignment, said consent may be conditioned in any manner whatsoever, including, without limitation, charging an assignment or transfer fee. Any such assignee must fully assume all of the obligations of Buyer hereunder by written agreement for Seller's benefit, a counterpart original executed copy of which shall be delivered to Seller. If Buyer is a corporation, partnership, other business entity, trustee or nominee, a transfer of any direct or indirect stock, voting interest, partnership interest, equity, beneficial or principal interest in Buyer will constitute an assignment of this Agreement requiring consent. Without limiting the generality of the foregoing, Buyer shall not, prior to closing on title to the Unit, unless first obtaining the prior written consent of Seller (which may be granted or withheld in Seller's sole and absolute discretion) advertise, market and/or list the Unit for sale or resale, whether by placing an advertisement, listing the Unit with a broker, posting signs at the Unit or at the Condominium, allowing the Unit to be listed for sale on the internet or the Multiple Listing Service or otherwise. Any violation of any of the foregoing provisions of this

Buyer's Initials:

Purchase Agreement

Seller's Initials

paragraph 22 shall be deemed an immediate default by Buyer under this Agreement (which is not capable of cure and for which no notice must be given).

23. Others Bound by this Agreement. If Buyer dies or in any way loses legal control of Buyer's affairs, this Agreement will bind Buyer's heirs and personal representatives. If Buyer has received permission to assign or transfer Buyer's interest in this Agreement, this Agreement will bind anyone receiving such interest. If Buyer is a corporation or other business entity, this Agreement will bind any successor corporation or entity. If more than one person signs this Agreement as buyer, each will be equally liable, on a joint and several basis, for full performance of all Buyer's duties and obligations under it and Seller can enforce it against either as individuals or together.

24. Public Records. Buyer authorizes Seller to record the documents needed to establish and operate the Condominium, as well as all other documents which Seller deems necessary or appropriate, in the Public Records of Miami-Dade County, Florida. Neither this Agreement, nor any notice or memorandum hereof (nor any Lis Pendens), may be recorded.

25. Buyer's Right to Cancel. THIS AGREEMENT IS VOIDABLE BY BUYER BY DELIVERING WRITTEN NOTICE OF THE BUYER'S INTENTION TO CANCEL WITHIN 15 DAYS AFTER THE DATE OF EXECUTION OF THIS AGREEMENT BY THE BUYER, AND RECEIPT BY BUYER OF ALL OF THE ITEMS REQUIRED TO BE DELIVERED TO HIM OR HER BY THE DEVELOPER UNDER SECTION 718.503, FLORIDA STATUTES. THIS AGREEMENT IS ALSO VOIDABLE BY BUYER BY DELIVERING WRITTEN NOTICE OF THE BUYER'S INTENTION TO CANCEL WITHIN 15 DAYS AFTER THE DATE OF RECEIPT FROM THE DEVELOPER OF ANY AMENDMENT WHICH MATERIALLY ALTERS OR MODIFIES THE OFFERING IN A MANNER THAT IS ADVERSE TO THE BUYER. ANY PURPORTED WAIVER OF THESE VOIDABILITY RIGHTS SHALL BE OF NO EFFECT. BUYER MAY EXTEND THE TIME FOR CLOSING FOR A PERIOD OF NOT MORE THAN 15 DAYS AFTER THE BUYER HAS RECEIVED ALL OF THE ITEMS REQUIRED. BUYER'S RIGHT TO VOID THIS AGREEMENT SHALL TERMINATE AT CLOSING.

If Buyer does not cancel this Agreement during this fifteen (15) day period, it means that Buyer ratifies this Agreement and the Condominium Documents and Buyer agrees that their provisions are fair and reasonable in Buyer's opinion.

26. Coastal Construction Control Line. Buyer is aware that the Unit and/or portions of the Condominium may be located in coastal areas partially or totally seaward of the coastal construction control line as defined in Section 161.053, F.S. Buyer is fully apprised of the character of the regulation of property in such coastal areas and Buyer hereby waives and releases any right to receive at closing a survey delineating the location of the coastal construction control line with respect to the Unit and the Condominium in accordance with Section 161.57, F.S.

27. Florida Law; Severability. Any disputes that develop under this Agreement will be settled according to Florida law. If any part of this Agreement violates a provision of applicable law, the applicable law will control. In such case, however, the rest of the Agreement (not in violation) will remain in force.

Without limiting the generality of the foregoing, it is Buyer's and Seller's mutual desire and intention that all provisions of this Agreement be given full effect and be enforceable strictly in accordance with their terms. If, however, any part of this Agreement is not enforceable in accordance with its terms or would render other parts of this Agreement or this Agreement, in its entirety, unenforceable, the unenforceable part or parts are to be judicially modified, if at all possible, to come as close as possible to the expressed intent of such part or parts (and still be enforceable without jeopardy to other parts of this Agreement, or this Agreement in its entirety), and then are to be enforced as so modified. If the unenforceable part or parts cannot be so modified, such part or parts will be unenforceable and considered null and void in order that the mutual paramount goal (that this Agreement is to be enforced to the maximum extent possible strictly in accordance with its terms) can be achieved.

28. Changes. Seller may make changes in the Condominium Documents in its sole discretion by providing Buyer with all such amendments that are made, provided that, as to these changes, Buyer will have fifteen (15) days from the date of receipt of such changes from Seller which materially alter or modify the offering of the Condominium in a manner adverse to Buyer in which to cancel this Agreement (by delivering written notice to Seller of such cancellation) and receive a refund of any deposits with applicable interest earned, if any. Seller will be relieved of all obligations under this Agreement when Seller refunds the deposits and interest, if any. Buyer will not be permitted to prevent Seller from making any change it wishes in its sole discretion, nor to pursue any remedy other than the fifteen (15) day cancellation remedy described above (and then only for the kind of changes that materially alter or modify the offering in a manner that is adverse to Buyer).

If Buyer has the right to cancel this Agreement by reason of a change which materially alters or modifies the offering of the Condominium in a manner adverse to Buyer, Buyer's failure to request cancellation in writing within the fifteen (15) day period will mean that Buyer accepts the change and waives irrevocably Buyer's right so to cancel. All rights of cancellation will terminate, if not sooner, then absolutely at closing. After closing, Buyer will have no remedy for any changes Seller may make or have made.

Buyer's Initials:

Purchase Agreement

Seller's Initials

Without limiting the generality of the foregoing and other provisions of this Agreement, Seller is specifically authorized to: (i) substitute the final legal descriptions and as-built surveys for the proposed legal descriptions and plot plans contained in the Condominium Documents even though changes occur in the permitting stage and during construction, and/or (ii) combine and/or subdivide units prior to the recordation of the Declaration (and incorporate divider wall Common Elements in any such combination units or add Common Element divider walls in any such subdivision), provided that the percentage share of ownership of Common Elements of any Unit not affected in the combination or subdivision is not affected.

This paragraph will survive (continue to be effective after) closing.

29. Nearby Construction. Buyer understands and agrees that for some time in the future Buyer may be disturbed by the noise, commotion and other unpleasant effects of nearby construction activity and impeded in using portions of the Condominium Property by that activity. Because the Condominium is located in an urban area, demolition or construction of buildings and other structures within the immediate area or within the view lines of any particular Unit or of any part of the Condominium (the "Views") may block, obstruct, shadow or otherwise affect Views, which may currently be visible from the Unit or from the Condominium. Therefore, the Buyer hereby agrees to release Seller, its partners and its and their officers, members, Directors and employees and every affiliate and person related or affiliated in any way with any of them ("Seller's Affiliates") from and against any and all losses, claims, demands, damages, costs and expenses of whatever nature or kind, including attorney's fees and costs, including those incurred through all arbitration and appellate proceedings, related to or arising out of any claim against the Seller or Seller's Affiliates related to Views or the disruption, noise, commotion, and other unpleasant effects of nearby development or construction. As a result of the foregoing, there is no guarantee of view, security, privacy, location, design, density or any other matter, except as is set forth herein or in the Prospectus.

Additionally, inasmuch as the Hotel Unit may attract customers, patrons and/or guests who are not members of the Association, such additional traffic over and upon the Condominium Property shall not be deemed a nuisance hereunder.

30. Time of Essence. The performance by Buyer of all obligations on the precise times stated in this Agreement is of absolute importance and failure of Buyer to so perform on time is a default, time being of the essence.

31. Disclaimer of Implied Warranties. All manufacturers' warranties will be passed through to Buyer at closing. At closing, Buyer will receive the statutory warranties imposed by the Florida Condominium Act.

To the maximum extent lawful, all implied warranties of fitness for a particular purpose, merchantability and habitability, all warranties imposed by statute (except only those imposed by the Florida Condominium Act to the extent they cannot be disclaimed and to the extent they have not expired by their terms) and all other implied or express warranties of any kind or character are specifically disclaimed. Without limiting the generality of the foregoing, Seller hereby disclaims any and all express or implied warranties as to design, construction, view, sound and/or odor transmission, furnishing and equipping of the Condominium Property, the existence of molds, mildew, spores, fungi and/or other toxins within the Condominium Property, except only those set forth in Section 718.203 of the Act, to the extent applicable and to the extent that same have not expired by their terms. Seller has not given and Buyer has not relied on or bargained for any such warranties.

As to any implied warranty which cannot be disclaimed entirely, all secondary, incidental and consequential damages are specifically excluded and disclaimed (claims for such secondary, incidental and consequential damages being clearly unavailable in the case of implied warranties which are disclaimed entirely above).

Buyer acknowledges and agrees that Seller does not guarantee, warrant or otherwise assure, and expressly disclaims, any right to view and/or natural light.

Further, given the climate and humid conditions in South Florida, molds, mildew, spores, fungi and/or other toxins may exist and/or develop within the Unit and/or the Condominium Property. Buyer is hereby advised that certain molds, mildew, spores, fungi and/or other toxins may be, or if allowed to remain for a sufficient period may become, toxic and potentially pose a health risk. By executing and delivering this Agreement and closing, Buyer shall be deemed to have assumed the risks associated with molds, mildew, spores, fungi and/or other toxins and to have released and indemnified Seller and Seller's Affiliates from and against any and all liability or claims resulting from same, including, without limitation, any liability for incidental or consequential damages (which may result from, without limitation, the inability to possess the Unit, inconvenience, moving costs, hotel costs, storage costs, loss of time, lost wages, lost opportunities and/or personal injury and death to or suffered by any of Buyer's Guests as defined below and any other person or any pets). Without limiting the generality of the foregoing, leaks, leaving exterior doors or windows open, wet flooring and moisture will contribute to the growth of mold, mildew, fungus or spores. Buyer understands and agrees that Seller is not responsible for, and Seller hereby disclaims any responsibility for any illness or allergic reactions which may be experienced by Buyer, its pets, its family members and/or its or their guests, tenants and invitees (collectively "Buyer's Guests") as a result of mold,

Buyer's Initials:

Purchase Agreement

Seller's Initials

mildew, fungus or spores. It is solely the Buyer's responsibility to keep the Unit clean, dry, well-ventilated and free of contamination.

This paragraph will survive (continue to be effective after) closing.

32. Return of Condominium Documents. If this Agreement is canceled for any reason, Buyer will return to Seller all of the Condominium Documents delivered to him in the same condition received, reasonable wear and tear excepted. If Buyer fails to return the Condominium Documents, Buyer agrees to pay Seller \$50.00 to defray the costs of preparation, printing and delivery of same.

33. Roadways. Access to the Condominium is via State Road A-1-A, commonly known as Collins Avenue (State Road 140) which is a six (6) lane divided street. The width of Collins Avenue at that location is approximately one hundred (100) feet and is asphalt covered. Collins Avenue is a public road, primarily maintained by the applicable governmental authorities. Private access drives will be constructed by Seller. These private access drives will have at least one lane of traffic in each direction. The cost of road construction will be borne by Seller, however, there is no financial assurance of completion of the private access drives. See the Property Report delivered to you simultaneously herewith for details regarding the maintenance of the private access road.

34. Waiver. Seller's waiver of any of its rights or remedies (which can only occur if Seller waives any right or remedy in writing) will not waive any other of Seller's rights or remedies or prevent Seller from later enforcing all of Seller's rights and remedies under other circumstances.

35. Survival. Only those provisions and disclaimers in this Agreement which specifically state that they shall have effect after closing will survive (continue to be effective after) closing and delivery of the deed. All other provisions shall be deemed merged into the deed.

36. Substantial Completion. Whenever this Agreement requires Seller to complete or substantially complete an item of construction, that item will be understood to be complete or substantially complete when so complete or substantially complete in Seller's reasonable opinion. Notwithstanding the foregoing, however, neither the Unit nor the Building of which the Unit is a part will be considered complete or substantially complete for purposes of this Agreement unless the Unit (and such portion of the Building intended to be used exclusively by Buyer) is physically habitable and usable for the purpose for which the Unit was purchased and the certification of substantial completion described in Section 718.104(4)(e), Florida Statutes, is included as an exhibit to the Declaration, as recorded. The Unit (and such portion of the Building) will be considered so useable if the Unit is ready for occupancy and has all necessary and customary utilities extended to it. Other units (and other portions of the building) may not necessarily be so complete and useable.

37. Local Agent. Buyer agrees to deliver to Seller, within forty-five (45) days following the date of this Agreement, an executed designation of an individual qualified to accept service of process in the State of Florida, which such designation shall be irrevocable unless Buyer effectively appoints a substitute local agent and notifies Seller of such substituted designation. If Buyer fails to deliver such designation, Buyer shall be deemed to have appointed the Secretary of State, State of Florida, as its agent for such purposes.

38. Buyer's Certification. Buyer hereby certifies, under penalties of perjury, that the taxpayer's identification number for Buyer as set forth on page 1 hereof is correct, and understands that failure to provide the correct taxpayer's identification number, as required by law, may subject Buyer to civil or criminal penalties.

39. Inducement. Buyer acknowledges that the primary inducement for Buyer to purchase under this Agreement is the Unit, itself, and not the recreational amenities and other proposed improvements which may, or may not, be constructed within The Properties.

40. Disclosures. Under the laws of the State of Florida, Buyer is hereby advised as follows:

(a) **RADON GAS:** Radon is a naturally occurring radioactive gas that, when it has accumulated in a building in sufficient quantities, may present health risks to persons who are exposed to it over time. Levels of radon that exceed federal and state guidelines have been found in buildings in Florida. Additional information regarding radon and radon testing may be obtained from your county health department. The foregoing notice is provided in order to comply with state law and is for informational purposes only. Seller does not conduct radon testing with respect to the Units or the Condominium, and specifically disclaims any and all representations or warranties as to the absence of radon gas or radon producing conditions in connection with the Condominium.

(b) **CHAPTER 558, FLORIDA STATUTES CONTAINS IMPORTANT REQUIREMENTS YOU MUST FOLLOW BEFORE YOU MAY BRING ANY LEGAL ACTION FOR AN ALLEGED CONSTRUCTION DEFECT IN YOUR UNIT OR CONDOMINIUM. SIXTY DAYS BEFORE YOU BRING ANY LEGAL ACTION, YOU MUST DELIVER TO THE OTHER PARTY TO THIS AGREEMENT, A WRITTEN NOTICE REFERRING TO CHAPTER 558 OF ANY CONSTRUCTION CONDITIONS YOU ALLEGE ARE DEFECTIVE AND PROVIDE SUCH PERSON THE OPPORTUNITY TO INSPECT THE ALLEGED CONSTRUCTION DEFECTS AND TO CONSIDER**

Buyer's Initials:

Purchase Agreement

Seller's Initials

MAKING AN OFFER TO REPAIR OR PAY FOR THE ALLEGED CONSTRUCTION DEFECTS. YOU ARE NOT OBLIGATED TO ACCEPT ANY OFFER WHICH MAY BE MADE. THERE ARE STRICT DEADLINES AND PROCEDURES UNDER THIS FLORIDA LAW WHICH MUST BE MET AND FOLLOWED TO PROTECT YOUR INTERESTS.

- (c) BUYER SHOULD NOT RELY ON THE SELLER'S CURRENT PROPERTY TAXES AS THE AMOUNT OF PROPERTY TAXES THAT THE BUYER MAY BE OBLIGATED TO PAY IN THE YEAR SUBSEQUENT TO PURCHASE. A CHANGE OF OWNERSHIP OR PROPERTY IMPROVEMENTS TRIGGERS REASSESSMENTS OF THE PROPERTY THAT COULD RESULT IN HIGHER PROPERTY TAXES. IF YOU HAVE ANY QUESTIONS CONCERNING VALUATION, CONTACT THE COUNTY PROPERTY APPRAISER'S OFFICE FOR INFORMATION.
- (d) The Condominium is structured to operate as a hotel. Residential Unit Owners, through the Association, do not exercise the control over the operation of the Condominium normally found in residential condominiums.

41. Incorporation: Definitions. The explanations, definitions, disclaimers and other provisions set forth in the Condominium Documents are incorporated into this Agreement as if repeated at length here. When the words "this Agreement" are used, they shall include in their meaning all modifications, riders and addenda to it signed by Buyer and Seller.

42. Seller's Representations. Buyer acknowledges, warrants, represents and agrees that this Agreement is being entered into by Buyer without reliance upon any representations concerning any potential for future profit, any future appreciation in value, any rental income potential, tax advantages, depreciation or investment potential and without reliance upon any hotel affiliation or any monetary or financial advantage. Further, no statements or representations have been made by Seller, or any of its agents, employees or representatives with respect to (i) the ability or willingness of Seller or its affiliates to assist Buyer in renting or selling the Unit (except only in response to a direct inquiry from Buyer), (ii) the economic or tax benefits to be derived from the managerial efforts of a third party as a result of renting the Unit or other units, or (iii) the economic or tax benefits to be derived from ownership of the Unit. Buyer acknowledges and agrees that no such representations, including representations as to the ability or willingness of Seller or its affiliates to assist Buyer in renting or selling the Unit, have been made by Seller, or any of its agents, employees or representatives. Buyer further represents and warrants to Seller that Buyer is entering into this Agreement with the full intention of complying with each and every of the obligations hereunder, including, without limitation, the obligation to close on the purchase of the Unit. Neither Seller, nor anyone working by, through or under Seller, has made any statement or suggestion that Buyer would not be obligated to fully comply with the terms of this Agreement and to close on the purchase of the Unit. Further, Buyer understands and agrees that neither Seller, nor any brokerage company, in-house sales personnel and/or other persons working by, through or under Seller, are under any obligation whatsoever to assist Buyer with any resale of the Unit.

This Agreement contains the entire understanding between Buyer and Seller, and Buyer hereby acknowledges that the displays, architectural models, artist renderings and other promotional materials contained in the sales office and model suite are for promotional purposes only and may not be relied upon. Buyer warrants that Buyer has not relied upon any verbal representations, advertising, portrayals or promises other than as expressly contained herein and in the Condominium Documents, including, specifically, but without limitation, any representations as to: (a) potential appreciation in or resale value of the Unit, (b) the existence of any "view" from the Unit or that any existing "view" will not be obstructed in the future, (c) traffic conditions in, near or around the Condominium, (d) disturbance from nearby properties, (e) disturbance from air or vehicular traffic, or (f) any particular hotel affiliation or maintaining any existing hotel affiliation. The provisions of this paragraph shall survive the closing.

43. Offer. The submission by Seller of this Agreement to Buyer for examination does not constitute an offer by Seller to Buyer, or a reservation of or option for any Unit in the Condominium. This Agreement shall not become binding until executed and delivered by both Buyer and Seller. Upon execution by Seller, an executed copy of this Agreement shall be sent to Buyer, otherwise the firm offer shall be considered rejected and all funds deposited by Buyer shall be promptly returned to Buyer.

44. Liability. The liability of Seller under this Agreement or any amendment or any instrument or document executed in connection with this Agreement shall be limited to and enforceable solely against the interest of Seller in the Condominium, and not against any other assets of Seller or any partner of Seller (or its or their officers, principals, Directors, employees, managers, members or agents).

45. Interpretation. Notwithstanding that this Agreement was prepared by one (1) party hereto, it shall not be construed more strongly against or more favorably for either party; it being known that both parties have had equal bargaining power, have been represented (or have had the opportunity to be represented) by their own independent counsel and have equal business acumen such that any rule of construction that a document is to be construed against the drafting party shall not be applicable. Buyer acknowledges and agrees that Buyer has had ample opportunity to inspect other similar condominiums and condominium documents, that Seller has clearly disclosed to Buyer the right to cancel this Agreement for any reason whatsoever, including any dissatisfaction Buyer may have with this Agreement or the Condominium Documents, within fifteen (15) days of the date Buyer executes

Buyer's Initials:

Seller's Initials

this Agreement or has received the Condominium Documents, whichever is later, and that although Seller's sales agents are not authorized to change the form of this Agreement, they have strict instructions from Seller to communicate any of Buyer's requests for such changes to Seller's management, which has given Buyer the opportunity to discuss and negotiate such changes.

46. Move-In Date. Buyer shall be entitled to possession of the Unit as of the Closing Date; however, Buyer's right to move into the Unit shall be subject to a "move-in" schedule for all buyers and the move must be scheduled with the Association, or its manager. Moving shall only be permitted in accordance with the Rules and Regulations of the Association.

47. Entire Agreement. This Agreement is the entire contract for sale and purchase of the Unit and once it is signed, it can only be amended by a written instrument signed by the party against whom enforcement is sought which specifically states that it is amending this Agreement. Any current or prior agreements, representations, understandings or oral statements of sales representatives or others, if not expressed in this Agreement, the Condominium Documents or in brochures for the Condominium, are void and have no effect. Buyer has not relied on them.

*** SIGNATURES ARE CONTAINED ON THE FOLLOWING PAGE ***

Buyer's Initials:

Purchase Agreement

- 15 -

Seller's Initials

GENERAL INFORMATION:

Co-Broker Information: (See paragraph 20 above; if the space for Co-Broker's name is left blank, it shall mean that Seller has not agreed to pay any co-broker)

Co-Broker's Name: _____

Co-Broker's Sales Agent: _____

Co-Broker's Address: _____

Phone No. _____

Fax No. _____

E-Mail _____

License No. _____

ANY PAYMENT IN EXCESS OF 10 PERCENT OF THE PURCHASE PRICE MADE TO DEVELOPER PRIOR TO CLOSING PURSUANT TO THIS CONTRACT MAY BE USED FOR CONSTRUCTION PURPOSES BY THE DEVELOPER.

YOU HAVE THE OPTION TO CANCEL YOUR CONTRACT OR AGREEMENT OF SALE BY NOTICE TO THE SELLER UNTIL MIDNIGHT OF THE FIFTEENTH DAY FOLLOWING THE SIGNING OF THE CONTRACT OR AGREEMENT.

IF YOU DID NOT RECEIVE A PROPERTY REPORT PREPARED PURSUANT TO THE RULES AND REGULATIONS OF THE OFFICE OF INTERSTATE LAND SALES REGULATION, U.S. DEPARTMENT OF HOUSING AND URBAN DEVELOPMENT, IN ADVANCE OF YOUR SIGNING THE CONTRACT OR AGREEMENT, THE CONTRACT OR AGREEMENT MAY BE CANCELED AT YOUR OPTION, FOR TWO YEARS FROM THE DATE OF SIGNING.

Witnesses:

BUYER(S)

Date: _____
SELLER:

FONTAINEBLEAU FLORIDA TOWER 3, LLC, a Florida limited liability company

By: _____
Authorized Representative

Date: _____

Exhibit "A"

ESCROW AGREEMENT

THIS AGREEMENT is made as of the 27th day of March, 2005, by and between CHICAGO TITLE INSURANCE COMPANY ("Escrow Agent"), having an office at 2701 Gateway Drive, Pompano Beach, Florida 33069, and FONTAINEBLEAU FLORIDA TOWER 3, LLC, a Florida limited liability company ("Developer"), having an office at 19501 Biscayne Boulevard, Suite 400, Aventura Florida 33180.

WITNESSETH

A. Developer proposes to construct and develop a condominium in Miami-Dade County, Florida, to be located at approximately the 45th block of Collins Avenue, Miami Beach, Florida, named FONTAINEBLEAU III OCEAN CLUB CONDOMINIUM (as may hereinafter be renamed, the "Condominium").

B. Developer has or intends to enter into contracts for the sale and purchase of units in the Condominium (each of which is hereinafter called a "Contract").

C. Developer desires to make arrangements to escrow deposits on each Contract in accordance herewith and with the provisions of Section 718.202, Florida Statutes. Deposits under each Contract up to ten percent (10%) of the sales price of the applicable Contract shall be held, subject to clearance, in a separate escrow account hereinafter referred to as the "Ten Percent Escrow Account" and deposits in excess of ten percent (10%) of the sales price of the applicable Contract shall be held, subject to clearance, in a separate escrow account hereinafter referred to as the "Special Escrow Account". Developer intends to post other assurances with the Division of Florida Land Sales, Condominiums, and Mobile Homes of the Department of Business and Professional Regulation of the State of Florida (the "Division"), having its office at Northwood Centre, 1940 North Monroe Street, Tallahassee, Florida 32399-1033, as allowed by Florida Statutes, so as to authorize release of funds to Developer from the Ten Percent Escrow Account in accordance herewith.

D. Escrow Agent has consented to hold all deposits it receives pursuant to the terms and provisions hereof.

NOW, THEREFORE, Escrow Agent and Developer hereby agree as follows:

1. From time to time, Developer will deliver checks payable to or endorsed to Escrow Agent which will represent deposits on Contracts, together with a copy of each executed Contract and all exhibits, attachments and modifications thereto (if not previously delivered with prior deposits) and a "Notice of Escrow Deposit" in the form attached hereto. Escrow Agent shall acknowledge receipt of the deposit and deliver an executed copy of same to Developer, and to the individual Condominium unit purchaser upon request. Developer shall also inform Escrow Agent as to whether Developer intends to post alternative assurances, and if so, the estimated amount of such assurance and when it will be provided. In accordance with Paragraph 2 of this Escrow Agreement, in the event the Division accepts the assurance as being sufficient and Developer furnishes Escrow Agent with a copy of the Division's approval along with the Withdrawal Certificate as hereinafter defined, Developer shall be entitled to receive a release of the escrow funds from the "Ten Percent Escrow Account."

2. Developer reserves the option to submit an assurance in accordance with Section 718.202(1), Florida Statutes. Upon such application for an assurance, Developer shall submit a quarterly report pursuant to Rule 61B-17.009 F.A.C. The Division has the discretion to accept alternative assurances from Developer in lieu of the escrow of all or any portion of the funds required to be escrowed hereunder. Developer may, but is not obligated to, submit to the Division for approval a letter of credit or other assurance, such as surety bonds or cash, as may be approved by the Division from time to time. If the Division accepts the assurance as being sufficient, such assurance shall serve as security for all or a portion of the deposits otherwise required to be escrowed hereunder in accordance with the terms and conditions of this Escrow Agreement. Developer shall be obligated to furnish Escrow Agent with a copy of the Division's approval of any assurance along with a certificate of Developer (the "Withdrawal Certificate") that such assurance is adequate in amount to cover deposits up to ten percent (10%) of the sales price for all sales of condominium units in the Condominium. Notwithstanding anything contained herein to the contrary, no substitute assurance arrangements shall be instituted, and Escrow Agent may not rely on any such substitute assurance, without the prior written approval of the Division.

3. Escrow Agent shall establish, in accordance with the requirements of Section 718.202, Florida Statutes separate accounts which shall be identified as the Ten Percent Escrow Account and the Special Escrow Account (collectively referred to herein as the "Escrow Account" or "Escrow Accounts"). Escrow Agent shall, at Developer's discretion, invest the deposits received hereunder in savings or time deposits in institutions insured by an agency of the United States or in securities of the United States or any agency thereof, provided title thereto shall always evidence the escrow relationship. Escrow Agent shall at all times retain a part of the Escrow Accounts in immediately available forms of investment as a reserve for: (a) any Contract subject to the statutory fifteen (15) day voidability period; (b) anticipated closings; (c) disbursement to Developer from the Special Escrow Account for construction purposes; and (d) disbursement to Developer from the Ten Percent Escrow Account to the extent authorized under any irrevocable letter of credit or surety bond furnished Escrow Agent and the Division in accordance with Section 718.202, Florida Statutes, and this Agreement. Notwithstanding the pooling of deposits in the Ten Percent Escrow Account and the Special Escrow Account, deposits received under the Agreement by the Escrow Agent shall be deemed to be separate deposits under each respective contract for purchase of units in the Condominium. Escrow Agent assumes no liability or responsibility for any loss of funds which may result from the failure of any institution in which Developer directs that such savings, time deposits or money market accounts be invested nor any loss or impairment of funds deposited in escrow in the course of collection or while on deposit with a trust company, bank, or savings association resulting from failure, insolvency or suspension of such institution.

4. For so long as Developer maintains an acceptable assurance as contemplated herein, Developer will not be obligated to escrow the deposits under each Contract up to ten percent (10%) of the sales price of the applicable Contract

("Initial 10% Deposits") which are otherwise required to be escrowed hereunder with Escrow Agent; provided, however, that (i) the total amount of Initial 10% Deposits retained by Developer is less than or equal to the amount of the assurance, including all increases thereof, and (ii) in the event that Developer receives Initial 10% Deposits which, in the aggregate, exceed the amount of the assurance, any such excess Initial 10% Deposits shall be delivered to Escrow Agent immediately in accordance with the procedures set forth herein. Such excess Initial 10% Deposits may be redelivered to Developer upon the receipt by Escrow Agent of acknowledgement by the Division that the Division has received an increase in the amount of the assurance to cover the excess of the initial 10% Deposits. Escrow Agent shall disburse the funds deposited in the Ten Percent Escrow Account in accordance with the following:

- (a) To the purchaser within three (3) business days after receipt of Developer's written certification that the purchaser has properly terminated his Contract;
- (b) To Developer, with any interest earned thereon, within five (5) business days after receipt of Developer's written certification that the purchaser's Contract has been terminated by reason of said purchaser's failure to cure a default in the performance of purchaser's obligations thereunder, together with evidence of the delivery or communication of notice of default from Developer to the purchaser;
- (c) If the deposit of a purchaser held in the Ten Percent Escrow Account, together with any interest earned thereon, has not been previously disbursed in accordance with the provisions of paragraphs 4(a) or 4(b) above, the same shall be disbursed promptly to Developer or its designees upon receipt from Developer of a closing statement or other verification signed by the purchaser, or his attorney or authorized agent, reflecting that the transaction for the sale and purchase of a unit in the Condominium has been closed and consummated; provided, however, that no disbursement shall be made if prior to the disbursement Escrow Agent receives from purchaser written notice of a dispute between the purchaser and Developer until such dispute is settled and joint direction is forwarded to Escrow Agent;
- (d) If the construction, furnishing, and landscaping of the property to be submitted to condominium ownership has been substantially completed in accordance with the plans and specifications and representations made by Developer in the disclosures required by the Florida Condominium Act, Escrow Agent shall pay the escrow funds for the particular unit in the Condominium to Developer upon the written consent of the purchaser of the said unit or upon Escrow Agent receipt of a copy of a certificate of occupancy or an appropriate certificate of substantial completion of a surveyor, engineer or architect in accordance with Section 718.104(4)(e), Florida Statutes;
- (e) In the event Developer delivers one (1) or more irrevocable letters of credit or bonds to the Escrow Agent in accordance with Section 718.202, Florida Statutes, and this Agreement, then, upon receipt of a letter from the Division approving same (or any increase or extension of same) and the Developer's Withdrawal Certificate, Escrow Agent shall disburse to Developer the amount of the deposits now or thereafter held in the Ten Percent Escrow Account equal to, but not in excess of, the aggregate amount evidenced by the letter(s) of credit or bond(s) delivered to the Division and so approved; or
- (f) Escrow Agent shall at any time make distribution of the purchaser's deposit and interest earned thereon upon written direction executed by Developer and purchaser.

No disbursement need be made by Escrow Agent until sums necessary to make such disbursement have actually and finally cleared Escrow Agent's account.

5. Escrow Agent shall disburse the funds deposited in the Special Escrow Account in accordance with the following:

- (a) To the purchaser, within thirty (30) days after receipt of Developer's written certification that the purchaser has properly terminated his contract.
- (b) To Developer, within five (5) days after the receipt of Developer's written certification that the purchaser's contract has been terminated by reason of said purchaser's failure to cure a default in performance of purchaser's obligations thereunder.
- (c) To Developer (as to that portion of the deposits in the Special Escrow Account within five (5) days after receipt of the Developer's written certification that construction of the improvements of the Condominium has begun, that the Developer will use such funds in the actual construction and development of the Condominium property and that no part of these funds will be used for salaries or commissions, or for expenses of salesmen or for advertising purposes. Escrow Agent shall not, however, be responsible to assure that such funds are so employed and shall be entitled to rely solely on such certification.
- (d) If the deposit of a purchaser held in the Special Escrow Account has not been previously disbursed in accordance with the provisions of subparagraphs 5(a), 5(b) or 5(c) above, the same shall be disbursed immediately to Developer or its designees upon receipt from Developer of a closing statement or other verification signed by the purchaser, or his attorney or authorized agent, reflecting that the transaction for sale and purchase of the subject condominium unit has been closed and consummated; provided, however, that no disbursement shall be made if prior to the disbursement Escrow Agent receives from purchaser written notice of a dispute between the purchaser and Developer until such dispute is settled and joint direction is forwarded to Escrow Agent.

- (e) Escrow Agent shall at any time make distribution of the purchaser's deposit and interest earned thereon upon written direction duly executed by Developer and purchaser.

No disbursement need be made by Escrow Agent until sums necessary to make such disbursement have actually and finally cleared Escrow Agent's account.

6. From time to time Developer may deliver to the Escrow Agent, one or more irrevocable and unconditional letters of credit or a surety bond in favor of the Director of the Division and/or the Division. A copy of any letter of credit or surety bond shall be delivered to the Division, which copy shall be certified by the issuer as a true copy of the original. Upon the issuance of any such letter of credit or surety bond, and upon receipt of a letter from the Division approving same, Escrow Agent shall, within three (3) business days thereafter, disburse to Developer deposits held in the Ten Percent Escrow Account, or thereafter paid to Escrow Agent for deposit to the Ten Percent Escrow Account, up to but not exceeding the aggregate amount evidenced by the letter(s) of credit and/or surety bond delivered to the Division and approved in writing by it, subject to the terms, conditions and limitations hereinafter provided:

- (a) The letter(s) of credit and/or surety bond shall be in an amount which, when combined with the amount of any prior outstanding letter(s) of credit or surety bond presented to Escrow Agent, equals or exceeds the total of funds requested to be withdrawn plus the "Withdrawn Funds", as such term is defined below. The term "Withdrawn Funds" shall mean those funds previously withdrawn by Developer from the Ten Percent Escrow Account reduced by: (i) any sums paid to a purchaser as a result of the purchaser's termination of his Contract or as a result of a default by Developer under the Contract; and (ii) any sums paid to Developer as a result of a default by a purchaser under his Contract or as a result of the closing of a Contract. Any letter of credit or surety bond presented to Escrow Agent and the Division as a condition to a request for and disbursement of funds from the Ten Percent Escrow Account shall be in such form as may be approved by the Division.
- (b) Developer shall provide Escrow Agent with a monthly accounting of all funds or other property received from purchasers which are not escrowed because of the existence of an assurance, which monthly accounting shall be used by Escrow Agent as a means of compiling the status report required hereinafter. Escrow Agent shall be entitled to fully and completely rely upon the accuracy of said monthly accountings. Such monthly reports shall indicate the amount of monies for each purchaser then held by Developer and a list of purchasers whose Initial 10% Deposits have been retained. Additionally, pursuant to 61B-17.009, F.A.C., Developer shall provide the Division with quarterly reports relating to the escrow funds. A "Summary of Escrow Funds" statement shall be included with all requests for both initial approval as well as requests for changes to previously approved assurances. This summary shall include all projects; the amounts, which would be required to be deposited if no alternative assurance existed; the amount of the assurance; the amount available for withdrawal; and the balance in the escrow agreement.
- (c) Subject to furnishing the letters of credit and/or surety bond and approval thereof in accordance herewith, when Developer desires that funds be disbursed to it from the Ten Percent Escrow Account, it shall provide Escrow Agent with a written request therefor which shall certify to Escrow Agent that such funds will be used solely in compliance with the Condominium Act. Escrow Agent shall be entitled to rely upon Developer's representations in this regard and shall not be liable for any misuse by Developer of funds disbursed from the Ten Percent Escrow Account pursuant hereto.
- (d) Notwithstanding anything herein contained to the contrary (i) Developer shall supply the Division with a replacement of the assurance which is acceptable to the Division, not less than forty five (45) days prior to the expiration date of the existing assurance, and (ii) if Escrow Agent has not received notification from the Division that Developer has complied with this obligation, then thirty (30) days prior to the expiration of the assurance, Escrow Agent shall provide to the Division a statement showing the status of the total funds secured by the assurance as of the thirtieth (30th) day prior to the expiration of the assurance based on the monthly reports furnished by the Developer. Escrow Agent shall concurrently make demand for replacement of the alternative assurance pursuant to subparagraph (iii) above, or payment from the Developer to Escrow Agent of that amount of total funds secured by the assurance. In the event that such payment is not received by Escrow Agent within five (5) days following the mailing of the demand by Escrow Agent, then Escrow Agent shall make demand upon the assurance to the extent of the amount of funds and place such funds with Escrow Agent in the Ten Percent Escrow Account, to be held and maintained by Escrow Agent in accordance with the terms of this Agreement. In the event that the Escrow Agent fails to make the necessary demand on the assurance as set forth above, the Division shall have the right to then make the demand on the assurance in accordance with the terms of this Agreement and such funds shall thereafter be placed in escrow pursuant to the terms of this Agreement. It is understood that this procedure shall be similarly followed in the event of any dispute with any purchaser relating to refunds of any funds secured by the assurance from time to time that is not resolved within fifteen (15) days from the date that Developer receives notice of dispute. Developer shall deposit all funds required to be escrowed at least fifteen (15) days prior to the expiration of the alternative assurance.
- (e) If Escrow Agent is required under Section 718.202, Florida Statutes, or under the provisions of a Contract to refund a purchaser's deposit(s), Escrow Agent shall do so to the extent of Escrow Agent's available funds, within three (3) business days after receipt of the request for same. If Escrow Agent does not have sufficient funds remaining in its respective Escrow Accounts to refund to the purchaser his or her deposits, then Developer shall, within fifteen (15) days after receipt of such notification from Escrow Agent, pay to Escrow Agent such sums as may be necessary to permit Escrow Agent to make the required refund. If Developer

fails to furnish such sums to Escrow Agent within this fifteen (15) day period, the following provisions shall apply: (i) Escrow Agent shall refund to purchaser such portion, if any, of his or her deposits in excess of ten percent (10%) of the sales price as remains in the Special Escrow Account, Developer being responsible for payment of any deficiency therein; and (ii) Escrow Agent shall refund to purchaser such portion of his or her deposits as do not exceed ten percent (10%) of the sales price from the funds, if any, remaining in the Ten Percent Escrow Account. If the funds in the Ten Percent Escrow Account are insufficient to make such refund, Escrow Agent or the Division shall be entitled to draw, in accordance with the procedures set forth in subsection 6(d) above, on any outstanding letter(s) of credit or surety bond or other assurance for a sum in the aggregate not to exceed the amount necessary to make a full refund of the purchaser's deposits up to ten percent (10%) of the Contract sales price. Funds previously released to Developer, which are secured by any assurance may be released from the assurance upon cancellation by a purchaser upon presentation to Escrow Agent of an affidavit stating that the Developer has fully refunded purchaser in accordance with the terms of the purchase agreement. The Escrow Agent and the Division shall not draw on any letter(s) of credit or surety bond except to the extent necessary to provide refunds due purchasers of their deposits up to ten percent (10%) of their respective sales prices. The Escrow Agent and the Division shall not draw upon any letter of credit or surety bond for the purpose of obtaining funds with which to make refunds to purchasers of deposits in excess of ten percent (10%) of the respective unit sales prices. The parties agree that the issuer of any letter of credit or surety bond is a third party beneficiary of the preceding two (2) sentences.

- (f) The parties acknowledge that as Contracts are closed or otherwise terminated the aggregate sum of the letter(s) of credit and/or surety bond issued and outstanding pursuant to this Agreement may exceed the total amount of outstanding deposits for which such letter(s) of credit and/or surety bond were given as security. Whenever such circumstance exists, and provided Developer is not otherwise in default of any of its obligations hereunder, Developer shall be entitled to reduce the aggregate sum of such letter(s) of credit and/or surety bond by: (i) terminating one or more of the letters of credit, if any, upon notification to issuer, Escrow Agent, and the Division, pursuant to the terms of this Agreement, so that the remaining letter(s) of credit will in the aggregate equal an amount which is the same or in excess of the total of all Withdrawn Funds; or (ii) delivering to the Escrow Agent, with a copy to the Division, new or replacement letter(s) of credit and/or surety bond(s), to replace the outstanding letter(s) and/or bond(s), in an amount at least equal to the total of all Withdrawn Funds; or (iii) amending the existing letter(s) of credit and/or surety bond and delivering same to the Escrow Agent, with a copy to the Division. Any new letter(s) of credit and/or surety bond delivered pursuant to this paragraph shall meet all requirements of the Act. Notwithstanding anything herein contained to the contrary, funds retained by Developer from Initial 10% Deposits which are secured by the assurance may only be released from the assurance upon presentation to Escrow Agent of certification from Developer that the conditions listed in Section 718.202(1), Florida Statutes, have been met.
- (g) Upon receipt of new letter(s) of credit and/or surety bonds in the amount and in the form prescribed herein, Escrow Agent agrees to (i) terminate the prior letter(s) of credit and/or surety bonds being replaced and accept the new letter(s) of credit and/or surety bonds in full substitution therefor, and (ii) surrender to the issuer of a new letter of credit and/or surety bond any prior letter(s) of credit and/or surety bond properly designated therein. Any such new letter of credit or surety bond shall require the approval of the Division as otherwise provided herein. In the event that the issuer of a letter of credit or surety bond gives notice that the letter(s) of credit and/or surety bond will not be renewed beyond the term then in effect, Developer shall, at least forty-five (45) days prior to the expiration date of such letter of credit and/or surety bond, furnish to Escrow Agent either cash or a new letter of credit or surety bond in an amount which, when combined with the amount of all other outstanding letters of credit and/or surety bonds delivered to the Escrow Agent under this Agreement, equals or exceeds the Withdrawn Funds. The Division shall either advise Escrow Agent and Developer of its approval of any letter of credit or surety bond delivered to it or it shall return such letter of credit or surety bond to Developer together with its written explanation of any deficiencies. If there are any deficiencies noted, Developer shall provide a replacement letter of credit or surety bond correcting the stated deficiencies so that the Division will issue its written approval of same in accordance herewith as a condition to the disbursement of any amounts from the Ten Percent Escrow Account to Developer. Developer shall provide to Escrow Agent a copy of the Division's approval of a new letter of credit or surety bond prior to drawing any previously undisbursed escrowed funds covered thereby.
- (h) If an alternative assurance is no longer required in order to enable Developer to satisfy the conditions set forth in the Condominium Act and the provisions of this Agreement and Developer desires to terminate the alternative assurance, Developer shall so notify Escrow Agent, the Division and the issuer of the assurance in writing by certified mail at least forty five (45) days in advance of the expiration date of the applicable assurance and Escrow Agent shall thereafter return the assurance to the issuer. For purposes hereof, the expiration date of any assurance which is automatically renewable shall be extended by the applicable renewal periods unless Escrow Agent receives notice from the issuer that the issuer will not renew the assurances. Developer shall provide written instructions to Escrow Agent and Division for handling return of original assurances. Escrow Agent is authorized to rely upon a statement from Developer as to whether alternative assurances are no longer required to satisfy the conditions set forth in the Condominium Act and herein.

7. Escrow Agent has no liability in the event of the refusal of the issuer of any letter of credit or surety bond to honor drafts drawn on such letter of credit, or the failure of any bonding company to disburse funds under any bond. Further, Escrow Agent has no liability for the obligations of the Division or the Developer hereunder.

8. Notwithstanding anything contained herein to the contrary, the total funds held by Escrow Agent in the Ten Percent Escrow Account plus the balance of all outstanding and unexpired letter(s) of credit and/or surety bonds delivered to the Division and approved by it hereunder must at all times be equal to or in excess of all purchasers' deposits originally paid to Escrow Agent up to ten (10%) percent of the purchase price under each Contract, less the amount of each purchaser's deposit paid to or retained by purchaser or Developer as a consequence of default, termination, or closing, or as otherwise provided in this Agreement.

9. Escrow Agent shall keep an accurate account of all deposits received by it for deposit to either the Ten Percent Escrow Account or the Special Escrow Account, and the disposition hereof. Escrow Agent shall notify the Division in writing of the termination of any letter of credit or surety bond resulting from the occurrence of one or more of the events specified hereunder. In addition, but subject to and limited by any governmental or regulatory restrictions imposed on Escrow Agent and its books and records, the Division shall have the right to inspect Escrow Agent's books and records regarding the Escrow Accounts, provided, however, that the Division conducts such inspection in a reasonable manner during the normal working hours of Escrow Agent and after giving written notice to Escrow Agent of its exercise of such right, which notice shall be given at least five (5) days prior to the inspection.

10. Escrow Agent may act in reliance upon any writing, instrument or signature which it, in good faith, believes to be genuine, may assume the validity and accuracy of any statements or assertions contained in such writing or instrument and may assume that any person purporting to give any writing, notice, advice or instruction in connection with the provisions hereof has been duly authorized to do so. Escrow Agent shall not be liable in any manner for the sufficiency or correctness as to form, manner of execution, or validity of any written instructions delivered to it, nor as to the identity, authority, or rights of any person executing the same. The duties of Escrow Agent shall be limited to the safekeeping of the deposits and the disbursement of same in accordance with the written instructions described above. Escrow Agent undertakes to perform only such duties as are expressly set forth herein, and no implied duties or obligations shall be read into this Agreement against Escrow Agent. Upon Escrow Agent disbursing the deposit of a purchaser in accordance with the provisions hereof, the escrow shall terminate with respect to said purchaser's deposit, and Escrow Agent shall thereupon be released of all liability hereunder in connection therewith.

11. The alternative assurances may cover sales of units at other condominium projects being developed by Developer. In the event that an assurance and this Agreement is amended to cover sales of units at other Condominiums, the Division shall be furnished with a copy of such original amendment to the assurance and this Agreement. Developer shall deliver to the Escrow Agent a copy of the Division's written approval of the use of the assurance for such projects in addition to the reporting requirements described herein.

12. Escrow Agent may consult with counsel of its own choice and shall have full and complete authority and protection for any action taken or suffered by it hereunder in good faith and in accordance with the opinion of such counsel. Escrow Agent shall not be liable for any mistakes of fact or errors of judgment, or for any acts or omissions of any kind unless caused by its misconduct or gross negligence, and Developer agrees to indemnify and hold Escrow Agent harmless from and against any claims, demands, causes of action, liabilities, damages, judgments, including the cost of defending any action against it together with any reasonable attorneys' fees incurred therewith, in connection with Escrow Agent's undertaking pursuant to the terms and conditions of this Escrow Agreement, unless such action or omission is a result of the misconduct or gross negligence of Escrow Agent.

13. In the event of a good faith disagreement about the interpretation of this Agreement, or about the rights and obligations, or the propriety, of any action contemplated by Escrow Agent hereunder, Escrow Agent may, at its sole discretion, file an action in interpleader to resolve said disagreement. Escrow Agent shall be indemnified by Developer for all costs, including reasonable attorneys' fees, in connection with the aforesaid interpleader action.

14. Escrow Agent may resign at any time upon the giving of thirty (30) days' written notice to Developer and the Division. If a successor to Escrow Agent is not appointed within thirty (30) days after notice of resignation, Escrow Agent may petition any court of competent jurisdiction to name a successor escrow agent and Escrow Agent shall be fully released from all liability under this Agreement to any and all parties, upon the transfer of the escrow deposit to the successor escrow agent either designated by Developer or appointed by the Court. The successor escrow agent must be authorized to act as such by the Florida Condominium Act.

15. Developer shall have the right to replace Escrow Agent upon thirty (30) days' written notice with a successor escrow agent named by Developer. Developer shall give written notice to the Division of the replacement of the escrow agent and any replacement escrow agreement and the new escrow agent and/or new escrow agreement shall be subject to the approval of the Division. In the event the new escrow agent is approved by the Division and Escrow Agent is so replaced, Escrow Agent shall turn over to the successor escrow agent all funds, documents, records and properties deposited with Escrow Agent in connection herewith and thereafter shall have no further liability hereunder. The successor or other escrow agent must be authorized to act as such by the Florida Condominium Act.

16. This Agreement shall be construed and enforced according to the laws of the State of Florida and this Agreement may be made a part, in its entirety, of any prospectus, offering circular or binder of documents distributed to purchasers or prospective purchasers of condominium units in the Condominium.

17. This Escrow Agreement shall be expressly incorporated by reference in all Contracts between Developer and purchasers and a copy delivered to purchasers at the time of execution of their purchase agreement.

18. As used in this Escrow Agreement, interest will be deemed earned on a specific deposit at the rate which is the average for all deposits held hereunder over the period the specific deposit is held.

19. This Amendment may be executed in any number of counterparts and by the separate parties hereto in separate counterparts, each of which when taken together shall be deemed to be one and the same instrument.

20. Developer hereby agrees to pay the Escrow Agent, in arrears, a fee equal to One Hundred Twenty Five (\$125.00) Dollars for each new Contract for which the Escrow Agent is holding a deposit, provided that only one such fee shall be paid with respect to any one Contract regardless of the amount of activity (i.e., deposits and withdrawals) with respect to that Contract. The Escrow Agent shall invoice Developer as to all new Contracts for which deposits were received in the previous calendar month, Developer shall pay the applicable fee(s) within thirty (30) days following receipt of invoice.

21. This Agreement represents the entire agreement between the parties with respect to the subject matter hereof and shall be binding upon the parties, their respective successors and assigns.

**** SIGNATURES ARE PROVIDED ON THE FOLLOWING PAGE ****

IN WITNESS WHEREOF, the parties have executed this Agreement on the day and year first above written.

FONTAINEBLEAU FLORIDA TOWER 3, LLC, a Florida limited liability company

By: Fontainebleau Florida Hotel Properties, LLC, a Florida limited liability company, Sole Member

By: Fontainebleau Resort Properties I, LLC, a Delaware limited liability company, Sole Member

By: Fontainebleau Resort Holdings, LLC, a Delaware limited liability company, Sole Member

By: Fontainebleau Resorts, LLC, a Delaware limited liability company, Sole Member

By: Soffer Fontainebleau Associates Limited Partnership, a Florida limited partnership, Sole Member

By: Fontainebleau Resorts Managing Member, LLC, a Florida limited liability company, General Partner

By: 
Jeffrey Soffer, Manager

CHICAGO TITLE INSURANCE COMPANY

By:
Name:
Title:

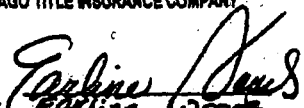
Carline Wood
Branch Manager

NOTICE OF ESCROW DEPOSIT
FONTAINEBLEAU III OCEAN CLUB CONDOMINIUM

Date: _____

Chicago Title Insurance Company
2701 Gateway Drive
Pompano Beach, FL 33069

Attn: _____

Re: Purchase of Unit No. ____ In FONTAINEBLEAU III OCEAN CLUB CONDOMINIUM

Gentlemen:

The purchaser(s) named below has entered into an Agreement for Sale for the above-referenced Condominium Unit and we deliver herewith a deposit of \$ _____ in accordance with the Agreement for Sale.

Name of Purchaser(s): _____

Mailing Address of
Purchaser(s):

Social Security Number(s)
of Purchasers:

RECEIPT

Receipt is acknowledged of the above deposit, subject to clearance of said funds, if a check.

CHICAGO TITLE INSURANCE COMPANY

By: _____

Date of Receipt:

Exhibit "E"

**Greenberg
Traurig**

*Gary A. Saul
(305) 579-0846*

E-MAIL: SAULG@GTLAW.COM

March 30, 2005

TO WHOM IT MAY CONCERN

Re: **Fontainebleau III Ocean Club Condominium**

Ladies and Gentlemen:

This letter is intended to confirm that this law firm serves as legal counsel to FONTAINEBLEAU FLORIDA TOWER 3, LLC, a Florida limited liability company, which is the developer of the above-referenced proposed Condominium, to be located in Miami Beach, Florida. This letter shall further confirm that the property is under contract to be acquired by an affiliate of the developer, and the affiliate has a contractual interest in the property which is intended to be developed as the Condominium and intends to transfer title to the developer prior to the creation of the Condominium.

Sincerely,

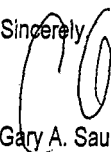
Gary A. Saul

ALBANY
AMSTERDAM
ATLANTA
BOCA RATON
BOSTON
CHICAGO
DALLAS
DENVER
FORT LAUDERDALE
LOS ANGELES
MIAMI
NEW JERSEY
NEW YORK
ORANGE COUNTY
ORLANDO
PHILADELPHIA
PHOENIX
SILICON VALLEY
TALLAHASSEE
TYSONS CORNER
WASHINGTON, DC
WEST PALM BEACH
WILMINGTON
ZURICH

Exhibit "F"

**DECLARATION OF RESTRICTIONS AND
RECIPROCAL EASEMENT AGREEMENT**

BETWEEN

FONTAINEBLEAU FLORIDA HOTEL, LLC,
as Hotel Owner,

and

FONTAINEBLEAU FLORIDA TOWER 3, LLC,
as Tower Building Owner

FONTAINEBLEAU HOTEL AND TOWER 3 BUILDING

Note to Recorder: Only nominal consideration was paid for the easements granted hereby and, accordingly, only minimal documentary stamp tax and surtax are due.

This instrument prepared by
and when recorded return to:
Arnold A. Brown, Esq.
Bilzin Sumberg Baena
Price & Axelrod LLP
2500 Wachovia Financial Center
200 South Biscayne Blvd.
Miami, Florida 33131-2336

Return to:
Lori R. Hartglass, Esq.
Turnberry Associates
19501 Biscayne Boulevard, Suite 400
Aventura, FL 33180

**DECLARATION OF RESTRICTIONS AND
RECIPROCAL EASEMENT AGREEMENT**

This Declaration of Restrictions and Reciprocal Easement Agreement (the "Agreement") is made and entered into as of this ___ day of _____, 2005 by Fontainebleau Florida Hotel, LLC, a Florida limited liability company ("Hotel Owner"), whose address is 19501 Biscayne Blvd., Suite 400, Aventura, Florida 33180, and Fontainebleau Tower 3, LLC, a Florida limited liability company, ("Tower Building Owner"), whose address is 19501 Biscayne Boulevard, Suite 400, Aventura, Florida 33180.

WHEREAS, Hotel Owner is the owner of a certain parcel of real property located in Miami-Dade County, Florida, legally described on Exhibit "A" attached hereto and made a part hereof (the approximate location of which is noted by bold dashed lines on Exhibit "D" attached hereto and made a part hereof), and the improvements located thereon (the "Entry/Garage Space"); and

WHEREAS, Tower Building Owner is the owner of, those certain parcels of real property located above, and to the north and east of, portions of the Entry/Garage Space in Miami-Dade County, Florida, legally described on Exhibit "B" attached hereto and made a part hereof (the "Tower Building"; the Tower Building and the Entry/Garage Space are herein collectively referred to as the "Property"), Tower Building Owner having acquired same from Hotel Owner; and

WHEREAS, Hotel Owner is also the owner of certain parcels of real property located to the north, west and east, as well as on the west side of Collins Avenue, in Miami-Dade County, Florida, adjacent to the Property, legally described on Exhibit "C" attached hereto and made a part hereof, and the improvements located thereon (the "Hotel Space"), which Hotel Space includes those certain parcels of real property, and the improvements thereon, referred to as the Entry/Garage Space and Spine, as defined in the Amended and Restated Declaration of Restrictions and Reciprocal Easement Agreement recorded in Official Records Book 22955, Page 1284, of the Public Records of Miami-Dade County, Florida (the "REA"), and located to the north and west of, and

adjacent to, the Property (the "Tower 2 Garage" and "Spine", respectively); and

WHEREAS, TL Fontainebleau Tower Limited Partnership ("Tower 2 Owner"), an affiliate of Tower Building Owner, owns the air rights parcel of real property legally described on Exhibit "B" to the REA, and the improvements located thereon ("Tower 2"); and

WHEREAS, Tower Building Owner and Hotel Owner (hereinafter collectively referred to as the "Parties" and each of which is individually referred to as a "Party") acknowledge that, for land use and zoning purposes, the Property, Tower 2 and the Hotel Space will be considered as a single parcel, to be developed substantially in accordance with the site plan approved pursuant to the land development regulations of the City of Miami Beach and the permits from time to time issued for work on the Property, Tower 2 and the Hotel Space, as the same may from time to time be modified, subject to the provisions contained herein; and

WHEREAS, the Parties contemplate that Tower Building Owner shall construct (or has constructed) the "Permitted Improvements" (as defined in subparagraph 12(h)) upon the Entry/Garage Space, the Hotel Space and the Tower Building and, accordingly, they are desirous of (i) establishing certain easements, licenses and/or rights in, to, over, across, under and through portions of the Entry/Garage Space, the Hotel Space and the Tower Building and (ii) imposing certain restrictions in connection with the development and use of the Entry/Garage Space, the Hotel Space, and the Tower Building, all as more particularly provided for herein;

NOW, THEREFORE, for \$10.00 and other good and valuable consideration, the receipt and sufficiency of which are hereby acknowledged, the Parties do hereby declare as follows:

1. Establishment of Easements within Property. Hotel Owner does hereby establish, create and grant to Tower Building Owner perpetual non-exclusive (except as and to the extent expressly provided to the contrary herein) easements in, to, over, across, under and through those portions of the Entry/Garage Space specified in this paragraph, for the purposes contemplated in this paragraph, for the use and benefit of the respective owners and guests of the Hotel Space and the Tower Building, and portions thereof, and their employees, agents, customers, guests, licensees, invitees (including, without limitation, fire, police and other emergency personnel), tenants, mortgagees, successors and assigns. The scope, nature and extent of the easements described in this paragraph shall be as follows:

(a) All portions of the Entry/Garage Space that are during and immediately after completion of the Initial Construction, as defined in subparagraph 12(h), utilized for support of any portion of the Tower Building (including, without limitation, footings, foundations and lateral, overhead and subjacent support), as same may from time to time be relocated, constructed or reconstructed in accordance with the terms of this Agreement.

(b) During construction of the Permitted Improvements, but not thereafter, all portions of the Entry/Garage Space as may be reasonably required for construction and development of the Permitted Improvements, including, without limitation, any and all utility installations, mechanical equipment, landscaping and/or other installations serving and/or benefiting same.

(c) All portions of the Entry/Garage Space as may be reasonably required for access to support columns (including, without limitation, footings and foundations), beams, slabs, shear walls, vent and other shafts, meter rooms, storage rooms, stairwells, party walls, ceilings and floors, utility, fire safety, communications, security and similar facilities (including closed circuit television lines), emergency generator, sump pumps and lift stations, discharge wells, grease traps, HVAC equipment and other building components from time to time located within the Entry/Garage Space and benefiting the Tower Building, together with the right to initially install and thereafter inspect, maintain, repair, reconfigure, shore, construct, reconstruct and replace same in accordance with the terms of this Agreement. The foregoing easement for access shall also exist for the purposes of (i) permitting Tower Building Owner reasonable access to portions of the Hotel Space that abut portions of the Entry/Garage Space as may reasonably be required for such access and (ii) permitting Tower Building Owner to reasonably exercise the easement and other rights granted in this subparagraph and elsewhere in this Agreement.

(d) All portions of the Entry/Garage Space that are immediately after completion of the Initial Construction utilized for ducts, conduits or other utility, fire safety, security or similar facilities for water, air, ventilation, smoke evacuation, fire safety/sprinkling (including stand pipes, fire pumps and control valves, fire and enunciator panel(s) and related facilities), emergency generator, air conditioning (including refrigerant lines, chilled water lines, electric lines, thermostatic control lines and related facilities), gas, steam, electricity, energy, drainage, sewage, grease, communications, security and utilities (including closed circuit television lines) within the Entry/Garage Space and benefiting the Tower Building, together with the right to initially install and thereafter inspect, maintain, repair, reconfigure, shore, construct, reconstruct and replace same.

(e) All portions of the Entry/Garage Space that immediately after completion of the Initial Construction consist of party walls (including party floors and ceilings), as same may be reconstructed, all portions of the Entry/Garage Space on which encroachments of the Tower Building into the Entry/Garage Space (or of the Entry/Garage Space into the Tower Building, for which an easement is granted for the benefit of the Entry/Garage Space) exist immediately after completion of the Initial Construction, and all portions of the Property (for which an easement is granted for the benefit of the Entry/Garage Space, as well as for the benefit of the Tower Building) on which minor unintentional encroachments arising from construction or reconstruction as permitted by this Agreement or caused by settling or shifting may from time to time hereafter exist.

(f) The emergency stairwells within the Entry/Garage Space that exit at ground level, as same may be reconstructed as permitted by this Agreement for pedestrian ingress and egress.

(g) Any and all elevator shaft(s), cabs, doors and elevator equipment room(s) that are located within or run through the Entry/Garage Space and service the Tower Building (the "Elevators"), as same may be reconstructed as permitted by this Agreement, together with reasonable access thereto (Hotel Owner may, at its option, from time to time at any time install a lock(s) which blocks access from such Elevators, or any of them, into the parking garage comprising a portion of the Entry/Garage Space during late night, early mornings or other hours).

(h) The trash room and mail room to be located immediately after the Initial Construction on the basement level and lower lobby level, respectively, of the Entry/Garage Space, which trash room and mail room are intended to serve solely the Tower Building and in respect of which the Tower Building is granted the exclusive right to use, as same may be reconstructed or relocated as permitted by this Agreement, and for reasonable access thereto, for the use and benefit of same.

(i) All portions of the Entry/Garage Space from time to time located outside of the exterior walls of the buildings constructed on the Property, for pedestrian and vehicular ingress and egress of persons between the Tower Building and the adjacent public streets and sidewalks, as same may be reconstructed or relocated as permitted by this Agreement.

(j) Those portions of the parking garage comprising a portion of the Entry/Garage Space, that are from time to time (i) available to the Tower Building pursuant and subject to the provisions of paragraph 10 for parking or (ii) required by Tower Building Owner for access to such parking.

(k) The trash chute(s), any self-service laundry room, any pantry, the chiller room, the pool pump room and the storage rooms to be located immediately after the Initial Construction in the service areas of the Entry/Garage Space, and the pool deck (including landscape and water features thereon or adjacent thereto), all of which are intended to serve solely the Tower Building and in respect of which the Tower Building is granted the exclusive right to use, as same may be reconstructed or relocated as permitted by this Agreement, and for reasonable pedestrian and vehicular access thereto, for the use and benefit of same.

Attached hereto as Exhibit "D" is a site plan that generally depicts the locations of the various areas described above and the general allocation of the costs of maintenance (i.e. by Hotel Owner without contribution from Tower Building Owner, by Tower Building Owner without contribution from Hotel Owner or by one Party with contribution by the other). Such Exhibit "D" is attached for illustrative purposes only, and shall not serve to modify the provisions of this Agreement:

2. Establishment of Easements/Rights Between the Tower Building and the Hotel Space.

(a) Hotel Owner does hereby establish, create and grant to Tower Building Owner non-exclusive perpetual easements, for the use and benefit of the respective guests/occupants of both the Hotel Space, Tower 2 and the Tower Building, and portions thereof, over, under and upon those portions of the Hotel Space as may from time to time, in the sole discretion of Hotel Owner, be made available to all hotel guests of the hotel operated on the Hotel Space, including, without limitation, the Spine, and the exterior grounds of the Hotel Space and all amenities thereof (e.g. pools, health clubs and spa), to the same extent, and subject to the same restrictions and limitations (including amounts and terms of payment), as guests of the hotel operated on the Hotel Space are afforded. The foregoing includes, without limitation, the right of reasonable pedestrian and vehicular access to fire, police and other emergency personnel.

(b) Hotel Owner does hereby further covenant and agree to provide to the Tower Building such services as are from time to time in the sole discretion of the Hotel Owner afforded to guests of the hotel operated on the Hotel Space, such as, without limitation, housekeeping, food and beverage services, as well as personal services (such as dry cleaning and in room massage, if available), to the same extent, and subject to the same restrictions and limitations (including amounts and terms of payment), as guests of the hotel operated on the Hotel Space are afforded. Notwithstanding the foregoing, from and after the date that the Tower Building is subjected to the condominium form of ownership, if ever, owners of individual units in the Tower Building (and those occupying such units

with the owners permission) shall (i) not be charged an admittance fee or similar charge for access to any spa facility (but this waiver shall not apply to charges for specific spa facility services, such as massage) and (ii) be charged a fee to be determined by Hotel Owner in its reasonable business judgment (which, absent manifest error, shall be conclusive) to cover the costs of any housekeeping services, if any, from time to time made available by Hotel Owner to, and desired by, such owner(s) or those occupying with their permission; provided that the provisions of this sentence shall not apply to any occupant of a unit pursuant to any rental program.

(c) Hotel Owner does hereby establish, create and grant to Tower Building Owner temporary non-exclusive easements, while initial construction or future rebuilding of portions of the Property is ongoing, in, to, over, across, under and through those portions of the Hotel Space (i) in the vicinity of the Property and (ii) not improved with buildings or other structures and (iii) reasonably approved in advance by Hotel Owner for the purpose of access, staging and otherwise facilitating Initial Construction and future rebuilding of the Property or portions thereof by Tower Building Owner, for the use and benefit of the Tower Building Owner and those performing work on its behalf in connection with Initial Construction or future rebuilding of the Property, or portions thereof. The easement rights granted in this subparagraph and in subparagraph (d) below are subject to such reasonable requirements as Hotel Owner may impose including, without limitation, the prior reasonable approval of all work to be performed in the easement areas and the timing for effecting same, the furnishing of reasonably appropriate insurance, the furnishing of reasonable evidence of the availability of funds needed to complete the contemplated building or rebuilding and restore the Hotel Space to its pre-existing condition after such completion and the establishment and enforcement of procedures by Tower Building Owner to protect persons and property of Hotel Owner and its guests, employees and invitees, while on the Hotel Space and to minimize inconvenience to and disruption of the business operated on the Hotel Space (which will include, among other things, the installation of appropriate barricades, which Hotel Owner may require to be finished with suitable exterior finish material for aesthetic purposes, if the barricades will be in place long term).

(d) Hotel Owner does hereby establish, create and grant to Tower Building Owner perpetual non-exclusive easements in, to, over, across, under and through those portions of the Hotel Space not improved with buildings or other structures that are reasonably required for the purpose of connecting to existing public utility facilities that are contemplated to be shared by the Hotel Space and the Property (and for the purpose of maintaining, repairing and replacing such connections or installations), and potentially Tower 2, together with reasonable access over those portions of the Hotel Space not improved with building or other structures to implement such

connections, for the use and benefit of Tower Building Owner and those engaged by it to perform such work.

(e) Hotel Owner does hereby establish, create and grant to Tower Building Owner perpetual non-exclusive easements in, to, over, across, under and through those portions of the Hotel Space as may be reasonably required for connection and access to fire safety, communications, security and similar facilities, together with the right to initially install and thereafter inspect, maintain, repair, reconfigure, construct, reconstruct and replace same in accordance with the terms of this Agreement. It is anticipated that some or all of the fire safety, communications, security and similar facilities serving the Tower Building will be interconnected to the systems serving the Hotel Space (even though such systems will be designed as stand alone systems for the Tower Building), and the foregoing easement is given in recognition of this. Notwithstanding the foregoing, no such interconnection will be effected unless approved by Hotel Owner in its sole discretion (and, once approved, Hotel Owner may, thereafter, from time to time, rescind such approval, subject to compliance with applicable governmental requirements and the condition that the Tower Building will retain a fully operational system after any such rescission). This easement shall be inapplicable at all times when interconnection as aforesaid is not approved by, or has been rescinded by, Hotel Owner.

(f) All portions of the Tower 2 Garage that are from time to time reasonably required for pedestrian and vehicular ingress and egress of persons between the Tower Building and the adjacent public streets and sidewalks, as same may be reconstructed or relocated as permitted by this Agreement.

(g) Those portions of the parking garage comprising a portion of the Tower 2 Garage, that are from time to time required by Tower Building Owner for access to the parking pursuant and subject to the provisions of paragraph 10.

(h) [To be modified based on architect input] Hotel Owner does hereby establish, create and grant to Tower Building Owner perpetual non-exclusive easements in, to, over, across, under and through the loading and/or freight dock or docks, including ancillary facilities such as engineering shop, security office, receiving area and storage areas (the "Freight Dock"), to be located immediately after the Initial Construction under the REA on the ground level of the Entry/Garage Space as defined in the REA, as same may be reconstructed or relocated as permitted by the REA or this Agreement (and as same may be expanded in number or size from time to time at the sole option of Hotel Owner), and for reasonable pedestrian and vehicular access thereto, for the use and benefit of same.

(i) [To be modified based on architect input] Hotel Owner does hereby establish, create and grant to Tower Building Owner perpetual non-exclusive easements in, to, over, across, under and through the compactor space (the "Compactor Space") and the trash elevator and vestibule (the "Trash Elevator") to be located immediately after the Initial Construction under the REA on the ground level, ground level and lower level, respectively, of the Entry/Garage Space as defined in the REA, as same may be reconstructed or relocated as permitted by this Agreement, and for reasonable pedestrian and vehicular access thereto, for the use and benefit of same.

(j) Tower Building Owner hereby grants to Hotel Owner, its successors and assigns, a perpetual license, appurtenant to the Hotel Space, to install, maintain and replace promotional materials and signage for the Hotel Space (and the occupants thereof) within the Tower Building, in public areas devoted to same (such as in the elevators, lobbies and hallways), as such areas may be changed from time to time in the discretion of Tower Building Owner (but subject to the other terms of this Agreement). Hotel Owner agrees that all such promotional material shall be tasteful, professionally prepared and maintained in good condition at no cost to Tower Building Owner.

3. Agreement to Grant Additional Easements. If additional easements between portions of the Property, and/or between portions of the Property and the Hotel Space, are reasonably necessary to effectuate the purposes of this Agreement, provided said proposed easements or additional easements will not unreasonably interfere with the use and occupancy of any portion of the Property or Hotel Space to be burdened by the proposed easements or additional easements, unreasonably affect access to, or the operation of, any portion of the Property or Hotel Space to be burdened by the proposed easements or additional easements or unreasonably increase the operating cost of, or create any other additional expense for, the portion of the Property or Hotel Space to be burdened by the proposed easements or additional easements, each Party hereby agrees to use their best efforts to agree upon, determine and grant such easements or additional easements. No abandonment of any of the easements created by this Agreement shall be deemed to exist in the absence of a written agreement by both Parties; provided, however, that each Party agrees to execute such a written agreement promptly upon demand of the other Party at such time, if any, as any of the easements created by this Agreement are no longer needed and not reasonably anticipated to be needed in the future in connection with construction, reconstruction or restoration as permitted by this Agreement. There shall be no merger of the easements created by this Agreement and fee title to any portion of the Property or Hotel Space in the absence of a written agreement executed by the holders of all such interests.

4. Limitations on Use of the Property and Easement Areas.

(a) No Barriers. No barriers will be erected which would have the effect of limiting or restricting the easement or license rights granted herein; provided, however, that reasonable nondiscriminatory and consistently enforced rules and regulations may be established by the owner(s) from time to time of the Entry/Garage Space (or Hotel Space, if applicable), or portions thereof, related to the use of the easement and/or other areas located on their respective portions of the Entry/Garage Space (or Hotel Space, if applicable). Without limiting the generality of the foregoing, (i) employees and contractors engaged to work in the Tower Building shall be required to comply with the security checkpoint and other security procedures from time to time established by Hotel Owner and (ii) nothing herein contained shall preclude either Party from installing devices (such as locks or computer entry cards) that will prohibit or limit access into space wholly owned by that Party from stairwells, elevators and other areas with respect to which easement rights to the other Party have been granted.

(b) Conduct of Work. All work performed in easement areas shall be performed in a prompt, good, workmanlike, first class, lien-free manner, and in a manner which minimizes disruption of or interference with the operation of all portions of the Property, Tower 2 and the Hotel Space. From and after initial construction of the Permitted Improvements, any construction activity by a Party within an easement area not owned by it shall require at least 48 hours written notice to the other Party, except in the case of an emergency when only such notice as is reasonable under the circumstances shall be required. Any work performed by either Party in any easement area not owned by it shall, once commenced, be performed continuously and with due diligence and, promptly upon completion thereof, the area in which the work was performed, and any other areas affected thereby, shall be restored to at least the condition that they were in prior to the performance of such work.

(c) Plans Availability. Each Party shall retain all plans and specifications for the portion of the Property or Hotel Space owned by it, to the extent in its possession or control, including plans and specifications for work that is hereafter from time to time performed on its portion of the Property or Hotel Space, and shall make same available to the other Party and to Tower 2 Owner from time to time upon reasonable request therefor (and the other Party and Tower 2 Owner may duplicate any such materials, at its cost). The foregoing is agreed to in recognition of the fact that such materials may facilitate the maintenance, repair and replacement of facilities within the Property or Hotel Space. Each Party disclaims any representation or warranty as to the accuracy of any such materials.

(d) Freight Docks, Trash Elevator and Compactor Space. The Tower Building, Tower 2 and the Hotel Space shall each have the right to use the Freight Dock, the Trash Elevator and the Compactor

Space, subject to scheduling and other reasonable, nondiscriminatory and consistently enforced rules and regulations as may from time to time be established by Hotel Owner.

(e) Compliance with Legal Requirements. Anything contained in this Agreement to the contrary notwithstanding, each Party will at all times while this Agreement is in effect promptly and fully comply with all Legal Requirements that pertain to the portion of the Property owned by it, whether or not any such Legal Requirements shall necessitate structural changes or improvements to or interfere with the use and enjoyment of the portion of the Property owned by it; provided, however, that any changes to items with respect to which one Party has exclusive rights (if any) or required to a portion of the Property owned by one Party as a result of improvements, changes or alterations being performed by the other Party shall be the responsibility of the Party who has the exclusive right of use or causing the need for the improvements, changes or alterations, as applicable. "Legal Requirements" shall mean (i) all present and future laws, ordinances, orders, rules, regulations and requirements of all federal, state, county and municipal governments, departments, commissions, boards and courts, and rules and regulations of any insurance rating organization or any other body exercising similar functions, foreseen or unforeseen, ordinary as well as extraordinary, which may be applicable to the Property or the sidewalks and curbs adjoining the Property or to the use or manner of use of the Property by the owners, tenants, or occupants thereof, including the Americans with Disabilities Act; and (ii) the requirements of all public liability, fire and other policies of insurance at any time in force with respect to the Property; and (iii) the provisions of any restrictive covenants now or hereafter affecting the Property. Each Party further agrees to cooperate with all reasonable requests of the other and Tower 2 Owner in respect of resolving issues pertaining to compliance with Legal Requirements.

(f) Cooperation. All easements and licenses granted in this Agreement, and the use thereof, shall be deemed to be limited to the extent reasonably necessary to accomplish the purposes for which such easements and licenses are granted. Each Party agrees to cooperate with the reasonable requests of the other and Tower 2 Owner in furtherance of the spirit and intent of the matters addressed in this Agreement.

(g) Effect of Exclusive Rights and Areas Primarily Used by One Party.

(i) Anything in this Agreement to the contrary notwithstanding, but subject to the remaining provisions of this subparagraph (g), for purposes of this Agreement, equipment, facilities or other items (if any) with respect to which a Party has exclusive rights shall be owned by such Party, and the Party in whose favor the exclusive rights run shall be responsible for all

obligations pertaining to the equipment, facilities and other items with respect to which such exclusive rights exist including, without limitation, maintenance, repair, replacement, injury to persons thereon, insurance and restoration after casualty or condemnation; the other Party shall have no obligations with respect thereto. The granting of exclusive rights to a Party for a particular purpose shall not preclude the other Party from utilizing the applicable portion of the Property that is affected by such exclusive rights for other purposes that are permitted by this Agreement and that do not adversely affect the exclusive rights granted by this Agreement to the other Party.

(ii) [Potentially to be modified based on architect input] Although the Elevators (excluding the elevator labeled "Shared Elevator" on Exhibit "D", which will be a shared cost under Article 6, and also excluding the elevator labeled "Hotel Elevator" on Exhibit "D" that will service primarily the "restaurant" in the Entry/Garage Space, which shall be operated, maintained, repaired, replaced and insured by Hotel Owner, without cost contribution), upper level lobby reception area and connector lobby, emergency generator(s) and fire pump(s) serving the Tower Building will be utilized by both the Tower Building and the Entry/Garage Space (and, as to freight elevators, emergency generator(s) and fire pump(s), potentially, a portion of the Hotel Space), given the overwhelming degree of use by the Tower Building, the Tower Building Owner is hereby charged with the exclusive obligation to operate, maintain, repair, replace and insure the then existing Elevators (including any communications equipment pertaining thereto), upper level lobby reception area and connector lobby, emergency generator(s) (including ancillary facilities such as fuel tank) and fire pump(s) or any replacement thereof as if the Tower Building had exclusive easement rights in respect thereof.

(iii) Inasmuch as the Freight Dock, Trash Elevator, Compactor Space and south entry/fountain feature serving the Tower Building will be available to be utilized by both the Tower Building, Tower 2 and portions of the Hotel Space, Hotel Owner shall (as provided for in subparagraph 4(g)(iii) of the REA) assume the obligation to operate, maintain, repair, replace and insure same or any replacement thereof, and the costs of doing so shall be shared by Hotel Owner, Tower 2 Owner and Tower Building Owner in proportion to the number of rooms in the Hotel Space, Tower 2 and Tower Building, respectively, that utilize the Freight Dock, Trash Elevator, Compactor Space and/or south entry/fountain feature from time to time (the sharing of costs shall be as reasonably determined by Hotel Owner and Designated Affiliate (as defined in Section 6(a)), which determination shall be conclusive in the absence of manifest unfairness). Sharing of costs based on the relative number of parking spaces allocated by applicable zoning regulations to the upper lobby level "restaurant", Tower 2 and the Tower Building shall be deemed reasonable.

(iv) Anything in this Agreement to the contrary notwithstanding, the Parties acknowledge that utility service for some systems, for purposes of engineering efficiency, were metered contrary

to the cost allocations otherwise provided for in this Agreement; and, accordingly, regardless of who has been allocated the responsibility for operating, maintaining, repairing, replacing and insuring specified items, and whether or not cost contribution is applicable in respect of specified items, the utility charges for the various systems shall be paid (and/or contribution toward the costs thereof paid) in accordance with the manner in which such systems are metered as part of Initial Construction (which contemplates four distinct meters for each applicable utility service, two solely for the Hotel Space (one for the upper level lobby "restaurant" and one for the balance of the Hotel Space), to be paid by Hotel Owner without contribution, a third solely for the Tower Building, to be paid by Tower Building Owner without contribution, and a fourth solely for the Entry/Garage Space (excluding the upper lobby level "restaurant"), to be paid by Hotel Owner with cost contribution), and neither Party shall be entitled to have any systems reallocated to another meter. Further, the allocations of the costs of operation, maintenance, repair and replacement in this Agreement may, in certain instances, be impractical to apply in respect of taxes and insurance; if Hotel Owner and Designated Affiliate reasonably determine that this is the case as to any specific allocations (which determination shall be conclusive in the absence of manifest unfairness), taxes and insurance shall be allocated as suggested by Hotel Owner and Designated Affiliate (which shall be conclusive in the absence of manifest unfairness) and any casualty damage shall be restored by the Party whose insurance covers the loss (or would cover the loss but for any deductible). In the event of a disagreement as to whether any given item or component is to be maintained solely at the cost of Hotel Owner, solely at the cost of Tower Owner, or is to be a shared cost, Hotel Owner and Designated Affiliate shall reasonably resolve the disagreement, which resolution shall be conclusive in the absence of manifest unfairness.

(v) The linen room(s) and linen chute(s) within the Entry/Garage Space, as well as those within the Tower Building (in respect of which the Hotel Owner has the exclusive right of use), shall be under the exclusive control of Hotel Owner, and shall be operated, maintained, repaired and replaced by Hotel Owner at its cost and Hotel Owner is granted non-exclusive easements in, to, over, across, under and through those portions of the Tower Building that are reasonably required to enable Hotel Owner to do so (including, without limitation, access rights thereto). The foregoing rights and obligations shall be automatically deemed assigned to and assumed by the Designated Affiliate, as hereinafter defined, at the time of the conveyance contemplated by paragraph 6(a) below. The utility and mechanical rooms within the Entry/Garage Space, shall be operated, maintained, repaired and replaced by Tower Owner at its sole cost, provided, however, that any facilities therein that serve solely the Hotel Space shall be operated, maintained, repaired and replaced by Hotel Owner at its sole cost and any facilities therein that serve solely the Entry/Garage Space shall be operated, maintained, repaired and replaced by Hotel Owner at a shared cost under Article 6.

(vi) Although the upper level lobby restrooms in the Entry/Garage Space will be utilized by both the Tower Building and the upper level lobby "restaurant" in the Entry/Garage Space, given the degree of use by said "restaurant", and in exchange for the Tower Building Owner being exclusively responsible for the upper lobby level reception area and connector lobby which will get extensive use from said "restaurant", the Hotel Owner is hereby charged with the exclusive obligation to operate, maintain, repair, replace and insure the then existing upper level lobby restrooms. The Parties agree that the foregoing allocation of responsibility for the upper level lobby restrooms and reception area/connector lobby, respectively, is an equitable allocation. Anything in this Agreement to the contrary notwithstanding, references in this Agreement or the Site Plan to a "restaurant" on the upper lobby level of the Entry/Garage Space shall not constitute a warranty that a restaurant will be located therein; Hotel Owner may from time to time in its sole discretion permit use of such area for any lawful purpose and Tower Building Owner shall have no right to object thereto.

5. Initial Construction/Renovations/Use.

(a) Standard of Work. In connection with construction, reconstruction, reconfiguration or renovation of any portion of the Property after the date hereof, all work performed shall be performed in a prompt, good, workmanlike, first class, lien free manner, and shall be accomplished so as to minimize disruption of (and, to the extent reasonably possible, not interrupt any) existing services to the then existing improvements on the Property and/or Hotel Space and in a manner so as to minimize inconvenience to and disruption of the owners and guests/occupants of then existing improvements on the Property and/or Hotel Space.

(b) Architectural Approval.

(i) No changes in the exterior appearance of any improvements comprising the Tower Building or in any public areas (such as elevators, lobbies and hallways) within the Tower Building shall be made without the prior written approval of the Hotel Owner.

(ii) Hotel Owner shall not unreasonably withhold, delay or condition its approval, but may condition its approval on the changes being compatible, consistent and harmonious with the improvements on the remainder of the Property, Tower 2 and the Hotel Space. The approval required in this subparagraph (b) shall apply to, without limitation, colors, materials, and interior (to the extent visible from the exterior or public areas of the Tower Building, or located in the public areas of the Tower Building) and exterior lighting. Any request for approval submitted to Hotel Owner shall be accompanied by four (4) sets of detailed plans for the proposed changes. The requesting Party shall promptly submit to Hotel Owner any additional information or materials reasonably requested by Hotel

Owner for the purpose of aiding in its review of the original submission. If Hotel Owner disapproves, it shall so advise in writing within 30 days after receipt of the complete submission, specifying the reasons for disapproval. Any resubmittal by the requesting Party shall follow the same procedure, which shall continue until approval has been granted. Hotel Owner shall not be responsible for reviewing, nor shall its approval be deemed approval of, any items from the standpoint of structural safety, soundness, workmanship, materials, usefulness, conformance with building or other codes or industry standards, or compliance with governmental requirements; the approval rights granted in this subparagraph (b) are solely for the benefit of Hotel Owner and neither the other Party, nor any employees, agents or representatives thereof, shall have any liability to anyone as a result of approvals granted pursuant to this subparagraph (b).

(iii) Changes by Hotel Owner. Subject to the provisions contained in this Agreement, Hotel Owner shall have the right at any time and from time to time, without the need for obtaining consent or approval from any other Party, to change, rearrange, alter, modify, build upon or otherwise reduce the easement areas created by this Agreement and located on its portion of the Property or the Hotel Space, as applicable. In the event any of same are accomplished with respect to the easement areas located on its portion of the Property or Hotel Space, same shall automatically release the easement area which is so changed, rearranged, altered, modified, built upon or otherwise reduced, from this Agreement. In addition to the foregoing, Hotel Owner specifically shall have the right, without the need for obtaining consent or approval from any other Party, to replace, alter or add to any existing buildings or structures located on its portion of the Property or Hotel Space or to build any new buildings or structures on its portion of the Property or Hotel Space as it may from time to time desire, regardless of whether or not the additions or replacements are constructed wholly or partly upon the easement or license areas created by this Agreement, subject to compliance with the provisions contained herein. If the foregoing requires relocation of any then existing utility or drainage facilities, or other components for which easements have been granted by this Agreement, Hotel Owner shall be responsible, at its cost, for relocating such utility or drainage facilities, or other components for which easements have been granted in this Agreement, and same shall be accomplished in a manner that minimizes disruption of (and, to the extent reasonably possible, avoids interruption of) service and accessibility for maintenance and in a manner so as to minimize inconvenience to and disruption of the owners and occupants of the remaining portions of the Property. Further, Hotel Owner may, with the approval of Tower Building Owner (which shall not be unreasonably withheld, delayed or conditioned) and at Hotel Owner's sole cost (except for a change in exterior color in connection with a regularly scheduled repainting of the Tower Building, which shall be at Tower Owner's sole cost; in this regard, Tower Building Owner shall, prior

to repainting the exterior of the Tower Building, notify Hotel Owner, and Hotel Owner shall have the right to request a change in the exterior color, which request shall not be unreasonably rejected by Tower Building Owner), change the exterior appearance of the Tower Building.

(c) Intentionally omitted.

(d) Weight Loads. Neither Party shall permit the weight load from any portion of its Property to exceed the load-bearing capacity of the applicable portion of the structure located on the Property.

(e) Odors. Neither Party shall permit any offensive odors originating from its portion of the Property to permeate the portion of the Property owned by the other Party; provided, however, that both Parties recognize that it is difficult to control odors within the Freight Docks and Compactor Space areas due to the nature of the use of those areas and, although reasonable steps to minimize odors from those areas will be taken, the provisions of this subparagraph shall be interpreted to give due consideration to the difficulty in controlling odors in these areas.

(f) Increased Insurance Costs. Neither Party shall use its portion of the Property in a manner that will increase the cost of insurance for the other Party unless the Party making such use reimburses the other Party for the increased insurance costs.

(g) Limitations on Use of Tower Building. The Tower Building shall be utilized solely for residential use, including full, part time or transient/hotel residential occupancy. No portion of the Tower Building shall be utilized for retail, industrial, warehouse or restaurant use (restaurant use shall not include room service to units within the Tower Building or an "honor" bar that provides beverages and snacks). The use of the Tower Building shall not be changed from that existing immediately following completion of the Initial Construction if such change in use would require under applicable law (without giving effect to any variances that may be obtainable or obtained) a greater amount of parking than is required for the Tower Building as of the date of completion of the Initial Construction. Tower Building Owner acknowledges being aware of a general high parking demand in the vicinity of the Property and the intent of the foregoing is to attempt to avoid adding to such high parking demand.

(h) Hazardous Materials. Each Party agrees that it will not generate, use, store or dispose of any hazardous materials or substances on any portion of the Property except in full compliance with all Legal Requirements and each Party shall indemnify and hold the other Party, its officers, directors, mortgagees, agents, employees and representatives harmless from and against all claims,

losses, damages, expenses and liabilities (including reasonable attorneys' fees at all tribunal levels and in connection with all proceedings, whether or not suit is instituted) arising from or in connection with the breach by the indemnifying Party of the foregoing agreement. Hazardous substances or materials for purposes of the foregoing shall mean any substances or materials that are from time to time designated as such by, or whose generation, use, storage or disposal is regulated pursuant to, any Legal Requirements. If either Party receives any notice of the release of a hazardous material or substances affecting the Property, it shall promptly notify the other Party, and each Party shall cooperate with all reasonable requests of the other Party in respect of remediation, at no cost to the Party being requested to cooperate except to the extent such Party is liable for indemnification as hereinabove provided.

(i) Government Compliance.

(A) From and after construction of the initial Permitted Improvements, no changes to any portion of the Entry/Garage Space, Tower Building or the Hotel Space will be made that increase government setback, parking, open space, floor to area ratio or similar requirements (the "Compliance Requirements") unless the increase is wholly absorbed by portions of the Entry/Garage Space, Tower Building or Hotel Space owned by the Party who is effecting the increase. Further, in the event of a casualty, taking by condemnation or deed in lieu thereof, demolition or similar event, to the extent any Compliance Requirements are higher at the time restoration is sought than those in effect at the time the improvements being restored were erected, and either upgrading of any Compliance Requirements in connection with restoration work (an "Upgrade") or downsizing of the restoration work (a "Downsize") is needed in order for the restoration work to conform with then current Compliance Requirements, the allocation between the Entry/Garage Space, Tower Building, Tower 2 and Hotel Space of Compliance Requirement items for purposes of determining the extent to which each Party must Upgrade or Downsize, as applicable, its restoration work shall be determined by utilizing the quantity of setback, parking, open space, floor area ratio, landscaped open space or similar items actually required with respect to each of the Entry/Garage Space, Tower Building, Tower 2 and the Hotel Space at the time of the initial construction of the Tower Building. The foregoing provisions are agreed to in recognition of the fact that the Property, Tower 2 and the Hotel Space were and will continue to be treated, in the aggregate, as a single project for purposes of governmental land use regulations and obtaining governmental approvals for construction and, without the foregoing provisions, any increase in the foregoing items applicable to a portion of the Entry/Garage Space, Tower Building, Tower 2 or Hotel Space that is owned by one Party could adversely impact the portions of the

Entry/Garage Space, Tower Building, Tower 2 or Hotel Space owned by another Party.

(B) The Parties acknowledge that the City of Miami Beach or other applicable governmental authorities may require the joinder by both Parties in applications for permits to perform work within the Property and/or the Hotel Space. Each Party designates the other as its agent and attorney-in-fact, which designation is irrevocable and coupled with an interest, to join in such permitting applications for the purpose of binding such other Party, where the purpose of such permitting is maintenance (without change) of existing improvements within the Property and/or the Hotel Space. As to permits required for any other purpose in respect of the Tower Building, Hotel Owner does not appoint Tower Building Owner as its agent or attorney-in-fact for purpose of joining in such applications, and Tower Building Owner shall submit the application to Hotel Owner for review, approval and joinder, which will not be unreasonably withheld, delayed or conditioned, provided the work for which the permit is being sought is in accordance with the terms of this Agreement. As to permits required for any other purpose in respect of the Hotel Space and/or the Entry/Garage Space, Tower Building Owner hereby designates Hotel Owner as its agent and attorney-in-fact, which designation is irrevocable and coupled with an interest, to join in any such permitting application, provided the work to be performed pursuant to such application is in accordance with the terms of this Agreement; provided, however, that no such joinder will be effected prior to completion of Initial Construction and, thereafter, prior to joining in any such permitting application as attorney-in-fact for Tower Building Owner, Hotel Owner shall submit the application to Tower Building Owner for review, approval and joinder, which will not be unreasonably withheld, delayed or conditioned, provided the work for which the permit is being sought is in accordance with the terms of this Agreement, but if approval or joinder is not provided by Tower Building Owner within 5 days after submission for any reason whatsoever, Hotel Owner may join in such permitting application as attorney-in-fact as aforestated (the City of Miami Beach shall be entitled to conclusively presume that Hotel Owner has complied with the foregoing proviso if Hotel Owner submits a permitting application signed by Hotel Owner as attorney-in-fact). Both Parties release the City of Miami Beach from any liability for processing applications for, or granting, permits at the request of one Party, without requiring joinder of the other Party. The City of Miami Beach may rely on the provisions of this subparagraph. The Parties further acknowledge being aware that, in connection with permitting pertaining to any portion of the Property and/or the Hotel Space, the Party applying for such permit may have to submit plans for the entire Property and/or the Hotel Space and, if this is required by applicable governmental authorities, each Party shall cooperate with the other, at no cost to the cooperating Party, in accomplishing this in a manner that minimizes delay in the application process.

(C) In order to facilitate enforcement of Legal Requirements pertaining to the Property by applicable governmental authorities (the "Authorities"), which include the City of Miami Beach, each Party agrees that the Authorities are authorized to issue violation notices to the Tower Building Owner with respect to any violations of Legal Requirements that pertain to the Tower Building (and to enforce same against the Tower Building) and to issue violation notices to the Hotel Owner with respect to any violations of Legal Requirements that pertain to the Hotel Space or the Entry/Garage Space (and to enforce same against the Hotel Space and/or the Entry/Garage Space). If in doubt, the Authorities are authorized to forward notices of violations of Legal Requirements to Hotel Owner and to enforce same against the Hotel Space, the Entry/Garage Space and Hotel Owner, subject to the following provisions. Anything contained in this subparagraph to the contrary notwithstanding, (i) the provisions contained elsewhere in this Agreement regarding allocation of responsibility for compliance with Legal Requirements shall govern as between the Parties and, as between the Parties, the provisions of this subparagraph shall have no effect whatsoever on their respective rights and liabilities as set forth elsewhere in this Agreement; (ii) each Party shall, within five (5) days of receipt, furnish to the other Party a copy of any notices received from the Authorities pertaining to any violation of Legal Requirements, compliance with respect to which is or may be the responsibility of the other Party; and (iii) in the event the Authorities furnish a notice of violation of Legal Requirements in respect of the Property to one Party and the other Party is responsible for remedying the matter giving rise to the violation, Hotel Owner may deliver to the Authorities an affidavit so stating (which affidavit Tower Building Owner shall also sign promptly upon request of Hotel Owner or, at Hotel Owner's sole option (but only from and after completion of Initial Construction), and without the need for Hotel Owner to first request Tower Building Owner to sign such affidavit, Hotel Owner is designated as the agent and attorney-in-fact for Tower Building Owner, which designation is irrevocable and coupled with an interest, to sign such affidavit on behalf of Tower Building Owner and thereby bind Tower Building Owner and the Tower Building) and the Authorities are authorized, upon receipt of such affidavit, to notice the other Party for the violation, implement enforcement proceedings for such violation against the other Party's portion of the Property and release/discontinue enforcement proceedings in respect of such violation against the Party originally cited. The Authorities are authorized to rely solely on the affidavit of Hotel Owner and Tower Building Owner (signed by Tower Building Owner either in its own name or by Hotel Owner as agent and attorney-in-fact) in effecting the foregoing, regardless of any objections received from Tower Building Owner. Tower Building Owner waives the right to assert against the City of Miami Beach that it is not responsible for any violation against the Tower Building or Tower Building Owner that is imposed as a result of the foregoing process, and Tower Building Owner shall cure or defend against any such violations, subject to its

rights to recover against Hotel Owner (but not the City of Miami Beach) under appropriate circumstances as provided elsewhere in this Agreement, and Tower Building Owner shall indemnify, defend and hold the City of Miami Beach harmless from and against all costs and expenses, including, without limitation, reasonable attorneys' fees, arising from any attempts by Tower Building Owner to avoid the effects of the foregoing provisions. Each Party releases the Authorities and its employees from all liabilities arising from their compliance with the provisions of this subparagraph.

6. Maintenance.

(a) Generally. Subject to the last two sentences of this subparagraph (a) and the provisions of subparagraph 4(g), each Party agrees to operate and fully maintain, repair and, when necessary, replace, at its cost and expense, all portions of the Property and Hotel Space owned by it, as well as all areas that it has agreed to operate, maintain, repair and replace elsewhere in this Agreement and all items, equipment, facilities and other items with respect to which it has exclusive rights (regardless of who actually owns the portion of the Property on which such items that are the subject matter of exclusive rights are located, which owner shall have no obligations with respect to such items), so that same are at all times in first class order, condition and repair, consistent with first class hotel/condo-hotel facilities of similar stature to that of the Property in the South Florida area. The foregoing obligation to operate, maintain, repair and, when necessary, replace, shall include, without limitation: (i) keeping all portions of the Property and Hotel Space in a clean, uncluttered, orderly, watertight and sanitary condition; (ii) removing, to the extent practicable, surface waters; (iii) keeping all marking and directional signs, if any, on the Property and Hotel Space clear, distinct and legible; (iv) maintaining, mowing, weeding, trimming and watering all landscaped areas; (v) maintaining and operating exterior lighting at reasonable levels during hours of darkness; and (vi) painting and otherwise maintaining the exterior surfaces of the buildings on the Property and Hotel Space. In supplementation of the foregoing, fire alarm sensors in the Entry/Garage Space shall be the responsibility of Hotel Owner, subject to contribution in accordance with Subparagraph 6(b) below, fire alarm sensors in the Tower Building shall be the responsibility of Tower Building Owner at its sole cost and fire alarm sensors in the Hotel Space shall be the responsibility of Hotel Owner at its sole cost and without contribution in accordance with Subparagraph 6(b) below. Notwithstanding the foregoing obligations to operate, maintain, repair and replace, if either Party, or those claiming under it, abuses, misuses or fails to operate, maintain, repair or replace in the manner provided in this Agreement any item for which it is responsible under this Agreement or otherwise creates a situation in any portion of the Property or Hotel Space with respect to which non-exclusive easements or licenses have been granted by this Agreement

such that said areas require operation, maintenance, repair or replacement in excess of what would be required by normal use of said areas for their intended purposes (and assuming performance by the other Party of its obligations under this Agreement), the Party causing the excess use shall be responsible for the excess costs of operating, maintaining, repairing and replacing said areas. Each Party shall maintain and promptly upon request, from time to time, make available to the other Party at the Property or Hotel Space complete maintenance records for all portions of the Property with respect to which easement rights exist under this Agreement. As to any items (such as exterior painting) that require coordination or cooperation as to timing, materials, payment or the like, the Parties shall be reasonable in so cooperating and coordinating. It is anticipated that some or all "common areas" of the Tower Building, such as (but not limited to) hallways, Elevators, stairwells, common lounges, pool and deck areas and common conference of kitchen facilities will be conveyed to Hotel Owner's designated affiliate at the time of conveyance (the "Designated Affiliate") and will be under the Designated Affiliate's exclusive operational control (and maintained, repaired insured and replaced by the Designated Affiliate). Thus, notwithstanding the foregoing provisions, if and to the extent any costs of operating, maintaining, repairing, insuring or replacing any such "common areas" (including, without limitation, paying taxes and/or any public or private assessments) are paid by the Designated Affiliate, they will nonetheless be the sole obligation of Tower Building Owner (other than the owner of such "common areas") and the procedures and security for contribution therefor/reimbursement thereof to the Designated Affiliate will be set forth in the declaration of condominium filed for the Tower Building or, in the absence of such a filing, as set forth in subparagraph (b) below.

(b) Tower Building Contribution to Operating Expenses.

Although Hotel Owner shall be solely responsible for operating, maintaining, repairing, insuring (and paying taxes on, as more particularly provided for in paragraph 7 below) and, when necessary, replacing (including painting, illuminating, and cleaning, and labor for same) the Entry/Garage Space as provided elsewhere in this Agreement, Tower Building Owner shall pay (to Hotel Owner) its share of the costs incurred by the Hotel Owner (as budgeted, as hereinbelow provided, with an annual year-end reconciliation, or within 30 days of invoicing in the case of non-budgeted emergency work) in operating, maintaining, repairing, insuring (and paying taxes on, as more particularly provided for in paragraph 7 below) and replacing the Entry/Garage Space. The Tower Building Owner's share shall be 100% (based on the fact that all parking in the Entry Garage Space is required, for zoning purposes, to service solely the Tower Building). In addition to the foregoing, and to compensate Hotel Owner for use of the public areas of the Hotel Space for which the right to use is granted elsewhere in this Agreement as well as for access to the switchboard for the Hotel Space for internal calls (such as to

reception, room service and the like), but not for the actual phone set(s) or outside (local or long distance) calls for which additional charges may be imposed), Tower Building Owner shall pay to Hotel Owner a fixed monthly "Access Fee" equal to \$60.00 per month for each studio unit, \$90.00 per month for each 1 bedroom unit and \$270.00 for the Tower Suite, which Access Fee shall increase 5% each year (on each January 1), commencing on January 1 of the year immediately following the recording of the declaration of condominium contemplated to be recorded for the Tower Building (but no later than January 1, 2008). Tower Building Owner shall pay the budgeted payment, the amount owed as reflected by the annual year-end reconciliation, the amount invoiced for emergency work and the Access Fee within the time frames provided for herein, in each case whether or not it disputes such amount, although such payment may be made under protest. If Tower Building Owner fails to pay the Access Fee or any amount payable on account of operating, maintaining, repairing, insuring (and paying taxes on, as more particularly provided for in paragraph 7 below) or replacing the Entry/Garage Space when due, said amount shall accrue interest from the date due until paid at the Default Rate, Hotel Owner shall have a lien against the Tower Building for such amount, together with interest and Collection Costs (as hereinafter defined), and such lien shall relate back to and have priority as of the date of recording of this Agreement (except that, as to any First Institutional Mortgagee, as defined in subsection 12(h) below, who holds a first mortgage encumbering all or a portion of the Tower Building, but no one else, such lien shall have priority as of the date of recording in the public records of Miami-Dade County, Florida, of a claim of lien by Hotel Owner or its designated affiliate which, among other things, identifies the liened property and the fact that sums are owed pursuant to this Agreement) and may be foreclosed in the same manner as a mortgage may be foreclosed. Hotel Owner shall establish an annual budget for operating, maintaining, repairing, insuring (and paying taxes on, as more particularly provided for in paragraph 7 below) and replacing the Entry/Garage Space, which budget shall be furnished to Tower Building Owner (at least 90 days before the end of each calendar year, or the budget for the prior year shall govern for purposes of the monthly budgeted payments to be made for the next calendar year, subject to year-end reconciliation to reflect actual costs), and Tower Building Owner shall pay monthly in advance on the first day of each month one-twelfth (1/12) of its aforesaid share of the amount reflected on such budget, together with the amount of the Access Fee; Hotel Owner shall provide Tower Building Owner with an annual reconciliation, including supporting documentation, and the amount of any adjustment resulting from such reconciliation shall be paid by the applicable Party to the other within 30 days after the annual reconciliation is furnished to Tower Building Owner. Hotel Owner agrees that the costs incurred by it for operating, maintaining, repairing and replacing the Entry/Garage Space shall be consistent with the costs incurred by similar facilities in the vicinity of the Property, taking into consideration the nature of the materials

utilized in the construction of the Property. In order to allow Tower Building Owner to determine the adequacy of the charges made by Hotel Owner hereunder, Hotel Owner agrees to make its books and records pertaining to such charges available for inspection at reasonable times and on reasonable advance notice for review by Tower Building Owner, no more than twice per year, upon notice furnished to Hotel Owner within 180 days after receipt by Tower Building Owner of the annual reconciliation for the applicable year, and by an independent certified public accountant reasonably acceptable to Hotel Owner. In the event Tower Building Owner is successful in disputing any amount paid by it under protest, Tower Building Owner shall be entitled to reimbursement of such amount, together with interest thereon from the date paid until the date reimbursed at the Default Rate.

(c) Common Walls, Floors and Ceilings. Anything in this Agreement to the contrary notwithstanding, the dividing walls, floors and ceilings separating the Entry/Garage Space and the Tower Building shall be deemed to be party walls, floors and ceilings and each Party shall be responsible for one-half of the costs of maintenance, repair and replacement of such party walls, floors and ceilings; provided, however, that any dividing wall, floor or ceiling separating the Tower Building and the Entry/Garage Space that consists of a double wall, floor or ceiling shall not be deemed to be a party wall, floor and ceiling and the wall, floor or ceiling closest to the Tower Building shall be owned, maintained, repaired and replaced solely by the Tower Building Owner and the wall, floor or ceiling closest to the Entry/Garage Space shall be owned, maintained, repaired and replaced solely by the Hotel Owner and, further provided, that each Party shall take all steps required to assure that the fire separation capabilities of such party walls, floors and ceilings are not breached or otherwise adversely impacted by it or anyone claiming by, through or under it. The Parties shall cooperate and coordinate with each other with respect of the maintenance, repair and replacement of all party walls, floors and ceilings.

(d) Sump Pumps and Discharge/Deep Wells. Hotel Owner shall be solely responsible for the operation, maintenance, repair, insuring (and paying taxes on, as more particularly provided for in paragraph 7 below) and replacement of all sump pumps and discharge/deep wells serving the Property, the costs of which shall be included in the costs of operating, maintaining, repairing, insuring (and paying taxes on, as more particularly provided for in paragraph 7 below) and replacing other components of the Entry/Garage Space.

(e) Remedies. If either Party breaches its obligation to operate, maintain, repair and, when necessary, replace as set forth in this Agreement, the other Party may send written notice to such breaching Party and, if such obligations are not performed by the breaching Party within 15 days from receipt of such notice (if not reasonably capable of being fully performed within 15 days, such time

frame shall be extended for such reasonable additional time as may be needed to perform so long as performance commences within such 15 day period and proceeds continuously, in good faith and with due diligence until completion), then the Party giving notice shall have the right (without limiting any other rights that may be available) to perform such obligations and bill the breaching Party for the costs of such performance. If the breaching Party shall not pay such bill within 15 days of receipt, then interest shall accrue on the unpaid amount from the time it was expended until paid at the Default Rate, and, as to amounts associated with the Property only, the amount owed, together with interest and Collection Costs, shall be a lien on the Property of the breaching Party, which lien shall relate back to, and take priority as of, the date of recording of this Agreement (except that, as to any First Institutional Mortgagee who holds a first mortgage encumbering all or a portion of the Tower Building, but no one else, such lien shall have priority as of the date of recording in the public records of Miami-Dade County, Florida, of a claim of lien by Hotel Owner or its designated affiliate which, among other things, identifies the lien property and the fact that sums are owed pursuant to this Agreement) and may be foreclosed in the same manner as a mortgage may be foreclosed. Notwithstanding the foregoing, in the event of an emergency, the notice and opportunity to cure provided above shall not be required but, rather, only such notice as may be reasonable under the circumstances shall be required (including telephonic notice or no notice at all); the Party relying upon the provisions of this sentence shall only perform such work as is reasonably necessary to stabilize the situation and eliminate the emergency situation, and all other or additional work shall require notice and opportunity to cure as provided above. The provisions of this subparagraph shall specifically, without limitation, be applicable to the remedying of violations of Legal Requirements by the respective Parties as elsewhere provided in this Agreement.

(f) Indemnity. Each Party hereby indemnifies and saves harmless the other Party and those claiming by, through or under it from any and all liability, damage, expense, causes of action, suits, claims or judgments arising from the portion of the Property that is owned by it, including, without limitation, arising out of the use of the service mark "Fontainebleau", except to the extent caused by the act or negligence of such other Party or those claiming by, through or under it.

7. Taxes.

(a) Hotel Owner shall pay, with the maximum allowable discount, all taxes and assessments, real and personal, whether general or special, levied against the Entry/Garage Space and its components; provided, however, that Tower Building Owner shall deliver to Hotel Owner, at least five (5) business days prior to the end of the month during which Hotel Owner may pay the taxes for the

Entry/Garage Space with the maximum allowable discount (currently November of each year), a check payable to the taxing authority in an amount equal to 100% of the amount due and Hotel Owner shall deliver said check and its check payable to the taxing authority for the remaining -0-% of the taxes payable on the Entry/Garage Space prior to the end of said month (Tower Building Owner's percentage was calculated using, as the numerator, the number of parking spaces in the Entry/Garage Space that are required by applicable zoning regulations for the Tower Building and, as the denominator, the total number of parking spaces in the Entry/Garage Space; Hotel Owner's percentage was calculated by taking 100% and subtracting Tower Building Owner's percentage) and, further provided, that Hotel Owner may, at its sole option, include estimated taxes in the annual budget contemplated by subparagraph 6(b), in which event the Tower Building Owner shall pay monthly estimated payments on account of taxes, with an annual reconciliation as contemplated by such subparagraph 6(b).

(b) The foregoing shall not preclude Hotel Owner from contesting taxes, so long as appropriate steps are taken to prevent a sale of the Entry/Garage Space on account of non-payment thereof. Hotel Owner, in the first instance, shall pay the full costs for any such appeal; provided, however, that the costs of such appeal shall be deducted from any savings realized as a result of the tax contest prior to prorata distribution to the Parties of the tax savings realized from the contest and any excess costs of appeal shall be shared by the Parties in accordance with the percentage sharing of taxes as specified in subparagraph (a).

(c) The foregoing shall not preclude payment in installments, to the extent available, and installment payments shall be elected unless both Parties agree to the contrary.

(d) Each Party agrees to cooperate with all reasonable requests of the other in an attempt to have the Tower Building, the Hotel Space and the Entry/Garage Space separately assessed for tax purposes. If, for whatever reason, separate assessments are not possible, each Party shall cooperate and coordinate with the other in equitably allocating (provided, however, that the allocation suggested by Hotel Owner (after consultation with and the reasonable approval of the Designated Affiliate) shall be utilized initially for purposes of paying the taxes, but Tower Building Owner shall have the right to protest such allocation if, and only if, manifestly unfair and, if successful, Tower Building Owner shall be entitled to reimbursement, together with interest thereon from the date paid until the date reimbursed at the Default Rate) and jointly paying the taxes assessed against the Property and Hotel Space, with the maximum allowable discount.

(e) If either Party breaches its payment obligations under this paragraph, the other Party shall have the right, but not the

obligation, at any time thereafter, to remedy the breach by paying the applicable amount to the applicable authority, and any such payment shall accrue interest at the Default Rate from the date paid until the date repaid and, as to the amounts allocable to the Entry/Garage Space only, the amount so paid, together with interest thereon and Collection Costs, shall be a lien on the portion of the Property owned by the breaching Party, which lien shall relate back to and have priority as of the date of recording of this Agreement (except that, as to any First Institutional Mortgagee who holds a first mortgage encumbering all or a portion of the Tower Building, but no one else, such lien shall have priority as of the date of recording in the public records of Miami-Dade County, Florida, of a claim of lien by Hotel Owner or its designated affiliate which, among other things, identifies the liened property and the fact that sums are owed pursuant to this Agreement) and may be foreclosed in the same manner as a mortgage may be foreclosed.

8. Insurance and Restoration.

(a) Types of Insurance. Each Party shall maintain at all times while this Agreement remains in effect, at its cost, the following:

(i) "special form" insurance on the portion of the Property owned by it or with respect to which it has exclusive easement rights or exclusive operation, maintenance, repair and/or replacement obligations (even though not owned by it) against all risks of physical loss or damage (including windstorm) that are covered by such policy of property insurance in an amount not less than 100% of full replacement cost (excluding excavation, foundations and footings), with an agreed amount endorsement if coverage is by way of a blanket policy. Said policy shall include demolition and debris removal coverage;

(ii) commercial general liability insurance (including blanket contractual liability, personal injury and advertising injury, and, if applicable, liquor liability) covering the portion of the Property owned by it and all items with respect to which it has exclusive rights or exclusive operation, maintenance, repair and/or replacement obligations in amounts of at least \$1,000,000 per occurrence in the aggregate, \$1,000,000 products liability and completed operations aggregate and \$10,000,000 excess umbrella coverage;

(iii) at all times during which construction is being performed in connection with the portion of the Property owned by it or items with respect to which it has exclusive rights or exclusive operation, maintenance, repair and/or replacement obligations, builder's risk insurance with limits of coverage not less than that specified in subparagraph (i) above, independent contractor's

insurance and blanket contractual liability insurance with limits of coverage not less than that specified in subparagraph (ii) above. In addition, owner's and contractor's protective insurance with a minimum coverage of \$1,000,000 shall be required unless all contractors performing work in connection with such construction maintain no less than \$1,000,000 of general liability insurance, naming the Parties and their mortgagees as additional insureds and satisfying the standards set forth elsewhere in this Agreement for insurance to be maintained by the Parties;

(iv) worker's compensation insurance at legally required levels and employer's liability insurance in an amount not less than \$1,000,000 for the benefit of all employees entering upon the portion of the Property owned by it or items with respect to which it has exclusive rights or exclusive operation, maintenance, repair and/or replacement obligations, as a result of or in connection with their employment by the Party maintaining such coverage or any agent, representative, licensee or contractor of such Party (or where such Party is otherwise legally liable);

(v) insurance against loss or damage by boiler or compressor or internal explosion of a boiler or compressor if such items shall be located on or at the portion of the Property owned by it or are items with respect to which it has exclusive rights or exclusive operation, maintenance, repair and/or replacement obligations with limits of coverage not less than that specified in subparagraph (i) above; and

(vi) such other insurance including, without limitation, flood, plate glass and malicious mischief insurance, and in such amounts, and such increases to the foregoing coverages, as are customarily maintained with respect to facilities similar in construction, location and use to the facilities located on the Property.

(b) Standards for Insurance. The policies provided for in subparagraph 8(a) may contain a reasonable deductible, not to exceed \$10,000 for property perils (excluding windstorm), 2% of value for windstorm peril, \$100,000 for flood and earthquake perils and \$10,000 for general liability coverage, unless both Parties approve of higher or different deductibles in their reasonable discretion. The policies maintained by each Party shall name the other Party and any mortgagees of the other Party of which notice has been provided as additional named insureds (in the case of casualty and liability policies) and copies of the policies and certificates of insurance shall be provided to all named insureds promptly upon request. The insurance companies providing insurance shall have a Best's rating of not less than A(-)VII (or its equivalent) at the time each policy is acquired or renewed. Each policy of casualty and liability insurance shall contain a waiver of subrogation rights against the other Party, its

mortgagee(s) and tenant(s), and their respective agents, employees and representatives; and each Party, for itself and for its mortgagee(s) and tenant(s) and their respective agents, employees and representatives, waives any liability that the other Party or its mortgagee(s) or tenant(s) or their respective agents, employees or representatives might have which was covered or should have been covered by the insurance provided for in this subparagraph.

(c) Remedies. In the event either Party fails to maintain the insurance required hereunder, the other Party may, but shall not be obligated to, obtain such insurance coverage for the defaulting Party and the defaulting Party shall, within 15 days of demand therefor, reimburse the other for the cost thereof. If the defaulting Party fails to do so, interest shall accrue on the amount owed at the Default Rate from the date paid until the date reimbursed, and such amount together with interest and Collection Costs shall be a lien on the portion of the Property owned by the defaulting Party, such lien shall relate back to and take priority as of the date of recording of this Agreement (except that, as to any First Institutional Mortgagee who holds a first mortgage encumbering all or a portion of the Tower Building, but no one else, such lien shall have priority as of the date of recording in the public records of Miami-Dade County, Florida, of a claim of lien by Hotel Owner or its designated affiliate which, among other things, identifies the liened property and the fact that sums are owed pursuant to this Agreement) and such lien may be foreclosed in the same manner as a mortgage may be foreclosed.

(d) Casualty. In the event any portion of the Property, or any items therein, is damaged or destroyed by reason of casualty, the Party who owns the damaged or destroyed portion of the Property, or the items therein, shall, in good faith and with due diligence, settle the loss and restore the damaged or destroyed portion to at least the following extent: (i) the portions of the Tower Building that are visible from the exterior (including the exterior shell) shall be restored to substantially the condition they were in prior to the damage or destruction (which includes a fake facade, if so desired) and (ii) all easement areas benefiting the other Party (including, without limitation, party walls, floors and ceilings) shall be restored to substantially the condition they were in prior to the damage or destruction and (iii) all areas that must be restored in order for all other portions of the Property to be watertight, secure and not a hazardous condition shall be restored to such extent; and (iv) to the extent parking spaces within the Property are reduced below the quantity allocated to the Tower Building herein for zoning purposes, Hotel Owner shall restore parking spaces, if necessary, so that, after the restoration, there are located within the Property at least a number of parking spaces equal to those allocated to the Tower Building for zoning purposes under this Agreement (and Tower Building Owner shall be entitled to claim entitlement to such parking spaces for zoning purposes in connection with the restoration); provided,

however, in any event, the damage or destruction can be restored to such different condition (subject to the provisions of this Agreement, however, respecting relocation of easements and other matters) as the Hotel Owner may determine (in the case of the Hotel Space), or approve (as to the Tower Building), which approval shall not be unreasonably withheld or delayed, but the provisions of subparagraph 5(b) shall govern any changes; and, further provided, that if restoration to substantially the condition they were in prior to the damage or destruction is not then permitted by applicable Legal Requirements, restoration shall be to as nearly the condition they were in prior to the damage or destruction as may then be permitted by applicable Legal Requirements. The Parties shall cooperate with each other, and shall exert reasonable efforts to cause their insurance companies to work together, with a view toward restoring damage that affects portions of the Property with respect to which there is joint use by virtue of the easements granted by this Agreement. The insurance proceeds payable on account of damage or destruction to the Property shall first be applied toward the restoration obligations set forth herein, and the balance shall be disbursed as directed by the Party sustaining the loss. In the event either Party breaches its restoration obligations under this subparagraph or under paragraph 9 regarding restoration after condemnation, the other Party, after 30 days prior written notice, shall be entitled to perform such restoration at the breaching Party's cost, and the breaching Party shall reimburse the amounts so incurred, together with interest thereon from the date paid until the date reimbursed at the Default Rate, promptly upon demand; the costs so incurred, together with interest and Collection Costs, shall be a lien on the portion of the Property owned by the breaching Party, which lien shall relate back to and take priority as of the date of recording of this Agreement (except that, as to any First Institutional Mortgagee who holds a first mortgage encumbering all or a portion of the Tower Building, but no one else, such lien shall have priority as of the date of recording in the public records of Miami-Dade County, Florida, of a claim of lien by Hotel Owner or its designated affiliate which, among other things, identifies the liened property and the fact that sums are owed pursuant to this Agreement) and may be foreclosed in the same manner as mortgages may be foreclosed.

9. Condemnation. In the event any portion of the Property, or any item therein, is condemned or taken through eminent domain or by deed in lieu thereof, the owner of the portion of the Property, or any item therein, so taken shall be entitled to the full award therefor as if this Agreement were not in existence and the other owner(s) shall not be entitled to share in any portion of the award as a result of the existence of this Agreement; provided, however, that the foregoing shall not prevent an award to any other owner(s) for the diminution in value of the Property of the other owner(s), provided same does not reduce the award payable to the owner whose property was condemned or taken. In the event of a taking, the provisions of subparagraph 8(d)

of this Agreement shall apply and the portion of the Property that is not taken shall be restored as required therein and the condemnation proceeds available as a result of the condemnation shall be disbursed as set forth therein for insurance proceeds.

10. Parking.

(a) Tower Building Owner acknowledges being aware that the Tower Building portion of the Property contains no parking. For purposes of complying with zoning and other governmental requirements only (all parking revenue shall belong to Hotel Owner and all parking shall be under the control of Hotel Owner), Hotel Owner hereby designates 312 parking spaces (based on 1.5 spaces for each of the 49-1 bedroom units, 1.0 parking spaces for each of the 236 studio units, and 2 parking spaces for the 1 Tower Suite, as required under the City of Miami Beach Code as in effect on the date of recording of this Agreement) located within the Entry/Garage Space (the location of which shall be determined by, and may be changed from time to time by, Hotel Owner in its reasonable discretion) for the benefit of the Tower Building (which shall be equitably reduced if and to the extent any parking spaces are hereafter taken through condemnation or deed in lieu thereof). The balance of the parking spaces in the Entry/Garage Space and all parking spaces within the Hotel Space are for the sole use and benefit of the Hotel Owner or others to whom it has granted such rights. The number of parking spaces so designated are the Tower Building's and Hotel Space's equitable portions of the number of parking spaces required under governmental requirements existing as of the date of recording of this Agreement, but this shall not be deemed to provide or confer legal non-conforming status to either the Tower Building or the Hotel Space with respect to parking in the event of casualty, condemnation, demolition or any similar event.

(b) Hotel Owner shall provide Tower Building Owner with valet parking services for Tower Building owners, residents and guests, with pickup service at a station within the Entry/Garage Space, to be manned by an agent of, or designee or independent contractor engaged by, Hotel Owner. The costs of operating, maintaining, repairing, insuring (and paying taxes on, as provided in paragraph 7) and replacing the valet parking service (including, without limitation, labor costs thereof) and facilities needed to operate the valet parking service (such as check in desk) shall be included in the costs specified in subparagraph 6(b) above. In addition to the payments contemplated by subparagraph 6(b) above, Hotel Owner may charge owners, residents and guests of the Tower Building that use the Entry/Garage Space a valet parking use charge at the rate for valet parking which is consistent with that imposed by Hotel Owner for valet parking for the Hotel Space. All valet parking use charges shall be collected directly from Tower Building residents or guests, and Tower Building Owner shall not be liable therefor. Notwithstanding the foregoing, from and after the date that the Tower

Building is subjected to the condominium form of ownership, if ever, owners of individual units in the Tower Building (and their family members or personal friends while actually occupying such units with the owners permission, but no one else) shall be entitled, while in actual occupancy of their individual units only, to have one car [two cars in the case of the Tower Suite] at any given time per unit valet parked with no valet parking use charge. Storage of vehicles when the owner, such family members or personal friends are not actually occupying the unit shall not be permitted except in Hotel Owner's sole discretion and subject to such charge as Hotel Owner in its sole discretion may impose. Employee parking for the Tower Building will be handled in the same way as employee parking for the Hotel Space is handled (ex. if the Hotel Space requires employees to park off site, the Tower Building employees will have to park off site). Valet parking service shall be provided as aforesated 24 hours per day, 365 days per year, on a first come, first served basis, consistent with what is provided in respect of the Hotel Space. Tower Building Owner shall receive no portion of the parking income collected from Tower Building residents or guests.

(c) Tower Building Owner shall abide by such reasonable non-discriminatory and, to the extent applicable, uniformly enforced rules and regulations as may be promulgated from time to time by Hotel Owner for use of parking spaces within the Property. Hotel Owner shall not be responsible for any loss or damage to any car, its occupant(s) or its contents by fire, theft, trespassing, vandalism, negligence or willful misconduct of third parties, or any other causes.

(d) Tower Building Owner hereby irrevocably and unconditionally assigns to Hotel Owner all rights that Tower Building Owner might otherwise have to participate in any governmental parking pool that might from time to time exist for the benefit of the Property and/or other lands. Tower Building Owner agrees, promptly upon request, to execute or join in the execution of any document reasonably requested by Hotel Owner to effect the foregoing, at no cost or liability to Tower Building Owner. Similarly, Tower Building Owner agrees, promptly upon request, to execute or join in the execution of any documentation reasonably requested by Hotel Owner pertaining to the Property, at no cost or liability to Tower Building Owner, provided such documentation does not adversely affect the Tower Building or its operations. The foregoing is agreed to in recognition of the fact that the Property will, for many purposes, be viewed as a single facility notwithstanding the fact that portions thereof are owned by separate Parties.

11. "Fontainebleau" Trade Name. Tower Building Owner acknowledges being advised of Hotel Owner's proprietary interest in the trade name "Fontainebleau" and will not dispute same. Tower Building Owner shall, at the request of Hotel Owner, utilize the name

"Fontainebleau" in the name of the Tower Building (either as a part of the name or as a locational reference that follows the name). In the event Tower Building Owner is required to utilize the name "Fontainebleau" as hereinabove provided, or elects to utilize such name (which it shall be entitled to do, subject to Hotel Owner's reasonable approval) Tower Building Owner shall, prior to such use, submit each item that so utilizes such name to Hotel Owner for Hotel Owner's approval of the manner of use of such name. Hotel Owner agrees to promptly approve or disapprove, with reasons, the use of such name in each such item submitted for approval. Tower Building Owner further agrees to comply with any other requirements that Hotel Owner may reasonably impose from time to time in order to protect its rights with respect to the "Fontainebleau" trade name.

12. Miscellaneous.

(a) Specific Performance. Anything to the contrary contained in this Agreement notwithstanding, in the event of a violation or breach of any of the provisions contained in paragraphs 1, 2, 3, 4, 5 and 11 and in subparagraphs 10(d) and 12(h)(v) of this Agreement, specific performance and/or injunctive relief shall specifically be available, it being agreed that damages would, at best, be difficult to ascertain and would be an inadequate remedy in any event. The foregoing shall not, however, preclude specific performance and/or injunctive relief in the event of a violation or breach of any other provisions of this Agreement, or constitute an acknowledgment that damages in the event of a violation or breach of any other provisions of this Agreement would be readily ascertainable or an adequate remedy.

(b) Prevailing Party Attorneys' Fees; WAIVER OF JURY TRIAL. The prevailing Party in any action in connection with this Agreement (whether in tort, contract or otherwise) shall be entitled to the award of court costs and a reasonable attorneys' and paralegals' fees at all tribunal levels and in connection with all proceedings, whether or not suit is instituted. The Parties, each being represented by counsel, knowingly, intentionally and voluntarily WAIVE TRIAL BY JURY (for themselves, their successors and assigns) in all actions or proceedings pertaining to the subject matter of this Agreement.

(c) Estoppel Certificates. Each owner from time to time of the Hotel Space or the Property, or any portion thereof, as well as the Association, as hereinafter defined, agrees, promptly upon request, to furnish from time to time to any other such owner in writing such truthful estoppel information and/or one or more confirmatory easements (confirmatory of the general easements granted hereby) as may be reasonably requested.

(d) No Public Dedication. Nothing contained herein shall be construed as a dedication of the easements granted herein to the general public.

(e) Covenant Running with Land; Modifications. This Agreement shall be a covenant running with the land and shall be binding upon and inure to the benefit of the owners from time to time of every portion of the Property and Hotel Space, their successors, assigns, employees, agents, customers, tenants, guests, licenses, invitees and mortgagees. Notwithstanding the foregoing, this Agreement may be abrogated, modified, terminated, rescinded or amended in whole or in part by an instrument executed by the then owners of the Entry/Garage Space and the Hotel Space, joined by their respective mortgagees (if any) and the Association, joined by any mortgagee whose mortgage encumbered the entire Tower Building prior to the recording of the declaration of condominium for the Tower Building, while said mortgage remains outstanding (or, prior to recording of a declaration of condominium for the Tower Building, the Tower Building Owner, joined by its mortgagee, if any). The joinder of any other owners of the Tower Building, or tenants, guests, licensees or invitees of any such owner (or anyone else, including, without limitation, the City of Miami Beach) shall specifically not be required in connection with any of the foregoing. Once the Designated Affiliate is selected, its successors and assigns shall succeed to the rights of such Designated Affiliate.

(f) Notices. Any notices required to be given hereunder shall be given by certified mail, return receipt requested, by hand delivery, by facsimile machine or by Federal Express or similar overnight courier service, postage prepaid, to the address specified in the introductory paragraph of this Agreement. Except as and to the extent expressly provided for below with respect to notices of change of address, notices that are given in the manner aforesaid shall be effective (regardless of whether or not they are actually received) upon mailing or depositing with Federal Express or similar overnight courier service, if mailed or deposited with Federal Express or similar overnight courier service, upon receipt of a transmission confirmation if sent by facsimile machine or upon receipt if hand delivered. Any Party hereto may change its address for notice by notifying the other Parties hereto in the manner provided for above; provided, however, that notices of change of address shall not be effective unless and until they are actually received, delivery is refused or they are returned because the address to which they were sent is no longer a current address and the Party sending such notice was not properly furnished a notification of change of address. Copies of any notices required to be given to another Party shall also be given to the holder of any mortgage encumbering the portion of the Property (specifically excluding any mortgagees of any portion of the Tower Building from and after the recording of a declaration of condominium in respect of the Tower Building, which mortgagees shall

not be entitled to notice; provided however, that any mortgagee whose mortgage encumbered the entire Tower Building prior to the recording of the declaration of condominium for the Tower Building shall be entitled to notice, while said mortgage remains outstanding) owned by such Party if the holder of any such mortgage has notified (in the manner provided for above for giving notice of change of address) the Party giving notice of such holder's address and requested that notices be furnished to such holder. Notice given by the attorney for any Party shall be as effective as if given by that Party.

(g) Governing Law; Invalidity; Liability After Sale; Counterparts. This Agreement shall be governed by the laws of the State of Florida. If any portion of this Agreement shall be or become illegal or unenforceable for any reason, the remaining portions shall remain in full force and effect and shall be enforceable to the fullest extent permitted by law. Upon sale of any portion of the Property, the transferor thereof shall be relieved of personal liability hereunder related to the time period subsequent to such transfer with respect to the portion so transferred. This instrument may be executed in counterparts, each of which shall be deemed an original but all of which shall constitute one and the same document.

(h) Certain Defined Terms; Construction.

(i) Whenever used in this Agreement, the term "Default Rate" shall mean a rate per annum equal to two percent (2%) above the prime rate from time to time published in the Wall Street Journal or its successor, or if it has no successor, a newspaper or other publication of similar stature. Whenever used in this Agreement, the term "Collection Costs" shall include all costs and expenses reasonably incurred in enforcing the applicable obligation(s) under this Agreement, including, without limitation, reasonable attorneys' and paralegals' fees at all tribunal levels, in connection with all proceedings, and whether or not suit is instituted.

(ii) Whenever used in this Agreement, the term "Initial Construction" shall mean construction of the new garage and approximately 268 studio units and 43-1 bedroom units contemplated to be constructed on the Hotel Space, the Entry/Garage Space and the Tower Building, and "Permitted Improvements" shall mean those improvements heretofore approved in writing by Hotel Owner (or hereafter approved by Hotel Owner in accordance with the terms of this Agreement or any other written agreement between Hotel Owner and Tower Building Owner) and constructed as part of the Initial Improvements. In the absence of actual knowledge to the contrary or a certificate recorded by Hotel Owner containing the legal description of the Tower Building and stating to the contrary, the Initial Improvements shall be presumed to have been approved by Hotel Owner upon issuance of a final certificate of occupancy therefor.

(iii) Whenever the terms "presently" or "existing" are used herein, they shall refer to the date of recording of this Agreement.

(iv) Use of the words "herein," "hereinafter," "hereinabove," "hereof" and "hereunder," in this Agreement refer to this Agreement as a whole and not merely to the particular article, section, paragraph or provision in which such words appear, unless the context otherwise requires. Whenever it is indicated in this Agreement that either Party may, shall or will perform any act, then such act shall be performed at the sole cost and expense of the performing Party unless otherwise specifically indicated to the contrary. Use of the word "including" shall be deemed illustrative and not exclusive, and shall be deemed qualified by the term "but not limited to" whenever used.

(v) Whenever in this Agreement a Party is obligated to do something that requires mortgagee consent, joinder or subordination (such as executing or joining in a document to be recorded), such Party shall, at its sole cost, cause each mortgagee or other lienor of any portion of its interest in the Property to promptly signify its consent, joinder or subordination in recordable form.

(vi) Anything in this Agreement to the contrary notwithstanding, from and after the date a declaration of condominium in respect of the Tower Building is recorded, the Tower Building Owner shall be the "Association" established in furtherance of said condominium and not individual owners of condominium units within the condominium, and any and all acts by Tower Building Owner subsequent to the recording of said declaration of condominium shall be effected, if at all, solely by said Association (acting through its Board of Directors) and shall be binding on all owners of condominium units within the Tower Building and those claiming under them, and said Association shall take all steps required to enforce the provisions of this Agreement against individual unit owners and those claiming under them. In amplification of the foregoing, from and after the date a declaration of condominium in respect of the Tower Building is recorded, under no circumstances will any owner of a condominium unit within the condominium or anyone claiming under such owner be deemed a successor in interest to the Tower Building Owner; rather, the Association shall be the sole successor in interest to the Tower Building Owner.

(vii) Whenever used in this Agreement, the term "First Institutional Mortgagee" shall mean a bank, savings and loan association, insurance company, an agency of the United States Government, the Federal National Mortgage Association ("FNMA"), the Federal Home Loan Mortgage Corporation ("FHLMC"), or any other lender

generally recognized as an institutional lender, holding a first mortgage on the Tower Building or a portion thereof.

(viii) Whenever used in this Agreement, the term "manifestly unfair", or words of similar import, means that the determination was arbitrary and has no reasonable business basis.

(i) Integration with REA. Tower Building Owner acknowledges being aware that the REA, previously entered into between Hotel Owner and Tower 2 Owner, containing terms substantially the same as those contained herein, governs Tower 2. For certain purposes, including compliance with governmental requirements and contribution toward the costs of certain shared amenities such as valet parking, Tower 2 must be considered, notwithstanding the fact that Tower 2 is not burdened by this Declaration. Hotel Owner agrees to reasonably enforce the provisions of the REA against Tower 2 Owner so that there will be integration of the handling of those matters between the Property, Tower 2 and the Hotel Space.

(j) Captions. The captions appearing in this Agreement are for convenience and reference only and in no way define, limit or describe the scope or intent of this Agreement, nor in any way affect this Agreement.

(k) No Partnership. Nothing in the Agreement shall cause the Parties in any way to be construed as a partners, joint venturers or associates of each other in the operation of the Property or subject either Party to any obligations, loss, charge or expenses connected with or arising from the operation or use of the Property by the other.

(l) Time of Essence. Time is of the essence of this Agreement as to each of the terms, conditions, obligations and performances contained herein or required hereunder.

(m) Waiver. No failure by either Party to insist upon the strict performance of any covenant, agreement, term or condition of this Agreement or to exercise any right or remedy consequent upon a breach or default thereof, no forbearance by either Party to enforce one or more of the remedies herein provided upon an event of default, and no acceptance of full or partial payment of any amount payable under this Agreement during the continuance of any such breach or default, shall constitute a waiver of any such breach or default or of such covenant, agreement, term or condition. No covenant, agreement, term or condition of this Agreement to be performed or complied with by either Party and no breach or default thereof shall be waived, altered or modified except by a written instrument executed by the other. No waiver of any breach or default shall affect or alter this Agreement, but each and every covenant, agreement, term and condition

of this Agreement shall continue in full force and effect with respect to any other then existing or subsequent breach or default thereof.

(n) Entire Agreement. This Agreement contains the entire agreement between the Parties with respect to the subject matter hereof and all negotiations between the Parties are merged herein. Without limiting the foregoing, but in furtherance thereof, the Parties acknowledge that there are no promises, inducements, assurances, agreements, guarantees, warranties, representations or solicitations, either express or implied, written or oral, except as and to the extent specifically recited and contained herein. This Agreement cannot be changed, modified or terminated orally, but only by an instrument in writing executed by the Party against whom enforcement of any waiver, change, modification or discharge is sought.

(o) Remedies Cumulative. Each right and remedy provided for in this Agreement shall be cumulative and shall be in addition to every other right or remedy provided for in this Agreement or now or hereafter existing by law. The exercise or beginning of the exercise of any one or more rights or remedies shall not preclude the simultaneous or later exercise of any or all other rights or remedies, nor shall it constitute a forfeiture or waiver of any amounts owed.

(p) Independent Covenants. Each and every covenant and agreement contained in this Agreement shall be deemed separate and independent and not dependent upon any other provisions of this Agreement and the damages for failure to perform the same shall be deemed in addition to and separate and independent of the damages accruing by reason of the breach of any other covenant contained in this Agreement.

(q) Force Majeure. If either Party is unable to fulfill, or is delayed in fulfilling, any of its obligations under this Agreement by reason of strike or other labor trouble; governmental pre-emption or priorities or other controls in connection with a national or other public emergency or shortages of fuel, supplies or labor resulting therefrom; acts of God; accident; severe adverse weather conditions; permitting or governmental inspection delays; equipment or machinery malfunction or breakdown; or any other cause beyond its reasonable control, the period of such delay or such prevention shall be deemed added to the time herein. However, the foregoing shall not delay the time period for paying any sums due under this Agreement.

(r) Construction. This Agreement shall not be construed more strictly against one Party than against the other by virtue of the fact that initial drafts may have been prepared by counsel for one of the Parties, it being recognized that this Agreement is the product of extensive negotiations between the Parties and that both Parties

have contributed substantially and materially to the final preparation of this Agreement.

(s) No Third Party Beneficiaries. The provisions contained in this Agreement are for the sole benefit of the Parties, the Designated Affiliate (where noted), and their respective successors and assigns, and shall not give rise to any rights by or on behalf of anyone other than such parties. Notwithstanding the foregoing, the City of Miami Beach is a third party beneficiary of the specific provisions set forth herein that are expressly stated herein as being for its benefit.

(t) Limitations as to Hotel Space. The Parties expressly agree that the Hotel Space is burdened by this Agreement for limited purposes only, and shall only be burdened by this Agreement as and to the extent expressly set forth herein. The Hotel Space is not a part of the Property and use of the term Property in this Agreement shall not be construed, either directly or indirectly, to in any way include the Hotel Space. No lien rights whatsoever are created under this Agreement, or shall exist, to burden the Hotel Space.

IN WITNESS WHEREOF, the undersigned has caused this instrument to be executed as of the day and year first above written.

Witnesses as to Hotel Owner:

FONTAINEBLEAU FLORIDA HOTEL,
LLC, a Florida limited liability
company

Sign Name: _____

(CORP.

Print Name: _____

By: _____ SEAL)

Sign Name: _____

Print Name: _____

STATE OF _____)

) SS:

COUNTY OF _____)

The foregoing Agreement was acknowledged before me this ____ day of _____, 200_ by _____ as _____ of Fontainebleau Florida Hotel, LLC, a Florida limited liability company, in the capacity aforesated. He/She is personally known to me or produced a driver's license as identification.

Sign Name: _____

Print Name: _____

Notary Public

My Commission Expires:

[NOTARIAL SEAL]

Witnesses as to Tower Building Owner:

Sign Name: _____ Fontainebleau Florida Tower 3, LLC, a
Print Name: _____ Florida limited liability company

Sign Name: _____ By: Fontainebleau Florida Hotel
Print Name: _____ Properties, LLC, a Florida
limited liability company and
its sole member

By: Fontainebleau Resort Properties
I, LLC, a Delaware limited
liability company and its sole
member

By: Fontainebleau Resort Holdings,
LLC, a Delaware limited
liability company and its sole
member

By: Fontainebleau Resorts, LLC, a
Delaware limited liability
company and its sole member

By: _____
Jeffrey Soffer, its Manager

STATE OF _____)
) SS:
COUNTY OF _____)

The foregoing Agreement was acknowledged before me this ____ day
of _____, 200_ by Jeffrey Soffer as Manager of Fontainebleau
Resorts, LLC, a Delaware limited liability company, sole member of
Fontainebleau Resort Holdings, LLC, a Delaware limited liability
company, sole member of Fontainebleau Resort Properties I, LLC, a
Delaware limited liability company, sole member of Fontainebleau
Florida Hotel Properties, LLC, a Florid limited liability company,
sole member of Fontainebleau Florida Tower 3, LLC, a Florida limited
liability company, in the capacity aforesated. He is personally
known to me or produced a driver's license as identification.

Sign Name: _____
Print Name: _____
Notary Public

My Commission Expires:

[NOTARIAL SEAL]

CONSENT AND JOINDER

The undersigned as owner and holder of that certain Mortgage, Assignment of Rents, Security Agreement and Fixture Filing recorded in Official Records Book _____, Page _____, of the public records of Miami-Dade County, Florida, as amended and assigned (the "Mortgage") and related security documents, does hereby consent to the execution delivery and recording of that certain Declaration of Restrictions and Reciprocal Easement Agreement to which this Consent and Joinder is attached (the "Agreement") and agrees that the undersigned's interest under the Mortgage and related security documents is and shall be subject and subordinate to the terms and conditions of the Agreement; provided, however, nothing contained herein shall subordinate or release the undersigned's interest under the Mortgage or related security documents except as specifically herein set forth and nothing contained herein shall be deemed to subordinate or have the effect of subordinating the lien of the Mortgage to any liens created, arising, filed or established pursuant to the Agreement, and the Mortgage shall at all times remain superior to any such liens created under the Agreement, and provided further that no amendment, modification, waiver or consent under the Agreement shall be effective with respect to the Mortgage or related security documents or enforceable against the undersigned unless agreed to in writing by the undersigned.

Any notices shall be delivered to the undersigned at _____, or such other address as the undersigned may designate.

IN WITNESS WHEREOF, the undersigned has executed this Consent and Joinder this _____ day of _____, 200_.

Signed, sealed and delivered
in the presence of:

Print Name: _____

Print Name: _____

Address: _____

STATE OF _____
COUNTY OF _____

I, _____, a notary public in
and for said county in said state, hereby certify that
_____, whose name as _____ of
_____ is signed to the foregoing instrument and
who is known to me, acknowledged before me on this day that, being
informed of the contents of such instrument, he, as such officer and
with full authority, executed the same voluntarily for and as the act
of said corporation.

Given under my hand and official seal this ___ day of
_____, 200_.

Notary Public, State of _____
My Commission Expires: _____

CONSENT AND JOINDER

The undersigned as owner and holder of that certain Mortgage, Assignment of Rents, Security Agreement and Fixture Filing recorded in Official Records Book _____, Page _____, of the public records of Miami-Dade County, Florida (the "Mortgage") and related security documents, does hereby consent to the execution delivery and recording of that certain Declaration of Restrictions and Reciprocal Easement Agreement to which this Consent and Joinder is attached (the "Agreement") and agrees that the undersigned's interest under the Mortgage and related security documents is and shall be subject and subordinate to the terms and conditions of the Agreement; provided, however, nothing contained herein shall subordinate or release the undersigned's interest under the Mortgage or related security documents except as specifically herein set forth and nothing contained herein shall be deemed to subordinate or have the effect of subordinating the lien of the Mortgage to any liens created, arising, filed or established pursuant to the Agreement, and the Mortgage shall at all times remain superior to any such liens created under the Agreement, and provided further that no amendment, modification, waiver or consent under the Agreement shall be effective with respect to the Mortgage or related security documents or enforceable against the undersigned unless agreed to in writing by the undersigned.

Any notices shall be delivered to the undersigned at _____, or such other address as the undersigned may designate.

IN WITNESS WHEREOF, the undersigned has caused this instrument to be executed as of the ____ day of _____, 200__.

Signed, sealed and delivered
in the presence of:

Print Name: _____

Print Name: _____

By: _____
Name: _____
Title: _____
[CORPORATE SEAL]
Address: _____

STATE OF _____)
)SS.
COUNTY OF _____)

The foregoing instrument was acknowledged before me this _____
day of _____, 200_ by _____, as
_____ of _____, in the capacity
aforestated; said person is personally know to me or produced a
driver's license as identification.

Notary Public

My Commission Expires:

(NOTARIAL SEAL)

TABLE OF CONTENTS

		Page
1.	Establishment of Easements within Property.....	2
2.	Establishment of Easements/Rights Between the Tower Building and the Hotel Space.....	5
3.	Agreement to Grant Additional Easements.....	8
4.	Limitations on Use of the Property and Easement Areas.....	8
	(a) No Barriers	8
	(b) Conduct of Work	8
	(c) Plans Availability	9
	(d) Freight Docks, Trash Elevator and Compactor Space	9
	(e) Compliance with Legal Requirements	9
	(f) Cooperation	10
	(g) Effect of Exclusive Rights and Areas Primarily Used by One Party	10
5.	Initial Construction/Renovations/Use.....	12
	(a) Standard of Work	12
	(b) Architectural Approval	12
	(c) Intentionally omitted	14
	(d) Weight Loads	14
	(e) Odors	14
	(f) Increased Insurance Costs	14
	(g) Limitations on Use of Tower Building	14
	(h) Hazardous Materials	15
	(i) Government Compliance	15
6.	Maintenance.....	18
	(a) Generally	18
	(b) Tower Building Contribution to Operating Expenses	20
	(c) Common Walls, Floors and Ceilings	21
	(d) Sump Pumps and Discharge/Deep Wells	22
	(e) Remedies	22
	(f) Indemnity	23
7.	Taxes	23
8.	Insurance and Restoration.....	24
	(a) Types of Insurance	24

(b)	Standards for Insurance	26
(c)	Remedies	26
(d)	Casualty	26
9.	Condemnation.....	28
10.	Parking.....	28
11.	"Fontainebleau" Trade Name.....	30
12.	Miscellaneous.....	30
(a)	Specific Performance	30
(b)	Prevailing Party Attorneys' Fees; WAIVER OF JURY TRIAL ..	30
(c)	Estoppel Certificates	31
(d)	No Public Dedication	31
(e)	Covenant Running with Land; Modifications	31
(f)	Notices	31
(g)	Governing Law; Invalidity; Liability After Sale; Counterparts	32
(h)	Certain Defined Terms; Construction	32
(i)	Intentionally omitted	34
(j)	Captions	34
(k)	No Partnership	34
(l)	Time of Essence	34
(m)	Waiver	34
(n)	Entire Agreement	34
(o)	Remedies Cumulative	35
(p)	Independent Covenants	35
(q)	Force Majeure	35
(r)	Construction	35
(s)	No Third Party Beneficiaries	35
(t)	Limitations as to Hotel Space	36

JOINDERS

EXHIBITS

Exhibit "A"	Legal Description for Entry/Garage Space
Exhibit "B"	Legal Description of Tower Building
Exhibit "C"	Legal Description of Hotel Space
Exhibit "D"	Site Plan

#32540 v2 3/17/2005

UNIT MANAGEMENT AGREEMENT

THIS AGREEMENT is made and entered into this day of _____, 200_, by and among Fontainebleau Florida Tower 2, LLC, Florida Limited Liability Company whose address is 4401 Collins Avenue, Miami Beach, Florida (“Agent”), _____ (“Owner”) whose address is _____ and Fontainebleau Florida Hotel, LLC a Florida Limited Liability Company (“Hotel Operator”), whose address is 4441 Collins Avenue, Miami Beach, Florida.

RECITALS

A. Agent is the owner of (or has the right to control) the Hotel Unit (as defined in the Declaration of Condominium for the Condo-Hotel, recorded in Official Records Book _____, Page _____, of the Public Records of Miami-Dade County, Florida) in Fontainebleau II, a Condominium (the “Condo-Hotel”) located at 4401 Collins Avenue, Miami Beach, Miami-Dade County, Florida;

B. The Condo-Hotel consists of approximately 230 two-bedroom two-bath lockout units and 2 penthouse units which will be, or have been, sold to individual purchasers (the “Residential Units”);

C. Owner has acquired and is the owner of or intends to acquire and become the owner of the Residential Unit(s) described below;

D. The Residential Unit owners shall have certain use rights to the public and recreational areas and switchboard of the Fontainebleau Resort & Spa (the “Hotel”), which Hotel is managed by Hotel Operator and is adjacent to the Condo-Hotel;

E. Agent has entered into or will enter into an agreement with Hotel Operator whereby Hotel Operator will, among other things, manage such Units as part of the Hotel’s inventory of rooms and suites, upon request and pursuant to individual executed rental agreements between Agent and the Residential Unit owners electing to participate in such rental program (the “Operating Agreement”);

F. Owner wishes to engage the services of Agent to act as the sole and exclusive rental agent to offer Owner’s Unit for rental as part of Hotel inventory under the Operating Agreement in accordance with the terms and conditions set forth below;

G. Agent desires to be so engaged by Owner.

NOW, THEREFORE, in consideration of Ten Dollars (\$10.00) and other good and valuable consideration, the receipt and sufficiency of which are hereby acknowledged, Owner, Agent and Hotel Operator hereby agree as follows:

1. The foregoing preamble and the Recitals are true and correct and are incorporated herein.

2. Owner agrees to make available for rental, and Agent agrees to offer for rental, Residential Unit # _____ (the "Premises") subject to the terms and conditions set forth herein.

3. The term of this Agreement shall begin on _____, 200_, and shall terminate at midnight on _____, 200_ (the "Initial Term"). This Agreement shall automatically renew for successive terms of twelve (12) months each ("Renewal Terms") unless a party provides the others with written notice of its intent not to renew at least sixty (60) days prior to the expiration of the Initial Term or any applicable Renewal Term. The Initial Term, as extended by any Renewal Term, shall hereinafter be referred to as the Term.

4. Hotel Operator shall maintain a reservation system through which all reservations will be processed both for the Hotel and for the Premises and the other Residential Units for which a Unit Management Agreement has been executed (the "Leased Units"). Owner may request reservations for the Premises for unlimited personal use ("Owner Occupancy Period"), at least sixty (60) days in advance of Owner's intended stay, and Hotel Operator agrees to honor such requests, subject to any confirmed reservations existing at the date of Owner's request.

Any request for an Owner Occupancy Period made less than sixty (60) days prior to the desired commencement of such period shall be honored, if at all, solely at the discretion of Agent.

OWNER, WITHOUT PRIOR NOTIFICATION TO, APPROVAL OF, AND COORDINATION WITH, HOTEL OPERATOR, AGREES NOT TO ENTER THE PREMISES NOR TO PERMIT ANY PERSON, WHETHER FAMILY MEMBER, REPAIRMAN, OR GUEST OCCUPANT, TO ENTER THE PREMISES, OTHER THAN DURING THOSE TIMES OF OCCUPANCY FOR WHICH OWNER HAS REQUESTED, AND HOTEL OPERATOR HAS CONFIRMED OCCUPANCY OF OWNER OR OWNER'S GUEST OCCUPANTS OF THE PREMISES. IN ALL EVENTS, ACCESS TO THE PREMISES SHALL BE COORDINATED WITH HOTEL OPERATOR, INCLUDING DURING OWNER OCCUPANCY PERIODS.

5. OWNER HEREBY GRANTS TO AGENT THE SOLE AND EXCLUSIVE AUTHORITY TO RENT THE PREMISES AT RATES HOTEL OPERATOR DEEMS APPROPRIATE. OWNER AGREES THAT ALL REMUNERATION FROM THE RENTAL OF THE PREMISES WILL BE COLLECTED THROUGH HOTEL OPERATOR SUBJECT TO THE FEE AS SPECIFIED IN PARAGRAPH 20 HEREOF.

6. Owner authorizes Hotel Operator to accept reservations for occupancy of the Premises for any length of time, except for any confirmed Owner Occupancy Periods. Without the prior consent of Owner, Hotel Operator shall not accept reservations for more than ninety (90) consecutive days; any such reservations shall be binding on Owner and will be confirmed in writing to Owner. Both Owner and Hotel Operator shall use reasonable diligence to avoid reservation conflicts, but neither Agent nor Hotel Operator shall be liable to Owner for any damages or otherwise resulting from such conflict (including, without limitation, for unavailability of the Premises during any Owner Occupancy Period due to holdover by a Hotel guest occupying the Premises).

7. Agent agrees to maintain records and to provide to Owner a quarterly or, at Agent's sole option, more frequent statement of Owner's account. The statement shall detail all

remuneration from the rental of the Premises and all charges against Owner's account as permitted and described in this Agreement. Owner shall be liable for all charges against its account (whether incurred by Owner, its family members or guest occupants, but not occupants during Hotel rental occupancy pursuant to this Agreement) and authorizes Agent to set-off all charges against any sums which are, or are to be, properly credited to Owner's account. Owner agrees to pay all charges within fifteen (15) days following receipt of a statement to the extent that such statement indicates charges against Owner's account in excess of sums credited thereto. Agent shall send together with each statement a check payable to Owner representing the amount by which the credits exceed the charges against Owner's account.

In order to assure Owner's timely payment of funds, Owner agrees to maintain a valid credit card authorization on file with Hotel Operator's Finance Department at all times as a source of funds. This card will be used to pay all expenses owed that are past due by 30 days from the date of the statement. Hotel Operator will mail Owner a copy of the receipt within thirty (30) days of each charge. Owner hereby authorizes Hotel Operator to access the credit established in this paragraph in order to meet Owner's financial obligations under this Agreement.

8. Owner shall be responsible for all charges and expenses due and owing in connection with the Premises, including, without limitation, payment of any mortgage and/or other financing costs, real and personal property taxes, all applicable insurance premiums, all condominium, access and shared costs maintenance charges as well as payment to all entities providing utility services to the Premises (to the extent separately metered), including, without limitation, all companies providing gas, telephone and water service (collectively, the "Direct Unit Expenses"). Upon request of Agent, Owner shall send to Agent appropriate evidence of payment of all such Direct Unit Expenses. Agent reserves the right, but shall not be obligated, to pay any Direct Unit Expenses on behalf of Owner, and any such payments made by Agent pursuant to this Paragraph 8 shall be charged against Owner's account.

9. Hotel switchboard telephone service shall be provided to the Premises, and Hotel Operator will be responsible for long distance charges made by a Hotel guest occupying the Premises. All other telephone or telecommunications charges, including any long distance telephone and high speed or dial-up internet charges, cable or its equivalent television charges or pay-per-view charges made during periods other than periods of Hotel rental occupancy pursuant to this Agreement (including during any Owner Occupancy Period) shall be charged against Owner's account.

10. After each Owner Occupancy Period, a standard departure cleaning shall be provided by Hotel Operator to the Premises and the standard fee therefor shall be charged against Owner's account. If a more thorough departure cleaning is required in Hotel Operator's sole discretion, an additional fee shall be charged against Owners' account in an amount determined in the sole but reasonable exercise of business judgment of Hotel Operator sufficient to cover the additional work. Hotel Operator shall undertake an annual general interior housecleaning of the Premises, in addition to the maid services described in this Paragraph 18. Such annual housecleaning shall include carpet cleaning, furniture cleaning, interior window washing and floor waxing, as applicable and required; if such services are required more frequently than annually, they may be performed by Hotel Operator and charged to Owner's account or the Reserve Account.

Additionally, during any Owner Occupancy Period, Hotel Operator, upon request of Owner, or any family members or guest occupants of Owner, shall provide daily maid service (and/or turndown service, if provided for the Hotel) to the Premises, for which the then prevailing rate of such service shall be charged against Owner's account. If Owner or its family members or guest occupants receive daily housekeeping service during each day of their stay during Owner Occupancy Periods, the standard departure cleaning charge will be waived at check-out.

11. During any Owner Occupancy Period, Owner, and any guest occupants of Owner, shall abide by the standard check-in and check-out times required by Hotel Operator (currently 3:00 p.m. check-in and 11:00 a.m. check-out, subject to change).

12. Hotel Operator, as an assistance to Owner in the promotion and rental of the Premises shall (a) conduct, at least once annually (and as needed more frequently), an inventory of all major furnishings, furniture, fixtures and equipment, (b) inspect the general condition of the Premises, and (c) provide Owner with an inventory report, a statement as to the condition of the Premises, and written recommendations for improvements to the Premises (including, without limitation, recommended refurbishments and/or interior painting). All maintenance, repairs and replacements, provided funds are available therefor in the Reserve Account (hereinafter defined) or have been authorized as provided for in Paragraph 15 below, in respect of the Premises shall be made by Hotel Operator, but, notwithstanding the foregoing, Owner shall have the ultimate financial responsibility for maintenance, repair of the Premises and replacement of the furnishings, furniture, fixtures and equipment in the Premises, and the condition thereof, so that the Premises is at all times at least to the standard of the Hotel.

13. Hotel Operator reserves the right to terminate this Agreement, on thirty (30) days written notice, should Owner fail to authorize implementation of the recommendations made pursuant to Paragraph 12 above or should Hotel Operator deem the Premises to be unsatisfactory for rental as part of Hotel inventory, such decision to be in the sole discretion of Hotel Operator. In the event that this Agreement is terminated as aforesaid, Hotel Operator shall have the right, but not the obligation, to transfer to other accommodations any confirmed reservations which are for occupancy of the Premises subsequent to such thirty (30) day period.

14. In order to initially supply the Premises with disposable operating supplies and amenities, as well as back-up inventory of linens, required by Hotel Operator for the Premises to meet the standards for rental to the transient public, Owner shall make to Hotel Operator a non-refundable Five Hundred Dollars (\$500.00) payment, payable upon execution of this Agreement.

15. In the event that Hotel Operator chooses to provide maintenance services for any major appliances serving the Premises and/or to offer a maintenance service contract, Owner shall utilize same, payment for which will be charged against Owner's account. Otherwise, to the extent that any major appliances serving the Premises are not covered by manufacturers' warranties, Owner shall obtain and maintain in force and effect a "Maintenance Agreement" with a service provider to provide twenty-four (24) hour emergency repair service for all major appliances serving the Premises. Owner shall provide a copy of said "Maintenance Agreement" to Agent together with copies of all such manufacturers' warranties. If Owner desires major repair or replacement of any interior items or furnishings which are outside the terms and conditions of the "Maintenance Agreement" or any applicable manufacturer's warranty, Agent will, on request of Owner in writing, and as Owner's agent, seek repair services or replacement; in this regard, Agent may request, in

which case Owner shall pay, a deposit of all or a portion of the estimated cost as a condition to seeking repair services or replacement, which deposit shall be added to the Reserve Account and submit the invoice therefor directly to Owner for payment or, at Agent's option, it or Hotel Operator may charge Owner's account or the Reserve Account and pay for same. Notwithstanding anything to the contrary contained herein, Agent assumes no responsibility for any maintenance, repair or replacement other than housekeeping and other services as specified in this Agreement and shall have no liability for payment of the costs associated with any such maintenance, repair or replacement.

16. Hotel Operator agrees to maintain the Premises, including all furnishings, in good repair and in rentable condition (as determined in the sole discretion of Hotel Operator), and to maintain a complement of kitchen utensils, glasses, dishes, flatware and other equipment, as specified in the "Basic Equipment List." Owner agrees that Hotel Operator may replace missing items and such other items that it reasonably determines are no longer usable and charge such costs against Owner's account or the Reserve Account; provided, however, that no more than One Thousand and No/100 Dollars (\$1,000.00) will be charged against Owner's account at any one time in this regard without first providing notice thereof to Owner. Owner agrees that it shall not make any modification to the Premises during the Term without receiving Hotel Operator's prior written consent, which consent shall not be unreasonably withheld. Owner agrees to make, at Owner's sole cost and expense, any modifications required by Agent to the locking and/or security system for the Premises in order to comply with the locking systems adopted by the Hotel Operator from time to time.

17. Owner may maintain a locked closet in the Premises for the storage of personal articles. Storage of combustibles is absolutely forbidden. Agent and Hotel Operator assume no liability for the contents of items maintained in any locked closet. Similarly, neither Agent nor Hotel Operator assumes any liability for the contents (as they may exist from time to time) in Owner's mailbox.

18. Hotel Operator agrees to provide, at Agent's expense, daily maid service (and, if provided for the Hotel, turndown service) during all periods in which the Premises are rented to a Hotel guest (except during Owner Occupancy Periods, when daily maid service and turndown service shall be provided upon the request of Owner or its family members or guest occupants, but the then prevailing rate of such services shall be charged against Owner's account). The housekeeping rates as of August 2004 are as follows:

	<u>Junior Suite</u>	<u>1 Bedroom</u>	<u>Penthouse</u>
<u>Daily Rate</u>	\$30	\$35	\$150
<u>Check-out Rate</u>	\$100	\$150	\$400

19. Owner agrees that Hotel Operator may offer a renter a reduction in the applicable Hotel rental rate in the event of a failure of the heating or air conditioning systems or a major appliance, or the failure of utility service, or a guest's complaint about noise, service and similar matters in and about the Condo-Hotel and/or the Hotel. Owner agrees that the renter may be transferred to other accommodations if such reduction in rental rate is not acceptable to the renter. In the event of such a transfer, Owner shall be credited with a pro rata share of the rental based upon the number of days of actual occupancy of the Premises. In the event the renter accepts the reduction in rental rate, the gross revenue reduction will be shared by Owner and Agent in the same

proportions as the then applicable rental revenue split. Agent and Hotel Operator hereby advise Owner, and Owner understands and agrees, that failure of the type herein discussed may periodically cause a loss of rental income.

20. For its services hereunder and as reimbursement for the rental promotion of the Premises, Agent shall be compensated, and Owner agrees to pay, a fee equal to fifty-five percent (55%) (10% off the top for fees and commissions and one-half of the balance) of all room rents.

Owner understands and agrees to contribute to the Furniture, Fixtures and Equipment Reserve (the "Reserve Account") to be maintained and administered by Agent. Such contribution shall be paid from net rentals available to Owner after payment of the fee to Agent. Owner's required contribution to the Reserve Account shall be established by Agent from time to time (currently three percent (3%) of gross room rents) and shall be commercially reasonable. Upon termination of this Agreement, any net balance remaining in the Reserve Account, after deduction of any amounts outstanding on Owner's account, shall be refunded to Owner.

Owner understands and agrees that the percentage Reserve Account fees charged under this Paragraph 20 may be changed by Agent at any time upon 60 days prior written notice. Any reservations confirmed after giving a notice changing the applicable percentage shall be subject to such revised percentage.

Upon delivery of any notice from Agent changing the percentage fees charged for rental promotion, Owner may elect, within thirty (30) days following delivery of said notice, to terminate this Agreement. If Owner timely elects to terminate this Agreement, Owner shall nonetheless be obligated to honor any reservation for the Premises made prior to Agent's receipt of Owner's notice of cancellation; provided, however, that Agent shall make reasonable efforts to transfer any reservations to alternative accommodations, and the fee payable with respect to any reservations surviving termination shall be charged at the rate in effect prior to the increase set forth in Agent's notice triggering Owner's election to terminate.

21. For rentals of thirty (30) days and longer, Hotel Operator may (but shall not be obligated to) collect from the renter a deposit in an amount determined by Hotel Operator in its sole discretion to cover possible damage, inventory losses, and telephone charges. The deposit will be maintained in Hotel Operator's account. The deposit will be returned to the renter less amounts to cover damages, inventory losses, and long distance telephone calls after receipt of all bills for damage repair, inventory losses, and telephone bills for the entire occupancy period of the renter. Hotel Operator may apply the deposit money to pay for this repair effort. Hotel Operator will not authorize repairs in excess of the deposit amount without specific written authorization from Owner, any such amounts in excess of the deposit to be charged against Owner's account. Hotel Operator's identification and repair of damage is provided solely as an accommodation to Owner and Hotel Operator assumes no responsibility for any such damage to the Premises or inventory losses, provided, however, that Hotel Operator agrees to use reasonable efforts to collect the amount of the repairs from the renter. Owner may not personally inspect the Premises between rental occupancies.

22. Owner understands and agrees that Hotel Operator (a) shall cause the Unit to participate in Hotel Operator's guest recognition program and to charge or credit the Unit with such participation during periods of guest occupancy on the same basis as all other Units; (b). may, from

time to time, change the applicable rental rates to meet prevailing market conditions;(c) may change the regularly advertised rate in circumstances such as, but not limited to, extended length of stay, group discounts, Hotel Operator or corporate discounts, package plan discounts or in similar situations when Hotel Operator deems it advantageous to charge a reduced rate; and (d) may use the Premises for up to four (4) nights per calendar year for complimentary rentals. Hotel Operator and Agent are authorized to maintain their standard promotional material package in the Premises during the term of this Agreement, which will not be disturbed by Owner.

23. Owner agrees to indemnify and hold harmless Agent and Hotel Operator, and their officers, directors, shareholders, employees and agents, from and against all claims, suits, damages, costs, losses and expenses (including attorneys' fees through all appellate levels) arising from injury to any person or property in, on or about the Premises relating to, arising from, or connected with this Agreement and/or the Premises. At Owner's sole cost and expense, Owner agrees to maintain, with an insurance company acceptable to Agent, one or more personal liability insurance policies including coverages for premises liability and against the aforementioned risks with combined single limit coverage of not less than One Million and No/100 Dollars (\$1,000,000.00). All such insurance coverages shall name Agent and Hotel Operator as an additional insured and shall provide that the policy is not cancelable and may not be materially changed until Agent has received at least thirty (30) days prior written notice thereof. Agent shall be given duplicate copies of all insurance policies containing such coverages or appropriate certificates evidencing such coverages. Notwithstanding the foregoing, if Agent or Hotel Operator offers insurance packages for persons entering into rental agreements, Owner agrees to obtain such coverage through Agent or Hotel Operator and the costs thereof may be charged to Owner's account. The amount of insurance contained in any of the aforementioned insurance coverages shall not be construed to be a limitation of the liability on the part of Owner. Owner acknowledges that losses from theft, vandalism, acts of God, the elements, or other matters beyond the control of Agent and Hotel Operator shall be borne solely by Owner.

24. Owner assumes all risk for the loss of personal property kept on the Premises. Agent and Hotel Operator shall incur no liability for the loss or damage of any such personal property. In addition, Agent and Hotel Operator shall not be liable or responsible for, or in any manner a guarantor or insurer of, the health, safety or welfare of Owner and/or any guest occupant or user of any portion of the Premises including, without limitation, Owner and Owner's guests, invitees, agents, servants, contractors or subcontractors or for any property of any such persons.

25. Upon any proper termination of this Agreement, same shall terminate Hotel Operator's authority to accept future reservations for the Premises. Owner and Owner's heirs, successors, or assigns shall be obligated to honor any reservations or commitments made during the Term and prior to the date of termination pursuant to the terms and provisions of this Agreement; provided that Hotel Operator reserves the right, but shall not be obligated, to attempt to effect a transfer to other accommodations for any confirmed reservations subsequent to said termination period.

26. It is mutually agreed that neither Agent, nor Hotel Operator, has, nor will be deemed to, guarantee, under any circumstances, (i) the level of occupancy of the Premises and/or the level of any rental revenue; or (ii) the equal distribution of rentals among all Leased Units, it being specifically understood and agreed that all Leased Units will be booked by Hotel Operator on a

rotational basis, subject to requests by potential guests for a particular view or a particular Leased Unit.

27. Owner shall inform Agent and Hotel Operator in writing if the Premises is to be put up for sale. The Premises cannot be shown for sale during periods of rental occupancy and any sale of the Premises must be subject to confirmed reservations for occupancy of the Premises and the provisions of this Agreement. Subject to the foregoing, this Agreement may be terminated upon the transfer of the Premises (by sale, foreclosure or otherwise) by notice to Agent of such sale. Until so terminated, this Agreement shall continue in full force and effect with the new owner. This Agreement shall automatically be deemed subordinate to any institutional first mortgage now or hereafter placed on the Premises, and as such, this Agreement shall not survive the foreclosure of any mortgage by any such "Institutional First Mortgage". For the purposes hereof, an Institutional First Mortgagee means a bank, savings and loan association, insurance company, real estate or mortgage investment trust, pension fund, an agency of the United States Government, mortgage banker, the Federal National Mortgage Association, the Federal Home Loan Mortgage Corporation or any other lender generally recognized as an institutional lender, holding a first mortgage on the Premises.

28. Except as specifically provided to the contrary in this Agreement, no obligations of Owner with respect to the Premises shall be assumed by Agent or Hotel Operator. Owner shall remain responsible for the payment of all assessments and other sums due the Association of the Condo-Hotel pursuant to the Declaration of the Condo-Hotel and all other documents governing the Condo-Hotel, mortgage payments, income, real property, personal property or other taxes, insurance premiums and all other obligations of Owner arising in connection with the ownership of the Premises.

29. In the event Owner fails to pay Agent any amount required under this Agreement when due, Agent shall have the right to deduct said amount from any amounts payable to Owner hereunder without notice. Similarly, in the event that Owner fails to pay any party other than Agent any amount required under this Agreement when due, Agent shall have the right, but not the obligation, to make payment to said party on behalf of Owner and to deduct said amount from the sums payable to Owner hereunder without notice.

30. This Agreement, and rental of the Premises hereunder, may subject Owner and/or Agent to the provisions, and entitle Owner and Agent to the benefits, of Chapter 509, Florida Statutes, governing hotels and restaurants and the regulations from time to time promulgated thereunder. If, and to the extent that, said Statute and/or regulations are applicable to rentals pursuant to this Agreement, Owner agrees to comply with and abide by said laws and regulations. Agent or Hotel Operator will endeavor, but shall not be obligated, to keep Owner advised from time to time with respect to the nature and extent of such laws and regulations and the measures to be taken in order to comply therewith.

31. All notices required or desired to be given under this Agreement shall be in writing and shall be deemed given when either delivered personally or deposited (i) in the United States mail, certified mail, postage prepaid, with a return receipt requested; or (ii) with a recognized overnight courier service (i.e., Federal Express, Express Mail, Emory, Purolator, United Parcel Service, etc.), to the parties at the addresses set forth in the introductory paragraph of this Agreement, or such other addresses as hereinafter indicated by appropriate written notice.

32. This Agreement shall be governed by and construed in accordance with the laws of the State of Florida, which shall control all matters relating to the execution, validity and enforcement of this Agreement. The parties agree that subject to the exclusion of intellectual property matters as set forth below, any dispute in any way arising out of or relating to this Agreement will be resolved by final and binding arbitration before JAMS or the American Arbitration Association in Miami Beach, Florida, or the closest available location; provided, however, a dispute relating to patents, trademarks, trade dress, copyrights, trade secrets, false advertising, false representation, unfair competition and/or infringement of intellectual property rights shall not be subject to this provision. The parties further agree that in any arbitration proceeding (i) they may conduct reasonable discovery pursuant to the arbitration rules and (ii) any arbitration award will be enforceable in state or federal court. The prevailing party in any arbitration, suit or other action arising out of or related to this Agreement shall be entitled to recover its reasonable fees, costs, and expenses relating to such arbitration, suit or action, including reasonable fees, expenses and disbursements for in-house counsel, outside counsel, consultants and experts, and fees, costs, and expenses relating to such action.

33. Owner understands and agrees that Agent and Hotel Operator, in administering the rental program and in renting out the Premises are each pledged to the letter and spirit of the U.S. policy for achievement of equal housing opportunity throughout the nation. Accordingly, Agent and Hotel Operator each encourage and support an affirmative program in which there are no barriers to obtaining housing because of race, color, religion, sex, handicap, familial status or national origin.

34. This Agreement contains the entire agreement of the parties hereto as of the date hereof. No waiver of any covenant or condition of this Agreement by either party shall be deemed to imply or constitute a further waiver of same or of any other covenant or condition of this Agreement. No modification, amendment, release, discharge or waiver of any provisions hereof shall be of any force, effect or value unless in writing signed by the parties to be charged. If any clause or provision of this Agreement shall be held invalid or void for any reason, such invalid or void clause or provision shall not affect the whole of this Agreement and the balance of the provisions hereof shall remain in full force and effect.

35. **Owner acknowledges and agrees that no pooling shall occur under the rental program in respect of which this Agreement is being entered into. Thus, Owner acknowledges that payment shall only be made to Owner for the rental of the Premises, and that Owner shall not receive any portion of the moneys received for rentals of other Residential Units enrolled in the rental program. Owner further acknowledges that neither Agent nor Hotel Operator, nor any of their respective affiliates, employees, agents or representatives, has (i) made any statements or representations with respect to the economic or tax benefits of ownership of the Premises, (ii) emphasized the economic or tax benefits to be derived from the enrollment of the Premises in the rental program, (iii) made any suggestion, implication, statement or representation that any pooling arrangement will exist among the participants in the rental program or that Owner will share in any way in the rental proceeds of other owners or any other person, or (v) made any suggestion, implication, statement or representation that Owner must participate in the rental program. Owner further acknowledges that (a) neither this Agreement nor any other agreement for provision of rental services was entered into prior to Owner's entering into a binding contract for purchase of the Premises, (b) Owner has had all of its questions answered and has received all requested**

information regarding the rental program, (c) Owner has been informed that Owner is not obligated to enter into this Agreement and (d) no representation has been made that this Agreement will be renewed or extended.

36. This Agreement shall be freely assignable by Agent and Hotel Operator, respectively, to the owner or operator from time to time, as applicable, of the Hotel Unit or Hotel, as applicable. Unless and until notified to the contrary by Agent in writing, Hotel Operator shall be deemed to be the agent of Agent for all purposes of this Agreement.

37. The parties knowingly, intentionally and voluntarily WAIVE TRIAL BY JURY in all matters pertaining to this Agreement or its subject matter.

IN WITNESS WHEREOF, the parties hereto have caused this Agreement to be duly executed as of the date and year first above written.

AGENT
Fontainebleau Florida Tower 2, LLC

By: _____
Name: _____
Title: _____

OWNER

By: _____
Name: _____
Title: _____

HOTEL OPERATOR
Fontainebleau Florida Hotel, LLC

By: _____
Name: _____
Title: _____

CITY OF MIAMI BEACH
BUILDING DEPARTMENT
1700 CONVENTION CENTER DR
2ND FLOOR - CITY HALL
MIAMI BEACH, FLORIDA 33139
(305) 673-7610

COMPLETE DESCRIPTION

DATE: 08-16-2005

PERMIT NUMBER: **B0504894**

STATUS: APPROVED

JOBSITE ADDRESS: **4391 COLLINS AV MBCH**
CONTRACTOR: COSCAN CONSTRUCTION, LLC
OWNER: FONTAINEBLEAU FLORIDA TOWER 3, LLC

DESCRIPTION

06-17-05 chng cntctr frm B0502390 to B0504894 / NEW CONSTRUCTION, FONTAINEBLEAU III (NEW TOWER)- 286 HOTEL CONDO 11003 SF SPA & SHELL FOR RESTAURANT & ROOM SERVICE (MIXED USED)

CITY OF MIAMI BEACH
Building Department
1700 Convention Ctr Drive, 2nd Floor
Miami Beach, Florida 33139
Inspections: (305) 673-7370 Office: (305) 673-7610

Bldg Master Permit

08-16-2005

Activity Number: B0504894

Status: APPROVED Issued By: BUILMOLS
Site Address: 4391 COLLINS AV MBCH Applied: 06/17/2005
Parcel #: 32260012130 Approved: 06/28/2005
Completed: 11/01/2005
To Expire: 11/01/2005
Valuation: \$50,000,000.00

Applicant: COSCAN CONSTRUCTION, LLC Property Owner:
FONTAINEBLEAU FLORIDA TOWER 3, LLC 19501 BISCAYNE BLVD
5555 ANGLERS AVE - SUITE 1-A AVENTURA MALL STE 400 33180
FORT LAUDERDALE, FL 33312
954-620-1000

Description: 06-17-05 chng cntrectr frm B0502390 to B0504894 /
Inspector Area: C Class Code: R2

DETAIL LIST

Alteration/Repair Fees

Alteration Bulding/Structures - Per Costs:	\$0.00	\$0.00
Awning, Canopy, Patio Cover - Per Costs:	\$0.00	\$0.00
Area Under Roof - RADON - Per Sq.Ft.:	0	\$0.00
Walk-Thru - Per Valuation:	\$0.00	\$0.00
Repairs to Building/Structure - Per Costs:	\$0.00	\$0.00
Roofing or Re-roofing - Per Sq.Ft.:	0	\$0.00
Window/Doors - Per # of:	0	\$0.00
Signs 36-4 (Writer/Erect) - Per Sq.Ft.:	0	\$0.00
Fence and/or Wall - Per Linear Feet:	0	\$0.00
Partial Demo (Struct, Sign, Wall) - Per Costs:	\$0.00	\$0.00
Swimming Pool - Per Gallon:	0	\$0.00
Painting - Per Costs:	\$0.00	\$0.00
Sandblasting - Per Costs:	\$0.00	\$0.00
Paving - Per Sq.Ft.:	0	\$0.00
Concrete Slab - No Paving - Per Sq.Ft.:	0	\$0.00
Trees - Per # of:	0	
Hedges - Per Linear Feet:	0	
Groundcover - Per Sq.Ft.:	0	
Landscaping Fee:		\$0.00
Other Fees:		\$0.00
Penalty Fee (If Applicable):		\$0.00

Activity Number: B0504894

Fire Safety Fees

New Building or Addition - Per Sq.Ft.:	0	\$0.00
Storage/Industrial Bldg - E & F Occup - Per Sq.Ft.:	0	\$0.00
Greenhouse/Argiculture on Premises - Per Sq.Ft.:	0	\$0.00
Screen Enclsoure/Trail on Premises - Per Sq.Ft.:	0	\$0.00
SS Underground Tanks/App Shelter - Per #:	0	\$0.00
Construction not shown Above - Per Costs:	\$0.00	\$0.00
Alt/Repair Building/Structure - Per Costs:	\$0.00	\$0.00

Marine Structure Fee

Dock Area - Per Sq.Ft.:	0	\$0.00
Seawall - Per Linear Feet:	0	\$0.00
Boat Lifts, Davits, Hoist - Per # of:	0	\$0.00
Batter, Mooring, Dock Piles - Per # of:	0	\$0.00
Marine Structure Alt/Repair - Per Costs:	\$0.00	\$0.00

SFBC Compliance Surcharge

New Const/Add - Res/Mult-Fam/Comm - Per Sq.Ft.:	0	\$0.00
New Const/Add - Strg/Ind/Msc - Per Sq.Ft.:	0	\$0.00
Cost for Other Construction:		\$0.00

Training Fee

Training Fee:		\$0.00
Sanitation Fee:		\$0.00

Additional Fees

1st Reinspection:		\$0.00
Continued Reinspections - Per # of:	0	\$0.00
Building Joint Inspections - Per # of:	0	\$0.00
Change of Contractor Per # of:	0	\$0.00
Permit Extension - Per # of:	0	\$0.00

Residential Card:		
Commercial Card:		
Permit Card Replacements:		\$0.00

Lost Plan Fee - SF:		\$0.00
Lost Plan Fee - Other:		\$0.00
Overtime Inspection Fees:		<u>\$0.00</u>

Total of All Fees:		\$565.00
Total of Payments:		\$565.00
Balance Due:		\$0.00

See

FB III

Brochure

**FONTAINEBLEAU III
ELECTRIC BILLING COMPARISON
RESIDENTIAL RATE COMPARED TO GSD - 1
ESTIMATED ANNUAL SAVINGS**

GENERAL SERVICE DEMAND

VS RESIDENTIAL

CUSTOMER CHARGE \$390.48
(Based on 1 bill)

CUSTOMER CHARGE \$19,390.80
(Based on 286 bills)

ENERGY CHARGE

ENERGY CHARGE

4,118,400 KWH X \$0.0155 \$63,835.20
(286 x 1200 x 12)

1st 750 per unit
2,574,000 KWH X \$0.04116 \$105,945.84

KWH over 750
1,544,400 KWH X \$0.05046 \$77,930.42

FUEL CHARGE

FUEL CHARGE

4,118,400 KWH X \$0.02732 \$112,514.69

Total

4,118,400 KWH X \$0.027320 \$112,514.69

DEMAND CHARGE

DEMAND CHARGE

9500 KW X \$8.16 \$77,520.00

NA

TOTAL ELECTRIC COST **\$254,260.37**

TOTAL ELECTRIC COST **\$315,881.75**

SAVINGS ON NEW RATE

\$61,621.38

(Savings Calculated on Electric Costs Prior to Other Misc Charges)
(Savings Calculated for Occupancy Units Only - Not Common Areas)

Holiday Villas II

June 16, 2003

Marc Mazo
Power Check Consultants
14252 Puffin Court
Clearwater, Fl 33762

Dear Marc:

I have no problem letting the Florida Public Service Commission know that we believe their decision to allow Holiday Villas II to master meter the resort was a positive step for energy conservation.

Holiday Villas II is extremely pleased with our master metering system. As a result of receiving one electric bill each month for all units, it is much easier to track usage. This helps identify problem areas and make corrections much faster than if we had to wait for our investor/owners who do not live in the units to receive their bill, analyze it, and then let us know if there appears to be a problem.

In addition, by receiving one master bill for all the units the awareness of the electricity expense has increased. We are now more inclined to take steps to conserve energy that will help save money. Management is more actively seeking ideas or methods that we can implement to reduce energy usage and lower costs. It is also much easier to motivate our staff to improve their energy conservation efforts such as better thermostat control in unoccupied units, and closing of the sun protection blinds after guest departure.

If there is anything else you would like to know please do not hesitate to call.

Yours very truly,

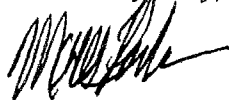

Marcus Paula
Manager

Exhibit "11"

SUNDESTIN RESORT
1040 E HWY 98
DESTIN, FL 32540

June 12, 2003

Marc Mazo
Power Check Consultants
14252 Puffin Court
Clearwater, FL 33762

Dear Marc:

As you are aware, it took a little longer than we anticipated accomplishing the conversion to master metering; however, it appears to be a positive step for the resort that will lead to reduced energy consumption and lower electricity bills.

Based on the conversion, the homeowners' association now includes the cost of electricity for the units as a common expense within its annual budget. When individually metered, the cost of electricity for each unit was part of the association common expenses. As manager of the resort, I am responsible for operating within the budget guidelines adopted by the board of directors. Based on the inclusion of the electric within the annual budget I have become more attuned to watching this expense. Now that we receive one master electric bill for the units, it has heightened my awareness of this expense and helped generate more interest by me and our staff in insuring that steps are taken to reduce energy consumption where ever and when ever possible.

Housekeeping staff regularly helps our energy conservation efforts by closing curtains on the sun side of the resort after cleaning a unit, and by setting AC thermostats back to higher levels after guests have lowered them below what is necessary to cool the unit. Maintenance and engineering staff are now more motivated to accomplish preventive maintenance, and to quickly correct any problems identified by housekeeping that might create unnecessary use of electricity.

It is my opinion that for resorts that operate in a manner similar to hotels, regardless of whether they have some permanent occupants, or not, master metering will help conserve energy and reduce the costs of electricity.

Yours very truly,

Lino Maldonado

Lino Maldonado
General Manager

FPSC Exhibit "12"

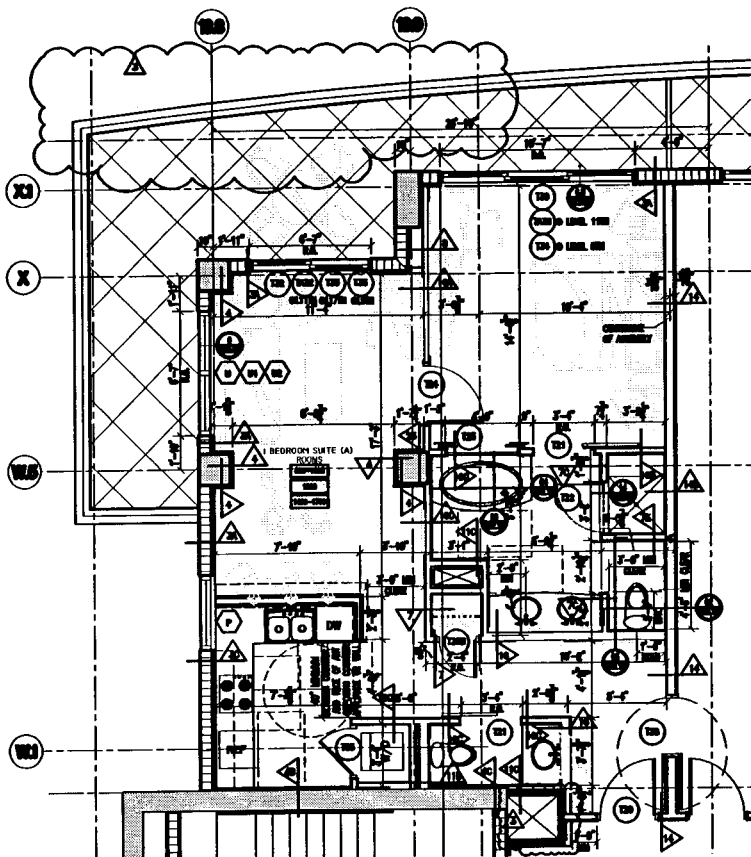

101 CONDOMINIUM RESIDENCE A @ LEVELS 5-10, 12, 14-17
SCALE: 1/8" = 1'-0"

NOTE: -- DENOTES HEARING IMPAIRED

NOTE: ALL DWELLING UNITS MUST CONTAIN REINFORCEMENT AROUND TOILETS, TUBS, AND SHOWERS IN BATHROOM WALLS TO ALLOW INSTALLATION OF GRAB BARS, TUB AND SHOWER SEAT FOR ADA UNITS ON LATER INSTALLATION OF GRAB BARS AND SHOWER SEAT FOR NON-ADA UNITS. AREA TO RECEIVE REINFORCEMENT TO BE MINIMUM 20 GA. STUD.

FOR TOILET GRAB BAR REINFORCEMENT SEE DETAILS: 2 & 3 ON SHEET A12.10
FOR TUB GRAB BAR AND SEAT REINFORCEMENT SEE DETAILS: 5, 6, 7 & 8 ON SHEET A12.10
FOR SHOWER GRAB BAR AND SEAT REINFORCEMENT SEE DETAILS: 9, 10, 11 ON SHEET A12.10

HEARING IMPAIRED:

- TELEPHONE AND TELEVISION RECEPTION SHALL USE A VIBRO FLAME COMPASS TO THE MAXIMUM EXTENT POSSIBLE. ALTERNATE RECEPTION METHODS SHALL BE PROVIDED FOR UNITS WITH TELEPHONE RECEPTION AT THE TIME OF CONSTRUCTION AND SHALL BE SUCH AS A DEAF LINE OR A VIBRO FLAME COMPASS TO THE MAXIMUM EXTENT POSSIBLE. THE VIBRO FLAME COMPASS SHALL BE PROVIDED IN ALL NEW UNITS AT THE TIME OF CONSTRUCTION. IN ALL EXISTING UNITS, THE VIBRO FLAME COMPASS SHALL BE PROVIDED IN ALL NEW UNITS AT THE TIME OF CONSTRUCTION. IN ALL EXISTING UNITS, THE VIBRO FLAME COMPASS SHALL BE PROVIDED IN ALL NEW UNITS AT THE TIME OF CONSTRUCTION.
- TELEPHONE AND TELEVISION RECEPTION SHALL ALSO BE PROVIDED TO VIBRO FLAME COMPASS TO THE MAXIMUM EXTENT POSSIBLE. THE VIBRO FLAME COMPASS SHALL BE PROVIDED IN ALL NEW UNITS AT THE TIME OF CONSTRUCTION. IN ALL EXISTING UNITS, THE VIBRO FLAME COMPASS SHALL BE PROVIDED IN ALL NEW UNITS AT THE TIME OF CONSTRUCTION.
- THE INSTALLATION OF BATHROOM GRAB BARS (INCLUDING TUB GRAB BARS AND SEAT REINFORCEMENT AND SHOWER GRAB BARS AND SEAT REINFORCEMENT) SHALL BE PROVIDED IN ALL NEW UNITS AT THE TIME OF CONSTRUCTION. THE VIBRO FLAME COMPASS SHALL BE PROVIDED IN ALL NEW UNITS AT THE TIME OF CONSTRUCTION.

GENERAL ACCESSIBILITY NOTES:

- GRAB BARS PROVIDED AT SHOWER ENTRY CROSS.
- ALL SHOWER ENTRY GRAB BARS SHALL BE AT A HEIGHT OF 36" TO 42" FROM THE FLOOR TO THE CENTER OF THE BAR. THE GRAB BARS SHALL BE PROVIDED IN ALL NEW UNITS AT THE TIME OF CONSTRUCTION. IN ALL EXISTING UNITS, THE GRAB BARS SHALL BE PROVIDED IN ALL NEW UNITS AT THE TIME OF CONSTRUCTION.
- ALL NEW UNITS SHALL HAVE TUBS TO PERMIT ACCESS BY WHEELCHAIR.

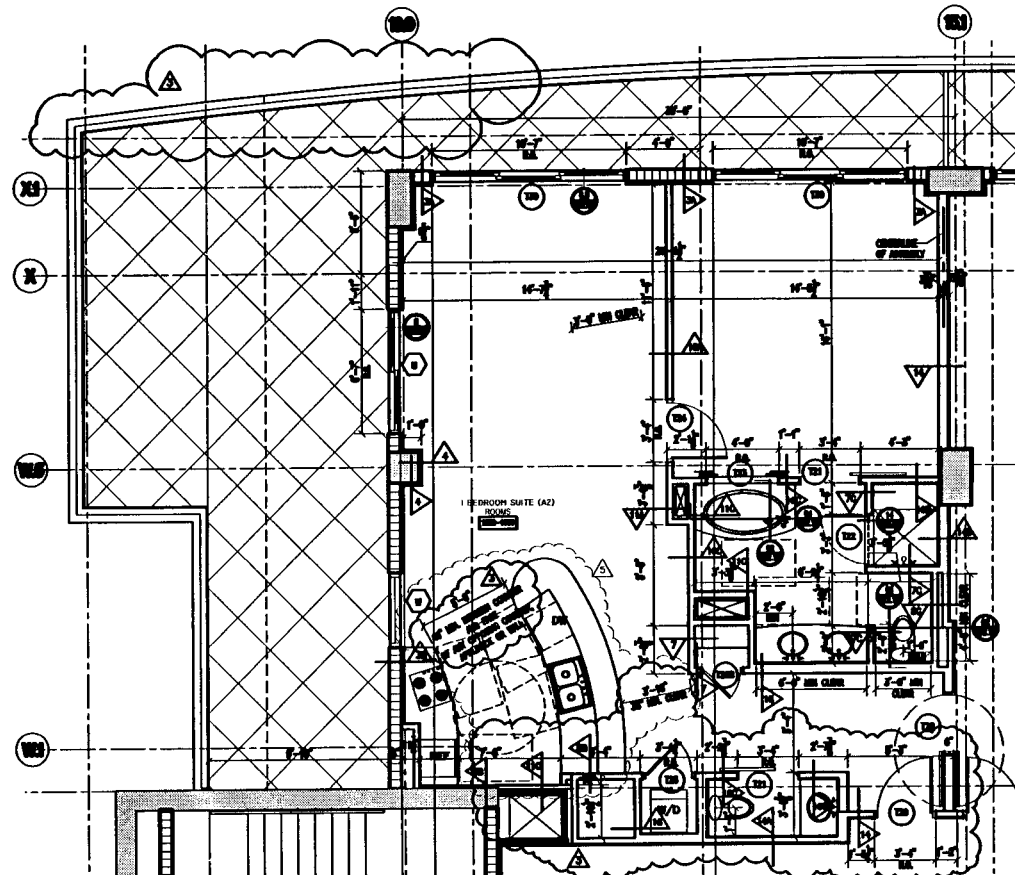

102 CONDOMINIUM RESIDENCE A2 @ LEVELS 18 & 19
SCALE: 1/8" = 1'-0"

NOTE: -- DENOTES HEARING IMPAIRED

NOTE: ALL DWELLING UNITS MUST CONTAIN REINFORCEMENT AROUND TOILETS, TUBS, AND SHOWERS IN BATHROOM WALLS TO ALLOW INSTALLATION OF GRAB BARS, TUB AND SHOWER SEAT FOR ADA UNITS ON LATER INSTALLATION OF GRAB BARS AND SHOWER SEAT FOR NON-ADA UNITS. AREA TO RECEIVE REINFORCEMENT TO BE MINIMUM 20 GA. STUD.

FOR TOILET GRAB BAR REINFORCEMENT SEE DETAILS: 2 & 3 ON SHEET A12.10
FOR TUB GRAB BAR AND SEAT REINFORCEMENT SEE DETAILS: 5, 6, 7 & 8 ON SHEET A12.10
FOR SHOWER GRAB BAR AND SEAT REINFORCEMENT SEE DETAILS: 9, 10, 11 ON SHEET A12.10

UNIT TYPE	HEARING IMPAIRED standard	HEARING IMPAIRED SOURCE	SPECIAL ACCESSIBLE TV	ADA WITH ROLL IN SHOWER 1008"	ADA WITH TUB 1908"
One bedroom A ADA					
One bedroom B	1514				
Studio D		502			
Studio D - special accessible			1684	1504"	
Studio D ADA					602
Studio DA ADA					1503
Studio E2	601		1911		
Studio E				912	1412
Studio E ADA	1216				
Studio F	1416				
Studio F - special accessible			916	1316	
Studio F ADA					1816
Studio G ADA				313	716
Studio G2	418"				
Studio I - special accessible			416		
One bedroom L ADA					523"
Studio N ADA					310

ADA UNIT CALCULATION:
In accordance with 11-9-7.2 of the Florida Accessibility Code of The Florida Building Code. Calculations were based on sheet on page 11.43.
For hotel with 261,300 rooms: (Fontainebleau III = 286)
7 fully accessible rooms required
3 fully accessible rooms with roll in shower required
In addition:
9% total number of rooms - fully accessible rooms provided - number of special accessible rooms req'd
54(286) - 10 = 5 special accessible required

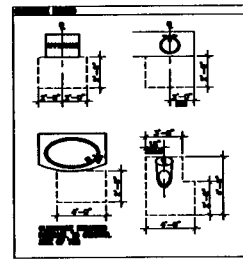

NICHOLS BOSCH WOLFE
ARCHITECTS
409 COLLINS AVENUE, MIAMI BEACH, FL 33146

Fontainebleau III
OCEAN CLUB

07-22-2005
2285

A-500

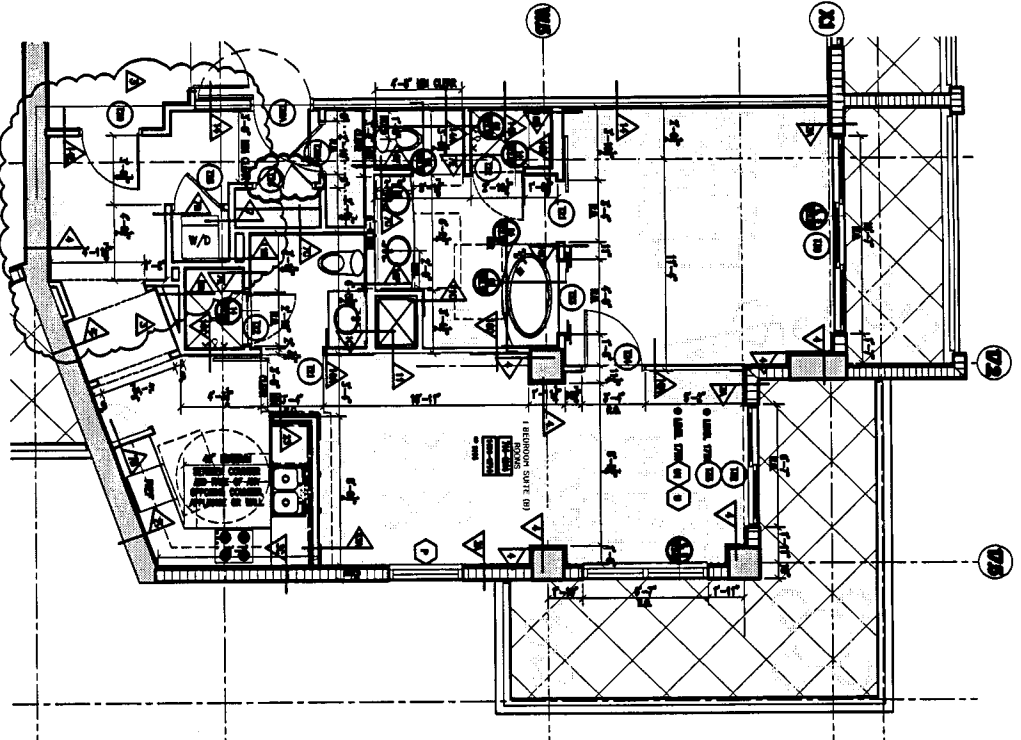

B1 CONDOMINIUM RESIDENCE B1 @ LEVELS 7-12 & 14-17
SCALE: 1/8" = 1'-0"

NOTE: -- DENOTES HEAVING MARKED
 FROM THE CHINA BATH AND SINK REFINISHMENT
 SEE DETAILS 9, 10, 11 ON SHEET A-1.10
 FROM SHOWER CHINA BATH AND SINK REFINISHMENT
 SEE DETAILS 5, 6, 7, 8 ON SHEET A-1.10
 FROM THE CHINA BATH AND SINK REFINISHMENT
 SEE DETAILS 9, 10, 11 ON SHEET A-1.10

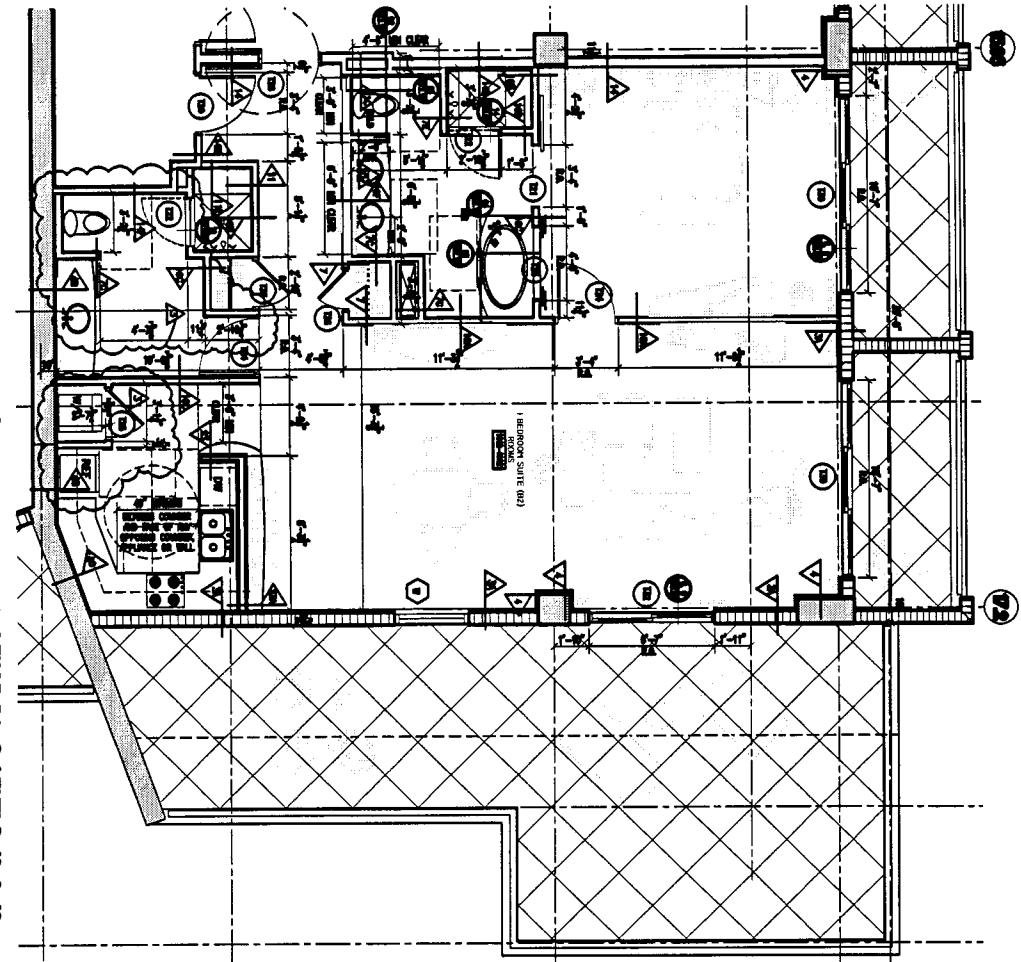

B2 CONDOMINIUM RESIDENCE B2 @ LEVELS 18 & 19
SCALE: 1/8" = 1'-0"

NOTE: -- DENOTES HEAVING MARKED
 FROM THE CHINA BATH AND SINK REFINISHMENT
 SEE DETAILS 9, 10, 11 ON SHEET A-1.10
 FROM SHOWER CHINA BATH AND SINK REFINISHMENT
 SEE DETAILS 5, 6, 7, 8 ON SHEET A-1.10
 FROM THE CHINA BATH AND SINK REFINISHMENT
 SEE DETAILS 9, 10, 11 ON SHEET A-1.10

GENERAL NOTES:
 1. ALL DIMENSIONS ARE TO FACE UNLESS NOTED OTHERWISE.
 2. ALL DIMENSIONS ARE TO FACE UNLESS NOTED OTHERWISE.
 3. ALL DIMENSIONS ARE TO FACE UNLESS NOTED OTHERWISE.
 4. ALL DIMENSIONS ARE TO FACE UNLESS NOTED OTHERWISE.

FINISHES:
 1. FLOORING: SEE FINISH SCHEDULE.
 2. WALLS: SEE FINISH SCHEDULE.
 3. CEILING: SEE FINISH SCHEDULE.
 4. DOORS: SEE FINISH SCHEDULE.
 5. WINDOWS: SEE FINISH SCHEDULE.

ALL ELEVATION MARKS REFER TO M.G.V.D.

DATE	01-13-2005
NO.	2285
PROJECT	A-1.01

NO.	DATE	DESCRIPTION
1	01-13-2005	ISSUED FOR PERMIT
2	01-13-2005	ISSUED FOR CONSTRUCTION
3	01-13-2005	ISSUED FOR RECORD

Fontainebleau III
 OCEAN CLUB
 4391 COLLINS AVENUE, MIAMI BEACH, FL 33146



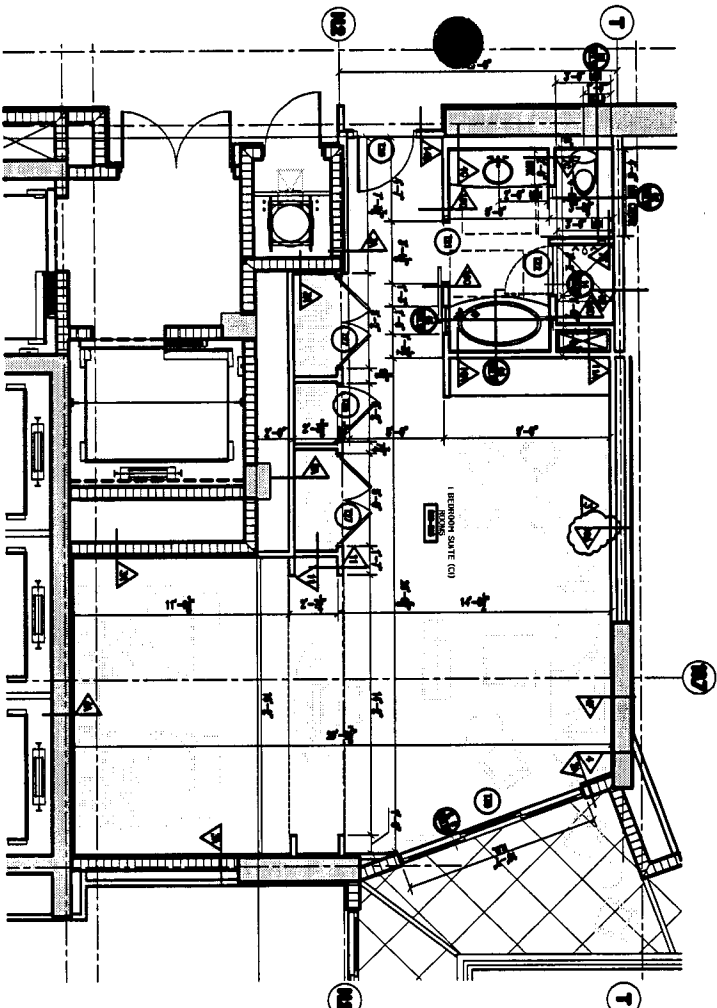

C1 CONDOMINIUM RESIDENCE C1 @ LEVELS 8-8
SCALE OF 1/4" = 1'-0"

NOTE - IDENTITIES BEARING AHEAD
 ALL DIMENSIONS UNLESS OTHERWISE SPECIFIED ARE IN FEET AND INCHES TO THE NEAREST 1/16"
 AND SHOWN IN PLACE FOR THE INSTALLATION OF CONCRETE, STAIR
 AND SHEET PILE FOR NON-FINISHED UNITS. REVISIONS TO BE SHOWN AS SHOWN ON SHEET 1917
 FOR THE GROUND AND 2 1/2" DIA. SHEET PILE
 FOR THE GROUND AND 2 1/2" DIA. SHEET PILE
 FOR THE GROUND AND 2 1/2" DIA. SHEET PILE
 FOR THE GROUND AND 2 1/2" DIA. SHEET PILE

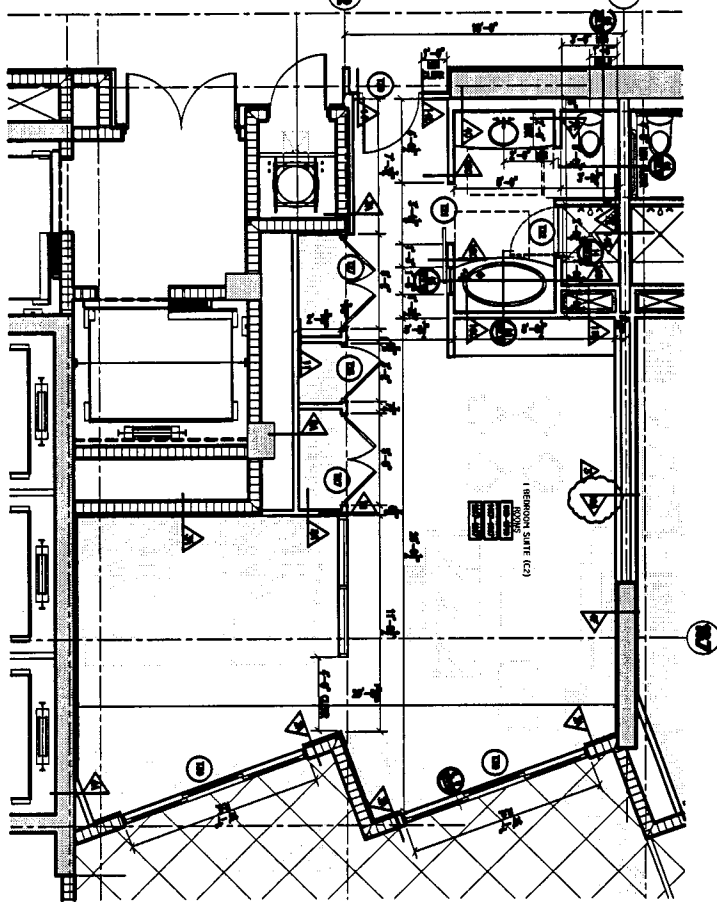

C2 CONDOMINIUM RESIDENCE C2 @ LEVELS 8-12, 14-18
SCALE OF 1/4" = 1'-0"

NOTE - IDENTITIES BEARING AHEAD
 ALL DIMENSIONS UNLESS OTHERWISE SPECIFIED ARE IN FEET AND INCHES TO THE NEAREST 1/16"
 AND SHOWN IN PLACE FOR THE INSTALLATION OF CONCRETE, STAIR
 AND SHEET PILE FOR NON-FINISHED UNITS. REVISIONS TO BE SHOWN AS SHOWN ON SHEET 1917
 FOR THE GROUND AND 2 1/2" DIA. SHEET PILE
 FOR THE GROUND AND 2 1/2" DIA. SHEET PILE
 FOR THE GROUND AND 2 1/2" DIA. SHEET PILE
 FOR THE GROUND AND 2 1/2" DIA. SHEET PILE

GENERAL NOTES:

1. REFER TO SHEET 1917 FOR THE SCHEDULE OF FINISHES AND MATERIALS TO BE USED.
2. REFER TO SHEET 1917 FOR THE SCHEDULE OF FINISHES AND MATERIALS TO BE USED.
3. REFER TO SHEET 1917 FOR THE SCHEDULE OF FINISHES AND MATERIALS TO BE USED.
4. REFER TO SHEET 1917 FOR THE SCHEDULE OF FINISHES AND MATERIALS TO BE USED.

GENERAL NOTES:

1. REFER TO SHEET 1917 FOR THE SCHEDULE OF FINISHES AND MATERIALS TO BE USED.
2. REFER TO SHEET 1917 FOR THE SCHEDULE OF FINISHES AND MATERIALS TO BE USED.
3. REFER TO SHEET 1917 FOR THE SCHEDULE OF FINISHES AND MATERIALS TO BE USED.
4. REFER TO SHEET 1917 FOR THE SCHEDULE OF FINISHES AND MATERIALS TO BE USED.

ALL ELEVATION MARKS REFER TO G.V.D.

A-6.02

DATE: 12-20-85

2285

NO.	DATE	DESCRIPTION

Fantainebleau III
OCEAN CLUB

4391 COLLINS AVENUE, MIAMI BEACH, FL 33140

NIHOYS
MOOCH
WOLF
WOLF

NIHOYS
MOOCH
WOLF
WOLF

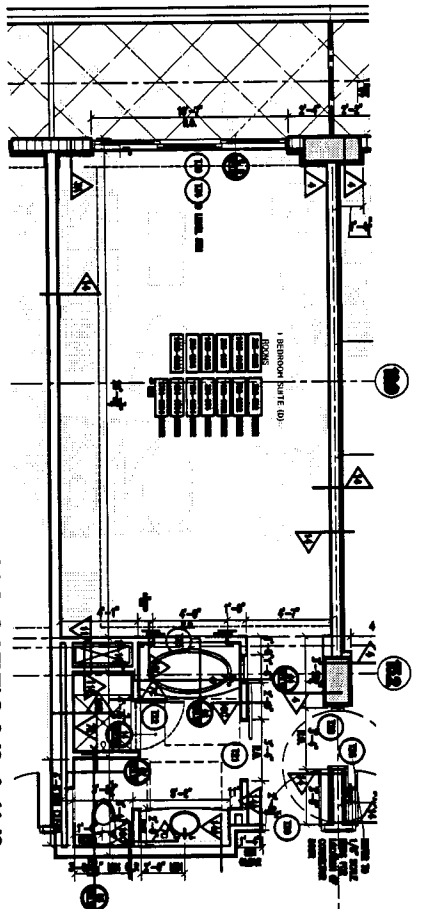

CONDOMINIUM RESIDENCE D @ LEVELS 8, 9-12, & 14-19
SCALE: 1/8" = 1'-0"

NOTE: - DENOTES VEHICULAR PARKING
NOTE: ALL DWELLING UNITS MUST CONTAIN REINFORCEMENT AROUND TOILETS, TUBS, AND SHOWERS IN ALL ROOMS TO ALLOW FOR INSTALLATION OF CAST IN-SITU CONCRETE SHOWER SEAT FOR NON-ADULTS, AREA TO RECEIVE REINFORCEMENT TO BE REMOVED FOR CLOSING.
FOR THE GRANITE BATH AND SEAT REINFORCEMENT FOR SHOWER AND SEAT REINFORCEMENT SEE DETAILS 9, 10, 11 ON SHEET A-10.
SEE DETAILS 9, 10, 11 ON SHEET A-10.

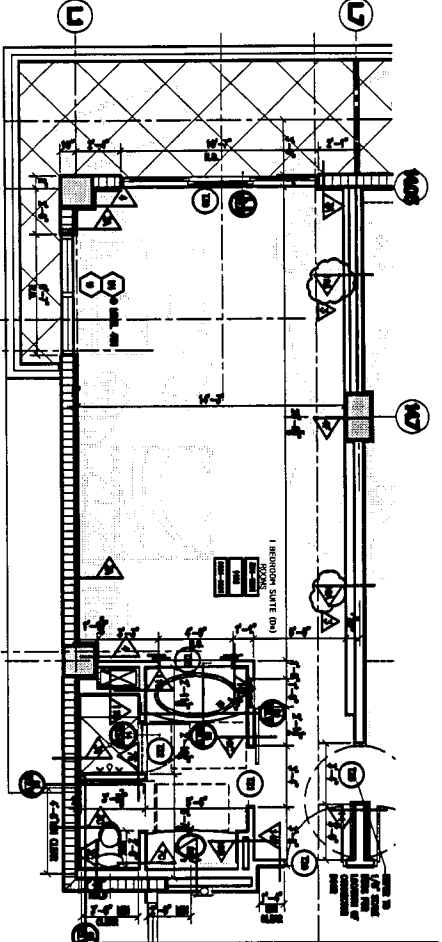

CONDOMINIUM RESIDENCE D @ LEVEL 8, 9-12, & 14-19
SCALE: 1/8" = 1'-0"

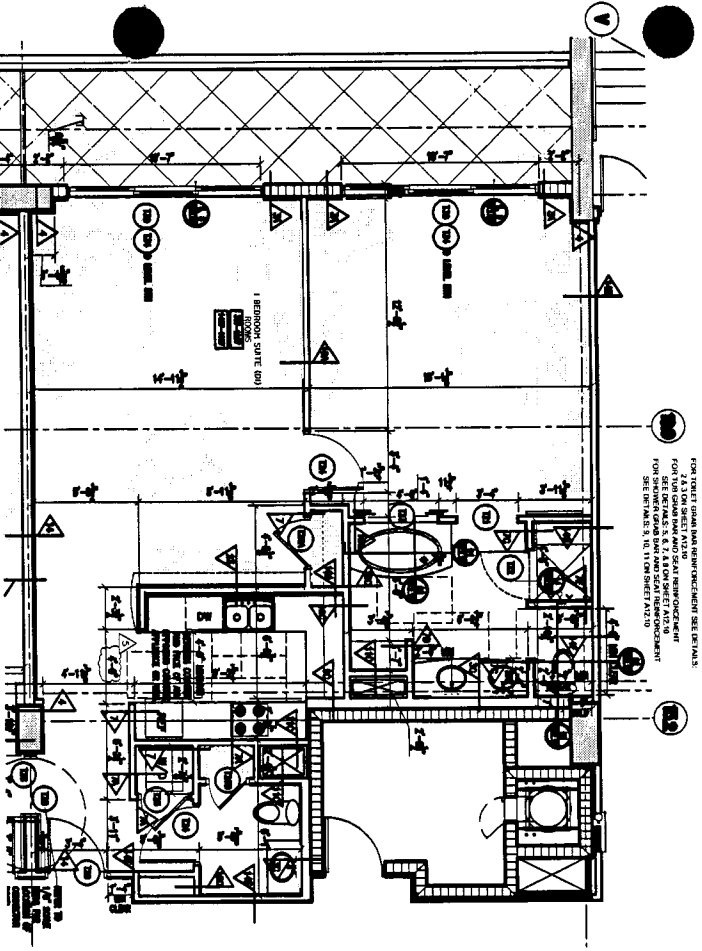

CONDOMINIUM RESIDENCE D1 @ LEVELS 8, 9-12, & 14-19
SCALE: 1/8" = 1'-0"

NOTE: - IDENTIFY REBAR NUMBER
NOTE: ALL DWELLING UNITS MUST CONTAIN REINFORCEMENT AROUND TOILETS, TUBS, AND SHOWERS IN ALL ROOMS TO ALLOW FOR INSTALLATION OF CAST IN-SITU CONCRETE SHOWER SEAT FOR NON-ADULTS, AREA TO RECEIVE REINFORCEMENT TO BE REMOVED FOR CLOSING.
FOR THE GRANITE BATH AND SEAT REINFORCEMENT FOR SHOWER AND SEAT REINFORCEMENT SEE DETAILS 9, 10, 11 ON SHEET A-10.
SEE DETAILS 9, 10, 11 ON SHEET A-10.

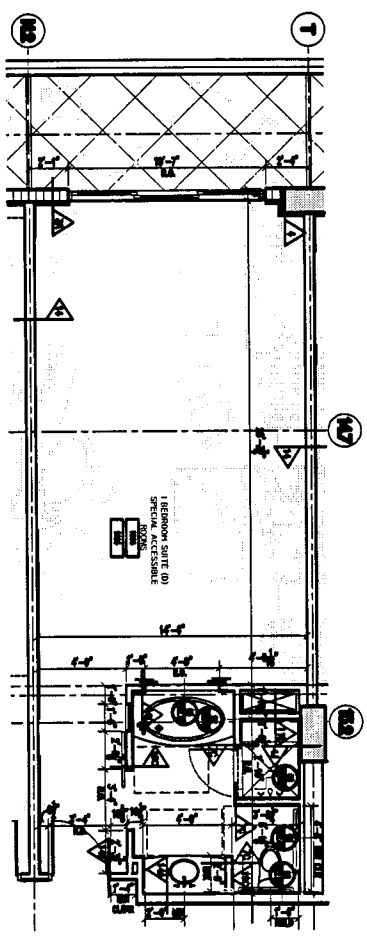

SPECIAL ACCESSIBLE CONDOMINIUM RESIDENCE D @ LEVELS 8, 9, & 19
SCALE: 1/8" = 1'-0"

NOTE: - IDENTIFY REBAR NUMBER
NOTE: ALL DWELLING UNITS MUST CONTAIN REINFORCEMENT AROUND TOILETS, TUBS, AND SHOWERS IN ALL ROOMS TO ALLOW FOR INSTALLATION OF CAST IN-SITU CONCRETE SHOWER SEAT FOR NON-ADULTS, AREA TO RECEIVE REINFORCEMENT TO BE REMOVED FOR CLOSING.
FOR THE GRANITE BATH AND SEAT REINFORCEMENT FOR SHOWER AND SEAT REINFORCEMENT SEE DETAILS 9, 10, 11 ON SHEET A-10.
SEE DETAILS 9, 10, 11 ON SHEET A-10.

GENERAL NOTES:
1. ALL DIMENSIONS ARE TO FACE UNLESS NOTED OTHERWISE.
2. ALL DIMENSIONS ARE TO FACE UNLESS NOTED OTHERWISE.
3. ALL DIMENSIONS ARE TO FACE UNLESS NOTED OTHERWISE.
4. ALL DIMENSIONS ARE TO FACE UNLESS NOTED OTHERWISE.
5. ALL DIMENSIONS ARE TO FACE UNLESS NOTED OTHERWISE.
6. ALL DIMENSIONS ARE TO FACE UNLESS NOTED OTHERWISE.
7. ALL DIMENSIONS ARE TO FACE UNLESS NOTED OTHERWISE.
8. ALL DIMENSIONS ARE TO FACE UNLESS NOTED OTHERWISE.
9. ALL DIMENSIONS ARE TO FACE UNLESS NOTED OTHERWISE.
10. ALL DIMENSIONS ARE TO FACE UNLESS NOTED OTHERWISE.
11. ALL DIMENSIONS ARE TO FACE UNLESS NOTED OTHERWISE.
12. ALL DIMENSIONS ARE TO FACE UNLESS NOTED OTHERWISE.
13. ALL DIMENSIONS ARE TO FACE UNLESS NOTED OTHERWISE.
14. ALL DIMENSIONS ARE TO FACE UNLESS NOTED OTHERWISE.
15. ALL DIMENSIONS ARE TO FACE UNLESS NOTED OTHERWISE.
16. ALL DIMENSIONS ARE TO FACE UNLESS NOTED OTHERWISE.
17. ALL DIMENSIONS ARE TO FACE UNLESS NOTED OTHERWISE.
18. ALL DIMENSIONS ARE TO FACE UNLESS NOTED OTHERWISE.
19. ALL DIMENSIONS ARE TO FACE UNLESS NOTED OTHERWISE.
20. ALL DIMENSIONS ARE TO FACE UNLESS NOTED OTHERWISE.

ALL ELEVATION MARKS REFER TO NVD

A-103 01-17-2005 2285

Fontainebleau III OCEAN CLUB
491 COLLINS AVENUE, MIAMI BEACH, FL 33140

ARCHITECT
INTERIOR ARCHITECT
MECHANICAL ENGINEER
ELECTRICAL ENGINEER
PLUMBING ENGINEER
STRUCTURAL ENGINEER

REINFORCING BARS:

1. ALL REINFORCING BARS SHALL BE #4.
2. ALL REINFORCING BARS SHALL BE EPOXY COATED UNLESS OTHERWISE NOTED.
3. ALL REINFORCING BARS SHALL BE DEVELOPED AS SHOWN IN THE REINFORCING DETAIL SHEETS.
4. ALL REINFORCING BARS SHALL BE DEVELOPED AS SHOWN IN THE REINFORCING DETAIL SHEETS.
5. ALL REINFORCING BARS SHALL BE DEVELOPED AS SHOWN IN THE REINFORCING DETAIL SHEETS.

REINFORCING BARS:

1. ALL REINFORCING BARS SHALL BE #4.
2. ALL REINFORCING BARS SHALL BE EPOXY COATED UNLESS OTHERWISE NOTED.
3. ALL REINFORCING BARS SHALL BE DEVELOPED AS SHOWN IN THE REINFORCING DETAIL SHEETS.
4. ALL REINFORCING BARS SHALL BE DEVELOPED AS SHOWN IN THE REINFORCING DETAIL SHEETS.
5. ALL REINFORCING BARS SHALL BE DEVELOPED AS SHOWN IN THE REINFORCING DETAIL SHEETS.

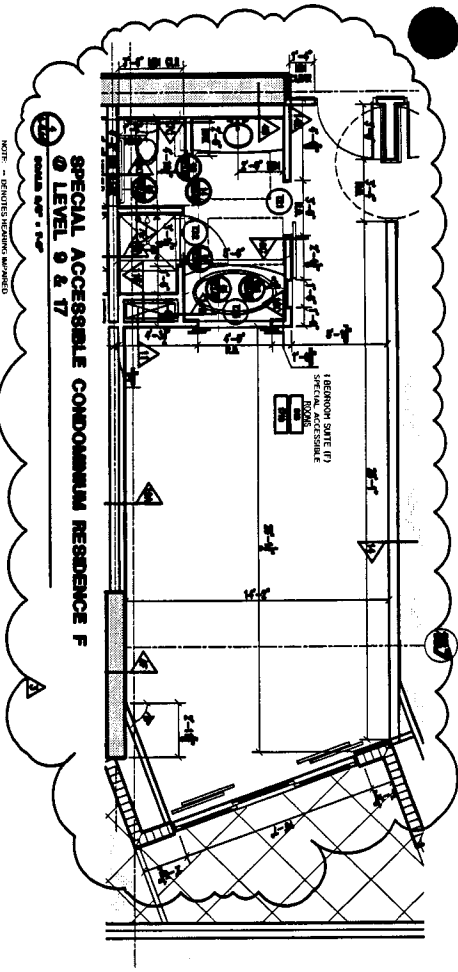

NOTE: - DENOTES REINFORCING BARS

ALL DWELLING UNITS MUST CONTAIN REINFORCEMENT ACCORDING TO THE TABLE AND SHOWN IN THE REINFORCING DETAIL SHEETS. THE REINFORCEMENT SHALL BE INSTALLED IN ALL UNITS ON LATER INSTALLATION OF CONCRETE AND SHALL BE INSTALLED IN ALL UNITS PRIOR TO THE INSTALLATION OF CONCRETE.

FOR TOILET GRAB BAR REINFORCEMENT SEE DETAILS.

FOR SHOWER GRAB BAR AND SEAT REINFORCEMENT SEE DETAILS.

FOR SEAT BELT AND SEAT REINFORCEMENT SEE DETAILS.

FOR SEAT BELT AND SEAT REINFORCEMENT SEE DETAILS.

FOR SEAT BELT AND SEAT REINFORCEMENT SEE DETAILS.

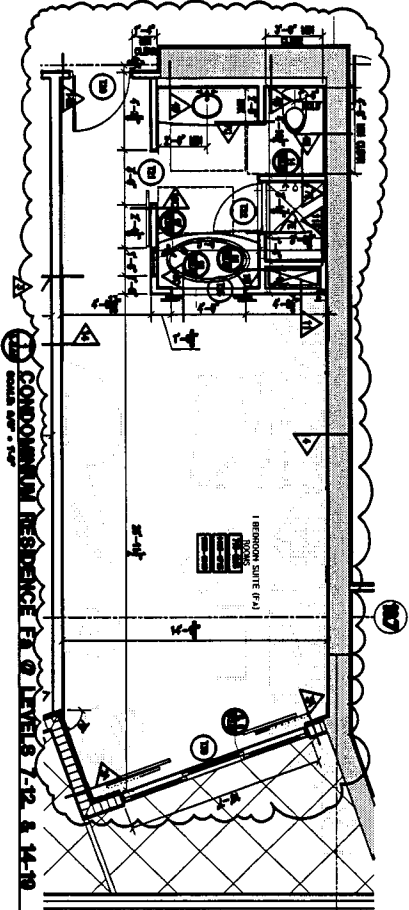

NOTE: - DENOTES REINFORCING BARS

ALL DWELLING UNITS MUST CONTAIN REINFORCEMENT ACCORDING TO THE TABLE AND SHOWN IN THE REINFORCING DETAIL SHEETS. THE REINFORCEMENT SHALL BE INSTALLED IN ALL UNITS ON LATER INSTALLATION OF CONCRETE AND SHALL BE INSTALLED IN ALL UNITS PRIOR TO THE INSTALLATION OF CONCRETE.

FOR TOILET GRAB BAR REINFORCEMENT SEE DETAILS.

FOR SHOWER GRAB BAR AND SEAT REINFORCEMENT SEE DETAILS.

FOR SEAT BELT AND SEAT REINFORCEMENT SEE DETAILS.

FOR SEAT BELT AND SEAT REINFORCEMENT SEE DETAILS.

FOR SEAT BELT AND SEAT REINFORCEMENT SEE DETAILS.

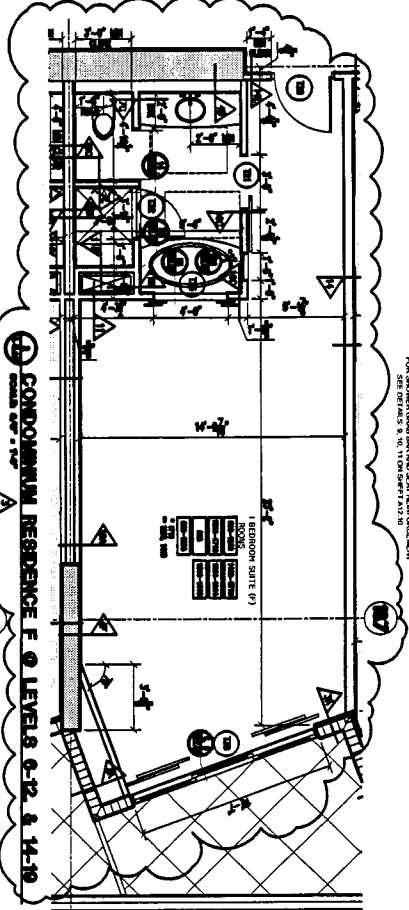

NOTE: - DENOTES REINFORCING BARS

ALL DWELLING UNITS MUST CONTAIN REINFORCEMENT ACCORDING TO THE TABLE AND SHOWN IN THE REINFORCING DETAIL SHEETS. THE REINFORCEMENT SHALL BE INSTALLED IN ALL UNITS ON LATER INSTALLATION OF CONCRETE AND SHALL BE INSTALLED IN ALL UNITS PRIOR TO THE INSTALLATION OF CONCRETE.

FOR TOILET GRAB BAR REINFORCEMENT SEE DETAILS.

FOR SHOWER GRAB BAR AND SEAT REINFORCEMENT SEE DETAILS.

FOR SEAT BELT AND SEAT REINFORCEMENT SEE DETAILS.

FOR SEAT BELT AND SEAT REINFORCEMENT SEE DETAILS.

FOR SEAT BELT AND SEAT REINFORCEMENT SEE DETAILS.

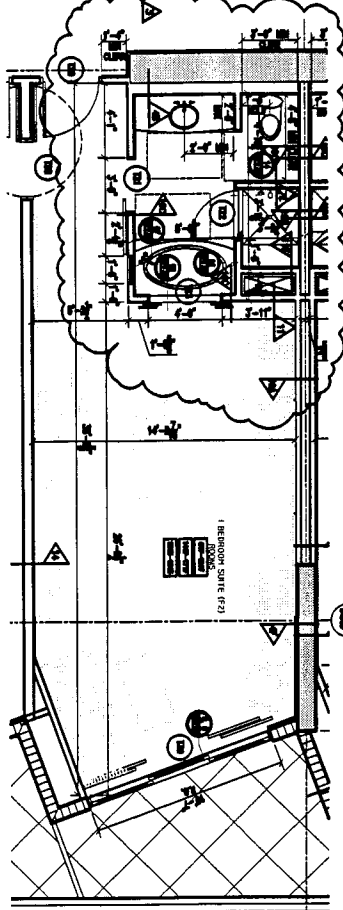

NOTE: - DENOTES REINFORCING BARS

ALL DWELLING UNITS MUST CONTAIN REINFORCEMENT ACCORDING TO THE TABLE AND SHOWN IN THE REINFORCING DETAIL SHEETS. THE REINFORCEMENT SHALL BE INSTALLED IN ALL UNITS ON LATER INSTALLATION OF CONCRETE AND SHALL BE INSTALLED IN ALL UNITS PRIOR TO THE INSTALLATION OF CONCRETE.

FOR TOILET GRAB BAR REINFORCEMENT SEE DETAILS.

FOR SHOWER GRAB BAR AND SEAT REINFORCEMENT SEE DETAILS.

FOR SEAT BELT AND SEAT REINFORCEMENT SEE DETAILS.

FOR SEAT BELT AND SEAT REINFORCEMENT SEE DETAILS.

FOR SEAT BELT AND SEAT REINFORCEMENT SEE DETAILS.

GENERAL NOTES:

1. ALL WORK SHALL BE IN ACCORDANCE WITH THE LATEST EDITIONS OF THE BUILDING CODES AND ALL APPLICABLE LOCAL, STATE AND FEDERAL REGULATIONS.
2. ALL WORK SHALL BE SUBJECT TO THE APPROVAL AND SUPERVISION OF THE LOCAL BUILDING DEPARTMENT.
3. ALL WORK SHALL BE SUBJECT TO THE APPROVAL AND SUPERVISION OF THE LOCAL HEALTH DEPARTMENT.
4. ALL WORK SHALL BE SUBJECT TO THE APPROVAL AND SUPERVISION OF THE LOCAL FIRE DEPARTMENT.

GENERAL NOTES:

1. ALL WORK SHALL BE IN ACCORDANCE WITH THE LATEST EDITIONS OF THE BUILDING CODES AND ALL APPLICABLE LOCAL, STATE AND FEDERAL REGULATIONS.
2. ALL WORK SHALL BE SUBJECT TO THE APPROVAL AND SUPERVISION OF THE LOCAL BUILDING DEPARTMENT.
3. ALL WORK SHALL BE SUBJECT TO THE APPROVAL AND SUPERVISION OF THE LOCAL HEALTH DEPARTMENT.
4. ALL WORK SHALL BE SUBJECT TO THE APPROVAL AND SUPERVISION OF THE LOCAL FIRE DEPARTMENT.

CONDOMINIUM RESIDENCE Q1 @ LEVEL S. 304

NOTE: - DIMENSIONS INCLUDING MARKED

ALL DIMENSIONS UNLESS OTHERWISE SPECIFIED ARE TO FACE UNLESS NOTED OTHERWISE. DIMENSIONS FOR COMMON AREAS AND SHOWN FOR INFORMATION OF OWNER AND TO BE SHOWN ON ALL SETS.

FOR TYPICAL GRID BARS REVISIONS SEE DETAILS.

SEE SHEET S. 307 FOR COMMON AREA REVISIONS.

SEE SHEET S. 308 FOR COMMON AREA REVISIONS.

SEE SHEET S. 309 FOR COMMON AREA REVISIONS.

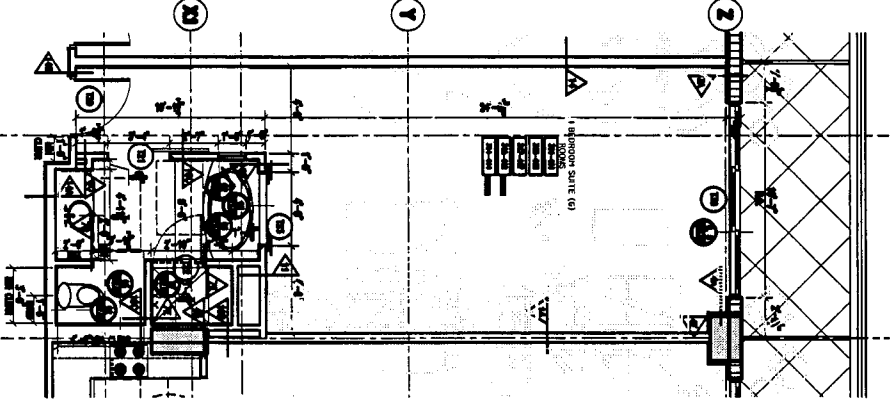

CONDOMINIUM RESIDENCE Q2 @ LEVEL S. 304

NOTE: - DIMENSIONS INCLUDING MARKED

ALL DIMENSIONS UNLESS OTHERWISE SPECIFIED ARE TO FACE UNLESS NOTED OTHERWISE. DIMENSIONS FOR COMMON AREAS AND SHOWN FOR INFORMATION OF OWNER AND TO BE SHOWN ON ALL SETS.

FOR TYPICAL GRID BARS REVISIONS SEE DETAILS.

SEE SHEET S. 307 FOR COMMON AREA REVISIONS.

SEE SHEET S. 308 FOR COMMON AREA REVISIONS.

SEE SHEET S. 309 FOR COMMON AREA REVISIONS.

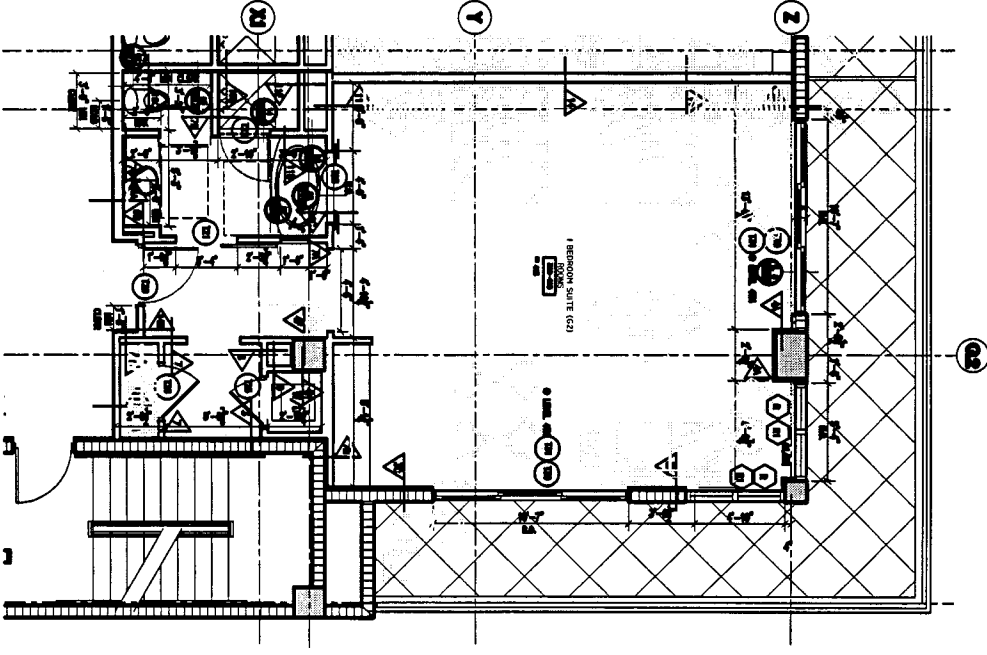

ALL ELEVATION MARKS REFER TO A.G.D.

A-5.06

2/28/08

03-13-2008

NO.	DESCRIPTION	DATE
1	ISSUED FOR PERMIT	03/13/08
2	ISSUED FOR CONSTRUCTION	
3		
4		
5		
6		
7		
8		
9		
10		

Fountainbleau III
OCEAN CLUB
 4391 COLLINS AVENUE, MIAMI BEACH, FL 33146

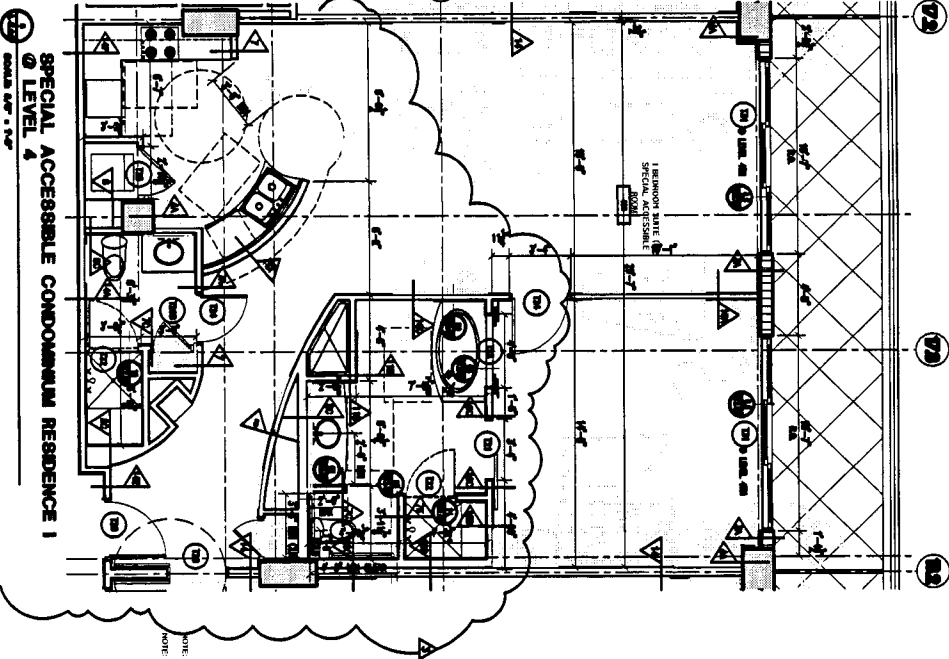
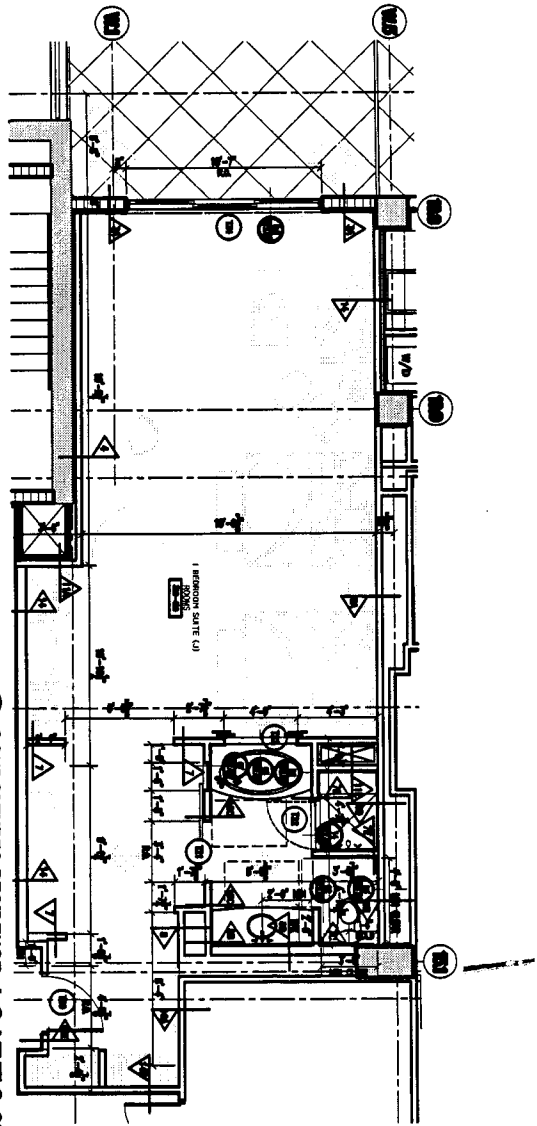

- SPECIAL ACCESSIBLE UNITS:**
1. ADHESIVE FINISHES TO BE APPLIED TO EXPOSED REINFORCEMENT TO BE PROTECTED FROM SALT.
 2. ALL DWELLING UNITS MUST COMPLY WITH REINFORCEMENT AROUND TOILETS, TUBS, AND SHOWERS BY BATHING WALLS TO ALLOW INSTALLATION OF EPOXY ADHESIVE FOR PROTECTIVE FINISHES TO BE APPLIED TO EXPOSED REINFORCEMENT TO BE PROTECTED FROM SALT.
 3. FOR TOILET CASKS BATH REINFORCEMENT SEE DETAILS FOR TOILET CASKS AND SINK REINFORCEMENT FOR SHOWERS, TUBS AND SINK REINFORCEMENT FOR SHOWERS, TUBS AND SINK REINFORCEMENT SEE DETAILS IN 10, 11 ON SHEET A-10, A-11
 4. FOR SHOWERS, TUBS AND SINK REINFORCEMENT SEE DETAILS FOR SHOWERS, TUBS AND SINK REINFORCEMENT FOR SHOWERS, TUBS AND SINK REINFORCEMENT SEE DETAILS IN 10, 11 ON SHEET A-10, A-11
 5. FOR TOILET CASKS BATH REINFORCEMENT SEE DETAILS FOR TOILET CASKS AND SINK REINFORCEMENT FOR SHOWERS, TUBS AND SINK REINFORCEMENT FOR SHOWERS, TUBS AND SINK REINFORCEMENT SEE DETAILS IN 10, 11 ON SHEET A-10, A-11

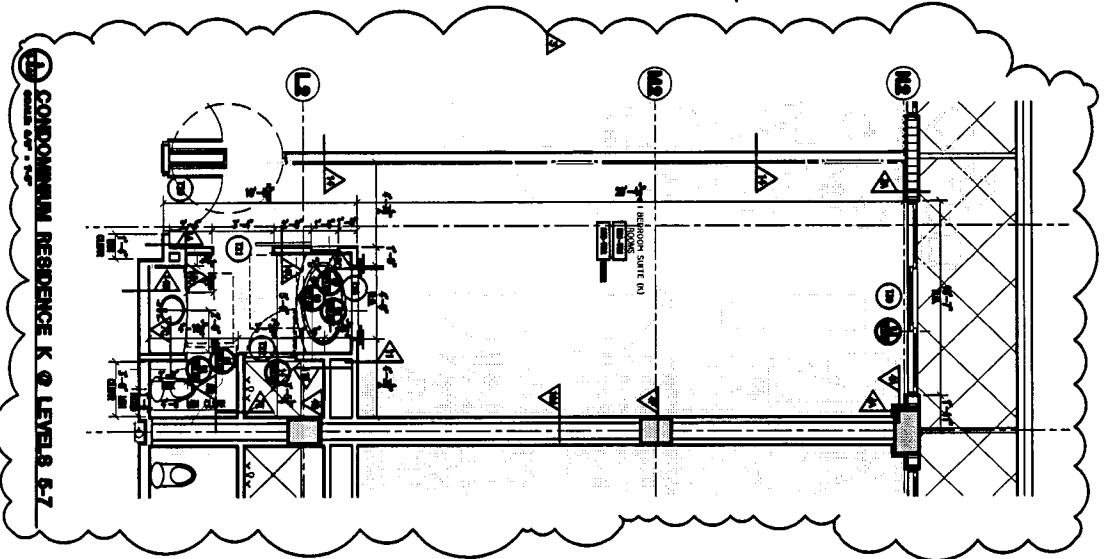

ALL ELEVATION MARKS REFER TO 0.00

A-608

07/12/2005

2285

DATE	DESCRIPTION
07/12/2005	ISSUED FOR PERMIT
07/12/2005	ISSUED FOR PERMIT
07/12/2005	ISSUED FOR PERMIT
07/12/2005	ISSUED FOR PERMIT
07/12/2005	ISSUED FOR PERMIT
07/12/2005	ISSUED FOR PERMIT
07/12/2005	ISSUED FOR PERMIT
07/12/2005	ISSUED FOR PERMIT
07/12/2005	ISSUED FOR PERMIT
07/12/2005	ISSUED FOR PERMIT

Fontainebleau III
OCEAN CLUB

4911 COLLINS AVENUE, MIAMI BEACH, FL 33140



- 1. SEE THE GENERAL REQUIREMENTS FOR THE UNIT, UNIT A.
- 2. ALL DIMENSIONS ARE TO FACE UNLESS OTHERWISE NOTED.
- 3. ALL DIMENSIONS ARE TO FACE UNLESS OTHERWISE NOTED.
- 4. ALL DIMENSIONS ARE TO FACE UNLESS OTHERWISE NOTED.
- 5. ALL DIMENSIONS ARE TO FACE UNLESS OTHERWISE NOTED.

- 1. SEE THE GENERAL REQUIREMENTS FOR THE UNIT, UNIT A.
- 2. ALL DIMENSIONS ARE TO FACE UNLESS OTHERWISE NOTED.
- 3. ALL DIMENSIONS ARE TO FACE UNLESS OTHERWISE NOTED.
- 4. ALL DIMENSIONS ARE TO FACE UNLESS OTHERWISE NOTED.
- 5. ALL DIMENSIONS ARE TO FACE UNLESS OTHERWISE NOTED.

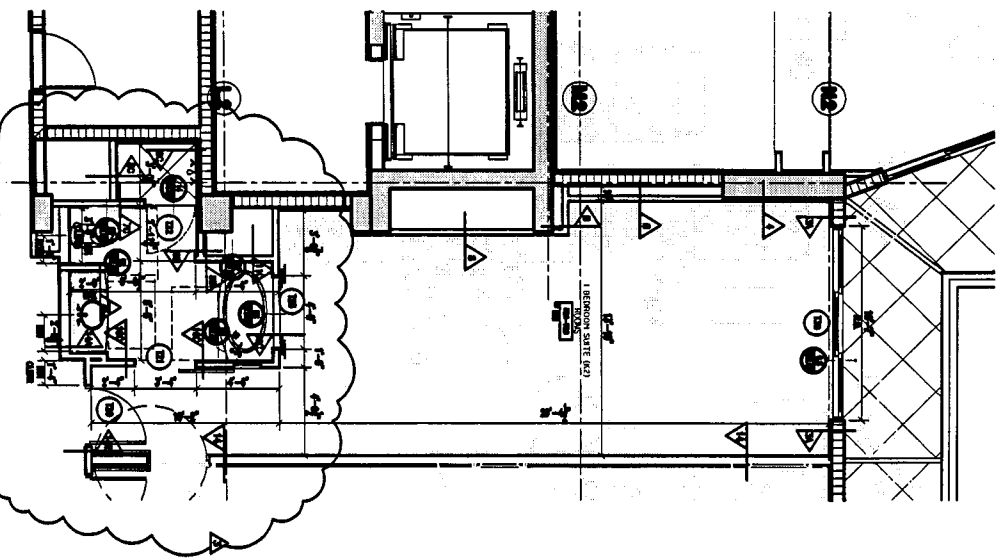

CONDOMINIUM RESIDENCE K2, LEVEL 8, E7
Scale: 1/8" = 1'-0"

NOTE: - DIMENSIONS VARYING IMPROVED
NOTE: ALL DWELLING UNITS MUST CONTAIN THE FOLLOWING IMPROVEMENTS INCLUDING TOILETS, TUBS, AND SHOWERS IN BATHROOM WALLE TO ALLOW INSTALLATION OF GRANITE, TILE OR MARBLE AT FLOOR, ADA WHITE, ADA TOILET SEAT, IMPROVEMENT TO BE MINIMUM 20 GA. STUB.
FOR TOILET GRAB BAR IMPROVEMENT SEE DETAILS
SEE DETAILS 8, 9, 10, 11 ON SHEET A1.10

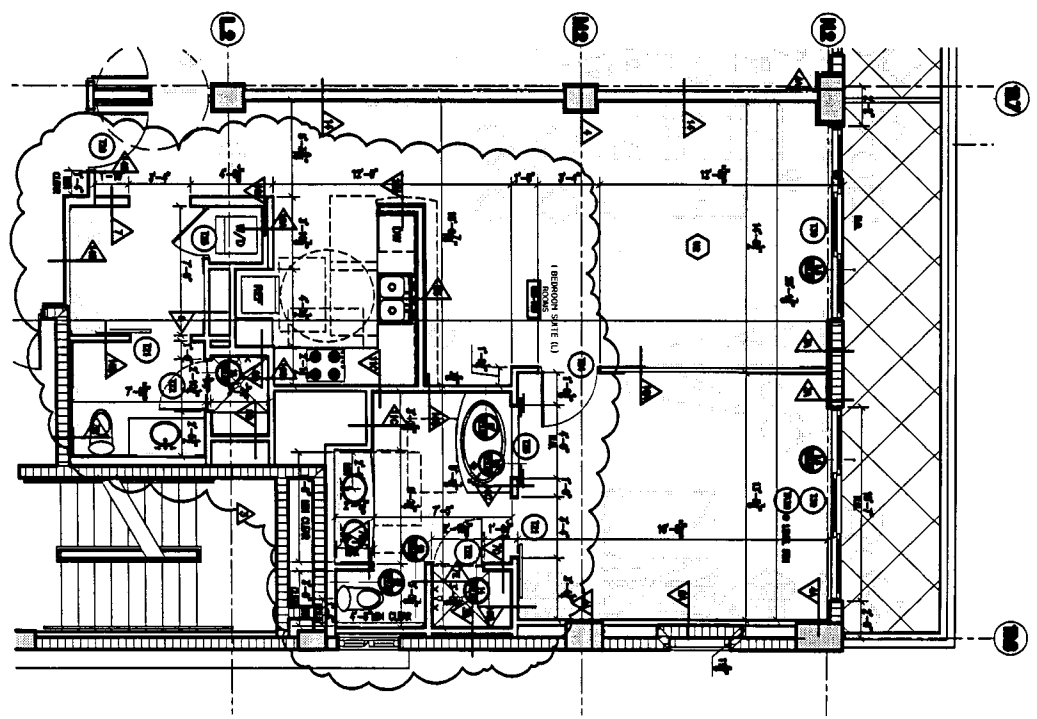

CONDOMINIUM RESIDENCE L1, LEVEL 8, E7
Scale: 1/8" = 1'-0"

NOTE: - DIMENSIONS VARYING IMPROVED
NOTE: ALL DWELLING UNITS MUST CONTAIN THE FOLLOWING IMPROVEMENTS INCLUDING TOILETS, TUBS, AND SHOWERS IN BATHROOM WALLE TO ALLOW INSTALLATION OF GRANITE, TILE OR MARBLE AT FLOOR, ADA WHITE, ADA TOILET SEAT, IMPROVEMENT TO BE MINIMUM 20 GA. STUB.
FOR TOILET GRAB BAR IMPROVEMENT SEE DETAILS
SEE DETAILS 8, 9, 10, 11 ON SHEET A1.10

ALL ELEVATION MARKS REFER TO N.G.M.D.

A-5.09
07-12-2005
2295

NO. 1	DATE	DESCRIPTION

Fontainebleau III
OCEAN CLUB
4911 COLLINS AVENUE, MIAMI BEACH, FL 33149



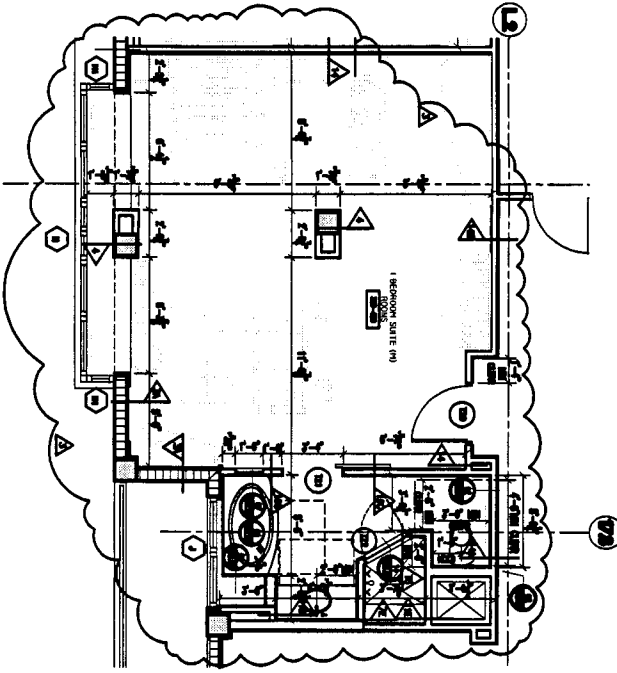

CONDOMINIUM RESIDENCE N-Q LEVELS 3-4
SECTION 1 OF 1

NOTE: - (DEWITT'S MARKING APPLIED)
ALL DIMENSIONS SHOWN ARE TO FACE UNLESS NOTED OTHERWISE.
ALL DIMENSIONS IN BRACKETED WALLS TO ALLOW INSTALLATION OF GIRDERS, THE
SHOWERS SET FOR NON-ADJACENT AREA TO RECEIVE REINFORCEMENT
TO BE INSTALLED ON G.I.A. STUD.
FOR 100 FT GIRDERS REINFORCEMENT SEE DETAILS:
FROM THE GROUND BURN AND SCENT REINFORCEMENT
FOR 100 FT GROUND BURN AND SCENT REINFORCEMENT
SEE DETAILS S. 10, 11 ON SHEET A12.10

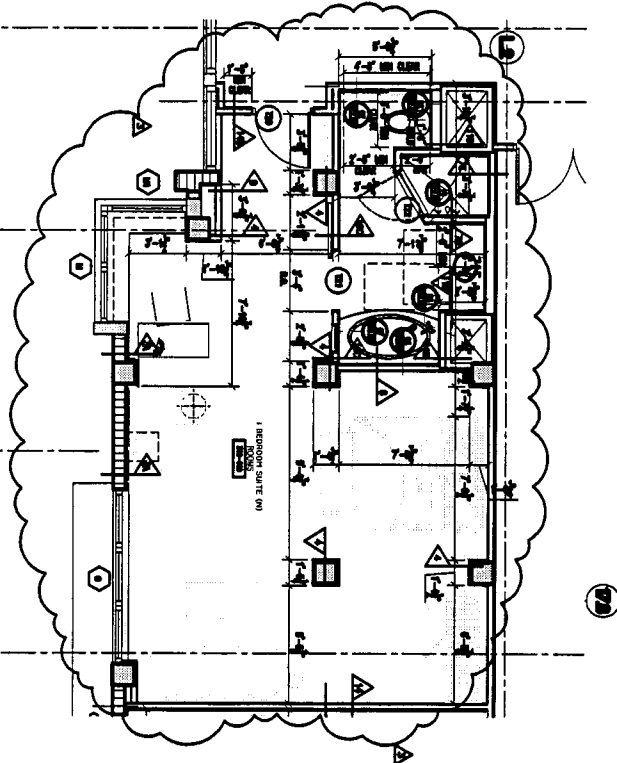

CONDOMINIUM RESIDENCE N-Q LEVELS 3-4
SECTION 2 OF 1

NOTE: - (DEWITT'S MARKING APPLIED)
ALL DIMENSIONS SHOWN ARE TO FACE UNLESS NOTED OTHERWISE.
ALL DIMENSIONS IN BRACKETED WALLS TO ALLOW INSTALLATION OF GIRDERS, THE
SHOWERS SET FOR NON-ADJACENT AREA TO RECEIVE REINFORCEMENT
TO BE INSTALLED ON G.I.A. STUD.
FOR 100 FT GIRDERS REINFORCEMENT SEE DETAILS:
FROM THE GROUND BURN AND SCENT REINFORCEMENT
FOR 100 FT GROUND BURN AND SCENT REINFORCEMENT
SEE DETAILS S. 10, 11 ON SHEET A12.10

- GENERAL NOTES:**
1. REFER TO THE GENERAL NOTES ON SHEET A12.10 FOR THE GROUND BURN AND SCENT REINFORCEMENT DETAILS.
 2. ALL DIMENSIONS SHOWN ARE TO FACE UNLESS NOTED OTHERWISE.
 3. ALL DIMENSIONS IN BRACKETED WALLS TO ALLOW INSTALLATION OF GIRDERS, THE SHOWERS SET FOR NON-ADJACENT AREA TO RECEIVE REINFORCEMENT TO BE INSTALLED ON G.I.A. STUD.
 4. FOR 100 FT GIRDERS REINFORCEMENT SEE DETAILS: FROM THE GROUND BURN AND SCENT REINFORCEMENT FOR 100 FT GROUND BURN AND SCENT REINFORCEMENT SEE DETAILS S. 10, 11 ON SHEET A12.10.
- GENERAL NOTES:**
1. REFER TO THE GENERAL NOTES ON SHEET A12.10 FOR THE GROUND BURN AND SCENT REINFORCEMENT DETAILS.
 2. ALL DIMENSIONS SHOWN ARE TO FACE UNLESS NOTED OTHERWISE.
 3. ALL DIMENSIONS IN BRACKETED WALLS TO ALLOW INSTALLATION OF GIRDERS, THE SHOWERS SET FOR NON-ADJACENT AREA TO RECEIVE REINFORCEMENT TO BE INSTALLED ON G.I.A. STUD.
 4. FOR 100 FT GIRDERS REINFORCEMENT SEE DETAILS: FROM THE GROUND BURN AND SCENT REINFORCEMENT FOR 100 FT GROUND BURN AND SCENT REINFORCEMENT SEE DETAILS S. 10, 11 ON SHEET A12.10.

ALL ELEVATION MARKS REFER TO N.B.V.2

PROJECT NO.	01-23-2005
DATE	2/20/05
SCALE	A-5.10

NO.	DATE	DESCRIPTION
1		ISSUED FOR PERMIT
2		ISSUED FOR CONSTRUCTION
3		ISSUED FOR RECORD

Fontainebleau III
OCEAN CLUB

4391 COLLINS AVENUE, MIAMI BEACH, FL 33140

NOVUS
ARCHITECTS
1000 WEST
WALKER
AVENUE
SUITE 100
MIAMI BEACH, FL 33139
TEL: (305) 673-3333
WWW.NOVUSARCHITECTS.COM

1. ALL DIMENSIONS ARE TO FACE UNLESS NOTED OTHERWISE.
2. ALL FINISHES ARE TO BE AS SHOWN ON THE FINISH SCHEDULE.
3. ALL WALLS ARE TO BE 1/2" THICK UNLESS NOTED OTHERWISE.
4. ALL FLOORS ARE TO BE 1/2" THICK UNLESS NOTED OTHERWISE.
5. ALL CEILING ARE TO BE 1/2" THICK UNLESS NOTED OTHERWISE.
6. ALL DOORS ARE TO BE 1/2" THICK UNLESS NOTED OTHERWISE.
7. ALL WINDOWS ARE TO BE 1/2" THICK UNLESS NOTED OTHERWISE.
8. ALL STAIRS ARE TO BE 1/2" THICK UNLESS NOTED OTHERWISE.
9. ALL ELEVATIONS ARE TO FACE UNLESS NOTED OTHERWISE.
10. ALL FINISHES ARE TO BE AS SHOWN ON THE FINISH SCHEDULE.
11. ALL WALLS ARE TO BE 1/2" THICK UNLESS NOTED OTHERWISE.
12. ALL FLOORS ARE TO BE 1/2" THICK UNLESS NOTED OTHERWISE.
13. ALL CEILING ARE TO BE 1/2" THICK UNLESS NOTED OTHERWISE.
14. ALL DOORS ARE TO BE 1/2" THICK UNLESS NOTED OTHERWISE.
15. ALL WINDOWS ARE TO BE 1/2" THICK UNLESS NOTED OTHERWISE.
16. ALL STAIRS ARE TO BE 1/2" THICK UNLESS NOTED OTHERWISE.
17. ALL ELEVATIONS ARE TO FACE UNLESS NOTED OTHERWISE.
18. ALL FINISHES ARE TO BE AS SHOWN ON THE FINISH SCHEDULE.
19. ALL WALLS ARE TO BE 1/2" THICK UNLESS NOTED OTHERWISE.
20. ALL FLOORS ARE TO BE 1/2" THICK UNLESS NOTED OTHERWISE.
21. ALL CEILING ARE TO BE 1/2" THICK UNLESS NOTED OTHERWISE.
22. ALL DOORS ARE TO BE 1/2" THICK UNLESS NOTED OTHERWISE.
23. ALL WINDOWS ARE TO BE 1/2" THICK UNLESS NOTED OTHERWISE.
24. ALL STAIRS ARE TO BE 1/2" THICK UNLESS NOTED OTHERWISE.
25. ALL ELEVATIONS ARE TO FACE UNLESS NOTED OTHERWISE.

ADA CONDOMINIUM RESIDENCE A WITH ROLL-IN SHOWER LEVEL 10

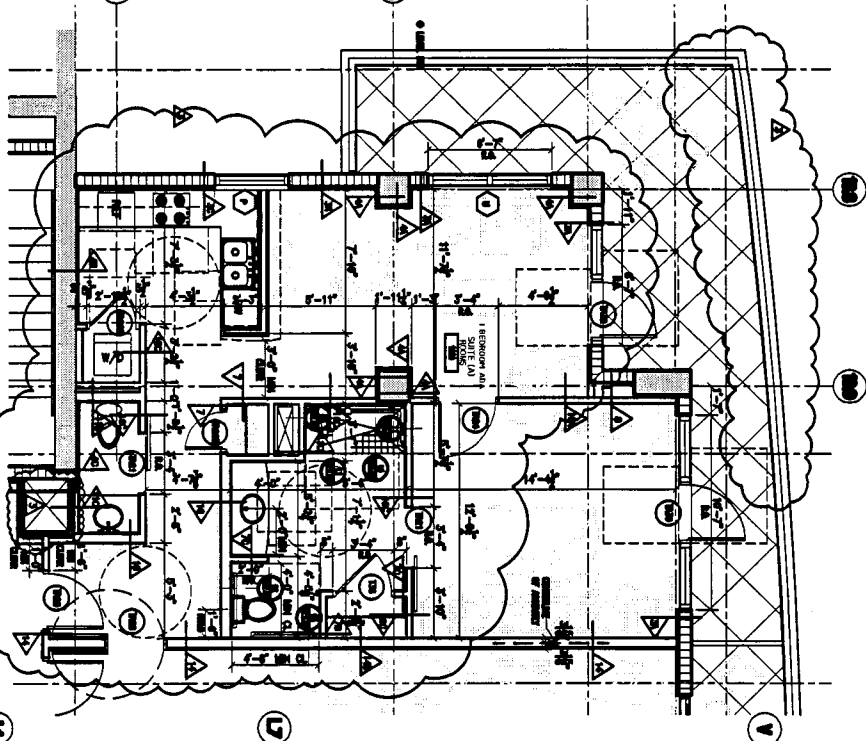

REVISIONS:

NO.	DATE	DESCRIPTION
1	01/12/2015	ISSUE FOR PERMITS
2	01/12/2015	ISSUE FOR PERMITS
3	01/12/2015	ISSUE FOR PERMITS
4	01/12/2015	ISSUE FOR PERMITS
5	01/12/2015	ISSUE FOR PERMITS
6	01/12/2015	ISSUE FOR PERMITS
7	01/12/2015	ISSUE FOR PERMITS
8	01/12/2015	ISSUE FOR PERMITS
9	01/12/2015	ISSUE FOR PERMITS
10	01/12/2015	ISSUE FOR PERMITS
11	01/12/2015	ISSUE FOR PERMITS
12	01/12/2015	ISSUE FOR PERMITS
13	01/12/2015	ISSUE FOR PERMITS
14	01/12/2015	ISSUE FOR PERMITS
15	01/12/2015	ISSUE FOR PERMITS
16	01/12/2015	ISSUE FOR PERMITS
17	01/12/2015	ISSUE FOR PERMITS
18	01/12/2015	ISSUE FOR PERMITS
19	01/12/2015	ISSUE FOR PERMITS
20	01/12/2015	ISSUE FOR PERMITS
21	01/12/2015	ISSUE FOR PERMITS
22	01/12/2015	ISSUE FOR PERMITS
23	01/12/2015	ISSUE FOR PERMITS
24	01/12/2015	ISSUE FOR PERMITS
25	01/12/2015	ISSUE FOR PERMITS

ADA CONDOMINIUM RESIDENCE D @ LEVEL 8

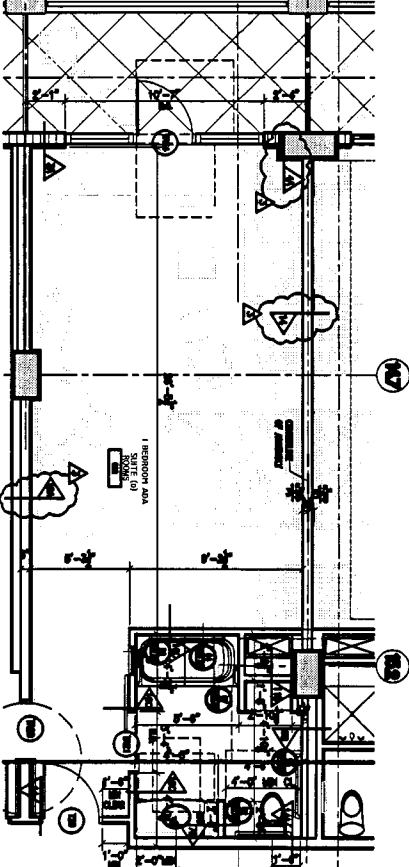

ADA CONDOMINIUM RESIDENCE D @ LEVEL 15

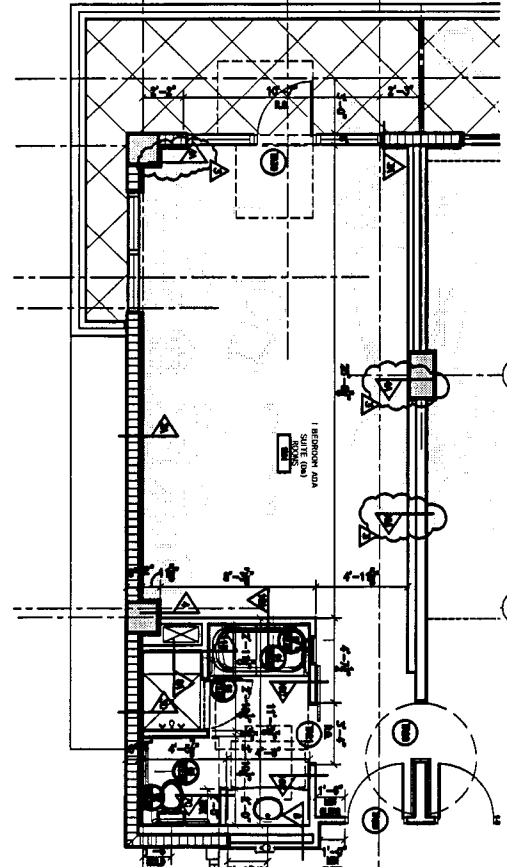

ALL ELEVATION MARKS REFER TO 0.00 V.D.

A-611

NO.	DATE	DESCRIPTION
1	01/12/2015	ISSUE FOR PERMITS
2	01/12/2015	ISSUE FOR PERMITS
3	01/12/2015	ISSUE FOR PERMITS
4	01/12/2015	ISSUE FOR PERMITS
5	01/12/2015	ISSUE FOR PERMITS
6	01/12/2015	ISSUE FOR PERMITS
7	01/12/2015	ISSUE FOR PERMITS
8	01/12/2015	ISSUE FOR PERMITS
9	01/12/2015	ISSUE FOR PERMITS
10	01/12/2015	ISSUE FOR PERMITS
11	01/12/2015	ISSUE FOR PERMITS
12	01/12/2015	ISSUE FOR PERMITS
13	01/12/2015	ISSUE FOR PERMITS
14	01/12/2015	ISSUE FOR PERMITS
15	01/12/2015	ISSUE FOR PERMITS
16	01/12/2015	ISSUE FOR PERMITS
17	01/12/2015	ISSUE FOR PERMITS
18	01/12/2015	ISSUE FOR PERMITS
19	01/12/2015	ISSUE FOR PERMITS
20	01/12/2015	ISSUE FOR PERMITS
21	01/12/2015	ISSUE FOR PERMITS
22	01/12/2015	ISSUE FOR PERMITS
23	01/12/2015	ISSUE FOR PERMITS
24	01/12/2015	ISSUE FOR PERMITS
25	01/12/2015	ISSUE FOR PERMITS

Fontainebleau III
OCEAN CLUB
4391 COLLINS AVENUE, MIAMI BEACH, FL 33140



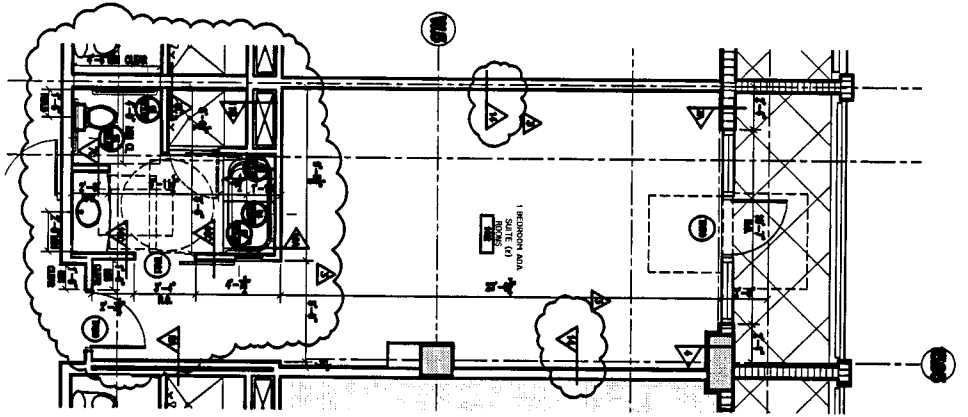
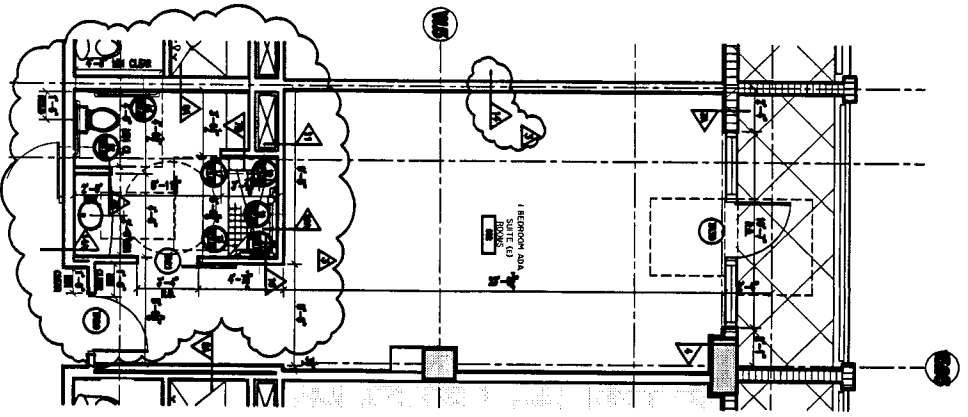
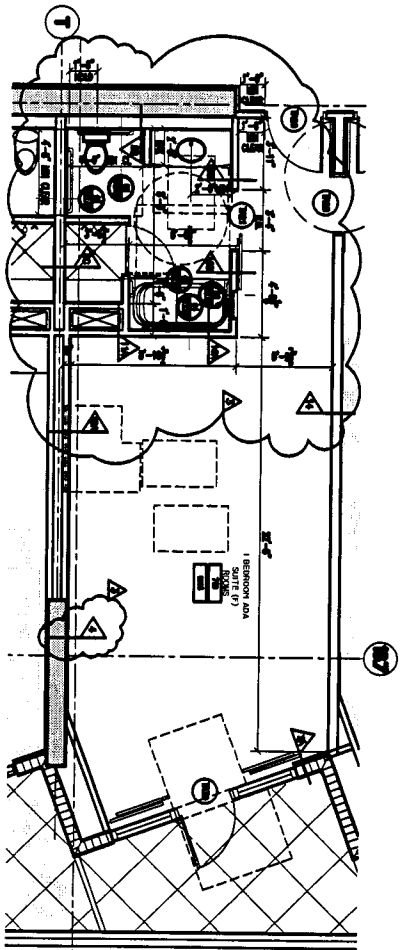

ADA CONDOMINIUM RESIDENCE F @ LEVEL 7 & 8

SCALE 1/8\"/>

NOTE: -- DENOTES REINFORCEMENT

ALL DWELLING UNITS MUST CONTAIN REINFORCEMENT AROUND TOILETS, TUBS, AND SHOWERS. REINFORCEMENT WALLS TO ALLOW INSTALLATION OF GRAB BARS, TUB SHOWER SEAT FOR NON-ADULTS, AREA TO RECEIVE REINFORCEMENT TO BE SHOWN ON OA STUD.

FOR TUB, TOILET, AND SHOWER REINFORCEMENT SEE DETAILS FOR TUB, TOILET, AND SHOWER REINFORCEMENT AND SEAT REINFORCEMENT FROM SHOWER CURTAIN BAR AND SEAT REINFORCEMENT SEE DETAILS IN 1101 SHEET A12.0

ADA CONDOMINIUM RESIDENCE E @ LEVEL 9

SCALE 1/8\"/>

NOTE: -- DENOTES REINFORCEMENT

ALL DWELLING UNITS MUST CONTAIN REINFORCEMENT AROUND TOILETS, TUBS, AND SHOWERS. REINFORCEMENT WALLS TO ALLOW INSTALLATION OF GRAB BARS, TUB SHOWER SEAT FOR NON-ADULTS, AREA TO RECEIVE REINFORCEMENT TO BE SHOWN ON OA STUD.

FOR TUB, TOILET, AND SHOWER REINFORCEMENT SEE DETAILS FOR TUB, TOILET, AND SHOWER REINFORCEMENT AND SEAT REINFORCEMENT FROM SHOWER CURTAIN BAR AND SEAT REINFORCEMENT SEE DETAILS IN 1101 SHEET A12.0

ADA CONDOMINIUM RESIDENCE E @ LEVEL 10

SCALE 1/8\"/>

NOTE: -- DENOTES REINFORCEMENT

ALL DWELLING UNITS MUST CONTAIN REINFORCEMENT AROUND TOILETS, TUBS, AND SHOWERS. REINFORCEMENT WALLS TO ALLOW INSTALLATION OF GRAB BARS, TUB SHOWER SEAT FOR NON-ADULTS, AREA TO RECEIVE REINFORCEMENT TO BE SHOWN ON OA STUD.

FOR TUB, TOILET, AND SHOWER REINFORCEMENT SEE DETAILS FOR TUB, TOILET, AND SHOWER REINFORCEMENT AND SEAT REINFORCEMENT FROM SHOWER CURTAIN BAR AND SEAT REINFORCEMENT SEE DETAILS IN 1101 SHEET A12.0

1. GENERAL NOTES: SEE ALL OTHER SHEETS FOR GENERAL NOTES AND SPECIFICATIONS.
2. ALL DIMENSIONS UNLESS OTHERWISE NOTED ARE TO FACE UNLESS INDICATED OTHERWISE.
3. FINISHES: SEE FINISH SCHEDULE FOR FINISHES TO BE USED IN THIS AREA.
4. MATERIALS: ALL MATERIALS SHALL BE OF THE HIGHEST QUALITY AVAILABLE AND SHALL BE SUBJECT TO APPROVAL BY THE ARCHITECT.
5. INSTALLATION: ALL INSTALLATION SHALL BE IN ACCORDANCE WITH THE MANUFACTURER'S INSTRUCTIONS AND SHALL BE SUBJECT TO APPROVAL BY THE ARCHITECT.
6. PROTECTION: ALL AREAS TO BE PROTECTED SHALL BE PROTECTED PRIOR TO THE START OF WORK AND SHALL REMAIN PROTECTED THROUGHOUT THE PROJECT.
7. CLEANUP: ALL DEBRIS SHALL BE REMOVED FROM THE SITE AT THE END OF EACH DAY AND AT THE END OF THE PROJECT.
8. SAFETY: ALL WORK SHALL BE PERFORMED IN ACCORDANCE WITH ALL APPLICABLE SAFETY REGULATIONS AND SHALL BE SUBJECT TO APPROVAL BY THE ARCHITECT.
9. ACCESSIBILITY: ALL AREAS SHALL BE ACCESSIBLE TO ALL USERS, INCLUDING BUT NOT LIMITED TO THE HANDICAPPED.
10. COMPLIANCE: ALL WORK SHALL BE IN ACCORDANCE WITH ALL APPLICABLE CODES AND REGULATIONS, INCLUDING BUT NOT LIMITED TO THE ADA.

A-6-12
10-12-2006
2285

Fontainebleau III
OCEAN CLUB
4791 COLLINS AVENUE, MIAMI BEACH, FL 33146

NO COPY
NO COPY
NO COPY
NO COPY
NO COPY

- 1. INTERIOR FINISHES TO BE 1/2" X 6" X 1/2" GYPSUM BOARD OVER STUDS AND JOISTS.
- 2. INTERIOR PARTITIONS TO BE 5/8" X 1/2" X 1/2" GYPSUM BOARD OVER STUDS AND JOISTS.
- 3. INTERIOR PARTITIONS TO BE 1/2" X 6" X 1/2" GYPSUM BOARD OVER STUDS AND JOISTS.
- 4. INTERIOR PARTITIONS TO BE 1/2" X 6" X 1/2" GYPSUM BOARD OVER STUDS AND JOISTS.
- 5. INTERIOR PARTITIONS TO BE 1/2" X 6" X 1/2" GYPSUM BOARD OVER STUDS AND JOISTS.
- 6. INTERIOR PARTITIONS TO BE 1/2" X 6" X 1/2" GYPSUM BOARD OVER STUDS AND JOISTS.
- 7. INTERIOR PARTITIONS TO BE 1/2" X 6" X 1/2" GYPSUM BOARD OVER STUDS AND JOISTS.
- 8. INTERIOR PARTITIONS TO BE 1/2" X 6" X 1/2" GYPSUM BOARD OVER STUDS AND JOISTS.
- 9. INTERIOR PARTITIONS TO BE 1/2" X 6" X 1/2" GYPSUM BOARD OVER STUDS AND JOISTS.
- 10. INTERIOR PARTITIONS TO BE 1/2" X 6" X 1/2" GYPSUM BOARD OVER STUDS AND JOISTS.

ADA CONDOMINIUM RESIDENCE Q WITH ROLL-IN SHOWER @ LEVEL 3

NOTE: ALL DIMENSIONS UNLESS OTHERWISE NOTED. FINISHES AND SHOWERS IN THIS RESIDENCE TO ALLOW INSTALLATION OF CURTAIN RODS TO BE MINIMUM 20" O.A. SHD.

FOR TANK ET GRAB BAR REQUIREMENT SEE DETAILS. SEE DETAILS S, K, L, A, R, W, AND S, T, U FOR FINISHES, S, R, T, U ON SHEET A13.9

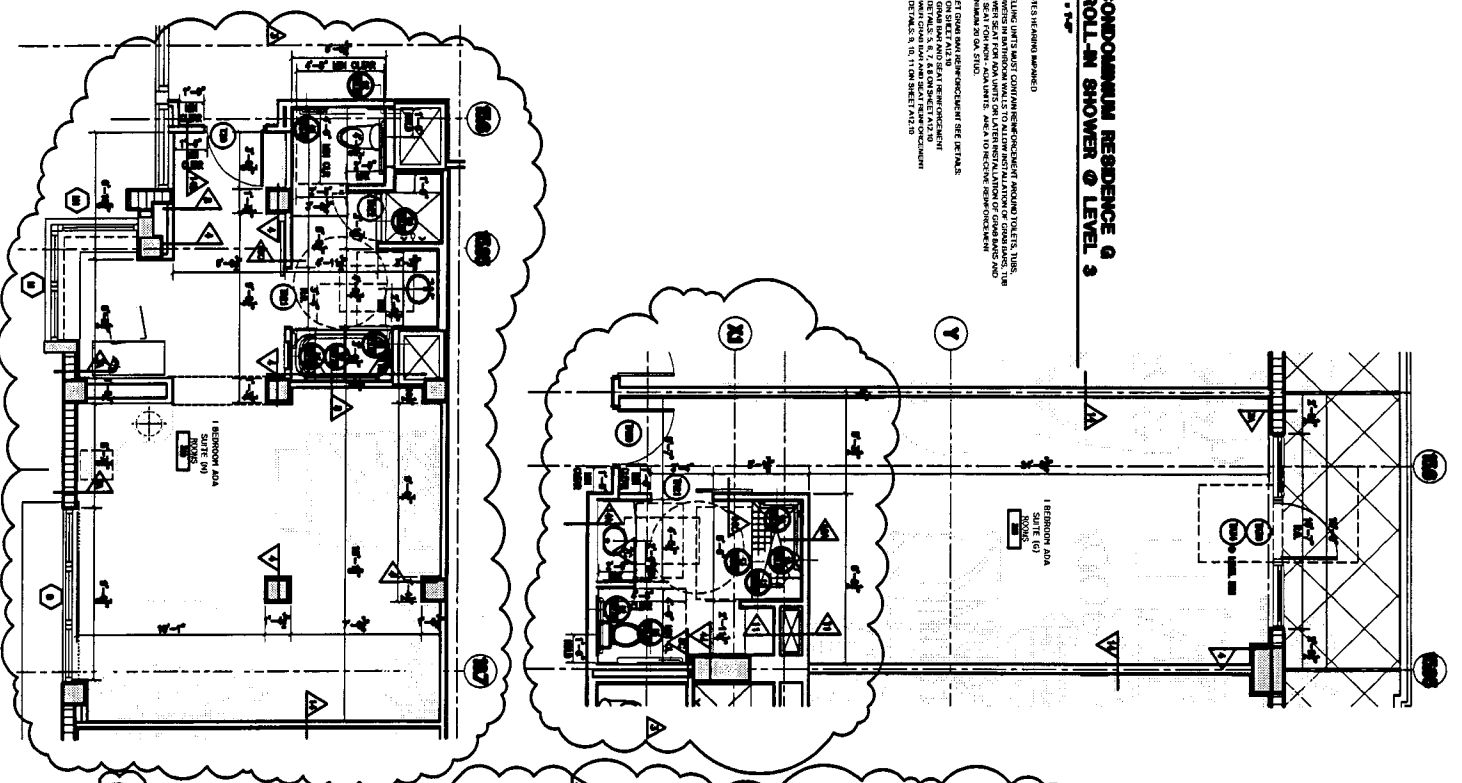

ADA CONDOMINIUM RESIDENCE L @ LEVEL 05

NOTE: ALL DIMENSIONS UNLESS OTHERWISE NOTED. FINISHES AND SHOWERS IN THIS RESIDENCE TO ALLOW INSTALLATION OF CURTAIN RODS TO BE MINIMUM 20" O.A. SHD.

FOR TANK ET GRAB BAR REQUIREMENT SEE DETAILS. SEE DETAILS S, K, L, A, R, W, AND S, T, U FOR FINISHES, S, R, T, U ON SHEET A13.9

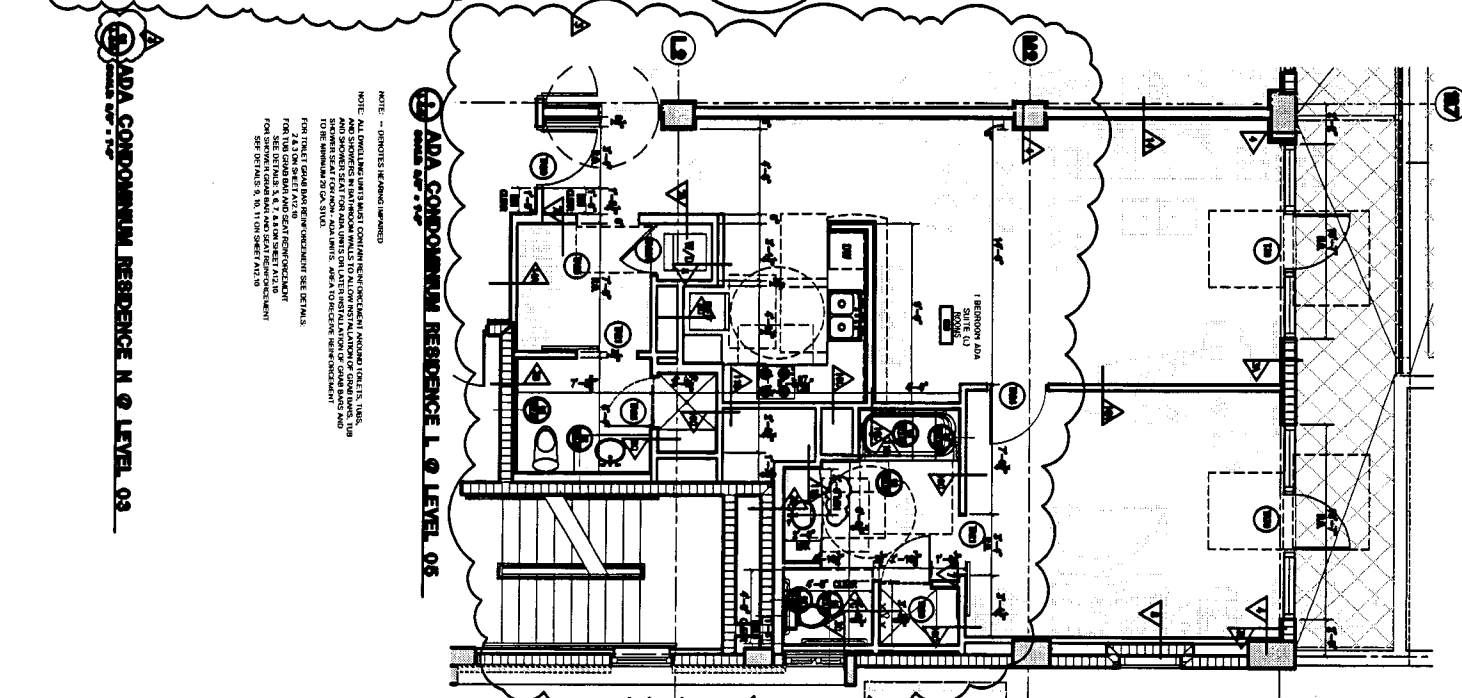

ADA CONDOMINIUM RESIDENCE N @ LEVEL 03

A-519	01.13.2008	2/285
<p>Fontainebleau III OCEAN CLUB</p> <p>4911 COLLINS AVENUE, MIAMI BEACH, FL 33146</p>		
<p>ARCHITECTURAL FIRM</p>		

1. GENERAL NOTES: SEE ALL NOTES ON DRAWINGS.
2. ALL WORK SHALL BE IN ACCORDANCE WITH THE LATEST EDITIONS OF THE INTERNATIONAL BUILDING CODES (IBC) AND ALL APPLICABLE LOCAL, STATE AND FEDERAL CODES.
3. ALL MATERIALS AND METHODS OF CONSTRUCTION SHALL BE APPROVED BY THE ARCHITECT AND SHALL BE IN ACCORDANCE WITH THE SPECIFICATIONS AND NOTES ON DRAWINGS.
4. ALL WORK SHALL BE COMPLETED WITHIN THE SPECIFIED TIME FRAME AND SHALL BE SUBJECT TO INSPECTION AND APPROVAL BY THE ARCHITECT.
5. ALL WORK SHALL BE COMPLETED WITHIN THE SPECIFIED TIME FRAME AND SHALL BE SUBJECT TO INSPECTION AND APPROVAL BY THE ARCHITECT.
6. ALL WORK SHALL BE COMPLETED WITHIN THE SPECIFIED TIME FRAME AND SHALL BE SUBJECT TO INSPECTION AND APPROVAL BY THE ARCHITECT.
7. ALL WORK SHALL BE COMPLETED WITHIN THE SPECIFIED TIME FRAME AND SHALL BE SUBJECT TO INSPECTION AND APPROVAL BY THE ARCHITECT.
8. ALL WORK SHALL BE COMPLETED WITHIN THE SPECIFIED TIME FRAME AND SHALL BE SUBJECT TO INSPECTION AND APPROVAL BY THE ARCHITECT.
9. ALL WORK SHALL BE COMPLETED WITHIN THE SPECIFIED TIME FRAME AND SHALL BE SUBJECT TO INSPECTION AND APPROVAL BY THE ARCHITECT.
10. ALL WORK SHALL BE COMPLETED WITHIN THE SPECIFIED TIME FRAME AND SHALL BE SUBJECT TO INSPECTION AND APPROVAL BY THE ARCHITECT.

1. ENLARGED PLAN OF LEVEL 00: SEE ALL NOTES ON DRAWINGS.
2. ENLARGED PLAN OF LEVEL 01: SEE ALL NOTES ON DRAWINGS.
3. ENLARGED PLAN OF LEVEL 02: SEE ALL NOTES ON DRAWINGS.
4. ENLARGED PLAN OF LEVEL 03: SEE ALL NOTES ON DRAWINGS.
5. ENLARGED PLAN OF LEVEL 04: SEE ALL NOTES ON DRAWINGS.
6. ENLARGED PLAN OF LEVEL 05: SEE ALL NOTES ON DRAWINGS.
7. ENLARGED PLAN OF LEVEL 06: SEE ALL NOTES ON DRAWINGS.
8. ENLARGED PLAN OF LEVEL 07: SEE ALL NOTES ON DRAWINGS.
9. ENLARGED PLAN OF LEVEL 08: SEE ALL NOTES ON DRAWINGS.
10. ENLARGED PLAN OF LEVEL 09: SEE ALL NOTES ON DRAWINGS.

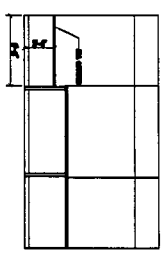

**ELEVATION
RECEPTION DESK @ LEVEL 02**
SCALE: 1/8" = 1'-0"

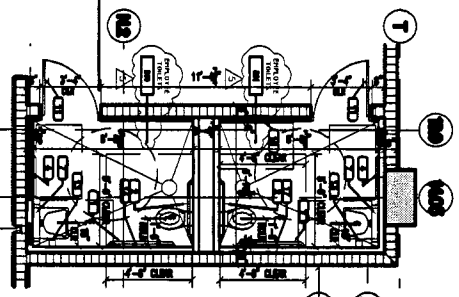

**ENLARGED PLAN
EMPLOYEE BATHROOMS @ LEVEL 00**
SCALE: 1/8" = 1'-0"

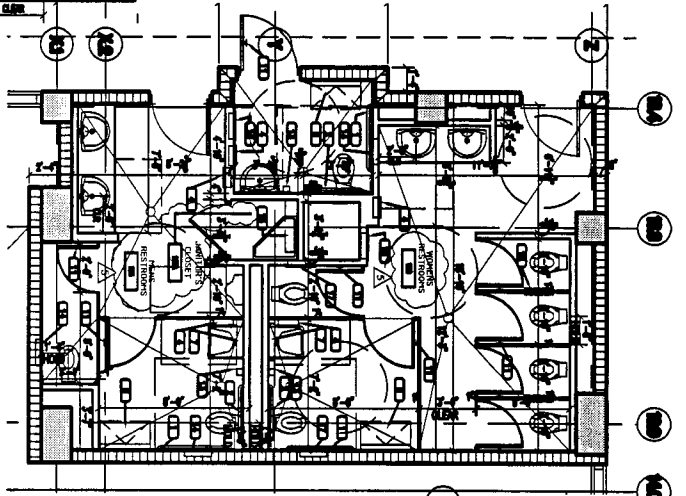

**ENLARGED PLAN
BATHROOMS @ LEVEL 01**
SCALE: 1/8" = 1'-0"

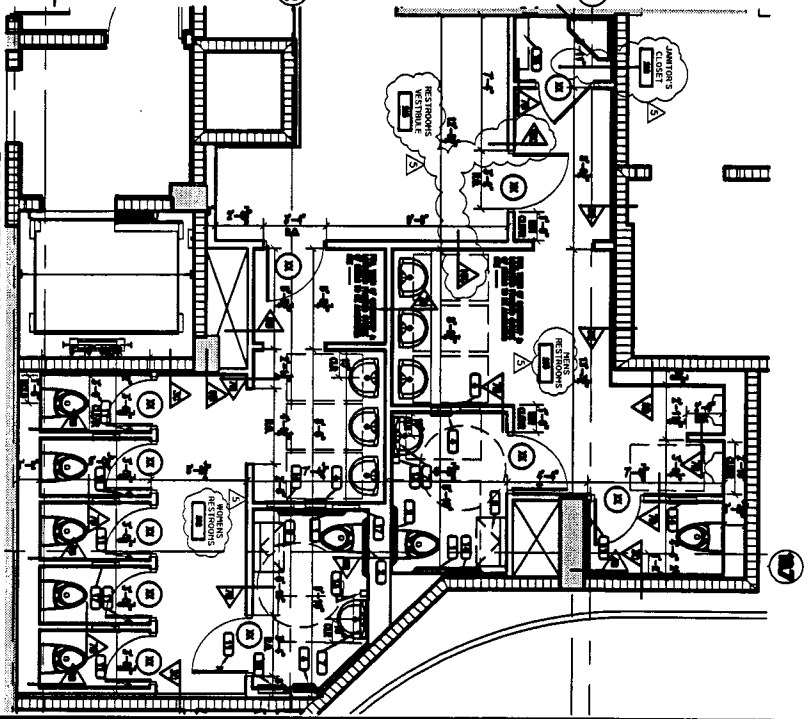

**ENLARGED PLAN
BATHROOMS @ LOBBY LEVEL - 02**
SCALE: 1/8" = 1'-0"

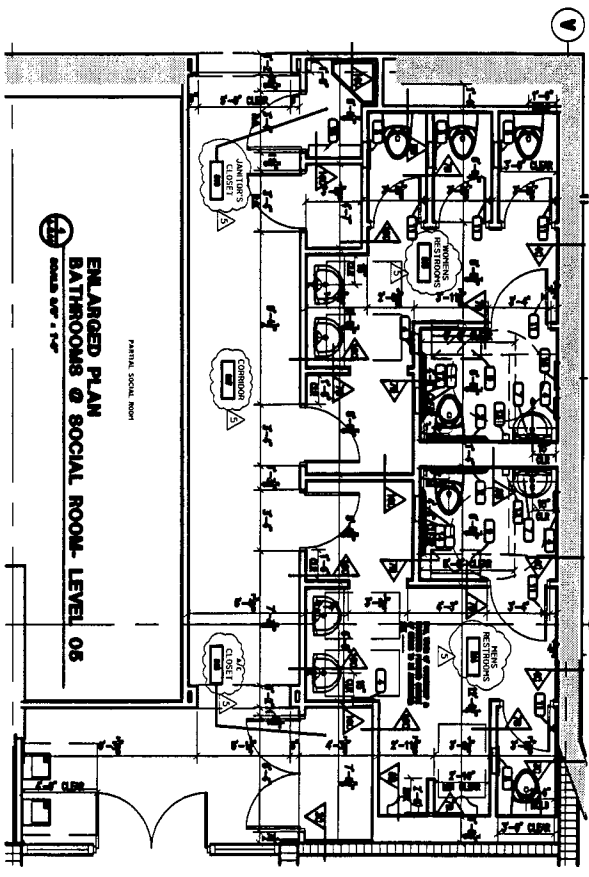

**ENLARGED PLAN
BATHROOMS @ SOCIAL ROOM- LEVEL 05**
SCALE: 1/8" = 1'-0"

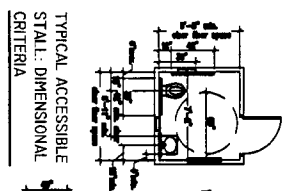

TYPICAL ACCESSIBLE
STALL- DIMENSIONAL
CRITERIA

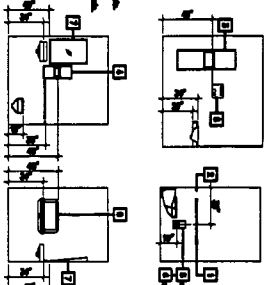

TYPICAL ACCESSIBLE
STALL- ACCESSORIES
MOUNTING LOCATIONS

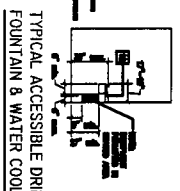

TYPICAL ACCESSIBLE DRINKING
FOUNTAIN & WATER COOLERS.

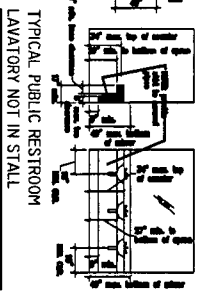

TYPICAL PUBLIC RESTROOM
LAVATORY NOT IN STALL

ALL ELEVATION MARKS REFER TO N.G.D.

DATE: 07-13-2006	PROJECT: 27285
A-6-14	

NO.	DESCRIPTION	DATE
1	ISSUED FOR PERMIT	07-13-2006
2	ISSUED FOR CONSTRUCTION	07-13-2006
3	ISSUED FOR CORRECTIONS	07-13-2006
4	ISSUED FOR AS-BUILT	07-13-2006

Fontainebleau III
OCEAN CLUB
4391 COLLINS AVENUE, MIAMI BEACH, FL 33140



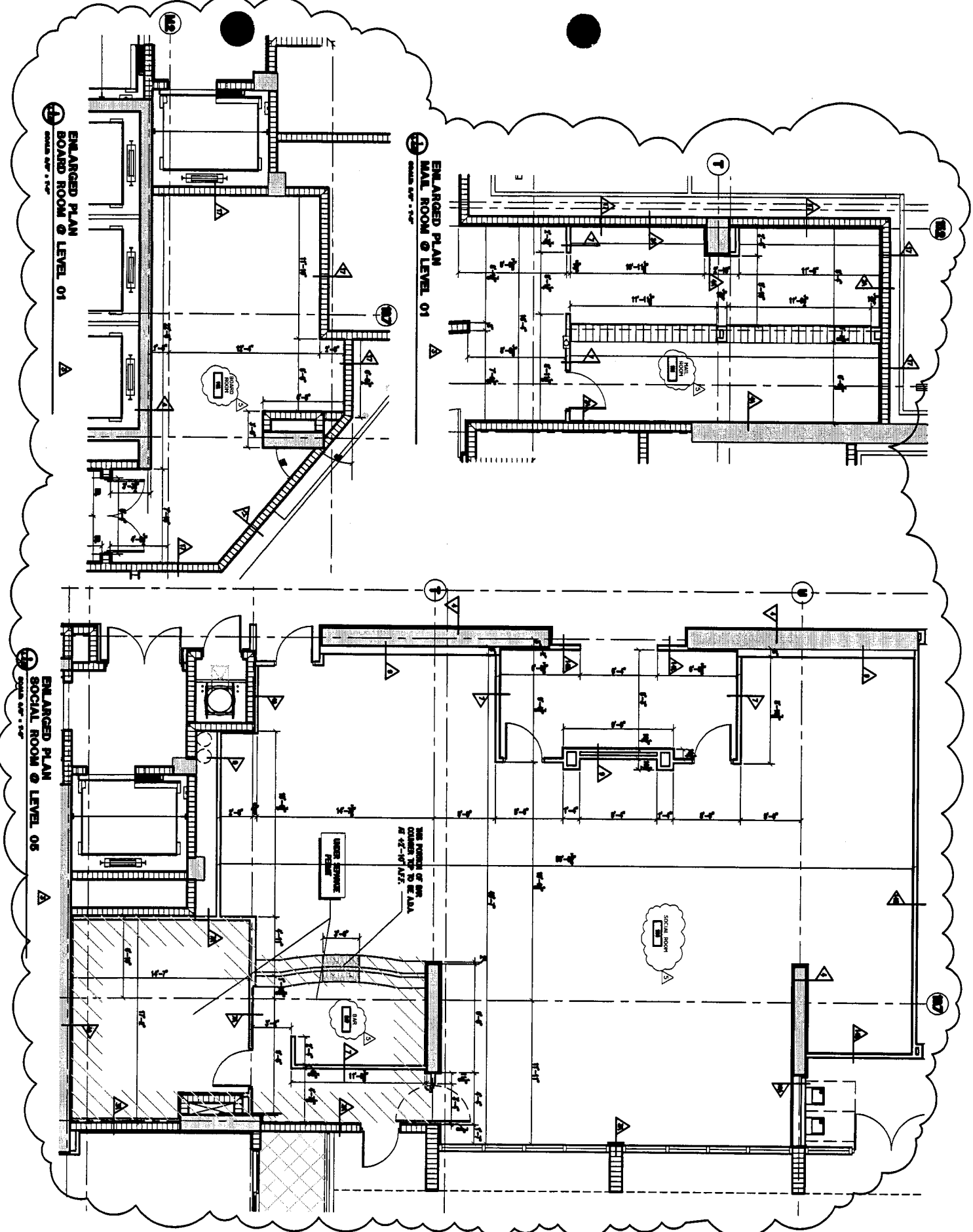

ALL ELEVATION MARKS REFER TO N.G.V.C.

A-5.15
07-13-2005
2705

1	CONCRETE	2	1/2" GYPSUM BOARD
3	1/2" GYPSUM BOARD	4	1/2" GYPSUM BOARD
5	1/2" GYPSUM BOARD	6	1/2" GYPSUM BOARD
7	1/2" GYPSUM BOARD	8	1/2" GYPSUM BOARD
9	1/2" GYPSUM BOARD	10	1/2" GYPSUM BOARD
11	1/2" GYPSUM BOARD	12	1/2" GYPSUM BOARD
13	1/2" GYPSUM BOARD	14	1/2" GYPSUM BOARD
15	1/2" GYPSUM BOARD	16	1/2" GYPSUM BOARD
17	1/2" GYPSUM BOARD	18	1/2" GYPSUM BOARD
19	1/2" GYPSUM BOARD	20	1/2" GYPSUM BOARD
21	1/2" GYPSUM BOARD	22	1/2" GYPSUM BOARD
23	1/2" GYPSUM BOARD	24	1/2" GYPSUM BOARD
25	1/2" GYPSUM BOARD	26	1/2" GYPSUM BOARD
27	1/2" GYPSUM BOARD	28	1/2" GYPSUM BOARD
29	1/2" GYPSUM BOARD	30	1/2" GYPSUM BOARD
31	1/2" GYPSUM BOARD	32	1/2" GYPSUM BOARD
33	1/2" GYPSUM BOARD	34	1/2" GYPSUM BOARD
35	1/2" GYPSUM BOARD	36	1/2" GYPSUM BOARD
37	1/2" GYPSUM BOARD	38	1/2" GYPSUM BOARD
39	1/2" GYPSUM BOARD	40	1/2" GYPSUM BOARD
41	1/2" GYPSUM BOARD	42	1/2" GYPSUM BOARD
43	1/2" GYPSUM BOARD	44	1/2" GYPSUM BOARD
45	1/2" GYPSUM BOARD	46	1/2" GYPSUM BOARD
47	1/2" GYPSUM BOARD	48	1/2" GYPSUM BOARD
49	1/2" GYPSUM BOARD	50	1/2" GYPSUM BOARD
51	1/2" GYPSUM BOARD	52	1/2" GYPSUM BOARD
53	1/2" GYPSUM BOARD	54	1/2" GYPSUM BOARD
55	1/2" GYPSUM BOARD	56	1/2" GYPSUM BOARD
57	1/2" GYPSUM BOARD	58	1/2" GYPSUM BOARD
59	1/2" GYPSUM BOARD	60	1/2" GYPSUM BOARD
61	1/2" GYPSUM BOARD	62	1/2" GYPSUM BOARD
63	1/2" GYPSUM BOARD	64	1/2" GYPSUM BOARD
65	1/2" GYPSUM BOARD	66	1/2" GYPSUM BOARD
67	1/2" GYPSUM BOARD	68	1/2" GYPSUM BOARD
69	1/2" GYPSUM BOARD	70	1/2" GYPSUM BOARD
71	1/2" GYPSUM BOARD	72	1/2" GYPSUM BOARD
73	1/2" GYPSUM BOARD	74	1/2" GYPSUM BOARD
75	1/2" GYPSUM BOARD	76	1/2" GYPSUM BOARD
77	1/2" GYPSUM BOARD	78	1/2" GYPSUM BOARD
79	1/2" GYPSUM BOARD	80	1/2" GYPSUM BOARD
81	1/2" GYPSUM BOARD	82	1/2" GYPSUM BOARD
83	1/2" GYPSUM BOARD	84	1/2" GYPSUM BOARD
85	1/2" GYPSUM BOARD	86	1/2" GYPSUM BOARD
87	1/2" GYPSUM BOARD	88	1/2" GYPSUM BOARD
89	1/2" GYPSUM BOARD	90	1/2" GYPSUM BOARD
91	1/2" GYPSUM BOARD	92	1/2" GYPSUM BOARD
93	1/2" GYPSUM BOARD	94	1/2" GYPSUM BOARD
95	1/2" GYPSUM BOARD	96	1/2" GYPSUM BOARD
97	1/2" GYPSUM BOARD	98	1/2" GYPSUM BOARD
99	1/2" GYPSUM BOARD	100	1/2" GYPSUM BOARD

Fontainebleau III
OCEAN CLUB
4391 COLLINS AVENUE, MIAMI BEACH, FL 33140



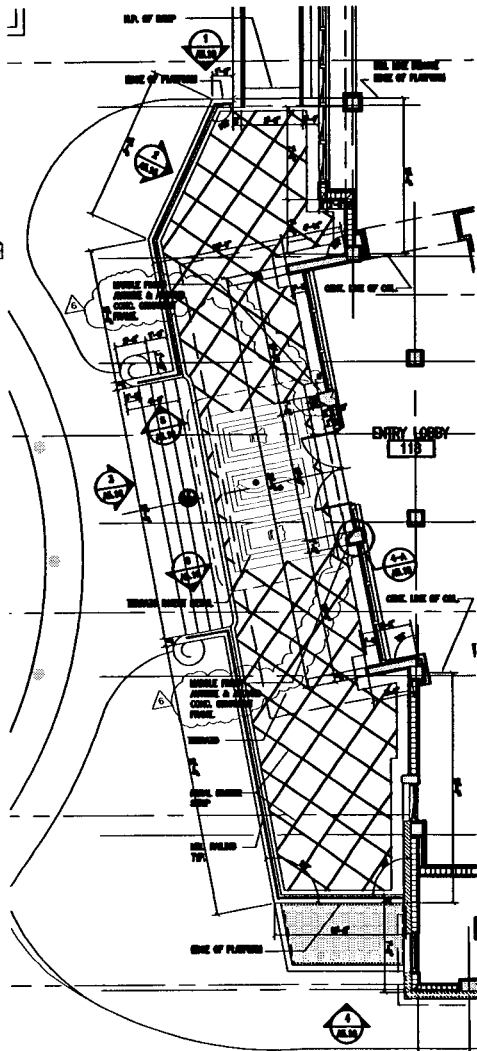

SORRENTO ENTRY TERRAZZO PATTERN DESIGN
SCALE: 1/4" = 1'-0"

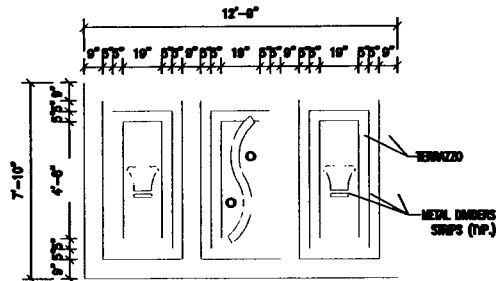

SORRENTO ENTRY TERRAZZO INSERT DETAIL
SCALE: 1/4" = 1'-0"

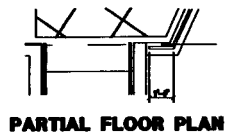

PARTIAL FLOOR PLAN

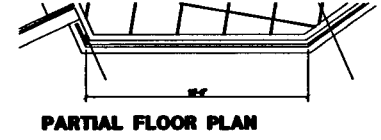

PARTIAL FLOOR PLAN

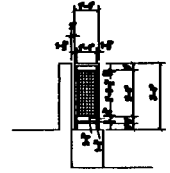

RAILING ELEVATION NO.1

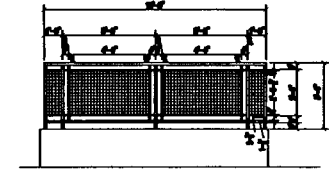

RAILING ELEVATION NO.2

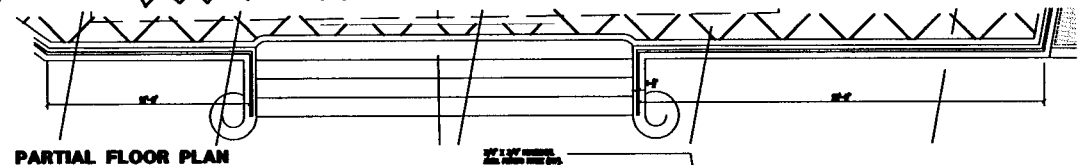

PARTIAL FLOOR PLAN

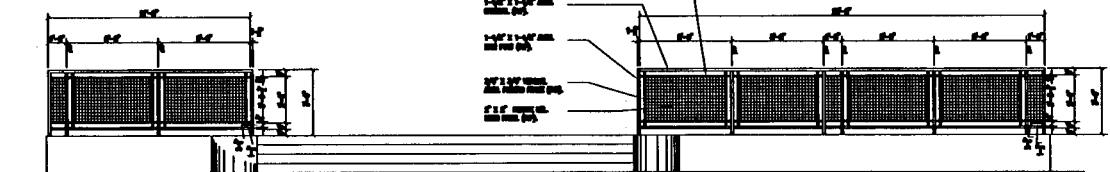

RAILING ELEVATION NO.3

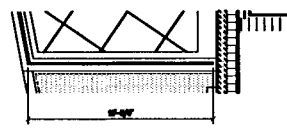

PARTIAL FLOOR PLAN

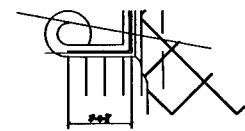

PARTIAL FLOOR PLAN

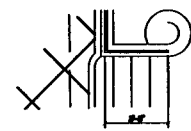

PARTIAL FLOOR PLAN

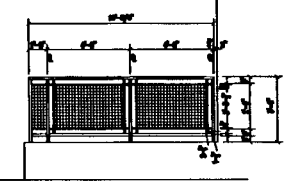

RAILING ELEVATION NO.4

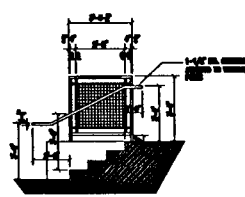

RAILING ELEVATION NO.5

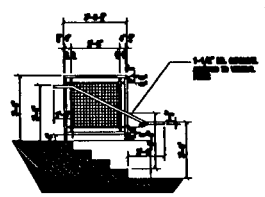

RAILING ELEVATION NO.6

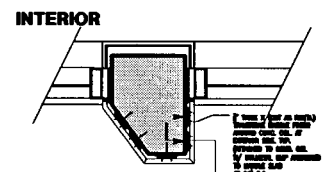

INTERIOR PARTIAL PLAN VIEW

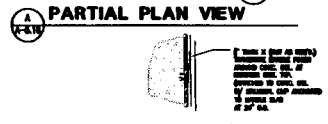

INTERIOR PARTIAL SECTION/DETAIL

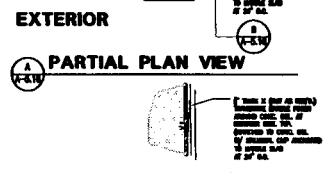

EXTERIOR PARTIAL PLAN VIEW



SORRENTO ENTRY COL. MARBLE DETAIL
SCALE: 1/4" = 1'-0"

NOTE: MATERIALS PROVIDED FOR THIS PROJECT ARE TO BE APPROVED BY ARCHITECT AND BEFORE PROCEEDING OFFICE.

SORRENTO ENTRY RAILING ELEVATIONS
SCALE: 1/4" = 1'-0"

NICHOLS BROSH WOLFE

Fountains III
OCEAN CLUB
401 COLLINS AVENUE, MIAMI BEACH, FL 33140

PERM. CASE: 23040
N.C. DEPT. COMM. IS: 20040
N.C. DEPT. COMM. IS: 20040
N.C. DEPT. COMM. IS: 20040
N.C. DEPT. COMM. IS: 20040
COORDINATION: 20040
CONSTRUCTION: 20040
CONSTRUCTION: 20040
CONSTRUCTION: 20040

07-12-2005
2285
A-5.16

A/C GENERAL NOTES

- 1. GENERAL: ... 2. MATERIALS: ... 3. INSTALLATION: ... 4. MAINTENANCE: ...

- 1. GENERAL: ... 2. MATERIALS: ... 3. INSTALLATION: ... 4. MAINTENANCE: ...

- 1. GENERAL: ... 2. MATERIALS: ... 3. INSTALLATION: ... 4. MAINTENANCE: ...

- 1. GENERAL: ... 2. MATERIALS: ... 3. INSTALLATION: ... 4. MAINTENANCE: ...

- 1. GENERAL: ... 2. MATERIALS: ... 3. INSTALLATION: ... 4. MAINTENANCE: ...

- 1. GENERAL: ... 2. MATERIALS: ... 3. INSTALLATION: ... 4. MAINTENANCE: ...

- 1. GENERAL: ... 2. MATERIALS: ... 3. INSTALLATION: ... 4. MAINTENANCE: ...

- 1. GENERAL: ... 2. MATERIALS: ... 3. INSTALLATION: ... 4. MAINTENANCE: ...

- 1. GENERAL: ... 2. MATERIALS: ... 3. INSTALLATION: ... 4. MAINTENANCE: ...

MECHANICAL INSULATION

AC COMPARTMENT LEGEND

ADDITIONAL NOTES

MECHANICAL SCHEDULE

CHILTRIS SCHEDULE

Table with 10 columns: No., Description, Unit Location, Size, Material, etc. Includes Mechanical Schedule and Chiltris Schedule.

Table with 10 columns: No., Description, Unit Location, Size, Material, etc. Includes Mechanical Schedule and Chiltris Schedule.

Table with 10 columns: No., Description, Unit Location, Size, Material, etc. Includes Mechanical Schedule and Chiltris Schedule.

Table with 10 columns: No., Description, Unit Location, Size, Material, etc. Includes Mechanical Schedule and Chiltris Schedule.

Table with 10 columns: No., Description, Unit Location, Size, Material, etc. Includes Mechanical Schedule and Chiltris Schedule.

Table with 10 columns: No., Description, Unit Location, Size, Material, etc. Includes Mechanical Schedule and Chiltris Schedule.

Table with 10 columns: No., Description, Unit Location, Size, Material, etc. Includes Mechanical Schedule and Chiltris Schedule.

Table with 10 columns: No., Description, Unit Location, Size, Material, etc. Includes Mechanical Schedule and Chiltris Schedule.

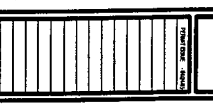
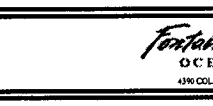

436 COLLINS AVENUE, MIAMI BEACH, FL 33146

Fontainebleau III OCEAN CLUB

Fontainebleau III OCEAN CLUB

Fontainebleau III OCEAN CLUB

Fontainebleau III OCEAN CLUB

Fontainebleau III OCEAN CLUB

Fontainebleau III OCEAN CLUB

Fontainebleau III OCEAN CLUB

WATER EXPANSION TANK PIPING DETAIL
N.T.S.

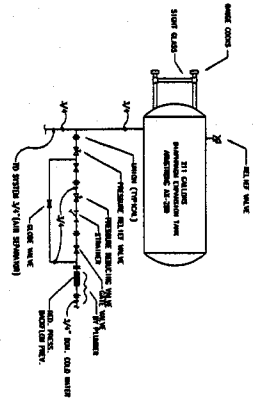

DETAILS WITH AND WITHOUT FLOAT VALVE

THIS TANK SHALL BE INSTALLED IN A VENTILATED SPACE. THE TANK SHALL BE SUPPORTED BY A FRAMEWORK OF STEEL OR CONCRETE. THE TANK SHALL BE PROTECTED BY AN AUTOMATIC FLOOD EXTINGUISHING SYSTEM. THE TANK SHALL BE MAINTAINED AT ALL TIMES IN A CLEAN AND SERVICEABLE CONDITION. THE TANK SHALL BE INSULATED TO PREVENT CONDENSATION. THE TANK SHALL BE PAINTED WITH AN ANTI-RUST PAINT. THE TANK SHALL BE TESTED TO 150% OF THE DESIGN PRESSURE. THE TANK SHALL BE MAINTAINED AT ALL TIMES IN A CLEAN AND SERVICEABLE CONDITION. THE TANK SHALL BE INSULATED TO PREVENT CONDENSATION. THE TANK SHALL BE PAINTED WITH AN ANTI-RUST PAINT. THE TANK SHALL BE TESTED TO 150% OF THE DESIGN PRESSURE.

CHILLER ROOM PIPING DETAIL
N.T.S.

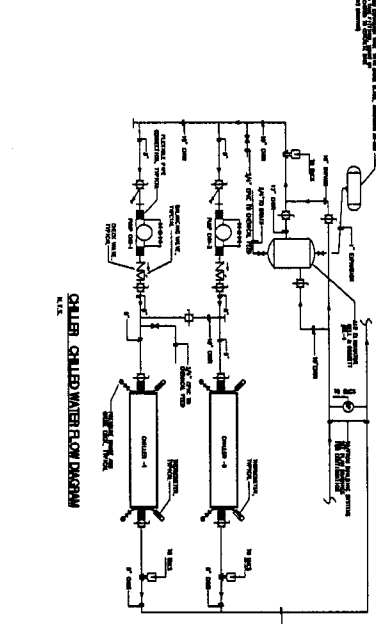

CHILLER ROOM PIPING DETAIL DESCRIPTION

1. CHILLER ROOM PIPING SHALL BE INSTALLED IN ACCORDANCE WITH THE FOLLOWING REQUIREMENTS:

1. CHILLER ROOM PIPING SHALL BE INSTALLED IN ACCORDANCE WITH THE FOLLOWING REQUIREMENTS:
2. CHILLER ROOM PIPING SHALL BE INSTALLED IN ACCORDANCE WITH THE FOLLOWING REQUIREMENTS:
3. CHILLER ROOM PIPING SHALL BE INSTALLED IN ACCORDANCE WITH THE FOLLOWING REQUIREMENTS:
4. CHILLER ROOM PIPING SHALL BE INSTALLED IN ACCORDANCE WITH THE FOLLOWING REQUIREMENTS:
5. CHILLER ROOM PIPING SHALL BE INSTALLED IN ACCORDANCE WITH THE FOLLOWING REQUIREMENTS:
6. CHILLER ROOM PIPING SHALL BE INSTALLED IN ACCORDANCE WITH THE FOLLOWING REQUIREMENTS:
7. CHILLER ROOM PIPING SHALL BE INSTALLED IN ACCORDANCE WITH THE FOLLOWING REQUIREMENTS:
8. CHILLER ROOM PIPING SHALL BE INSTALLED IN ACCORDANCE WITH THE FOLLOWING REQUIREMENTS:
9. CHILLER ROOM PIPING SHALL BE INSTALLED IN ACCORDANCE WITH THE FOLLOWING REQUIREMENTS:
10. CHILLER ROOM PIPING SHALL BE INSTALLED IN ACCORDANCE WITH THE FOLLOWING REQUIREMENTS:

CONDENSED WATER FLOW AND CONTROL DIAGRAM
N.T.S.

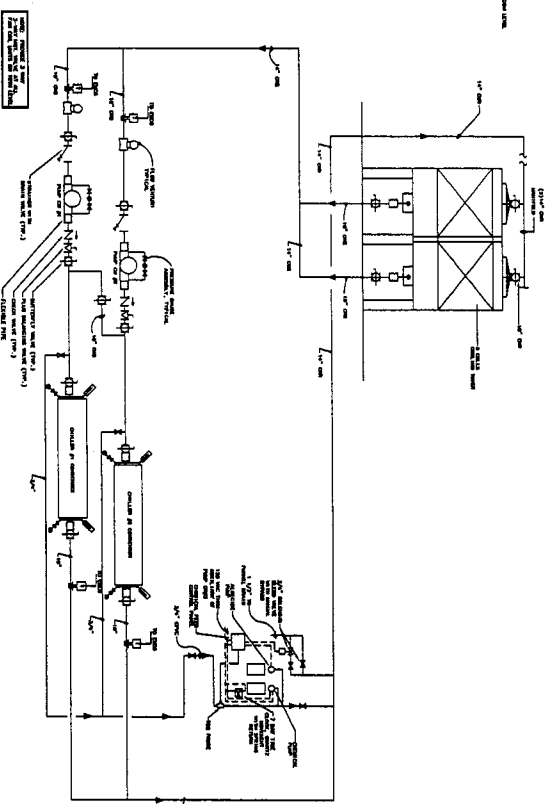

- ISOLATING TUBING ASSEMBLY**
1. PROVIDE STAINLESS STEEL ACCESSORIES
 2. PROVIDE STAINLESS STEEL ACCESSORIES
 3. PROVIDE STAINLESS STEEL ACCESSORIES
 4. PROVIDE STAINLESS STEEL ACCESSORIES
 5. PROVIDE STAINLESS STEEL ACCESSORIES
 6. PROVIDE STAINLESS STEEL ACCESSORIES
 7. PROVIDE STAINLESS STEEL ACCESSORIES
 8. PROVIDE STAINLESS STEEL ACCESSORIES
 9. PROVIDE STAINLESS STEEL ACCESSORIES
 10. PROVIDE STAINLESS STEEL ACCESSORIES

TYPICAL CHILLED WATER BEDDING DETAIL
N.T.S.

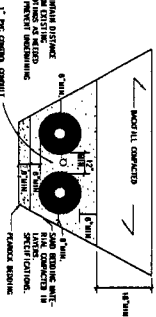

- CHILLER ROOM PIPING DETAIL DESCRIPTION**
1. CHILLER ROOM PIPING SHALL BE INSTALLED IN ACCORDANCE WITH THE FOLLOWING REQUIREMENTS:
 2. CHILLER ROOM PIPING SHALL BE INSTALLED IN ACCORDANCE WITH THE FOLLOWING REQUIREMENTS:
 3. CHILLER ROOM PIPING SHALL BE INSTALLED IN ACCORDANCE WITH THE FOLLOWING REQUIREMENTS:
 4. CHILLER ROOM PIPING SHALL BE INSTALLED IN ACCORDANCE WITH THE FOLLOWING REQUIREMENTS:
 5. CHILLER ROOM PIPING SHALL BE INSTALLED IN ACCORDANCE WITH THE FOLLOWING REQUIREMENTS:
 6. CHILLER ROOM PIPING SHALL BE INSTALLED IN ACCORDANCE WITH THE FOLLOWING REQUIREMENTS:
 7. CHILLER ROOM PIPING SHALL BE INSTALLED IN ACCORDANCE WITH THE FOLLOWING REQUIREMENTS:
 8. CHILLER ROOM PIPING SHALL BE INSTALLED IN ACCORDANCE WITH THE FOLLOWING REQUIREMENTS:
 9. CHILLER ROOM PIPING SHALL BE INSTALLED IN ACCORDANCE WITH THE FOLLOWING REQUIREMENTS:
 10. CHILLER ROOM PIPING SHALL BE INSTALLED IN ACCORDANCE WITH THE FOLLOWING REQUIREMENTS:

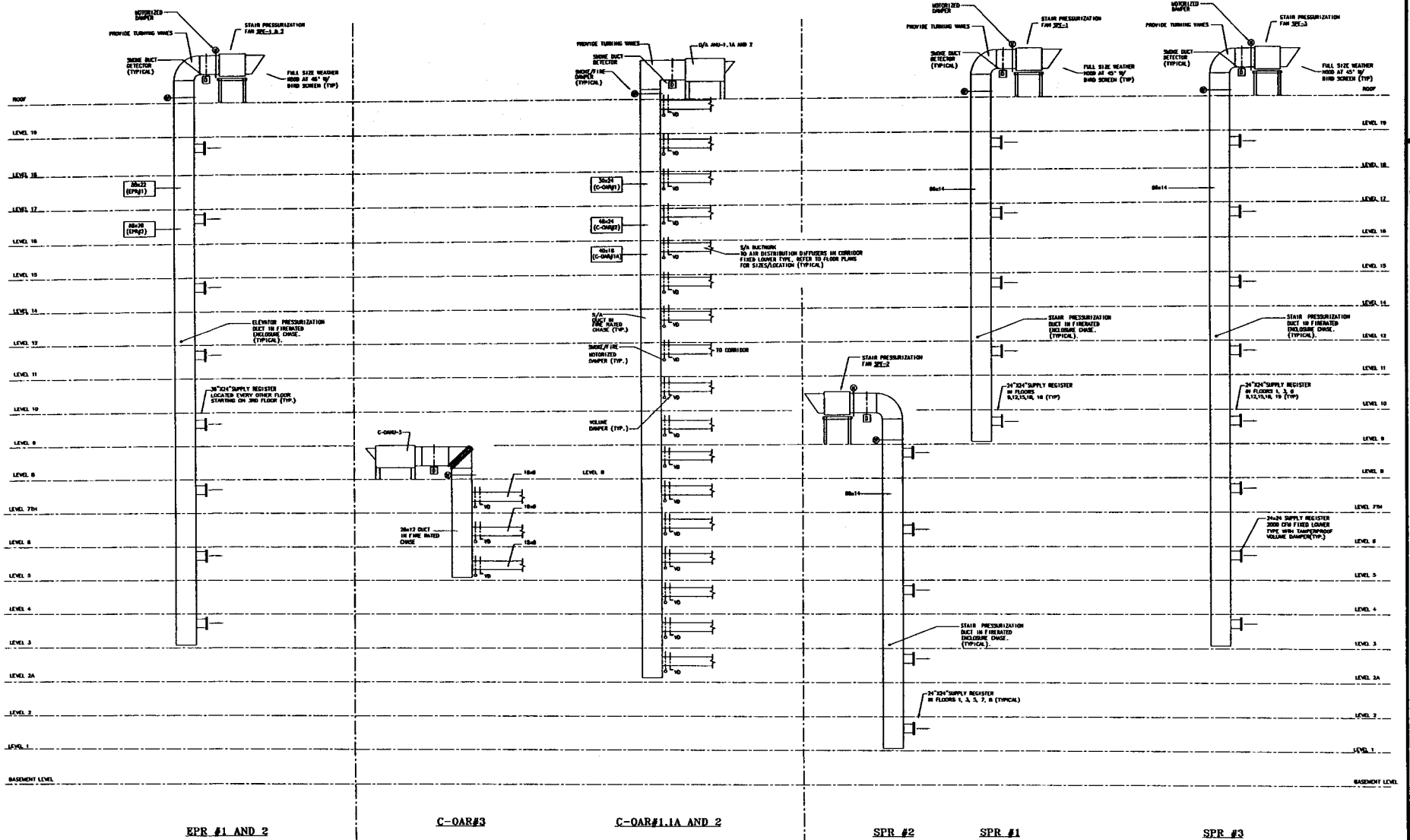

ELEVATOR PRESSURIZATION RISER DIAGRAMS
N.T.S.

CORRIDOR O/A PRESSURIZATION RISER DIAGRAMS
N.T.S.

STAIR PRESSURIZATION RISER DIAGRAMS

NOTE: PROVIDE .50" STATIC HEADROOM AT STAIRS.

70
NICHOLS BROSH WEST WOLF
 ARCHITECTS & ENGINEERS
 2285
Fountainbleau III
 OCEAN CLUB
 2285 COLLEGE AVENUE, SUITE 300 BEACH, FL 33408
 M-6.03

TOILET EXHAUST RISER DIAGRAMS
A1.3

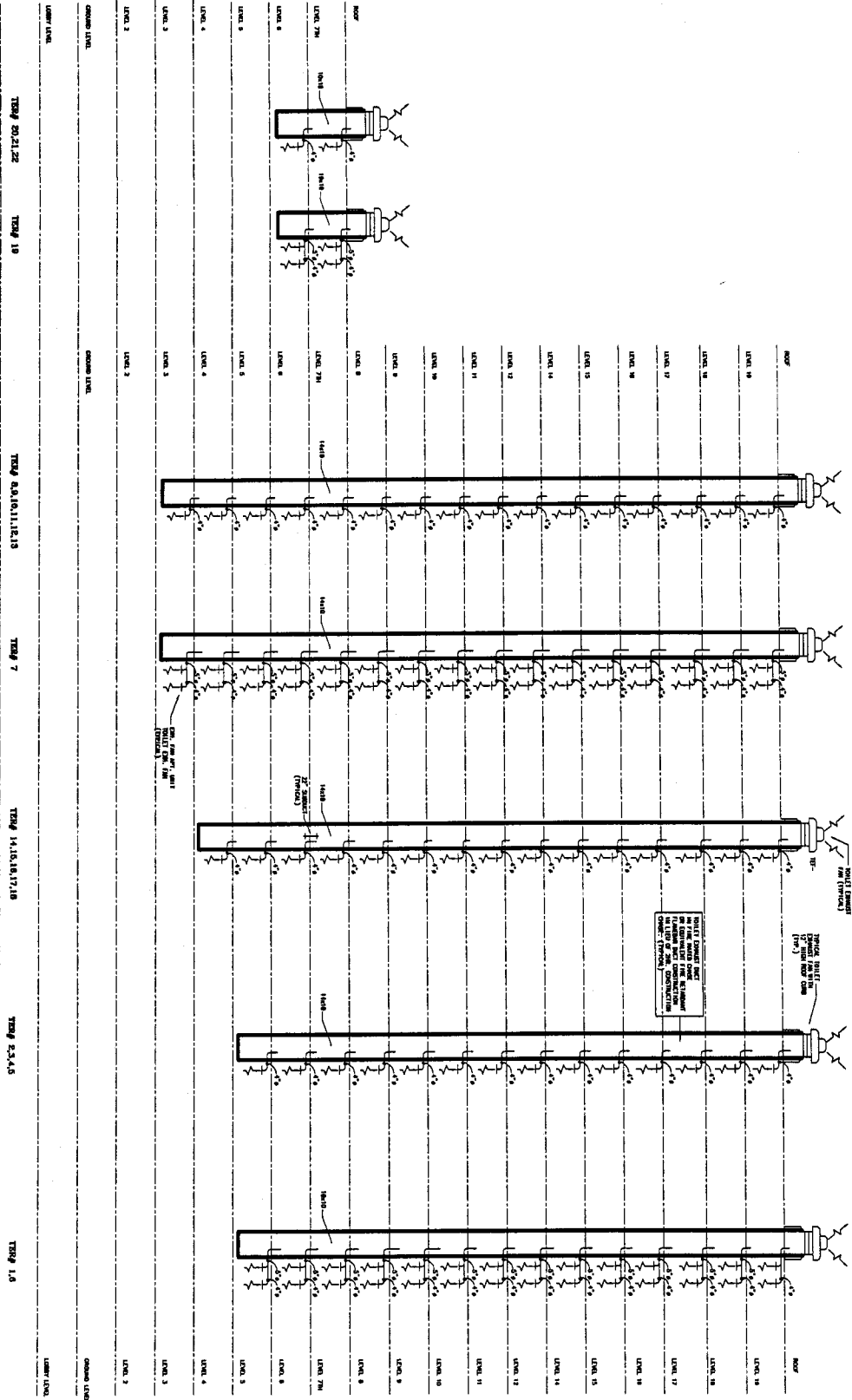

ALL ELEVATION MARKS REFER TO N.G. V.D.

M-0.04

2785

Fountainbleau III
OCEAN CLUB
4390 COLLINS AVENUE, MIAMI BEACH, FL 33142

NOTES:
1. PROJECT SUBJECT MATTER WILL BE WORKED UPON AS SHOWN ON THIS SHEET.

CHILLED WATER RESERV. DIAGRAM

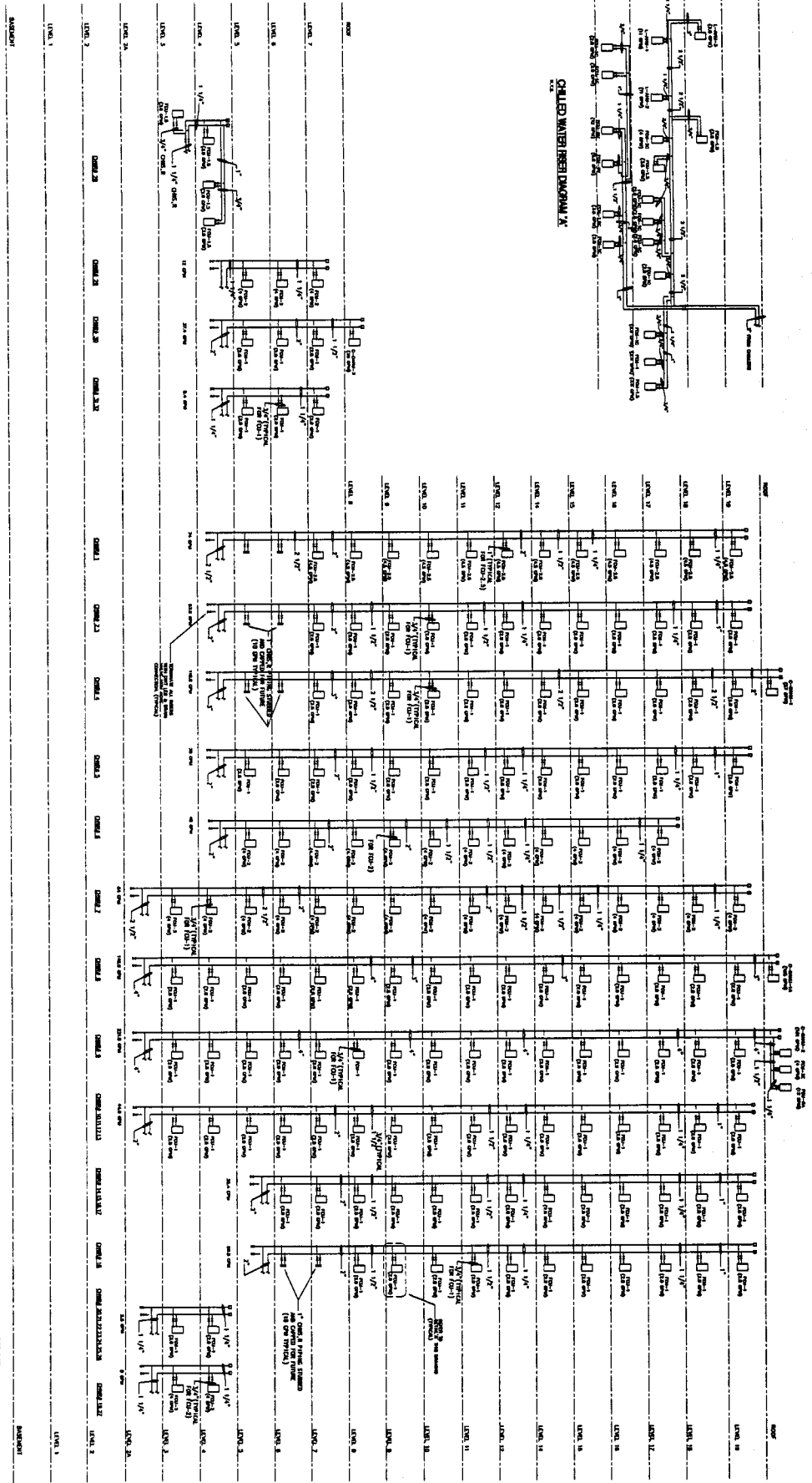
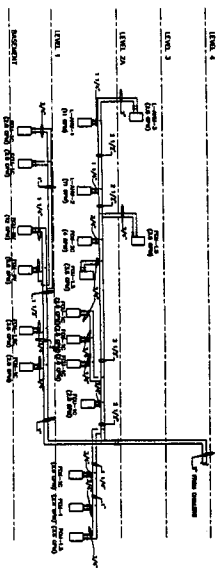

CHILLED WATER RESER. DIAGRAM

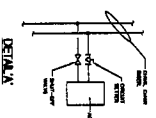

DETAIL A

ALL ELEVATION MARKS REFER TO N.G.D.

		4380 COLLINS AVENUE, MIAMI BEACH, FL 33140			

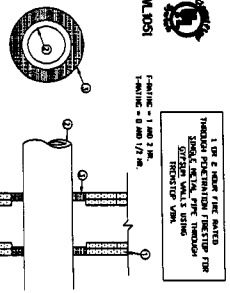

- 1. ONE HOUR FIRE RATED FLOOR**
 THROUGH PENETRATIONS THROUGH FIRE RATED FLOOR SHALL BE FIRE RATED PENETRATIONS.
 FLOORING - 1/2" MIN.
 FLOORING - 3/4" MIN.
 FLOORING - 1/2" MIN.

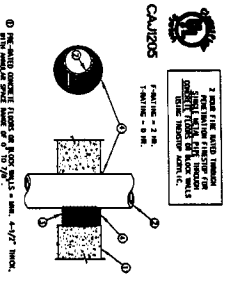

- 2. ONE HOUR FIRE RATED FLOOR**
 THROUGH PENETRATIONS THROUGH FIRE RATED FLOOR SHALL BE FIRE RATED PENETRATIONS.
 FLOORING - 1/2" MIN.
 FLOORING - 3/4" MIN.
 FLOORING - 1/2" MIN.

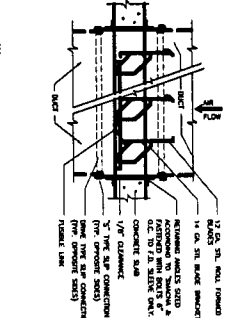

- NOTES:**
 1. DAMPER SHALL BE 1/2" TO 1/4" IN SIZE.
 2. DAMPER SHALL BE INSTALLED IN ACCORDANCE WITH THE MANUFACTURER'S INSTRUCTIONS.
 3. DAMPER SHALL BE INSTALLED IN ACCORDANCE WITH THE MANUFACTURER'S INSTRUCTIONS.
 4. DAMPER SHALL BE INSTALLED IN ACCORDANCE WITH THE MANUFACTURER'S INSTRUCTIONS.
 5. DAMPER SHALL BE INSTALLED IN ACCORDANCE WITH THE MANUFACTURER'S INSTRUCTIONS.
 6. DAMPER SHALL BE INSTALLED IN ACCORDANCE WITH THE MANUFACTURER'S INSTRUCTIONS.
 7. DAMPER SHALL BE INSTALLED IN ACCORDANCE WITH THE MANUFACTURER'S INSTRUCTIONS.
 8. DAMPER SHALL BE INSTALLED IN ACCORDANCE WITH THE MANUFACTURER'S INSTRUCTIONS.
 9. DAMPER SHALL BE INSTALLED IN ACCORDANCE WITH THE MANUFACTURER'S INSTRUCTIONS.
 10. DAMPER SHALL BE INSTALLED IN ACCORDANCE WITH THE MANUFACTURER'S INSTRUCTIONS.

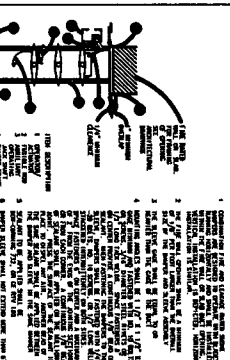

- NOTES:**
 1. DAMPER SHALL BE 1/2" TO 1/4" IN SIZE.
 2. DAMPER SHALL BE INSTALLED IN ACCORDANCE WITH THE MANUFACTURER'S INSTRUCTIONS.
 3. DAMPER SHALL BE INSTALLED IN ACCORDANCE WITH THE MANUFACTURER'S INSTRUCTIONS.
 4. DAMPER SHALL BE INSTALLED IN ACCORDANCE WITH THE MANUFACTURER'S INSTRUCTIONS.
 5. DAMPER SHALL BE INSTALLED IN ACCORDANCE WITH THE MANUFACTURER'S INSTRUCTIONS.
 6. DAMPER SHALL BE INSTALLED IN ACCORDANCE WITH THE MANUFACTURER'S INSTRUCTIONS.
 7. DAMPER SHALL BE INSTALLED IN ACCORDANCE WITH THE MANUFACTURER'S INSTRUCTIONS.
 8. DAMPER SHALL BE INSTALLED IN ACCORDANCE WITH THE MANUFACTURER'S INSTRUCTIONS.
 9. DAMPER SHALL BE INSTALLED IN ACCORDANCE WITH THE MANUFACTURER'S INSTRUCTIONS.
 10. DAMPER SHALL BE INSTALLED IN ACCORDANCE WITH THE MANUFACTURER'S INSTRUCTIONS.

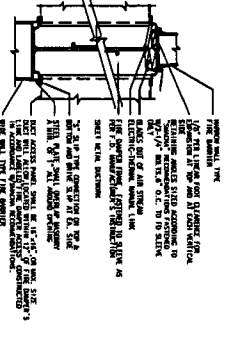

- NOTES:**
 1. DAMPER SHALL BE 1/2" TO 1/4" IN SIZE.
 2. DAMPER SHALL BE INSTALLED IN ACCORDANCE WITH THE MANUFACTURER'S INSTRUCTIONS.
 3. DAMPER SHALL BE INSTALLED IN ACCORDANCE WITH THE MANUFACTURER'S INSTRUCTIONS.
 4. DAMPER SHALL BE INSTALLED IN ACCORDANCE WITH THE MANUFACTURER'S INSTRUCTIONS.
 5. DAMPER SHALL BE INSTALLED IN ACCORDANCE WITH THE MANUFACTURER'S INSTRUCTIONS.
 6. DAMPER SHALL BE INSTALLED IN ACCORDANCE WITH THE MANUFACTURER'S INSTRUCTIONS.
 7. DAMPER SHALL BE INSTALLED IN ACCORDANCE WITH THE MANUFACTURER'S INSTRUCTIONS.
 8. DAMPER SHALL BE INSTALLED IN ACCORDANCE WITH THE MANUFACTURER'S INSTRUCTIONS.
 9. DAMPER SHALL BE INSTALLED IN ACCORDANCE WITH THE MANUFACTURER'S INSTRUCTIONS.
 10. DAMPER SHALL BE INSTALLED IN ACCORDANCE WITH THE MANUFACTURER'S INSTRUCTIONS.

FIRESTOP DETAIL - 1 N.T.S.

FIRESTOP DETAIL - 2 N.T.S.

TYPICAL FIRE DAMPER SLAB MOUNTING DETAIL N.T.S.

COMBUSTION PRE/SMOKE DAMPER DETAIL N.T.S.

TYPICAL FIRE DAMPER MOUNTING DETAIL N.T.S.

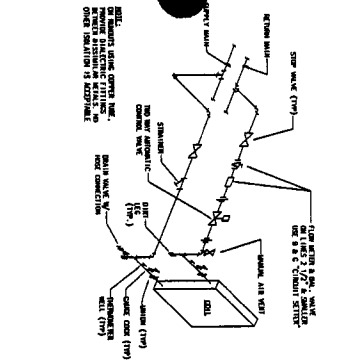

TYPICAL VERTICAL AIR CONTROL VALVE DETAIL - 1 N.T.S.

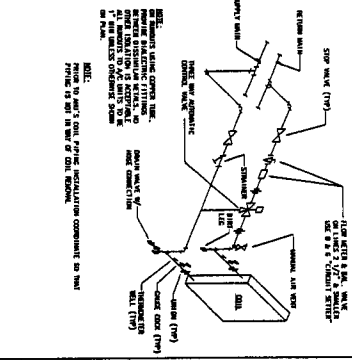

TYPICAL VERTICAL AIR CONTROL VALVE DETAIL - 2 N.T.S.

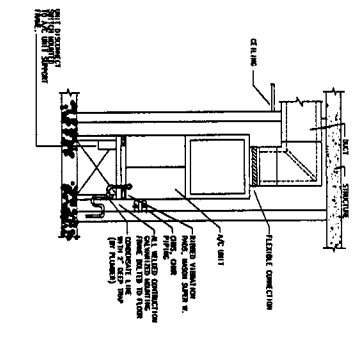

TYPICAL VERTICAL AIR MOUNTING DETAIL N.T.S.

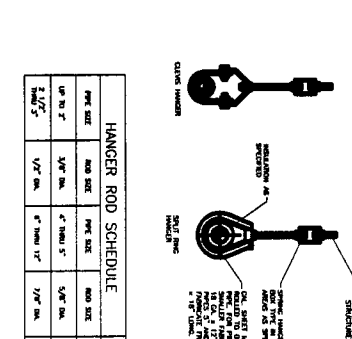

TYPICAL FIRE HANGER DETAILS N.T.S.

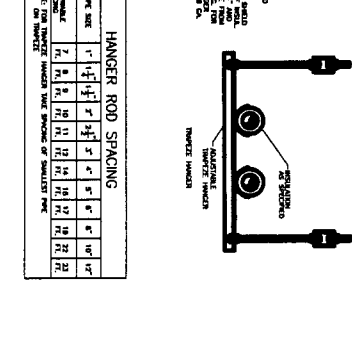

TYPICAL FIRE DAMPER MOUNTING DETAIL N.T.S.

HANGER ROD SCHEDULE				HANGER ROD SPACING			
PIPE SIZE	ROD SIZE	ROD SIZE	ROD SIZE	PIPE SIZE	ROD SIZE	ROD SIZE	ROD SIZE
UP TO 2"	3/8" DIA.	1/2" DIA.	5/8" DIA.	1"	1/2"	1/2"	1/2"
2 1/2"	1/2" DIA.	3/4" DIA.	1" DIA.	2"	3/4"	3/4"	3/4"
3"	5/8" DIA.	3/4" DIA.	1" DIA.	3"	3/4"	3/4"	3/4"
4"	3/4" DIA.	1" DIA.	1 1/4" DIA.	4"	3/4"	3/4"	3/4"
5"	7/8" DIA.	1 1/4" DIA.	1 1/2" DIA.	5"	3/4"	3/4"	3/4"
6"	1" DIA.	1 1/4" DIA.	1 1/2" DIA.	6"	3/4"	3/4"	3/4"
8"	1 1/4" DIA.	1 1/2" DIA.	1 3/4" DIA.	8"	3/4"	3/4"	3/4"
10"	1 1/2" DIA.	1 3/4" DIA.	2" DIA.	10"	3/4"	3/4"	3/4"
12"	1 3/4" DIA.	2" DIA.	2 1/4" DIA.	12"	3/4"	3/4"	3/4"

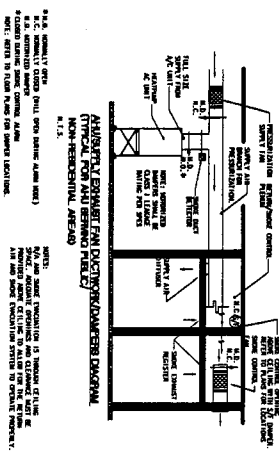

TYPICAL FIRE DAMPER MOUNTING DETAIL N.T.S.

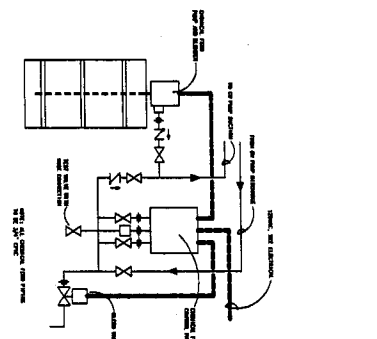

CONDENSER WATER CHEMICAL FEED

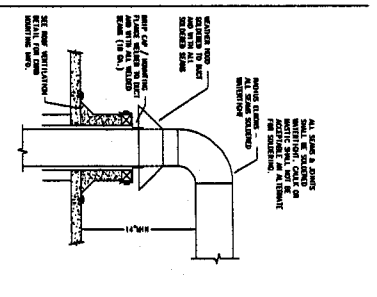

TYPICAL DUCT OFFSET ABOVE ROOF

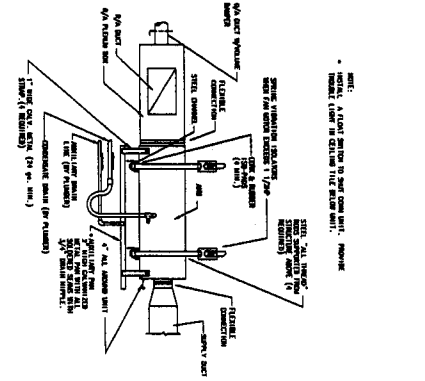

SUGGESTED HORIZONTAL AHU MOUNTING DETAIL

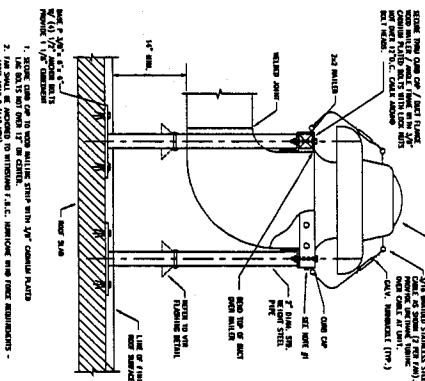

FAN EQUIPMENT SUPPORT DETAIL

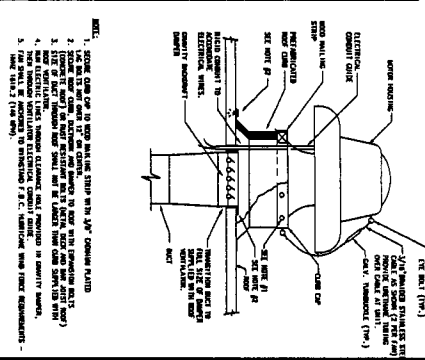

POWER TYPE ROOF VENTILATOR

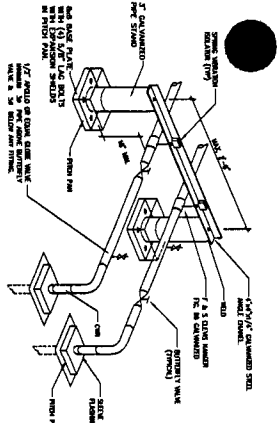

TYPICAL ROOF PIPE SUPPORT DETAIL

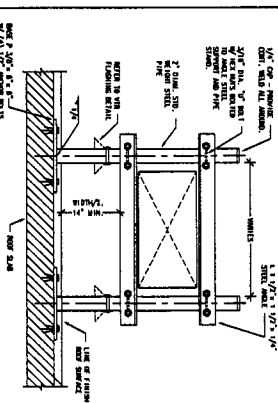

DUCTWORK • ROOF SUPPORT DETAIL

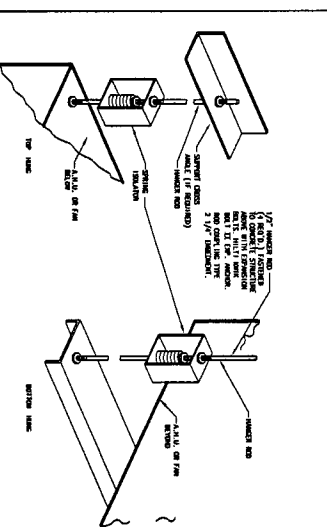

FAN OR A/C UNIT MOUNTING DETAIL

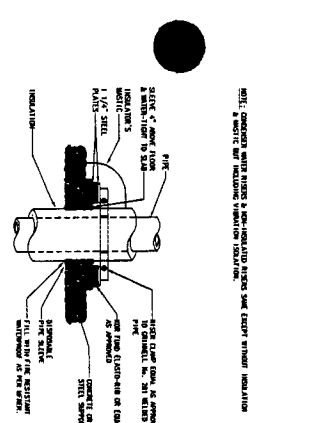

VERTICAL PIPING RISER DETAIL

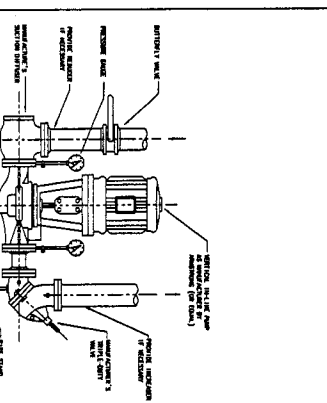

CONDENSER-COOLED WATER PUMP DETAIL

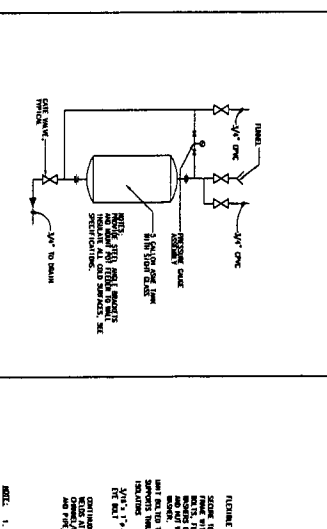

CHILLED WATER POT-TYPE CHEMICAL FEEDER

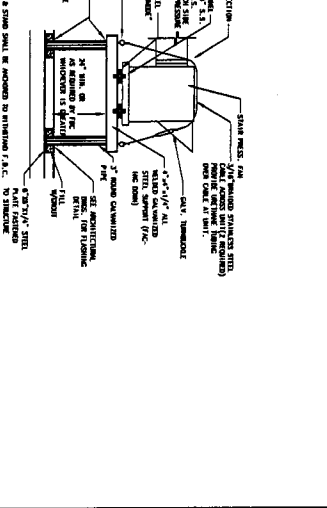

STAIR ELEVATOR PRESS FAN MOUNTING DETAIL

P:\980036\8-8-00

STANDARD 1" WIRE HANGERS
 HANGER EXTENSION IS KEY WORD AS THE SUM OF THE DISTANCES BETWEEN THE HANGING STRIPS AND THE DUCT WALLS (BOTH SIDES).

MAINTAIN HANGER SPACING BY BACK SIZE, I.D.

DUCT SIZE, WIDTH & SPACING	MAXIMUM HANGER SPACING
4" wide or greater	4 FT
Less than 4" wide and 8 FT less than 48" Spacing	8 FT
Width between 24" & 48" and greater than 18" Spacing	8 FT
Less than 24" wide and 8 FT 18" depth or less	8 FT

IF OVER EXTENSION IS NOT GREATER THAN:	CHANNEL PROFILE	CHANNEL DIMENSIONS
6"	24	3"x1.5"
12"	22	3"x2"
36"	18	3"x2"

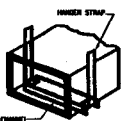

REFER TO SHEET 05.3 FOR HANGING DIMENSION STANDARD DETAILS FOR REINFORCEMENTS SCHEDULES.

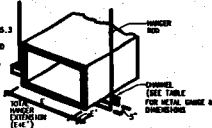

FIBERGLASS DUCT HANGER DETAIL
 N.T.S.

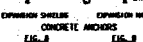
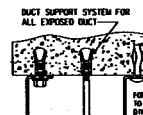
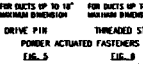
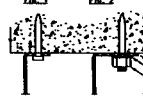
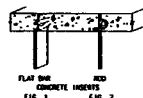

HANGERS FOR DUCTS - UPPER/LOWER ATTACHMENTS
 SCALE: N.T.S.
 ALL WORK SHALL BE PERFORMED AS PER DIMENSION STANDARDS.

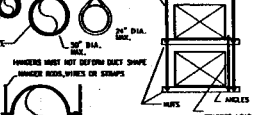
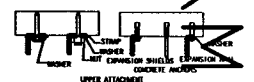

HANGERS FOR DUCTS - UPPER/LOWER ATTACHMENTS
 SCALE: N.T.S.
 ALL WORK SHALL BE PERFORMED AS PER DIMENSION STANDARDS.



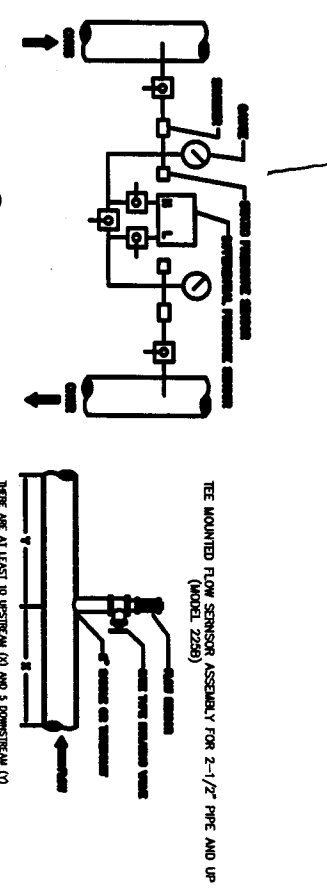

NOTE 1
 COOLING TOWER (T/O) WILL BE WIRED TO A CONTROLLER LOCATED ON THE ROOF LEVEL. SEE SCHEMATIC BELOW.

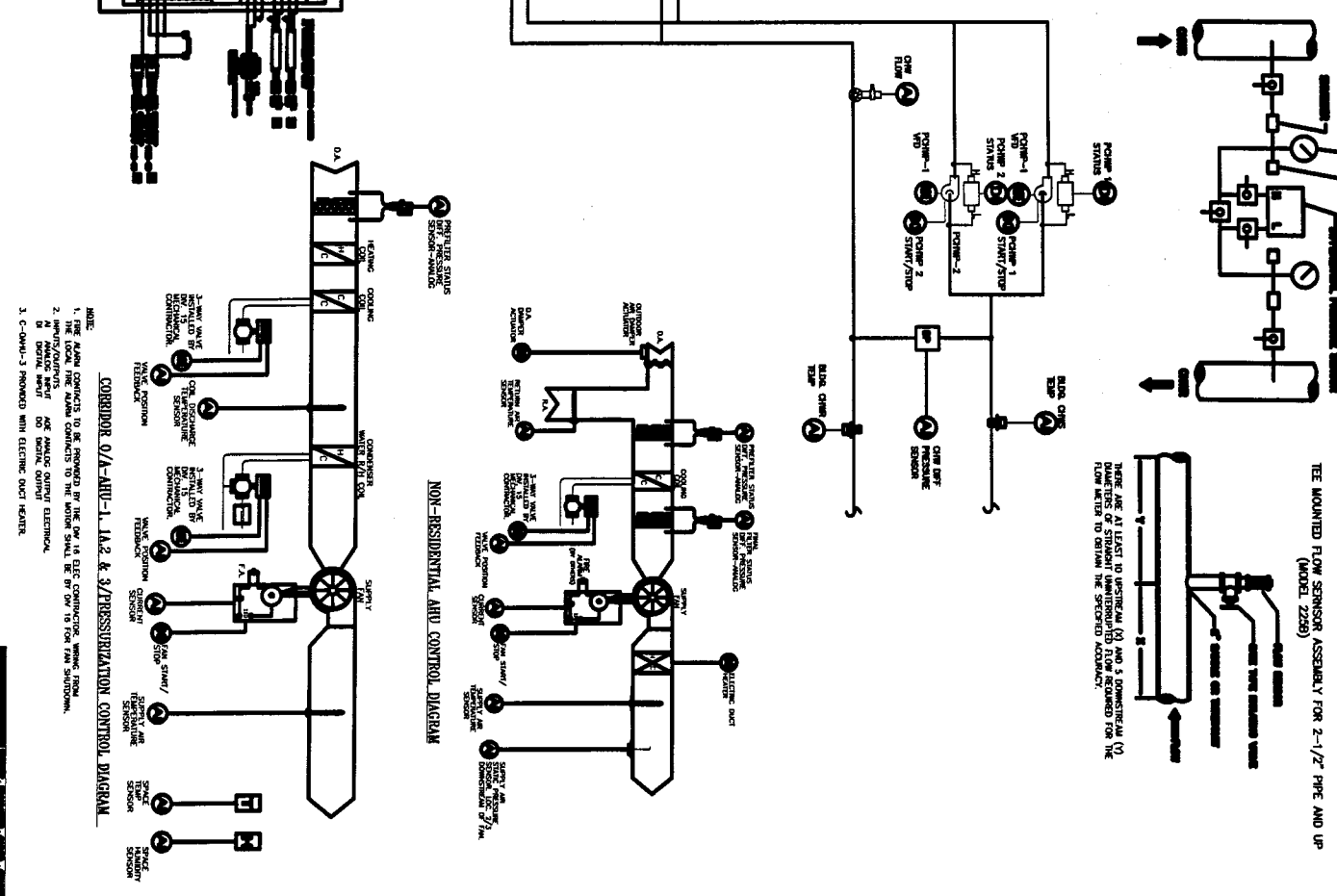
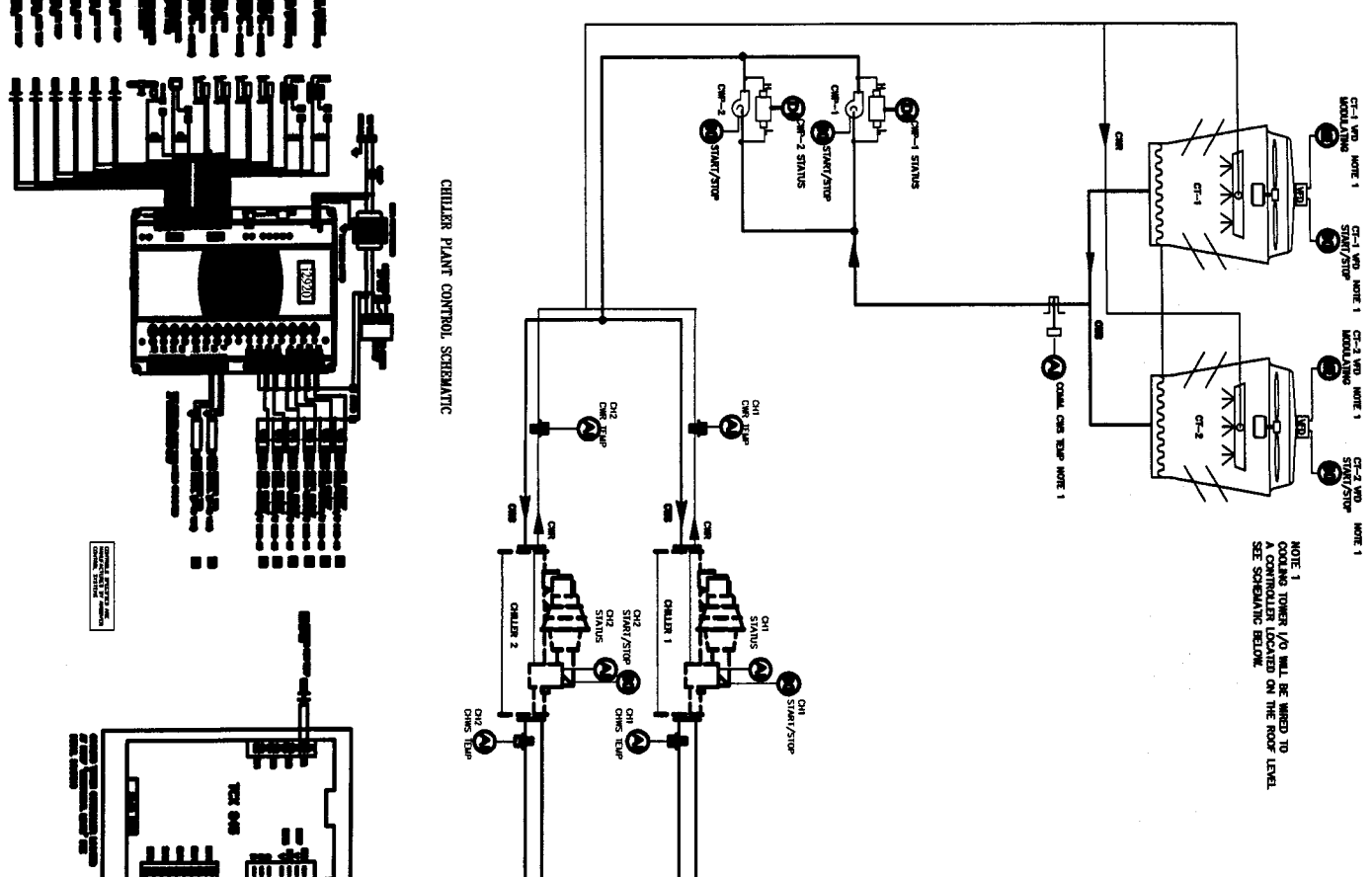

Fontainebleau III
 OCEAN CLUB
 1300 COLLINS AVENUE, MIAMI BEACH, FL 33140

NON-RESIDENTIAL WATER WORKS

M-700
 2285

PL ELEVATION MARKS REFER TO N.O.D.P.

SMOKE CONTROL SYSTEM CONTROL DIAGRAMS

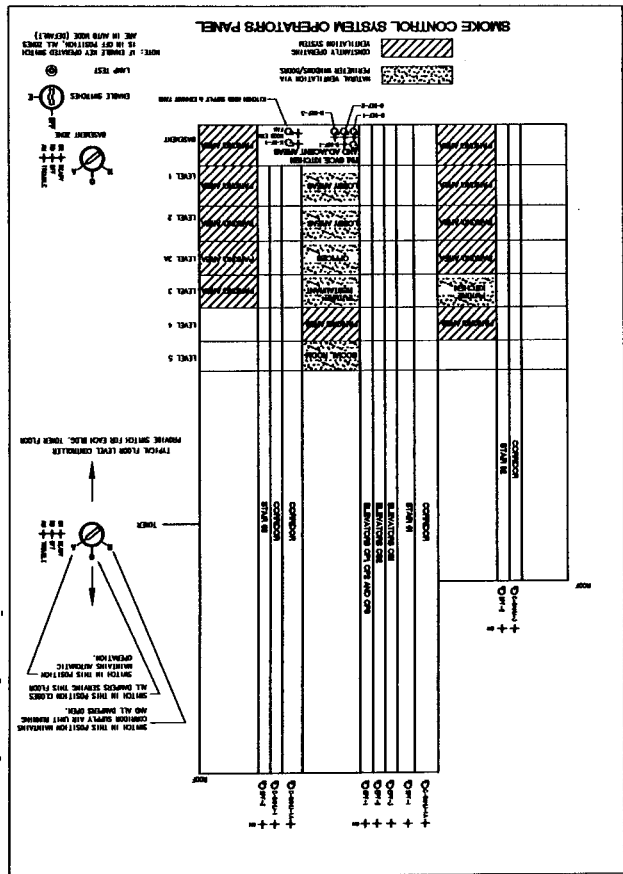
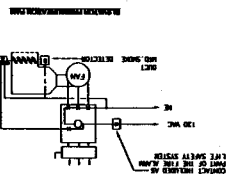
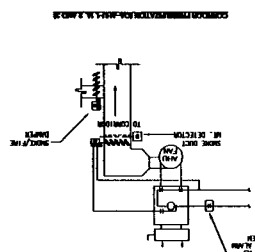
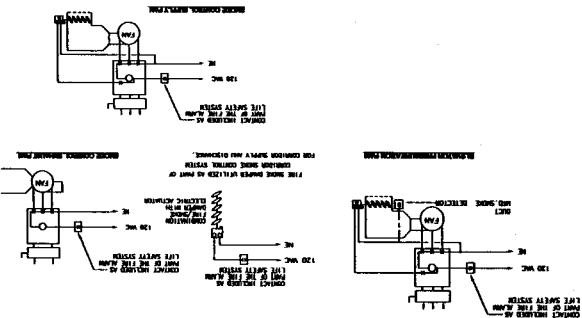

- SEQUENCE OF OPERATION**
1. Upon fire alarm signal (sound or when rising fire is detected), the smoke control system shall be initiated.
 2. All smoke exhaust fans shall be started.
 3. All smoke exhaust fans shall be started.
 4. All smoke exhaust fans shall be started.
 5. All smoke exhaust fans shall be started.
 6. All smoke exhaust fans shall be started.
 7. All smoke exhaust fans shall be started.
 8. All smoke exhaust fans shall be started.
 9. All smoke exhaust fans shall be started.
 10. All smoke exhaust fans shall be started.
 11. All smoke exhaust fans shall be started.
 12. All smoke exhaust fans shall be started.
 13. All smoke exhaust fans shall be started.
 14. All smoke exhaust fans shall be started.
 15. All smoke exhaust fans shall be started.
 16. All smoke exhaust fans shall be started.
 17. All smoke exhaust fans shall be started.
 18. All smoke exhaust fans shall be started.
 19. All smoke exhaust fans shall be started.
 20. All smoke exhaust fans shall be started.

NETWORK CONTROL DIAGRAM

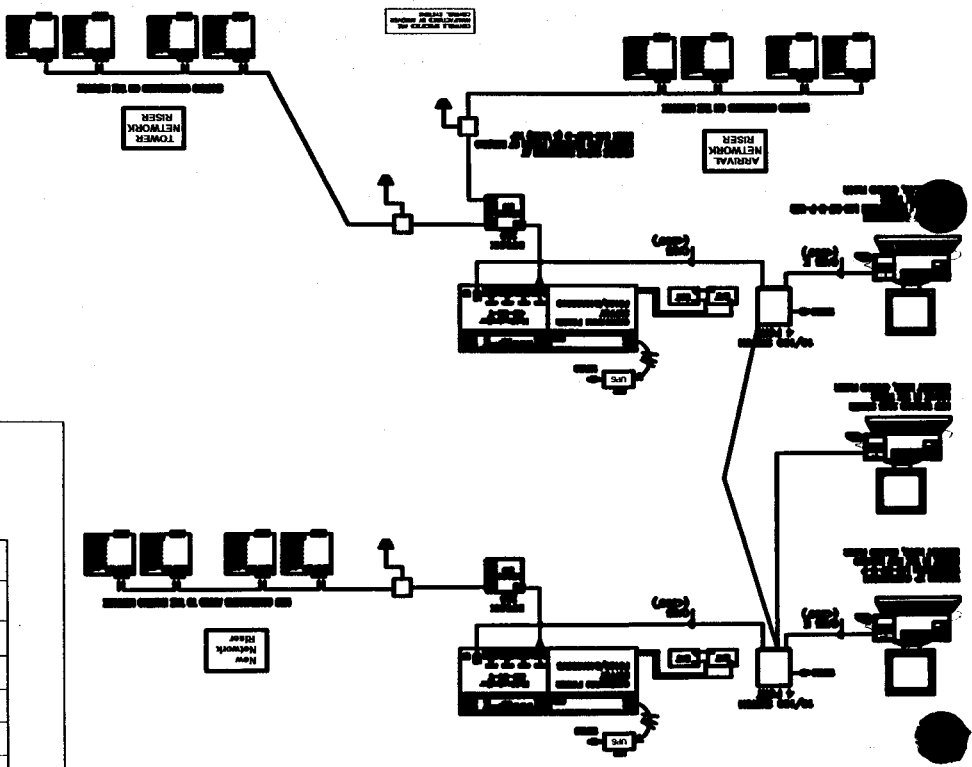

STARWELL AND ELEVATOR PRESS, FAN CONTROL DIAGRAMS

