



Florida Regulatory Relations T: 850-577-5550  
150 S. Monroe St., Suite 400 F: 850-224-5073  
Tallahassee, FL 32301 www.att.com

070198-TP

March 19, 2007

ORIGINAL

RECEIVED: FPSC  
07 MAR 29 PM 1:59  
COMMISSION  
CLERK

Mrs. Ann Cole  
Director, Division of the Commission Clerk and Administrative Services  
Florida Public Service Commission  
2540 Shumard Oak Boulevard  
Tallahassee, Florida 32399

Re: Approval of Interconnection, Unbundling, Resale and Collocation Agreement  
between AT&T Florida f/k/a "BellSouth" and Smart City Solutions, LLC d/b/a Smart  
City Communications

Dear Mrs. Cole:

Please find enclosed for filing and approval, the original and two copies of the  
Interconnection, Unbundling, Resale and Collocation Agreement between AT&T  
Florida f/k/a "BellSouth" and Smart City Solutions, LLC d/b/a Smart City  
Communications

If you have any questions please do not hesitate to contact Robyn Holland at (850) 577-  
5551.

Very truly yours,

*Gerry D. Kendrick/RN*  
Regulatory Vice President

RECEIVED & FILED

R.V.N.  
BUREAU OF RECORDS

DOCUMENT NUMBER-DATE

02708 MAR 29 5

FPSC-COMMISSION CLERK

# **BELLSOUTH® / CLEC Agreement**

**Customer Name: Smart City Solutions, LLC d/b/a Smart City Communications**

Smart City Solutions, LLC dba Smart City Communications 4Q06 TRRO Compliant	2
Interconnection Agreement	
Table of Contents	3
General Terms and Conditions	5
Signature Page	25
Att 1 - Resale	26
Att 1 - Resale Discounts & Rates	46
Att 2 - Network Elements & Other Services	47
Att 2 - Network Element Rates - Exhibit A	97
Att 2 - Network Elements Rates - Exhibit B	108
Att 2 - Network Elements - Exhibit C	110
Att 3 - Network Interconnection	113
Att 3 - Local Interconnection Rates	144
Att 4 - Collocation	146
Att 4 - Collocation Rates - Exhibit B	195
Att 5 - Access to Numbers and Number Portability	200
Att 6 - Ordering	205
Att 7 - Billing	215
Att 8 - Rights of Way	226
Att 9 - Service Quality Measurements	228
Att 10 - Disaster Recovery Plan	230
Att 11 - BFR and NBR Process	239

**Interconnection Agreement**

**Between**

**BellSouth Telecommunications, Inc.**

**and**

**Smart City Solutions, LLC d/b/a Smart City Communications**

## **TABLE OF CONTENTS**

### **General Terms and Conditions**

- Definitions**
- 1. CLEC Certification**
- 2. Term of the Agreement**
- 3. Nondiscriminatory Access**
- 4. Court Ordered Requests for Call Detail Records and Other Subscriber Information**
- 5. Liability and Indemnification**
- 6. Intellectual Property Rights and Indemnification**
- 7. Proprietary and Confidential Information**
- 8. Resolution of Disputes**
- 9. Taxes**
- 10. Force Majeure**
- 11. Adoption of Agreements**
- 12. Modification of Agreement**
- 13. Legal Rights**
- 14. Indivisibility**
- 15. Severability**
- 16. Non-Waivers**
- 17. Governing Law**
- 18. Assignments and Transfers**
- 19. Notices**
- 20. Rule of Construction**
- 21. Headings of No Force or Effect**
- 22. Multiple Counterparts**
- 23. Filing of Agreement**
- 24. Compliance with Law**
- 25. Necessary Approvals**
- 26. Good Faith Performance**
- 27. Rates**
- 28. Rate True-Up**
- 29. Survival**
- 30. Entire Agreement**



## **TABLE OF CONTENTS (cont'd)**

**Attachment 1 - Resale**

**Attachment 2 - Network Elements and Other Services**

**Attachment 3 - Network Interconnection**

**Attachment 4 - Collocation**

**Attachment 5 - Access to Numbers and Number Portability**

**Attachment 6 - Pre-Ordering, Ordering, Provisioning and Maintenance and Repair**

**Attachment 7 - Billing**

**Attachment 8 - Rights-of-Way, Conduits and Pole Attachments**

**Attachment 9 - Service Quality Measurements**

**Attachment 10 - BellSouth Disaster Recovery Plan**

**Attachment 11 - Bona Fide Request and New Business Request Process**

## **AGREEMENT GENERAL TERMS AND CONDITIONS**

**THIS AGREEMENT** is made by and between BellSouth Telecommunications, Inc., (BellSouth), a Georgia corporation, and Smart City Solutions, LLC d/b/a Smart City Communications (Smart City Communications), a Florida limited liability company, and shall be effective on the Effective Date, as defined herein. This Agreement may refer to either BellSouth or Smart City Communications or both as a “Party” or “Parties.”

### **W I T N E S S E T H**

**WHEREAS**, BellSouth is a local exchange telecommunications company authorized to provide Telecommunications Services (as defined below) in the states of Alabama, Florida, Georgia, Kentucky, Louisiana, Mississippi, North Carolina, South Carolina and Tennessee; and

**WHEREAS**, Smart City Communications is or seeks to become a CLEC authorized to provide telecommunications services in the state of Florida; and

**WHEREAS**, pursuant to Sections 251 and 252 of the Act; Smart City Communications wishes to purchase certain services from BellSouth; and

**WHEREAS**, the Parties wish to interconnect their facilities, exchange traffic, and perform Local Number Portability (LNP) pursuant to Sections 251 and 252 of the Act as set forth herein; and

**WHEREAS**, Smart City Communications wishes to purchase and BellSouth wishes to provide other services as described in this Agreement;

**NOW THEREFORE**, in consideration of the mutual agreements contained herein, BellSouth and Smart City Communications agree as follows:

#### **Definitions**

**Affiliate** is defined as a person that (directly or indirectly) owns or controls, is owned or controlled by, or is under common ownership or control with, another person. For purposes of this paragraph, the term “own” means to own an equity interest (or equivalent thereof) of more than ten percent (10%).

**Commission** is defined as the appropriate regulatory agency in each state of BellSouth’s nine-state region (Alabama, Florida, Georgia, Kentucky, Louisiana, Mississippi, North Carolina, South Carolina, and Tennessee).

**Competitive Local Exchange Carrier (CLEC)** means a telephone company certificated by the Commission to provide local exchange service within BellSouth's franchised area.

**Effective Date** is defined as the date that the Agreement is effective for purposes of rates, terms and conditions and shall be thirty (30) days after the date of the last signature executing the Agreement. Future amendments for rate changes will also be effective thirty (30) days after the date of the last signature executing the amendment.

**FCC** means the Federal Communications Commission.

**Telecommunications** means the transmission, between or among points specified by the user, of information of the user's choosing, without change in the form or content of the information as sent and received.

**Telecommunications Service** means the offering of telecommunications for a fee directly to the public, or to such classes of users as to be effectively available directly to the public, regardless of the facilities used.

**Telecommunications Act of 1996 (Act)** means Public Law 104-104 of the United States Congress effective February 8, 1996. The Act amended the Communications Act of 1934 (47 U.S.C. Section 1 et. seq.).

## **1 CLEC Certification**

- 1.1 Smart City Communications agrees to provide BellSouth in writing Smart City Communications's CLEC certification from the Commission for all states covered by this Agreement prior to BellSouth filing this Agreement with the appropriate Commission for approval. Additionally, Smart City Communications shall provide to BellSouth an effective certification to do business issued by the secretary of state or equivalent authority in each state covered by this Agreement.
- 1.2 To the extent Smart City Communications is not certified as a CLEC in each state covered by this Agreement as of the execution hereof, Smart City Communications may not purchase services hereunder in that state. Smart City Communications will notify BellSouth in writing and provide CLEC certification from the Commission when it becomes certified to operate in, as well as an effective certification to do business issued by the secretary of state or equivalent authority for, any other state covered by this Agreement. Upon receipt thereof, BellSouth will file this Agreement in that state, and Smart City Communications may purchase services pursuant to this Agreement in that state, subject to establishing appropriate accounts in the additional state as described in Attachment 7.
- 1.3 Should Smart City Communications's certification in any state be rescinded or otherwise terminated, BellSouth may, at its election, suspend or terminate this

Agreement immediately and all monies owed on all outstanding invoices for services provided in that state shall become due, or BellSouth may refuse to provide services hereunder in that state until certification is reinstated in that state, provided such notification is made prior to expiration of the term of this Agreement. Smart City Communications shall provide an effective certification to do business issued by the secretary of state or equivalent authority in each state covered by this Agreement.

## **2 Term of the Agreement**

- 2.1 The initial term of this Agreement shall be three (3) years, beginning on the Effective Date and shall apply to the BellSouth territory in the state of Florida. Notwithstanding any prior agreement of the Parties, the rates, terms and conditions of this Agreement shall not be applied retroactively prior to the Effective Date.
- 2.2 The Parties agree that by no earlier than two hundred seventy (270) days and no later than one hundred eighty (180) days prior to the expiration of the initial term of this Agreement, the Parties shall commence negotiations for a new agreement to be effective beginning on the expiration date of this Agreement (Subsequent Agreement). If as of the expiration of the initial term of this Agreement, a Subsequent Agreement has not been executed by the Parties, then except as set forth in Sections 2.3.1 and 2.3.2 below, this Agreement shall continue on a month-to-month basis while a Subsequent Agreement is being negotiated. The Parties' rights and obligations with respect to this Agreement after expiration of the initial term shall be as set forth in Section 2.3 below.
- 2.3 If, within one hundred thirty-five (135) days of commencing the negotiation referred to in Section 2.2 above, the Parties are unable to negotiate new terms, conditions and prices for a Subsequent Agreement, either Party may petition the Commission to establish appropriate rates, terms and conditions for the Subsequent Agreement pursuant to 47 U.S.C. § 252.
- 2.3.1 Smart City Communications may request termination of this Agreement only if it is no longer purchasing services pursuant to this Agreement. Except as set forth in Section 2.3.2 below, notwithstanding the foregoing, in the event that as of the date of expiration of the initial term of this Agreement and conversion of this Agreement to a month-to-month term, the Parties have not entered into a Subsequent Agreement and no arbitration proceeding has been filed in accordance with Section 2.3 above, then BellSouth may terminate this Agreement upon sixty (60) days notice to Smart City Communications. In the event that BellSouth terminates this Agreement as provided above, BellSouth shall continue to offer services to Smart City Communications pursuant to the rates, terms and conditions set forth in BellSouth's then current standard interconnection agreement. In the event that BellSouth's standard interconnection agreement becomes effective between the Parties, the Parties may continue to negotiate a Subsequent Agreement.

- 2.3.2 Notwithstanding Section 2.2 above, in the event that as of the expiration of the initial term of this Agreement the Parties have not entered into a Subsequent Agreement and no arbitration proceeding has been filed in accordance with Section 2.3 above and BellSouth is not providing any services under this Agreement as of the date of expiration of the initial term of this Agreement, then this Agreement shall not continue on a month-to-month basis but shall be deemed terminated as of the expiration date hereof.
- 2.4 If, at any time during the term of this Agreement, BellSouth is unable to contact Smart City Communications pursuant to the Notices provision hereof or any other contact information provided by Smart City Communications under this Agreement, and there are no active services being provisioned under this Agreement, then BellSouth may, at its discretion, terminate this Agreement, without any liability whatsoever, upon sending of notification to Smart City Communications pursuant to the Notices section hereof. Furthermore, if after eighteen (18) months following the Effective Date of this Agreement Smart City Communications has no active services pursuant to this Agreement, BellSouth may terminate this Agreement, without any liability to BellSouth, upon notification to Smart City Communications pursuant to the Notices section hereof.
- 2.5 In addition to as otherwise set forth in this Agreement, BellSouth reserves the right to suspend access to ordering systems, refuse to process additional or pending applications for service, or terminate service in the event of prohibited, unlawful or improper use of BellSouth's facilities or service, abuse of BellSouth's facilities or any other material breach of this Agreement, and all monies owed on all outstanding invoices shall become due. In such event, Smart City Communications is solely responsible for notifying its customers of any discontinuance of service.

### **3 Nondiscriminatory Access**

When Smart City Communications purchases Telecommunications Services from BellSouth pursuant to Attachment 1 of this Agreement for the purposes of resale to customers, such services shall be equal in quality, subject to the same conditions, and provided within the same provisioning time intervals that BellSouth provides to others, including its customers. To the extent technically feasible, the quality of a Network Element, as well as the quality of the access to such Network Element provided by BellSouth to Smart City Communications shall be at least equal to that which BellSouth provides to itself and shall be the same for all Telecommunications carriers requesting access to that Network Element. The quality of the interconnection between the network of BellSouth and the network of Smart City Communications shall be at a level that is equal to that which BellSouth provides itself, a subsidiary, an Affiliate, or any other party. The interconnection facilities shall be designed to meet the same technical criteria and service standards that are used within BellSouth's network and shall extend to a consideration of service quality as perceived by BellSouth's customers and service quality as perceived by Smart City Communications.

#### **4 Court Ordered Requests for Call Detail Records and Other Subscriber Information**

- 4.1 Subpoenas Directed to BellSouth. Where BellSouth provides resold services for Smart City Communications, BellSouth shall respond to subpoenas and court ordered requests delivered directly to BellSouth for the purpose of providing call detail records when the targeted telephone numbers belong to Smart City Communications customers. Billing for such requests will be generated by BellSouth and directed to the law enforcement agency initiating the request. BellSouth shall maintain such information for Smart City Communications customers for the same length of time it maintains such information for its own customers.
- 4.2 Subpoenas Directed to Smart City Communications. Where BellSouth is providing resold services to Smart City Communications, , then Smart City Communications agrees that in those cases where Smart City Communications receives subpoenas or court ordered requests regarding targeted telephone numbers belonging to Smart City Communications customers, and where Smart City Communications does not have the requested information, Smart City Communications will advise the law enforcement agency initiating the request to redirect the subpoena or court ordered request to BellSouth for handling in accordance with Section 4.1 above.
- 4.3 In all other instances, where either Party receives a request for information involving the other Party's customer, the Party receiving the request will advise the law enforcement agency initiating the request to redirect such request to the other Party.

#### **5 Liability and Indemnification**

- 5.1 Smart City Communications Liability. In the event that Smart City Communications consists of two (2) or more separate entities as set forth in this Agreement and/or any Amendments hereto, or any third party places orders under this Agreement using Smart City Communications's company codes or identifiers, all such entities shall be jointly and severally liable for the obligations of Smart City Communications under this Agreement.
- 5.2 Liability for Acts or Omissions of Third Parties. BellSouth shall not be liable to Smart City Communications for any act or omission of another entity providing any services to Smart City Communications.
- 5.3 Except for any indemnification obligations of the Parties hereunder, each Party's liability to the other for any loss, cost, claim, injury, liability or expense, including reasonable attorneys' fees relating to or arising out of any cause whatsoever, whether based in contract, negligence or other tort, strict liability or otherwise, relating to the performance of this Agreement, shall not exceed a credit for the actual cost of the services or functions not performed or improperly performed.

Any amounts paid to Smart City Communications pursuant to Attachment 9 hereof shall be credited against any damages otherwise payable to Smart City Communications pursuant to this Agreement.

- 5.3.1 Limitations in Tariffs. A Party may, in its sole discretion, provide in its tariffs and contracts with its customers and third parties that relate to any service, product or function provided or contemplated under this Agreement, that to the maximum extent permitted by Applicable Law, such Party shall not be liable to the customer or third party for (i) any loss relating to or arising out of this Agreement, whether in contract, tort or otherwise, that exceeds the amount such Party would have charged that applicable person for the service, product or function that gave rise to such loss and (ii) consequential damages. To the extent that a Party elects not to place in its tariffs or contracts such limitations of liability, and the other Party incurs a loss as a result thereof, such Party shall, except to the extent caused by the other Party's gross negligence or willful misconduct, indemnify and reimburse the other Party for that portion of the loss that would have been limited had the first Party included in its tariffs and contracts the limitations of liability that such other Party included in its own tariffs at the time of such loss.
- 5.3.2 Neither BellSouth nor Smart City Communications shall be liable for damages to the other Party's terminal location, equipment or customer premises resulting from the furnishing of a service, including, but not limited to, the installation and removal of equipment or associated wiring, except to the extent caused by a Party's negligence or willful misconduct or by a Party's failure to ground properly a local loop after disconnection.
- 5.3.3 Under no circumstance shall a Party be responsible or liable for indirect, incidental, or consequential damages, including, but not limited to, economic loss or lost business or profits, damages arising from the use or performance of equipment or software, or the loss of use of software or equipment, or accessories attached thereto, delay, error, or loss of data. In connection with this limitation of liability, each Party recognizes that the other Party may, from time to time, provide advice, make recommendations, or supply other analyses related to the services or facilities described in this Agreement, and, while each Party shall use diligent efforts in this regard, the Parties acknowledge and agree that this limitation of liability shall apply to provision of such advice, recommendations, and analyses.
- 5.3.4 To the extent any specific provision of this Agreement purports to impose liability, or limitation of liability, on either Party different from or in conflict with the liability or limitation of liability set forth in this Section, then with respect to any facts or circumstances covered by such specific provisions, the liability or limitation of liability contained in such specific provision shall apply.
- 5.4 Indemnification for Certain Claims. Except as otherwise set forth in this Agreement and except to the extent caused by the indemnified Party's gross negligence or willful misconduct, the Party providing services hereunder, its Affiliates and its parent company, shall be indemnified, defended and held harmless

by the Party receiving services hereunder against any claim, loss or damage arising from the receiving Party's use of the services provided under this Agreement pertaining to (1) claims for libel, slander or invasion of privacy arising from the content of the receiving Party's own communications, or (2) any claim, loss or damage claimed by any third party (including, but not limited to, a customer of the Party receiving services) arising from the third party's use or reliance on and arising from the Party receiving services use or reliance on the providing Party's services, actions, duties, or obligations arising out of this Agreement.

- 5.5 Disclaimer. EXCEPT AS SPECIFICALLY PROVIDED TO THE CONTRARY IN THIS AGREEMENT, NEITHER PARTY MAKES ANY REPRESENTATIONS OR WARRANTIES TO THE OTHER PARTY CONCERNING THE SPECIFIC QUALITY OF ANY SERVICES, OR FACILITIES PROVIDED UNDER THIS AGREEMENT. THE PARTIES DISCLAIM, WITHOUT LIMITATION, ANY WARRANTY OR GUARANTEE OF MERCHANTABILITY OR FITNESS FOR A PARTICULAR PURPOSE, ARISING FROM COURSE OF PERFORMANCE, COURSE OF DEALING, OR FROM USAGES OF TRADE.

## 6 Intellectual Property Rights and Indemnification

- 6.1 No License. Except as expressly set forth in Section 6.2 below, no patent, copyright, trademark or other proprietary right is licensed, granted or otherwise transferred by this Agreement. The Parties are strictly prohibited from any use, including but not limited to, in the selling, marketing, promoting or advertising of telecommunications services, of any name, service mark, logo or trademark (collectively, the "Marks") of the other Party. The Marks include those Marks owned directly by a Party or its Affiliate(s) and those Marks that a Party has a legal and valid license to use. The Parties acknowledge that they are separate and distinct and that each provides a separate and distinct service and agree that neither Party may, expressly or impliedly, state, advertise or market that it is or offers the same service as the other Party or engage in any other activity that may result in a likelihood of confusion between its own service and the service of the other Party.
- 6.2 Ownership of Intellectual Property. Any intellectual property that originates from or is developed by a Party shall remain the exclusive property of that Party. Except for a limited, non-assignable, non-exclusive, non-transferable license to use patents or copyrights to the extent necessary for the Parties to use any facilities or equipment (including software) or to receive any service solely as provided under this Agreement, no license in patent, copyright, trademark or trade secret, or other proprietary or intellectual property right, now or hereafter owned, controlled or licensable by a Party, is granted to the other Party. Neither shall it be implied nor arise by estoppel. Any trademark, copyright or other proprietary notices appearing in association with the use of any facilities or equipment (including software) shall remain on the documentation, material, product, service, equipment or software. It is the responsibility of each Party to ensure at no additional cost to the other Party that it has obtained any necessary licenses in relation to intellectual property of



third Parties used in its network that may be required to enable the other Party to use any facilities or equipment (including software), to receive any service, or to perform its respective obligations under this Agreement.

### 6.3 Intellectual Property Remedies

6.3.1 Indemnification. The Party providing a service pursuant to this Agreement will defend the Party receiving such service or data provided as a result of such service against claims of infringement arising solely from the use by the receiving Party of such service in the manner contemplated under this Agreement and will indemnify the receiving Party for any damages awarded based solely on such claims in accordance with Section 5 above.

#### 6.3.2 Claim of Infringement

6.3.2.1 In the event that use of any facilities or equipment (including software), becomes, or in the reasonable judgment of the Party who owns the affected network is likely to become, the subject of a claim, action, suit, or proceeding based on intellectual property infringement, then said Party, promptly and at its sole expense and sole option, but subject to the limitations of liability set forth below, shall:

6.3.2.2 modify or replace the applicable facilities or equipment (including software) while maintaining form and function, or

6.3.2.3 obtain a license sufficient to allow such use to continue.

6.3.2.4 In the event Sections 6.3.2.2 or 6.3.2.3 above are commercially unreasonable, then said Party may terminate, upon reasonable notice, this contract with respect to use of, or services provided through use of, the affected facilities or equipment (including software), but solely to the extent required to avoid the infringement claim.

6.3.3 Exception to Obligations. Neither Party's obligations under this Section shall apply to the extent the infringement is caused by: (i) modification of the facilities or equipment (including software) by the indemnitee; (ii) use by the indemnitee of the facilities or equipment (including software) in combination with equipment or facilities (including software) not provided or authorized by the indemnitor, provided the facilities or equipment (including software) would not be infringing if used alone; (iii) conformance to specifications of the indemnitee which would necessarily result in infringement; or (iv) continued use by the indemnitee of the affected facilities or equipment (including software) after being placed on notice to discontinue use as set forth herein.

6.3.4 Exclusive Remedy. The foregoing shall constitute the Parties' sole and exclusive remedies and obligations with respect to a third party claim of intellectual property infringement arising out of the conduct of business under this Agreement.

6.3.5 Dispute Resolution. Any claim arising under Sections 6.1 and 6.2 above shall be excluded from the dispute resolution procedures set forth in Section 8 below and shall be brought in a court of competent jurisdiction.

## 7 **Proprietary and Confidential Information**

7.1 Proprietary and Confidential Information. It may be necessary for BellSouth and Smart City Communications, each as the “Discloser,” to provide to the other Party, as “Recipient,” certain proprietary and confidential information (including trade secret information) including but not limited to technical, financial, marketing, staffing and business plans and information, strategic information, proposals, request for proposals, specifications, drawings, maps, prices, costs, costing methodologies, procedures, processes, business systems, software programs, techniques, customer account data, call detail records and like information (collectively the “Information”). All such Information conveyed in writing or other tangible form shall be clearly marked with a confidential or proprietary legend. Information conveyed orally by the Discloser to Recipient shall be designated as proprietary and confidential at the time of such oral conveyance, shall be reduced to writing by the Discloser within forty-five (45) days thereafter, and shall be clearly marked with a confidential or proprietary legend.

7.2 Use and Protection of Information. Recipient agrees to protect such Information of the Discloser provided to Recipient from whatever source from distribution, disclosure or dissemination to anyone except employees consultants, contractors and agents of Recipient or its Affiliates with a need to know such Information solely in conjunction with Recipient’s analysis of the Information and for no other purpose except as authorized herein or as otherwise authorized in writing by the Discloser. Recipients may make tangible or electronic copies, notes, summaries or extracts of Information only as necessary for use as authorized herein. All tangible or electronic copies, notes, summaries or extracts must be marked with the same confidential and proprietary notice as appears on the original. Information remains at all times the property of Discloser. Upon Discloser’s request, all or any requested portion of the Information (including, but not limited to, tangible and electronic copies, notes, summaries or extracts of any Information) will be promptly returned to Discloser or destroyed, and Recipient will provide Discloser with written certification stating that such information has been returned or destroyed.

### 7.3 Exceptions

7.3.1 Recipient will not have an obligation to protect any portion of the Information which:

7.3.2 (a) is made publicly available by the Discloser or lawfully by a nonparty to this Agreement; (b) is lawfully obtained by Recipient from any source other than Discloser; (c) is previously known to Recipient without an obligation to keep it

confidential; or (d) is released from the terms of this Agreement by Discloser upon written notice to Recipient.

- 7.4 Recipient agrees to use the Information solely for the purposes of negotiations pursuant to 47 U.S.C. § 251 or in performing its obligations under this Agreement and for no other entity or purpose, except as may be otherwise agreed to in writing by the Parties. Nothing herein shall prohibit Recipient from providing information requested by the FCC or a state regulatory agency with jurisdiction over this matter, or to support a request for arbitration or an allegation of failure to negotiate in good faith.
- 7.5 Recipient agrees not to publish or use the Information for any advertising, sales or marketing promotions, press releases, or publicity matters that refer either directly or indirectly to the Information or to the Discloser or any of its affiliated companies.
- 7.6 The disclosure of Information neither grants nor implies any license to the Recipient under any trademark, patent, copyright, application or other intellectual property right that is now or may hereafter be owned by the Discloser.
- 7.7 Survival of Confidentiality Obligations. The Parties' rights and obligations under this Section 7 shall survive and continue in effect until two (2) years after the expiration or termination date of this Agreement with regard to all Information exchanged during the term of this Agreement. Thereafter, the Parties' rights and obligations hereunder survive and continue in effect with respect to any Information that is a trade secret under applicable law.

## 8 **Resolution of Disputes**

Except as otherwise stated in this Agreement, if any dispute arises as to the interpretation of any provision of this Agreement or as to the proper implementation of this Agreement, the aggrieved Party, if it elects to pursue resolution of the dispute, shall petition the Commission for a resolution of the dispute. However, each Party reserves any rights it may have to seek judicial review of any ruling made by the Commission concerning this Agreement.

## 9 **Taxes**

- 9.1 Definition. For purposes of this Section, the terms "taxes" and "fees" shall include but not be limited to federal, state or local sales, use, excise, gross receipts or other taxes or tax-like fees of whatever nature and however designated (including tariff surcharges and any fees, charges or other payments, contractual or otherwise, for the use of public streets or rights of way, whether designated as franchise fees or otherwise) imposed, or sought to be imposed, on or with respect to the services furnished hereunder or measured by the charges or payments therefor, excluding any taxes levied on income.

9.2 Taxes and Fees Imposed Directly On Either Providing Party or Purchasing Party

9.2.1 Taxes and fees imposed on the providing Party, which are not permitted or required to be passed on by the providing Party to its customer, shall be borne and paid by the providing Party.

9.2.2 Taxes and fees imposed on the purchasing Party, which are not required to be collected and/or remitted by the providing Party, shall be borne and paid by the purchasing Party.

9.3 Taxes and Fees Imposed on Purchasing Party But Collected And Remitted By Providing Party

9.3.1 Taxes and fees imposed on the purchasing Party shall be borne by the purchasing Party, even if the obligation to collect and/or remit such taxes or fees is placed on the providing Party.

9.3.2 To the extent permitted by applicable law, any such taxes and/or fees shall be shown on applicable billing documents between the Parties. Notwithstanding the foregoing, the purchasing Party shall remain liable for any such taxes and fees regardless of whether they are actually billed by the providing Party at the time that the respective service is billed.

9.3.3 If the purchasing Party determines that in its opinion any such taxes or fees are not applicable, the providing Party shall not bill such taxes or fees to the purchasing Party if the purchasing Party provides written certification, reasonably satisfactory to the providing Party, stating that it is exempt or otherwise not subject to the tax or fee, setting forth the basis therefor, and satisfying any other requirements under applicable law. If any authority seeks to collect any such tax or fee that the purchasing Party has determined and certified not to be applicable, or any such tax or fee that was not billed by the providing Party, the purchasing Party may contest the same in good faith, at its own expense. In any such contest, the purchasing Party shall promptly furnish the providing Party with copies of all filings in any proceeding, protest, or legal challenge, all rulings issued in connection therewith, and all correspondence between the purchasing Party and the taxing authority.

9.3.4 In the event that all or any portion of an amount sought to be collected must be paid in order to contest the imposition of any such tax or fee, or to avoid the existence of a lien on the assets of the providing Party during the pendency of such contest, the purchasing Party shall be responsible for such payment and shall be entitled to the benefit of any refund or recovery. The purchasing Party shall have the right to contest, at its own expense, any such tax or fee that it believes is not applicable or was paid by it in error. If requested in writing by the purchasing Party, the providing Party shall facilitate such contest either by assigning to the purchasing Party its right to claim a refund of such tax or fee, if such an assignment is permitted under applicable law, or, if an assignment is not permitted,

by filing and pursuing a claim for refund on behalf of the purchasing Party but at the purchasing Party's expense.

9.3.5 If it is ultimately determined that any additional amount of such a tax or fee is due to the imposing authority, the purchasing Party shall pay such additional amount, including any interest and penalties thereon.

9.3.6 Notwithstanding any provision to the contrary, the purchasing Party shall protect, indemnify and hold harmless (and defend at the purchasing Party's expense) the providing Party from and against any such tax or fee, interest or penalties thereon, or other charges or payable expenses (including reasonable attorney fees) with respect thereto, which are incurred by the providing Party in connection with any claim for or contest of any such tax or fee.

9.3.7 Each Party shall notify the other Party in writing of any assessment, proposed assessment or other claim for any additional amount of such a tax or fee by a taxing authority; provided, however, that the failure of a Party to provide notice shall not relieve the other Party of any obligations hereunder.

9.4 Taxes and Fees Imposed on Providing Party But Passed On To Purchasing Party

9.4.1 Taxes and fees imposed on the providing Party, which are permitted or required to be passed on by the providing Party to its customer, shall be borne by the purchasing Party.

9.4.2 To the extent permitted by applicable law, any such taxes and/or fees shall be shown on applicable billing documents between the Parties. Notwithstanding the foregoing, the purchasing Party shall remain liable for any such taxes and fees regardless of whether they are actually billed by the providing Party at the time that the respective service is billed.

9.4.3 If the purchasing Party disagrees with the providing Party's determination as to the application of or basis for any such tax or fee, the Parties shall consult with respect to the imposition and billing of such tax or fee. Notwithstanding the foregoing, the providing Party shall retain ultimate responsibility for determining whether and to what extent any such taxes or fees are applicable, and the purchasing Party shall abide by such determination and pay such taxes or fees to the providing Party. The providing Party shall further retain ultimate responsibility for determining whether and how to contest the imposition of such taxes and fees; provided, however, that any such contest undertaken at the request of the purchasing Party shall be at the purchasing Party's expense.

9.4.4 In the event that all or any portion of an amount sought to be collected must be paid in order to contest the imposition of any such tax or fee, or to avoid the existence of a lien on the assets of the providing Party during the pendency of such contest, the purchasing Party shall be responsible for such payment and shall be entitled to the benefit of any refund or recovery. The purchasing Party shall have

the right to contest, at its own expense, any such tax or fee that it believes is not applicable or was paid by it in error. If requested in writing by the purchasing Party, the providing Party shall facilitate such contest either by assigning to the purchasing Party its right to claim a refund of such tax or fee, if such an assignment is permitted under applicable law, or, if an assignment is not permitted, by filing and pursuing a claim for refund on behalf of the purchasing Party but at the purchasing Party's expense.

9.4.5 If it is ultimately determined that any additional amount of such a tax or fee is due to the imposing authority, the purchasing Party shall pay such additional amount, including any interest and penalties thereon.

9.4.6 Notwithstanding any provision to the contrary, the purchasing Party shall protect, indemnify and hold harmless (and defend at the purchasing Party's expense) the providing Party from and against any such tax or fee, interest or penalties thereon, or other charges or payable expenses (including reasonable attorneys' fees) with respect thereto, which are incurred by the providing Party in connection with any claim for or contest of any such tax or fee.

9.4.7 Each Party shall notify the other Party in writing of any assessment, proposed assessment or other claim for any additional amount of such a tax or fee by a taxing authority; provided, however, that the failure of a Party to provide notice shall not relieve the other Party of any obligations hereunder.

#### 9.5 Additional Provisions Applicable to All Taxes and Fees

9.5.1 In any contest of a tax or fee by one Party, the other Party shall cooperate fully by providing records, testimony and such additional information or assistance as may reasonably be necessary to pursue the contest. Further, the other Party shall be reimbursed for any reasonable and necessary out-of-pocket copying and travel expenses incurred in assisting in such contest.

9.5.2 Notwithstanding any provision of this Agreement to the contrary, any administrative, judicial, or other proceeding concerning the application or amount of a tax or fee shall be maintained in accordance with the provisions of this Section and any applicable federal, state or local law governing the resolution of such disputed tax or fee; and under no circumstances shall either Party have the right to bring a dispute related to the application or amount of a tax or fee before a regulatory authority.

## 10 **Force Majeure**

In the event performance of this Agreement, or any obligation hereunder, is either directly or indirectly prevented, restricted, or interfered with by reason of fire, flood, earthquake or like acts of God, wars, revolution, civil commotion, explosion, acts of public enemy, embargo, acts of the government in its sovereign capacity, labor difficulties, including without limitation, strikes, slowdowns, picketing, or boycotts, unavailability of equipment from vendor, changes requested

by Smart City Communications, or any other circumstances beyond the reasonable control and without the fault or negligence of the Party affected, the Party affected shall be excused from such performance on a day-to-day basis to the extent of such prevention, restriction, or interference (and the other Party shall likewise be excused from performance of its obligations on a day-to-day basis until the delay, restriction or interference has ceased); provided, however, that the Party so affected shall use diligent efforts to avoid or remove such causes of non-performance and both Parties shall proceed whenever such causes are removed or cease. The Party affected shall provide notice of the Force Majeure event within a reasonable period of time following such an event.

## **11 Adoption of Agreements**

Pursuant to 47 U.S.C. § 252(i) and 47 C.F.R. § 51.809, BellSouth shall make available to Smart City Communications any entire interconnection agreement filed and approved pursuant to 47 U.S.C. § 252. The adopted agreement shall apply to the same states as the agreement that was adopted, and the term of the adopted agreement shall expire on the same date as set forth in the agreement that was adopted.

## **12 Modification of Agreement**

- 12.1 If Smart City Communications changes its name or makes changes to its company structure or identity due to a merger, acquisition, transfer or any other reason, it is the responsibility of Smart City Communications to notify BellSouth of said change, request that an amendment to this Agreement, if necessary, be executed to reflect said change and notify the Commission of such modification of company structure in accordance with the state rules governing such modification in company structure if applicable. Additionally, Smart City Communications shall provide BellSouth with any necessary supporting documentation, which may include, but is not limited to, a credit application, Application for Master Account, proof of authority to provide telecommunications services, the appropriate Operating Company Number (OCN) for each state as assigned by National Exchange Carrier Association (NECA), Carrier Identification Code (CIC), Access Customer Name and Abbreviation (ACNA), BellSouth's blanket form letter of authority (LOA), Misdirected Number form and a tax exemption certificate.
- 12.2 No modification, amendment, supplement to, or waiver of the Agreement or any of its provisions shall be effective and binding upon the Parties unless it is made in writing and duly signed by the Parties.
- 12.3 In the event that any effective legislative, regulatory, judicial or other legal action materially affects any material terms of this Agreement, or the ability of Smart City Communications or BellSouth to perform any material terms of this Agreement, Smart City Communications or BellSouth may, on thirty (30) days' written notice, require that such terms be renegotiated, and the Parties shall renegotiate in good faith such mutually acceptable new terms as may be required. In the event that such new terms are not renegotiated within forty-five (45) days after such notice,

and either Party elects to pursue resolution of such amendment such Party shall pursue the dispute resolution process set forth in Section 8 above.

**13 Legal Rights**

Execution of this Agreement by either Party does not confirm or imply that the executing Party agrees with any decision(s) issued pursuant to the Telecommunications Act of 1996 and the consequences of those decisions on specific language in this Agreement. Neither Party waives its rights to appeal or otherwise challenge any such decision(s) and each Party reserves all of its rights to pursue any and all legal and/or equitable remedies, including appeals of any such decision(s).

**14 Indivisibility**

Subject to Section 15 below, the Parties intend that this Agreement be indivisible and nonseverable, and each of the Parties acknowledges that it has assented to all of the covenants and promises in this Agreement as a single whole and that all of such covenants and promises, taken as a whole, constitute the essence of the contract. Without limiting the generality of the foregoing, each of the Parties acknowledges that any provision by BellSouth of collocation space under this Agreement is solely for the purpose of facilitating the provision of other services under this Agreement as set forth in Attachment 4. The Parties further acknowledge that this Agreement is intended to constitute a single transaction and that the obligations of the Parties under this Agreement are interdependent.

**15 Severability**

If any provision of this Agreement, or part thereof, shall be held invalid or unenforceable in any respect, the remainder of the Agreement or provision shall not be affected thereby, provided that the Parties shall negotiate in good faith to reformulate such invalid provision, or part thereof, or related provision, to reflect as closely as possible the original intent of the parties, consistent with applicable law, and to effectuate such portions thereof as may be valid without defeating the intent of such provision. In the event the Parties are unable to mutually negotiate such replacement language, either Party may elect to pursue the dispute resolution process set forth in Section 8 above.

**16 Non-Waivers**

A failure or delay of either Party to enforce any of the provisions hereof, to exercise any option which is herein provided, or to require performance of any of the provisions hereof shall in no way be construed to be a waiver of such provisions or options, and each Party, notwithstanding such failure, shall have the right thereafter to insist upon the performance of any and all of the provisions of this Agreement.

**17 Governing Law**

Where applicable, this Agreement shall be governed by and construed in accordance with federal and state substantive telecommunications law, including rules and regulations of the FCC and appropriate Commission. In all other



respects, this Agreement shall be governed by and construed and enforced in accordance with the laws of the State of Georgia without regard to its conflict of laws principles.

## **18 Assignments and Transfers**

18.1 Any assignment by either Party to any entity of any right, obligation or duty, or of any other interest hereunder, in whole or in part, without the prior written consent of the other Party shall be void. The assignee must provide evidence of a Commission approved certification to provide Telecommunications Service in each state that Smart City Communications is entitled to provide Telecommunications Service. After BellSouth's consent, the Parties shall amend this Agreement to reflect such assignments and shall work cooperatively to implement any changes required due to such assignment. All obligations and duties of any Party under this Agreement shall be binding on all successors in interest and assigns of such Party. No assignment or delegation hereof shall relieve the assignor of its obligations under this Agreement in the event that the assignee fails to perform such obligations. Notwithstanding anything to the contrary in this Section, Smart City Communications shall not be permitted to assign this Agreement in whole or in part to any entity unless either (1) Smart City Communications pays all bills, past due and current, under this Agreement, or (2) Smart City Communications's assignee expressly assumes liability for payment of such bills.

18.2 In the event that Smart City Communications desires to transfer any services hereunder to another provider of Telecommunications Service, or Smart City Communications desires to assume hereunder any services provisioned by BellSouth to another provider of Telecommunications Service, such transfer of services shall be subject to separately negotiated rates, terms and conditions.

## **19 Notices**

19.1 Every notice, consent or approval of a legal nature, required or permitted by this Agreement shall be in writing and shall be delivered either by hand, by overnight courier or by US mail postage prepaid, or email if an email address is listed below, addressed to:

### **BellSouth Telecommunications, Inc.**

BellSouth Local Contract Manager  
600 North 19<sup>th</sup> Street, 10<sup>th</sup> floor  
Birmingham, AL 35203

and

Business Markets Attorney  
Suite 4300  
675 West Peachtree Street  
Atlanta, GA 30375

**Smart City Solutions, LLC d/b/a Smart City Communications**

Lynn B. Hall  
Smart City Communications  
P. O. Box 22856  
Lake Buena Vista, FL 32830-2856  
lbhall@smartcity.com  
407.828.6730  
407.828.6734 (fax)

or at such other address as the intended recipient previously shall have designated by written notice to the other Party.

19.2 Unless otherwise provided in this Agreement, notice by mail shall be effective on the date it is officially recorded as delivered by return receipt or equivalent, and in the absence of such record of delivery, it shall be presumed to have been delivered the fifth day, or next business day after the fifth day, after it was deposited in the mails.

19.3 Notwithstanding the above, BellSouth will post to BellSouth's Interconnection Web site changes to business processes and policies and shall post to BellSouth's Interconnection Web site or submit through applicable electronic systems, other service and business related notices not requiring an amendment to this Agreement.

**20 Rule of Construction**

No rule of construction requiring interpretation against the drafting Party hereof shall apply in the interpretation of this Agreement.

**21 Headings of No Force or Effect**

The headings of Articles and Sections of this Agreement are for convenience of reference only, and shall in no way define, modify or restrict the meaning or interpretation of the terms or provisions of this Agreement.

**22 Multiple Counterparts**

This Agreement may be executed in multiple counterparts, each of which shall be deemed an original, but all of which shall together constitute but one and the same document.

**23 Filing of Agreement**

This Agreement, and any amendments hereto, shall be filed with the appropriate state regulatory agency pursuant to the requirements of Section 252 of the Act, or

as otherwise required by the state and the Parties shall share equally in any applicable fees. Notwithstanding the foregoing, this Agreement shall not be submitted for approval by the appropriate state regulatory agency unless and until such time as Smart City Communications is duly certified as a local exchange carrier in such state, except as otherwise required by a Commission.

**24 Compliance with Law**

The Parties have negotiated their respective rights and obligations pursuant to substantive Federal and State Telecommunications law and this Agreement is intended to memorialize the Parties' mutual agreement with respect to each Party's rights and obligations under the Act and applicable FCC and Commission orders, rules and regulations. Nothing contained herein, nor any reference to applicable rules and orders, is intended to expand on the Parties' rights and obligations as set forth herein. This Agreement also contains certain provisions that were negotiated without regard to the Parties' obligations as set forth Section 251 of the Act. To the extent the provisions of this Agreement differ from the provisions of any Federal or State Telecommunications statute, rule or order in effect as of the execution of this Agreement, this Agreement shall control. Each Party shall comply at its own expense with all other laws of general applicability.

**25 Necessary Approvals**

Each Party shall be responsible for obtaining and keeping in effect all approvals from, and rights granted by, governmental authorities, building and property owners, other carriers, and any other persons that may be required in connection with the performance of its obligations under this Agreement. Each Party shall reasonably cooperate with the other Party in obtaining and maintaining any required approvals and rights for which such Party is responsible.

**26 Good Faith Performance**

Each Party shall act in good faith in its performance under this Agreement and, in each case in which a Party's consent or agreement is required or requested hereunder, such Party shall not unreasonably withhold or delay such consent or agreement.

**27 Rates**

27.1 Smart City Communications shall pay the charges set forth in this Agreement. In the event that BellSouth is unable to bill the applicable rate or no rate is established or included in this Agreement for any services provided pursuant to this Agreement, BellSouth reserves the right to back bill Smart City Communications for such rate or for the difference between the rate actually billed and the rate that should have been billed pursuant to this Agreement; provided, however, that subject to Smart City Communications's agreement to the limitation regarding billing disputes as described in Section 2.2 of Attachment 7 hereof, BellSouth shall not back bill any amounts for services rendered more than twelve (12) months prior to the date that the charges or additional charges for such services are actually billed. Notwithstanding the foregoing, both Parties recognize that

situations may exist which could necessitate back billing beyond twelve (12) months. These exceptions are:

- Charges connected with jointly provided services whereby meet point billing guidelines require either Party to rely on records provided by a third party and such records have not been provided in a timely manner;
- Charges incorrectly billed due to erroneous information supplied by the non-billing Party;
- Charges for which a regulatory body has granted, or a regulatory change permits, the billing Party the authority to back bill.

27.2 To the extent a rate element is omitted or no rate is established, BellSouth has the right not to provision such service until the Agreement is amended to include such rate.

27.3 To the extent Smart City Communications requests services not included in this Agreement, such services shall be provisioned pursuant to the rates, terms and conditions set forth in the applicable tariffs or a separately negotiated Agreement, unless the Parties agree to amend this Agreement to include such service prospectively.

## **28 Rate True-Up**

28.1 This section applies to rates that are expressly subject to true-up.

28.2 The rates shall be trued-up, either up or down, based on final prices determined either by further agreement between the Parties, or by a final and effective order of the Commission. The Parties shall implement the true-up by comparing the actual volumes and demand for each item, together with the rates for each item, with the final prices determined for each item. Each Party shall keep its own records upon which the true-up can be based, and any final payment from one Party to the other shall be in an amount agreed upon by the Parties based on such records. In the event of any discrepancy between the records or disagreement between the Parties regarding the amount of such true-up, the dispute shall be subject to the dispute resolution process set forth in this Agreement.

28.3 A final and effective order of the Commission that forms the basis of a true-up shall be based upon cost studies submitted by either or both Parties to the Commission and shall be binding upon BellSouth and Smart City Communications specifically or upon all carriers generally, such as a generic cost proceeding.

**29 Survival**

The Parties' obligations under this Agreement which by their nature are intended to continue beyond the termination or expiration of this Agreement shall survive the termination or expiration of this Agreement.

**30 Entire Agreement**

30.1 This Agreement means the General Terms and Conditions, the Attachments hereto and all documents identified therein, as such may be amended from time to time and which are incorporated herein by reference, all of which, when taken together, are intended to constitute one indivisible agreement. This Agreement sets forth the entire understanding and supersedes prior agreements between the Parties relating to the subject matter contained in this Agreement and merges all prior discussions between them. Any orders placed under prior agreements between the Parties shall be governed by the terms of this Agreement and Smart City Communications acknowledges and agrees that any and all amounts and obligations owed for services provisioned or orders placed under prior agreements between the Parties, related to the subject matter hereof, shall, as of the Effective Date, be due and owing under this Agreement and be governed by the terms and conditions of this Agreement as if such services or orders were provisioned or placed under this Agreement. Neither Party shall be bound by any definition, condition, provision, representation, warranty, covenant or promise other than as expressly stated in this Agreement or as is contemporaneously or subsequently set forth in writing and executed by a duly authorized officer or representative of the Party to be bound thereby.

30.2 Any reference throughout this Agreement to a tariff, industry guideline, BellSouth's technical guideline or reference, BellSouth business rule, guide or other such document containing processes or specifications applicable to the services provided pursuant to this Agreement, shall be construed to refer to only those provisions thereof that are applicable to these services, and shall include any successor or replacement versions thereof, all as they are amended from time to time and all of which are incorporated herein by reference, and may be found at BellSouth's Interconnection Web site at: [www.interconnection.bellsouth.com](http://www.interconnection.bellsouth.com). References to state tariffs throughout this Agreement shall be to the tariff for the state in which the services were provisioned; provided, however, that in any state where certain BellSouth services or tariff provisions have been or become deregulated or detariffed, any reference in this Agreement to a detariffed or deregulated service or provision of such tariff shall be deemed to refer to the service description, price list or other agreement pursuant to which BellSouth provides such services as a result of detariffing or deregulation.

General Terms and Conditions  
Signature Page

IN WITNESS WHEREOF, the Parties have executed this Agreement the day and year written below.

**BellSouth Telecommunications, Inc.**

By: 

Name: Kristen E. Shore

Title: Director

Date: 3/9/07

**Smart City Solutions, LLC d/b/a  
Smart City Communications**

By: 

Name: James T. Schumacher

Title: Vice President - Finance

Date: March 8, 2007

## **Attachment 1**

### **Resale**

**Table of Contents**

**1. Discount Rates.....3**

**2. Definition of Terms .....3**

**3. General Provisions .....3**

**4 BellSouth’s Provision of Services to Smart City Communications .....6**

**5. Maintenance of Services.....7**

**6. Discontinuance of Service .....7**

**7. White Pages Listings .....8**

**8. Operator Services (Operator Call Processing and Directory Assistance).....10**

**9. Branding for Wholesale OCP and DA .....11**

**10. LIDB .....12**

**11. Revenue Accounting Office (RAO) Hosting.....12**

**12. Optional Daily Usage File (ODUF).....12**

**13. Enhanced Optional Daily Usage File (EODUF) .....13**

**Resale Restrictions .....Exhibit A**

**Optional Daily Usage File (ODUF).....Exhibit B**

**Enhanced Option Daily Usage File (EODUF).....Exhibit C**

**Resale Discounts and Rates .....Exhibit D**



## RESALE

### 1. Discount Rates

1.1 The discounts rates applied to Smart City Communications's purchases of BellSouth Telecommunications Services for the purpose of resale shall be as set forth in Exhibit D. Such discounts have been determined by the applicable Commission to reflect the costs avoided by BellSouth when selling a service for wholesale purposes.

1.2 The Telecommunications Services available for purchase by Smart City Communications for the purposes of resale to Smart City Communications's customers shall be available at BellSouth's tariffed rates less the discount reflected in Exhibit D and subject to the exclusions and limitations in Exhibit A.

### 2. Definition of Terms

For purposes of this Attachment only, the following terms shall have the definitions as set forth below:

2.1 Customer of Record means the entity responsible for placing application for service; requesting additions, rearrangements, maintenance or discontinuance of service; payment in full of charges incurred such as nonrecurring, monthly recurring, toll, directory assistance, etc.

2.2 End User Customer Location means the physical location of the premises where a customer makes use of the Telecommunications Services.

2.3 New Services means functions, features or capabilities that are not currently offered by BellSouth. This includes packaging of existing services or combining a new function, feature or capability with an existing service.

2.4 Resale means an activity wherein a certificated CLEC, such as Smart City Communications, subscribes to the retail Telecommunications Services of BellSouth and then offers those retail Telecommunications Services to the public.

### 3. General Provisions

3.1 All of the negotiated rates, terms and conditions set forth in this Attachment pertain to the resale of BellSouth's retail Telecommunications Services and other services specified in this Attachment. Subject to effective and applicable FCC and Commission rules and orders, BellSouth shall make available to Smart City Communications for resale those Telecommunications Services BellSouth makes available, pursuant to its General Subscriber Services Tariff (GSST) and Private Line Services Tariff, to customers who are not Telecommunications carriers.

3.1.1 When Smart City Communications provides Resale service in a cross boundary area (customer is physically located in a particular state and is served by a central office in an adjoining state) the rates, regulations and discounts for the state in which the serving central office is located will apply. Billing will be from the state in which the customer is located.

- 3.2 Smart City Communications as a reseller of Lifeline and Link-Up Services hereby certifies that it has and will comply with the FCC requirements governing the Lifeline and Link-Up programs as set forth in 47 C.F.R. § 54.417(a) and (b). This includes the requirements set forth in BellSouth's GSST, Sections A3.31 and A4.7.
- 3.2.1 Smart City Communications shall maintain records to document FCC or applicable state eligibility and verification records to document compliance governing the Lifeline/Link-Up programs for the three (3) full preceding calendar years, and Smart City Communications shall provide such documentation to the FCC or its Administrator upon request.
- 3.3 Smart City Communications may purchase resale services from BellSouth for its own use in operating its business. The resale discount will apply to those services under the following conditions:
- 3.3.1 Smart City Communications must resell services to other end users.
- 3.3.2 Smart City Communications cannot be a CLEC for the single purpose of selling to itself.
- 3.3.3 Smart City Communications will be the Customer of Record for all services purchased from BellSouth. Except as specified herein, BellSouth will take orders from, bill and receive payment from Smart City Communications for said services.
- 3.4 Smart City Communications will be BellSouth's single point of contact for all services purchased pursuant to this Agreement. BellSouth shall have no contact with the customer except to the extent provided for herein.
- 3.5 BellSouth will continue to bill the customer for any services that the customer specifies it wishes to receive directly from BellSouth. BellSouth maintains the right to serve directly any customer within the service area of Smart City Communications. BellSouth will continue to market directly its own Telecommunications products and services and in doing so may establish independent relationships with customers of Smart City Communications. Neither Party shall interfere with the right of any person or entity to obtain service directly from the other Party.
- 3.5.1 BellSouth will accept a request from another CLEC for conversion of the customer's service from Smart City Communications to such other CLEC. Upon completion of the conversion BellSouth will notify Smart City Communications that such conversion has been completed.
- 3.5.2 When a customer of Smart City Communications or BellSouth elects to change his/her carrier to the other Party, both Parties agree to release the customer's service to the other Party concurrent with the due date of the service order, which shall be established based on the standard interval for the customer's requested service as set forth in the BellSouth Product and Services Interval Guide.
- 3.5.3 BellSouth and Smart City Communications will refrain from contacting a customer who has placed or whose selected carrier has placed on the customer's

behalf an order to change the customer's service provider from BellSouth or Smart City Communications to the other Party until such time that the order for service has been completed.

- 3.6 Current telephone numbers may normally be retained by the customer and are assigned to the service furnished. However, neither Party nor the customer has a property right to the telephone number or any other call number designation associated with services furnished by BellSouth, and no right to the continuance of service through any particular central office. BellSouth reserves the right to change such numbers, or the central office designation associated with such numbers, or both, whenever BellSouth deems it necessary to do so in the conduct of its business and in accordance with BellSouth practices and procedures on a nondiscriminatory basis.
- 3.7 Service is furnished subject to the condition that it will not be used for any unlawful purpose.
- 3.8 Service will be discontinued if any law enforcement agency advises that the service being used is in violation of the law.
- 3.9 BellSouth can refuse service when it has grounds to believe that service will be used in violation of the law.
- 3.10 If Smart City Communications or its customers utilize a BellSouth resold Telecommunications Service in a manner other than that for which the service was originally intended as described in BellSouth's retail tariffs Smart City Communications has the responsibility to notify BellSouth. BellSouth will only provision and maintain said service consistent with the terms and conditions of the tariff describing said service.
- 3.11 Facilities and/or equipment utilized by BellSouth to provide service to Smart City Communications remain the property of BellSouth.
- 3.12 Service Ordering and Operations Support Systems (OSS)
- 3.12.1 Smart City Communications must order services through resale interfaces, i.e., the Local Carrier Service Center (LCSC) and/or appropriate Complex Resale Support Group (CRSG) pursuant to this Agreement. Smart City Communications may submit a Local Service Request (LSR) electronically as set forth in Attachment 6. Service orders will be in a standard format designated by BellSouth.
- 3.12.2 BellSouth messaging services set forth in BellSouth's Messaging Service Re-Seller Information Package shall be made available for resale without the wholesale discount.
- 3.13 BellSouth's Inside Wire Maintenance Service Plan is available for resale at rates, terms and conditions as set forth by BellSouth and without the wholesale discount.
- 3.14 In the event Smart City Communications acquires a customer whose service is provided pursuant to a BellSouth Special Assembly, BellSouth shall make available to Smart City Communications that Special Assembly at the wholesale discount at Smart City Communications's option. Smart City Communications

shall be responsible for all terms and conditions of such Special Assembly including but not limited to termination liability if applicable.

- 3.15 BellSouth shall provide 911/E911 for Smart City Communications customers in the same manner that it is provided to BellSouth customers. BellSouth shall provide and validate Smart City Communications customer information to the Public Safety Answering Point (PSAP). BellSouth shall use its service order process to update and maintain, on the same schedule that it uses for its customers, the Smart City Communications customer information in the Automatic Location Identification/Data Management System (ALI/DMS) databases used to support 911/E911 services.
- 3.16 Pursuant to 47 C.F.R. § 51.617, BellSouth shall bill to Smart City Communications, and Smart City Communications shall pay, the End User Common Line (EUCL) charges identical to the EUCL charges BellSouth bills its customers.
- 4 BellSouth's Provision of Services to Smart City Communications**
- 4.1 Resale of BellSouth services shall be as follows:
- 4.1.1 The resale of Telecommunications Services shall be limited to users and uses conforming to the class of service restrictions.
- 4.1.2 Hotel and Hospital PBX services are the only Telecommunications Services available for resale to Hotel/Motel and Hospital customers, respectively. Similarly, Access Line Service for Customer Provided Coin Telephones is the only local service available for resale to Payphone Service Provider (PSP) customers. Shared Tenant Service customers can only be sold those local exchange access services available in BellSouth's GSST Section A23, Shared Tenant Service Section in the state of Florida.
- 4.1.3 BellSouth reserves the right to periodically audit services purchased by Smart City Communications to establish authenticity of use. Such audit shall not occur more than once in a calendar year. Smart City Communications shall make any and all records and data available to BellSouth or BellSouth's auditors on a reasonable basis. BellSouth shall bear the cost of said audit. Any information provided by Smart City Communications for purposes of such audit shall be deemed Confidential Information pursuant to the General Terms and Conditions.
- 4.2 Subject to Exhibit A hereto, resold services can only be used in the same manner as specified in BellSouth's Tariffs. Resold services are subject to the same terms and conditions as are specified for such services when furnished to an individual customer of BellSouth in the appropriate section of BellSouth's Tariffs. Specific tariff features (e.g., a usage allowance per month) shall not be aggregated across multiple resold services.
- 4.3 If Smart City Communications cancels an order for resold services, any costs incurred by BellSouth in conjunction with provisioning of such order will be recovered in accordance with BellSouth's GSST and Private Line Services Tariffs.

- 4.4 Service Jointly Provisioned with an Independent Company or CLEC
- 4.4.1 BellSouth will in some instances provision resold services in accordance with BellSouth's GSST and Private Line Tariffs jointly with an Independent Company (ICO) or other CLEC.
- 4.4.2 When Smart City Communications assumes responsibility for such service, all terms and conditions defined in the Tariff will apply for services provided within the BellSouth service area only.
- 4.4.3 Service terminating in an ICO or other CLEC area will be provisioned and billed by the ICO or other CLEC directly to Smart City Communications.
- 4.4.4 Smart City Communications must establish a billing arrangement with the ICO or other CLEC prior to assuming a customer account where such circumstances apply.
- 4.4.5 Specific guidelines regarding such services are available on the BellSouth Interconnection Web site.
- 5. Maintenance of Services**
- 5.1 Services resold pursuant to this Attachment and BellSouth's GSST and Private Line Service Tariff and facilities and equipment provided by BellSouth shall be maintained by BellSouth.
- 5.2 Smart City Communications or its customers may not rearrange, move, disconnect, remove or attempt to repair any facilities owned by BellSouth except with the written consent of BellSouth.
- 5.3 Smart City Communications accepts responsibility to notify BellSouth of situations that arise that may result in a service problem.
- 5.4 Smart City Communications will contact the appropriate repair centers in accordance with procedures established by BellSouth.
- 5.5 For all repair requests, Smart City Communications shall adhere to BellSouth's prescreening guidelines prior to referring the trouble to BellSouth.
- 5.6 BellSouth reserves the right to contact Smart City Communications's customers, if deemed necessary, for maintenance purposes.
- 6. Discontinuance of Service**
- 6.1 The procedures for discontinuing service to a customer are as follows:
- 6.1.1 BellSouth will deny service to Smart City Communications's customer on behalf of, and at the request of, Smart City Communications. Upon restoration of the customer's service, restoral charges will apply and will be the responsibility of Smart City Communications.
- 6.1.2 At the request of Smart City Communications, BellSouth will disconnect a Smart City Communications customer.
- 6.1.3 All requests by Smart City Communications for denial or disconnection of a customer for nonpayment must be in writing.

- 6.1.4 Smart City Communications will be made solely responsible for notifying the customer of the proposed disconnection of the service.
- 6.1.5 BellSouth will continue to process calls made to the Annoyance Call Center and will advise Smart City Communications when it is determined that annoyance calls are originated from one of its customer's locations. BellSouth shall be indemnified, defended and held harmless by Smart City Communications and/or the customer against any claim, loss or damage arising from providing this information to Smart City Communications. It is the responsibility of Smart City Communications to take the corrective action necessary with its customer who make annoying calls. (Failure to do so will result in BellSouth's disconnecting the customer's service.)
- 7. White Pages Listings**
- 7.1 BellSouth shall provide Smart City Communications and its end users access to white pages directory listings under the following terms:
- 7.1.1 Listings. Smart City Communications shall provide all new, changed and deleted listings on a timely basis and BellSouth or its agent will include Smart City Communications residential and business customer listings in the appropriate White Pages (residential and business) or alphabetical directories in the geographic areas covered by this Agreement. Directory listings will make no distinction between Smart City Communications and BellSouth customers. Smart City Communications shall provide listing information in accordance with the procedures set forth in The BellSouth Business Rules for Local Ordering found at BellSouth's Interconnection Services Web site.
- 7.1.2 Unlisted/Non-Published Customers. Smart City Communications will be required to provide to BellSouth the names, addresses and telephone numbers of all Smart City Communications customers who wish to be omitted from directories. Unlisted/Non-Published listings will be subject to the rates as set forth in BellSouth's GSST and shall not be subject to the wholesale discount.
- 7.1.3 Inclusion of Smart City Communications Customers in Directory Assistance Database. BellSouth will include and maintain Smart City Communications customer listings in BellSouth's Directory Assistance databases. Smart City Communications shall provide such Directory Assistance listings to BellSouth at no charge.
- 7.1.4 Listing Information Confidentiality. BellSouth will afford Smart City Communications's directory listing information the same level of confidentiality that BellSouth affords its own directory listing information.
- 7.1.5 Additional and Designer Listings. Additional and designer listings will be offered by BellSouth at tariffed rates as set forth in BellSouth's GSST and shall not be subject to the wholesale discount.
- 7.1.6 Rates. So long as Smart City Communications provides listing information to BellSouth as set forth in Section 7.1.2 above, BellSouth shall provide to Smart City Communications one (1) basic White Pages directory listing per Smart City Communications customer at no charge other than the manual service order

charge or the electronic service order charge, as appropriate, as described in Attachment 6.

- 7.2 Directories. BellSouth or its agent shall make available White Pages directories to Smart City Communications customer at no charge or as specified in a separate agreement between Smart City Communications and BellSouth's agent.
- 7.3 Procedures for submitting Smart City Communications Subscriber Listing Information (SLI) are found in The BellSouth Business Rules for Local Ordering found at BellSouth's Interconnection Services Web site.
- 7.3.1 Smart City Communications authorizes BellSouth to release all Smart City Communications SLI provided to BellSouth by Smart City Communications to qualifying third parties pursuant to either a license agreement or BellSouth's Directory Publishers Database Service (DPDS) in BellSouth's GSST. Such Smart City Communications SLI shall be intermingled with BellSouth's own customer listings and listings of any other CLEC that has authorized a similar release of SLI.
- 7.3.2 No compensation shall be paid to Smart City Communications for BellSouth's receipt of Smart City Communications's SLI, or for the subsequent release to third parties of such SLI. In addition, to the extent BellSouth incurs costs to modify its systems to enable the release of Smart City Communications's SLI, or costs on an ongoing basis to administer the release of Smart City Communications's SLI, Smart City Communications shall pay to BellSouth its proportionate share of the reasonable costs associated therewith. At any time that costs may be incurred to administer the release of Smart City Communications's SLI, Smart City Communications will be notified. If Smart City Communications does not wish to pay its proportionate share of these reasonable costs, Smart City Communications may instruct BellSouth that it does not wish to release its SLI to independent publishers, and Smart City Communications shall amend this Agreement accordingly. Smart City Communications will be liable for all costs incurred until the effective date of the amendment.
- 7.3.3 Neither BellSouth nor any agent shall be liable for the content or accuracy of any SLI provided by Smart City Communications under this Agreement. Smart City Communications shall indemnify, except to the extent caused by BellSouth's gross negligence or willful misconduct, hold harmless and defend BellSouth and its agents from and against any damages, losses, liabilities, demands, claims, suits, judgments, costs and expenses (including but not limited to reasonable attorneys' fees and expenses) arising from BellSouth's Tariff obligations or otherwise and resulting from or arising out of any third party's claim of inaccurate Smart City Communications listings or use of the SLI provided pursuant to this Agreement. BellSouth may forward to Smart City Communications any complaints received by BellSouth relating to the accuracy or quality of Smart City Communications listings.
- 7.3.4 Listings and subsequent updates will be released consistent with BellSouth system changes and/or update scheduling requirements.

- 8. Operator Services (Operator Call Processing and Directory Assistance)**
- 8.1 Operator Call Processing (OCP) provides: (1) operator handling for call completion (for example, collect, third number billing, and manual calling-card calls); (2) operator or automated assistance for billing after the customer has dialed the called number (for example, calling card calls); and (3) special services including but not limited to Busy Line Verification and Emergency Line Interrupt (ELI), Emergency Agency Call and operator-assisted Directory Assistance (DA).
- 8.2 Upon request for BellSouth OCP, BellSouth shall:
- 8.2.1 Process 0+ and 0- dialed local calls.
- 8.2.2 Process 0+ and 0- intraLATA toll calls.
- 8.2.3 Process calls that are billed to Smart City Communications customer's calling card that can be validated by BellSouth.
- 8.2.4 Process person-to-person calls.
- 8.2.5 Process collect calls.
- 8.2.6 Provide the capability for callers to bill a third party and shall also process such calls.
- 8.2.7 Process station-to-station calls.
- 8.2.8 Process Busy Line Verify and ELI requests.
- 8.2.9 Process emergency call trace originated by PSAP.
- 8.2.10 Process operator-assisted DA calls.
- 8.2.11 Adhere to equal access requirements, providing Smart City Communications local customer the same IXC access that BellSouth provides its own operator service (OS).
- 8.2.12 Exercise at least the same level of fraud control in providing OS to Smart City Communications that BellSouth provides for its own OS.
- 8.2.13 Perform Billed Number Screening when handling Collect, Person-to-Person, and Billed-To-Third-Party calls.
- 8.2.14 Direct customer account and other similar inquiries to the customer service center designated by Smart City Communications.
- 8.3 Upon Smart City Communications's request BellSouth shall provide call records to Smart City Communications in accordance with Optional Daily Usage File (ODUF) standards.
- 8.4 The interface requirements shall conform to the interface specifications for the platform used to provide OS as long as the interface conforms to industry standards.
- 8.5 DA Service
- 8.5.1 DA Service provides local and non-local customer telephone number listings with the option to complete the call at the caller's direction separate and distinct from



local switching.

- 8.5.2 DA Service shall provide up to two (2) listing requests per call, if available and if requested by Smart City Communications's customer. BellSouth shall provide caller-optional DA call completion service at rates set forth in BellSouth's GSST to one of the provided listings.
- 8.6 DA Service Updates. BellSouth shall update customer listings changes daily. These changes include:
- 8.6.1 New customer connections;
- 8.6.2 Customer disconnections;
- 8.6.3 Customer address changes; and
- 8.6.4 Non-listed and non-published numbers for use in emergencies.

## **9. Branding for Wholesale OCP and DA**

- 9.1 BellSouth's branding feature provides a definable announcement to Smart City Communications's customers using BellSouth's DA/OCP prior to placing such customers in queue or connecting them to an available operator or automated operator system. This feature allows Smart City Communications to have its calls custom branded with Smart City Communications's name on whose behalf BellSouth is providing DA and/or OCP. Rates for the branding features are set forth in Exhibit D.
- 9.2 BellSouth offers three (3) branding options to Smart City Communications when ordering BellSouth's DA and OCP: BellSouth Branding, Unbranding and Custom Branding.
- 9.3 Smart City Communications's order for Custom Branding is considered firm ten (10) business days after BellSouth's receipt of the order. Smart City Communications may cancel its order more than ten (10) business days after BellSouth's receipt of the order. Smart City Communications shall notify BellSouth in writing and shall pay all charges per the order. For branding and unbranding via Originating Line Number Screening (OLNS), Smart City Communications must contact its Local Contract Manager to initiate the order via the OLNS Branding Order form.
- 9.4 Branding via OLNS
- 9.4.1 BellSouth Branding, Unbranding and Custom Branding are also available for DA, OCP or both via OLNS software. When utilizing this method of Unbranding or Custom Branding, Smart City Communications shall not be required to purchase dedicated trunking.
- 9.4.2 BellSouth Branding is the default branding offering.
- 9.4.3 For BellSouth to provide Unbranding or Custom Branding via OLNS software for OCP or for DA, Smart City Communications must have its OCN(s) and telephone numbers reside in BellSouth's Line Information Database (LIDB). To implement Unbranding and Custom Branding via OLNS software, Smart City

Communications must submit a manual order form which requires, among other things, Smart City Communications's OCN and a forecast, pursuant to the appropriate BellSouth form provided, for the traffic volume anticipated for each BellSouth Traffic Operator Position System (TOPS) during the peak busy hour. Smart City Communications shall provide updates to such forecast on a quarterly basis and at any time such forecasted traffic volumes are expected to change significantly. Upon Smart City Communications's purchase of Unbranding or Custom Branding using OLNS software for any particular TOPS, all Smart City Communications customers served by that TOPS will receive the Unbranded "no announcement" or the Custom Branded announcement.

**10. LIDB**

10.1 BellSouth LIDB stores current information on working telephone numbers and billing account numbers.

10.2 Where Smart City Communications is purchasing Resale services BellSouth shall utilize BellSouth's service order generated from Smart City Communications LSR's to populate LIDB with Smart City Communications's customer information. BellSouth provides access to information in its LIDB, including Smart City Communications customer information, to its LIDB customers via queries to LIDB.

10.2.1 When necessary for fraud control measures, BellSouth may perform additions, updates and deletions of Smart City Communications data to the LIDB (e.g., calling card deactivation).

10.2.2 Smart City Communications will not be charged a fee for LIDB storage services provided by BellSouth to Smart City Communications pursuant to this Attachment.

**10.3 Responsibilities of the Parties**

10.3.1 BellSouth will administer the data provided by Smart City Communications pursuant to this Agreement in the same manner as BellSouth administers its own data.

10.3.2 Smart City Communications is responsible for completeness and accuracy of the data being provided to BellSouth.

10.3.3 BellSouth shall not be responsible to Smart City Communications for any lost revenue which may result from BellSouth's administration of the LIDB pursuant to its established practices and procedures as they exist and as they may be changed by BellSouth in its sole discretion from time to time.

**11. Revenue Accounting Office (RAO) Hosting**

11.2 RAO Hosting is not required for resale in the BellSouth region.

**12. Optional Daily Usage File (ODUF)**

12.1 The ODUF Agreement with terms and conditions is included in this Attachment as Exhibit B. Rates for ODUF are as set forth in Exhibit D.

12.2 BellSouth will provide ODUF service upon written request.

**13. Enhanced Optional Daily Usage File (EODUF)**

13.1 The EODUF service Agreement with terms and conditions is included in this Attachment as Exhibit C. Rates for EODUF are as set forth in Exhibit D.

13.2 BellSouth will provide EODUF service upon written request.

**EXCLUSIONS AND LIMITATIONS ON SERVICES AVAILABLE FOR RESALE (Note 4)**

Type of Service	AL		FL		GA		KY		LA		MS		NC		SC		TN	
	Resale	Discount	Resale	Discount	Resale	Discount	Resale	Discount	Resale	Discount	Resale	Discount	Resale	Discount	Resale	Discount	Resale	Discount
1 Grandfathered Services (Note 1)	Yes	Yes	Yes	Yes	Yes	Yes	Yes	Yes	Yes	Yes	Yes	Yes	Yes	Yes	Yes	Yes	Yes	Yes
2 Promotions - > 90 Days(Note 2 &3)	Yes	Yes	Yes	Yes	Yes	Yes	Yes	Yes	Yes	Yes	Yes	Yes	Yes	Yes	Yes	Yes	Yes	Yes
3 Promotions - < 90 Days (Note 2 & 3)	No	No	No	No	No	No	No	No	No	No	No	No	No	No	No	No	No	No
4 Lifeline/Link Up Services	Yes	Yes	Yes	Yes	Yes	Yes	Yes	Yes	Yes	Yes	Yes	Yes	Yes	Yes	Yes	Yes	Yes	Yes
5 911/E911 Services	Yes	Yes	Yes	Yes	Yes	Yes	Yes	Yes	No	No	Yes	Yes	Yes	Yes	Yes	Yes	Yes	Yes
6 N11 Services (Note 1)	Yes	Yes	Yes	Yes	Yes	Yes	No	No	No	No	Yes	Yes	Yes	Yes	No	No	Yes	Yes
7 MemoryCall <sup>SM</sup> Service	Yes	No	Yes	No	Yes	No	Yes	No	Yes	No	Yes	No	Yes	No	Yes	No	Yes	No
8 Mobile Services	Yes	No	Yes	No	Yes	No	Yes	No	Yes	No	Yes	No	Yes	No	Yes	No	Yes	No
9 Federal Subscriber Line Charges	Yes	No	Yes	No	Yes	No	Yes	No	Yes	No	Yes	No	Yes	No	Yes	No	Yes	No
10 Nonrecurring Charges	Yes	Yes	Yes	Yes	Yes	Yes	Yes	Yes	Yes	Yes	Yes	Yes	Yes	Yes	Yes	Yes	Yes	No
11 EUCL Charge	Yes	No	Yes	No	Yes	No	Yes	No	Yes	No	Yes	No	Yes	No	Yes	No	Yes	No
12 Public Telephone Access Svc(PTAS)	Yes	Yes	Yes	Yes	Yes	Yes	Yes	Yes	Yes	Yes	Yes	Yes	Yes	Yes	Yes	No	Yes	Yes
13 Inside Wire Maint Service Plan	Yes	No	Yes	No	Yes	No	Yes	No	Yes	No	Yes	No	Yes	No	Yes	No	Yes	No

**Applicable Notes:**

1. **Grandfathered services** can be resold only to existing subscribers of the grandfathered service.
2. Where available for resale, **promotions** will be made available only to customers who would have qualified for the promotion had it been provided by BellSouth directly. Promotions shall be available only for the term set forth in the applicable tariff.
3. Promotions shall be available only for the term set forth in the applicable tariff.
4. Some of BellSouth's local exchange and toll Telecommunications Services are not available in certain central offices and areas.

### **Optional Daily Usage File**

1. Upon written request from Smart City Communications, BellSouth will provide the ODUF service to Smart City Communications pursuant to the terms and conditions set forth in this section.
2. Smart City Communications shall furnish all relevant information required by BellSouth for the provision of the ODUF.
3. The ODUF feed provides Smart City Communications messages that were carried over the BellSouth network and processed by BellSouth for Smart City Communications.
4. Charges for ODUF will appear on Smart City Communications's monthly bills for the previous month's usage in arrears. The charges are as set forth in Exhibit D.
5. The ODUF feed will contain both rated and unrated messages. All messages will be in the standard Alliance for Telecommunications Industry Solutions (ATIS) Exchange Message Interface (EMI) record format.
6. ODUF Specifications
  - 6.1 ODUF Message to be Transmitted
    - 6.1.1 The following messages recorded by BellSouth will be transmitted to Smart City Communications:
      - 6.1.1.1 Message recording for per use/per activation type services (examples: Three Way Calling, Verify, Interrupt, Call Return, etc.);
      - 6.1.1.2 Measured local calls;
      - 6.1.1.3 Directory Assistance messages;
      - 6.1.1.4 IntraLATA Toll;
      - 6.1.1.5 WATS and 800 Service;
      - 6.1.1.6 N11;
      - 6.1.1.7 Information Service Provider Messages;
      - 6.1.1.8 OS Messages;
      - 6.1.1.9 OS Message Attempted Calls;
      - 6.1.1.10 Credit/Cancel Records; and
      - 6.1.1.11 Usage for Voice Mail Message Service.
    - 6.1.2 Rated Incollected (messages BellSouth receives from other revenue accounting offices) appear on ODUF. Rated Incollected will be intermingled with BellSouth recorded rated and unrated usage. Rated Incollected will not be packed separately.
    - 6.1.3 BellSouth will perform duplicate record checks on records processed to ODUF. Any duplicate messages detected will be deleted and not sent to Smart City

Communications.

- 6.1.4 In the event that Smart City Communications detects a duplicate on ODUF they receive from BellSouth, Smart City Communications will drop the duplicate message and will not return the duplicate to BellSouth.
- 6.2 ODUF Physical File Characteristics
- 6.2.1 ODUF will be distributed to Smart City Communications via Secure File Transfer Protocol (FTP). The ODUF feed will be a variable block format. The data on the ODUF feed will be in a non-compacted EMI format (one hundred seventy-five (175) byte format plus modules). It will be created on a daily basis Monday through Friday except holidays. Details such as dataset name and delivery schedule will be addressed during negotiations of the distribution medium. There will be a maximum of one (1) dataset per workday per OCN. If BellSouth determines the Secure FTP Mailbox is nearing capacity levels, BellSouth may move the customer to CONNECT:Direct file delivery.
- 6.2.2 If the customer is moved, CONNECT:Direct data circuits (private line or dial-up) will be required between BellSouth and Smart City Communications for the purpose of data transmission. Where a dedicated line is required, Smart City Communications will be responsible for ordering the circuit, overseeing its installation and coordinating the installation with BellSouth. Smart City Communications will also be responsible for any charges associated with this line. Equipment required on the BellSouth end to attach the line to the mainframe computer and to transmit messages successfully on an ongoing basis will be negotiated on an individual case basis. Any costs incurred for such equipment will be Smart City Communications's responsibility. Where a dial-up facility is required, dial circuits will be installed in the BellSouth data center by BellSouth and the associated charges assessed to Smart City Communications. Additionally, all message toll charges associated with the use of the dial circuit by Smart City Communications will be the responsibility of Smart City Communications. Associated equipment on the BellSouth end, including a modem, will be negotiated on an individual case basis between the Parties. All equipment, including modems and software, that is required on Smart City Communications's end for the purpose of data transmission will be the responsibility of Smart City Communications.
- 6.2.3 If Smart City Communications utilizes FTP for data file transmission, purchase of the FTP software will be the responsibility of Smart City Communications.
- 6.3 ODUF Packing Specifications
- 6.3.1 The data will be packed using ATIS EMI records. A pack will contain a minimum of one (1) message record or a maximum of ninety-nine thousand nine hundred and ninety-nine (99,999) message records plus a pack header record and a pack trailer record. One transmission can contain a maximum of ninety-nine (99) packs and a minimum of one (1) pack.
- 6.3.2 The OCN, From RAO, and Invoice Number will control the invoice sequencing. The From RAO will be used to identify to Smart City Communications which

BellSouth RAO is sending the message. BellSouth and Smart City Communications will use the invoice sequencing to control data exchange. BellSouth will be notified of sequence failures identified by Smart City Communications and resend the data as appropriate.

6.4 ODUF Pack Rejection

6.4.1 Smart City Communications will notify BellSouth within one (1) business day of rejected packs (via the mutually agreed medium). Packs could be rejected because of pack sequencing discrepancies or a critical edit failure on the Pack Header or Pack Trailer records (e.g., out-of-balance condition on grand totals, invalid data populated). Standard ATIS EMI error codes will be used. Smart City Communications will not be required to return the actual rejected data to BellSouth. Rejected packs will be corrected and retransmitted to Smart City Communications by BellSouth.

6.5 ODUF Control Data

6.5.1 Smart City Communications will send one confirmation record per pack that is received from BellSouth. This confirmation record will indicate Smart City Communications's receipt of the pack and the acceptance or rejection of the pack. Pack Status Code(s) will be populated using standard ATIS EMI error codes for packs that were rejected by Smart City Communications for reasons stated in the above section.

6.6 ODUF Testing

6.6.1 Upon request from Smart City Communications, BellSouth shall send ODUF test files to Smart City Communications. The Parties agree to review and discuss the ODUF file content and/or format. For testing of usage results, BellSouth shall request that Smart City Communications set up a production (live) file. The live test may consist of Smart City Communications's employees making test calls for the types of services Smart City Communications requests on ODUF. These test calls are logged by Smart City Communications, and the logs are provided to BellSouth. These logs will be used to verify the files. Testing will be completed within thirty (30) days from the date on which the initial test file was sent.

**Enhanced Optional Daily Usage File**

1. Upon written request from Smart City Communications, BellSouth will provide the EODUF service to Smart City Communications pursuant to the terms and conditions set forth in this section. EODUF will only be sent to existing ODUF subscribers who request the EODUF option.
2. Smart City Communications shall furnish all relevant information required by BellSouth for the provision of the EODUF.
3. The EODUF will provide usage data for local calls originating from resold Flat Rate Business and Residential Lines.
4. Charges for EODUF will appear on Smart City Communications's monthly bills for the previous month's usage in arrears. The charges are as set forth in Exhibit D.
5. All messages will be in the standard ATIS EMI record format.
6. Messages that error in the billing system of Smart City Communications will be the responsibility of Smart City Communications. If, however, Smart City Communications should encounter significant volumes of errored messages that prevent processing by Smart City Communications within its systems, BellSouth will work with Smart City Communications to determine the source of the errors and the appropriate resolution.
7. EODUF Specifications
  - 7.1 EODUF Usage To Be Transmitted
    - 7.1.1 The following messages recorded by BellSouth will be transmitted to Smart City Communications:
      - 7.1.1.1 Customer usage data for flat rated local calls originating from Smart City Communications's customer lines (1FB or 1FR). The EODUF record for flat rate messages will include:
        - 7.1.1.1.1 Date of Call
        - 7.1.1.1.2 From Number
        - 7.1.1.1.3 To Number
        - 7.1.1.1.4 Connect Time
        - 7.1.1.1.5 Conversation Time
        - 7.1.1.1.6 Method of Recording
        - 7.1.1.1.7 From RAO
        - 7.1.1.1.8 Rate Class
        - 7.1.1.1.9 Message Type



- 7.1.1.1.10 Billing Indicators
- 7.1.1.1.11 Bill to Number
- 7.1.2 BellSouth will perform duplicate record checks on EODUF records processed to ODUF. Any duplicate messages detected will be deleted and not sent to Smart City Communications.
- 7.1.3 In the event that Smart City Communications detects a duplicate on EODUF they receive from BellSouth, Smart City Communications will drop the duplicate message and will not return the duplicate to BellSouth.
- 7.2 EODUF Physical File Characteristics
- 7.2.1 EODUF feed will be distributed to Smart City Communications via FTP. The EODUF messages will be intermingled among Smart City Communications's ODUF messages. The EODUF will be a variable block format. The data on the EODUF will be in a non-compacted EMI format (one hundred seventy-five (175) byte format plus modules). It will be created on a daily basis Monday through Friday except holiday. If BellSouth determines the Secure FTP mailbox is nearing capacity levels, BellSouth may move the customer to CONNECT:Direct file delivery.
- 7.2.2 Data circuits (private line or dial-up) may be required between BellSouth and Smart City Communications for the purpose of data transmission. Where a dedicated line is required, Smart City Communications will be responsible for ordering the circuit, overseeing its installation and coordinating the installation with BellSouth. Smart City Communications will also be responsible for any charges associated with this line. Equipment required on the BellSouth end to attach the line to the mainframe computer and to transmit successfully ongoing will be negotiated on an individual case basis. Where a dial-up facility is required, dial circuits will be installed in the BellSouth data center by BellSouth and the associated charges assessed to Smart City Communications. Additionally, all message toll charges associated with the use of the dial circuit by Smart City Communications will be the responsibility of Smart City Communications. Associated equipment on the BellSouth end, including a modem, will be negotiated on an individual case basis between the Parties. All equipment, including modems and software, that is required on Smart City Communications's end for the purpose of data transmission will be the responsibility of Smart City Communications.
- 7.2.3 If Smart City Communications utilizes FTP for data file transmission, purchase of the FTP software will be the responsibility of Smart City Communications.
- 7.3 EODUF Packing Specifications
- 7.3.1 The data will be packed using ATIS EMI records. A pack will contain a minimum of one (1) message record or a maximum of ninety-nine thousand nine hundred and ninety-nine (99,999) message records plus a pack header record and a pack trailer record. One transmission can contain a maximum of ninety-nine (99) packs and a minimum of one (1) pack.

- 7.3.2 The OCN, From RAO, and Invoice Number will control the invoice sequencing. The From RAO will be used to identify to Smart City Communications which BellSouth RAO is sending the message. BellSouth and Smart City Communications will use the invoice sequencing to control data exchange. BellSouth will be notified of sequence failures identified by Smart City Communications and resend the data as appropriate.

RESALE DISCOUNTS & RATES - Florida										Att: 1 Exh: D												
CATEGORY	RATE ELEMENTS	Interim	Zone	BCS	USOC	RATES(\$)				Svc Order Submitted Elec per LSR	Svc Order Submitted Manually per LSR	Incremental Charge - Manual Svc Order vs. Electronic-1st	Incremental Charge - Manual Svc Order vs. Electronic-Add'l	Incremental Charge - Manual Svc Order vs. Electronic-Disc 1st	Incremental Charge - Manual Svc Order vs. Electronic-Disc Add'l							
						Rec	Nonrecurring		Nonrecurring Disconnect							OSS Rates(\$)						
							First	Add'l	First							Add'l	SOMEc	SOMAN	SOMAN	SOMAN	SOMAN	SOMAN
<b>RESALE APPLICABLE DISCOUNTS</b>																						
	Residence %					21.83																
	Business %					16.81																
	CSAs %					16.81																
<b>OPERATIONS SUPPORT SYSTEMS (OSS) - "REGIONAL RATES"</b>																						
NOTE: (1) CLEC should contact its contract negotiator if it prefers the "state specific" OSS charges as ordered by the State Commissions. The OSS charges currently contained in this rate exhibit are the BellSouth "regional" service ordering charges. CLEC may elect either the state specific Commission ordered rates for the service ordering charges, or CLEC may elect the regional service ordering charge, however, CLEC can not obtain a mixture of the two regardless if CLEC has an interconnection contract established in each of the 9 states.																						
	OSS - Electronic Service Order Charge, Per Local Service Request (LSR) - Resale Only				SOMEc	3.50	0.00	3.50	0.00													
	OSS - Manual Service Order Charge, Per Local Service Request (LSR) - Resale Only				SOMAN	19.99	0.00	19.99	0.00													
<b>ODUF/EODUF SERVICES</b>																						
<b>OPTIONAL DAILY USAGE FILE (ODUF)</b>																						
	ODUF: Recording, per message					0.0000071																
	ODUF: Message Processing, per message					0.002146																
	ODUF: Message Processing, per Magnetic Tape provisioned					35.91																
	ODUF: Data Transmission (CONNECT:DIRECT), per message					0.00010375																
<b>ENHANCED OPTIONAL DAILY USAGE FILE (EODUF)</b>																						
	EODUF: Message Processing, per message					0.080698																
<b>SELECTIVE CALL ROUTING USING LINE CLASS CODES (SCR-LCC)</b>																						
	Selective Routing Per Unique Line Class Code Per Request Per Switch					93.55	93.55	12.71	12.71													
<b>DIRECTORY ASSISTANCE CUSTOM BRANDING ANNOUNCEMENT via OLNS SOFTWARE</b>																						
	Recording of DA Custom Branded Announcement					3,000.00	3,000.00															
	Loading of DA Custom Branded Announcement per Switch per OCN					1,170.00	1,170.00															
<b>DIRECTORY ASSISTANCE UNBRANDING via OLNS SOFTWARE</b>																						
	Loading of DA per OCN (1 OCN per Order)					420.00	420.00															
	Loading of DA per Switch per OCN					16.00	16.00															
<b>OPERATOR ASSISTANCE CUSTOM BRANDING ANNOUNCEMENT via OLNS SOFTWARE</b>																						
	Recording of Custom Branded OA Announcement					7,000.00	7,000.00															
	Loading of Custom Branded OA Announcement per shelf/NAV per OCN					500.00	500.00															
	Loading of OA Custom Branded Announcement per Switch per OCN					1,170.00	1,170.00															
<b>OPERATOR ASSISTANCE UNBRANDING via OLNS SOFTWARE</b>																						
	Loading of OA per OCN (Regional)					1,200.00	1,200.00															

## **Attachment 2**

### **Network Elements and Other Services**

**TABLE OF CONTENTS**

**1 Introduction..... 3**

**2 Loops..... 9**

**3 Line Splitting..... 33**

**4 Unbundled Network Element Combinations ..... 34**

**5 Dedicated Transport and Dark Fiber Transport ..... 37**

**6 Automatic Location Identification/Data Management System (ALI/DMS) ..... 44**

**7 White Pages Listings ..... 48**

**Rates ..... Exhibit A**

**Rates ..... Exhibit B**

**Wire Centers..... Exhibit C**

## ACCESS TO NETWORK ELEMENTS AND OTHER SERVICES

### 1 Introduction

- 1.1 This Attachment sets forth rates, terms and conditions for unbundled network elements (Network Elements) and combinations of Network Elements (Combinations) that BellSouth offers to Smart City Communications for Smart City Communications's provision of Telecommunications Services in accordance with its obligations under Section 251(c)(3) of the Act. Additionally, this Attachment sets forth the rates, terms and conditions for other facilities and services BellSouth makes available to Smart City Communications (Other Services). Additionally, the provision of a particular Network Element or Other Service may require Smart City Communications to purchase other Network Elements or services. In the event of a conflict between this Attachment and any other section or provision of this Agreement, the provisions of this Attachment shall control.
- 1.2 The rates for Network Elements, Combinations and Other Services are set forth in Exhibits A and B. If no rate is identified in this Agreement, the rate will be as set forth in the applicable BellSouth tariff or as negotiated by the Parties upon request by either Party. If Smart City Communications purchases service(s) from a tariff, all terms and conditions and rates as set forth in such tariff shall apply. A one-month minimum billing period shall apply to all Network Elements, Combinations and Other Services.
- 1.3 In some cases, Commissions have ordered BellSouth to separate its disconnect costs and its installation costs into two separate nonrecurring charges. Accordingly, unless otherwise noted in this Agreement, the Commission ordered disconnect charges will be applied at the time the disconnect activity is performed by BellSouth, regardless of whether or not a disconnect order is issued by Smart City Communications. Disconnect charges are set forth in the rate exhibit of this Attachment. Smart City Communications may purchase and use Network Elements and Other Services from BellSouth in accordance with 47 C.F.R § 51.309.
- 1.4 The Parties shall comply with the requirements as set forth in the technical references within this Attachment 2.
- 1.5 Smart City Communications shall not obtain a Network Element for the exclusive provision of mobile wireless services or interexchange services.
- 1.6 Conversion of Wholesale Services to Network Elements or Network Elements to Wholesale Services. Upon request, BellSouth shall convert a wholesale service, or group of wholesale services, to the equivalent Network Element or Combination that is available to Smart City Communications pursuant to Section 251 of the Act

and under this Agreement or convert a Network Element or Combination that is available to Smart City Communications pursuant to Section 251 of the Act and under this Agreement to an equivalent wholesale service or group of wholesale services offered by BellSouth (collectively "Conversion"). BellSouth shall charge the applicable nonrecurring switch-as-is rates for Conversions to specific Network Elements or Combinations found in Exhibit A. BellSouth shall also charge the same nonrecurring switch-as-is rates when converting from Network Elements or Combinations. Any rate change resulting from the Conversion will be effective as of the next billing cycle following BellSouth's receipt of a complete and accurate Conversion request from Smart City Communications. A Conversion shall be considered termination for purposes of any volume and/or term commitments and/or grandfathered status between Smart City Communications and BellSouth. Any change from a wholesale service/group of wholesale services to a Network Element/Combination, or from a Network Element/Combination to a wholesale service/group of wholesale services, that requires a physical rearrangement will not be considered to be a Conversion for purposes of this Agreement. BellSouth will not require physical rearrangements if the Conversion can be completed through record changes only. Orders for Conversions will be handled in accordance with the guidelines set forth in the Ordering Guidelines and Processes and CLEC Information Packages as referenced in Sections 1.13.1 and 1.13.2 below.

- 1.7 Except to the extent expressly provided otherwise in this Attachment, in all states, Smart City Communications may not maintain unbundled network elements or combinations of unbundled network elements, that are no longer offered pursuant to this Agreement (collectively "Arrangements"). In the event BellSouth determines that Smart City Communications has in place any Arrangements after the Effective Date of this Agreement, BellSouth will identify such Arrangements and provide Smart City Communications with thirty (30) days written notice to disconnect or convert such Arrangements. For orders submitted by Smart City Communications within such thirty (30) day period, BellSouth will charge the applicable switch-as-is charge set forth in Exhibit A. If Smart City Communications fails to submit orders to disconnect or convert such Arrangements within such thirty (30) day period, BellSouth will transition such circuits to the equivalent tariffed BellSouth service(s), and shall charge Smart City Communications all applicable disconnect charges as set forth in this Agreement and the full nonrecurring charges for installation of the equivalent tariffed BellSouth service as set forth in BellSouth's tariffs. For all transitions pursuant to this Section 1.7 that require a physical rearrangement, BellSouth shall charge any applicable nonrecurring installation charges. To the extent no tariff equivalent service exists, BellSouth shall disconnect such facility or Arrangement. The applicable recurring tariff charge shall apply to each circuit as of the Effective Date of this Agreement.

- 1.7.1 In addition to the foregoing, for the state of Florida, the applicable recurring tariff charges shall apply to each circuit beginning the day following the thirty (30) day notice period.
- 1.8 BellSouth's Master List of Unimpaired Wire Centers as Approved by State Commissions in its Region (Master List of Unimpaired Wire Centers), located on the BellSouth Interconnection Web site designates those wire centers that, in accordance with state Commission orders, met the FCC's established criteria for non-impairment, as of March 11, 2005, where certain high capacity (DS1 and above) Loops and high capacity Dedicated Transport are no longer available as Network Elements. The Master List of Unimpaired Wire Centers shall be subject to modification and/or the addition of wire centers without amendment to this Agreement upon subsequent orders from state Commissions in the respective generic dockets establishing the wire centers that as of March 11, 2005, were unimpaired. Notification of such modification, addition or deletion of wire centers shall be made via BellSouth's Carrier Notification process on BellSouth's Interconnection Web site. Upon the Effective Date of this Agreement, Smart City Communications may not place any new orders for high capacity Dedicated Transport or high capacity Loops, as applicable, in those wire centers listed on the Master List of Unimpaired Wire Centers. To the extent Smart City Communications placed orders after March 10, 2005 for high capacity Loops or high capacity Dedicated Transport in wire centers designated on the Master List of Unimpaired Wire Centers, as amended as specified above, within thirty (30) days after the Effective Date of this Agreement, or in the case of additions to the Master List of Unimpaired Wire Centers, within thirty (30) days after the notice of such addition, Smart City Communications shall submit an LSR(s) or spreadsheet(s), as applicable, identifying those non-compliant circuits to be disconnected or converted to the equivalent BellSouth tariffed service. BellSouth shall bill Smart City Communications the difference between the UNE recurring rates for such circuits pursuant to this Agreement and the applicable recurring charges for the equivalent BellSouth tariffed service from the date UNE circuit was installed in the unimpaired wire center to the date the circuit is disconnected or transitioned to the equivalent BellSouth tariffed service. If Smart City Communications fails to submit an LSR or spreadsheet identifying such de-listed circuits within thirty (30) days as set forth above, BellSouth will identify such circuits and convert them to the equivalent BellSouth tariffed service, and charge Smart City Communications applicable disconnect charges for the UNE circuit and the difference between the UNE recurring rate billed for such circuit and the full non-recurring and recurring charges for the tariffed service from the date the UNE circuit was installed in the unimpaired wire center to the date the circuit is transitioned to the equivalent BellSouth tariffed service. To the extent there is no equivalent BellSouth tariffed service for the de-listed UNE circuit, BellSouth will disconnect the circuit and bill Smart City Communications full disconnect charges.



- 1.8.1 Prior to submitting an order pursuant to this Agreement for high capacity Dedicated Transport or high capacity Loops, Smart City Communications shall undertake a reasonably diligent inquiry to determine whether Smart City Communications is entitled to unbundled access to such Network Elements in accordance with the terms of this Agreement. By submitting any such order, Smart City Communications self-certifies that to the best of Smart City Communications's knowledge, the high capacity Dedicated Transport or high capacity Loop requested is available as a Network Element pursuant to this Agreement. Upon receiving such order, except in wire centers set forth on the Master List of Unimpaired Wire Centers, or BellSouth's List of Unimpaired Wire Centers, BellSouth shall process the request in reliance upon Smart City Communications's self-certification. To the extent BellSouth believes that such request does not comply with the terms of this Agreement, BellSouth shall seek dispute resolution in accordance with the General Terms and Conditions of this Agreement. In the event such dispute is resolved in BellSouth's favor, BellSouth shall bill Smart City Communications the difference between the rates for such circuits pursuant to this Agreement and the applicable nonrecurring and recurring charges for the equivalent tariffed service from the date of installation to the date the circuit is transitioned to the equivalent tariffed service. Within thirty (30) days following a decision finding in BellSouth's favor, Smart City Communications shall submit an LSR(s) or spreadsheet(s) identifying those non-compliant circuits to be transitioned to tariffed services or disconnected.
- 1.8.2 In the event that (1) BellSouth designated a wire center as unimpaired as set forth on the Master List of Unimpaired Wire Centers on the BellSouth Interconnection Web site, or BellSouth's List of Unimpaired Wire Centers, (2) as a result of such designation, Smart City Communications converted high capacity Dedicated Transport or high capacity Loops to other services or ordered new services as services other than high capacity Dedicated Transport or high capacity Loop Network Elements subsequent to March 10, 2005, (3) Smart City Communications otherwise would have been entitled to high capacity Dedicated Transport or high capacity Loops in such wire center at the time such alternative services were provisioned, and (4) BellSouth acknowledges, or a state or federal regulatory body with authority determines, that, at the time BellSouth designated such wire center as unimpaired, such wire center did not meet the FCC's unimpairment criteria, then upon request of Smart City Communications consistent with the applicable ordering processes as reflected in the Guides located on BellSouth's Interconnection Web site no later than sixty (60) days after BellSouth acknowledges or the state or federal regulatory body issues an order making such a finding, BellSouth shall transition to high capacity Dedicated Transport or high capacity Loops, as appropriate, any alternative services in such wire center that were established after such wire center was designated as unimpaired. In such instances, BellSouth shall refund to Smart City Communications the difference between the rate paid by Smart City Communications for such services and the

applicable rates set forth herein for high capacity Dedicated Transport or high capacity Loops, including but not limited to any charges associated with the Conversion (as defined in Section 1.6 above ) from high capacity Dedicated Transport or high capacity Loops to other wholesale services, if applicable, for the period from the later of March 11, 2005, or the date the circuit became a wholesale service to the date the circuit is transitioned to high capacity Dedicated Transport or high capacity Loop as described in this Section.

- 1.8.3 The current wire center list as of January 26, 2007 is set forth in Exhibit C.
- 1.9 Smart City Communications may utilize Network Elements and Other Services to provide services in accordance with this Agreement, as long as such services are consistent with industry standards and applicable BellSouth Technical References.
- 1.10 BellSouth will perform Routine Network Modifications (RNM) in accordance with FCC 47 C.F.R. § 51.319 (a)(7) and (e)(4) for Loops and Dedicated Transport provided under this Attachment. If BellSouth has anticipated such RNM and performs them during normal operations and has recovered the costs for performing such modifications through the rates set forth in Exhibit A, then BellSouth shall perform such RNM at no additional charge. RNM shall be performed within the intervals established for the Network Element and subject to the service quality measurements and associated remedies set forth in Attachment 9 to the extent such RNM were anticipated in the setting of such intervals. If BellSouth has not anticipated a requested network modification as being a RNM and has not recovered the costs of such RNM in the rates set forth in Exhibit A, then such request will be handled as a project on an individual case basis. BellSouth will provide a price quote for the request and, upon receipt of payment from Smart City Communications, BellSouth shall perform the RNM.
- 1.11 Commingling of Services
- 1.11.1 Commingling means the connecting, attaching, or otherwise linking of a Network Element, or a Combination, to one or more Telecommunications Services or facilities that Smart City Communications has obtained at wholesale from BellSouth, or the combining of a Network Element or Combination with one or more such wholesale Telecommunications Services or facilities. Smart City Communications must comply with all rates, terms or conditions applicable to such wholesale Telecommunications Services or facilities.
- 1.11.2 Subject to the limitations set forth elsewhere in this Attachment, BellSouth shall not deny access to a Network Element or a Combination on the grounds that one or more of the elements: (1) is connected to, attached to, linked to, or combined with such a facility or service obtained from BellSouth; or (2) shares part of BellSouth's network with access services or inputs for mobile wireless services and/or interexchange services.

- 1.11.3 Notwithstanding any other provision of this Agreement, BellSouth shall not be obligated to commingle or combine, pursuant to this Agreement, Network Elements or Combinations with any service, network element or other offering that it is obligated to make available pursuant only to Section 271 of the Act.
- 1.11.4 Unless otherwise agreed to by the Parties, the Network Element portion of a commingled circuit will be billed at the rates set forth in this Agreement and the remainder of the circuit or service will be billed in accordance with BellSouth's tariffed rates or rates set forth in a separate agreement between the Parties, as applicable.
- 1.11.5 When multiplexing equipment is attached to a commingled circuit, the multiplexing equipment will be billed from the same agreement or tariff as the higher bandwidth circuit. Central Office Channel Interfaces (COCI) will be billed from the same agreement or tariff as the lower bandwidth circuit.
- 1.11.6 The Commingling process and requirements will be handled in accordance with the guidelines set forth in the Ordering Guidelines and Processes and CLEC Information Packages as referenced in Sections 1.13.1 and 1.13.2 below.
- 1.12 Terms and conditions for order cancellation charges and Service Date Advancement Charges will apply in accordance with Attachment 6 and are incorporated herein by this reference. The charges shall be as set forth in Exhibit A.
- 1.13 Ordering Guidelines and Processes
- 1.13.1 For information regarding Ordering Guidelines and Processes for various Network Elements, Combinations and Other Services, Smart City Communications should refer to the "Guides" section of the BellSouth Interconnection Web site.
- 1.13.2 Additional information may also be found in the individual CLEC Information Packages, located at the "CLEC UNE Products" on BellSouth's Interconnection Web site.
- 1.13.3 The provisioning of Network Elements, Combinations and Other Services to Smart City Communications's Collocation Space will require cross-connections within the central office to connect the Network Element, Combinations or Other Services to the demarcation point associated with Smart City Communications's Collocation Space. These cross-connects are separate components that are not considered a part of the Network Element, Combinations or Other Services and, thus, have a separate charge pursuant to Attachment 4.

1.13.4 Testing/Trouble Reporting

- 1.13.4.1 Smart City Communications will be responsible for testing and isolating troubles on Network Elements. Smart City Communications must test and isolate trouble to the BellSouth network before reporting the trouble to the Network Elements Customer Wholesale Interconnection Network Services (CWINS) Center. Upon request from BellSouth at the time of the trouble report, Smart City Communications will be required to provide the results of the Smart City Communications test which indicate a problem on the BellSouth network.
- 1.13.4.2 Once Smart City Communications has isolated a trouble to the BellSouth network, and has issued a trouble report to BellSouth, BellSouth will take the actions necessary to repair the Network Element when trouble is found. BellSouth will repair its network facilities to its wholesale customers in the same time frames that BellSouth repairs similar services to its retail customers.
- 1.13.4.3 If Smart City Communications reports a trouble on a BellSouth Network Element and no trouble is found in BellSouth's network, BellSouth will charge Smart City Communications a Maintenance of Service Charge for any dispatching and testing (both inside and outside the CO) required by BellSouth in order to confirm the Network Element's working status. BellSouth will assess the applicable Maintenance of Service rates from BellSouth's FCC No.1 Tariff, Section 13.3.1.
- 1.13.4.4 In the event BellSouth must dispatch to the customer's location more than once due to incorrect or incomplete information provided by Smart City Communications (e.g., incomplete address, incorrect contact name/number, etc.), BellSouth will bill Smart City Communications for each additional dispatch required to repair the Network Element due to the incorrect/incomplete information provided. BellSouth will assess the applicable Maintenance of Service rates from BellSouth's FCC No.1 Tariff, Section 13.3.1.

**2 Loops**

- 2.1 General. The local loop Network Element is defined as a transmission facility that BellSouth provides pursuant to this Attachment between a distribution frame (or its equivalent) in BellSouth's central office and the loop demarcation point at a customer premises (Loop). Facilities that do not terminate at a demarcation point at a customer premises, including, by way of example, but not limited to, facilities that terminate to another carrier's switch or premises, a cell site, Mobile Switching Center or base station, do not constitute local Loops. The Loop Network Element includes all features, functions, and capabilities of the transmission facilities, including the network interface device, and attached electronics (except those used for the provision of advanced services, such as Digital Subscriber Line Access Multiplexers (DSLAMs)), optronics and intermediate devices (including repeaters and load coils) used to establish the transmission path to the customer's premises,

including inside wire owned or controlled by BellSouth. Smart City Communications shall purchase the entire bandwidth of the Loop and, except as required herein or as otherwise agreed to by the Parties, BellSouth shall not subdivide the frequency of the Loop.

- 2.1.1 The Loop does not include any packet switched features, functions or capabilities.
- 2.1.2 Fiber to the Home (FTTH) loops are local loops consisting entirely of fiber optic cable, whether dark or lit, serving a customer's premises or, in the case of predominantly residential multiple dwelling units (MDUs), a fiber optic cable, whether dark or lit, that extends to the MDU minimum point of entry (MPOE). Fiber to the Curb (FTTC) loops are local loops consisting of fiber optic cable connecting to a copper distribution plant that is not more than five hundred (500) feet from the customer's premises or, in the case of predominantly residential MDUs, not more than five hundred (500) feet from the MDU's MPOE. The fiber optic cable in a FTTC loop must connect to a copper distribution plant at a serving area interface from which every other copper distribution subloop also is not more than five hundred (500) feet from the respective customer's premises.
  - 2.1.2.1 In new build (Greenfield) areas, where BellSouth has only deployed FTTH/FTTC facilities, BellSouth is under no obligation to provide Loops. FTTH facilities include fiber loops deployed to the MPOE of a MDU that is predominantly residential regardless of the ownership of the inside wiring from the MPOE to each customer in the MDU.
  - 2.1.2.2 In FTTH/FTTC overbuild situations where BellSouth also has copper Loops, BellSouth will make those copper Loops available to Smart City Communications on an unbundled basis, until such time as BellSouth chooses to retire those copper Loops using the FCC's network disclosure requirements. In these cases, BellSouth will offer a sixty-four (64) kilobits per second (kbps) voice grade channel over its FTTH/FTTC facilities.
  - 2.1.2.3 Furthermore, in FTTH/FTTC overbuild areas where BellSouth has not yet retired copper facilities, BellSouth is not obligated to ensure that such copper Loops in that area are capable of transmitting signals prior to receiving a request for access to such Loops by Smart City Communications. If a request is received by BellSouth for a copper Loop, and the copper facilities have not yet been retired, BellSouth will restore the copper Loop to serviceable condition if technically feasible. In these instances of Loop orders in an FTTH/FTTC overbuild area, BellSouth's standard Loop provisioning interval will not apply, and the order will be handled on a project basis by which the Parties will negotiate the applicable provisioning interval.
- 2.1.3 A hybrid Loop is a local Loop, composed of both fiber optic cable, usually in the feeder plant, and copper twisted wire or cable, usually in the distribution plant.

BellSouth shall provide Smart City Communications access to hybrid Loops pursuant to the requirements of 47 C.F.R. § 51.319(a)(2). BellSouth is not required to provide access to the packet switched features, functions and capabilities of its hybrid Loops.

- 2.1.3.1 BellSouth shall not engineer the transmission capabilities of its network in a manner, or engage in any policy, practice, or procedure, that disrupts or degrades access to a local Loop or Subloop, including the time division multiplexing-based features, functions and capabilities of a hybrid Loop, for which a requesting telecommunications carrier may obtain or has obtained access pursuant to this Attachment.
- 2.1.4 DS1 and DS3 Loop Requirements
  - 2.1.4.1 For purposes of this Section 2, a Business Line is defined in 47 C.F.R. § 51.5.
  - 2.1.4.2 For purposes of this Section 2, a “Fiber-Based Collocator” is defined in 47 C.F.R. § 51.5.
  - 2.1.4.3 Notwithstanding anything to the contrary in this Agreement, BellSouth shall make available DS1 and DS3 Loops as described in this Agreement, except in any wire center meeting the criteria described below:
    - 2.1.4.3.1 DS1 Loops at any location within the service area of a wire center containing sixty thousand (60,000) or more Business Lines and four (4) or more fiber-based collocators.
    - 2.1.4.3.2 DS3 Loops at any location within the service area of a wire center containing thirty-eight thousand (38,000) or more Business Lines and four (4) or more fiber-based collocators.
  - 2.1.4.4 The Master List of Unimpaired Wire Centers and BellSouth’s List of Unimpaired Wire Centers as described in Section 1.8 sets forth the list of wire centers meeting the criteria set forth in Sections 2.1.4.3.1 and 2.1.4.3.2 above as of March 11, 2005.
  - 2.1.4.5 Once any wire center exceeds both of the thresholds set forth in Section 2.1.4.3.1 above, no future DS1 Loop unbundling will be required in that wire center.
  - 2.1.4.6 Once any wire center exceeds both of the thresholds set forth in Section 2.1.4.3.2 above, no future DS3 Loop unbundling will be required in that wire center.

2.1.4.7 Modifications and Updates to the Wire Center Lists and Subsequent Transition Periods

2.1.4.7.1 In the event BellSouth identifies additional wire centers that meet the criteria set forth in Section 2.1.4.3 above but that were not included in the Master List of Unimpaired Wire Centers and BellSouth's List of Unimpaired Wire Centers, BellSouth shall include such additional wire centers in a carrier notification letter (CNL). Each such list of additional wire centers shall be considered a "Subsequent Wire Center List". BellSouth will follow any notification procedures set forth in applicable Commission orders.

2.1.4.7.2 Smart City Communications shall have thirty (30) business days to dispute the additional wire centers listed on Bellsouth's CNL. Absent such dispute, effective thirty (30) business days after the date of a BellSouth CNL providing a Subsequent Wire Center List, BellSouth shall not be required to unbundle DS1 and/or DS3 Loops, as applicable, in such additional wire center(s), except pursuant to the self-certification process as set forth in Section 1.8 of this Attachment.

2.1.4.7.2.1 For purposes of Section 2.1.4.7 above, BellSouth shall make available DS1 and DS3 Loops that were in service for Smart City Communications in a wire center on the Subsequent Wire Center List as of the thirtieth (30<sup>th</sup>) business day after the date of BellSouth's CNL identifying the Subsequent Wire Center List (Subsequent Embedded Base) until one hundred eighty (180) days after the thirtieth (30<sup>th</sup>) business day from the date of BellSouth's CNL identifying the Subsequent Wire Center List (Subsequent Transition Period).

2.1.4.7.2.2 The rates set forth in Exhibit B shall apply to the Subsequent Embedded Base during the Subsequent Transition Period.

2.1.4.7.2.3 No later than one hundred eighty (180) days from BellSouth's CNL identifying the Subsequent Wire Center List, Smart City Communications shall submit an LSR(s) or spreadsheet(s) as applicable, identifying the Subsequent Embedded Base of circuits to be disconnected or converted to other BellSouth services.

2.1.4.7.2.3.1 In the case of disconnection, the applicable disconnect charges set forth in this Agreement shall apply.

2.1.4.7.2.3.2 If Smart City Communications fails to submit the LSR(s) or spreadsheet(s) for all of its Subsequent Embedded Base by one hundred eighty (180) days after the date of BellSouth's CNL identifying the Subsequent Wire Center List, BellSouth will identify Smart City Communications's remaining Subsequent Embedded Base, if any, and will transition such circuits to the equivalent tariffed BellSouth service(s). In the state of Florida, those circuits identified and transitioned by BellSouth shall be subject to the applicable disconnect charges as set forth in this Agreement and

the full nonrecurring charges for installation of the equivalent tariffed BellSouth service as set forth in BellSouth's tariffs.

- 2.1.4.7.2.3.3 For Subsequent Embedded Base circuits converted pursuant to Section 2.1.4.7.2.3 above or transitioned pursuant to Section 2.1.4.7.2.3.2 above, the applicable recurring tariff charges shall apply as of the earlier of the date each circuit is converted or transitioned, as applicable, or the first day after the end of the Subsequent Transition Period.
- 2.1.5 Where facilities are available, BellSouth will install Loops in compliance with BellSouth's Products and Services Interval Guide available at BellSouth's Interconnection Web site. For orders of fifteen (15) or more Loops, the installation and any applicable Order Coordination (OC) as described below will be handled on a project basis, and the intervals will be set by the BellSouth project manager for that order. When Loops require a Service Inquiry (SI) prior to issuing the order to determine if facilities are available, the interval for the SI process is separate from the installation interval.
- 2.1.6 The Loop shall be provided to Smart City Communications in accordance with BellSouth's TR73600 Unbundled Local Loop Technical Specification and applicable industry standard technical references.
- 2.1.7 BellSouth will only provision, maintain and repair the Loops to the standards that are consistent with the type of Loop ordered.
  - 2.1.7.1 When a BellSouth technician is required to be dispatched to provision the Loop, BellSouth will tag the Loop with the Circuit ID number and the name of the ordering CLEC. When a dispatch is not required to provision the Loop, BellSouth will tag the Loop on the next required visit to the customer's location. If Smart City Communications wants to ensure the Loop is tagged during the provisioning process for Loops that may not require a dispatch (e.g., UVL-SL1, UVL-SL2, and UCL-ND), Smart City Communications may order Loop Tagging. Rates for Loop Tagging are as set forth in Exhibit A.
  - 2.1.7.2 For voice grade Loop orders (or orders for Loops intended to provide voice grade services), Smart City Communications shall have dial-tone available for that Loop forty-eight (48) hours prior to the Loop order completion due date. This applies to all conversions from one provider to another provider as well as Service Rearrangements as set forth in Section 2.1.12. Where Smart City Communications dial-tone is not available on the conversion date the Loop will not be cut over and the Loop order will be returned to Smart City Communications for rescheduling.



2.1.8 OC and Order Coordination-Time Specific (OC-TS)

2.1.8.1 OC allows BellSouth and Smart City Communications to coordinate the installation of the SL2 Loops, Unbundled Digital Loops (UDL) and other Loops where OC may be purchased as an option, to Smart City Communications's facilities to limit customer service outage. OC is available when the Loop is provisioned over an existing circuit that is currently providing service to the customer. OC for physical conversions will be scheduled at BellSouth's discretion during normal working hours on the committed due date. OC shall be provided in accordance with the chart set forth below.

2.1.8.2 OC-TS allows Smart City Communications to order a specific time for OC to take place. BellSouth will make commercially reasonable efforts to accommodate Smart City Communications's specific conversion time request. However, BellSouth reserves the right to negotiate with Smart City Communications a conversion time based on load and appointment control when necessary. This OC-TS is a chargeable option for all Loops except Unbundled Copper Loops (UCL) and is billed in addition to the OC charge. Smart City Communications may specify a time between 9:00 a.m. and 4:00 p.m. (location time) Monday through Friday (excluding holidays). If Smart City Communications specifies a time outside this window, or selects a time or quantity of Loops that requires BellSouth technicians to work outside normal work hours, overtime charges will apply in addition to the OC and OC-TS charges. Overtime charges will be applied based on the amount of overtime worked and in accordance with the rates established in BellSouth's intrastate Access Services Tariff, Section E13.2, for each state. The OC-TS charges for an order due on the same day at the same location will be applied on a per LSR basis.

2.1.9

	<b>Order Coordination (OC)</b>	<b>Order Coordination – Time Specific (OC-TS)</b>	<b>Test Points</b>	<b>DLR</b>	<b>Charge for Dispatch and Testing if No Trouble Found</b>
<b>SL-1 (Non-Designed)</b>	Chargeable Option	Chargeable Option	Not available	Chargeable Option – ordered as Engineering Information Document	Charged for Dispatch inside and outside Central Office
<b>UCL-ND (Non-Designed)</b>	Chargeable Option	Not Available	Not Available	Chargeable Option – ordered as Engineering Information Document	Charged for Dispatch inside and outside Central Office
<b>Unbundled Voice Loops - SL-2 (including 2- and 4-wire UVL) (Designed)</b>	Included	Chargeable Option	Included	Included	Charged for Dispatch outside Central Office
<b>Unbundled Digital Loop (Designed)</b>	Included	Chargeable Option	Included (where appropriate)	Included	Charged for Dispatch outside Central Office
<b>Unbundled Copper Loop (Designed)</b>	Chargeable in accordance with Section 2	Not available	Included	Included	Charged for Dispatch outside Central Office
For UVL-SL1 and UCLs, Smart City Communications must order and will be billed for both OC and OC-TS if requesting OC-TS.					

2.1.10 CLEC to CLEC Conversions for Unbundled Loops

2.1.10.1 The CLEC to CLEC conversion process for Loops may be used by Smart City Communications when converting an existing Loop from another CLEC for the same customer. The Loop type being converted must be included in Smart City Communications’s Agreement before requesting a conversion.

- 2.1.10.2 To utilize the CLEC to CLEC conversion process, the Loop being converted must be the same Loop type with no requested changes to the Loop, must serve the same customer location from the same serving wire center, and must not require an outside dispatch to provision.
- 2.1.10.3 The Loops converted to Smart City Communications pursuant to the CLEC to CLEC conversion process shall be provisioned in the same manner and with the same functionality and options as described in this Agreement for the specific Loop type.
- 2.1.11 Bulk Migration
- 2.1.11.1 BellSouth will make available to Smart City Communications a Bulk Migration process pursuant to which Smart City Communications may request to migrate port/loop combinations, provisioned pursuant to a separate agreement between the parties, to Loops (UNE-L). The Bulk Migration process may be used if such loop/port combinations are (1) associated with two (2) or more Existing Account Telephone Numbers (EATNs); and (2) located in the same Central Office. The terms and conditions for use of the Bulk Migration process are described in the BellSouth CLEC Information Package. The CLEC Information Package is located on BellSouth's Interconnection Web site. The rates for the Bulk Migration process shall be the nonrecurring rates associated with the Loop type being requested on the Bulk Migration, as set forth in Exhibit A. Additionally, OSS charges will also apply. Loops connected to Integrated Digital Loop Carrier (IDLC) systems will be migrated pursuant to Section 2.6 below.
- 2.1.11.2 Should Smart City Communications request migration for two (2) or more EATNs containing fifteen (15) or more circuits, Smart City Communications must use the Bulk Migration process referenced in 2.1.11.1 above.
- 2.1.12 Unbundled Loop (DS1 and below) Service Rearrangements
- 2.1.12.1 The Unbundled Loop Service Rearrangement processes will allow changes to be made to a working Loop facility assignment within the same end-user serving wire center. Service Rearrangements will result in service outages to the customer during the time the Loop is being moved.
- 2.1.12.2 An Unbundled Loop Service Rearrangement connecting facility change (CFC) allows Smart City Communications to change its installed Loop from one working facility assignment to another facility assignment. CFC includes Connecting Facility Assignment (CFA) and Cable ID & Pair changes within same collocation arrangement or from collocation to collocation. CFA changes are allowed within the same multiplexer or from one multiplexer to another multiplexer. For a CFC, the Loop class of service, Loop type and the customer must remain the same.

- 2.1.12.3 An Unbundled Loop Service Rearrangement connecting facility move (CFM) allows Smart City Communications to move the Loop facility assignment from a collocation arrangement to a multiplexer or from a multiplexer to a collocation arrangement. CFMs require a change to the Loop basic class of service. The Loop type and the customer must remain the same.
- 2.1.12.4 For Unbundled Loop Service Rearrangements, BellSouth shall charge the applicable "Service Rearrangement change in Loop facility" rate found in Exhibit A.
- 2.1.12.5 The Unbundled Loop Service Rearrangement process and requirements will be handled in accordance with the guidelines set forth in the Ordering Guidelines and CLEC Information Packages as referenced in Sections 1.13.1 and 1.13.2 above.
- 2.1.13 EEL to Loop Retermination
- 2.1.13.1 Smart City Communications may utilize the EEL to Loop Retermination process to disconnect an EEL circuit and reterminate the Loop portion of the former EEL circuit to a collocation arrangement in the end-user's Serving Wire Center (EU SWC).
- 2.1.13.2 This process is available when the existing Loop portion of the EEL will be re-used and the resulting Loop will be subject to the rates, terms and conditions for that particular Loop as set forth in this Attachment. This process will apply only to EELs that include as a part of its combination a DS1 Loop, UVL-SL2 Loop, 4-Wire UDL Loop (64, 56 kbs) and a 2-Wire ISDN Loop.
- 2.1.13.3 BellSouth shall charge the applicable EEL to Loop Retermination rates found in Exhibit A. Smart City Communications shall also be charged applicable manual service order, collocation cross-connect and EEL (including the Transport and Loop portions of the EEL) disconnect charges as set forth in Exhibit A of this Attachment.
- 2.1.13.4 The EEL to Loop Retermination process is not available when a dispatch outside the serving wire center where the Loop terminates is required. If an outside dispatch is required, or if the Loop portion of the EEL is not one of the Loop types referenced in Section 2.1.13.2 above, or if Smart City Communications elects not to utilize the EEL to Loop Retermination process, Smart City Communications must submit an LSR to disconnect the entire EEL circuit, and must submit a separate LSR for the requested standalone Loop. In such cases, Smart City Communications will be charged the EEL disconnect charges and the full nonrecurring rates for installation of a new Loop, as set forth in Exhibit A.

- 2.1.13.5 The EEL to Loop Retermination process and requirements will be handled in accordance with the guidelines set forth in the Ordering Guidelines and CLEC Information Packages as referenced in Sections 1.13.1 and 1.13.2 above.
- 2.2 Unbundled Voice Loops (UVLs)
- 2.2.1 BellSouth shall make available the following UVLs:
- 2.2.1.1 2-wire Analog Voice Grade Loop – SL1 (Non-Designed);
- 2.2.1.2 2-wire Analog Voice Grade Loop – SL2 (Designed); or
- 2.2.1.3 4-wire Analog Voice Grade Loop (Designed).
- 2.2.2 UVL may be provisioned using any type of facility that will support voice grade services. This may include loaded copper, non-loaded copper, digital loop carrier systems, fiber/copper combination (hybrid loop) or a combination of any of these facilities. BellSouth, in the normal course of maintaining, repairing, and configuring its network, may also change the facilities that are used to provide any given voice grade circuit. This change may occur at any time. In these situations, BellSouth will only ensure that the newly provided facility will support voice grade services. BellSouth will not guarantee that Smart City Communications will be able to continue to provide any advanced services over the new facility. BellSouth will offer UVL in two different service levels - Service Level One (SL1) and Service Level Two (SL2).
- 2.2.3 Unbundled Voice Loop - SL1 (UVL-SL1). Loops are 2-wire loop start circuits, will be non-designed, and will not have remote access test points. OC will be offered as a chargeable option on SL1 Loops when reuse of existing facilities has been requested by Smart City Communications, however, OC is always required on UCLs that involve the reuse of facilities that are currently providing service. Smart City Communications may also order OC-TS when a specified conversion time is requested. OC-TS is a chargeable option for any coordinated order and is billed in addition to the OC charge. An Engineering Information (EI) document can be ordered as a chargeable option. The EI document provides Loop Make-Up information which is similar to the information normally provided in a Design Layout Record (DLR). Upon issuance of a non-coordinated order in the service order system, SL1 Loops will be activated on the due date in the same manner and time frames that BellSouth normally activates POTS-type Loops for its customers.
- 2.2.4 For an additional charge BellSouth will make available Loop Testing so that Smart City Communications may request further testing on new UVL-SL1 Loops. Rates for Loop Testing are as set forth in Exhibit A.

- 2.2.5 Unbundled Voice Loop – SL2 (UVL-SL2). Loops may be 2-wire or 4-wire circuits, shall have remote access test points, and will be designed with a DLR provided to Smart City Communications. SL2 circuits can be provisioned with loop start, ground start or reverse battery signaling. OC is provided as a standard feature on SL2 Loops. The OC feature will allow Smart City Communications to coordinate the installation of the Loop with the disconnect of an existing customer's service and/or number portability service. In these cases, BellSouth will perform the order conversion with standard order coordination at its discretion during normal work hours.
- 2.3 Unbundled Digital Loops
- 2.3.1 BellSouth will offer UDLs. UDLs are service specific, will be designed, will be provisioned with test points (where appropriate), and will come standard with OC and a DLR. The various UDLs are intended to support a specific digital transmission scheme or service.
- 2.3.2 BellSouth shall make available the following UDLs, subject to restrictions set forth herein:
- 2.3.2.1 2-wire Unbundled ISDN Digital Loop;
- 2.3.2.2 2-wire Unbundled ADSL Compatible Loop;
- 2.3.2.3 2-wire Unbundled HDSL Compatible Loop;
- 2.3.2.4 4-wire Unbundled HDSL Compatible Loop;
- 2.3.2.5 4-wire Unbundled DS1 Digital Loop;
- 2.3.2.6 4-wire Unbundled Digital Loop/DS0 – 64 kbps, 56 kbps and below;
- 2.3.2.7 DS3 Loop; or
- 2.3.2.8 STS-1 Loop.
- 2.3.3 2-wire Unbundled ISDN Digital Loops. These will be provisioned according to industry standards for 2-Wire Basic Rate ISDN services and will come standard with a test point, OC, and a DLR. Smart City Communications will be responsible for providing BellSouth with a Service Profile Identifier (SPID) associated with a particular ISDN-capable Loop and customer. With the SPID, BellSouth will be able to adequately test the circuit and ensure that it properly supports ISDN service.
- 2.3.4 2-wire ADSL-Compatible Loop. This is a designed Loop that is provisioned according to Revised Resistance Design (RRD) criteria and may be up to eighteen

thousand (18,000) feet long and may have up to six thousand (6,000) feet of bridged tap (inclusive of Loop length). The Loop is a 2-wire circuit and will come standard with a test point, OC, and a DLR.

- 2.3.5 2-wire or 4-wire HDSL-Compatible Loop. This is a designed Loop that meets Carrier Serving Area (CSA) specifications, may be up to twelve thousand (12,000) feet long and may have up to twenty-five hundred (2,500) feet of bridged tap (inclusive of Loop length). It may be a 2-wire or 4-wire circuit and will come standard with a test point, OC, and a DLR.
- 2.3.6 4-wire Unbundled DS1 Digital Loop.
- 2.3.6.1 This is a designed 4-wire Loop that is provisioned according to industry standards for DS1 or Primary Rate ISDN services and will come standard with a test point, OC, and a DLR. A DS1 Loop may be provisioned over a variety of loop transmission technologies including copper, HDSL-based technology or fiber optic transport systems. It will include a 4-wire DS1 Network Interface at the customer's location. For the purposes of BellSouth's unbundling obligations pursuant to this Agreement, for the state of Florida, DS1 Loops include 2-wire and 4-wire copper Loops capable of providing high-bit rate digital subscriber line services, such as 2-wire and 4-wire HDSL Compatible Loops.
- 2.3.6.2 BellSouth shall not provide more than ten (10) unbundled DS1 Loops to Smart City Communications at any single building in which DS1 Loops are available as unbundled Loops.
- 2.3.6.2.1 For purposes of this Attachment 2, a "Building" is a permanent physical structure including, but not limited to, a structure in which people reside, or conduct business or work on a daily basis and through which there is one centralized point of entry in the structure through which all telecommunications services must transit. As an example only, a high rise office building with a general telecommunications equipment room through which all telecommunications services to that building's tenants must pass would be a single "building" for purposes of this Attachment 2. Two (2) or more physical areas served by individual points of entry through which telecommunications services must transit will be considered separate buildings. For instance, a strip mall with individual businesses obtaining telecommunication services from different access points on the building(s) will be considered individual buildings, even though they might share common walls.
- 2.3.7 4-wire Unbundled Digital/DS0 Loop. These are designed 4-wire Loops that may be configured as sixty-four (64)kbps, fifty-six (56)kbps, nineteen (19)kbps, and other sub-rate speeds associated with digital data services and will come standard with a test point, OC, and a DLR.

- 2.3.8 DS3 Loop. DS3 Loop is a two-point digital transmission path which provides for simultaneous two-way transmission of serial, bipolar, return-to-zero isochronous digital electrical signals at a transmission rate of forty-four point seven thirty-six (44.736) megabits per second (Mbps) that is dedicated to the use of the ordering CLEC. It may provide transport for twenty-eight (28) DS1 channels, each of which provides the digital equivalent of twenty-four (24) analog voice grade channels. The interface to unbundled dedicated DS3 transport is a metallic-based electrical interface. For the purpose of BellSouth's unbundling obligations pursuant to this Agreement, DS3 Loops include STS-1 Loops.
- 2.3.9 STS-1 Loop. STS-1 Loop is a high-capacity digital transmission path with SONET VT1.5 mapping that is dedicated for the use of the ordering customer. It is a two-point digital transmission path which provides for simultaneous two-way transmission of serial bipolar return-to-zero synchronous digital electrical signals at a transmission rate of fifty-one point eighty-four (51.84) Mbps. It may provide transport for twenty-eight (28) DS1 channels, each of which provides the digital equivalent of twenty-four (24) analog voice grade channels. The interface to unbundled dedicated STS-1 transport is a metallic-based electrical interface.
- 2.3.10 Both DS3 Loop and STS-1 Loop require a SI in order to ascertain availability.
- 2.3.11 DS3 services come with a test point and a DLR. Mileage is airline miles, rounded up and a minimum of one (1) mile applies. BellSouth's TR73501 LightGate<sup>®</sup> Service Interface and Performance Specifications, Issue D, June 1995 applies to DS3 services.
- 2.3.12 Smart City Communications may obtain a maximum of a single Unbundled DS3 Loop to any single building in which DS3 Loops are available as Unbundled Loops.
- 2.4 Unbundled Copper Loops (UCL).
- 2.4.1 BellSouth shall make available UCLs. The UCL is a copper twisted pair Loop that is unencumbered by any intervening equipment (e.g., filters, load coils, range extenders, digital loop carrier, or repeaters) and is not intended to support any particular telecommunications service. The UCL will be offered in two (2) types – Designed and Non-Designed.
- 2.4.2 Unbundled Copper Loop – Designed (UCL-D)
- 2.4.2.1 The UCL-D will be provisioned as a dry copper twisted pair (2-wire or 4-wire) Loop that is unencumbered by any intervening equipment (e.g., filters, load coils, range extenders, digital loop carrier, or repeaters).



- 2.4.2.2 A UCL-D will be eighteen thousand (18,000) feet or less in length and is provisioned according to Resistance Design parameters, may have up to six thousand (6,000) feet of bridged tap and will have up to thirteen hundred (1300) Ohms of resistance.
- 2.4.2.3 The UCL-D is a designed circuit, is provisioned with a test point, and comes standard with a DLR. OC is a chargeable option for a UCL-D; however, OC is always required on UCLs where a reuse of existing facilities has been requested by Smart City Communications.
- 2.4.2.4 These Loops are not intended to support any particular services and may be utilized by Smart City Communications to provide a wide-range of telecommunications services as long as those services do not adversely affect BellSouth's network. This facility will include a Network Interface Device (NID) at the customer's location for the purpose of connecting the Loop to the customer's inside wire.
- 2.4.3 Unbundled Copper Loop – Non-Designed (UCL-ND)
- 2.4.3.1 The UCL-ND is provisioned as a dedicated 2-wire metallic transmission facility from BellSouth's Main Distribution Frame (MDF) to a customer's premises (including the NID). The UCL-ND will be a "dry copper" facility in that it will not have any intervening equipment such as load coils, repeaters, or digital access main lines (DAMLs), and may have up to six thousand (6,000) feet of bridged tap between the customer's premises and the serving wire center. The UCL-ND typically will be thirteen hundred (1300) Ohms resistance and in most cases will not exceed eighteen thousand (18,000) feet in length, although the UCL-ND will not have a specific length limitation. For Loops less than eighteen thousand (18,000) feet and with less than thirteen hundred (1300) Ohms resistance, the Loop will provide a voice grade transmission channel suitable for loop start signaling and the transport of analog voice grade signals. The UCL-ND will not be designed and will not be provisioned with either a DLR or a test point.
- 2.4.3.2 The UCL-ND facilities may be mechanically assigned using BellSouth's assignment systems. Therefore, the Loop Makeup (LMU) process is not required to order and provision the UCL-ND. However, Smart City Communications can request LMU for which additional charges would apply.
- 2.4.3.3 For an additional charge, BellSouth also will make available Loop Testing so that Smart City Communications may request further testing on the UCL-ND. Rates for Loop Testing are as set forth in Exhibit A.
- 2.4.3.4 UCL-ND Loops are not intended to support any particular service and may be utilized by Smart City Communications to provide a wide-range of telecommunications services as long as those services do not adversely affect

BellSouth's network. The UCL-ND will include a NID at the customer's location for the purpose of connecting the Loop to the customer's inside wire.

2.4.3.5 OC will be provided as a chargeable option and may be utilized when the UCL-ND provisioning is associated with the reuse of BellSouth facilities. OC-TS does not apply to this product.

2.4.3.6 Smart City Communications may use BellSouth's Unbundled Loop Modification (ULM) offering to remove excessive bridged taps and/or load coils from any copper Loop within the BellSouth network. Therefore, some Loops that would not qualify as UCL-ND could be transformed into Loops that do qualify, using the ULM process.

## 2.5 Unbundled Loop Modifications (Line Conditioning)

2.5.1 Line Conditioning is defined as routine network modification that BellSouth regularly undertakes to provide xDSL services to its own customers. This may include the removal of any device, from a copper Loop or copper Subloop that may diminish the capability of the Loop or Subloop to deliver high-speed switched wireline telecommunications capability, including xDSL service. Such devices include, load coils, excessive bridged taps, low pass filters, and range extenders. Excessive bridged taps are bridged taps that serves no network design purpose and that are beyond the limits set according to industry standards and/or the BellSouth's TR 73600 Unbundled Local Loop Technical Specification. BellSouth shall provide Line Conditioning on Loops, as requested by Smart City Communications, even in instances where BellSouth does not provide advanced services to the end user on that Loop.

2.5.2 BellSouth will remove load coils only on copper Loops that are equal to or less than eighteen thousand (18,000) feet in length. BellSouth will remove load coils on copper Subloops where the total loop distance (feeder plus distribution) from the BellSouth central office to the end user is equal to or less than 18,000 feet or, if there is no copper feeder, the distance from the remote terminal (RT) to the end user is equal to or less than 18,000 feet.

2.5.3 For any copper loop being ordered by Smart City Communications which has over six thousand (6,000) feet of combined bridged tap will be modified, upon request from Smart City Communications, so that the loop will have a maximum of six thousand (6,000) feet of bridged tap. This modification will be performed at no additional charge to Smart City Communications. Loop conditioning orders that require the removal of bridged tap that serves no network design purpose on a copper Loop that will result in a combined total of bridged tap between two thousand five hundred (2,500) and six thousand (6,000) feet will be performed at the rates set forth in Exhibit A.

- 2.5.4 Smart City Communications may request removal of any unnecessary and non-excessive bridged tap (bridged tap between zero (0) and two thousand five hundred (2,500) feet which serves no network design purpose), at rates pursuant to BellSouth's SC Process as mutually agreed to by the Parties.
- 2.5.5 Rates for ULM are as set forth in Exhibit A.
- 2.5.6 BellSouth will not modify a Loop in such a way that it no longer meets the technical parameters of the original Loop type (e.g., voice grade, ADSL, etc.) being ordered.
- 2.5.7 If Smart City Communications requests ULM on a reserved facility for a new Loop order, BellSouth may perform a pair change and provision a different Loop facility in lieu of the reserved facility with ULM if feasible. The Loop provisioned will meet or exceed specifications of the requested Loop facility as modified. Smart City Communications will not be charged for ULM if a different Loop is provisioned. For Loops that require a DLR or its equivalent, BellSouth will provide LMU detail of the Loop provisioned.
- 2.5.8 Smart City Communications shall request Loop make up information pursuant to this Attachment prior to submitting a service inquiry and/or a LSR for the Loop type that Smart City Communications desires BellSouth to condition.
- 2.5.9 When requesting ULM for a Loop that BellSouth has previously provisioned for Smart City Communications, Smart City Communications will submit a SI to BellSouth. If a spare Loop facility that meets the Loop modification specifications requested by Smart City Communications is available at the location for which the ULM was requested, Smart City Communications will have the option to change the Loop facility to the qualifying spare facility rather than to provide ULM. In the event that BellSouth changes the Loop facility in lieu of providing ULM, Smart City Communications will not be charged for ULM but will only be charged the service order charges for submitting an order.
- 2.6 Loop Provisioning Involving IDLC
- 2.6.1 Where Smart City Communications has requested an Unbundled Loop and BellSouth uses IDLC systems to provide the local service to the customer and BellSouth has a suitable alternate facility available, BellSouth will make such alternative facilities available to Smart City Communications. If a suitable alternative facility is not available, then to the extent it is technically feasible, BellSouth will implement one of the following alternative arrangements for Smart City Communications (e.g., hairpinning):
1. Roll the circuit(s) from the IDLC to any spare copper that exists to the customer premises.
  2. Roll the circuit(s) from the IDLC to an existing DLC that is not integrated.

3. If capacity exists, provide "side-door" porting through the switch.
4. If capacity exists, provide "Digital Access Cross-Connect System (DACS)-door" porting (if the IDLC routes through a DACS prior to integration into the switch).

2.6.2 Arrangements 3 and 4 above require the use of a designed circuit. Therefore, non-designed Loops such as the SL1 voice grade and UCL-ND may not be ordered in these cases.

2.6.2.1 If no alternate facility is available, and upon request from Smart City Communications, and if agreed to by both Parties, BellSouth may utilize its SC process to determine the additional costs required to provision facilities. Smart City Communications will then have the option of paying the one-time SC rates to place the Loop.

## 2.7 Network Interface Device

2.7.1 The NID is defined as any means of interconnection of the customer's customer premises wiring to BellSouth's distribution plant, such as a cross-connect device used for that purpose. The NID is a single line termination device or that portion of a multiple line termination device required to terminate a single line or circuit at the premises. The NID features two (2) independent chambers or divisions that separate the service provider's network from the customer's premises wiring. Each chamber or division contains the appropriate connection points or posts to which the service provider and the customer each make their connections. The NID provides a protective ground connection and is capable of terminating cables such as twisted pair cable.

2.7.2 BellSouth shall permit Smart City Communications to connect Smart City Communications's Loop facilities to the customer's customer premises wiring through the BellSouth NID or at any other technically feasible point.

### 2.7.3 Access to NID

2.7.3.1 Smart City Communications may access the customer's premises wiring by any of the following means and Smart City Communications shall not disturb the existing form of electrical protection and shall maintain the physical integrity of the NID:

2.7.3.1.1 BellSouth shall allow Smart City Communications to connect its Loops directly to BellSouth's multi-line residential NID enclosures that have additional space and are not used by BellSouth or any other telecommunications carriers to provide service to the premises;

2.7.3.1.2 Where an adequate length of the customer's customer premises wiring is present and environmental conditions permit, either Party may remove the customer

premises wiring from the other Party's NID and connect such wiring to that Party's own NID;

- 2.7.3.1.3 Either Party may enter the subscriber access chamber or dual chamber NID enclosures for the purpose of extending a cross-connect or spliced jumper wire from the customer premises wiring through a suitable "punch-out" hole of such NID enclosures; or
- 2.7.3.1.4 Smart City Communications may request BellSouth to make other rearrangements to the customer premises wiring terminations or terminal enclosure on a time and materials cost basis.
- 2.7.3.2 In no case shall either Party remove or disconnect the other Party's loop facilities from either Party's NIDs, enclosures, or protectors unless the applicable Commission has expressly permitted the same and the disconnecting Party provides prior notice to the other Party. In such cases, it shall be the responsibility of the Party disconnecting loop facilities to leave undisturbed the existing form of electrical protection and to maintain the physical integrity of the NID. It will be Smart City Communications's responsibility to ensure there is no safety hazard, and Smart City Communications will hold BellSouth harmless for any liability associated with the removal of the BellSouth Loop from the BellSouth NID. Furthermore, it shall be the responsibility of the disconnecting Party, once the other Party's loop has been disconnected from the NID, to reconnect the disconnected loop to a nationally recognized testing laboratory listed station protector, which has been grounded as per Article 800 of the National Electrical Code. If no spare station protector exists in the NID, the disconnected loop must be appropriately cleared, capped and stored.
- 2.7.3.3 Smart City Communications shall not remove or disconnect ground wires from BellSouth's NIDs, enclosures, or protectors.
- 2.7.3.4 Smart City Communications shall not remove or disconnect NID modules, protectors, or terminals from BellSouth's NID enclosures.
- 2.7.3.5 Due to the wide variety of NID enclosures and outside plant environments, BellSouth will work with Smart City Communications to develop specific procedures to establish the most effective means of implementing this section if the procedures set forth herein do not apply to the NID in question.
- 2.7.4 Technical Requirements
- 2.7.4.1 The NID shall provide an accessible point of interconnection and shall maintain a connection to ground.

- 2.7.4.2 If an existing NID is accessed, it shall be capable of transferring electrical analog or digital signals between the customer's customer premises and the distribution media and/or cross-connect to Smart City Communications's NID.
- 2.7.4.3 Existing BellSouth NIDs will be operational and provided in "as is" condition. Smart City Communications may request BellSouth to do additional work to the NID on a time and material basis. When Smart City Communications deploys its own local loops in a multiple-line termination device, Smart City Communications shall specify the quantity of NID connections that it requires within such device.
- 2.8 Subloop Distribution Elements.
- 2.8.1 Where facilities permit, BellSouth shall offer access to its Unbundled Subloop Distribution (USLD) elements in accordance with 47 C.F.R. § 51.319(b) as specified herein.
- 2.8.2 Unbundled Subloop Distribution
- 2.8.2.1 The USLD facility is a dedicated transmission facility that BellSouth provides from a customer's point of demarcation to a BellSouth cross-connect device. The BellSouth cross-connect device may be located within a remote terminal (RT) or a stand-alone cross-box in the field or in the equipment room of a building. The USLD media is a copper twisted pair that can be provisioned as a 2-wire or 4-wire facility. BellSouth will make available the following subloop distribution offerings where facilities exist:
- USLD – Voice Grade (USLD-VG)
  - Unbundled Copper Subloop (UCSL)
  - USLD – Intrabuilding Network Cable (USLD-INC (aka riser cable))
- 2.8.2.2 USLD-VG is a copper subloop facility from the cross-box in the field up to and including the point of demarcation at the customer's premises and may have load coils.
- 2.8.2.3 UCSL is a copper facility eighteen thousand (18,000) feet or less in length provided from the cross-box in the field up to and including the customer's point of demarcation. If available, this facility will not have any intervening equipment such as load coils between the customer and the cross-box.
- 2.8.2.3.1 If Smart City Communications requests a UCSL and it is not available, Smart City Communications may request the copper Subloop facility be modified pursuant to the ULM process to remove load coils and/or excessive bridged taps. If load coils and/or excessive bridged taps are removed, the facility will be classified as a UCSL.

- 2.8.2.4 USLD-INC is the distribution facility owned or controlled by BellSouth inside a building or between buildings on the same property that is not separated by a public street or road. USLD-INC includes the facility from the cross-connect device in the building equipment room up to and including the point of demarcation at the customer's premises.
- 2.8.2.4.1 Upon request for USLD-INC from Smart City Communications, BellSouth will install a cross-connect panel in the building equipment room for the purpose of accessing USLD-INC pairs from a building equipment room. The cross-connect panel will function as a single point of interconnection (SPOI) for USLD-INC and will be accessible by multiple carriers as space permits. BellSouth will place cross-connect blocks in twenty five (25) pair increments for Smart City Communications's use on this cross-connect panel. Smart City Communications will be responsible for connecting its facilities to the twenty five (25) pair cross-connect block(s).
- 2.8.2.5 For access to Voice Grade USLD and UCSL, Smart City Communications shall install a cable to the BellSouth cross-box pursuant to the terms and conditions for physical collocation for remote sites set forth in Attachment 4. This cable would be connected by a BellSouth technician within the BellSouth cross-box during the set-up process. Smart City Communications's cable pairs can then be connected to BellSouth's USL within the BellSouth cross-box by the BellSouth technician.
- 2.8.2.6 Through the SI process, BellSouth will determine whether access to USLs at the location requested by Smart City Communications is technically feasible and whether sufficient capacity exists in the cross-box. If existing capacity is sufficient to meet Smart City Communications's request, then BellSouth will perform the site set-up as described in the CLEC Information Package, located at BellSouth's Interconnection Web site.
- 2.8.2.7 The site set-up must be completed before Smart City Communications can order Subloop pairs. For the site set-up in a BellSouth cross-connect box in the field, BellSouth will perform the necessary work to splice Smart City Communications's cable into the cross-connect box. For the site set-up inside a building equipment room, BellSouth will perform the necessary work to install the cross-connect panel and the connecting block(s) that will be used to provide access to the requested USLs.
- 2.8.2.8 Once the site set-up is complete, Smart City Communications will request Subloop pairs through submission of a LSR form to the LCSC. OC is required with USL pair provisioning when Smart City Communications requests reuse of an existing facility, and the OC charge shall be billed in addition to the USL pair rate. For expedite requests by Smart City Communications for Subloop pairs, expedite charges will apply for intervals less than five (5) days.

- 2.8.2.9 USLs will be provided in accordance with BellSouth's TR 73600 Unbundled Local Loop Technical Specifications.
- 2.8.3 Unbundled Network Terminating Wire (UNTW)
- 2.8.3.1 UNTW is unshielded twisted copper wiring that is used to extend circuits from an intra-building network cable terminal or from a building entrance terminal to an individual customer's point of demarcation. It is the final portion of the Loop that in multi-subscriber configurations represents the point at which the network branches out to serve individual subscribers.
- 2.8.3.2 This element will be provided in MDUs and/or Multi-Tenants Units (MTUs) where either Party owns wiring all the way to the customer's premises. Neither Party will provide this element in locations where the property owner provides its own wiring to the customer's premises, where a third party owns the wiring to the customer's premises.
- 2.8.3.3 Requirements
- 2.8.3.3.1 On a multi-unit premises, upon request of the other Party (Requesting Party), the Party owning the network terminating wire (Provisioning Party) will provide access to UNTW pairs on an Access Terminal that is suitable for use by multiple carriers at each Garden Terminal or Wiring Closet.
- 2.8.3.3.2 The Provisioning Party shall not be required to install new or additional NTW beyond existing NTW to provision the services of the Requesting Party.
- 2.8.3.3.3 In existing MDUs and/or MTUs in which BellSouth does not own or control wiring (INC/NTW) to the customers premises, and Smart City Communications does own or control such wiring, Smart City Communications will install UNTW Access Terminals for BellSouth under the same terms and conditions as BellSouth provides UNTW Access Terminals to Smart City Communications.
- 2.8.3.3.4 In situations in which BellSouth activates a UNTW pair, BellSouth will compensate Smart City Communications for each pair activated commensurate to the price specified in Smart City Communications's Agreement.
- 2.8.3.3.5 Upon receipt of the UNTW SI requesting access to the Provisioning Party's UNTW pairs at a multi-unit premises, representatives of both Parties will participate in a meeting at the site of the requested access. The purpose of the site visit will include discussion of the procedures for installation and location of the Access Terminals. By request of the Requesting Party, an Access Terminal will be installed either adjacent to each of the Provisioning Party's Garden Terminal or inside each Wiring Closet. The Requesting Party will deliver and connect its central office facilities to the UNTW pairs within the Access Terminal. The



Requesting Party may access any available pair on an Access Terminal. A pair is available when a pair is not being utilized to provide service or where the customer has requested a change in its local service provider to the Requesting Party. Prior to connecting the Requesting Party's service on a pair previously used by the Provisioning Party, the Requesting Party is responsible for ensuring the customer is no longer using the Provisioning Party's service or another CLEC's service before accessing UNTW pairs.

- 2.8.3.3.6 Access Terminal installation intervals will be established on an individual case basis.
- 2.8.3.3.7 The Requesting Party is responsible for obtaining the property owner's permission for the Provisioning Party to install an Access Terminal(s) on behalf of the Requesting Party. The submission of the SI by the Requesting Party will serve as certification by the Requesting Party that such permission has been obtained. If the property owner objects to Access Terminal installations that are in progress or within thirty (30) days after completion and demands removal of Access Terminals, the Requesting Party will be responsible for costs associated with removing Access Terminals and restoring the property to its original state prior to Access Terminals being installed.
- 2.8.3.3.8 The Requesting Party shall indemnify and hold harmless the Provisioning Party against any claims of any kind that may arise out of the Requesting Party's failure to obtain the property owner's permission. The Requesting Party will be billed for nonrecurring and recurring charges for accessing UNTW pairs at the time the Requesting Party activates the pair(s). The Requesting Party will notify the Provisioning Party within five (5) business days of activating UNTW pairs using the LSR form.
- 2.8.3.3.9 If a trouble exists on a UNTW pair, the Requesting Party may use an alternate spare pair that serves that customer if a spare pair is available. In such cases, the Requesting Party will re-terminate its existing jumper from the defective pair to the spare pair. Alternatively, the Requesting Party will isolate and report troubles in the manner specified by the Provisioning Party. The Requesting Party must tag the UNTW pair that requires repair. If the Provisioning Party dispatches a technician on a reported trouble call and no UNTW trouble is found, the Provisioning Party will charge Requesting Party for time spent on the dispatch and testing the UNTW pair(s).
- 2.8.3.3.10 If the Requesting Party initiates the Access Terminal installation and the Requesting Party has not activated at least ten percent (10%) of the capacity of the Access Terminal installed pursuant to the Requesting Party's request for an Access Terminal within six (6) months of installation of the Access Terminal, the Provisioning Party will bill the Requesting Party a nonrecurring charge equal to the actual cost of provisioning the Access Terminal.

2.8.3.3.11 If the Provisioning Party determines that the Requesting Party is using the UNTW pairs without reporting the activation of the pairs, the Requesting Party will be billed for the use of that pair back to the date the customer began receiving service from the Requesting Party at that location. Upon request, the Requesting Party will provide copies of its billing record to substantiate such date. If the Requesting Party fails to provide such records, then the Provisioning Party will bill the Requesting Party back to the date of the Access Terminal installation.

2.9 Loop Makeup

2.9.1 Description of Service

2.9.1.1 BellSouth shall make available to Smart City Communications LMU information with respect to Loops that are required to be unbundled under this Agreement so that Smart City Communications can make an independent judgment about whether the Loop is capable of supporting the advanced services equipment Smart City Communications intends to install and the services Smart City Communications wishes to provide. LMU is a preordering transaction, distinct from Smart City Communications ordering any other service(s). Loop Makeup Service Inquiries (LMUSI) and mechanized LMU queries for preordering LMU are likewise unique from other preordering functions with associated SIs as described in this Agreement.

2.9.1.2 BellSouth will provide Smart City Communications LMU information consisting of the composition of the Loop material (copper/fiber); the existence, location and type of equipment on the Loop, including but not limited to digital loop carrier or other remote concentration devices, feeder/distribution interfaces, bridged taps, load coils, pair-gain devices; the Loop length; the wire gauge and electrical parameters.

2.9.1.3 BellSouth's LMU information is provided to Smart City Communications as it exists either in BellSouth's databases or in its hard copy facility records. BellSouth does not guarantee accuracy or reliability of the LMU information provided.

2.9.1.4 BellSouth's provisioning of LMU information to the requesting CLEC for facilities is contingent upon either BellSouth or the requesting CLEC controlling the Loop(s) that serve the service location for which LMU information has been requested by the CLEC. The requesting CLEC is not authorized to receive LMU information on a facility used or controlled by another CLEC unless BellSouth receives a LOA from the voice CLEC (owner) or its authorized agent on the LMUSI submitted by the requesting CLEC.

2.9.1.5 Smart City Communications may choose to use equipment that it deems will enable it to provide a certain type and level of service over a particular BellSouth Loop as long as that equipment does not disrupt other services on the BellSouth

network. The determination shall be made solely by Smart City Communications and BellSouth shall not be liable in any way for the performance of the advanced data services provisioned over said Loop. The specific Loop type (e.g., ADSL, HDSL, or otherwise) ordered on the LSR must match the LMU of the Loop reserved taking into consideration any requisite line conditioning. The LMU data is provided for informational purposes only and does not guarantee Smart City Communications's ability to provide advanced data services over the ordered Loop type. Furthermore, the LMU information for Loops other than copper-only Loops (e.g., ADSL, UCL-ND, etc.) that support xDSL services, is subject to change at any time due to modifications and/or upgrades to BellSouth's network. Except as set forth in Section 2.9.1.6 below, copper-only Loops will not be subject to change due to modification and/or upgrades to BellSouth's network and will remain on copper facilities until the Loop is disconnected by Smart City Communications or the customer, or until BellSouth retires the copper facilities via the FCC's and any applicable Commission's requirements. Smart City Communications is fully responsible for any of its service configurations that may differ from BellSouth's technical standard for the Loop type ordered.

2.9.1.6 If BellSouth retires its copper facilities using 47 C.F.R § 51.325(a) requirements; or is required by a governmental agency or regulatory body to move or replace copper facilities as a maintenance procedure, BellSouth will notify Smart City Communications, according to the applicable network disclosure requirements. It will be Smart City Communications's responsibility to move any service it may provide over such facilities to alternative facilities. If Smart City Communications fails to move the service to alternative facilities by the date in the network disclosure notice, BellSouth may terminate the service to complete the network change.

2.9.2 Submitting LMUSI

2.9.2.1 Smart City Communications may obtain LMU information and reserve facilities by submitting a mechanized LMU query or a manual LMUSI according to the terms and conditions as described in the LMU CLEC Information Package, incorporated herein by reference as it may be amended from time to time. The CLEC Information Package is located at the "CLEC UNE Product" on BellSouth's Interconnection Web site. After obtaining the Loop information from the mechanized LMU process, if Smart City Communications needs further Loop information in order to determine Loop service capability, Smart City Communications may initiate a separate Manual SI for a separate nonrecurring charge as set forth in Exhibit A.

2.9.2.2 All LSRs issued for reserved facilities shall reference the facility reservation number as provided by BellSouth. Smart City Communications will not be billed any additional LMU charges for the Loop ordered on such LSR. If, however, Smart City Communications does not reserve facilities upon an initial LMUSI,

Smart City Communications's placement of an order for an advanced data service type facility will incur the appropriate billing charges to include SI and reservation per Exhibit A.

- 2.9.2.3 Where Smart City Communications has reserved multiple Loop facilities on a single reservation, Smart City Communications may not specify which facility shall be provisioned when submitting the LSR. For those occasions, BellSouth will assign to Smart City Communications, subject to availability, a facility that meets the BellSouth technical standards of the BellSouth type Loop as ordered by Smart City Communications.
- 2.9.2.4 Charges for preordering manual LMUSI or mechanized LMU are separate from any charges associated with ordering other services from BellSouth.

### **3 Line Splitting**

- 3.1 Line splitting shall mean that a provider of data services (a Data LEC) and a provider of voice services (a Voice CLEC) to deliver voice and data service to customers over the same Loop. The Voice CLEC and Data LEC may be the same or different carriers. BellSouth will provide Line Splitting over a Loop (UNE-L) purchased by Smart City Communications pursuant to this Agreement.
- 3.2 Line Splitting – UNE-L. In the event Smart City Communications provides its own switching or obtains switching from a third party, Smart City Communications may engage in line splitting arrangements with another CLEC using a splitter, provided by Smart City Communications, in a Collocation Space at the central office where the loop terminates into a distribution frame or its equivalent.
- 3.3 BellSouth must make all necessary network modifications, including providing nondiscriminatory access to OSS necessary for pre-ordering, ordering, provisioning, maintenance and repair, and billing for Loops used in line splitting arrangements. The Parties may use the Change Control Process to address necessary OSS modifications.
- 3.4 Provisioning Line Splitting – UNE-L
- 3.4.1 The Voice CLEC provides the splitter when providing Line Splitting with UNE-L. When Smart City Communications owns the splitter, Line Splitting requires the following: a loop from NID at the customer's location to the serving wire center and terminating into a distribution frame or its equivalent.
- 3.4.2 An unloaded 2-wire copper Loop must serve the customer. The meet point for the Voice CLEC and the Data LEC is the point of termination on the MDF for the Data LEC's cable and pairs.

- 3.4.3 To order Line Splitting utilizing UNE-L on a particular Loop, Smart City Communications must have a DSLAM collocated in the central office that serves the customer of such Loop.
- 3.4.4 Smart City Communications may purchase, install and maintain central office POTS splitters in its collocation arrangements. Smart City Communications may use such splitters for access to its customers and to provide digital line subscriber services to its customers using the high frequency spectrum of the UNE-L. Existing Collocation rules and procedures and the terms and conditions relating to Collocation set forth in Attachment 4-Central Office shall apply.
- 3.5 Maintenance – Line Splitting – UNE-L
- 3.5.1 BellSouth will be responsible for repairing voice troubles and the troubles with the physical loop between the NID at the customer’s premises and the termination point.
- 3.5.2 Smart City Communications shall indemnify, defend and hold harmless BellSouth from and against any claims, losses, actions, causes of action, suits, demands, damages, injury, and costs including reasonable attorney fees, which arise out of actions related to the other service provider, except to the extent caused by BellSouth’s gross negligence or willful misconduct.

#### **4 Unbundled Network Element Combinations**

- 4.1 For purposes of this Section, references to “Currently Combined” Network Elements shall mean that the particular Network Elements requested by Smart City Communications are in fact already combined by BellSouth in the BellSouth network. References to “Ordinarily Combined” Network Elements shall mean that the particular Network Elements requested by Smart City Communications are not already combined by BellSouth in the location requested by Smart City Communications but are elements that are typically combined in BellSouth’s network. References to “Not Typically Combined” Network Elements shall mean that the particular Network Elements requested by Smart City Communications are not elements that BellSouth combines for its use in its network.
- 4.1.1 Except as otherwise set forth in this Agreement, upon request, BellSouth shall perform the functions necessary to combine Network Elements that BellSouth is required to provide under this Agreement in any manner, even if those elements are not ordinarily combined in BellSouth’s network, provided that such Combination is technically feasible and will not undermine the ability of other carriers to obtain access to Network Elements or to interconnect with BellSouth’s network.

- 4.1.2 To the extent Smart City Communications requests a Combination for which BellSouth does not have methods and procedures in place to provide such Combination, rates and/or methods or procedures for such Combination will be developed pursuant to the BFR process.
- 4.2 Rates
- 4.2.1 The rates for the Currently Combined Network Elements specifically set forth in Exhibit A shall be the rates associated with such Combinations. Where a Currently Combined Combination is not specifically set forth in Exhibit A, the rate for such Currently Combined Combination shall be the sum of the recurring rates for those individual Network Elements as set forth in Exhibit A and/or Exhibit B in addition to the applicable nonrecurring switch-as-is charge set forth in Exhibit A.
- 4.2.2 The rates for the Ordinarily Combined Network Elements specifically set forth in Exhibit A shall be the nonrecurring and recurring charges for those Combinations. Where an Ordinarily Combined Combination is not specifically set forth in Exhibit A, the rate for such Ordinarily Combined Combination shall be the sum of the recurring rates for those individual Network Elements as set forth in Exhibit A and/or Exhibit B and nonrecurring rates for those individual Network Elements as set forth in Exhibit A.
- 4.2.3 The rates for Not Typically Combined Combinations shall be developed pursuant to the BFR process upon request of Smart City Communications.
- 4.3 Enhanced Extended Links (EELs)
- 4.3.1 EELs are combinations of Loops and Dedicated Transport as defined in this Attachment, together with any facilities, equipment, or functions necessary to combine those Network Elements. BellSouth shall provide Smart City Communications with EELs where the underlying Network Element are available and are required to be provided pursuant to this Agreement and in all instances where the requesting carrier meets the eligibility requirements, if applicable.
- 4.3.2 High-capacity EELs are (1) combinations of Loop and Dedicated Transport, (2) Dedicated Transport commingled with a wholesale loop, or (3) a loop commingled with wholesale transport at the DS1 and/or DS3 level as described in 47 C.F.R. § 51.318(b).
- 4.3.3 By placing an order for a high-capacity EEL, Smart City Communications thereby certifies that the service eligibility criteria set forth herein are met for access to a converted high-capacity EEL, a new high-capacity EEL, or part of a high-capacity commingled EEL as a Network Element. BellSouth shall have the right to audit Smart City Communications's high-capacity EELs as specified below.

4.3.4 Service Eligibility Criteria

4.3.4.1 High capacity EELs must comply with the following service eligibility requirements. Smart City Communications must certify for each high-capacity EEL that all of the following service eligibility criteria are met:

4.3.4.1.1 Smart City Communications has received state certification to provide local voice service in the area being served;

4.3.4.2 For each combined circuit, including each DS1 circuit, each DS1 EEL, and each DS1-equivalent circuit on a DS3 EEL:

4.3.4.2.1 1) Each circuit to be provided to each customer will be assigned a local number prior to the provision of service over that circuit;

4.3.4.2.2 2) Each DS1-equivalent circuit on a DS3 EEL must have its own local number assignment so that each DS3 must have at least twenty-eight (28) local voice numbers assigned to it;

4.3.4.2.3 3) Each circuit to be provided to each customer will have 911 or E911 capability prior to provision of service over that circuit;

4.3.4.2.4 4) Each circuit to be provided to each customer will terminate in a collocation arrangement that meets the requirements of 47 C.F.R. § 51.318(c);

4.3.4.2.5 5) Each circuit to be provided to each customer will be served by an interconnection trunk over which Smart City Communications will transmit the calling party's number in connection with calls exchanged over the trunk;

4.3.4.2.6 6) For each twenty-four (24) DS1 EELs or other facilities having equivalent capacity, Smart City Communications will have at least one (1) active DS1 local service interconnection trunk over which Smart City Communications will transmit the calling party's number in connection with calls exchanged over the trunk; and

4.3.4.2.7 7) Each circuit to be provided to each customer will be served by a switch capable of switching local voice traffic.

4.3.4.3 BellSouth may, on an annual basis, audit Smart City Communications's records in order to verify compliance with the qualifying service eligibility criteria. To invoke the audit, BellSouth will send a Notice of Audit to Smart City Communications. Such Notice of Audit will be delivered to Smart City Communications no less than thirty (30) days prior to the date upon which BellSouth seeks to commence an audit.

4.3.4.3.1 Such Notice of Audit to Smart City Communications shall state BellSouth's concern that Smart City Communications is not complying with the service

eligibility requirements as set forth above and a concise statement of the reasons therefor. BellSouth is not required to provide documentation, as distinct from a statement of concern, to support its basis for an audit, or seek the concurrence of the requesting carrier before selecting the location of the audit. BellSouth may select the independent auditor without the prior approval of Smart City Communications or the Commission. Challenges to the independence of the auditor may be filed with the Commission only after the audit has been concluded.

- 4.3.4.4 The audit shall be conducted by a third party independent auditor, and the audit must be performed in accordance with the standards established by the American Institute for Certified Public Accountants (AICPA) which will require the auditor to perform an “examination engagement” and issue a report regarding Smart City Communications’s compliance with the high capacity EEL eligibility criteria. AICPA standards and other AICPA requirements will be used to determine the independence of an auditor. The independent auditor’s report will conclude whether Smart City Communications complied in all material respects with the applicable service eligibility criteria. Consistent with standard auditing practices, such audits require compliance testing designed by the independent auditor.
- 4.3.4.5 To the extent the independent auditor’s report concludes that Smart City Communications failed to comply with the service eligibility criteria, Smart City Communications must true-up any difference in payments, convert all noncompliant circuits to the appropriate service, and make the correct payments on a going-forward basis. In the event the auditor’s report concludes that Smart City Communications did not comply in any material respect with the service eligibility criteria, Smart City Communications shall reimburse BellSouth for the cost of the independent auditor. To the extent the auditor’s report concludes that Smart City Communications did comply in all material respects with the service eligibility criteria, BellSouth will reimburse Smart City Communications for its reasonable and demonstrable costs associated with the audit. Smart City Communications will maintain appropriate documentation to support its certifications. The Parties shall provide such reimbursement within thirty (30) days of receipt of a statement of such costs.
- 4.3.4.6 In the event Smart City Communications converts special access services to Network Elements, Smart City Communications shall be subject to the termination liability provisions in the applicable special access tariffs, if any.

## **5 Dedicated Transport and Dark Fiber Transport**

- 5.1 Dedicated Transport. Dedicated Transport is defined as BellSouth’s transmission facilities between wire centers or switches owned by BellSouth, or between wire centers or switches owned by BellSouth and switches owned by Smart City Communications, including but not limited to DS1, DS3 and OCn level services, as well as dark fiber, dedicated to Smart City Communications. BellSouth shall not



be required to provide access to OCn level Dedicated Transport under any circumstances pursuant to this Agreement.

5.2 DS1 and DS3 Dedicated Transport Requirements

5.2.1 For purposes of this Section 5.2, a Business Line is as defined in 47 C.F.R. § 51.5.

5.2.2 Notwithstanding anything to the contrary in this Agreement, BellSouth shall make available Dedicated Transport as described in this Agreement, except in any wire center meeting the criteria described below:

5.2.2.1 DS1 Dedicated Transport where both wire centers at the end points of the route contain thirty-eight thousand (38,000) or more Business Lines or four (4) or more fiber-based collocators.

5.2.2.2 DS3 Dedicated Transport where both wire centers at the end points of the route contain twenty-four thousand (24,000) or more Business Lines or three (3) or more fiber-based collocators.

5.2.2.3 The Master List of Unimpaired Wire Centers and BellSouth's List of Unimpaired Wire Centers, as described in Section 1.8, sets forth the list of wire centers meeting the criteria set forth in Sections 5.2.2.1 and 5.2.2.2 above as of March 11, 2005.

5.2.2.4 Once a wire center meets or exceeds either of the thresholds set forth in Section 5.2.2.1 above, no future DS1 Dedicated Transport unbundling will be required between that wire center and any other wire center exceeding these same thresholds.

5.2.2.5 Once a wire center meets or exceeds either of the thresholds set forth in Section 5.2.2.2 above, no future DS3 Dedicated Transport will be required between that wire center and any other wire center meeting or exceeding these same thresholds.

5.2.2.6 Modifications and Updates to the Wire Center List and Subsequent Transition Periods

5.2.2.6.1 In the event BellSouth identifies additional wire centers that meet the criteria set forth in Sections 5.2.2.1 or 5.2.2.2 above, but that were not included in the Master List of Unimpaired Wire Centers or BellSouth's List of Unimpaired Wire Centers, BellSouth shall include such additional wire centers in a CNL. Each such list of additional wire centers shall be considered a Subsequent Wire Center List. BellSouth will follow any notification procedures set forth in applicable Commission orders.

5.2.2.6.2 Smart City Communications shall have thirty (30) business days to dispute the additional wire centers listed on BellSouth's CNL. Absent such dispute, effective

thirty (30) business days after the date of a BellSouth CNL providing a Subsequent Wire Center List, BellSouth shall not be required to provide DS1 and DS3 Dedicated Transport, as applicable, in such additional wire center(s), except pursuant to the self-certification process as set forth in Section 1.8 of this Attachment.

- 5.2.2.6.3 For purposes of Section 5.2.2.6 above, BellSouth shall make available DS1 and DS3 Dedicated Transport that were in service for Smart City Communications in a wire center on the Subsequent Wire Center List as of the thirtieth (30<sup>th</sup>) business day after the date of BellSouth's CNL identifying the Subsequent Wire Center List (Subsequent Embedded Base) until one hundred eighty (180) days after the thirtieth (30<sup>th</sup>) business day from the date of BellSouth's CNL identifying the Subsequent Wire Center List (Subsequent Transition Period).
- 5.2.2.6.4 The rates set forth in Exhibit B shall apply to the Subsequent Embedded Base during the Subsequent Transition Period.
- 5.2.2.6.5 No later than one hundred eighty (180) days from BellSouth's CNL identifying the Subsequent Wire Center List, Smart City Communications shall submit an LSR(s) or spreadsheet(s) as applicable, identifying the Subsequent Embedded Base of circuits to be disconnected or converted to other BellSouth services.
- 5.2.2.6.6 In the case of disconnection, the applicable disconnect charges set forth in this Agreement shall apply.
- 5.2.2.6.6.1 If Smart City Communications fails to submit the LSR(s) or spreadsheet(s) for all of its Subsequent Embedded Base by one hundred eighty (180) days after the date of BellSouth's CNL identifying the Subsequent Wire Center List, BellSouth will identify Smart City Communications's remaining Subsequent Embedded Base, if any, and will transition such circuits to the equivalent tariffed BellSouth service(s). In the state of Florida, those circuits identified and transitioned by BellSouth shall be subject to the applicable disconnect charges as set forth in this Agreement and the full nonrecurring charges for installation of the equivalent tariffed BellSouth service as set forth in BellSouth's tariffs.
- 5.2.2.6.7 For Subsequent Embedded Base circuits converted pursuant to Section 5.2.2.6.5 above or transitioned pursuant to Section 5.2.2.6.6.1 above, the applicable recurring tariff charges shall apply as of the earlier of the date each circuit is converted or transitioned, as applicable, or the first day after the end of the Subsequent Transition Period.
- 5.2.3 BellSouth shall:
- 5.2.4 Provide Smart City Communications exclusive use of Dedicated Transport to a particular customer or carrier;

- 5.2.5 Provide all technically feasible features, functions, and capabilities of Dedicated Transport as outlined within the technical requirements of this section;
- 5.2.6 Permit, to the extent technically feasible, Smart City Communications to connect Dedicated Transport to equipment designated by Smart City Communications, including but not limited to, Smart City Communications's collocated facilities; and
- 5.2.7 Permit, to the extent technically feasible, Smart City Communications to obtain the functionality provided by BellSouth's digital cross-connect systems.
- 5.3 BellSouth shall offer Dedicated Transport:
  - 5.3.1 As capacity on a shared facility; and
  - 5.3.2 As a circuit (i.e., DS0, DS1, DS3, STS-1) dedicated to Smart City Communications.
- 5.4 Dedicated Transport may be provided over facilities such as optical fiber, copper twisted pair, and coaxial cable, and shall include transmission equipment such as line terminating equipment, amplifiers, and regenerators.
- 5.5 Smart City Communications may obtain a maximum of twelve (12) unbundled DS3 Dedicated Transport circuits on each Route where DS3 Dedicated Transport is available as a Network Element, and a maximum of ten (10) unbundled DS1 Dedicated Transport circuits on each Route where there is no 251(c)(3) unbundling obligation for DS3 Dedicated Transport, but for which impairment exists for DS1 Dedicated Transport. For purposes of this Section 5, a "Route" is defined in 47 C.F.R. § 51.319 (e) as a transmission path between one of an incumbent LEC's wire centers or switches and another of the incumbent LECs wire centers or switches. A route between two (2) points (e.g. wire center or switch "A" and wire center or switch "Z") may pass through one or more intermediate wire centers or switches (e.g. wire center or switch "X"). Transmission paths between the same end points (e.g. wire center or switch "A" and wire center or switch "Z") are the same "route", irrespective of whether they pass through the same intermediate wire centers or switches, if any.
- 5.6 Technical Requirements
  - 5.6.1 BellSouth shall offer DS0 equivalent interface transmission rates for DS0 or voice grade Dedicated Transport. For DS1 or DS3 circuits, Dedicated Transport shall at a minimum meet the performance, availability, jitter, and delay requirements specified for Customer Interface to Central Office (CI to CO) connections in the applicable industry standards.

- 5.6.2 BellSouth shall offer the following interface transmission rates for Dedicated Transport:
  - 5.6.2.1 DS0 Equivalent;
  - 5.6.2.2 DS1;
  - 5.6.2.3 DS3;
  - 5.6.2.4 STS-1; and
  - 5.6.2.5 SDH (Synchronous Digital Hierarchy) Standard interface rates are in accordance with International Telecommunications Union (ITU) Recommendation G.707 and Plesiochronous Digital Hierarchy (PDH) rates per ITU Recommendation G.704.
- 5.6.3 BellSouth shall design Dedicated Transport according to its network infrastructure. Smart City Communications shall specify the termination points for Dedicated Transport.
- 5.6.4 At a minimum, Dedicated Transport shall meet each of the requirements set forth in the applicable industry technical references and BellSouth Technical References;
  - 5.6.4.1 Telcordia TR-TSY-000191 Alarm Indication Signals Requirements and Objectives, Issue 1, May 1986.
  - 5.6.4.2 BellSouth's TR73501 LightGate®Service Interface and Performance Specifications, Issue D, June 1995.
  - 5.6.4.3 BellSouth's TR73525 MegaLink®Service, MegaLink Channel Service and MegaLink Plus Service Interface and Performance Specifications, Issue C, May 1996.
- 5.7 Unbundled Channelization (Multiplexing)
  - 5.7.1 To the extent Smart City Communications is purchasing DS1 or DS3 or STS-1 Dedicated Transport pursuant to this Agreement, Unbundled Channelization (UC) provides the optional multiplexing capability that will allow a DS1 (1.544 Mbps) or DS3 (44.736 Mbps) or STS-1 (51.84 Mbps) Network Elements to be multiplexed or channelized at a BellSouth central office. Channelization can be accomplished through the use of a multiplexer or a digital cross-connect system at the discretion of BellSouth. Once UC has been installed, Smart City Communications may request channel activation on a channelized facility and BellSouth shall connect the requested facilities via COCIs. The COCI must be compatible with the lower capacity facility and ordered with the lower capacity facility. This service is available as defined in NECA 4.

- 5.7.2 BellSouth shall make available the following channelization systems and interfaces:
  - 5.7.2.1 DS1 Channelization System: channelizes a DS1 signal into a maximum of twenty-four (24) DS0s. The following COCI are available: Voice Grade, Digital Data and ISDN.
  - 5.7.2.2 DS3 Channelization System: channelizes a DS3 signal into a maximum of twenty-eight (28) DS1s. A DS1 COCI is available with this system.
  - 5.7.2.3 STS-1 Channelization System: channelizes a STS-1 signal into a maximum of twenty-eight (28) DS1s. A DS1 COCI is available with this system.
- 5.7.3 Technical Requirements. In order to assure proper operation with BellSouth provided central office multiplexing functionality, Smart City Communications's channelization equipment must adhere strictly to form and protocol standards. Smart City Communications must also adhere to such applicable industry standards for the multiplex channel bank, for voice frequency encoding, for various signaling schemes, and for sub rate digital access.
- 5.8 Dark Fiber Transport. Dark Fiber Transport is defined as Dedicated Transport that consists of unactivated optical interoffice transmission facilities without attached signal regeneration, multiplexing, aggregation or other electronics.
  - 5.8.1 Dark Fiber Transport Requirements
    - 5.8.1.1 For purposes of this Section 5.8, a Business Line is as defined in 47 C.F.R. § 51.5.
    - 5.8.1.2 Notwithstanding anything to the contrary in this Agreement, BellSouth shall make available Dark Fiber Transport as described in this Agreement, except in any wire center meeting the criteria described below:
      - 5.8.1.2.1 Dark Fiber Transport where both wire centers at the end points of the route contain twenty-four thousand (24,000) or more Business Lines or three (3) or more fiber-based collocators.
    - 5.8.1.3 The Master List of Unimpaired Wire Centers or BellSouth's List of Unimpaired Wire Centers, as described in Section 1.8, sets forth the list of wire centers meeting the criteria set forth in Section 5.8.1.2.1 above as of March 11, 2005.
    - 5.8.1.4 Once any wire center exceeds either of the thresholds set forth in Section 5.8.1.2.1 above, no future Dark Fiber Transport unbundling will be required in that wire center.

- 5.8.1.5 Modifications and Updates to the Wire Center List and Subsequent Transition Periods
- 5.8.1.5.1 In the event BellSouth identifies additional wire centers that meet the criteria set forth in Section 5.8.1.2.1 above, but that were not included in the Master List of Unimpaired Wire Centers or BellSouth's List of Unimpaired Wire Centers, BellSouth shall include such additional wire centers in a CNL. Each such list of additional wire centers shall be considered a "Subsequent Wire Center List". BellSouth will follow any notification procedures in applicable Commission orders.
- 5.8.1.5.2 Smart City Communications shall have thirty (30) business days to dispute the additional wire centers listed on BellSouth's CNL. Absent such dispute, effective thirty (30) business days after the date of a BellSouth CNL providing a Subsequent Wire Center List, BellSouth shall not be required to provide unbundled access to Dark Fiber Transport, as applicable, in such additional wire center(s), except pursuant to the self-certification process as set forth in Section 1.8 of this Attachment.
- 5.8.1.5.3 For purposes of Section 5.8.1.5 above, BellSouth shall make available Dark Fiber Transport that was in service for Smart City Communications in a wire center on the Subsequent Wire Center List as of the thirtieth (30) business day after the date of BellSouth's CNL identifying the Subsequent Wire Center List (Subsequent Embedded Base) until one hundred eighty (180) days after the thirtieth (30<sup>th</sup>) business day from the date of BellSouth's CNL identifying the Subsequent Wire Center List (Subsequent Transition Period).
- 5.8.1.5.4 The rates set forth in Exhibit B shall apply to the Subsequent Embedded Base during the Subsequent Transition Period.
- 5.8.1.5.5 No later than one hundred eighty (180) days from BellSouth's CNL identifying the Subsequent Wire Center List, Smart City Communications shall submit an LSR(s) or spreadsheet(s) as applicable, identifying the Subsequent Embedded Base of circuits to be disconnected or converted to other BellSouth services.
- 5.8.1.5.6 In the case of disconnection, the applicable disconnect charges set forth in this Agreement shall apply.
- 5.8.1.5.6.1 If Smart City Communications fails to submit the LSR(s) or spreadsheet(s) for all of its Subsequent Embedded Base by one hundred eighty (180) days after the date of BellSouth's CNL identifying the Subsequent Wire Center List, BellSouth will identify Smart City Communications's remaining Subsequent Embedded Base, if any, and will transition such circuits to the equivalent tariffed BellSouth service(s).
- 5.8.1.5.6.2 In the state of Florida, those circuits identified and transitioned by BellSouth shall be subject to the applicable disconnect charges as set forth in this Agreement and

the full nonrecurring charges for installation of the equivalent tariffed BellSouth service as set forth in BellSouth's tariffs.

- 5.8.1.5.6.3 For Subsequent Embedded Base circuits converted pursuant to Section 5.8.1.5.5 above or transitioned pursuant to Section 5.8.1.5.6.1 above, the applicable recurring tariff charges shall apply as of the earlier of the date each circuit is converted or transitioned, as applicable, or the first day after the end of the Subsequent Transition Period.

## 5.9 Rearrangements

- 5.9.1 A request to move a working Smart City Communications Dedicated Transport circuit or a Combination including Dedicated Transport from one connecting facility assignment (CFA) to another CFA in the same BellSouth Central Office (Change in CFA), shall not constitute the establishment of new service. The applicable Rearrangement rates for the Change in CFA are set forth in Exhibit A.

- 5.9.2 A request to reterminate one end of a Dedicated Transport facility that is not a Change in CFA and thus results in retermination in a different BellSouth Central Office (Retermination) shall constitute disconnection of existing service and the establishment of new service. Disconnect charges and full nonrecurring charges for establishment of service, as set forth in Exhibit A, shall apply.

- 5.9.3 Upon request of Smart City Communications, BellSouth shall project manage the Change in CFA or Retermination of Dedicated Transport and Combinations that include Dedicated Transport as described in Sections 5.9.1 and 5.9.2 above and Smart City Communications may request OC-TS for such orders.

- 5.9.4 BellSouth shall accept a LOA between Smart City Communications and another carrier that will allow Smart City Communications, in connection with a Change in CFA or Retermination, to connect Dedicated Transport or a Combination that includes Dedicated Transport, via a CFA, to the other carrier's collocation space or to another carrier's Multiplexer.

## 6 **Automatic Location Identification/Data Management System (ALI/DMS)**

### 6.1 911 and E911 Databases

- 6.1.1 BellSouth shall provide Smart City Communications with nondiscriminatory access to 911 and E911 databases on an unbundled basis, in accordance with 47 C.F.R. § 51.319 (f).

- 6.1.2 The ALI/DMS database contains end user information (including name, address, telephone information, and sometimes special information from the local service provider or end user) used to determine to which PSAP to route the call. The

ALI/DMS database is used to provide enhanced routing flexibility for E911. Smart City Communications will be required to provide the BellSouth 911 database vendor daily service order updates to E911 database in accordance with Section 6.2.1 below.

6.2 Technical Requirements

- 6.2.1 BellSouth's 911 database vendor shall provide Smart City Communications the capability of providing updates to the ALI/DMS database through a specified electronic interface. Smart City Communications shall contact BellSouth's 911 database vendor directly to request interface. Smart City Communications shall provide updates directly to BellSouth's 911 database vendor on a daily basis. Updates shall be the responsibility of Smart City Communications and BellSouth shall not be liable for the transactions between Smart City Communications and BellSouth's 911 database vendor.
- 6.2.2 It is Smart City Communications's responsibility to retrieve and confirm statistical data and to correct errors obtained from BellSouth's 911 database vendor on a daily basis. All errors will be assigned a unique error code and the description of the error and the corrective action is described in the CLEC Users Guide for Facility Based Providers that is found on the BellSouth Interconnection Web site.
- 6.2.3 Smart City Communications shall conform to the BellSouth standards as described in the CLEC Users Guide to E911 for Facilities Based Providers that is located on the BellSouth Interconnection Web site.
- 6.2.4 Stranded Unlocks are defined as end user records in BellSouth's ALI/DMS database that have not been migrated for over ninety (90) days to Smart City Communications, as a new provider of local service to the end user. Stranded Unlocks are those end user records that have been "unlocked" by the previous local exchange carrier that provided service to the end user and are open for Smart City Communications to assume responsibility for such records.
- 6.2.4.1 Based upon end user record ownership information available in the NPAC database, BellSouth shall provide a Stranded Unlock annual report to Smart City Communications that reflects all Stranded Unlocks that remain in the ALI/DMS database for over ninety (90) days. Smart City Communications shall review the Stranded Unlock report, identify its end user records and request to either delete such records or migrate the records to Smart City Communications within two (2) months following the date of the Stranded Unlock report provided by BellSouth. Smart City Communications shall reimburse BellSouth for any charges BellSouth's database vendor imposes on BellSouth for the deletion of Smart City Communications's records.



- 6.3 911 PBX Locate Service®. 911 PBX Locate Service is comprised of a database capability and a separate transport component.
- 6.3.1 Description of Product. The transport component provides a dedicated trunk path from a Private Branch Exchange (PBX) switch to the appropriate BellSouth 911 tandem.
- 6.3.1.1 The database capability allows Smart City Communications to offer an E911 service to its PBX end users that identifies to the PSAP the physical location of the Smart City Communications PBX 911 end user station telephone number for the 911 call that is placed by the end user.
- 6.3.2 Smart City Communications may order either the database capability or the transport component as desired or Smart City Communications may order both components of the service.
- 6.3.3 911 PBX Locate Database Capability. Smart City Communications's end user or Smart City Communications's end user's database management agent (DMA) must provide the end user PBX station telephone numbers and corresponding address and location data to BellSouth's 911 database vendor. The data will be loaded and maintained in BellSouth's ALI database.
- 6.3.4 Ordering, provisioning, testing and maintenance shall be provided by Smart City Communications pursuant to the 911 PBX Locate Marketing Service Description (MSD) that is located on the BellSouth Interconnection Web site.
- 6.3.5 Smart City Communications's end user, or Smart City Communications's end user DMA must provide ongoing updates to BellSouth's 911 database vendor within a commercially reasonable timeframe of all PBX station telephone number adds, moves and deletions. It will be the responsibility of Smart City Communications to ensure that the end user or DMA maintain the data pertaining to each end user's extension managed by the 911 PBX Locate Service product. Smart City Communications should not submit telephone number updates for specific PBX station telephone numbers that are submitted by Smart City Communications's end user, or Smart City Communications's end user DMA under the terms of 911 PBX Locate product.
- 6.3.5.1 Smart City Communications must provision all PBX station numbers in the same LATA as the E911 tandem.
- 6.3.6 Smart City Communications agrees to release, indemnify, defend and hold harmless BellSouth from any and all loss, claims, demands, suits, or other action, or any liability whatsoever, whether suffered, made, instituted or asserted by Smart City Communications's end user or by any other party or person, for any personal injury to or death of any person or persons, or for any loss, damage or destruction

of any property, whether owned by Smart City Communications or others, or for any infringement or invasion of the right of privacy of any person or persons, caused or claimed to have been caused, directly or indirectly, by the installation, operation, failure to operate, maintenance, removal, presence, condition, location or use of PBX Locate Service features or by any services which are or may be furnished by BellSouth in connection therewith, including but not limited to the identification of the telephone number, address or name associated with the telephone used by the party or parties accessing 911 services using 911 PBX Locate Service hereunder, except to the extent caused by BellSouth's gross negligence or wilful misconduct. Smart City Communications is responsible for assuring that its authorized end users comply with the provisions of these terms and that unauthorized persons do not gain access to or use the 911 PBX Locate Service through user names, passwords, or other identifiers assigned to Smart City Communications's end user or DMA pursuant to these terms. Specifically, Smart City Communications's end user or DMA must keep and protect from use by any unauthorized individual identifiers, passwords, and any other security token(s) and devices that are provided for access to this product.

- 6.3.7 Smart City Communications may only use BellSouth PBX Locate Service solely for the purpose of validating and correcting 911 related data for Smart City Communications's end users' telephone numbers for which it has direct management authority.
- 6.3.8 911 PBX Locate Transport Component. The 911 PBX Locate Service transport component requires Smart City Communications to order a CAMA type dedicated trunk from Smart City Communications's end user premise to the appropriate BellSouth 911 tandem pursuant to the following provisions.
  - 6.3.8.1 Except as otherwise set forth below, a minimum of two (2) end user specific, dedicated 911 trunks are required between the Smart City Communications's end user premise and the BellSouth 911 tandem as described in BellSouth's TR 73576 and in accordance with the 911 PBX Locate Marketing Service Description located on the BellSouth Interconnection Web site. Smart City Communications is responsible for connectivity between the end user's PBX and Smart City Communications's switch or POP location. Smart City Communications will then order 911 trunks from their switch or POP location to the BellSouth 911 tandem. The dedicated trunks shall be, at a minimum, DS0 level trunks configured as part of a digital interface (delivered over a Smart City Communications purchased DS1 facility that hands off at a DS1 or higher level digital or optical interface). Smart City Communications is responsible for ensuring that the PBX switch is capable of sending the calling station's Direct Inward Dial (DID) telephone number to the BellSouth 911 tandem in a specified Multi-frequency (MF) Address Signaling Protocol. If the PBX switch supports Primary Rate ISDN (PRI) and the calling

stations are DID numbers, then the 911 call can be transmitted using PRI, and there will be no requirement for the PBX Locate Transport component.

- 6.3.9 Ordering and Provisioning. Smart City Communications will submit an Access Service Request (ASR) to BellSouth to order a minimum of two (2) end user specific 911 trunks from its switch or POP location to the BellSouth 911 tandem.
- 6.3.9.1 Testing and maintenance shall be provided by Smart City Communications pursuant to the 911 PBX Locate Marketing Service description that is located on the BellSouth Interconnection Web site.
- 6.3.10 Rates. Rates for the 911 PBX Locate Service database component are set forth in Exhibit A. Trunks and facilities for 911 PBX Locate transport component may be ordered by Smart City Communications pursuant to the terms and conditions set forth in Attachment 3.

## **7 White Pages Listings**

- 7.1 BellSouth shall provide Smart City Communications and its customers access to white pages directory listings under the following terms:
  - 7.1.1 Listings. Smart City Communications shall provide all new, changed and deleted listings on a timely basis and BellSouth or its agent will include Smart City Communications residential and business customer listings in the appropriate White Pages (residential and business) or alphabetical directories in the geographic areas covered by this Agreement. Directory listings will make no distinction between Smart City Communications and BellSouth customers. Smart City Communications shall provide listing information in accordance with the procedures set forth in The BellSouth Business Rules for Local Ordering found at BellSouth's Interconnection Services Web site.
  - 7.1.2 Unlisted/Non-Published Customers. Smart City Communications will be required to provide to BellSouth the names, addresses and telephone numbers of all Smart City Communications customers who wish to be omitted from directories. Unlisted/Non-Published listings will be subject to the rates as set forth in BellSouth's GSST and shall not be subject to wholesale discount.
  - 7.1.3 Inclusion of Smart City Communications Customers in Directory Assistance Database. BellSouth will include and maintain Smart City Communications customer listings in BellSouth's DA databases. Smart City Communications shall provide such Directory Assistance listings to BellSouth at no charge.
  - 7.1.4 Listing Information Confidentiality. BellSouth will afford Smart City Communications's directory listing information the same level of confidentiality that BellSouth affords its own directory listing information.

- 7.1.5 Additional and Designer Listings. Additional and designer listings will be offered by BellSouth at tariffed rates as set forth in BellSouth's GSST and shall not be subject to the wholesale discount.
- 7.1.6 Rates. So long as Smart City Communications provides listing information to BellSouth as set forth in Section 7.1.2 above, BellSouth shall provide to Smart City Communications one (1) basic White Pages directory listing per Smart City Communications customer at no charge other than applicable service order charges as set forth in BellSouth's tariffs. Except in the case of a LSR submitted solely to port a number from BellSouth, if such listing is requested on the initial LSR associated with the request for services, a single manual service order charge or electronic service order charge, as appropriate, as described in Attachment 6, will apply to both the request for service and the request for the directory listing. Where a subsequent LSR is placed solely to request a directory listing, or is placed to port a number and request a directory listing, separate service order charges as set forth in BellSouth's tariffs shall apply, as well as the manual service order charge or the electronic service order charge, as appropriate, as described in Attachment 6.
- 7.2 Directories. BellSouth or its agent shall make available White Pages directories to Smart City Communications customer at no charge or as specified in a separate agreement between Smart City Communications and BellSouth's agent.
- 7.3 Procedures for submitting Smart City Communications Subscriber Listing Information (SLI) are found in The BellSouth Business Rules for Local Ordering found at BellSouth's Interconnection Services Web site.
- 7.3.1 Smart City Communications authorizes BellSouth to release all Smart City Communications SLI provided to BellSouth by Smart City Communications to qualifying third parties. Such Smart City Communications SLI shall be intermingled with BellSouth's own customer listings and listings of any other CLEC that has authorized a similar release of SLI.
- 7.3.2 No compensation shall be paid to Smart City Communications for BellSouth's receipt of Smart City Communications SLI, or for the subsequent release to third parties of such SLI. In addition, to the extent BellSouth incurs costs to modify its systems to enable the release of Smart City Communications's SLI, or costs on an ongoing basis to administer the release of Smart City Communications SLI, Smart City Communications shall pay to BellSouth its proportionate share of the reasonable costs associated therewith. At any time that costs may be incurred to administer the release of Smart City Communications's SLI, Smart City Communications will be notified. If Smart City Communications does not wish to pay its proportionate share of these reasonable costs, Smart City Communications may instruct BellSouth that it does not wish to release its SLI to independent publishers, and Smart City Communications shall amend this Agreement

accordingly. Smart City Communications will be liable for all costs incurred until the effective date of the agreement.

- 7.3.3 Neither BellSouth nor any agent shall be liable for the content or accuracy of any SLI provided by Smart City Communications under this Agreement. Smart City Communications shall indemnify, except to the extent caused by BellSouth's gross negligence or willful misconduct, hold harmless and defend BellSouth and its agents from and against any damages, losses, liabilities, demands, claims, suits, judgments, costs and expenses (including but not limited to reasonable attorneys' fees and expenses) arising from BellSouth's tariff obligations or otherwise and resulting from or arising out of any third party's claim of inaccurate Smart City Communications listings or use of the SLI provided pursuant to this Agreement. BellSouth may forward to Smart City Communications any complaints received by BellSouth relating to the accuracy or quality of Smart City Communications listings.
- 7.3.4 Listings and subsequent updates will be released consistent with BellSouth system changes and/or update scheduling requirements.

UNBUNDLED NETWORK ELEMENTS - Florida											Att: 2 Exh: A				
CATEGORY	RATE ELEMENTS	Interim	Zone	BCS	USOC	RATES(\$)				Svc Order Submitted Elec per LSR	Svc Order Submitted Manually per LSR	Incremental Charge - Manual Svc Order vs. Electronic-1st	Incremental Charge - Manual Svc Order vs. Electronic-Add'l	Incremental Charge - Manual Svc Order vs. Electronic-Disc 1st	Incremental Charge - Manual Svc Order vs. Electronic-Disc Add'l
						Rec	Nonrecurring		Nonrecurring Disconnect						
						First	Add'l	First	Add'l	SOMEc	SOMAN	SOMAN	SOMAN	SOMAN	SOMAN
The "Zone" shown in the sections for stand-alone loops or loops as part of a combination refers to Geographically Deaveraged UNE Zones. To view Geographically Deaveraged UNE Zone Designations by Central Office, refer to internet Website: <a href="http://www.interconnection.bellsouth.com/become_a_clec/html/interconnection.htm">http://www.interconnection.bellsouth.com/become_a_clec/html/interconnection.htm</a>															
OPERATIONS SUPPORT SYSTEMS (OSS) - "REGIONAL RATES"															
NOTE: (1) CLEC should contact its contract negotiator if it prefers the "state specific" OSS charges as ordered by the State Commissions. The OSS charges currently contained in this rate exhibit are the BellSouth "regional" service ordering charges. CLEC may elect either the state specific Commission ordered rates for the service ordering charges, or CLEC may elect the regional service ordering charge, however, CLEC can not obtain a mixture of the two regardless if CLEC has an interconnection contract established in each of the 9 states.															
NOTE: (2) Any element that can be ordered electronically will be billed according to the SOMEc rate listed in this category. Please refer to BellSouth's Local Ordering Handbook (LOH) to determine if a product can be ordered electronically. For those elements that cannot be ordered electronically at present per the LOH, the listed SOMEc rate in this category reflects the charge that would be billed to a CLEC once electronic ordering capabilities come on-line for that element. Otherwise, the manual ordering charge, SOMAN, will be applied to a CLECs bill when it submits an LSR to BellSouth.															
	OSS - Electronic Service Order Charge, Per Local Service Request (LSR) - UNE Only				SOMEc	3.50	0.00	3.50	0.00						
	OSS - Manual Service Order Charge, Per Local Service Request (LSR) - UNE Only				SOMAN	11.90	0.00	1.83	0.00						
<b>UNE SERVICE DATE ADVANCEMENT CHARGE</b>															
NOTE: The Expedite charge will be maintained commensurate with BellSouth's FCC No.1 Tariff, Section 5 as applicable.															
	UNE Expedite Charge per Circuit or Line Assignable USOC, per Day			UAL, UEANL, UCL, UEF, UDF, UEQ, UDL, UENTW, UDN, UEA, UHL, ULC, USL, U1T12, U1T48, U1TD1, U1TD3, U1TDX, U1TO3, U1TS1, U1TVX, UC1BC, UC1BL, UC1CC, UC1CL, UC1DC, UC1DL, UC1EC, UC1EL, UC1FC, UC1FL, UC1GC, UC1GL, UC1HC, UC1HL, UDL12, UDL48, UDL03, UDL5X, UE3, ULD12, ULD48, ULDD1, ULDD3, ULDDX, ULDO3, ULDS1, ULDVX, UNC1X, UNC3X, UNCDX, UCNX, UNCSX, UNCVX, UNLD1, UNLD3, UXTD1, UXTD3, UXTS1, U1TUC, U1TUD, U1TUB, U1TUA, NTCVG, NTCUD, NTCD1	SDASP	200.00									
<b>ORDER MODIFICATION CHARGE</b>															
	Order Modification Charge (OMC)					26.21	0.00	0.00	0.00						
	Order Modification Additional Dispatch Charge (OMCAD)					150.00	0.00	0.00	0.00						
<b>UNBUNDLED EXCHANGE ACCESS LOOP</b>															
<b>2-WIRE ANALOG VOICE GRADE LOOP</b>															
	2-Wire Analog Voice Grade Loop - Service Level 1- Zone 1		1	UEANL	UEAL2	10.69	49.57	22.83	25.62	6.57					
	2-Wire Analog Voice Grade Loop - Service Level 1- Zone 2		2	UEANL	UEAL2	15.20	49.57	22.83	25.62	6.57					
	2-Wire Analog Voice Grade Loop - Service Level 1- Zone 3		3	UEANL	UEAL2	26.97	49.57	22.83	25.62	6.57					
	2-Wire Analog Voice Grade Loop - Service Level 1- Zone 1		1	UEANL	UEASL	10.69	49.57	22.83	25.62	6.57					
	2-Wire Analog Voice Grade Loop - Service Level 1- Zone 2		2	UEANL	UEASL	15.20	49.57	22.83	25.62	6.57					
	2-Wire Analog Voice Grade Loop - Service Level 1- Zone 3		3	UEANL	UEASL	26.97	49.57	22.83	25.62	6.57					
	Tag Loop at End User Premise			UEANL	URETL		8.93	0.88							
	Loop Testing - Basic 1st Half Hour			UEANL	URET1		77.09	0.00							
	Loop Testing - Basic Additional Half Hour			UEANL	URETA		33.12	33.12							
	Manual Order Coordination for UVL-SL1s (per loop)			UEANL	UEAMC		9.00	9.00							
	Order Coordination for Specified Conversion Time for UVL-SL1 (per LSR)			UEANL	OCOSL		23.02								

UNBUNDLED NETWORK ELEMENTS - Florida											Att: 2 Exh: A											
CATEGORY	RATE ELEMENTS	Interim	Zone	BCS	USOC	RATES(\$)	Svc Order Submitted Elec per LSR	Svc Order Submitted Manually per LSR	Incremental Charge - Manual Svc Order vs. Electronic-1st	Incremental Charge - Manual Svc Order vs. Electronic-Add'l	Incremental Charge - Manual Svc Order vs. Electronic-Disc 1st	Incremental Charge - Manual Svc Order vs. Electronic-Disc Add'l	OSS Rates(\$)									
													Rec	Nonrecurring		Nonrecurring Disconnect		SOMECE	SOMAN	SOMAN	SOMAN	SOMAN
														First	Add'l	First	Add'l					
	Unbundled Non-Design Voice Loop, billing for BST providing make up (Engineering Information - E.I.)			UEANL	UEANM	13.49																
	Unbundled Loop Service Rearrangement, change in loop facility, per circuit			UEANL	UREWO	15.78	8.94	25.62	6.57													
	Bulk Migration, per 2 Wire Voice Loop-SL1			UEANL	UREPN	49.57	22.83	25.62	6.57													
	Bulk Migration Order Coordination, per 2 Wire Voice Loop-SL1			UEANL	UREPM	9.00	9.00															
	<b>2-WIRE UNBUNDLED COPPER LOOP</b>																					
	2-Wire Unbundled Copper Loop - Non-Designed Zone 1		1	UEQ	UEQ2X	7.69	44.98	20.90	24.88	6.45												
	2 Wire Unbundled Copper Loop - Non-Designed - Zone 2		2	UEQ	UEQ2X	10.92	44.98	20.90	24.88	6.45												
	2 Wire Unbundled Copper Loop - Non-Designed - Zone 3		3	UEQ	UEQ2X	19.38	44.98	20.90	24.88	6.45												
	Tag Loop at End User Premise			UEQ	URETL	8.93	0.88															
	Loop Testing - Basic 1st Half Hour			UEQ	URET1	48.65	0.00															
	Loop Testing - Basic Additional Half Hour			UEQ	URETA	23.95	23.95															
	Manual Order Coordination 2 Wire Unbundled Copper Loop - Non-Designed (per loop)			UEQ	USBMC	9.00	9.00															
	Unbundled Copper Loop - Non-Design, billing for BST providing make-up (Engineering Information - E.I.)			UEQ	UEQMU	13.49																
	Unbundled Loop Service Rearrangement, change in loop facility, per circuit			UEQ	UREWO	14.27	7.43	24.88	6.45													
	Bulk Migration, per 2 Wire UCL-ND			UEQ	UREPN	44.98	20.90	24.88	6.45													
	Bulk Migration Order Coordination, per 2 Wire UCL-ND			UEQ	UREPM	9.00	9.00															
	<b>UNBUNDLED EXCHANGE ACCESS LOOP</b>																					
	<b>2-WIRE ANALOG VOICE GRADE LOOP</b>																					
	2-Wire Analog Voice Grade Loop - Service Level 2 w/Loop or Ground Start Signaling - Zone 1		1	UEA	UEAL2	12.24	135.75	82.47	63.53	12.01												
	2-Wire Analog Voice Grade Loop - Service Level 2 w/Loop or Ground Start Signaling - Zone 2		2	UEA	UEAL2	17.40	135.75	82.47	63.53	12.01												
	2-Wire Analog Voice Grade Loop - Service Level 2 w/Loop or Ground Start Signaling - Zone 3		3	UEA	UEAL2	30.87	135.75	82.47	63.53	12.01												
	2-Wire Analog Voice Grade Loop - Service Level 2 w/Reverse Battery Signaling - Zone 1		1	UEA	UEAR2	12.24	135.75	82.47	63.53	12.01												
	2-Wire Analog Voice Grade Loop - Service Level 2 w/Reverse Battery Signaling - Zone 2		2	UEA	UEAR2	17.40	135.75	82.47	63.53	12.01												
	2-Wire Analog Voice Grade Loop - Service Level 2 w/Reverse Battery Signaling - Zone 3		3	UEA	UEAR2	30.87	135.75	82.47	63.53	12.01												
	Switch-As-Is Conversion rate per UNE Loop, Single LSR, (per DS0)			UEA	URES1		8.98	8.98														
	Switch-As-Is Conversion rate per UNE Loop, Spreadsheet, (per DS0)			UEA	URES2		8.98	8.98														
	Unbundled Loop Service Rearrangement, change in loop facility, per circuit			UEA	UREWO	87.71	36.35															
	Loop Tagging - Service Level 2 (SL2)			UEA	URETL	11.21	1.10															
	Bulk Migration, per 2 Wire Voice Loop-SL2			UEA	UREPN	135.75	82.47															
	Bulk Migration Order Coordination, per 2 Wire Voice Loop-SL2			UEA	UREPM	0.00	0.00															
	<b>4-WIRE ANALOG VOICE GRADE LOOP</b>																					
	4-Wire Analog Voice Grade Loop - Zone 1		1	UEA	UEAL4	18.89	167.86	115.15	67.08	15.56												
	4-Wire Analog Voice Grade Loop - Zone 2		2	UEA	UEAL4	26.84	167.86	115.15	67.08	15.56												
	4-Wire Analog Voice Grade Loop - Zone 3		3	UEA	UEAL4	47.62	167.86	115.15	67.08	15.56												
	Switch-As-Is Conversion rate per UNE Loop, Single LSR, (per DS0)			UEA	URES1		8.98	8.98														
	Switch-As-Is Conversion rate per UNE Loop, Spreadsheet, (per DS0)			UEA	URES2		8.98	8.98														
	Unbundled Loop Service Rearrangement, change in loop facility, per circuit			UEA	UREWO	87.71	36.35															
	<b>2-WIRE ISDN DIGITAL GRADE LOOP</b>																					
	2-Wire ISDN Digital Grade Loop - Zone 1		1	UDN	U1L2X	19.28	147.69	94.41	62.23	10.71												
	2-Wire ISDN Digital Grade Loop - Zone 2		2	UDN	U1L2X	27.40	147.69	94.41	62.23	10.71												
	2-Wire ISDN Digital Grade Loop - Zone 3		3	UDN	U1L2X	48.62	147.69	94.41	62.23	10.71												
	Unbundled Loop Service Rearrangement, change in loop facility, per circuit			UDN	UREWO	91.61	44.15															
	<b>2-WIRE ASYMMETRICAL DIGITAL SUBSCRIBER LINE (ADSL) COMPATIBLE LOOP</b>																					
	2 Wire Unbundled ADSL Loop including manual service inquiry & facility reservation - Zone 1		1	UAL	UAL2X	8.30	149.53	103.85	75.05	15.63												





UNBUNDLED NETWORK ELEMENTS - Florida											Att: 2 Exh: A											
CATEGORY	RATE ELEMENTS	Interim	Zone	BCS	USOC	RATES(\$)	Svc Order Submitted Elec per LSR	Svc Order Submitted Manually per LSR	Incremental Charge - Manual Svc Order vs. Electronic-1st	Incremental Charge - Manual Svc Order vs. Electronic-Add'l	Incremental Charge - Manual Svc Order vs. Electronic-Disc 1st	Incremental Charge - Manual Svc Order vs. Electronic-Disc Add'l	OSS Rates(\$)									
													Rec	Nonrecurring		Nonrecurring Disconnect		SOMEK	SOMAN	SOMAN	SOMAN	SOMAN
														First	Add'l	First	Add'l					
	4 Wire Unbundled Digital 19.2 Kbps - Zone 3		3	UDL	UDL19	55.99	161.56	108.85	67.08	15.56												
	4 Wire Unbundled Digital Loop 56 Kbps - Zone 1		1	UDL	UDL56	22.20	161.56	108.85	67.08	15.56												
	4 Wire Unbundled Digital Loop 56 Kbps - Zone 2		2	UDL	UDL56	31.56	161.56	108.85	67.08	15.56												
	4 Wire Unbundled Digital Loop 56 Kbps - Zone 3		3	UDL	UDL56	55.99	161.56	108.85	67.08	15.56												
	4 Wire Unbundled Digital Loop 64 Kbps - Zone 1		1	UDL	UDL64	22.20	161.56	108.85	67.08	15.56												
	4 Wire Unbundled Digital Loop 64 Kbps - Zone 2		2	UDL	UDL64	31.56	161.56	108.85	67.08	15.56												
	4 Wire Unbundled Digital Loop 64 Kbps - Zone 3		3	UDL	UDL64	55.99	161.56	108.85	67.08	15.56												
	Switch-As-Is Conversion rate per UNE Loop, Single LSR, (per DSO)			UDL	URESL		8.98	8.98														
	Switch-As-Is Conversion rate per UNE Loop, Spreadsheet, (per DSO)			UDL	URESP		8.98	8.98														
	Unbundled Loop Service Rearrangement, change in loop facility, per circuit			UDL	UREWO		102.11	49.74														
<b>2-WIRE Unbundled COPPER LOOP</b>																						
	2-Wire Unbundled Copper Loop-Designed including manual service inquiry & facility reservation - Zone 1		1	UCL	UCLPB	8.30	148.50	102.82	75.05	15.63												
	2-Wire Unbundled Copper Loop-Designed including manual service inquiry & facility reservation - Zone 2		2	UCL	UCLPB	11.80	148.50	102.82	75.05	15.63												
	2 Wire Unbundled Copper Loop-Designed including manual service inquiry & facility reservation - Zone 3		3	UCL	UCLPB	20.94	148.50	102.82	75.05	15.63												
	2-Wire Unbundled Copper Loop-Designed without manual service inquiry and facility reservation - Zone 1		1	UCL	UCLPW	8.30	123.81	70.09	60.64	9.12												
	2-Wire Unbundled Copper Loop-Designed without manual service inquiry and facility reservation - Zone 2		2	UCL	UCLPW	11.80	123.81	70.09	60.64	9.12												
	2-Wire Unbundled Copper Loop-Designed without manual service inquiry and facility reservation - Zone 3		3	UCL	UCLPW	20.94	123.81	70.09	60.64	9.12												
	CLEC to CLEC Conversion Charge without outside dispatch (UCL-Des)			UCL	UREWO		97.21	42.47														
	Unbundled Loop Service Rearrangement, change in loop facility, per circuit			UCL	UCLMC		9.00	9.00														
<b>4-WIRE COPPER LOOP</b>																						
	4-Wire Copper Loop-Designed including manual service inquiry and facility reservation - Zone 1		1	UCL	UCL4S	11.83	177.87	132.76	77.15	17.73												
	4-Wire Copper Loop-Designed including manual service inquiry and facility reservation - Zone 2		2	UCL	UCL4S	16.81	177.87	132.76	77.15	17.73												
	4-Wire Copper Loop-Designed including manual service inquiry and facility reservation - Zone 3		3	UCL	UCL4S	29.82	177.87	132.76	77.15	17.73												
	4-Wire Copper Loop-Designed without manual service inquiry and facility reservation - Zone 1		1	UCL	UCL4W	11.83	153.18	100.03	62.74	11.22												
	4-Wire Copper Loop-Designed without manual service inquiry and facility reservation - Zone 2		2	UCL	UCL4W	16.81	153.18	100.03	62.74	11.22												
	4-Wire Copper Loop-Designed without manual service inquiry and facility reservation - Zone 3		3	UCL	UCL4W	29.82	153.18	100.03	62.74	11.22												
	Order Coordination for Unbundled Copper Loops (per loop)			UCL	UCLMC		9.00	9.00														
	Unbundled Loop Service Rearrangement, change in loop facility, per circuit			UCL	UREWO		97.21	42.47														
	Order Coordination for Specified Conversion Time (per LSR)			UEA, UDN, UAL, UHL, UDL, USL	OCOSL		23.02															
<b>Rearrangements</b>																						
	EEL to UNE-L Retermination, per 2 Wire Unbundled Voice Loop-SL2			UEA	UREEL		87.71	36.35														
	EEL to UNE-L Retermination, per 4 Wire Unbundled Voice Loop			UEA	UREEL		87.71	36.35														
	EEL to UNE-L Retermination, per 2 Wire ISDN Loop			UDN	UREEL		91.61	44.15														
	EEL to UNE-L Retermination, per 4 Wire Unbundled Digital Loop			UDL	UREEL		102.11	49.74														
	EEL to UNE-L Retermination, per 4 Wire Unbundled DS1 Loop			USL	UREEL		101.07	43.04														
<b>UNE LOOP COMMINGLING</b>																						
<b>2-WIRE ANALOG VOICE GRADE LOOP - COMMINGLING</b>																						
	2-Wire Analog Voice Grade Loop - Service Level 2 w/Loop or Ground Start Signaling - Zone 1		1	NTCVG	UEAL2	12.24	135.75	82.47	63.53	12.01												
	2-Wire Analog Voice Grade Loop - Service Level 2 w/Loop or Ground Start Signaling - Zone 2		2	NTCVG	UEAL2	17.40	135.75	82.47	63.53	12.01												

UNBUNDLED NETWORK ELEMENTS - Florida

CATEGORY	RATE ELEMENTS	Interim	Zone	BCS	USOC	RATES(\$)					Svc Order Submitted Elec per LSR	Svc Order Submitted Manually per LSR	Incremental Charge - Manual Svc Order vs. Electronic-1st					
						Rec	Nonrecurring		Nonrecurring Disconnect				OSS Rates(\$)					
							First	Add'l	First	Add'l			SOMECE	SOMAN	SOMAN	SOMAN	SOMAN	
	2-Wire Analog Voice Grade Loop - Service Level 2 w/Loop or Ground Start Signaling - Zone 3		3	NTCVG	UEAL2	30.87	135.75	82.47	63.53	12.01								
	2-Wire Analog Voice Grade Loop - Service Level 2 w/Reverse Battery Signaling - Zone 1		1	NTCVG	UEAR2	12.24	135.75	82.47	63.53	12.01								
	2-Wire Analog Voice Grade Loop - Service Level 2 w/Reverse Battery Signaling - Zone 2		2	NTCVG	UEAR2	17.40	135.75	82.47	63.53	12.01								
	2-Wire Analog Voice Grade Loop - Service Level 2 w/Reverse Battery Signaling - Zone 3		3	NTCVG	UEAR2	30.87	135.75	82.47	63.53	12.01								
	Switch-As-Is Conversion rate per UNE Loop, Single LSR, (per DS0)			NTCVG	URESL		8.98	8.98										
	Switch-As-Is Conversion rate per UNE Loop, Spreadsheet, (per DS0)			NTCVG	URESP		8.98	8.98										
	Unbundled Loop Service Rearrangement, change in loop facility, per circuit			NTCVG	UREWO		87.71	36.35										
	Loop Tagging - Service Level 2 (SL2)			NTCVG	URETL		11.21	1.10										
<b>4-WIRE ANALOG VOICE GRADE LOOP - COMMINGLING</b>																		
	4-Wire Analog Voice Grade Loop - Zone 1		1	NTCVG	UEAL4	18.89	167.86	115.15	67.08	15.56								
	4-Wire Analog Voice Grade Loop - Zone 2		2	NTCVG	UEAL4	26.84	167.86	115.15	67.08	15.56								
	4-Wire Analog Voice Grade Loop - Zone 3		3	NTCVG	UEAL4	47.62	167.86	115.15	67.08	15.56								
	Switch-As-Is Conversion rate per UNE Loop, Single LSR, (per DS0)			NTCVG	URESL		8.98	8.98										
	Switch-As-Is Conversion rate per UNE Loop, Spreadsheet, (per DS0)			NTCVG	URESP		8.98	8.98										
	Unbundled Loop Service Rearrangement, change in loop facility, per circuit			NTCVG	UREWO		87.71	36.35										
<b>4-WIRE DS1 DIGITAL LOOP - COMMINGLING</b>																		
	4-Wire DS1 Digital Loop - Zone 1		1	NTCD1	USLXX	70.74	313.75	181.48	61.22	13.53								
	4-Wire DS1 Digital Loop - Zone 2		2	NTCD1	USLXX	100.54	313.75	181.48	61.22	13.53								
	4-Wire DS1 Digital Loop - Zone 3		3	NTCD1	USLXX	178.39	313.75	181.48	61.22	13.53								
	Switch-As-Is Conversion rate per UNE Loop, Single LSR, (per DS1)			NTCD1	URESL		8.98	8.98										
	Switch-As-Is Conversion rate per UNE Loop, Spreadsheet, (per DS1)			NTCD1	URESP		8.98	8.98										
	Unbundled Loop Service Rearrangement, change in loop facility, per circuit			NTCD1	UREWO		101.07	43.04										
<b>4-WIRE 19.2, 56 OR 64 KBPS DIGITAL GRADE LOOP - COMMINGLING</b>																		
	3 Wire Unbundled Digital Loop 2.4 Kbps - Zone 1		1	NTCUD	UDL2X	22.20	161.56	108.85	67.08	15.56								
	4 Wire Unbundled Digital Loop 2.4 Kbps - Zone 2		2	NTCUD	UDL2X	31.56	161.56	108.85	67.08	15.56								
	4 Wire Unbundled Digital Loop 2.4 Kbps - Zone 3		3	NTCUD	UDL2X	55.99	161.56	108.85	67.08	15.56								
	4 Wire Unbundled Digital Loop 4.8 Kbps - Zone 1		1	NTCUD	UDL4X	22.20	161.56	108.85	67.08	15.56								
	4 Wire Unbundled Digital Loop 4.8 Kbps - Zone 2		2	NTCUD	UDL4X	31.56	161.56	108.85	67.08	15.56								
	4 Wire Unbundled Digital Loop 4.8 Kbps - Zone 3		3	NTCUD	UDL4X	55.99	161.56	108.85	67.08	15.56								
	4 Wire Unbundled Digital Loop 9.6 Kbps - Zone 1		1	NTCUD	UDL9X	22.20	161.56	108.85	67.08	15.56								
	4 Wire Unbundled Digital Loop 9.6 Kbps - Zone 2		2	NTCUD	UDL9X	31.56	161.56	108.85	67.08	15.56								
	4 Wire Unbundled Digital Loop 9.6 Kbps - Zone 3		3	NTCUD	UDL9X	55.99	161.56	108.85	67.08	15.56								
	4 Wire Unbundled Digital 19.2 Kbps - Zone 1		1	NTCUD	UDL19	22.20	161.56	108.85	67.08	15.56								
	4 Wire Unbundled Digital 19.2 Kbps - Zone 2		2	NTCUD	UDL19	31.56	161.56	108.85	67.08	15.56								
	4 Wire Unbundled Digital 19.2 Kbps - Zone 3		3	NTCUD	UDL19	55.99	161.56	108.85	67.08	15.56								
	4 Wire Unbundled Digital Loop 56 Kbps - Zone 1		1	NTCUD	UDL56	22.20	161.56	108.85	67.08	15.56								
	4 Wire Unbundled Digital Loop 56 Kbps - Zone 2		2	NTCUD	UDL56	31.56	161.56	108.85	67.08	15.56								
	4 Wire Unbundled Digital Loop 56 Kbps - Zone 3		3	NTCUD	UDL56	55.99	161.56	108.85	67.08	15.56								
	4 Wire Unbundled Digital Loop 64 Kbps - Zone 1		1	NTCUD	UDL64	22.20	161.56	108.85	67.08	15.56								
	4 Wire Unbundled Digital Loop 64 Kbps - Zone 2		2	NTCUD	UDL64	31.56	161.56	108.85	67.08	15.56								
	4 Wire Unbundled Digital Loop 64 Kbps - Zone 3		3	NTCUD	UDL64	55.99	161.56	108.85	67.08	15.56								
	Switch-As-Is Conversion rate per UNE Loop, Single LSR, (per DS0)			NTCUD	URESL		8.98	8.98										
	Switch-As-Is Conversion rate per UNE Loop, Spreadsheet, (per DS0)			NTCUD	URESP		8.98	8.98										
	Unbundled Loop Service Rearrangement, change in loop facility, per circuit			NTCUD	UREWO		102.11	49.74										
	Order Coordination for Specified Conversion Time (per LSR)			NTCVG, NTCUD, NTCD1	OCOSL		23.02											
<b>MAINTENANCE OF SERVICE</b>																		

UNBUNDLED NETWORK ELEMENTS - Florida											Att: 2 Exh: A				
CATEGORY	RATE ELEMENTS	Interim	Zone	BCS	USOC	RATES(\$)				Svc Order Submitted Elec per LSR	Svc Order Submitted Manually per LSR	Incremental Charge - Manual Svc Order vs. Electronic-1st	Incremental Charge - Manual Svc Order vs. Electronic-Add'l	Incremental Charge - Manual Svc Order vs. Electronic-Disc 1st	Incremental Charge - Manual Svc Order vs. Electronic-Disc Add'l
						Rec	Nonrecurring		Nonrecurring Disconnect						
							First	Add'l	First	Add'l	SOMECC	SOMAN	SOMAN	SOMAN	SOMAN
	Maintenance of Service Charge, Basic Time, per half hour			UDC, UEA, UDL, UDN, USL, UAL, UHL, UCL, NTCVCG, NTCUD, NTCDD1, U1TD1, U1TD3, U1TDX, U1TS1, U1TVX, UDF, UDFCX, UDLSX, UE3, ULDD1, ULDD3, ULDDX, ULDS1, ULDVX, UNC1X, UNC3X, UNCDX, UNCSX, UNCVX, ULS	MVVB		80.00	55.00							
	Maintenance of Service Charge, Overtime, per half hour			UDC, UEA, UDL, UDN, USL, UAL, UHL, UCL, NTCVCG, NTCUD, NTCDD1, U1TD1, U1TD3, U1TDX, U1TS1, U1TVX, UDF, UDFCX, UDLSX, UE3, ULDD1, ULDD3, ULDDX, ULDS1, ULDVX, UNC1X, UNC3X, UNCDX, UNCSX, UNCVX, ULS	MVVOT		90.00	65.00							
	Maintenance of Service Charge, Premium, per half hour			UDC, UEA, UDL, UDN, USL, UAL, UHL, UCL, NTCVCG, NTCUD, NTCDD1, U1TD1, U1TD3, U1TDX, U1TS1, U1TVX, UDF, UDFCX, UDLSX, UE3, ULDD1, ULDD3, ULDDX, ULDS1, ULDVX, UNC1X, UNC3X, UNCDX, UNCSX, UNCVX, ULS	MVVPT		100.00	75.00							
<b>LOOP MODIFICATION</b>															
	Unbundled Loop Modification, Removal of Load Coils - 2 Wire pair less than or equal to 18k ft, per Unbundled Loop			UAL, UHL, UCL, UEQ, ULS, UEA, UEANL, UEPSR, UEPSB	ULM2L		0.00	0.00							
	Unbundled Loop Modification Removal of Load Coils - 4 Wire less than or equal to 18K ft, per Unbundled Loop			UHL, UCL, UEA	ULM4L		0.00	0.00							
	Unbundled Loop Modification Removal of Bridged Tap Removal, per unbundled loop			UAL, UHL, UCL, UEQ, ULS, UEA, UEANL, UEPSR, UEPSB	ULMBT		10.52	10.52							
<b>SUB-LOOPS</b>															
<b>Sub-Loop Distribution</b>															
	Sub-Loop - Per Cross Box Location - CLEC Feeder Facility Set-Up			UEANL, UEF	USBSA		487.23								
	Sub-Loop - Per Cross Box Location - Per 25 Pair Panel Set-Up			UEANL, UEF	USBSB		6.25								
	Sub-Loop - Per Building Equipment Room - CLEC Feeder Facility Set-Up			UEANL	USBSC		169.25								
	Sub-Loop - Per Building Equipment Room - Per 25 Pair Panel Set-Up			UEANL	USBSD		38.65								

UNBUNDLED NETWORK ELEMENTS - Florida											Att: 2 Exh: A											
CATEGORY	RATE ELEMENTS	Interim	Zone	BCS	USOC	RATES(\$)					Svc Order Submitted Elec per LSR	Svc Order Submitted Manually per LSR	Incremental Charge - Manual Svc Order vs. Electronic-1st	Incremental Charge - Manual Svc Order vs. Electronic-Add'l	Incremental Charge - Manual Svc Order vs. Electronic-Disc 1st	Incremental Charge - Manual Svc Order vs. Electronic-Disc Add'l						
						Rec	Nonrecurring		Nonrecurring Disconnect								OSS Rates(\$)					
							First	Add'l	First	Add'l							SOMEc	SOMAN	SOMAN	SOMAN	SOMAN	SOMAN
	Sub-Loop Distribution Per 2-Wire Analog Voice Grade Loop - Zone 1		1	UEANL	USBN2	6.46	60.19	21.78	47.50	5.26												
	Sub-Loop Distribution Per 2-Wire Analog Voice Grade Loop - Zone 2		2	UEANL	USBN2	9.18	60.19	21.78	47.50	5.26												
	Sub-Loop Distribution Per 2-Wire Analog Voice Grade Loop - Zone 3		3	UEANL	USBN2	16.29	60.19	21.78	47.50	5.26												
	Order Coordination for Unbundled Sub-Loops, per sub-loop pair			UEANL	USBMC		9.00	9.00														
	Sub-Loop Distribution Per 4-Wire Analog Voice Grade Loop - Zone 1		1	UEANL	USBN4	7.37	68.83	30.42	49.71	6.60												
	Sub-Loop Distribution Per 4-Wire Analog Voice Grade Loop - Zone 2		2	UEANL	USBN4	10.47	68.83	30.42	49.71	6.60												
	Sub-Loop Distribution Per 4-Wire Analog Voice Grade Loop - Zone 3		3	UEANL	USBN4	18.58	68.83	30.42	49.71	6.60												
	Order Coordination for Unbundled Sub-Loops, per sub-loop pair			UEANL	USBMC		9.00	9.00														
	Sub-Loop 2-Wire IntraBuilding Network Cable (INC)			UEANL	USBR2	3.96	51.84	13.44	47.50	5.26												
	Order Coordination for Unbundled Sub-Loops, per sub-loop pair			UEANL	USBMC		9.00	9.00														
	Sub-Loop 4-Wire IntraBuilding Network Cable (INC)			UEANL	USBR4	9.37	55.91	17.51	49.71	6.60												
	Order Coordination for Unbundled Sub-Loops, per sub-loop pair			UEANL	USBMC		9.00	9.00														
	Loop Testing - Basic 1st Half Hour			UEANL	URET1		77.09	0.00														
	Loop Testing - Basic Additional Half Hour			UEANL	URETA		33.12	33.12														
	2 Wire Copper Unbundled Sub-Loop Distribution - Zone 1		1	UEF	UCS2X	5.15	60.19	21.78	47.50	5.26												
	2 Wire Copper Unbundled Sub-Loop Distribution - Zone 2		2	UEF	UCS2X	7.31	60.19	21.78	47.50	5.26												
	2 Wire Copper Unbundled Sub-Loop Distribution - Zone 3		3	UEF	UCS2X	12.98	60.19	21.78	47.50	5.26												
	Order Coordination for Unbundled Sub-Loops, per sub-loop pair			UEF	USBMC		9.00	9.00														
	4 Wire Copper Unbundled Sub-Loop Distribution - Zone 1		1	UEF	UCS4X	5.36	68.83	30.42	49.71	6.60												
	4 Wire Copper Unbundled Sub-Loop Distribution - Zone 2		2	UEF	UCS4X	7.61	68.83	30.42	49.71	6.60												
	4 Wire Copper Unbundled Sub-Loop Distribution - Zone 3		3	UEF	UCS4X	13.51	68.83	30.42	49.71	6.60												
	Order Coordination for Unbundled Sub-Loops, per sub-loop pair			UEF	USBMC		9.00	9.00														
	Loop Tagging Service Level 1, Unbundled Copper Loop, Non-Designed and Distribution Subloops			UEF, UEANL	URETL		8.93	0.88														
	Loop Testing - Basic 1st Half Hour			UEF	URET1		48.65	0.00														
	Loop Testing - Basic Additional Half Hour			UEF	URETA		23.95	23.95														
	<b>Unbundled Sub-Loop Modification</b>																					
	Unbundled Sub-Loop Modification - 2-W Copper Dist Load Coil/Equip Removal per 2-W PR			UEF	ULM2X		10.11	10.11														
	Unbundled Sub-loop Modification - 4-W Copper Dist Load Coil/Equip Removal per 4-W PR			UEF	ULM4X		10.11	10.11														
	Unbundled Loop Modification, Removal of Bridge Tap, per unbundled loop			UEF	ULMBT		15.58	15.58														
	<b>Unbundled Network Terminating Wire (UNTW)</b>																					
	Unbundled Network Terminating Wire (UNTW) per Pair			UENTW	UENPP	0.4572	18.02															
	<b>Network Interface Device (NID)</b>																					
	Network Interface Device (NID) - 1-2 lines			UENTW	UND12		71.49	48.87														
	Network Interface Device (NID) - 1-6 lines			UENTW	UND16		113.89	89.07														
	Network Interface Device Cross Connect - 2 W			UENTW	UNDC2		7.63	7.63														
	Network Interface Device Cross Connect - 4W			UENTW	UNDC4		7.63	7.63														
	<b>UNE OTHER, PROVISIONING ONLY - NO RATE</b>																					
	Unbundled Contact Name, Provisioning Only - no rate			UAL, UCL, UDC, UDL, UDN, UEA, UHL, UEANL, UEF, UEQ, UENTW, NTCVG, NTCUD, NTCD1, USL	UNECD	0.00	0.00															
	Unbundled DS1 Loop - Superframe Format Option - no rate			USL, NTCD1	CCOSF			0.00														
	Unbundled DS1 Loop - Expanded Superframe Format option - no rate			USL, NTCD1	CCOEF			0.00														
	NID - Dispatch and Service Order for NID installation			UENTW	UNDBX	0.00		0.00														
	UNTW Circuit Establishment, Provisioning Only - No Rate			UENTW	UENCE	0.00		0.00														

**UNBUNDLED NETWORK ELEMENTS - Florida**

CATEGORY	RATE ELEMENTS	Interim	Zone	BCS	USOC	RATES(\$)	Svc Order Submitted Elec per LSR	Svc Order Submitted Manually per LSR	Att: 2 Exh: A													
									Incremental Charge - Manual Svc Order vs. Electronic-1st	Incremental Charge - Manual Svc Order vs. Electronic-Add'l	Incremental Charge - Manual Svc Order vs. Electronic-Disc 1st	Incremental Charge - Manual Svc Order vs. Electronic-Disc Add'l	OSS Rates(\$)		SOMEK	SOMAN	SOMAN	SOMAN				
													Rec	Nonrecurring First					Nonrecurring Add'l	Nonrecurring Disconnect First	Nonrecurring Disconnect Add'l	
<b>LOOP MAKE-UP</b>																						
	Loop Makeup - Preordering Without Reservation, per working or spare facility queried (Manual).			UMK	UMKLN	52.17	52.17															
	Loop Makeup - Preordering With Reservation, per spare facility queried (Manual).			UMK	UMKLP	55.07	55.07															
	Loop Makeup-With or Without Reservation, per working or spare facility queried (Mechanized)			UMK	UMKMQ	0.6784	0.6784															
<b>LINE SPLITTING</b>																						
<b>END USER ORDERING-CENTRAL OFFICE BASED</b>																						
	Line Splitting - per line activation DLEC owned splitter			UEPSR	UEPSB	UREOS	0.61															
	Line Splitting - per line activation BST owned - physical			UEPSR	UEPSB	UREBP	0.61	29.68	21.28	19.57	9.61											
	Line Splitting - per line activation BST owned - virtual			UEPSR	UEPSB	UREBV	1.134	29.68	21.28	19.57	9.61											
<b>END USER ORDERING - REMOTE SITE LINE SPLITTING</b>																						
<b>UNBUNDLED EXCHANGE ACCESS LOOP</b>																						
<b>2-WIRE ANALOG VOICE GRADE LOOP</b>																						
	2 Wire Analog Voice Grade Loop-Service Level 1-Line Splitting-Zone 1		1	UEPSR	UEPSB	UEALS	10.69	49.57	22.83	25.62	6.57											
	2 Wire Analog Voice Grade Loop-Service Level 1-Line Splitting-Zone 1		1	UEPSR	UEPSB	UEABS	10.69	49.57	22.83	25.62	6.57											
	2 Wire Analog Voice Grade Loop- Service Level 1-Line Splitting-Zone 2		2	UEPSR	UEPSB	UEALS	15.20	49.57	22.83	25.62	6.57											
	2 Wire Analog Voice Grade Loop- Service Level 1-Line Splitting-Zone 2		2	UEPSR	UEPSB	UEABS	15.20	49.57	22.83	25.62	6.57											
	2 Wire Analog Voice Grade Loop-Service Level 1-Line Splitting-Zone 3		3	UEPSR	UEPSB	UEALS	26.97	49.57	22.83	25.62	6.57											
	2 Wire Analog Voice Grade Loop-Service Level 1-Line Splitting-Zone 3		3	UEPSR	UEPSB	UEABS	26.97	49.57	22.83	25.62	6.57											
<b>PHYSICAL COLLOCATION</b>																						
	Physical Collocation-2 Wire Cross Connects (Loop) for Line Splitting			UEPSR	UEPSB	PE1LS	0.0276	8.22	7.22	5.74	4.58											
<b>VIRTUAL COLLOCATION</b>																						
	Virtual Collocation-2 Wire Cross Connects (Loop) for Line Splitting			UEPSR	UEPSB	VE1LS	0.0502	11.57	11.57	0.00	0.00											
<b>UNBUNDLED DEDICATED TRANSPORT</b>																						
<b>INTEROFFICE CHANNEL - DEDICATED TRANSPORT</b>																						
	Interoffice Channel - 2-Wire Voice Grade - per mile			U1TVX	1L5XX	0.0091																
	Interoffice Channel - 2-Wire Voice Grade - Facility Termination			U1TVX	U1TV2	25.32	47.35	31.78	18.31	7.03												
	Interoffice Channel - 2-Wire Voice Grade Rev Bat. - per mile			U1TVX	1L5XX	0.0091																
	Interoffice Channel - 4-Wire Voice Grade - per mile			U1TVX	1L5XX	0.0091																
	Interoffice Channel - 4-Wire Voice Grade - Facility Termination			U1TVX	U1TV4	22.58	47.35	31.78	18.31	7.03												
	Interoffice Channel - 56 kbps - per mile			U1TDX	1L5XX	0.0091																
	Interoffice Channel - 56 kbps - Facility Termination			U1TDX	U1TD5	18.44	47.35	31.78	18.31	7.03												
	Interoffice Channel - 64 kbps - per mile			U1TDX	1L5XX	0.0091																
	Interoffice Channel - 64 kbps - Facility Termination			U1TDX	U1TD6	18.44	47.35	31.78	18.31	7.03												
	Interoffice Channel- DS1 - per mile			U1TD1	1L5XX	0.1856																
	Interoffice Channel- DS1 - Facility Termination			U1TD1	U1TF1	88.44	105.54	98.47	21.47	19.05												
	Interoffice Channel- DS3 - per mile			U1TD3	1L5XX	3.87																
	Interoffice Channel- DS3 - Facility Termination			U1TD3	U1TF3	1,071.00	335.46	219.28	72.03	70.56												
	Interoffice Channel - STS-1 - per mile			U1TS1	1L5XX	3.87																
	Interoffice Channel - STS-1 - Facility Termination			U1TS1	U1TFS	1,056.00	335.46	219.28	72.03	70.56												
<b>UNBUNDLED DARK FIBER - Stand Alone or in Combination</b>																						
	Dark Fiber - Interoffice Transport, Per Four Fiber Strands, Per Route Mile Or Fraction Thereof			UDF, UDFCX	1L5DF	26.85																
	Dark Fiber - Interoffice Transport, Per Four Fiber Strands, Per Route Mile Or Fraction Thereof			UDF, UDFCX	UDF14		751.34	193.88														
<b>HIGH CAPACITY UNBUNDLED LOCAL LOOP</b>																						
<b>DS-3/STS-1 UNBUNDLED LOCAL LOOP - Stand Alone</b>																						
	DS3 Unbundled Local Loop - per mile			UE3	1L5ND	10.92																
	DS3 Unbundled Local Loop - Facility Termination			UE3	UE3PX	386.88	556.37	343.01	139.13	96.84												
	STS-1 Unbundled Local Loop - per mile			UDLSX	1L5ND	10.92																
	STS-1 Unbundled Local Loop - Facility Termination			UDLSX	UDLS1	426.60	556.37	343.01	139.13	96.84												
<b>ENHANCED EXTENDED LINK (EELs)</b>																						
Network Elements Used in Combinations																						

UNBUNDLED NETWORK ELEMENTS - Florida

CATEGORY	RATE ELEMENTS	Interim	Zone	BCS	USOC	RATES(\$)	Svc Order Submitted Elec per LSR	Svc Order Submitted Manually per LSR	Att: 2 Exh: A											
									Incremental Charge - Manual Svc Order vs. Electronic-1st	Incremental Charge - Manual Svc Order vs. Electronic-Add'l	Incremental Charge - Manual Svc Order vs. Electronic-Disc 1st	Incremental Charge - Manual Svc Order vs. Electronic-Disc Add'l	OSS Rates(\$)							
													SOMECC	SOMAN	SOMAN	SOMAN	SOMAN	SOMAN		
Rec	Nonrecurring First	Nonrecurring Add'l	Nonrecurring First	Nonrecurring Disconnect Add'l	SOMECC	SOMAN	SOMAN	SOMAN	SOMAN	SOMAN										
	2-Wire VG Loop (SL2) in Combination - Zone 1		1	UNCVX	UEAL2	12.24	127.59	60.54	48.00	6.31										
	2-Wire VG Loop (SL2) in Combination - Zone 2		2	UNCVX	UEAL2	17.40	127.59	60.54	48.00	6.31										
	2-Wire VG Loop (SL2) in Combination - Zone 3		3	UNCVX	UEAL2	30.87	127.59	60.54	48.00	6.31										
	4-Wire Analog Voice Grade Loop in Combination - Zone 1		1	UNCVX	UEAL4	18.89	127.59	60.54	48.00	6.31										
	4-Wire Analog Voice Grade Loop in Combination - Zone 2		2	UNCVX	UEAL4	26.84	127.59	60.54	48.00	6.31										
	4-Wire Analog Voice Grade Loop in Combination - Zone 3		3	UNCVX	UEAL4	47.62	127.59	60.54	48.00	6.31										
	2-Wire ISDN Loop in Combination - Zone 1		1	UNCNX	U1L2X	19.28	127.59	60.54	48.00	6.31										
	2-Wire ISDN Loop in Combination - Zone 2		2	UNCNX	U1L2X	27.40	127.59	60.54	48.00	6.31										
	2-Wire ISDN Loop in Combination - Zone 3		3	UNCNX	U1L2X	48.62	127.59	60.54	48.00	6.31										
	4-Wire 56Kbps Digital Grade Loop in Combination - Zone 1		1	UNCDX	UDL56	22.20	127.59	60.54	48.00	6.31										
	4-Wire 56Kbps Digital Grade Loop in Combination - Zone 2		2	UNCDX	UDL56	31.56	127.59	60.54	48.00	6.31										
	4-Wire 56Kbps Digital Grade Loop in Combination - Zone 3		3	UNCDX	UDL56	55.99	127.59	60.54	48.00	6.31										
	4-Wire 64Kbps Digital Grade Loop in Combination - Zone 1		1	UNCDX	UDL64	22.20	127.59	60.54	48.00	6.31										
	4-Wire 64Kbps Digital Grade Loop in Combination - Zone 2		2	UNCDX	UDL64	31.56	127.59	60.54	48.00	6.31										
	4-Wire 64Kbps Digital Grade Loop in Combination - Zone 3		3	UNCDX	UDL64	55.99	127.59	60.54	48.00	6.31										
	4-Wire DS1 Digital Loop in Combination - Zone 1		1	UNC1X	USLXX	70.74	217.75	121.62	51.44	14.45										
	4-Wire DS1 Digital Loop in Combination - Zone 2		2	UNC1X	USLXX	100.54	217.75	121.62	51.44	14.45										
	4-Wire DS1 Digital Loop in Combination - Zone 3		3	UNC1X	USLXX	178.39	217.75	121.62	51.44	14.45										
	DS3 Local Loop in combination - per mile			UNC3X	1L5ND	10.92														
	DS3 Local Loop in combination - Facility Termination			UNC3X	UE3PX	386.88	244.42	154.73	67.10	26.27										
	STS-1 Local Loop in combination - per mile			UNC3X	1L5ND	10.92														
	STS-1 Local Loop in combination - Facility Termination			UNC3X	UDLS1	426.60	244.42	154.73	67.10	26.27										
	Interoffice Channel in combination - 2-wire VG - per mile			UNCVX	1L5XX	0.0091														
	Interoffice Channel in combination - 2-wire VG - Facility Termination			UNCVX	U1TV2	25.32	94.70	52.59	45.28	18.03										
	Interoffice Channel in combination - 4-wire VG - per mile			UNCVX	1L5XX	0.0091														
	Interoffice Channel in combination - 4-wire VG - Facility Termination			UNCVX	U1TV4	22.58	94.70	52.59	45.28	18.03										
	Interoffice Channel in combination - 4-wire 56 kbps - per mile			UNC3X	1L5XX	0.0091														
	Interoffice Channel in combination - 4-wire 56 kbps - Facility Termination			UNC3X	U1TD5	18.44	94.70	52.59	45.28	18.03										
	Interoffice Channel in combination - 4-wire 64 kbps - per mile			UNC3X	1L5XX	0.0091														
	Interoffice Channel in combination - 4-wire 64 kbps - Facility Termination			UNC3X	U1TD6	18.44	94.70	52.59	45.28	18.03										
	Interoffice Channel in combination - DS1 - per mile			UNC1X	1L5XX	0.1856														
	Interoffice Channel in combination - DS1 Facility Termination			UNC1X	U1TF1	88.44	174.46	122.46	45.61	17.95										
	Interoffice Channel in combination - DS3 - per mile			UNC3X	1L5XX	3.87														
	Interoffice Channel in combination - DS3 - Facility Termination			UNC3X	U1TF3	1,071.00	320.00	138.20	38.60	18.81										
	Interoffice Channel in combination - STS-1 - per mile			UNC3X	1L5XX	3.87														
	Interoffice Channel in combination - STS-1 Facility Termination			UNC3X	U1TFS	1,056.00	320.00	138.20	38.60	18.81										
<b>ADDITIONAL NETWORK ELEMENTS</b>																				
<b>Optional Features &amp; Functions:</b>																				
	Clear Channel Capability Extended Frame Option - per DS1		I		U1TD1, ULDD1,UNC1X	CCOEF		0.00												
	Clear Channel Capability Super FrameOption - per DS1		I		U1TD1, ULDD1,UNC1X	CCOSF		0.00												
	Clear Channel Capability (SF/ESF) Option - Subsequent Activity - per DS1		I		ULDD1, U1TD1, UNC1X, USL	NRCCC		184.92	23.82	2.07	0.80									
	C-bit Parity Option - Subsequent Activity - per DS3		i		U1TD3, ULDD3, UE3, UNC3X	NRCC3		219.09	7.67	0.773	0.00									
	DS1/DS0 Channel System				UNC1X	MQ1	146.77	57.28	14.74	1.50	1.34									
	DS3/DS1 Channel System				UNC3X, UNC3X	MQ3	211.19	115.60	56.54	12.16	4.26									
	Voice Grade COCI in combination				UNCVX	1D1VG	1.38	6.71	4.84											
	Voice Grade COCI - for 2W-SL2 & 4W Voice Grade Local Loop				UEA	1D1VG	1.38	6.71	4.84	0.00	0.00									
	Voice Grade COCI - for connection to a channelized DS1 Local Channel in the same SWC as collocation				U1TUC	1D1VG	1.38	6.71	4.84	0.00	0.00									
	OCU-DP COCI (2.4-64kbs) in combination				UNC3X	1D1DD	2.10	6.71	4.84	0.00	0.00									
	OCU-DP COCI (2.4-64kbs) - for Unbundled Digital Loop				UDL	1D1DD	2.10	6.71	4.84	0.00	0.00									
	OCU-DP COCI (2.4-64kbs) - for connection to a channelized DS1 Local Channel in the same SWC as collocation				U1TUD	1D1DD	2.10	6.71	4.84	0.00	0.00									
	2-wire ISDN COCI (BRITE) in combination				UNCNX	UC1CA	3.66	6.71	4.84	0.00	0.00									
	2-wire ISDN COCI (BRITE) - for a Local Loop				UDN	UC1CA	3.66	6.71	4.84	0.00	0.00									

UNBUNDLED NETWORK ELEMENTS - Florida										Att: 2 Exh: A											
CATEGORY	RATE ELEMENTS	Interim	Zone	BCS	USOC	RATES(\$)					Svc Order Submitted Elec per LSR	Svc Order Submitted Manually per LSR	Incremental Charge - Manual Svc Order vs. Electronic-1st	Incremental Charge - Manual Svc Order vs. Electronic-Add'l	Incremental Charge - Manual Svc Order vs. Electronic-Disc 1st	Incremental Charge - Manual Svc Order vs. Electronic-Disc Add'l					
						Rec	Nonrecurring		Nonrecurring Disconnect								OSS Rates(\$)				
							First	Add'l	First	Add'l							SOMEc	SOMAN	SOMAN	SOMAN	SOMAN
	2-wire ISDN COCI (BRITE) - for connection to a channelized DS1 Local Channel in the same SWC as collocation			U1TUB	UC1CA	3.66	6.71	4.84	0.00	0.00											
	DS1 COCI in combination			UNC1X	UC1D1	13.76	6.71	4.84	0.00	0.00											
	DS1 COCI - for Stand Alone Local Channel			ULDD1	UC1D1	13.76	6.71	4.84	0.00	0.00											
	DS1 COCI - for Stand Alone Interoffice Channel			U1TD1	UC1D1	13.76	6.71	4.84	0.00	0.00											
	DS1 COCI - for DS1 Local Loop			USL	UC1D1	13.76	6.71	4.84	0.00	0.00											
	DS1 COCI - for connection to a channelized DS1 Local Channel in the same SWC as collocation			U1TUA	UC1D1	13.76	6.71	4.84	0.00	0.00											
	Wholesale - UNE, Switch-As-Is Conversion Charge			UNCVX, UNCDX, UNC1X, UNC3X, UNCSX, UDFCX, XDH1X, HFQC6, XDD2X, XDV6X, XDDFX, XDD4X, HFRST, UNCNX	UNCCC		8.98	8.98													
	Unbundled Misc Rate Element, SNE SAI, Single Network Element Switch As Is Non-recurring Charge, per circuit (LSR)			U1TVX, U1TDX, U1TD1, U1TD3, U1TS1, UDF, UE3	URESL		8.98	8.98													
	Unbundled Misc Rate Element, SNE SAI, Single Network Element Switch As Is Non-recurring Charge, incremental charge per circuit on a spreadsheet			U1TVX, U1TDX, U1TD1, U1TD3, U1TS1, UDF, UE3	URESP		8.98	8.98													
<b>Access to DCS - Customer Reconfiguration (FlexServ)</b>																					
	Customer Reconfiguration Establishment						1.63		1.63												
	DS1 DCS Termination with DS0 Switching					27.39	32.89	23.58	16.96	12.77											
	DS1 DCS Termination with DS1 Switching					11.70	25.07	15.76	13.05	8.86											
	DS3 DCS Termination with DS1 Switching					146.81	32.89	23.58	16.96	12.77											
<b>Node (SynchroNet)</b>																					
	Node per month			UNCDX	UNCNT	16.35															
<b>Service Rearrangements</b>																					
	NRC - Change in Facility Assignment per circuit Service Rearrangement		I	U1TVX, U1TDX, U1TUC, U1TUD, U1TUB, ULDVX, ULDDX, UNCVX, UNCDX, UNC1X	URETD		101.07	43.04													
	NRC - Change in Facility Assignment per circuit Project Management (added to CFA per circuit if project managed)		I	U1TVX, U1TDX, U1TUC, U1TUD, U1TUB, ULDVX, ULDDX, UNCVX, UNCDX, UNC1X	URETB		3.67	3.67													
	NRC - Order Coordination Specific Time - Dedicated Transport		I	UNC1X, UNC3X	OCOSR		18.90	18.90													
<b>COMMINGLING</b>																					
	Commingling Authorization			UNCVX, UNCDX, UNC1X, UNC3X, UNCSX, U1TD1, U1TD3, U1TS1, UE3, UDLSX, U1TVX, U1TDX, U1TUB, ULDVX, ULDD1, ULDD3, ULDS1	CMGAU	0.00	0.00	0.00	0.00	0.00											
<b>Commingled (UNE part of single bandwidth circuit)</b>																					
	Commingled VG COCI			XDV2X	1D1VG	1.38	6.71	4.84	0.00	0.00											
	Commingled Digital COCI			XDV6X	1D1DD	2.10	6.71	4.84	0.00	0.00											
	Commingled ISDN COCI			XDD4X	UC1CA	3.66	6.71	4.84	0.00	0.00											
	Commingled 2-wire VG Interoffice Channel			XDV2X	U1TV2	25.32	94.70	52.59	45.28	18.03											
	Commingled 4-wire VG Interoffice Channel			XDV6X	U1TV4	22.58	94.70	52.59	45.28	18.03											
	Commingled 56kbps Interoffice Channel			XDD4X	U1TD5	18.44	94.70	52.59	45.28	18.03											
	Commingled 64kbps Interoffice Channel			XDD4X	U1TD6	18.44	94.70	52.59	45.28	18.03											
	Commingled VG/DS0 Interoffice Channel Mileage			XDV2X, XDV6X, XDD4X	1LSXX	0.0091															
	Commingled 2-wire Local Loop Zone 1		1	XDV2X	UEAL2	12.24	127.59	60.54	48.00	6.31											
	Commingled 2-wire Local Loop Zone 2		2	XDV2X	UEAL2	17.40	127.59	60.54	48.00	6.31											
	Commingled 2-wire Local Loop Zone 3		3	XDV2X	UEAL2	30.87	127.59	60.54	48.00	6.31											
	Commingled 4-wire Local Loop Zone 1		1	XDV6X	UEAL4	18.89	127.59	60.54	48.00	6.31											

UNBUNDLED NETWORK ELEMENTS - Florida

CATEGORY	RATE ELEMENTS	Interim	Zone	BCS	USOC	RATES(\$)	Svc Order Submitted Elec per LSR	Svc Order Submitted Manually per LSR	Att: 2 Exh: A				Incremental Charge - Manual Svc Order vs. Electronic-1st	Incremental Charge - Manual Svc Order vs. Electronic-Add'l	Incremental Charge - Manual Svc Order vs. Electronic-Disc 1st	Incremental Charge - Manual Svc Order vs. Electronic-Disc Add'l					
									Rec	Nonrecurring		Nonrecurring Disconnect					OSS Rates(\$)				
										First	Add'l	First					Add'l	SOMEc	SOMAN	SOMAN	SOMAN
	Commingle 4-wire Local Loop Zone 2		2	XDV6X	UEAL4	26.84			127.59	60.54	48.00	6.31									
	Commingle 4-wire Local Loop Zone 3		3	XDV6X	UEAL4	47.62			127.59	60.54	48.00	6.31									
	Commingle 56kbps Local Loop Zone 1		1	XDD4X	UDL56	22.20			127.59	60.54	48.00	6.31									
	Commingle 56kbps Local Loop Zone 2		2	XDD4X	UDL56	31.56			127.59	60.54	48.00	6.31									
	Commingle 56kbps Local Loop Zone 3		3	XDD4X	UDL56	55.99			127.59	60.54	48.00	6.31									
	Commingle 64kbps Local Loop Zone 1		1	XDD4X	UDL64	22.20			127.59	60.54	48.00	6.31									
	Commingle 64kbps Local Loop Zone 2		2	XDD4X	UDL64	31.56			127.59	60.54	48.00	6.31									
	Commingle 64kbps Local Loop Zone 3		3	XDD4X	UDL64	55.99			127.59	60.54	48.00	6.31									
	Commingle ISDN Local Loop Zone 1		1	XDD4X	U1L2X	19.28			127.59	60.54	48.00	6.31									
	Commingle ISDN Local Loop Zone 2		2	XDD4X	U1L2X	27.40			127.59	60.54	48.00	6.31									
	Commingle ISDN Local Loop Zone 3		3	XDD4X	U1L2X	48.62			127.59	60.54	48.00	6.31									
	Commingle DS1 COC1			XDH1X	UC1D1	13.76		6.71		4.84	0.00	0.00									
	Commingle DS1 Interoffice Channel			XDH1X	U1TF1	88.44		174.46		122.46	45.61	17.95									
	Commingle DS1 Interoffice Channel Mileage			XDH1X	1L5XX	0.1856															
	Commingle DS1/DS0 Channel System			XDH1X	MQ1	146.77		57.28		14.74	1.50	1.34									
	Commingle DS1 Local Loop Zone 1		1	XDH1X	USLXX	70.74		217.75		121.62	51.44	14.45									
	Commingle DS1 Local Loop Zone 2		2	XDH1X	USLXX	100.54		217.75		121.62	51.44	14.45									
	Commingle DS1 Local Loop Zone 3		3	XDH1X	USLXX	178.39		217.75		121.62	51.44	14.45									
	Commingle DS3 Local Loop			HFQC6	UE3PX	386.88		244.42		154.73	67.10	26.27									
	Commingle DS3/STS-1 Local Loop Mileage			HFQC6, HFRST	1L5ND	10.92															
	Commingle STS-1 Local Loop			HFRST	UDLS1	426.60		244.42		154.73	67.10	26.27									
	Commingle DS3/DS1 Channel System			HFQC6	MQ3	211.19		115.60		56.54	12.16	4.26									
	Commingle DS3 Interoffice Channel			HFQC6	U1TF3	1,071.00		320.00		138.20	38.60	18.81									
	Commingle DS3 Interoffice Channel Mileage			HFQC6	1L5XX	3.87															
	Commingle STS-1 Interoffice Channel			HFRST	U1TF5	1,056.00		320.00		138.20	38.60	18.81									
	Commingle STS-1 Interoffice Channel Mileage			HFRST	1L5XX	3.87															
	Commingle Dark Fiber - Interoffice Transport, Per Four Fiber Strands, Per Route Mile Or Fraction Thereof			HEQDL	1L5DF	26.85															
	Commingle Dark Fiber - Interoffice Transport, Per Four Fiber Strands, Per Route Mile Or Fraction Thereof			HEQDL	UDF14			751.34		193.88											
	UNE to Commingle Conversion Tracking			XDH1X, HFQC6	CMGUN	0.00		0.00		0.00	0.00	0.00									
	SPA to Commingle Conversion Tracking			XDH1X, HFQC6	CMGSP	0.00		0.00		0.00	0.00	0.00									
<b>LNP Query Service</b>																					
	LNP Charge Per query					0.000852															
	LNP Service Establishment Manual							13.83		13.83	12.71	12.71									
	LNP Service Provisioning with Point Code Establishment							655.50		334.88	297.03	218.40									
<b>911 PBX LOCATE</b>																					
<b>911 PBX LOCATE DATABASE CAPABILITY</b>																					
	Service Establishment per CLEC per End User Account			9PBDC	9PBEU			1,820.00													
	Changes to TN Range or Customer Profile			9PBDC	9PBTN			182.14													
	Per Telephone Number (Monthly)			9PBDC	9PBMM	0.07															
	Change Company (Service Provider) ID			9PBDC	9PBPC			534.66													
	PBX Locate Service Support per CLEC (Monthl)			9PBDC	9PBMR	178.80															
	Service Order Charge			9PBDC	9PBSC			11.90													
<b>911 PBX LOCATE TRANSPORT COMPONENT</b>																					
See Att 3																					
Note: Rates displaying an "I" in Interim column are interim as a result of a Commission order.																					



UNBUNDLED NETWORK ELEMENTS - Florida										Attachment: 2 Exh. B					
CATEGORY	RATE ELEMENTS	Interim	Zone	BCS	USOC	RATES (\$)	Svc Order Submitted Elec per LSR	Svc Order Submitted Manually per LSR	Incremental Charge - Manual Svc Order vs. Electronic-1st	Incremental Charge - Manual Svc Order vs. Electronic-Add'l	Incremental Charge - Manual Svc Order vs. Electronic-Disc 1st	Incremental Charge - Manual Svc Order vs. Electronic-Disc Add'l			
													Rec	Nonrecurring	
										SOMECE	SOMAN	SOMAN	SOMAN	SOMAN	SOMAN
<b>UNBUNDLED EXCHANGE ACCESS LOOP</b>															
<b>2-WIRE HIGH BIT RATE DIGITAL SUBSCRIBER LINE (HDSL) COMPATIBLE LOOP</b>															
	2 Wire Unbundled HDSL Loop including manual service inquiry & facility reservation - Zone 1		1	UHL	UHL2X	8.30									
	2 Wire Unbundled HDSL Loop including manual service inquiry & facility reservation - Zone 2		2	UHL	UHL2X	11.80									
	2 Wire Unbundled HDSL Loop including manual service inquiry & facility reservation - Zone 3		3	UHL	UHL2X	20.94									
	2 Wire Unbundled HDSL Loop without manual service inquiry and facility reservation - Zone 1		1	UHL	UHL2W	8.30									
	2 Wire Unbundled HDSL Loop without manual service inquiry and facility reservation - Zone 2		2	UHL	UHL2W	11.80									
	2 Wire Unbundled HDSL Loop without manual service inquiry and facility reservation - Zone 3		3	UHL	UHL2W	20.94									
<b>4-WIRE HIGH BIT RATE DIGITAL SUBSCRIBER LINE (HDSL) COMPATIBLE LOOP</b>															
	4 Wire Unbundled HDSL Loop including manual service inquiry and facility reservation - Zone 1		1	UHL	UHL4X	12.49									
	4-Wire Unbundled HDSL Loop including manual service inquiry and facility reservation - Zone 2		2	UHL	UHL4X	17.76									
	4-Wire Unbundled HDSL Loop including manual service inquiry and facility reservation - Zone 3		3	UHL	UHL4X	31.50									
	4-Wire Unbundled HDSL Loop without manual service inquiry and facility reservation - Zone 1		1	UHL	UHL4W	12.49									
	4-Wire Unbundled HDSL Loop without manual service inquiry and facility reservation - Zone 2		2	UHL	UHL4W	17.76									
	4-Wire Unbundled HDSL Loop without manual service inquiry and facility reservation - Zone 3		3	UHL	UHL4W	31.50									
<b>4-WIRE DS1 DIGITAL LOOP</b>															
	4-Wire DS1 Digital Loop - Zone 1		1	USL	USLXX	81.35									
	4-Wire DS1 Digital Loop - Zone 2		2	USL	USLXX	115.62									
	4-Wire DS1 Digital Loop - Zone 3		3	USL	USLXX	205.15									
<b>HIGH CAPACITY UNBUNDLED LOCAL LOOP</b>															
	High Capacity Unbundled Local Loop - DS3 - Per Mile per month			UE3	1L5ND	12.56									
	High Capacity Unbundled Local Loop - DS3 - Facility Termination per month			UE3	UE3PX	444.91									
	High Capacity Unbundled Local Loop - STS-1 - Per Mile per month			UDLSX	1L5ND	12.56									
	High Capacity Unbundled Local Loop - STS-1 - Facility Termination per month			UDLSX	UDLS1	490.59									
<b>UNBUNDLED DEDICATED TRANSPORT</b>															
<b>INTEROFFICE CHANNEL - DEDICATED TRANSPORT</b>															
	Interoffice Channel - Dedicated Channel - DS1 - Per Mile per month			U1TD1	1L5XX	0.21									
	Interoffice Channel - Dedicated Transport - DS1 - Facility Termination			U1TD1	U1TF1	101.71									
	Interoffice Channel - Dedicated Transport - DS3 - Per Mile per month			U1TD3	1L5XX	4.45									
	Interoffice Channel - Dedicated Transport - DS3 - Facility Termination per month			U1TD3	U1TF3	1231.65									
	Interoffice Channel - Dedicated Transport - STS-1 - Per Mile per month			U1TS1	1L5XX	4.45									
	Interoffice Channel - Dedicated Transport - STS-1 - Facility Termination			U1TS1	U1TFS	1214.40									
<b>UNBUNDLED DARK FIBER - Stand Alone or in Combination</b>															
	Dark Fiber - Interoffice Transport, Per Four Fiber Strands, Per Route Mile Or Fraction Thereof			UDF, UDFCX	1L5DF	30.88									
<b>ENHANCED EXTENDED LINK (EELs)</b>															



**BellSouth's Master List of Unimpaired Wire Centers as Approved by State Commissions in its Region  
(Revised pursuant to Carrier Notification Letter SN91087013)**

State	Wire Center	Total Business Lines	Number of FB Collocators excluding AT&T and SBC and fiber-to-fiber collo if 3 or greater	Tier 1	Tier 2	No Impairment for DS3 Loops	No Impairment for DS1 loops
AL	MTGMALMT	27,528			X		
AL	MTGMALDA	32,752			X		
AL	MOBLALAZ	20,101	>3	X			
AL	HNVIALMT	26,690			X		
AL	BRHMALMT	39,078		X			
FL	BCRTFLBT	26,601			X		
FL	BCRTFLMA	40,746	>3	X		X	
FL	COCOFLMA	18,097	>3	X			
FL	DRBHFLMA	24,695			X		
FL	DYBHFLMA	32,282	>3	X			
FL	FTLDFLCY	31,487			X		
FL	FTLDFLJA	29,209	3		X		
FL	FTLDFLMR	55,881	>3	X		X	
FL	FTLDFLOA	23,008	3		X		
FL	FTLDFLPL	29,469	-		X		
FL	GSVFLMA	55,681	3	X			
FL	HLWDFLPE	37,415	3		X		
FL	HLWDFLWH	34,022			X		
FL	JCVLFLCL	42,452	>3	X		X	
FL	JCVLFLSJ	24,088	3		X		
FL	JCVLFLSM	17,820	>3	X			
FL	MIAMFLAE	41,912	3	X			
FL	MIAMFLBR	24,482			X		
FL	MIAMFLGR	68,580	>3	X		X	X
FL	MIAMFLHL	43,021	3	X			
FL	MIAMFLPB	24,380			X		
FL	MIAMFLPL	86,923	>3	X		X	X
FL	MIAMFLRR	24,740			X		
FL	MIAMFLWM	23,310	3		X		
FL	MLBRFLMA	32,547	>3	X			
FL	NDADFLGG	18,239	>3	X			
FL	ORLDFLAP	31,234			X		
FL	ORLDFLCL	20,828	>3	X			
FL	ORLDFLMA	57,966	>3	X		X	
FL	ORLDFLPC	45,792	>3	X		X	
FL	ORLDFLPH	33,148	3		X		
FL	ORLDFLSA	26,126	>3	X			
FL	PMBHFLFE	25,909			X		
FL	PMBHFLMA	33,993			X		
FL	PNSCFLBL	28,685	3		X		
FL	PNSCFLFP	30,863			X		
FL	PRRNFLMA	37,969			X		
FL	STRTFLMA	25,577			X		
FL	WPBHFLAN	33,521			X		
FL	WPBHFLGA	24,885			X		

**BellSouth's Master List of Unimpaired Wire Centers as Approved by State Commissions in its Region  
(Revised pursuant to Carrier Notification Letter SN91087013)**

State	Wire Center	Total Business Lines	Number of FB Collocators excluding AT&T and SBC and fiber-to-fiber collo if 3 or greater	Tier 1	Tier 2	No Impairment for DS3 Loops	No Impairment for DS1 loops
FL	WPBHFLGR	26,527	3		X		
FL	WPBHFLHH	36,053			X		
GA	TUKRGAMA	27,383			X		
GA	SVNHGABS	28,626	3		X		
GA	SMYRGAPP	52,246	>3	X		X	
GA	SMYRGAMA	29,316	>3	X			
GA	RSWLGAMA	41,390		X			
GA	NRCRGAMA	78,131	>3	X		X	X
GA	MRTTGAMA	89,220		X			
GA	MACNGAMT	24,148			X		
GA	LRVLGAOS	32,076			X		
GA	LLBNGAMA	27,481			X		
GA	DNWDGAMA	47,862	>3	X		X	
GA	DLTHGAHS	39,907		X			
GA	CMNGGAMA	24,408			X		
GA	CLMBGAMT	36,081			X		
GA	CHMBGAMA	30,860			X		
GA	ATLNGATH	33,131			X		
GA	ATLNGASS	33,797			X		
GA	ATLNGAPP	71,905	>3	X		X	X
GA	ATLNGAEP	34,260	3		X		
GA	ATLNGACS	94,988	>3	X		X	X
GA	ATLNGABU	57,064	>3	X		X	
GA	ATHNGAMA	28,311			X		
GA	ALPRGAMA	74,317	>3	X		X	X
GA	ALBYGAMA	29,095			X		
LA	SHPTLAMA	29,790	>3	X			
LA	MONRLAMA	37,785			X		
LA	LFYTLAMA	46,825		X			
LA	BTRGLAMA	39,089	3	X			
LA	BTRGLAGW	39,525		X			
MS	JCSNMSCP	40,109	3	X			
MS	HTBGMSMA	12,829	3		X		
NC	WNSLNCFI	28,298	3		X		
NC	SLBRNCMA	10,173	3		X		
NC	RLGHNCMO	64,715	>3	X		X	X
NC	RLGHNCHO	21,749	>3	X			
NC	RLGHNCGL	19,043	>3	X			
NC	GNBONCEU	38,039	>3	X		X	
NC	GNBONCAS	26,022	>3	X			
NC	CPHLNCRO	37,831	>3	X			
NC	CHRLNCUN	11,642	3		X		
NC	CHRLNCSH	9,924	>3	X			
NC	CHRLNCRE	8,097	>3	X			
NC	CHRLNCLP	6,884	>3	X			

**BellSouth's Master List of Unimpaired Wire Centers as Approved by State Commissions in its Region  
(Revised pursuant to Carrier Notification Letter SN91087013)**

State	Wire Center	Total Business Lines	Number of FB Collocators excluding AT&T and SBC and fiber-to-fiber collo if 3 or greater	Tier 1	Tier 2	No Impairment for DS3 Loops	No Impairment for DS1 loops
NC	CHRLNCCA	57,856	>3	X		X	
NC	CHRLNCBO	17,322	>3	X			
NC	CARYNCCE	20,783	>3	X			
SC	SPBGSCMA	22,796	3		X		
SC	MNPLSCES	24,061			X		
SC	GNVLSCLR	33,639			X		
SC	GNVLSCLDT	45,546	>3	X		X	
SC	CLMASCNS	48,403	>3	X		X	
SC	CLMASCNSA	13,939	3		X		
SC	CHTNSCNO	24,107			X		
SC	CHTNSCLDT	24,703	>3	X			

**Attachment 3**  
**Network Interconnection**

## TABLE OF CONTENTS

<b>1</b>	<b>General .....</b>	<b>3</b>
<b>2</b>	<b>Definitions: (For the purpose of this Attachment).....</b>	<b>3</b>
<b>3</b>	<b>Network Interconnection .....</b>	<b>5</b>
<b>4</b>	<b>Interconnection Trunk Group Architectures.....</b>	<b>7</b>
<b>5</b>	<b>Network Design And Management For Interconnection.....</b>	<b>14</b>
<b>6</b>	<b>Forecasting for Trunk Provisioning.....</b>	<b>14</b>
<b>7</b>	<b>Local Dialing Parity .....</b>	<b>17</b>
<b>8</b>	<b>Interconnection Compensation.....</b>	<b>17</b>
<b>9</b>	<b>Ordering Charges.....</b>	<b>23</b>
<b>10</b>	<b>Basic 911 and E911 Interconnection .....</b>	<b>23</b>
<b>11</b>	<b>SS7 Network Interconnection .....</b>	<b>24</b>
	<b>Rates</b>	<b>Exhibit A</b>
	<b>Basic Architecture</b>	<b>Exhibit B</b>
	<b>One Way Architecture</b>	<b>Exhibit C</b>
	<b>Two Way Architecture</b>	<b>Exhibit D</b>
	<b>Supergroup Architecture</b>	<b>Exhibit E</b>

## NETWORK INTERCONNECTION

### 1 General

1.1 The Parties shall provide interconnection with each other's networks for the transmission and routing of telephone exchange service (Local Traffic), ISP-Bound Traffic, and exchange access (Switched Access Traffic) on the following terms:

### 2 Definitions: (For the purpose of this Attachment)

For purposes of this attachment only, the following terms shall have the definitions set forth below:

- 2.1 **Automatic Location Identification (ALI)** is a feature by which the address associated with the calling party's telephone number (ANI) is forwarded to the PSAP for display. Access to the ALI database is described in Attachment 2 to this Agreement.
- 2.2 **Automatic Number Identification (ANI)** corresponds to the seven-digit telephone number assigned by the serving local exchange carrier.
- 2.3 **BellSouth Trunk Group** is defined as a one-way trunk group carrying BellSouth originated traffic to be terminated by Smart City Communications.
- 2.4 **911 Service** is as described in this Attachment.
- 2.5 **Call Termination** has the meaning set forth for "termination" in 47 C.F.R. § 51.701(d).
- 2.6 **Call Transport** has the meaning set forth for "transport" in 47 C.F.R. § 51.701(c).
- 2.7 **Call Transport and Termination** is used collectively to mean the switching and transport functions from the Interconnection Point to the last point of switching.
- 2.8 **Common (Shared) Transport** is defined as the transport of the originating Party's traffic by the terminating Party over the terminating Party's common (shared) facilities between (1) the terminating Party's tandem switch and end office switch, (2) between the terminating Party's tandem switches, and/or (3) between the terminating Party's host and remote end office switches. All switches referred herein must be entered into the The Telcordia® LERG™ Routing Guide (LERG).
- 2.9 **Dedicated Interoffice Facility** is defined as a switch transport facility between a Party's Serving Wire Center and the first point of switching within the LATA on the other Party's network.
- 2.10 **End Office Switching** is defined as the function that establishes a communications path between the trunk side and line side of the End Office switch.



- 2.11 **Fiber Meet** is an interconnection arrangement whereby the Parties physically interconnect their networks via an optical fiber interface at which one Party's facilities, provisioning, and maintenance responsibility begins and the other Party's responsibility ends.
- 2.12 **Final Trunk Group** is defined as the last choice trunk group between two (2) switches for which there is no alternate route.
- 2.13 **Integrated Services Digital Network User Part (ISUP)** is a message protocol to support call set-up and release for interoffice voice connections over SS7 signaling.
- 2.14 **Interconnection Point (IP)** is the physical telecommunications equipment interface that interconnects the networks of BellSouth and Smart City Communications for the exchange of telecommunications traffic between the Parties.
- 2.15 **IntraLATA Toll Traffic** is as defined in this Attachment.
- 2.16 **ISP-Bound Traffic** is as defined in this Attachment.
- 2.17 **Local Channel** is defined as a switched transport facility between a Party's Interconnection Point and the IP's Serving Wire Center.
- 2.18 **Local Traffic** is as defined in this Attachment.
- 2.19 **Public Safety Answering Point (PSAP)** is the answering location for 911 calls.
- 2.20 **Selective Routing (SR)** is a standard feature that routes an E911 call from the tandem to the designated PSAP based upon the address of the ANI of the calling party.
- 2.21 **Serving Wire Center (SWC)** is defined as the wire center owned by one Party from which the other Party would normally obtain dial tone for its IP.
- 2.22 **Signaling System 7 (SS7)/Common Channel Signaling 7 (CCS7)** is an out-of-band signaling system used to provide basic routing information, call set-up and other call termination functions. Signaling is removed from the voice channel and put on a separate data network.
- 2.23 **Tandem Switching** is defined as the function that establishes a communications path between two switching offices through a third switching office through the provision of trunk side to trunk side switching.
- 2.24 **Transit Traffic** is traffic originating on Smart City Communications's network that is switched and/or transported by BellSouth and delivered to a third party's

network, or traffic originating on a third party's network that is switched and/or transported by BellSouth and delivered to Smart City Communications's network.

### **3 Network Interconnection**

- 3.1 This Attachment pertains only to the provision of network interconnection where Smart City Communications owns, leases from a third party or otherwise provides its own switch(es).
- 3.2 Network interconnection may be provided by the Parties at any technically feasible point within BellSouth's network. Requests to BellSouth for interconnection at points other than as set forth in this Attachment may be made through the Bona Fide Request/New Business Request (BFR/NBR) Process set forth in Attachment 11.
- 3.2.1 Each Party is responsible for providing, engineering and maintaining the network on its side of the IP. The IP must be located within BellSouth's serving territory in the LATA in which traffic is originating. The IP determines the point at which the originating Party shall pay the terminating Party for the Call Transport and Termination of Local Traffic, ISP-Bound Traffic and IntraLATA Toll Traffic. In selecting the IP, both Parties will act in good faith and select the point that is most efficient for both Parties.
- 3.2.2 Pursuant to the provisions of this Attachment, the location of the initial IP in a given LATA shall be established by mutual agreement of the Parties. Subject to the requirements for installing additional IPs, as set forth below, any IPs existing prior to the Effective Date of the Agreement will be accepted as initial IPs and will not require re-grooming. When the Parties mutually agree to utilize two-way interconnection trunk groups for the exchange of Local Traffic, ISP-Bound Traffic and IntraLATA Toll Traffic between each other, the Parties shall mutually agree to the location of IP(s). If the Parties are unable to agree to a mutual initial IP, each Party, as originating Party, shall establish a single IP in the LATA for the delivery of its originated Local Traffic, ISP-Bound Traffic and IntraLATA Toll Traffic to the other Party for Call Transport and Termination by the terminating Party.
- 3.2.3 Additional IP(s) in a LATA may be established by mutual agreement of the Parties. Notwithstanding the foregoing, additional IP(s) in a particular LATA shall be established, at the request of either Party, when the Local Traffic and ISP-Bound Traffic exceeds eight point nine (8.9) million minutes per month for three (3) consecutive months at the proposed location of the additional IP. BellSouth will not request the establishment of an IP in a BellSouth Central Office where physical or virtual collocation space is not available or where BellSouth fiber connectivity is not available. When the Parties agree to utilize two-way interconnection trunk groups for the exchange of Local Traffic, ISP-Bound Traffic and IntraLATA Toll Traffic the Parties must agree to the location of the IP(s).

- 3.3 Interconnection via Dedicated Facilities
- 3.3.1 Local Channel Facilities. As part of Call Transport and Termination, the originating Party may obtain Local Channel facilities from the terminating Party. The percentage of Local Channel facilities utilized for Local Traffic and ISP-Bound Traffic shall be determined based upon the application of the Percent Local Facility (PLF) Factor as set forth in this Attachment. The charges applied to the percentage of Local Channel facilities used for Local Traffic and ISP-Bound Traffic as determined by the PLF factor are as set forth in Exhibit A. The remaining percentage of Local Channel facilities shall be billed at BellSouth's intrastate Access Services Tariff or BellSouth's FCC No. 1 Tariff rates.
- 3.3.2 Dedicated Interoffice Facilities. As a part of Call Transport and Termination, the originating Party may obtain Dedicated Interoffice Facilities from the terminating Party. The percentage of Dedicated Interoffice Facilities utilized for Local Traffic and ISP-Bound Traffic shall be determined based upon the application of the PLF factor as set forth in this Attachment. The charges applied to the percentage of the Dedicated Interoffice Facilities used for Local Traffic and ISP-Bound Traffic as determined by the PLF factor are as set forth in Exhibit A. The remaining percentage of the Dedicated Interoffice Facilities shall be billed at BellSouth's intrastate Access Services Tariff or BellSouth's FCC No. 1 Tariff rates.
- 3.4 Fiber Meet. Notwithstanding Sections 3.2.1, 3.2.2, and 3.2.3 above, if Smart City Communications elects to establish interconnection with BellSouth pursuant to a Fiber Meet Local Channel, Smart City Communications and BellSouth shall jointly engineer, operate and maintain a Synchronous Optical Network (SONET) transmission system by which they shall interconnect their transmission and routing of Local Traffic and ISP-Bound Traffic via a Local Channel at either the DS1 or DS3 level. The Parties shall work jointly to determine the specific transmission system. However, Smart City Communications's SONET transmission system must be compatible with BellSouth's equipment, and the Data Communications Channel (DCC) must be turned off.
- 3.4.1 Each Party, at its own expense, shall procure, install and maintain the agreed upon SONET transmission system in its network.
- 3.4.2 The Parties shall agree to a Fiber Meet point between the BellSouth Serving Wire Center and the Smart City Communications Serving Wire Center. The Parties shall deliver their fiber optic facilities to the Fiber Meet point with sufficient spare length to reach the fusion splice point for the Fiber Meet point. BellSouth shall, at its own expense, provide and maintain the fusion splice point for the Fiber Meet. A building type CLLI code will be established for each Fiber Meet point. All orders for interconnection facilities from the Fiber Meet point shall indicate the Fiber Meet point as the originating point for the facility.
- 3.4.3 Upon verbal request by Smart City Communications, BellSouth shall allow Smart City Communications access to the fusion splice point for the Fiber Meet point for

maintenance purposes on Smart City Communications's side of the Fiber Meet point.

- 3.4.4 Neither Party shall charge the other for its Local Channel portion of the Fiber Meet facility used exclusively for Local Traffic and ISP-Bound Traffic. The percentage of Local Channel facilities utilized for Local Traffic and ISP-Bound Traffic shall be determined based upon the application of the PLF factor as set forth in this Attachment. The charges applied to the percentage of Local Channel facilities used for Local Traffic and ISP-Bound Traffic as determined by the PLF factor are as set forth in Exhibit A. The remaining percentage of Local Channel facilities shall be billed at BellSouth's applicable access tariff rates. Charges for switched and special access services shall be billed in accordance with the applicable BellSouth intrastate Access Services Tariff and or BellSouth's FCC No. 1 Tariff.

#### **4 Interconnection Trunk Group Architectures**

- 4.1 BellSouth and Smart City Communications shall establish interconnecting trunk groups and trunk group configurations between networks, including the use of one-way or two-way trunks in accordance with the following provisions set forth in this Attachment. For trunking purposes, traffic will be routed based on the digits dialed by the originating end user and in accordance with the LERG.
- 4.2 Smart City Communications shall establish an interconnection trunk group(s) to at least one (1) BellSouth access tandem within the LATA for the delivery of Smart City Communications's originated Local Traffic, ISP-Bound Traffic and IntraLATA Toll Traffic and for the receipt and delivery of Transit Traffic. To the extent Smart City Communications desires to deliver Local Traffic, ISP-Bound Traffic, IntraLATA Toll Traffic and/or Transit Traffic to BellSouth access tandems within the LATA, other than the tandems(s) to which Smart City Communications has established interconnection trunk groups, Smart City Communications shall pay the appropriate rates for Multiple Tandem Access, as described in this Attachment.
- 4.2.1 Notwithstanding the forgoing, Smart City Communications shall establish an interconnection trunk group(s) to all BellSouth access and local tandems in the LATA where Smart City Communications has homed (i.e., assigned) its NPA/NXXs. Smart City Communications shall home its NPA/NXXs on the BellSouth tandems that serve the exchange rate center areas to which the NPA/NXXs are assigned. The specified exchange rate center assigned to each BellSouth tandem is defined in the LERG. Smart City Communications shall enter its NPA/NXX access and/or local tandem homing arrangements into the LERG.
- 4.3 Switched access traffic will be delivered to and from IXCs based on Smart City Communications's NXX access tandem homing arrangement as specified by Smart City Communications in the LERG.

- 4.4 Any Smart City Communications interconnection request that (1) deviates from the interconnection trunk group architectures as described in this Agreement, (2) affects traffic delivered to Smart City Communications from a BellSouth switch, and (3) requires special BellSouth switch translations and other network modifications will require Smart City Communications to submit a BFR/NBR via the BFR/NBR Process as set forth in Attachment 11.
- 4.5 Recurring and nonrecurring rates associated with interconnecting trunk groups between BellSouth and Smart City Communications are set forth in Exhibit A. To the extent a rate associated with the interconnecting trunk group is not set forth in Exhibit A, the rate shall be as set forth in the appropriate BellSouth intrastate Access Services Tariff or BellSouth's FCC No. 1 Tariff.
- 4.6 For two-way trunk groups that carry only both Parties' Local Traffic, the Parties shall be compensated at fifty percent (50%) of the nonrecurring and recurring rates for dedicated trunks and DS1 facilities. Smart City Communications shall be responsible for ordering and paying for any two-way trunks carrying Transit Traffic.
- 4.7 All trunk groups will be provisioned as SS7 capable where technically feasible. If SS7 is not technically feasible, multi-frequency (MF) protocol signaling shall be used.
- 4.8 In cases where Smart City Communications is also an IXC, the IXC's Feature Group D (FG D) trunk group(s) must remain separate from the local interconnection trunk group(s).
- 4.9 Each Party shall order interconnection trunks and trunk group including trunk and trunk group augmentations via the Access Service Request (ASR) process. A Firm Order Confirmation (FOC) shall be returned to the ordering Party, after receipt of a valid, error free ASR, within the timeframes set forth in each state's applicable Performance Measures. Notwithstanding the foregoing, blocking situations and projects shall be managed through BellSouth's Carrier Interconnection Switching Center (CISC) Project Management Group and Smart City Communications's equivalent trunking group, and FOCs for such orders shall be returned in the timeframes applicable to the project. A project is defined as (1) a new trunk group or (2) a request for more than one hundred ninety-two (192) trunks on a single or multiple group(s) in a given BellSouth local calling area.
- 4.10 Interconnection Trunk Groups for Exchange of Local Traffic and Transit Traffic
- 4.10.1 Upon mutual agreement of the Parties in a joint planning meeting, the Parties shall exchange Local Traffic on two-way interconnection trunk group(s) with the quantity of trunks being mutually determined and the provisioning being jointly coordinated. Furthermore, the Parties shall agree upon the IP(s) for two-way interconnection trunk groups transporting both Parties' Local Traffic, ISP-Bound Traffic and IntraLATA Toll Traffic. Smart City Communications shall order such

two-way trunks via the ASR process. BellSouth will use the Trunk Group Service Request (TGSR) to request changes in trunking. Furthermore, the Parties shall jointly review trunk performance and forecasts in accordance with Section 6 below. The Parties' use of two-way interconnection trunk groups for the transport of Local Traffic, ISP-Bound Traffic and IntraLATA Toll Traffic between the Parties does not preclude either Party from establishing additional one-way interconnection trunks for the delivery of its originated Local Traffic, ISP-Bound Traffic and IntraLATA Toll Traffic to the other Party. Other trunk groups for operator services, directory assistance and intercept must be established pursuant to BellSouth's intrastate Access Services Tariff and/or BellSouth's FCC No. 1 Tariff.

- 4.10.2 BellSouth Access Tandem Interconnection. BellSouth Access Tandem interconnection at a single Access Tandem provides access to those End Offices subtending that access tandem (Intratandem Access). Access Tandem interconnection is available for any of the following access tandem architectures:
- 4.10.2.1 Basic Architecture. In the basic architecture, Smart City Communications's originating Local Traffic, ISP-Bound Traffic and IntraLATA Toll Traffic and originating and terminating Transit Traffic is transported on a single two-way trunk group between Smart City Communications and BellSouth Access Tandem(s) within a LATA to provide Intratandem Access. This trunk group carries Transit Traffic between Smart City Communications and ICOs, IXCs, other CLECs, CMRS providers that have a Meet Point Billing arrangement with BellSouth, and other network providers with which Smart City Communications desires to exchange traffic. This trunk group also carries Smart City Communications originated Transit Traffic transiting a single BellSouth Access Tandem destined to third party tandems such as an ICO tandem or other CLEC tandem. BellSouth originated Local Traffic, ISP-Bound Traffic and IntraLATA Toll Traffic is transported on a separate single one-way trunk group terminating to Smart City Communications. The LERG contains current routing and tandem serving arrangements. The basic Architecture is illustrated in Exhibit B.
- 4.10.2.2 One-Way Trunk Group Architecture. In one-way trunk group architecture, the Parties interconnect using three (3) separate trunk groups. A one-way trunk group provides Intratandem Access for Smart City Communications-originated Local Traffic, ISP-Bound Traffic and IntraLATA Toll Traffic destined for BellSouth end users. A second one-way trunk group carries BellSouth-originated Local Traffic, ISP-Bound Traffic and IntraLATA Toll Traffic destined for Smart City Communications end users. A two-way trunk group provides Intratandem Access for Smart City Communications's originating and terminating Transit Traffic. This trunk group carries Transit Traffic between Smart City Communications and ICOs, IXCs, other CLECs, CMRS providers that have a Meet Point Billing arrangement with BellSouth, and other network providers with which Smart City Communications exchanges traffic. This trunk group also carries Smart City Communications originated Transit Traffic transiting a single BellSouth Access

Tandem destined to third party tandems such as an ICO tandem or other CLEC tandem. BellSouth originated Local Traffic, ISP-Bound Traffic and IntraLATA Toll Traffic is transported on a separate single one-way trunk group terminating to Smart City Communications. The LERG contains current routing and tandem serving arrangements. The one-way trunk group architecture is illustrated in Exhibit C.

- 4.10.2.3 Two-Way Trunk Group Architecture. The two-way trunk group Architecture establishes one (1) two-way trunk group to provide IntraTandem Access for the exchange of Local Traffic, ISP-Bound Traffic and IntraLATA Toll Traffic between Smart City Communications and BellSouth. In addition, a separate two-way transit trunk group must be established for Smart City Communications's originating and terminating Transit Traffic. This trunk group carries Transit Traffic between Smart City Communications and ICOs, IXCs, other CLECs, CMRS providers that have a Meet Point Billing arrangement with BellSouth, and other network providers with which Smart City Communications exchanges traffic. This trunk group also carries Smart City Communications originated Transit Traffic transiting a single BellSouth Access Tandem destined to third party tandems such as an ICO tandem or other CLEC tandem. BellSouth originated traffic may, in order to prevent or remedy traffic blocking situations, be transported on a separate single one-way trunk group terminating to Smart City Communications. However, where Smart City Communications is responsive in a timely manner to BellSouth's transport needs for its originated traffic, BellSouth originating traffic will be placed on the two-way Local Traffic trunk group carrying ISP-Bound Traffic and IntraLATA Toll Traffic. The LERG contains current routing and tandem serving arrangements. The two-way trunk group architecture is illustrated in Exhibit D.
- 4.10.2.4 Supergroup Architecture. In the supergroup architecture, the Parties' Local Traffic, ISP-Bound Traffic and IntraLATA Toll Traffic and Smart City Communications's Transit Traffic are exchanged on a single two-way trunk group between Smart City Communications and BellSouth to provide IntraTandem Access to Smart City Communications. This trunk group carries Transit Traffic between Smart City Communications and ICOs, IXCs, other CLECs, CMRS providers that have a Meet Point Billing arrangement with BellSouth, and other network providers with which Smart City Communications desires to exchange traffic. This trunk group also carries Smart City Communications originated Transit Traffic transiting a single BellSouth Access Tandem destined to third party tandems such as an ICO tandem or other CLEC tandem. BellSouth originated traffic may, in order to prevent or remedy traffic blocking situations, be transported on a separate single one-way trunk group terminating to Smart City Communications. However, where Smart City Communications is responsive in a timely manner to BellSouth's transport needs for its originated traffic, BellSouth originating traffic will be placed on the Supergroup. Other trunk groups for operator services, directory assistance, emergency services and intercept must be established pursuant to the applicable BellSouth tariff if service is requested. The

LERG contains current routing and tandem serving arrangements. The supergroup architecture is illustrated in Exhibit E.

#### 4.10.2.5 Multiple Tandem Access (MTA) Interconnection

4.10.2.5.1 Where Smart City Communications does not choose access tandem interconnection at every BellSouth Access Tandem within a LATA, Smart City Communications must utilize BellSouth's MTA interconnection. To utilize MTA Smart City Communications must establish an interconnection trunk group(s) at a minimum of one (1) BellSouth Access Tandem within each LATA as required. BellSouth will route Smart City Communications's originated Local Traffic, ISP-Bound Traffic and IntraLATA Toll Traffic for LATA wide transport and termination. Smart City Communications must also establish an interconnection trunk group(s) at all BellSouth Access Tandems where Smart City Communications NXXs are homed as described in Section 4.2.1 above. If Smart City Communications does not have NXXs homed at any particular BellSouth Access Tandem within a LATA and elects not to establish an interconnection trunk group(s) at such BellSouth Access Tandem, Smart City Communications can order MTA in each BellSouth Access Tandem within the LATA where it does have an interconnection trunk group(s) and BellSouth will terminate Smart City Communications's Local Traffic, ISP-Bound Traffic and IntraLATA Toll Traffic to end users served through those BellSouth Access Tandems where Smart City Communications does not have an interconnection trunk group(s). MTA shall be provisioned in accordance with BellSouth's Ordering Guidelines.

4.10.2.5.2 Smart City Communications may also utilize MTA to route its originated Transit Traffic; provided, however, that MTA may not be utilized to route switched access traffic that transits the BellSouth network to an IXC. Switched access traffic originated by or terminated to Smart City Communications will be delivered to and from IXCs based on Smart City Communications's NXX access tandem homing arrangement as specified by Smart City Communications in the LERG.

4.10.2.5.3 Compensation for MTA shall be at the applicable tandem switching and transport charges specified in Exhibit A and shall be billed in addition to any Call Transport and Termination charges.

4.10.2.5.4 To the extent Smart City Communications does not purchase MTA in a LATA served by multiple Access Tandems, Smart City Communications must establish an interconnection trunk group(s) to every Access Tandem in the LATA to serve the entire LATA. To the extent Smart City Communications routes its traffic in such a way that utilizes BellSouth's MTA service without properly ordering MTA, Smart City Communications shall pay BellSouth the associated MTA charges.

#### 4.10.3 Local Tandem Interconnection

4.10.3.1 Local Tandem Interconnection arrangement allows Smart City Communications to establish an interconnection trunk group(s) at BellSouth local tandems for: (1) the



delivery of Smart City Communications-originated Local Traffic and ISP-Bound Traffic transported and terminated by BellSouth to BellSouth End Offices served by those BellSouth local tandems, and (2) for local Transit Traffic transported by BellSouth for third party network providers who have also established an interconnection trunk group(s) at those BellSouth local tandems.

- 4.10.3.2 When a specified local calling area is served by more than one (1) BellSouth local tandem, Smart City Communications must designate a “home” local tandem for each of its assigned NPA/NXXs and establish trunk connections to such local tandems. Additionally, Smart City Communications may choose to establish an interconnection trunk group(s) at the BellSouth local tandems where it has no codes homing but is not required to do so. Smart City Communications may deliver Local Traffic and ISP-Bound Traffic to a “home” BellSouth local tandem that is destined for other BellSouth or third party network provider end offices subtending other BellSouth local tandems in the same local calling area where Smart City Communications does not choose to establish an interconnection trunk group(s). It is Smart City Communications’s responsibility to enter its own NPA/NXX local tandem homing arrangements into the LERG either directly or via a vendor in order for other third party network providers to determine appropriate traffic routing to Smart City Communications’s codes. Likewise, Smart City Communications shall obtain its routing information from the LERG.
- 4.10.3.3 Notwithstanding establishing an interconnection trunk group(s) to BellSouth’s local tandems, Smart City Communications must also establish an interconnection trunk group(s) to BellSouth Access Tandems within the LATA on which Smart City Communications has NPA/NXXs homed for the delivery of Interexchange Carrier Switched Access and toll traffic, and traffic to Type 2A CMRS connections located at the Access Tandems. BellSouth shall not switch SWA traffic through more than one BellSouth access tandem. SWA, Type 2A CMRS or toll traffic routed to the local tandem in error will not be backhauled to the BellSouth Access Tandem for completion. (Type 2A CMRS interconnection is defined in Section A35 of BellSouth’s GSST).
- 4.10.3.4 BellSouth’s provisioning of Local Tandem Interconnection assumes that Smart City Communications has executed the necessary local interconnection agreements with the other third party network providers subtending those local tandems as required by the Act.
- 4.10.4 Direct End Office-to-End Office Interconnection
- 4.10.4.1 Direct End Office-to-End Office one-way or two-way interconnection trunk groups allow for the delivery of a Party’s originating Local Traffic, ISP-Bound Traffic and IntraLATA Toll Traffic to the terminating Party on a direct end office-to-end office basis.
- 4.10.4.2 The Parties shall utilize direct end office-to-end office trunk groups under any one (1) of the following conditions:

- 4.10.4.2.1 Tandem Exhaust. If a tandem through which the Parties are interconnected is unable to, or is forecasted to be unable to support additional traffic loads for any period of time, the Parties will mutually agree on an end office trunking plan that will alleviate the tandem capacity shortage and ensure completion of traffic between Smart City Communications and BellSouth.
- 4.10.4.2.2 Traffic Volume. To the extent either Party has the capability to measure the amount of traffic between Smart City Communications's switch and a BellSouth End Office and where such traffic exceeds or is forecasted to exceed a single DS1 of traffic per month, then the Parties shall install and retain direct end office trunking sufficient to handle such traffic volumes. Either Party will install additional capacity between such points when overflow traffic exceeds or is forecasted to exceed a single DS1 of traffic per month. In the case of one-way trunking, additional trunking shall only be required by the Party whose trunking has achieved the preceding usage threshold.
- 4.10.4.2.3 Mutual Agreement. The Parties may install direct end office trunking upon mutual agreement in the absence of conditions (1) or (2) above.
- 4.10.5 Transit Traffic Trunk Group
- 4.10.5.1 Transit Traffic trunks can either be two-way trunks or two (2) one-way trunks ordered by Smart City Communications to deliver and receive Transit Traffic. Establishing Transit Traffic trunks at BellSouth Access and Local Tandems provides IntraTandem Access to the third parties also interconnected at those tandems. Smart City Communications shall be responsible for all recurring and nonrecurring charges associated with Transit Traffic trunks and facilities.
- 4.10.5.2 Toll Free Traffic
- 4.10.5.2.1 If Smart City Communications chooses BellSouth to perform the Service Switching Point (SSP) Function (i.e., handle Toll Free database queries) from BellSouth's switches, all Smart City Communications originating Toll Free traffic will be routed over the Transit Traffic Trunk Group and shall be delivered using GR-394 format. Carrier Code "0110" and Circuit Code (to be determined for each LATA) shall be used for all such calls.
- 4.10.5.2.2 Smart City Communications may choose to perform its own Toll Free database queries from its switch. In such cases, Smart City Communications will determine the nature (local/intraLATA/interLATA) of the Toll Free call (local/IntraLATA/InterLATA) based on the response from the database. If the call is a BellSouth local or intraLATA Toll Free call, Smart City Communications will route the post-query local or IntraLATA converted ten (10)-digit local number to BellSouth over the local or intraLATA trunk group. If the call is a third party (ICO, IXC, CMRS or other CLEC) local or intraLATA Toll Free call, Smart City Communications will route the post-query local or intraLATA converted ten (10)-digit local number to BellSouth over the Transit Traffic Trunk Group and Smart

City Communications shall provide to BellSouth a Toll Free billing record when appropriate. If the query reveals the call is an interLATA Toll Free call, Smart City Communications will route the post-query interLATA Toll Free call (1) directly from its switch for carriers interconnected with its network or (2) over the Transit Traffic Trunk Group to carriers that are not directly connected to Smart City Communications's network but that are connected to BellSouth's Access Tandem.

- 4.10.5.2.3 All post-query Toll Free calls for which Smart City Communications performs the SSP function, if delivered to BellSouth, shall be delivered using GR-394 format for calls destined to IXCs, and GR-317 format for calls destined to end offices that directly subtend a BellSouth Access Tandem within the LATA.

## **5 Network Design And Management For Interconnection**

- 5.1 Network Management and Changes. The Parties will exchange toll-free maintenance contact numbers and escalation procedures. The Parties will provide public notice of network changes in accordance with applicable federal and state rules and regulations.
- 5.2 Interconnection Technical Standards. The interconnection of all networks will be based upon accepted industry/national guidelines for transmission standards and traffic blocking criteria. Interconnecting facilities shall conform, at a minimum, to the telecommunications industry standard of DS1 pursuant to Telcordia Standard No. GR-NWT-00499. Where Smart City Communications chooses to utilize SS7 signaling, also known as CCS7, SS7 connectivity is required between the Smart City Communications switch and the BellSouth STP. BellSouth will provide SS7 signaling using Common Channel Signaling Access Capability in accordance with the technical specifications set forth in the BellSouth Guidelines to Technical Publication, GR-905-Core. Facilities of each Party shall provide the necessary on-hook, off-hook answer and disconnect supervision and shall provide calling number ID (Calling Party Number) when technically feasible.
- 5.3 Network Management Controls. Both Parties will work cooperatively to apply sound network management principles by invoking appropriate network management controls (e.g., call gapping) to alleviate or prevent network congestion.

## **6 Forecasting for Trunk Provisioning**

- 6.1 Within six (6) months after execution of this Agreement, Smart City Communications shall provide an initial interconnection trunk group forecast for each LATA in which it plans to provide service within BellSouth's region. Upon receipt of Smart City Communications's forecast, the Parties shall conduct a joint planning meeting to develop a joint interconnection trunk group forecast. Each forecast provided under this Section shall be deemed Confidential Information under the General Terms and Conditions.

- 6.1.1 At a minimum, the forecast shall include the projected quantity of Transit Trunks, Smart City Communications-to-BellSouth one-way trunks (Smart City Communications Trunks), BellSouth-to-Smart City Communications one-way trunks (BellSouth Trunk Groups) and/or two-way interconnection trunks, if the Parties have agreed to interconnect using two-way trunking to transport the Parties' Local Traffic, ISP-Bound Traffic and IntraLATA Toll Traffic. The quantities shall be projected for a minimum of six (6) months and shall include an estimate of the current year plus the next two (2) years total forecasted quantities. The Parties shall mutually develop BellSouth Trunk Groups and/or two-way interconnection trunk forecast quantities.
- 6.1.2 All forecasts shall include, at a minimum, Access Carrier Terminal Location (ACTL), trunk group type (e.g., local/intraLATA toll, Transit, Operator Services, 911, etc.), A location/Z location (CLLI codes for Smart City Communications location and BellSouth location where the trunks shall terminate), interface type (e.g., DS1), Direction of Signaling, Trunk Group Number, if known, (commonly referred to as the 2-6 code) and forecasted trunks in service each year (cumulative).
- 6.2 Once initial interconnection trunk forecasts have been developed, Smart City Communications shall continue to provide interconnection trunk forecasts at mutually agreeable intervals. Smart City Communications shall use its best efforts to make the forecasts as accurate as possible based on reasonable engineering criteria. The Parties shall continue to develop Reciprocal Trunk Group and/or two-way interconnection trunk forecasts as described in Section 6.1.1 above.
- 6.3 The submission and development of interconnection trunk forecasts shall not replace the ordering process for local interconnection trunks. Each Party shall exercise its best efforts to provide the quantity of interconnection trunks mutually forecasted. However, the provision of the forecasted quantity of interconnection trunks is subject to trunk terminations and facility capacity existing at the time the trunk order is submitted. Furthermore, the receipt and development of trunk forecasts does not imply any liability for failure to perform if capacity (trunk terminations or facilities) is not available for use at the forecasted time.
- 6.4 Trunk Utilization
- 6.4.1 For the BellSouth Trunk Groups that are Final Trunk Groups (BellSouth Final Trunk Groups), BellSouth and Smart City Communications shall monitor traffic on each BellSouth Final Trunk Group that is ordered and installed. The Parties agree that the BellSouth Final Trunk Groups will be utilized at sixty percent (60%) of the time consistent busy hour utilization level within ninety (90) days of installation. The Parties agree that the BellSouth Final Trunk Groups will be utilized at eighty percent (80%) of the time consistent busy hour utilization level within one hundred eighty (180) days of installation. Any BellSouth Final Trunk Group not meeting the minimum thresholds set forth in this Section are defined as

“under-utilized” trunks. Subject to Section 6.4.2 below, BellSouth may disconnect any under-utilized BellSouth Final Trunk Groups and Smart City Communications shall refund to BellSouth the associated nonrecurring and recurring trunk and facility charges paid by BellSouth, if any.

6.4.2 BellSouth’s CISC will notify Smart City Communications of any under-utilized BellSouth Trunk Groups and the number of such trunk groups that BellSouth wishes to disconnect. BellSouth will provide supporting information either by email or facsimile to the designated Smart City Communications interface. Smart City Communications will provide concurrence with the disconnection in seven (7) business days or will provide specific information supporting why the trunks should not be disconnected. Such supporting information should include expected traffic volumes (including traffic volumes generated due to Local Number Portability) and the timeframes within which Smart City Communications expects to need such trunks. BellSouth’s CISC Project Manager and Circuit Capacity Manager (CCM) will discuss the information with Smart City Communications to determine if agreement can be reached on the number of BellSouth Final Trunk Groups to be removed. If no agreement can be reached, BellSouth will issue disconnect orders to Smart City Communications. The due date of these orders will be four (4) weeks after Smart City Communications was first notified in writing of the underutilization of the trunk groups.

6.4.3 To the extent that any interconnection trunk group is utilized at a time-consistent busy hour of eighty percent (80%) or greater, the Parties may review the trunk groups and, if necessary, shall negotiate in good faith for the installation of augmented facilities.

6.4.4 For the two-way trunk groups, BellSouth and Smart City Communications shall monitor traffic on each interconnection trunk group that is ordered and installed. The Parties agree that within ninety (90) days of the installation of the BellSouth two-way trunk or trunks, the trunks will be utilized at 60 percent (60%) of the time consistent busy hour utilization level. The Parties agree that within one hundred eighty (180) days of the installation of a trunk or trunks, the trunks will be utilized at eighty percent (80%) of the time consistent busy hour utilization level. Any trunk or trunks not meeting the minimum thresholds set forth in this Section are defined as “under-utilized” trunks. BellSouth will request the disconnection of any under-utilized two-way trunk(s) and Smart City Communications shall refund to BellSouth the associated nonrecurring and recurring trunk and facility charges paid by BellSouth, if any.

6.4.4.1 BellSouth’s CISC will notify Smart City Communications of any under-utilized two-way trunk groups and the number of trunks that BellSouth wishes to disconnect. BellSouth will provide supporting information either by email or facsimile to the designated Smart City Communications interface. Smart City Communications will provide concurrence with the disconnection in seven (7) business days or will provide specific information supporting why the two-way

trunks should not be disconnected. Such supporting information should include expected traffic volumes (including traffic volumes generated due to Local Number Portability) and the timeframes within which Smart City Communications expects to need such trunks. BellSouth's CISC Project Manager and CCM will discuss the information with Smart City Communications to determine if agreement can be reached on the number of trunks to be removed. If no agreement can be reached, Smart City Communications will issue disconnect orders to BellSouth. The due date of these orders will be four (4) weeks after Smart City Communications was first notified in writing of the under-utilization of the trunk groups.

6.4.4.2 To the extent that any interconnection trunk group is utilized at a time-consistent busy hour of eighty percent (80%) or greater, the Parties may review the trunk groups and, if necessary, shall negotiate in good faith for the installation of augmented facilities.

## **7 Local Dialing Parity**

7.1 BellSouth and Smart City Communications shall provide local and toll dialing parity, as defined in FCC rules and regulations, with no unreasonable dialing delays. Dialing parity shall be provided for all originating Telecommunications Services that require dialing to route a call.

## **8 Interconnection Compensation**

8.1 Compensation for Call Transport and Termination for Local Traffic, ISP-Bound Traffic and IntraLATA Toll Traffic

8.1.1 For the purposes of this Attachment and for intercarrier compensation for Local Traffic exchanged between the Parties pursuant to this Attachment, Local Traffic is defined as any telephone call that originates from one Party's customer located in one exchange and terminates to the other Party's customer in either the same exchange, or other local calling area associated with the originating calling party's exchange as defined and specified in Section A3 of BellSouth's GSST.

8.1.1.1 Additionally, Local Traffic includes any cross boundary, voice-to-voice intrastate, interLATA or interstate, interLATA calls established as a local call by the ruling regulatory body.

8.1.2 For purposes of this Attachment and for intercarrier compensation for ISP-Bound Traffic exchanged between the Parties, ISP-Bound Traffic is defined as calls to an information service provider or Internet Service Provider (ISP) that are dialed by using a local dialing pattern (seven (7) or ten (10) digits) by a calling party in one (1) exchange to an ISP server or modem in either the same exchange or other local calling area associated with the originating exchange as defined and specified in Section A3 of BellSouth's GSST. ISP-Bound Traffic is not Local Traffic

subject to reciprocal compensation, but instead is information access traffic subject to the FCC's jurisdiction.

- 8.1.3 Neither Party shall pay compensation to the other Party for per minute of use rate elements as set forth in Exhibit A associated with the Call Transport and Termination of Local Traffic or ISP-Bound Traffic.
- 8.1.4 The appropriate elemental rates set forth in Exhibit A shall apply for Transit Traffic as described in this Attachment and for MTA as described in this Attachment.
- 8.1.5 Neither Party shall represent Switched Access Traffic as Local Traffic or ISP-Bound Traffic for purposes of determining compensation for the call. If Smart City Communications delivers Switched Access Traffic to BellSouth for termination in violation of this Section, BellSouth shall charge Smart City Communications terminating switched access charges as set forth in BellSouth's Intrastate Access Services Tariff and/or BellSouth's FCC No. 1 Tariff, as appropriate. Additionally, such delivery of traffic shall constitute improper use of BellSouth facilities as set forth in Section 1.5.2 of Attachment 7 of this Agreement.
- 8.1.6 IntraLATA Toll Traffic is defined as all traffic, regardless of transport protocol method, that originates and terminates within a single LATA that is not Local Traffic or ISP-Bound traffic under this Attachment.
- 8.1.6.1 For terminating its intraLATA toll traffic on the other Party's network, the originating Party will pay the terminating Party BellSouth's current intrastate or interstate, whichever is appropriate, terminating switched access tariff rates as set forth in BellSouth's intrastate Access Services Tariffs and/or BellSouth's FCC No. 1 Tariff as filed and in effect with the FCC or appropriate Commission. The appropriate charges will be determined by the routing of the call. Additionally, if one (1) Party is the other Party's customer's presubscribed interexchange carrier or if one (1) Party's customer uses the other Party as an interexchange carrier on a 101XXXX basis, the originating party will charge the other Party the appropriate BellSouth originating switched access tariff rates as set forth in BellSouth's intrastate Access Services Tariff and/or BellSouth's FCC No. 1 Tariff as filed and in effect with the FCC or appropriate Commission.
- 8.1.7 If Smart City Communications assigns NPA/NXXs to specific BellSouth rate centers within the LATA and assigns numbers from those NPA/NXXs to Smart City Communications customer physically located outside of that LATA, BellSouth traffic originating from within the LATA where the NPA/NXXs are assigned and delivered to a Smart City Communications customer physically located outside of such LATA, shall not be deemed Local Traffic. Further, Smart City Communications agrees to identify such interLATA traffic to BellSouth and to compensate BellSouth for originating and transporting such interLATA traffic to Smart City Communications at BellSouth's FCC No. 1 Tariff rates.

8.2 If Smart City Communications does not identify such interLATA traffic to BellSouth, BellSouth will determine which whole Smart City Communications NPA/NXXs on which to charge the applicable rates for originating network access service as reflected in BellSouth's intrastate Access Services Tariff and/or BellSouth's FCC No. 1 Tariff.. BellSouth shall make appropriate billing adjustments if Smart City Communications can provide sufficient information for BellSouth to determine whether or not said traffic is Local or ISP-Bound Traffic.

8.3 Jurisdictional Reporting

8.3.1 Percent Local Use (PLU). Each Party shall report to the other a PLU factor. The application of the PLU will determine the amount of local or ISP-Bound minutes to be billed to the other Party. Each Party shall update its PLU on the first of January, April, July and October of the year and shall send it to the other Party to be received no later than thirty (30) days after the first of each such month based on local and ISP-Bound usage for the past three (3) months ending the last day of December, March, June and September, respectively. Requirements associated with PLU calculation and reporting shall be as set forth in BellSouth's Jurisdictional Factors Reporting Guide.

8.3.2 Percent Local Facility (PLF). Each Party shall report to the other a PLF factor. The application of the PLF will determine the portion of switched dedicated transport to be billed per the local jurisdiction rates. The PLF shall be applied to Multiplexing, Local Channel and Interoffice Channel Switched Dedicated Transport utilized in the provision of local interconnection trunks. Each Party shall update its PLF on the first of January, April, July and October of the year and shall send it to the other Party to be received no later than thirty (30) days after the first of each such month to be effective the first bill period the following month, respectively. Requirements associated with PLF calculation and reporting shall be as set forth in BellSouth's Jurisdictional Factors Reporting Guide.

8.3.3 Percent Interstate Usage (PIU). Each Party shall report to the other the projected PIU factors, including but not limited to PIU associated with facilities (PIUE) and Terminating PIU (TPIU) factors. The application of the PIU will determine the respective interstate traffic percentages to be billed at BellSouth's FCC No. 1 Tariff rates. All jurisdictional report requirements, rules and regulations for Interexchange Carriers specified in BellSouth's intrastate Access Services Tariff will apply to Smart City Communications. After interstate and intrastate traffic percentages have been determined by use of PIU procedures, the PLU and PLF factors will be used for application and billing of local traffic and facilities. The intrastate toll traffic shall be billed at BellSouth's intrastate Access Services Tariff rates. Each Party shall update its PIUs on the first of January, April, July and October of the year and shall send it to the other Party to be received no later than thirty (30) days after the first of each such month, for all services showing the percentages of use for the past three (3) months ending the last day of December, March, June and September. Additional requirements associated with PIU



calculations and reporting shall be as set forth in BellSouth's Jurisdictional Factors Reporting Guide.

- 8.3.4 Notwithstanding the provisions in Sections 8.3.1, 8.3.2, and 8.3.3 above, where BellSouth has message recording technology that identifies the jurisdiction of traffic terminated as defined in this Agreement, such information shall, at BellSouth's option, be utilized to determine the appropriate jurisdictional reporting factors (i.e., PLU, PIU, and/or PLF), in lieu of those provided by Smart City Communications. In the event that BellSouth opts to utilize its own data to determine jurisdictional reporting factors, BellSouth shall notify Smart City Communications at least fifteen (15) days prior to the beginning of the calendar quarter in which BellSouth will begin to utilize its own data.
- 8.3.5 Audits. On thirty (30) days written notice, Smart City Communications must provide BellSouth the ability and opportunity to conduct an annual audit to ensure the proper billing of traffic. Smart City Communications shall retain records of call detail for a minimum of nine (9) months from which the PLU, PLF and/or PIU can be ascertained. The audit shall be conducted during normal business hours at an office designated by Smart City Communications. Audit requests shall not be submitted more frequently than one (1) time per calendar year. Audits shall be performed by an independent auditor chosen by BellSouth. The audited factor (PLF, PLU and/or PIU) shall be adjusted based upon the audit results and shall apply to the usage for the audited period through the time period when the audit is completed, to the usage for the quarter prior to the audit period, and to the usage for the two (2) quarters following the completion of the audit. If, as a result of an audit, Smart City Communications is found to have overstated the PLF, PLU and/or PIU by twenty percentage points (20%) or more, Smart City Communications shall reimburse BellSouth for the cost of the audit.
- 8.4 Compensation for IntraLATA 8XX Traffic. Smart City Communications shall pay the appropriate switched access charges set forth in the BellSouth's intrastate Access Services tariff and/or BellSouth's FCC No. 1 Tariff. Smart City Communications will pay BellSouth the database query charge as set forth in the applicable BellSouth intrastate Access Services Tariff and/or BellSouth's FCC No. 1 Tariff. Smart City Communications will be responsible for any applicable Common Channel Signaling (SS7) charges.
- 8.4.1 Records for 8XX Billing. Where technically feasible, each Party will provide to the other Party the appropriate records, in accordance with industry standards, necessary for billing intraLATA 8XX providers. The records provided will be in a standard EMI format.
- 8.4.2 8XX Toll Free Dialing Ten Digit Screening Service (8XX TFD). BellSouth's provision of 8XX TFD to Smart City Communications requires interconnection from Smart City Communications to BellSouth's 8XX Signal Channel Point. Such interconnections shall be established pursuant to BellSouth's Common Channel

Signaling Interconnection Guidelines and Telcordia's CCS Network Interface Specification document, TR-TSV-000905. Smart City Communications shall establish SS7 interconnection at the BellSouth LSTPs serving the BellSouth 8XX Signal Channel Points that Smart City Communications desires to query. The terms and conditions for 8XX TFD are set out in the appropriate BellSouth Access Services Tariff.

## 8.5 Mutual Provision of Switched Access Service

8.5.1 Switched Access Traffic. Switched Access Traffic is described as telephone calls requiring local transmission or switching services for the purpose of the origination or termination of Telephone Toll Service. Switched Access Traffic includes, but is not limited to, the following types of traffic: Feature Group A, Feature Group B, Feature Group C, Feature Group D, toll free access (e.g., 8XX), 900 access and their successors. Additionally, any PSTN interexchange telecommunications traffic, regardless of transport protocol method, where the originating and terminating points, end-to-end points, are in different LATAs, or are in the same LATA and the Parties' Switched Access services are used for the origination or termination of the call, shall be considered Switched Access Traffic. Irrespective of transport protocol method or method of originating or terminating the call, a call that originates in one LATA and terminates in another LATA (i.e., the end-to-end points of the call) or a call in which the Parties' Switched Access Services are used for the origination or termination of the call, shall be considered Switched Access Traffic.

8.5.2 If a BellSouth end user chooses Smart City Communications as their presubscribed interexchange carrier, or if a BellSouth end user uses Smart City Communications as an interexchange carrier on a 101XXXX basis, BellSouth will charge Smart City Communications the appropriate BellSouth tariff charges for originating switched access services.

8.5.3 Where the originating Party delivers a call to the terminating Party over switched access facilities, the originating Party will pay the terminating Party terminating, switched access charges as set forth in BellSouth's intrastate Access Services Tariff and/or BellSouth's FCC No. 1 Tariff, as appropriate.

8.5.4 When Smart City Communications's end office switch provides an access service connection to or from an IXC by a direct trunk group to the IXC utilizing BellSouth facilities, each Party will provide its own access services to the IXC and bill on a multi-bill, multi-tariff meet-point basis. Each Party will bill its own access services rates to the IXC with the exception of the interconnection charge. The interconnection charge will be billed by Smart City Communications as the Party providing the end office function. Each party will use the Multiple Exchange Carrier Access Billing (MECAB) guidelines to establish Meet Point Billing for all applicable traffic. The Parties shall utilize a thirty (30) day billing period.

- 8.5.4.1 In cases where Smart City Communications has a unique hosted Revenue Accounting Office (RAO) code and Smart City Communications's end office subtends the BellSouth Access Tandem switch for receipt or delivery of switched access traffic and provides an access service connection to or from an IXC via BellSouth's Access Tandem switch, BellSouth, as the tandem company agrees to provide to Smart City Communications, as the End Office Company, as defined in MECAB, at no charge, all the switched access detail usage data, recorded at the access tandem, within no more than sixty (60) days after the recording date. Each Party will notify the other when it is not feasible to meet these requirements. As business requirements change, data reporting requirements may be modified as necessary.
- 8.5.5 BellSouth, as the tandem provider company, will retain for a minimum period of sixty (60) days, access message detail sufficient to recreate any data that is lost or damaged by the tandem provider company or any third party involved in processing or transporting data.
- 8.5.6 Smart City Communications shall not deliver switched access traffic to BellSouth for termination over any trunks and facilities other than Smart City Communications ordered switched access trunks and facilities.
- 8.6 Transit Traffic
- 8.6.1 BellSouth shall provide tandem switching and transport services for Smart City Communications's Transit Traffic. Rates for local Transit Traffic and ISP-Bound Transit Traffic shall be the applicable rate elements for Tandem Switching, Common Transport and Tandem Intermediary Charge as set forth in Exhibit A. Rates for Switched Access Transit Traffic shall be the applicable charges as set forth in BellSouth's intrastate Access Services Tariff and/or BellSouth's FCC No. 1 Tariff. Billing associated with all Transit Traffic shall be pursuant to MECAB guidelines. Traffic between Smart City Communications and Wireless Type 1 third parties or Wireless Type 2A third parties that do not engage in Meet Point Billing with BellSouth shall not be treated as Transit Traffic from a routing or billing perspective until such time as such traffic is identifiable as Transit Traffic.
- 8.6.2 The delivery of traffic that transits the BellSouth network is excluded from any BellSouth billing guarantees. BellSouth agrees to deliver Transit Traffic to the terminating carrier; provided, however, that Smart City Communications is solely responsible for negotiating and executing any appropriate contractual agreements with the terminating carrier for the exchange of Transit Traffic through the BellSouth network. BellSouth will not be liable for any compensation to the terminating carrier or to Smart City Communications. In the event that the terminating third party carrier imposes on BellSouth any charges or costs for the delivery of Transit Traffic, Smart City Communications shall reimburse BellSouth for such charges or costs.

- 8.7 For purposes of intercarrier compensation, BellSouth will not be responsible for any compensation associated with the exchange of traffic between Smart City Communications and a CLEC utilizing BellSouth switching. Where technically feasible, BellSouth will use commercially reasonable efforts to provide records to Smart City Communications to identify those CLECs utilizing BellSouth switching with whom Smart City Communications has exchanged traffic. Such traffic shall not be considered Transit Traffic from a routing or billing perspective, but instead will be considered as traffic exchanged solely between Smart City Communications and the CLEC utilizing BellSouth switching.
- 8.7.1 Smart City Communications is solely responsible for negotiating and executing any appropriate contractual agreements with the terminating carrier for the exchange of traffic with a CLEC utilizing BellSouth switching. BellSouth will not be liable for any compensation to the terminating carrier or to Smart City Communications. In the event that the terminating third party carrier imposes on BellSouth any charges or costs for the delivery of such traffic, Smart City Communications shall reimburse BellSouth for all such charges or costs.
- 8.8 Smart City Communications shall send all IntraLATA toll traffic to be terminated by an independent telephone company to the End User's IntraLATA toll provider and shall not send such traffic to BellSouth as Transit Traffic. IntraLATA toll traffic shall be any traffic that originates outside of the terminating independent telephone company's local calling area.

## **9 Ordering Charges**

- 9.1 The facilities purchased pursuant to this Attachment shall be ordered via the ASR process.
- 9.2 The rates, terms and conditions associated with submission and processing of ASRs are as set forth in BellSouth's FCC No. 1 Tariff, Section 5.

## **10 Basic 911 and E911 Interconnection**

- 10.1 Basic 911 and E911 provides a caller access to the applicable emergency service bureau by dialing 911.
- 10.2 Basic 911 Interconnection. BellSouth will provide to Smart City Communications a list consisting of each municipality that subscribes to Basic 911 service. The list will also provide, if known, the E911 conversion date for each municipality and, for network routing purposes, a ten (10) digit directory number representing the appropriate emergency answering position for each municipality subscribing to 911. Smart City Communications will be required to arrange to accept 911 calls from its end users in municipalities that subscribe to Basic 911 service and translate the 911 call to the appropriate ten (10) digit directory number as stated on the list provided by BellSouth. Smart City Communications will be required to route that call to the appropriate PSAP. When a municipality converts to E911

service, Smart City Communications will be required to begin using E911 procedures.

- 10.3 E911 Interconnection. Smart City Communications shall install a minimum of two (2) dedicated trunks originating from its SWC and terminating to the appropriate E911 tandem. The SWC must be in the same LATA as the E911 tandem. The dedicated trunks shall be, at a minimum, DS0 level trunks configured as part of a digital (one point five forty-four (1.544) Mb/s) interface (DS1 facility). The configuration shall use CAMA-type signaling with MF pulsing or SS7/ISUP signaling either of which shall deliver ANI with the voice portion of the call. If SS7/ISUP connectivity is used, Smart City Communications shall follow the procedures as set forth in Appendix A of the CLEC Users Guide to E911 for Facility Based Providers that is located on the BellSouth Interconnection Web site. If the user interface is digital, MF pulses as well as other AC signals shall be encoded per the u-255 Law convention. Smart City Communications will be required to provide BellSouth daily updates to the E911 database. Smart City Communications will be required to forward 911 calls to the appropriate E911 tandem along with ANI based upon the current E911 end office to tandem homing arrangement as provided by BellSouth. If the E911 tandem trunks are not available, Smart City Communications will be required to route the call to a designated seven (7) digit or ten (10) digit local number residing in the appropriate PSAP. This call will be transported over BellSouth's interoffice network and will not carry the ANI of the calling party. Smart City Communications shall be responsible for providing BellSouth with complete and accurate data for submission to the 911/E911 database for the purpose of providing 911/E911 to its end users.
- 10.4 Trunks and facilities for 911 Interconnection may be ordered by Smart City Communications from BellSouth pursuant to the terms and conditions set forth in this Attachment.
- 10.5 The detailed practices and procedures for 911/E911 interconnection are contained in the E911 Local Exchange Carrier Guide For Facility-Based Providers that is located on the BellSouth Interconnection Services Web site.

## **11 SS7 Network Interconnection**

- 11.1 SS7 Signaling. Both Parties will utilize LEC-to-LEC SS7 Signaling, where available, in conjunction with all traffic in order to enable interoperability of CLASS features and functions except for call return. SS7 signaling parameters will be provided, including but not limited to ANI, originating line information (OLI) calling company category and charge number. Privacy indicators will be honored, and the Parties will exchange Transactional Capabilities Application Part (TCAP) messages to facilitate SS7 based features between the respective networks. Neither Party shall alter the SS7 parameters, or be a party to altering such parameters, or knowingly pass SS7 parameters that have been altered in order

to circumvent appropriate interconnection charges. Nothing herein shall obligate or otherwise require BellSouth to send SS7 messages or call-related database queries to Smart City Communications's or any other third party's call-related database, unless otherwise agreed to by the Parties under a separate agreement.

- 11.2 Signaling Call Information. BellSouth and Smart City Communications will send and receive ten (10) digits for Local Traffic. Additionally, BellSouth and Smart City Communications will exchange the proper call information, (i.e., originated call company number and destination call company number, CIC, and OZZ) including all proper translations for routing between networks and any information necessary for billing.
- 11.3 SS7 Network Interconnection is the interconnection of Smart City Communications LSTP switches or Smart City Communications local or tandem switching systems with BellSouth STP switches. This interconnection provides connectivity that enables the exchange of SS7 messages among BellSouth switching systems and databases, Smart City Communications local or tandem switching systems, and other third party switching systems directly connected to the BellSouth SS7 network.
- 11.3.1 The connectivity provided by SS7 Network Interconnection shall fully support the functions of BellSouth switching systems and databases and Smart City Communications or other third party switching systems with A-link access to the BellSouth SS7 network.
- 11.3.2 If traffic is routed based on dialed or translated digits between a Smart City Communications local switching system and a BellSouth or other third party local switching system, either directly or via a BellSouth tandem switching system, then it is a requirement that the BellSouth SS7 network convey via SS7 Network Interconnection the TCAP messages that are necessary to provide Call Management services (i.e., Automatic Callback, Automatic Recall, and Screening List Editing) between the Smart City Communications LSTP switches and BellSouth or other third party local switch.
- 11.3.3 SS7 Network Interconnection shall provide:
- 11.3.3.1 Signaling Data Link functions, as specified in ANSI T1.111.2;
- 11.3.3.2 Signaling Link functions, as specified in ANSI T1.111.3; and
- 11.3.3.3 Signaling Network Management functions, as specified in ANSI T1.111.4.
- 11.3.4 SS7 Network Interconnection shall provide all functions of the SCCP necessary for Class 0 (basic connectionless) service as specified in ANSI T1.112. This includes GTT and SCCP Management procedures as specified in ANSI T1.112.4. Where the destination signaling point is a BellSouth switching system or DB, or is another third party local or tandem switching system directly connected to the

BellSouth SS7 network, SS7 Network Interconnection shall include final GTT of messages to the destination and SCCP Subsystem Management of the destination. Where the destination signaling point is a Smart City Communications local or tandem switching system, SS7 Network Interconnection shall include intermediate GTT of messages to a gateway pair of Smart City Communications LSTPs and shall not include SCCP Subsystem Management of the destination.

- 11.3.5 SS7 Network Interconnection shall provide all functions of the ISUP as specified in ANSI T1.113.
- 11.3.6 SS7 Network Interconnection shall provide all functions of the TCAP as specified in ANSI T1.114.
- 11.3.7 If Internetwork MRVT and SRVT become approved ANSI standards and available capabilities of BellSouth STPs, SS7 Network Interconnection may provide these functions of the OMAP.
- 11.4 Interface Requirements. The following SS7 Network Interconnection interface options are available to connect Smart City Communications or Smart City Communications-designated local or tandem switching systems or signaling transfer point switches to the BellSouth SS7 network:
  - 11.4.1 A-link interface from Smart City Communications local or tandem switching systems; and
  - 11.4.2 B-link interface from Smart City Communications STPs.
  - 11.4.3 The Signaling Point of Interconnection for each link shall be located at a cross-connect element in the central office where the BellSouth STP is located. There shall be a DS1 or higher rate transport interface at each of the signaling points of interconnection. Each signaling link shall appear as a DS0 channel within the DS1 or higher rate interface.
  - 11.4.4 BellSouth shall provide intraoffice diversity between the Signaling Point of Interconnection and the BellSouth STP, so that no single failure of intraoffice facilities or equipment shall cause the failure of both B-links in a layer connecting to a BellSouth STP.
  - 11.4.5 The protocol interface requirements for SS7 Network Interconnection include the MTP, ISUP, SCCP, and TCAP. These protocol interfaces shall conform to the applicable industry standard technical references.
  - 11.4.6 BellSouth shall set message screening parameters to accept messages from Smart City Communications local or tandem switching systems destined to any signaling point in the BellSouth SS7 network with which the Smart City Communications switching system has a valid signaling relationship.

- 11.5 Rates. The Parties shall institute a “bill and keep” compensation plan under which neither Party will charge the other Party for ISUP CCS7 signaling messages associated with Local Traffic. The portion of ISUP CCS7 signaling messages utilized for Local Traffic, which is subject to bill and keep in accordance with this section, shall be determined based upon the application of the applicable signaling factors set forth in BellSouth’s Jurisdictional Factors Reporting Guide. All other CCS7 signaling messages associated with Local Traffic will be billed at the rates set forth in Exhibit A. In addition, CCS7 facility charges, including charges for signaling ports and signaling links, utilized for Local Traffic will be billed at the rates set forth in Exhibit A. CCS7 signaling messages, signaling ports, and signaling links associated with interstate calls and with intrastate non-local calls, shall be billed in accordance with the applicable BellSouth intrastate Access Services Tariff and BellSouth’s FCC No. 1 Tariff for switched access services.



Exhibit B

# Basic Architecture

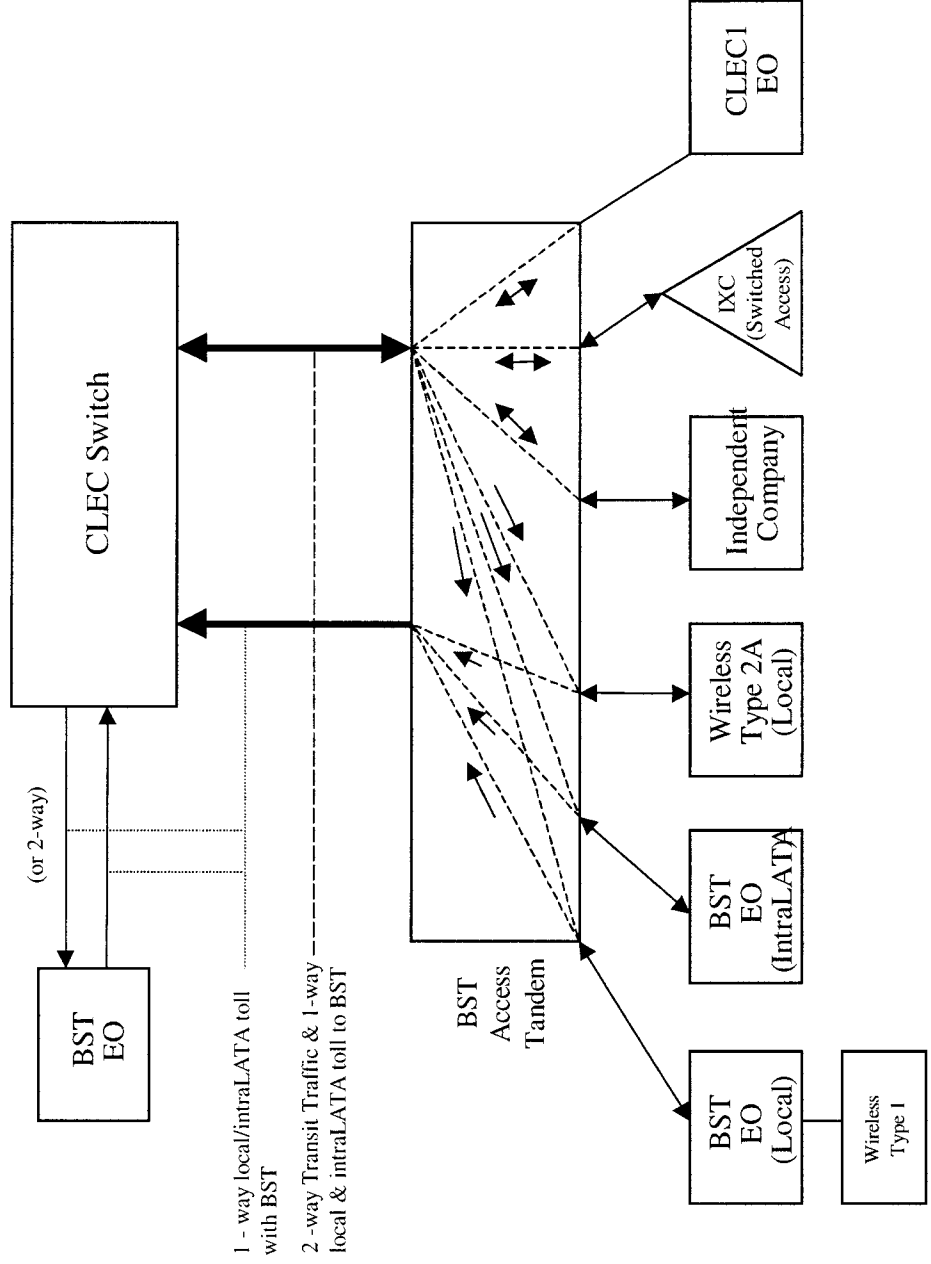

Exhibit C

# One-Way Architecture

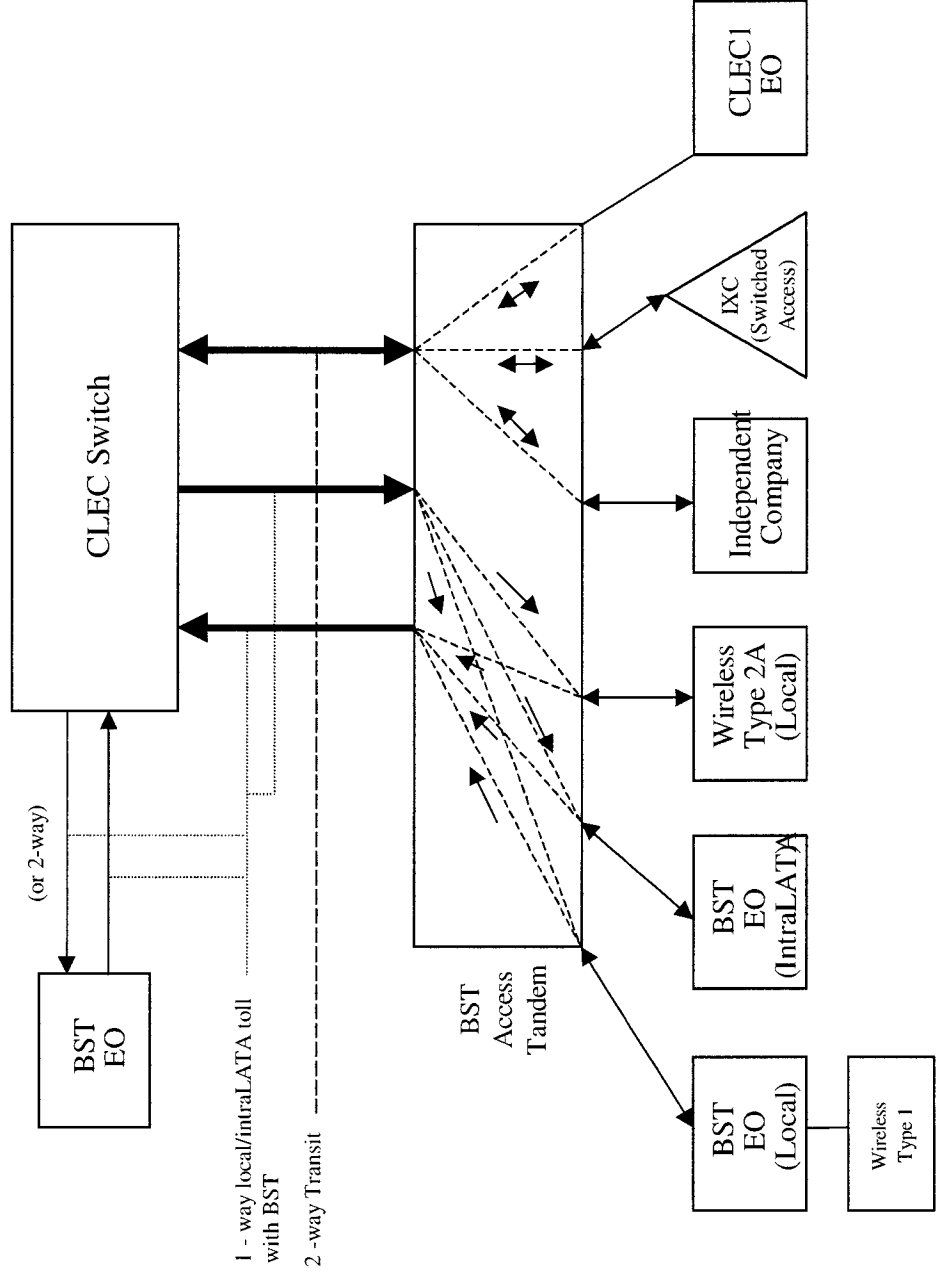

Exhibit D

# Two-Way Architecture

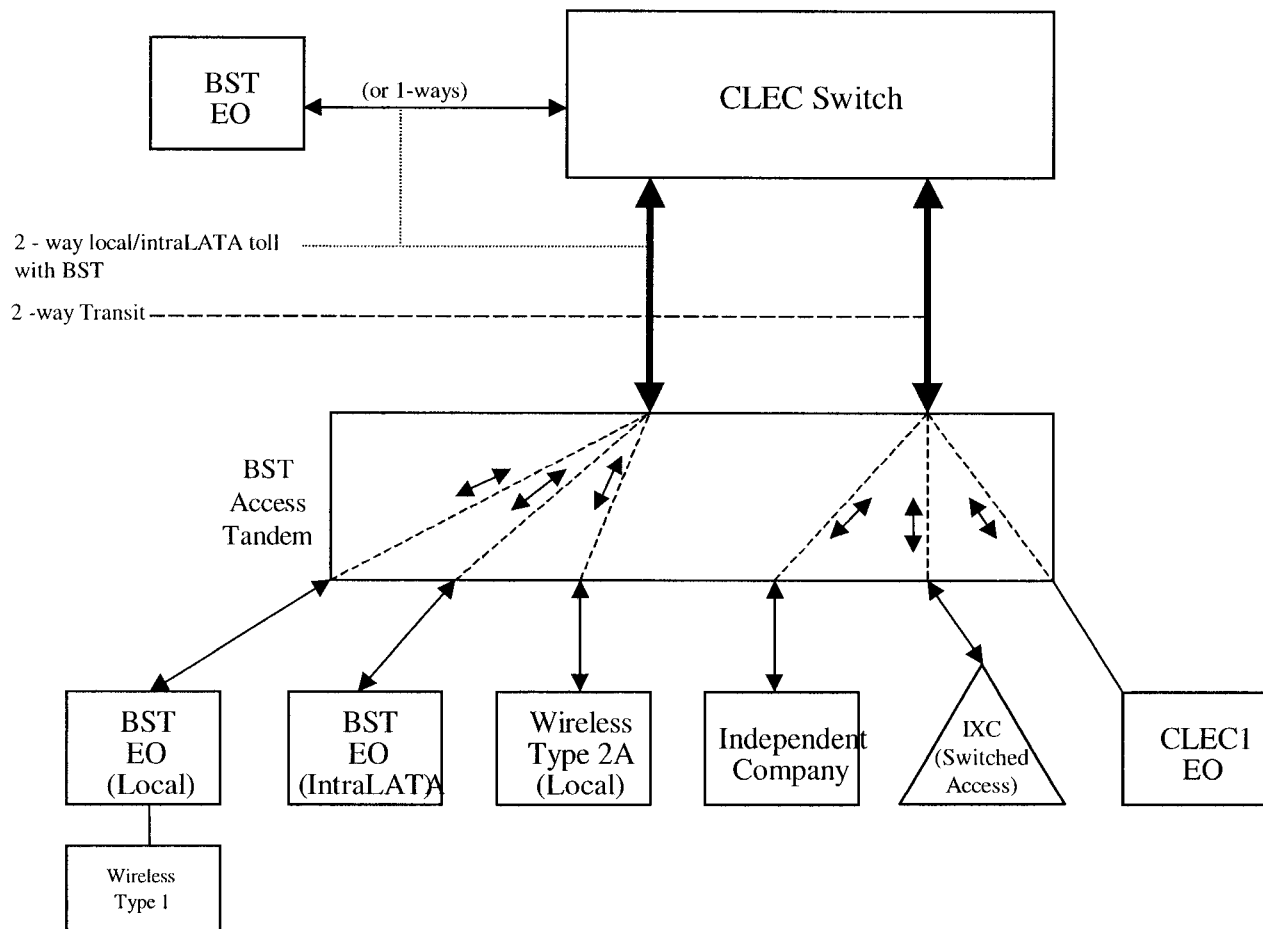
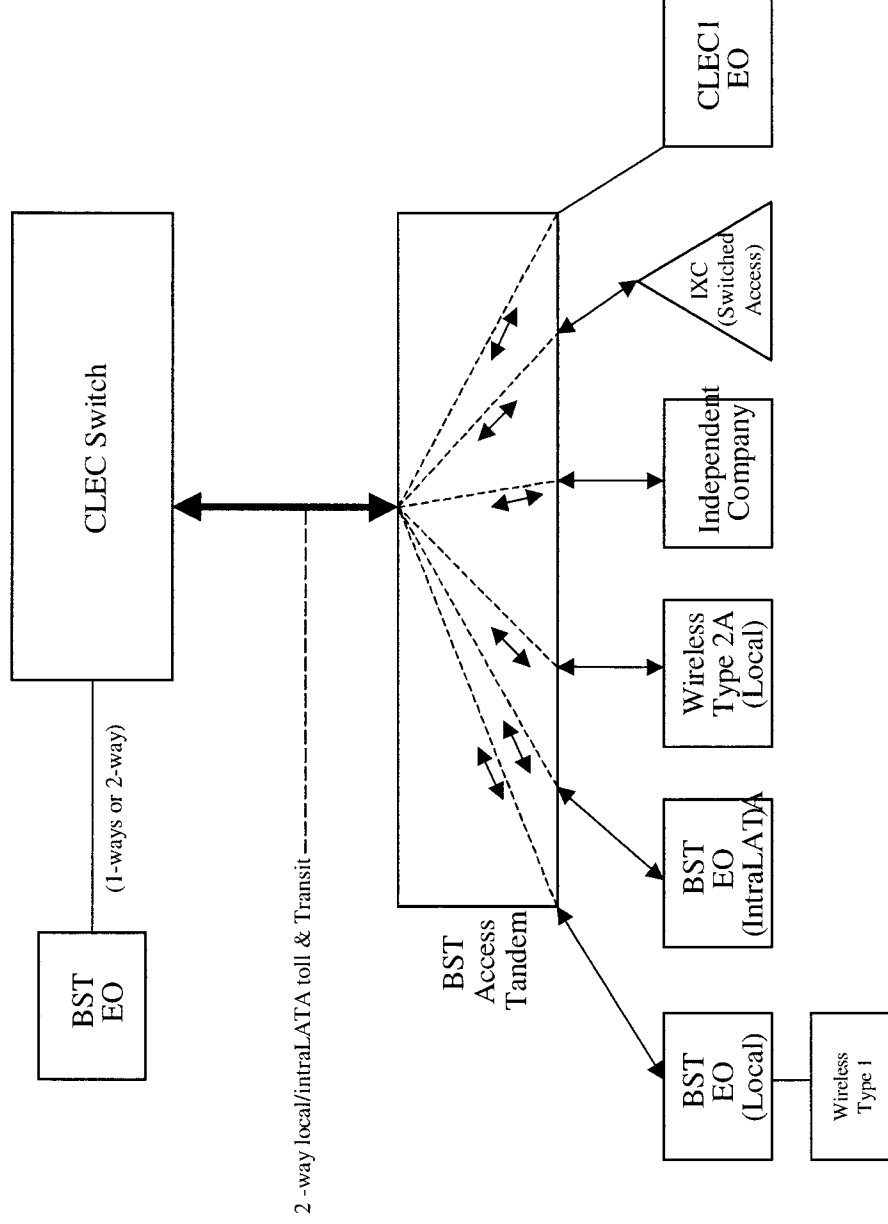

Exhibit E

# Supergroup Architecture



LOCAL INTERCONNECTION - Florida											Att: 3 Exh: A											
CATEGORY	RATE ELEMENTS	Interim	Zone	BCS	USOC	RATES(\$)				Svc Order Submitted Elec per LSR	Svc Order Submitted Manually per LSR	Incremental Charge - Manual Svc Order vs. Electronic-1st	Incremental Charge - Manual Svc Order vs. Electronic-Add'l	Incremental Charge - Manual Svc Order vs. Electronic-Disc 1st	Incremental Charge - Manual Svc Order vs. Electronic-Disc Add'l							
						Rec	Nonrecurring		Nonrecurring Disconnect							OSS Rates(\$)						
							First	Add'l	First							Add'l	SOMEc	SOMAN	SOMAN	SOMAN	SOMAN	SOMAN
<b>LOCAL INTERCONNECTION (CALL TRANSPORT AND TERMINATION)</b>																						
NOTE: "bk" beside a rate indicates that the Parties have agreed to bill and keep for that element pursuant to the terms and conditions in Attachment 3.																						
<b>TANDEM SWITCHING</b>																						
	Tandem Switching Function Per MOU					0.0006019bk																
	Multiple Tandem Switching, per MOU (applies to initial tandem only)					0.0006019																
	Tandem Intermediary Charge, per MOU*					0.0025																
* This charge is applicable only to transit traffic and is applied in addition to applicable switching and/or interconnection charges.																						
<b>TRUNK CHARGE</b>																						
	Installation Trunk Side Service - per DS0			OHD	TPP6X		21.73	8.19														
	Installation Trunk Side Service - per DS0			OHD	TPP9X		21.73	8.19														
	Dedicated End Office Trunk Port Service-per DS0**			OHD	TDEOP	0.00																
	Dedicated End Office Trunk Port Service-per DS1**			OH1 OH1MS	TDE1P	0.00																
	Dedicated Tandem Trunk Port Service-per DS0**			OHD	TDWOP	0.00																
	Dedicated Tandem Trunk Port Service-per DS1**			OH1 OH1MS	TDW1P	0.00																
** This rate element is recovered on a per MOU basis and is included in the End Office Switching and Tandem Switching, per MOU rate elements																						
<b>COMMON TRANSPORT (Shared)</b>																						
	Common Transport - Per Mile, Per MOU					0.0000035bk																
	Common Transport - Facilities Termination Per MOU					0.0004372bk																
<b>LOCAL INTERCONNECTION (DEDICATED TRANSPORT)</b>																						
<b>INTEROFFICE CHANNEL - DEDICATED TRANSPORT</b>																						
	Interoffice Channel - Dedicated Transport - 2-Wire Voice Grade - Per Mile per month			OHM	1L5NF	0.0091																
	Interoffice Channel - Dedicated Transport - 2-Wire Voice Grade - Facility Termination per month			OHM	1L5NF	25.32	47.35	31.78	18.31	7.03												
	Interoffice Channel - Dedicated Transport - 56 kbps - per mile per month			OHM	1L5NK	0.0091																
	Interoffice Channel - Dedicated Transport - 56 kbps - Facility Termination per month			OHM	1L5NK	18.44	47.35	31.78	18.31	7.03												
	Interoffice Channel - Dedicated Transport - 64 kbps - per mile per month			OHM	1L5NK	0.0091																
	Interoffice Channel - Dedicated Transport - 64 kbps - Facility Termination per month			OHM	1L5NK	18.44	47.35	31.78	18.31	7.03												
	Interoffice Channel - Dedicated Channel - DS1 - Per Mile per month			OH1, OH1MS	1L5NL	0.1856																
	Interoffice Channel - Dedicated Transport - DS1 - Facility Termination per month			OH1, OH1MS	1L5NL	88.44	105.54	98.47	21.47	19.05												
	Interoffice Channel - Dedicated Transport - DS3 - Per Mile per month			OH3, OH3MS	1L5NM	3.87																
	Interoffice Channel - Dedicated Transport - DS3 - Facility Termination per month			OH3, OH3MS	1L5NM	1,071.00	335.46	219.28	72.03	70.56												
<b>LOCAL CHANNEL - DEDICATED TRANSPORT</b>																						
	Local Channel - Dedicated - 2-Wire Voice Grade per month			OHM	TEFV2	19.66	265.84	46.97	37.63	4.00												
	Local Channel - Dedicated - 4-Wire Voice Grade per month			OHM	TEFV4	20.45	266.54	47.67	44.22	5.33												
	Local Channel - Dedicated - DS1 per month			OH1	TEFHG	36.49	216.65	183.54	24.30	16.95												
	Local Channel - Dedicated - DS3 Facility Termination per month			OH3	TEFHJ	531.91	556.37	343.01	139.13	96.84												
<b>LOCAL INTERCONNECTION MID-SPAN MEET</b>																						
	Local Channel - Dedicated - DS1 per month			OH1MS	TEFHG	0.00	0.00															
	Local Channel - Dedicated - DS3 per month			OH3MS	TEFHJ	0.00	0.00															
<b>MULTIPLEXERS</b>																						
	Channelization - DS1 to DS0 Channel System			OH1, OH1MS	SATN1	146.77	101.42	71.62	11.09	10.49												
	DS3 to DS1 Channel System per month			OH3, OH3MS	SATNS	211.19	199.28	118.64	40.34	39.07												
	DS3 Interface Unit (DS1 COC) per month			OH1, OH1MS	SATCO	13.76	10.07	7.08														
Notes: If no rate is identified in the contract, the rates, terms, and conditions for the specific service or function will be as set forth in applicable BellSouth tariff.																						
<b>SIGNALING (CCS7)</b>																						
NOTE: "bk" beside a rate indicates that the parties have agreed to bill and keep for that element pursuant to the terms and conditions in Attachment 3.																						
	CCS7 Signaling Termination, Per STP Port			UDB	PT8SX	135.05																
	CCS7 Signaling Usage, Per TCAP Message					0.0000607																
	CCS7 Signaling Connection, Per DS1 level link (A link)			UDB	TPP6A	17.93	43.57	43.57	18.31	18.31												
	CCS7 Signaling Connection, Per DS3 level link (A link)			UDB	TPP9A	17.93	43.57	43.57	18.31	18.31												
	CCS7 Signaling Connection, Per DS1 level link (B link) (also known as D link)			UDB	TPP6B	17.93	43.57	43.57	18.31	18.31												

LOCAL INTERCONNECTION - Florida											Att: 3 Exh: A				
CATEGORY	RATE ELEMENTS	Interim	Zone	BCS	USOC	RATES(\$)				Svc Order Submitted Elec per LSR	Svc Order Submitted Manually per LSR	Incremental Charge - Manual Svc Order vs. Electronic-1st	Incremental Charge - Manual Svc Order vs. Electronic-Add'l	Incremental Charge - Manual Svc Order vs. Electronic-Disc 1st	Incremental Charge - Manual Svc Order vs. Electronic-Disc Add'l
						Rec	Nonrecurring		Nonrecurring Disconnect						
							First	Add'l	First	Add'l	SOMEc	SOMAN	SOMAN	SOMAN	SOMAN
	CCS7 Signaling Connection, Per DS3 level link (B link) (also known as D link)			UDB	TPP9B	17.93	43.57	43.57	18.31	18.31					
	CCS7 Signaling Usage, Per ISUP Message					0.0000152bk									
	CCS7 Signaling Usage Surrogate, per link per LATA			UDB	STU56	694.32bk									
	CCS7 Signaling Point Code, per Originating Point Code Establishment or Change, per STP affected			UDB	CCAPO		46.03	46.03	46.03	46.03					
	CCS7 Signaling Point Code, per Destination Point Code Establishment or Change, Per Stp Affected			UDB	CCAPD										
	CCS7 Signaling Connection, Switched access service, interface groups, transmission paths 6 DS1 level path with bit stream signaling			UDB	TPP6X	17.93	43.57	43.57	18.31	18.31					
	CCS7 Signaling Connection, Switched access service, interface groups, transmission paths 9 DS3 level path with bit stream signaling			UDB	TPP9X	17.93	43.57	43.57	18.31	18.31					

**Attachment 4**  
**BellSouth Collocation**

**Table of Contents**

**1. Scope of Attachment .....3**

**2. Optional Reports .....6**

**3. Collocation Options.....7**

**4. Occupancy ..... 13**

**5. Use of Collocation Space ..... 15**

**6. Ordering and Preparation of Collocation Space.....23**

**7. Construction and Provisioning .....27**

**8. Rates and Charges ..... 31**

**9. Insurance ..... 38**

**10. Mechanics Lien..... 40**

**11. Inspections..... 40**

**12. Security and Safety Requirements ..... 40**

**13. Destruction of Collocation Space.....43**

**14. Eminent Domain ..... 44**

**15. Nonexclusivity ..... 44**

**Environmental & Safety Principles.....Exhibit A**

**Rates..... Exhibit B**



## BELLSOUTH COLLOCATION

### 1. Scope of Attachment

#### 1.1 BellSouth Premises

1.1.1 The rates, terms and conditions contained within this Attachment shall only apply when Smart City Communications is physically collocated as a sole occupant or as a Host within a BellSouth Premises pursuant to this Attachment. BellSouth Premises, as defined in this Attachment includes BellSouth Central Offices, and Remote Terminals (hereinafter “BellSouth Premises”). This Attachment is applicable to BellSouth Premises owned or leased by BellSouth. Where not specified, the language in this Attachment applies to both Central Office and Remote Site Collocation.

1.1.2 Third Party Property. If the BellSouth Premises, or the property on which it is located, is leased by BellSouth from a third party or otherwise controlled by a third party, special considerations and intervals may apply in addition to the terms and conditions of this Attachment. Additionally, where BellSouth notifies Smart City Communications that BellSouth’s agreement with a third party does not grant BellSouth the ability to provide access and use rights to others, upon Smart City Communications’s request, BellSouth will use commercially reasonable efforts to obtain the owner’s consent and to otherwise secure such rights for Smart City Communications. Smart City Communications agrees to reimburse BellSouth for all costs incurred by BellSouth in obtaining such rights for Smart City Communications. In cases where a third party agreement does not grant BellSouth the right to provide access and use rights to others as contemplated by this Attachment and BellSouth, is unable to secure such access and use rights for Smart City Communications, Smart City Communications shall be responsible for obtaining such permission to access and use such property. BellSouth shall cooperate with Smart City Communications in obtaining such permission.

#### 1.2 Right to Occupy

1.2.1 BellSouth shall offer to Smart City Communications collocation on rates, terms and conditions that are just, reasonable, nondiscriminatory and consistent with the rules of the FCC. Subject to the rates, terms and conditions of this Attachment, where space is available and it is technically feasible, BellSouth will allow Smart City Communications to occupy a certain area designated by BellSouth within a BellSouth Premises, or on BellSouth property upon which the BellSouth Premises is located, of a size which is specified by Smart City Communications and agreed to by BellSouth (hereinafter “Collocation Space”). Except as otherwise specified, any references to Collocation Space shall be for physical collocation. The necessary rates, terms and conditions for a premises as defined by the FCC, other than BellSouth Premises, shall be negotiated upon reasonable request for collocation at such premises.

1.2.2 Neither BellSouth nor any of BellSouth’s affiliates may reserve space for future use on more preferential terms than those set forth in this Attachment.

- 1.2.2.1 In all states other than Florida, the size specified by Smart City Communications may contemplate a request for space sufficient to accommodate Smart City Communications's growth within a twenty-four (24) month period.
- 1.2.2.2 In the state of Florida, the size specified by Smart City Communications may contemplate a request for space sufficient to accommodate Smart City Communications's growth within an eighteen (18) month period.
- 1.3 Space Allocation. BellSouth shall assign Smart City Communications Collocation Space that utilizes existing infrastructure (e.g., heating, ventilation, air conditioning (HVAC), lighting and available power), if such space is available for collocation. Otherwise, BellSouth shall attempt to accommodate Smart City Communications's requested space preferences, if any, including the provision of contiguous space for any subsequent request for collocation. In allocating Collocation Space, BellSouth shall not materially increase Smart City Communications's cost or materially delay Smart City Communications's occupation and use of the Collocation Space, assign Collocation Space that will impair the quality of service or otherwise limit the service Smart City Communications wishes to offer, reduce unreasonably the total space available for physical collocation or preclude reasonable physical collocation within the BellSouth Premises. Space shall not be available for collocation if it is: (a) physically occupied by non-obsolete equipment; (b) assigned to another collocated telecommunications carrier; (c) used to provide physical access to occupied space; (d) used to enable technicians to work on equipment located within occupied space; (e) properly reserved for future use, either by BellSouth or another collocated telecommunications carrier; or (f) essential for the administration and proper functioning of the BellSouth Premises. BellSouth may segregate Collocation Space and require separate entrances for collocated telecommunications carriers to access their Collocation Space, pursuant to FCC Rules.
- 1.4 Transfer of Collocation Space
- 1.4.1 Smart City Communications shall be allowed to transfer Collocation Space to another CLEC under the following conditions: (1) the BellSouth Premises is not at or near space exhaustion; (2) the transfer of space shall be contingent upon BellSouth's approval, which will not be unreasonably withheld; (3) Smart City Communications has no unpaid, undisputed collocation charges; and (4) the transfer of the Collocation Space is in conjunction with Smart City Communications's sale of all or substantially all, of the in-place collocation equipment to the same CLEC.
- 1.4.2 The responsibilities of Smart City Communications shall include: (1) submitting a letter of authorization to BellSouth for the transfer; (2) entering into a transfer agreement with BellSouth and the acquiring CLEC; and (3) returning all Security Access Devices to BellSouth. The responsibilities of the acquiring CLEC shall include: (1) submitting an application to BellSouth for the transfer of the Collocation Space; (2) satisfying all requirements of its interconnection

agreement with BellSouth; (3) submitting a letter to BellSouth for the assumption of services; and (4) entering into a transfer agreement with BellSouth and Smart City Communications.

- 1.4.3 In conjunction with a transfer of Collocation Space, any services associated with the Collocation Space shall be transferred pursuant to separately negotiated rates, terms and conditions.
- 1.5 Space Reclamation
- 1.5.1 In the event of space exhaust within a BellSouth Premises, BellSouth may include in its documentation for the Petition for Waiver filed with the Commission, any unutilized space in the BellSouth Premises. Smart City Communications will be responsible for the justification of unutilized space within its Collocation Space, if the Commission requires such justification.
- 1.5.2 BellSouth may reclaim unused Collocation Space when a BellSouth Premises is at, or near, space exhaustion and Smart City Communications cannot demonstrate that Smart City Communications will utilize the Collocation Space in the time frames set forth below in Section 1.5.3. In the event of space exhaust or near exhaust within a BellSouth Premises, BellSouth will provide written notice to Smart City Communications requesting that Smart City Communications release non-utilized Collocation Space to BellSouth, when one hundred percent (100%) of the Collocation Space in Smart City Communications's collocation arrangement is not being utilized.
- 1.5.3 Within twenty (20) days of receipt of written notification from BellSouth, Smart City Communications shall either: (1) return the non-utilized Collocation Space to BellSouth in which case Smart City Communications shall be relieved of all obligations for charges associated with that portion of the Collocation Space applicable from the date the Collocation Space is returned to BellSouth; or (2) for all states, with the exception of Florida, provide BellSouth with information demonstrating that the Collocation Space will be utilized within twenty-four (24) months from the date Smart City Communications accepted the Collocation Space (Acceptance Date) from BellSouth. For Florida, Smart City Communications shall provide information to BellSouth demonstrating that the Collocation Space will be utilized within eighteen (18) months from the Acceptance Date.
- 1.5.4 Disputes concerning BellSouth's claim of space exhaust, or near exhaust, or Smart City Communications's refusal to return requested Collocation Space should be resolved by BellSouth and Smart City Communications pursuant to the dispute resolution language contained in the General Terms and Conditions.
- 1.6 Use of Space. Smart City Communications may only place in the Collocation Space equipment necessary for interconnection with BellSouth's services/facilities or for accessing BellSouth's unbundled network elements for the provision of Telecommunications Services, as specifically set forth in this Agreement. The Collocation Space assigned to Smart City Communications may

not be used for any purposes other than as specifically described herein, including, but not limited to office space or a place of reporting for Smart City Communications's employees or certified suppliers.

- 1.7 Rates and Charges. Smart City Communications agrees to pay the rates and charges identified in Exhibit B.
- 1.8 Due Dates. If any due date contained in this Attachment falls on a weekend or a national holiday, then the due date will be the next business day thereafter. For intervals of ten (10) days or less, national holidays will be excluded. For purposes of this Attachment, national holidays include the following: New Year's Day, Martin Luther King, Jr. Day, President's Day (Washington's Birthday), Memorial Day, Independence Day, Labor Day, Columbus Day, Veteran's Day, Thanksgiving Day and Christmas Day.
- 1.9 Compliance. Subject to Section 24 of the General Terms and Conditions of this Agreement, the Parties agree to comply with all applicable federal, state, county, local and administrative laws, rules, ordinances, regulations and codes in the performance of their obligations hereunder.

## **2 Optional Reports**

- 2.1 Space Availability Report. Upon request from Smart City Communications and at Smart City Communications's expense, BellSouth will provide a written report (Space Availability Report) describing in detail the space that is currently available for collocation at a particular BellSouth Premises. This report will include the amount of Collocation Space available at the BellSouth Premises requested, the number of collocators present at the BellSouth Premises, any modifications in the use of the space since the last report on the BellSouth Premises requested and the measures BellSouth is taking to make additional space available for collocation arrangements. A Space Availability Report does not reserve space at the BellSouth Premises for which the Space Availability Report was requested by Smart City Communications.
- 2.1.1 The request from Smart City Communications for a Space Availability Report must be in writing and include the BellSouth Premises street address, as identified in the LERG, and the CLLI code for the BellSouth Premises requested. CLLI code information is located in the NECA Tariff FCC No. 4.
- 2.1.2 BellSouth will respond to a request for a Space Availability Report for a particular BellSouth Premises within ten (10) days of the receipt of such request.
- 2.1.3 BellSouth will use commercially reasonable efforts to respond in ten (10) days to a Space Availability Report request when the request includes from two (2) to five (5) BellSouth Premises within the same state. The response time for Space Availability Report requests of more than five (5) BellSouth Premises, whether the request is for the same state or for two (2) or more states within the BellSouth Region, shall be negotiated between the Parties.
- 2.2 Remote Terminal Information. Upon request, BellSouth will provide Smart City

Communications with the following information concerning BellSouth's remote terminals: (i) the address of the remote terminal; (ii) the CLLI code of the remote terminal; (iii) the carrier serving area of the remote terminal; (iv) the designation of which remote terminals subtend a particular central office; and (v) the number and address of customers that are served by a particular remote terminal.

- 2.2.1 BellSouth will provide this information within thirty (30) days of a Smart City Communications request subject to the following conditions: (i) the information will only be provided on a CD in the same format in which it appears in BellSouth's systems; and (ii) the information will only be provided for each serving wire center designated by Smart City Communications, up to a maximum of thirty (30) wire centers per Smart City Communications request per month per state. BellSouth will bill the nonrecurring charge pursuant to the rates in Exhibit B at the time BellSouth sends the CD.

### **3 Collocation Options**

- 3.1 Cageless Collocation. BellSouth shall allow Smart City Communications to collocate Smart City Communications's equipment and facilities without requiring the construction of a cage or similar structure. BellSouth shall allow Smart City Communications to have direct access to Smart City Communications's equipment and facilities in accordance with Section 5.1.2 below. BellSouth shall make cageless collocation available in single bay increments. Except where Smart City Communications's equipment requires special technical considerations (e.g., special cable racking or isolated ground plane), BellSouth shall assign cageless Collocation Space in conventional equipment rack lineups where feasible. For equipment requiring special technical considerations, Smart City Communications must provide the equipment layout, including spatial dimensions for such equipment pursuant to generic requirements contained in Telcordia GR-63-Core, and shall be responsible for compliance with all special technical requirements associated with such equipment.
- 3.2 Caged Collocation
- 3.2.1 BellSouth will make caged Collocation Space in Central Offices available in fifty (50) square foot increments. At Smart City Communications's option and expense, Smart City Communications will arrange with a Supplier certified by BellSouth (BellSouth Certified Supplier) to construct a collocation arrangement enclosure in accordance with BellSouth's specifications for a wire mesh enclosure prior to starting equipment installation. Where local building codes require enclosure specifications more stringent than BellSouth's wire mesh enclosure specifications, Smart City Communications and Smart City Communications's BellSouth Certified Supplier must comply with the more stringent local building code requirements. Smart City Communications's BellSouth Certified Supplier shall be responsible for filing and obtaining any and all necessary permits and/or licenses for such construction. BellSouth or BellSouth's designated agent or contractor shall provide, at Smart City Communications's expense, documentation, which may include existing building architectural drawings,

enclosure drawings, specifications, etc., necessary for Smart City Communications's BellSouth Certified Supplier to obtain all necessary permits and/or other licenses. Smart City Communications's BellSouth Certified Supplier shall bill Smart City Communications directly for all work performed for Smart City Communications. BellSouth shall have no liability for, nor responsibility to pay, such charges imposed by Smart City Communications's BellSouth Certified Supplier. Smart City Communications must provide the local BellSouth Central Office Building Contact with two (2) Access Keys that will allow entry into the locked enclosure. Except in the case of an emergency, BellSouth will not access Smart City Communications's locked enclosure prior to notifying Smart City Communications at least forty-eight (48) hours or two (2) business days, whichever is greater, before access to Smart City Communications's Collocation Space is required. Upon request, BellSouth shall construct the enclosure for Smart City Communications.

- 3.2.2 In the event Smart City Communications's BellSouth Certified Supplier will construct the collocation arrangement enclosure, BellSouth may elect to review Smart City Communications's plans and specifications, prior to allowing the construction to start, to ensure compliance with BellSouth's wire mesh enclosure specifications. BellSouth will notify Smart City Communications of its desire to conduct this review in BellSouth's Application Response, as defined herein, to Smart City Communications's Initial Application. If Smart City Communications's Initial Application does not indicate its desire to construct its own enclosure and Smart City Communications subsequently decides to construct its own enclosure prior to BellSouth's Application Response, then Smart City Communications will resubmit its Initial Application, indicating its desire to construct its own enclosure. If Smart City Communications subsequently decides to construct its own enclosure after the bona fide firm order (hereinafter "BFFO") has been accepted by BellSouth, Smart City Communications will submit a Subsequent Application, as defined in Section 6.2 below. If BellSouth elects to review Smart City Communications's plans and specifications, then BellSouth will provide notification to Smart City Communications within ten (10) days after the Initial Application BFFO date or, if a Subsequent Application is submitted as set forth in the preceding sentence, then the Subsequent Application BFFO date. BellSouth shall complete its review within fifteen (15) days after BellSouth's receipt of Smart City Communications's plans and specifications. Regardless of whether or not BellSouth elects to review Smart City Communications's plans and specifications, BellSouth reserves the right to inspect the enclosure after construction has been completed to ensure that it is constructed according to Smart City Communications's submitted plans and specifications and/or BellSouth's wire mesh enclosure specifications, as applicable. If BellSouth decides to inspect the constructed Collocation Space, BellSouth will complete its inspection within fifteen (15) days after receipt of Smart City Communications's written notification that the enclosure has been completed. Within seven (7) days after BellSouth has completed its inspection of Smart City Communications's caged Collocation Space, BellSouth shall require Smart City Communications, at

Smart City Communications's expense, to remove or correct any structure that does not meet Smart City Communications's plans and specifications or BellSouth's wire mesh enclosure specifications, as applicable.

3.3 Shared Caged Collocation

3.3.1 Smart City Communications may allow other telecommunications carriers to share Smart City Communications's caged Collocation Space, pursuant to the terms and conditions agreed to by Smart City Communications (Host) and the other telecommunications carriers (Guests) contained in this Section, except where the BellSouth Premises is located within a leased space and BellSouth is prohibited by said lease from offering such an option to Smart City Communications. BellSouth shall be notified in writing by Smart City Communications upon the execution of any agreement between the Host and its Guest(s) prior to the submission of an application. Further, such notification shall include the name of the Guest(s), the term of the agreement, and a certification by Smart City Communications that said agreement imposes upon the Guest(s) the same terms and conditions for Collocation Space as set forth in this Attachment between BellSouth and Smart City Communications. The term of the agreement between the Host and its Guest(s) shall not exceed the term of this Agreement between BellSouth and Smart City Communications.

3.3.2 Smart City Communications, as the Host, shall be the sole interface and responsible Party to BellSouth for the assessment and billing of rates and charges contained within this Attachment and for the purposes of ensuring that the safety and security requirements of this Attachment are fully complied with by the Guest(s), its employees and agents. BellSouth shall provide Smart City Communications with a pro-ration of the costs of the Collocation Space based on the number of collocators and the space used by each. There will be a minimum charge of one (1) bay/rack per Host/Guest. In addition to the above, for all states other than Florida, Smart City Communications shall be the responsible Party to BellSouth for the purpose of submitting applications for initial and additional equipment placement for the Guest(s). In Florida, the Guest(s) may submit its own Initial Application and Subsequent Applications for equipment placement using the Host's ACNA. A separate Guest application shall result in the assessment of an Initial Application Fee or a Subsequent Application Fee, as set forth in Exhibit B, which will be billed to the Host on the date that BellSouth provides its written Application Response to the Guest(s) Bona Fide application.

3.3.3 Notwithstanding the foregoing, the Guest(s) may submit service orders directly to BellSouth to request the provisioning of interconnecting facilities between BellSouth and the Guest(s), the provisioning of services, and/or access to Network Elements. The bill for these interconnecting facilities, services and Network Elements will be charged to the Guest(s) pursuant to the applicable BellSouth Tariff or the Guest's Interconnection Agreement with BellSouth.

3.3.4 Smart City Communications shall indemnify and hold harmless BellSouth from any and all claims, actions, causes of action, of whatever kind or nature arising

out of the presence of Smart City Communications's Guest(s) in the Collocation Space, except to the extent caused by BellSouth's sole negligence, gross negligence, or willful misconduct.

3.4 Adjacent Collocation

- 3.4.1 Subject to technical feasibility and space availability, BellSouth will permit an adjacent collocation arrangement (Adjacent Arrangement) on BellSouth Premises' property only when space within the requested BellSouth Premises is legitimately exhausted and where the Adjacent Arrangement does not interfere with access to existing or planned structures or facilities on the BellSouth Premises' property. An Adjacent Arrangement shall be constructed or procured by Smart City Communications or Smart City Communications's BellSouth Certified Supplier and must be in conformance with the provisions of BellSouth's design and construction specifications. Further, Smart City Communications shall construct, procure, maintain and operate said Adjacent Arrangement pursuant to all of the applicable rates, terms and conditions set forth in this Attachment.
- 3.4.2 If Smart City Communications requests Adjacent Collocation, pursuant to the conditions stated in Section 3.4 above, Smart City Communications must arrange with a BellSouth Certified Supplier to construct or procure the Adjacent Arrangement structure in accordance with BellSouth's specifications. BellSouth will provide the appropriate specifications upon request. Where local building codes require specifications more stringent than BellSouth's own specifications, Smart City Communications and Smart City Communications's BellSouth Certified Supplier shall comply with the more stringent local building code requirements. Smart City Communications's BellSouth Certified Supplier shall be responsible for filing and obtaining any and all necessary zoning, permits and/or licenses for such construction. Smart City Communications's BellSouth Certified Supplier shall bill Smart City Communications directly for all work performed for Smart City Communications to comply with this Attachment. BellSouth shall have no liability for, nor responsibility to pay such charges imposed by Smart City Communications's BellSouth Certified Supplier. Smart City Communications must provide the local BellSouth contact with two (2) cards, keys or other access devices used to gain entry into the locked enclosure. Except in the case of an emergency, BellSouth will not access Smart City Communications's locked enclosure prior to notifying Smart City Communications at least forty-eight (48) hours or two (2) business days, whichever is greater, before access to the Collocation Space is required.
- 3.4.3 Smart City Communications must submit its Adjacent Arrangement construction plans and specifications to BellSouth when it places its Firm Order. BellSouth shall review Smart City Communications's plans and specifications prior to the construction of an Adjacent Arrangement to ensure Smart City Communications's compliance with BellSouth's specifications. BellSouth shall complete its review within fifteen (15) days after receipt of the plans and specifications from Smart City Communications for the Adjacent Arrangement. BellSouth may inspect the



Adjacent Arrangement during and after construction is completed to ensure that it is constructed according to Smart City Communications's submitted plans and specifications. If BellSouth decides to inspect the completed Adjacent Arrangement, BellSouth will complete its inspection within fifteen (15) days after receipt of Smart City Communications's written notification that the Adjacent Arrangement has been completed. Within seven (7) days after BellSouth has completed its inspection of Smart City Communications's Adjacent Arrangement, BellSouth shall require Smart City Communications, at Smart City Communications's expense, to remove or correct any structure that does not meet its submitted plans and specifications or BellSouth's specifications, as applicable.

3.4.4 Smart City Communications shall provide a concrete pad, the structure housing the Adjacent Arrangement, HVAC, lighting and all of the facilities that are required to connect the structure (i.e., racking, conduits, etc.) to the BellSouth point of demarcation. At Smart City Communications's option and where the local authority having jurisdiction permits, BellSouth shall provide an AC power source and access to physical Collocation services and facilities, subject to the same nondiscriminatory requirements as those applicable to any other physical Collocation arrangement. BellSouth shall allow Shared Caged Collocation within an Adjacent Arrangement, pursuant to the terms and conditions set forth in Section 3.3 above.

3.5 Direct Connect

3.5.1 BellSouth will permit Smart City Communications to directly interconnect between its own physical/virtual Collocation Spaces within the same BellSouth Premises (Direct Connect). Smart City Communications shall contract with a BellSouth Certified Supplier to place the Direct Connect, which shall be provisioned using facilities owned by Smart City Communications. A Direct Connect shall utilize BellSouth common cable support structure. There will be a recurring charge per linear foot, per cable, of the actual common cable support structure used by Smart City Communications to provision the Direct Connect between its physical/virtual Collocation Spaces. In those instances where Smart City Communications's physical/virtual Collocation Spaces are contiguous in the central office, Smart City Communications will have the option of using Smart City Communications's own technicians to deploy the Direct Connect using either electrical or optical facilities between its Collocation Spaces by constructing its own dedicated cable support structure. Smart City Communications will deploy such electrical or optical connections directly between its own equipment without being routed through BellSouth's equipment or common cable support structure. Smart City Communications may not self-provision a Direct Connect on any BellSouth distribution frame, Point of Termination (POT) Bay, Digital System Cross-Connect (DSX) panel or Light Guide Cross-Connect (LGX) panel. Smart City Communications is solely responsible for ensuring the integrity of the signal.

3.5.2 To place an order for a Direct Connect, Smart City Communications must submit an Initial Application or Subsequent Application to BellSouth. If no modification to the Collocation Space is requested other than the placement of a Direct

Connect, the Co-Carrier Cross Connect/Direct Connect Application Fee for Direct Connect, as defined in Exhibit B, will apply. If other modifications are requested, in addition to the placement of a Direct Connect, either an Initial Application Fee or a Subsequent Application Fee will apply, pursuant to Section 6.2 below. BellSouth will bill this nonrecurring charge on the date that BellSouth provides an Application Response to Smart City Communications.

3.6 Co-Carrier Cross Connect (CCXC)

3.6.1 A CCXC is a cross connection between Smart City Communications and another collocated telecommunications carrier, other than BellSouth, in the same BellSouth Premises. Where technically feasible, BellSouth will permit Smart City Communications to interconnect between its Collocation Space(s) and the physical/virtual collocation space(s) of another collocated telecommunications carrier(s) within the same BellSouth Premises via a CCXC, pursuant to the FCC's Rules. The other collocated telecommunications carrier's agreement must also contain CCXC rates, terms and conditions before BellSouth will permit the provisioning of a CCXC between the two (2) collocated carriers. The applicable BellSouth charges will be assessed to Smart City Communications upon Smart City Communications's request for the CCXC. Smart City Communications is prohibited from using the Collocation Space for the sole or primary purpose of cross-connecting to other collocated telecommunications carriers.

3.6.2 Smart City Communications must contract with a BellSouth Certified Supplier to place the CCXC. The CCXC shall be provisioned using facilities owned by Smart City Communications. Such cross-connections to other collocated telecommunications carriers may be made using either electrical or optical facilities. Smart City Communications shall be responsible for providing a LOA, with the application, to BellSouth from the other collocated telecommunications carrier to which it will be cross-connecting. The CCXC shall utilize BellSouth common cable support structure. There will be a recurring charge per linear foot, per cable, of the common cable support structure used by Smart City Communications to provision the CCXC to the other collocated telecommunications carrier. In those instances where Smart City Communications's equipment and the equipment of the other collocated telecommunications carrier are located in contiguous caged Collocation Space, Smart City Communications may use its own technicians to install the CCXC using either electrical or optical facilities between the equipment of both collocated telecommunications carriers by constructing a dedicated cable support structure between the two (2) contiguous cages. Smart City Communications shall deploy such electrical or optical cross-connections directly between its own equipment and the equipment of the other collocated telecommunications carrier without being routed through BellSouth's equipment or, in the case of a CCXC provisioned between contiguous collocation spaces, common cable support structure. Smart City Communications shall not provision CCXC on any BellSouth distribution frame, POT Bay, DSX panel or LGX panel. Smart City Communications is solely responsible for ensuring the integrity of the signal.

- 3.6.3 To place an order for a CCXC, Smart City Communications must submit an application to BellSouth. If no modification to the Collocation Space is requested other than the placement of a CCXC, the Co-Carrier Cross Connect/Direct Connect Application Fee for a CCXC, as defined in Exhibit B, will apply. If other modifications are requested, in addition to the placement of a CCXC, either an Initial Application or a Subsequent Application Fee will apply, pursuant to Section 6.2 below. BellSouth will bill this nonrecurring charge on the date that it provides an Application Response to Smart City Communications.

#### **4 Occupancy**

- 4.1 Space Ready Notification. BellSouth will notify Smart City Communications in writing when the Collocation Space is ready for occupancy (Space Ready Date).
- 4.2 Acceptance Walkthrough. Smart City Communications will schedule and complete an acceptance walkthrough of new or additional provisioned Collocation Space with BellSouth within fifteen (15) days after the Space Ready Date. BellSouth will correct any identified deviations from Smart City Communications's original or jointly amended application within seven (7) days after the walkthrough, unless the Parties mutually agree upon a different time frame. BellSouth will then establish a new Space Ready Date. Another acceptance walkthrough will be scheduled and conducted within fifteen (15) days after the new Space Ready Date. This follow-up acceptance walkthrough will be limited to only those deviations identified in the initial walkthrough. If Smart City Communications completes its acceptance walkthrough within the fifteen (15) day interval associated with the applicable Space Ready Date, billing will begin upon the date of Smart City Communications's acceptance of the Collocation Space (Space Acceptance Date). In the event Smart City Communications fails to complete an acceptance walkthrough within the fifteen (15) day interval associated with the applicable Space Ready Date, the Collocation Space shall be deemed accepted by Smart City Communications on the Space Ready Date and billing will commence from that date.
- 4.3 Early Space Acceptance. If Smart City Communications decides to occupy the Collocation Space prior to the Space Ready Date, the date Smart City Communications executes the Agreement for Customer Access and Acceptance to Unfinished Collocation Space is the date that will be deemed the Space Acceptance Date and billing will begin from that date.
- 4.4 Equipment Installation. Smart City Communications shall notify BellSouth in writing that its collocation equipment installation is complete. Smart City Communications's collocation equipment installation is complete when Smart City Communications's equipment is connected to BellSouth's network for the purpose of provisioning Telecommunication Services to Smart City Communications's customers. BellSouth may refuse to accept any orders for cross-connects until it has received such notice from Smart City Communications.
- 4.5 Termination of Occupancy.
- 4.5.1 In addition to any other provisions addressing termination of occupancy in this

Agreement, Smart City Communications may terminate its occupancy of a particular Collocation Space by submitting a Subsequent Application requesting termination of occupancy for such Collocation Space. Such termination shall be effective upon BellSouth's acceptance of the Space Relinquishment Form. Billing for monthly recurring charges will cease on the date that Smart City Communications and BellSouth conduct an inspection of the terminated space and jointly sign off on the Space Relinquishment Form or on the date that Smart City Communications signs off on the Space Relinquishment Form and sends this form to BellSouth, provided no discrepancies are found during BellSouth's subsequent inspection of the terminated space. If the subsequent inspection by BellSouth reveals any discrepancies, billing will cease on the date that BellSouth and Smart City Communications jointly conduct an inspection, confirming that Smart City Communications has corrected all of the noted discrepancies identified by BellSouth. A Subsequent Application Fee will not apply for the termination of occupancy; however, specific disconnect fees may apply to the services terminating to such Collocation Space. The particular disconnect fees that would apply in each state are contained in Exhibit B.

- 4.5.2 Upon termination of occupancy, Smart City Communications, at its sole expense, shall remove its equipment and any other property owned, leased or controlled by Smart City Communications from the Collocation Space. Smart City Communications shall have thirty (30) days from the Bona Fide Firm Order (BFFO) date (Termination Date) to complete such removal, including the removal of all equipment and facilities of Smart City Communications's Guest(s), unless Smart City Communications's Guest(s) has assumed responsibility for the Collocation Space housing the Guest(s)'s equipment and executed the appropriate documentation required by BellSouth to transfer the Collocation Space to the Guest(s) prior to Smart City Communications's Termination Date.
- 4.5.3 Smart City Communications shall continue the payment of all monthly recurring charges to BellSouth until the date Smart City Communications, and if applicable Smart City Communications's Guest(s), has fully vacated the Collocation Space and the Space Relinquishment Form has been accepted by BellSouth. If Smart City Communications or Smart City Communications's Guest(s) fails to vacate the Collocation Space within thirty (30) days from the Termination Date, BellSouth shall have the right to remove and dispose of the equipment and any other property of Smart City Communications or Smart City Communications's Guest(s), in any manner that BellSouth deems fit, at Smart City Communications's expense and with no liability whatsoever for Smart City Communications's property or Smart City Communications's Guest(s) property.
- 4.5.4 Upon termination of Smart City Communications's right to occupy specific Collocation Space, the Collocation Space will revert back to BellSouth's central office space inventory. Smart City Communications shall surrender the Collocation Space to BellSouth in the same condition as when it was first occupied by Smart City Communications, with the exception of ordinary wear and tear, unless otherwise agreed to by the Parties. Smart City Communications's

BellSouth Certified Supplier shall be responsible for updating and making any necessary changes to BellSouth's records as required by BellSouth specifications including, but not limited to, BellSouth's Central Office Record Drawings and ERMA Records. Smart City Communications shall be responsible for the cost of removing any Smart City Communications constructed enclosure, as well as any supporting structures (e.g., racking, conduits, power cables, etc.), by the Termination Date and restoring the grounds to their original condition.

## **5 Use of Collocation Space**

### **5.1 Equipment Type**

- 5.1.1 BellSouth shall permit the collocation and use of any equipment necessary for interconnection to BellSouth's network and/or access to BellSouth's unbundled network elements in the provision of Telecommunications Services, as the term "necessary" is defined by FCC 47 C.F.R. § 51.323 (b). The primary purpose and function of any equipment collocated in a BellSouth Premises must be for interconnection to BellSouth's network or access to BellSouth's unbundled network elements in the provision of Telecommunications Services. Equipment is necessary for interconnection if an inability to deploy that equipment would, as a practical, economical, or operational matter, preclude the requesting carrier from obtaining interconnection with BellSouth at a level equal in quality to that which BellSouth obtains within its own network or what BellSouth provides to any affiliate, subsidiary, or other party.
- 5.1.2 Examples of equipment that would not be considered necessary include, but are not limited to: traditional circuit switching equipment, equipment used exclusively for call-related databases, computer servers used exclusively for providing information services, OSS equipment used to support collocated telecommunications carrier network operations, equipment that generates customer orders, manages trouble tickets or inventory, or stores customer records in centralized databases, etc. BellSouth will determine upon receipt of an application if the requested equipment is necessary based on the criteria established by the FCC. Multifunctional equipment placed on a BellSouth Premises must not place any greater relative burden on BellSouth's property than comparable single-function equipment. BellSouth reserves the right to allow the collocation of any equipment on a nondiscriminatory basis.
- 5.1.3 Such equipment must, at a minimum, meet the following Telcordia Network Equipment Building Systems (NEBS) General Equipment Requirements: for Central Offices Criteria Level 1 requirements as outlined in Telcordia Special Report SR-3580, Issue 1 and for Remote Sites Criteria Level 3 requirements as outlined in the Telcordia Special report SR-3580, Issue 1. Except where otherwise required by a Commission, BellSouth shall comply with the applicable FCC rules relating to denial of collocation equipment based on Smart City Communications's failure to comply with this Section.
- 5.1.3.1 To the extent Smart City Communications wishes to place equipment in its collocation that does not meet the standards set forth in 5.1.3, Smart City

Communications may request in writing, pursuant to the Notices section of the General Terms & Conditions, a waiver to such standards. BellSouth may provide a waiver in its sole discretion.

- 5.1.4 At a Remote Site, all Smart City Communications equipment installation shall comply with BellSouth TR 73503-11h, “Grounding - Engineering Procedures”. Metallic cable sheaths and metallic strength members of optical fiber cables as well as the metallic cable sheaths of all copper conductor cables shall be bonded to the designated grounding bus for the Remote Site Location. All copper conductor pairs, working and non-working, shall be equipped with a solid-state protector unit (over-voltage protection only), which has been listed by a nationally recognized testing laboratory.
- 5.2 Terminations. Smart City Communications shall not request more DS0, DS1, DS3 and/or optical terminations for a collocation arrangement than the total port or termination capacity of the equipment physically installed in the Collocation Space. The total capacity of the equipment collocated in the Collocation Space will include equipment contained in an application, as well as any equipment already placed in the Collocation Space. If full network termination capacity of the equipment being installed is not requested in the application submitted by Smart City Communications, additional network terminations for the installed equipment will require the submission of a Subsequent Application. In the event Smart City Communications submits an application for terminations that will exceed the total capacity of the collocated equipment, Smart City Communications will be informed of the discrepancy by BellSouth and required to submit a revision to the application.
- 5.3 Security Interest in Equipment. Commencing with the most current calendar quarter after the Effective Date of this Agreement, and thereafter with respect to each subsequent calendar quarter during the term of this Agreement, Smart City Communications will, no later than thirty (30) days after the close of such calendar quarter, provide a report to ICS Collocation Product Management, Room 34th Floor, 675 W. Peachtree Street, Atlanta, Georgia 30375, listing any equipment in the Collocation Space (i) that was added during the calendar quarter to which such report pertains, and (ii) for which there is a UCC-1 lien holder or to another entity that has a secured financial interest in such equipment (Secured Equipment). If no Secured Equipment has been installed within a given calendar quarter, no report shall be due hereunder in connection with such calendar quarter.
- 5.4 No Marketing. Smart City Communications shall not use the Collocation Space for marketing purposes, nor shall it place any identifying signs or markings outside the Collocation Space or on the grounds of the BellSouth Premises.
- 5.5 Equipment Identification. Smart City Communications shall place a plaque or affix other identification (e.g., stenciling or labeling) to each piece of Smart City Communications’s equipment, including the appropriate emergency contacts with their corresponding telephone numbers, in order for BellSouth to properly identify Smart City Communications’s equipment in the case of an emergency. For caged

Collocation Space, such identification must be placed on a plaque affixed to the outside of the caged enclosure.

- 5.6 Entrance Facilities.
- 5.6.1 Smart City Communications may elect to place Smart City Communications-owned or Smart City Communications leased fiber entrance facilities into its Collocation Space. BellSouth will designate the point of interconnection in close proximity to the BellSouth Premises housing the Collocation Space, such as at an entrance manhole or a cable vault for Central Offices, which is physically accessible by both Parties. For Central Offices, Smart City Communications will provide and place fiber cable in the entrance manhole of sufficient length to be pulled through conduit and into the splice location. Smart City Communications will provide and install a sufficient length of fire retardant riser cable, to which BellSouth will splice the entrance cable. The fire retardant riser cable will extend from the splice location to Smart City Communications's equipment in Smart City Communications's Collocation Space. In the event Smart City Communications utilizes a non-metallic, riser-type entrance facility, a splice will not be required. For Remote Terminals Smart City Communications will provide and place copper cable through conduit from the Remote Site Collocation Space to the feeder distribution interface. Such copper cable must be of sufficient length to reach the splice location for splicing by BellSouth. Smart City Communications must contact BellSouth for authorization and instruction prior to placing any entrance facility cable in an entrance manhole or cable vault. Smart City Communications is responsible for the maintenance of the entrance facilities. Nonrecurring charges for cable installation will be assessed on a per cable basis as set forth in Exhibit B upon receipt of Smart City Communications's BFFO. Recurring charges for the cable support structure will be billed at the rates set forth in Exhibit B.
- 5.6.2 Central Office Microwave Transmission Facilities. At Smart City Communications's request, BellSouth will accommodate, where technically feasible and space is available, a microwave entrance facility, pursuant to separately negotiated rates, terms and conditions.
- 5.6.3 Central Office Copper and Coaxial Cable Entrance Facilities. In Florida, BellSouth shall permit Smart City Communications to use copper or coaxial cable entrance facilities, if approved by the Commission, but only in those rare instances where Smart City Communications demonstrates a necessity and entrance capacity is not at or near exhaust in a particular BellSouth Premises in which Smart City Communications's Collocation Space is located. In Florida, Smart City Communications must have approval by the Commission before it submits a request for copper entrance facilities. Notwithstanding the foregoing, in the case of adjacent collocation, copper facilities may be used between the adjacent collocation arrangement and the central office demarcation point, unless BellSouth determines that limited space is available for the placement of these entrance facilities.

- 5.7 Dual Entrance Facilities at a Central Office. BellSouth will provide at least two (2) interconnection points at each Central Office where at least two (2) such interconnection points are available and capacity exists. Upon receipt of a request by Smart City Communications for dual entrance facilities to its physical Collocation Space, BellSouth shall provide Smart City Communications with information regarding BellSouth's capacity to accommodate the requested dual entrance facilities. If conduit in the serving manhole(s) is available and is not reserved for another purpose or for utilization within twelve (12) months of the receipt of an application for collocation, BellSouth will make the requested conduit space available for the installation of a second entrance facility to Smart City Communications's Collocation Space. The location of the serving manhole(s) will be determined at the sole discretion of BellSouth. Where dual entrance facilities are not available due to a lack of capacity, BellSouth will provide this information to Smart City Communications in the Application Response.
- 5.8 Shared Use
- 5.8.1 Smart City Communications may utilize spare capacity on an existing telecommunications carrier's entrance facility for the purpose of obtaining an entrance facility to Smart City Communications's Collocation Space within the same BellSouth Premises.
- 5.8.2 BellSouth shall allow the splice, as long as the fiber is non-working dark fiber. Smart City Communications must arrange with BellSouth in accordance with BellSouth's Special Construction Procedures, RL93-11-030BT, and provide a LOA from the other telecommunications carrier authorizing BellSouth to perform the splice of the Smart City Communications-provided riser cable to the spare capacity on the other telecommunications carrier's entrance facility. If Smart City Communications desires to allow another telecommunications carrier to use its entrance facilities, the telecommunications carrier must arrange with BellSouth in accordance with BellSouth's Special Construction Procedures, RL93-11-030BT, and provide a LOA from Smart City Communications authorizing BellSouth to perform the splice of the telecommunications carrier's provided riser cable to the spare capacity on Smart City Communications's entrance facility.
- 5.9 Demarcation Point
- 5.9.1 BellSouth will designate the point(s) of demarcation between Smart City Communications's equipment and/or network facilities and BellSouth's network facilities. For 2-wire and 4-wire connections, the demarcation point shall be a common block on the BellSouth designated conventional distribution frame. Smart City Communications shall be responsible for providing the common block and cabling and Smart City Communications's BellSouth Certified Supplier shall be responsible for installing and properly labeling/stenciling the common block and any necessary cabling identified in Section 7 below. For DS1, DS3, STS1, and optical terminations, BellSouth shall designate, provide, and install demarcation point hardware on a per arrangement basis. Smart City



Communications shall be responsible for providing, and Smart City Communications's BellSouth Certified Supplier shall be responsible for installing any necessary cabling and properly labeling/stenciling the demarcation point hardware for terminations identified in Section 7 below.

- 5.9.2 Smart City Communications or its agent must install, maintain and operate the equipment/facilities on its side of the demarcation point, pursuant to Section 5.10 below and may self-provision cross-connects that may be required within its own Collocation Space to activate service requests.
- 5.10 Equipment and Facilities. Smart City Communications, or if required by this Attachment, Smart City Communications's BellSouth Certified Supplier, is solely responsible for the design, engineering, installation, testing, provisioning, performance, monitoring and maintenance/repair of the equipment and network facilities used by Smart City Communications, which must be performed in compliance with all applicable BellSouth specifications. Such equipment and network facilities may include, but are not limited to, cable(s), equipment, and POT connections. Smart City Communications and its designated BellSouth Certified Supplier must follow and comply with all BellSouth specifications outlined in the following BellSouth Technical Requirements: TR 73503, TR 73519, TR 73572 and TR 73564.
- 5.11 BellSouth's Access to Collocation Space
- 5.11.1 From time to time, BellSouth may require access to Smart City Communications's Collocation Space. BellSouth retains the right to access Smart City Communications's Collocation Space for the purpose of making BellSouth equipment and building modifications (e.g., installing, altering or removing racking, ducts, electrical wiring, HVAC, and cabling). In such cases, BellSouth will give notice to Smart City Communications at least forty-eight (48) hours before access to Smart City Communications's Collocation Space is required. Smart City Communications may elect to be present whenever BellSouth performs work in the Smart City Communications's Collocation Space. The Parties agree that Smart City Communications will not bear any of the expense associated with this type of work.
- 5.11.2 In the case of an emergency, BellSouth will provide oral notice of entry as soon as reasonably practicable after such entry.
- 5.11.3 Smart City Communications must provide the local BellSouth Central Office Building Contact with two (2) Access Devices that will allow BellSouth entry into any enclosed and locked Collocation Space including, but not limited to, an Adjacent Arrangement, pursuant to the requirements contained in this Section.
- 5.12 Smart City Communications's Access
- 5.12.1 Pursuant to Section 12 below, Smart City Communications shall have access to its Collocation Space twenty-four (24) hours a day, seven (7) days a week. Smart City Communications agrees to provide the name, date of birth and either the social security number or driver's license number of each employee, supplier or

agent of Smart City Communications or Smart City Communications's Guest(s) with Smart City Communications's written request for access keys or cards (Access Devices) for specific BellSouth Premises, prior to the issuance of said Access Devices, using Form RF-2906-C, the "CLEC and CLEC Certified Supplier Access Request and Acknowledgement" form. The appropriate key acknowledgement forms (the "Collocation Acknowledgement Sheet" for access cards and the "Key Acknowledgement Form" for keys) must be signed by Smart City Communications and returned to BellSouth Access Management within fifteen (15) days of Smart City Communications's receipt of these forms. Failure to return these properly acknowledged forms will result in the subsequent access key or card requests being held by BellSouth until the proper acknowledgement documents have been received by BellSouth and reflect current information. Charges for Security Access System and for Security Access Devices will be billed at the rates set forth in Exhibit B. Access Devices may not be duplicated under any circumstances. Smart City Communications agrees to be responsible for all Access Devices and for the return of all Access Devices in the possession of Smart City Communications's employees, suppliers, agents or Guests after termination of the employment relationship, the contractual obligation with Smart City Communications ends, upon the termination of this Agreement, or upon the termination of occupancy of Collocation Space in a specific BellSouth Premises. Smart City Communications shall pay all applicable charges associated with lost or stolen Access Devices.

5.12.2 Smart City Communications must submit to BellSouth the completed Access Control Request Form for all employees, suppliers, agents or Guests requiring access to a BellSouth Premises at least thirty (30) days prior to the date Smart City Communications desires to gain access to the Collocation Space. In order to permit reasonable access during construction of the Collocation Space, Smart City Communications may submit a request for its one (1) free accompanied site visit to its designated Collocation Space at any time subsequent to BellSouth's receipt of the BFFO. In the event Smart City Communications desires access to its designated Collocation Space after the first accompanied free visit and Smart City Communications's access request form(s) has not been approved by BellSouth or Smart City Communications has not yet submitted an access request form to BellSouth, Smart City Communications shall be permitted to access the Collocation Space accompanied by a BellSouth security escort, at Smart City Communications's expense, which will be assessed pursuant to the Security Escort fees contained in Exhibit B. Smart City Communications must request that escorted access be provided by BellSouth to Smart City Communications's designated Collocation Space at least three (3) business days prior to the date such access is desired. A BellSouth security escort will be required whenever Smart City Communications or its approved agent or supplier requires access to the entrance manhole.

5.13 Lost or Stolen Access Devices. Smart City Communications shall immediately notify BellSouth in writing when any of its Access Devices have been lost or stolen. If it becomes necessary for BellSouth to re-key buildings or deactivate an

Access Device as a result of a lost or stolen Access Device(s) or for failure of Smart City Communications's employees, suppliers, agents or Guest(s) to return an Access Device(s), Smart City Communications shall pay for the costs of re-keying the building or deactivating the Access Device(s).

5.14 Interference or Impairment

5.14.1 Notwithstanding any other provisions of this Attachment, Smart City Communications shall not use any product or service provided under this Agreement, any other service related thereto or used in combination therewith, or place or use any equipment or facilities in any manner that (1) significantly degrades, interferes with or impairs service provided by BellSouth or any other entity or any person's use of its telecommunications services; (2) endangers or damages the equipment, facilities or any other property of BellSouth or any other entity or person; (3) compromises the privacy of any communications routed through the BellSouth Premises; or (4) creates an unreasonable risk of injury or death to any individual or to the public. If BellSouth reasonably determines that any equipment or facilities of Smart City Communications violates the provisions of this paragraph, BellSouth shall provide written notice to Smart City Communications, which shall direct Smart City Communications to cure the violation within forty-eight (48) hours of Smart City Communications's receipt of written notice or, if such cure is not feasible, at a minimum, to commence curative measures within twenty-four (24) hours and exercise reasonable diligence to complete such measures as soon as possible thereafter. After receipt of the notice, the Parties agree to consult immediately and, if necessary, to conduct an inspection of the Collocation Space.

5.14.2 Except in the case of the deployment of an advanced service which significantly degrades the performance of other advanced services or traditional voice band services, if Smart City Communications fails to cure the violation within forty-eight (48) hours or, if such cure is not possible, to commence curative action within twenty-four (24) hours and exercise reasonable diligence to complete such action as soon as possible, or if the violation is of a character that poses an immediate and substantial threat of damage to property or injury or death to any person, or any other significant degradation, interference or impairment of BellSouth's or another entity's service, then and only in that event, BellSouth may take such action as it deems necessary to eliminate such threat including, without limitation, the interruption of electrical power to Smart City Communications's equipment and/or facilities. BellSouth will endeavor, but is not required, to provide notice to Smart City Communications prior to the taking of such action and BellSouth shall have no liability to Smart City Communications for any damages arising from such action, except to the extent that such action by BellSouth constitutes willful misconduct.

5.14.3 For purposes of this Section, the term "significantly degrades" shall be defined as an action that noticeably impairs a service from a user's perspective. In the case of the deployment of an advanced service which significantly degrades the performance of other advanced services or traditional voice band services and

Smart City Communications fails to cure the violation within forty-eight (48) hours, or if such cure is not possible, to commence curative action within twenty-four (24) hours and exercise reasonable diligence to complete such action as soon as possible, BellSouth will establish before the appropriate Commission that the technology deployed is causing the significant degradation. Any claims of network harm presented to Smart City Communications or, if subsequently necessary, the Commission must be provided by BellSouth with specific and verifiable information. When BellSouth demonstrates that a certain technology deployed by Smart City Communications is significantly degrading the performance of other advanced services or traditional voice band services, Smart City Communications shall discontinue deployment of that technology and migrate its customers to other technologies that will not significantly degrade the performance of such services. Where the only degraded service itself is a known disturber, and the newly deployed technology satisfies at least one of the criteria for a presumption that it is acceptable for deployment, pursuant to 47 C.F.R. § 51.230, the degraded service shall not prevail against the newly-deployed technology.

- 5.15 Personalty and Its Removal. Facilities and equipment placed by Smart City Communications in the Collocation Space shall not become a part of the Collocation Space, even if nailed, screwed or otherwise fastened to the Collocation Space, but shall retain their status as personal property and may be removed by Smart City Communications at any time. Any damage caused to the Collocation Space by Smart City Communications’s employees, suppliers, agents or Guests during the installation or removal of such property shall be promptly repaired by Smart City Communications at its sole expense. If Smart City Communications decides to remove equipment and/or facilities from its Collocation Space and the removal requires no physical work be performed by BellSouth and Smart City Communications’s physical work includes, but is not limited to, power reduction, cross-connects, or tie pairs, BellSouth will bill Smart City Communications the Administrative Only Application Fee associated with the type of removal activity performed by Smart City Communications, as set forth in Exhibit B. This nonrecurring fee will be billed on the date that BellSouth provides an Application Response to Smart City Communications.
- 5.16 Alterations. Under no condition shall Smart City Communications or any person acting on behalf of Smart City Communications make any rearrangement, modification, augment, improvement, addition, and/or other alteration which could affect in any way space, power, HVAC, and/or safety considerations to the Collocation Space or the BellSouth Premises, hereinafter referred to individually or collectively as “Alterations”, without the express written consent of BellSouth, which shall not be unreasonably withheld. The cost of any such Alteration shall be paid by Smart City Communications. An Alteration shall require the submission of a Subsequent Application and will result in the assessment of the applicable application fee associated with the type of alteration requested, as set forth in Sections 6.2.1 and 7.1.4 below, which will be billed by BellSouth on the

date that BellSouth provides Smart City Communications with an Application Response.

5.17 Central Office Janitorial Service. Smart City Communications shall be responsible for the general upkeep of its Collocation Space. Smart City Communications shall arrange directly with a BellSouth Certified Supplier for janitorial services applicable to caged Collocation Space. Upon request, BellSouth shall provide a list of such suppliers on a BellSouth Premises-specific basis.

5.18 Upkeep of Remote Collocation Space. Smart City Communications shall be responsible for the general upkeep and cleaning of the Remote Collocation Space. Smart City Communications shall be responsible for removing any of Smart City Communications's debris from the Remote Collocation Space and from in and around the Remote Site Location on each visit.

## **6 Ordering and Preparation of Collocation Space**

6.1 Initial Application. For Smart City Communications's or Smart City Communications's Guest's(s') initial equipment placement, Smart City Communications shall input a physical Expanded Interconnection Application Document (Initial Application) for physical Collocation Space directly into BellSouth's electronic application (e.App) system for processing. The Initial Application is considered Bona Fide when it is complete and accurate, meaning that all of the required fields on the Initial Application are completed with the appropriate type of information. An Initial Application Fee, as set forth in Exhibit B, will apply to each Initial Application submitted by Smart City Communications for Central Office or Remote Site Collocation, as applicable, and will be billed by BellSouth on the date BellSouth provides Smart City Communications with an Application Response.

6.1.1 For Remote Site Collocation, a request for additional space at a later date will require the submission of an Initial Application. The installation of additional shelves/equipment within an existing bay does not require an Initial Application.

6.2 Subsequent Application. In the event Smart City Communications or Smart City Communications's Guest(s) desires to modify its use of the Collocation Space in a Central Office after a BFFO, Smart City Communications shall complete an application that contains all of the detailed information associated with a requested Alteration of the Collocation Space, as defined in Section 5.15 above (Subsequent Application). The Subsequent Application will be considered Bona Fide when it is complete and accurate, meaning that all of the required fields on the Subsequent Application have been completed with the appropriate type of information associated with the requested Alteration. BellSouth shall determine what modifications, if any, to the BellSouth Premises are required to accommodate the change(s) requested by Smart City Communications in the Subsequent Application. Such modifications to the BellSouth Premises may include, but are not limited to, floor loading changes, changes necessary to meet

HVAC requirements, changes to power plant requirements, equipment additions, etc.

6.2.1 Subsequent Application Fees. The application fee paid by Smart City Communications for an Alteration in a Central Office shall be dependent upon the level of assessment needed to provide a complete Application Response for the Alteration requested. Where the Subsequent Application does not require provisioning or construction work, but requires BellSouth to perform an administrative activity, an Administrative Only Application Fee shall apply as set forth in Exhibit B. The Administrative Only Application Fee will apply to Subsequent Applications associated with a transfer of ownership of the Collocation Space, the addition, exchange or removal of equipment from the Collocation Space (where the removal requires no physical work to be performed by BellSouth which require no additional space, power or terminations to be provided to Smart City Communications's collocation arrangement), and a virtual-to-physical conversion (in place). The Co-Carrier Cross Connect/Direct Connect Application Fee will apply when Smart City Communications submits a Subsequent Application for a direct connection between its own physical and virtual Collocation Space(s) in the same BellSouth Central Office or between its physical or virtual Collocation Space and that of another collocated telecommunications carrier within the same BellSouth Central Office. In Florida, the Power Reconfiguration Only Application Fee will apply when Smart City Communications submits a Subsequent Application that reflects only an upgrade or reduction in the amount of power that BellSouth is currently providing to Smart City Communications's physical Collocation Space in a Central Office. The fee for a Subsequent Application, for which the Alteration requested has limited effect (e.g., requires limited assessment and sufficient cable support structure, HVAC, power and terminations are available), shall be the Subsequent Application Fee, as set forth in Exhibit B. The appropriate nonrecurring application fee will be billed on the date that BellSouth provides Smart City Communications with an Application Response.

6.3 Space Preferences. If Smart City Communications has previously requested and received a Space Availability Report for the BellSouth Premises, Smart City Communications may submit up to three (3) space preferences on its application by identifying the specific space identification numbers referenced on the Space Availability Report for the space it is requesting. In the event BellSouth cannot accommodate Smart City Communications's space preference(s), Smart City Communications may accept the space allocated by BellSouth or cancel its application and submit another application requesting additional space preferences for the same BellSouth Premises. This application will be treated as a new application and the appropriate application fee will apply. The application fee will be billed by BellSouth on the date that BellSouth provides Smart City Communications with an Application Response.

6.4 Space Availability Notification

6.4.1 For all states except Florida, BellSouth will respond to an application within ten

(10) days as to whether space is available or not available within the requested BellSouth Premises. In Florida, BellSouth will respond to an application within fifteen (15) days as to whether space is available or not available within a BellSouth Premises. BellSouth's e.App system will reflect when Smart City Communications's application is Bona Fide. If the application cannot be Bona Fide, BellSouth will identify what revisions are necessary for the application to become Bona Fide.

6.4.2 If the amount of space requested is not available, BellSouth will notify Smart City Communications of the amount of space that is available and no application fee will apply. When BellSouth's response includes an amount of space less than that requested by Smart City Communications or space that is configured differently, no application fee will apply. If Smart City Communications decides to accept the available space, Smart City Communications must resubmit its application to reflect the actual space available, including the configuration of the space, prior to submitting a BFFO. When Smart City Communications resubmits its application to accept the available space, BellSouth will bill Smart City Communications the appropriate application fee.

6.5 Denial of Application. If BellSouth notifies Smart City Communications that no space is available (Denial of Application), BellSouth will not assess an application fee to Smart City Communications. After notifying Smart City Communications that BellSouth has no available space in the requested BellSouth Premises, BellSouth will allow Smart City Communications, upon request, to tour the entire BellSouth Premises within ten (10) days of such Denial of Application. In order to schedule this tour, BellSouth must receive the request for the tour of the BellSouth Premises within five (5) days of the Denial of Application.

6.6 Petition for Waiver. Upon Denial of Application, BellSouth will timely file a petition with the appropriate Commission pursuant to 47 U.S.C. § 251(c)(6). BellSouth shall provide to the Commission any information requested by that Commission. Such information shall include which space, if any, BellSouth or any of BellSouth's affiliates have reserved for future use and a detailed description of the specific future uses for which the space has been reserved. Subject to an appropriate nondisclosure agreement or provision, BellSouth shall permit Smart City Communications to inspect any floor plans or diagrams that BellSouth provides to the Commission.

6.7 Waiting List

6.7.1 On a first-come, first-serve basis, which is governed by the date of receipt of an application or Letter of Intent, BellSouth will maintain a waiting list of requesting telecommunications carriers that have either received a Denial of Application or, where it is publicly known that a BellSouth Premises is out of space, have submitted a Letter of Intent to collocate in that BellSouth Premises. BellSouth will notify each telecommunications carrier on the waiting list that can be accommodated by the amount of space that becomes available, according to the position of the telecommunications carrier on said waiting list.

- 6.7.2 In Florida, on a first-come, first-serve basis, which is governed by the date of receipt of an application or Letter of Intent, BellSouth will maintain a waiting list of requesting telecommunications carriers that have either received a Denial of Application or, where it is publicly known that a BellSouth Premises is out of space, have submitted a Letter of Intent to collocate in that BellSouth Premises. Sixty (60) days prior to space becoming available, if known, BellSouth will notify the Commission and the telecommunications carriers on the waiting list by mail when space will become available. If BellSouth does not know sixty (60) days in advance of when space will become available, BellSouth will notify the Commission and the telecommunications carriers on the waiting list within two (2) business days of the determination that space will become available. A telecommunications carrier that, upon denial of physical Collocation Space, requests virtual Collocation Space shall automatically be placed on the waiting list for physical Collocation Space that may become available in the future.
- 6.7.3 When physical Collocation Space becomes available, Smart City Communications must submit an updated, complete and accurate application to BellSouth within thirty (30) days of notification by BellSouth that physical Collocation Space will be available in the requested BellSouth Premises previously out of space. If Smart City Communications has originally requested caged Collocation Space and cageless Collocation Space becomes available, Smart City Communications may refuse such space and notify BellSouth in writing, within the thirty (30) day timeframe referenced above, that Smart City Communications wishes to maintain its place on the waiting list for caged physical Collocation Space, without accepting the available cageless Collocation Space.
- 6.7.4 Smart City Communications may accept an amount of space less than what it originally requested by submitting an application as set forth above, and upon request, may maintain its position on the waiting list for the remaining space that was initially requested. If Smart City Communications does not submit an application or notify BellSouth in writing within the thirty (30) day timeframe as described in Section 6.7.2 above, BellSouth will offer the available space to the next telecommunications carrier on the waiting list and remove Smart City Communications from the waiting list. Upon request, BellSouth will advise Smart City Communications as to its position on the waiting list for a particular BellSouth Premises.
- 6.8 Public Notification. BellSouth will maintain on its Interconnection Web site, a notification document that will indicate all BellSouth Premises that are without available space. BellSouth shall update such document within ten (10) days of the date that BellSouth becomes aware that insufficient space is available to accommodate physical Collocation. BellSouth will also post a document on its Interconnection Web site that contains a general notice when space becomes available in a BellSouth Premises previously on the space exhaust list.
- 6.9 Application Response



6.9.1 In Florida, within fifteen (15) days of receipt of a Bona Fide application, when space has been determined to be available or when a lesser amount of space than that requested is available, then with respect to the space available, BellSouth will provide an Application Response including sufficient information to enable Smart City Communications to place a Firm Order. The Application Response will include, at a minimum, the configuration of the space, the Cable Installation Fee, the Cable Records Fee and any other applicable space preparation fees, as described in Section 8 below. When Smart City Communications submits ten (10) or more applications within ten (10) days, the initial fifteen (15) day response interval will increase by ten (10) days for every additional ten (10) applications or fraction thereof.

6.10 Application Modifications. If a modification or revision is made to any information in the Bona Fide application after BellSouth has provided the Application Response and prior to a BFFO, with the exception of modifications to (1) Customer Information, (2) Contact Information or (3) Billing Contact Information, whether at the request of Smart City Communications or as necessitated by technical considerations, the application shall be considered a new application and handled as a new application with respect to the response and provisioning intervals. BellSouth will charge Smart City Communications the appropriate application fee associated with the level of assessment performed by BellSouth, pursuant to Sections 6.1 and 6.2 above.

6.11 Bona Fide Firm Order

6.11.1 Smart City Communications shall indicate its intent to proceed with a Collocation Space request in a BellSouth Premises by submitting a BFFO to BellSouth. The BFFO must be received by BellSouth no later than thirty (30) days after BellSouth's Application Response to Smart City Communications's Bona Fide application or Smart City Communications's application will expire.

6.11.2 BellSouth will establish a Firm Order date based upon the date BellSouth is in receipt of Smart City Communications's BFFO. BellSouth will acknowledge the receipt of Smart City Communications's BFFO within seven (7) days of receipt, so that Smart City Communications will have positive confirmation that its BFFO has been received. BellSouth's response to a BFFO will include a Firm Order Confirmation, which contains the firm order date. No revisions may be made to a BFFO.

## **7 Construction and Provisioning**

7.1 Construction and Provisioning Intervals

7.1.1 In Florida, BellSouth will complete construction of physical Collocation Space as soon as possible within a maximum of ninety (90) days from receipt of a BFFO or as agreed to by the Parties. For virtual Collocation Space, BellSouth will complete construction as soon as possible within a maximum of sixty (60) days from receipt of a BFFO or as agreed to by the Parties. For Alterations requested to Collocation Space after the initial space has been completed, BellSouth will complete construction for Collocation Space as soon as possible within a

maximum of forty-five (45) days from receipt of a BFFO or as agreed to by the Parties, as long as no additional space has been requested by Smart City Communications. If additional space has been requested by Smart City Communications, BellSouth will complete construction for the requested Collocation Space as soon as possible within a maximum of ninety (90) days from receipt of a BFFO for physical Collocation Space and forty five (45) days from receipt of a BFFO for virtual Collocation Space. If BellSouth does not believe that construction will be completed within the relevant provisioning interval and BellSouth and Smart City Communications cannot agree upon a completion date, within forty-five (45) days of receipt of the BFFO for an initial request, or within thirty (30) days of receipt of the BFFO for an Alteration, BellSouth may seek an extension from the Commission.

- 7.1.2 Records Only Change. When Smart City Communications adds equipment, that was originally included on Smart City Communications's Initial Application or a Subsequent Application, and the installation of this equipment requires no additional space preparation work or cable terminations on the part of BellSouth, then BellSouth will impose no additional charges or intervals.
- 7.2 Joint Planning. Unless otherwise agreed to by the Parties, a joint planning meeting or other method of joint planning between BellSouth and Smart City Communications will commence within a maximum of twenty (20) days from BellSouth's receipt of a BFFO. At such meeting, the Parties will agree to the preliminary design of the Collocation Space and the equipment configuration requirements, as reflected in the application and affirmed in the BFFO.
- 7.3 Permits. Each Party, its agent(s) or BellSouth Certified Supplier(s) will diligently pursue filing for the permits required for the scope of work to be performed by that Party, its agent(s) or BellSouth Certified Supplier(s) within ten (10) days of the completion of the finalized construction design and specifications.
- 7.4 Central Office Circuit Facility Assignments
  - 7.4.1 Unless otherwise specified, BellSouth will provide Circuit Facility Assignments (CFAs) to Smart City Communications prior to the applicable provisioning interval set forth herein (Provisioning Interval) for those BellSouth Premises in which Smart City Communications has physical Collocation Space with no POT bay or with a grandfathered POT bay provided by BellSouth. BellSouth cannot provide CFAs to Smart City Communications prior to the Provisioning Interval for those BellSouth Premises in which Smart City Communications has physical Collocation Space with a POT bay provided by Smart City Communications or virtual Collocation Space, until Smart City Communications has provided BellSouth with the following information:
    - 7.4.1.1 For physical Central Office Collocation Space with a Smart City Communications-provided POT bay, Smart City Communications shall provide BellSouth with a complete layout of the POT panels on an Equipment Inventory Update (EIU) form that shows the locations, speeds, etc.; or
    - 7.4.1.2 For virtual Central Office Collocation Space, Smart City Communications shall

provide BellSouth with a complete layout of Smart City Communications's equipment on an EIU form, that includes the locations of the low speed ports and the specific frame terminations to which the equipment will be wired by Smart City Communications's BellSouth Certified Supplier.

- 7.4.2 BellSouth cannot begin work on the CFAs until the complete and accurate EIU form has been received from Smart City Communications. If the EIU form is provided within ten (10) days prior to the ending date of the Provisioning Interval, then the CFAs will be made available by the ending date of the Provisioning Interval. If the EIU form is not received ten (10) days prior to the ending date of the Provisioning Interval, then the CFAs will be provided within ten (10) days of BellSouth's receipt of the EIU form.
- 7.4.3 BellSouth will bill Smart City Communications a nonrecurring charge, as set forth in Exhibit B, each time Smart City Communications requests a resend of its original CFA information for any reason other than a BellSouth error in the CFAs initially provided to Smart City Communications.
- 7.5 Use of BellSouth Certified Supplier. Smart City Communications shall select a supplier which has been approved as a BellSouth Certified Supplier to perform all engineering and installation work. Smart City Communications, if a BellSouth Certified Supplier or Smart City Communications's BellSouth Certified Supplier must follow and comply with all of BellSouth's specifications and the following BellSouth Technical Requirements: TR 73503, TR 73519, TR 73572 and TR 73564. Unless the BellSouth Certified Supplier has met the requirements for all of the required work activities, Smart City Communications must use a different BellSouth Certified Supplier for the work activities associated with transmission equipment, switching equipment and power equipment. BellSouth shall provide Smart City Communications with a list of BellSouth Certified Suppliers, upon request. Smart City Communications, if a BellSouth Certified Supplier, or Smart City Communications's BellSouth Certified Supplier(s) shall be responsible for installing Smart City Communications's equipment and associated components, extending power cabling to the BellSouth power distribution frame, performing operational tests after installation is complete, and notifying BellSouth's equipment engineers and Smart City Communications upon successful completion of the installation and any associated work. When a BellSouth Certified Supplier is used by Smart City Communications, the BellSouth Certified Supplier shall bill Smart City Communications directly for all work performed for Smart City Communications pursuant to this Attachment. BellSouth shall have no liability for nor responsibility to pay, such charges imposed by Smart City Communications's BellSouth Certified Supplier. BellSouth shall make available its supplier certification program to Smart City Communications or any supplier proposed by Smart City Communications and will not unreasonably withhold certification. All work performed by or for Smart City Communications shall conform to generally accepted industry standards.
- 7.6 Alarms and Monitoring. BellSouth shall place environmental alarms in the BellSouth Premises for the protection of BellSouth equipment and facilities.

Smart City Communications shall be responsible for the placement, monitoring and removal of environmental and equipment alarms used to service Smart City Communications's Collocation Space. Upon request, BellSouth will provide Smart City Communications with an applicable BellSouth tariffed service(s) to facilitate remote monitoring of collocated equipment by Smart City Communications. Both Parties shall use best efforts to notify the other of any verified environmental condition (e.g., temperature extremes or excess humidity) known to that Party.

7.7 Virtual to Physical Relocation. In the event physical Collocation Space was previously denied at a BellSouth Central Office due to technical reasons or space limitations and physical Collocation Space has subsequently become available, Smart City Communications may relocate its existing virtual Collocation arrangement(s) to a physical Collocation arrangement(s) and pay the appropriate fees associated with the rearrangement or reconfiguration of the services being terminated into the virtual Collocation arrangement, as set forth in Exhibit B. If BellSouth knows when additional physical Collocation Space may become available at the BellSouth Central Office requested by Smart City Communications, such information will be provided to Smart City Communications in BellSouth's written denial of physical Collocation Space. Smart City Communications must arrange with a BellSouth Certified Supplier for the relocation of equipment from a virtual Collocation Space to a physical Collocation Space and will bear the cost of such relocation, including the costs associated with moving the services from the virtual Collocation Space to the new physical Collocation Space.

7.8 Virtual to Physical Conversion (In-Place)

7.8.1 Virtual collocation arrangements in Central Offices may be converted to "in-place" physical caged collocation arrangements if the potential conversion meets all of the following criteria: (1) there is no change in the amount of equipment or the configuration of the equipment that was in the virtual Collocation Space; (2) the conversion of the virtual collocation arrangement will not cause the equipment or the results of that conversion to be located in a space that BellSouth has reserved for its own future needs; and (3) any changes to the arrangement can be accommodated by existing power, HVAC, and other requirements. Unless otherwise specified herein, BellSouth will complete virtual to physical Collocation Space conversions (in-place) within sixty (60) days from receipt of the BFFO. BellSouth will bill Smart City Communications an Administrative Only Application Fee, as set forth in Exhibit B, on the date BellSouth provides an Application Response to Smart City Communications.

7.9 Cancellation. Unless otherwise specified in this Attachment, if at any time prior to Space Acceptance, Smart City Communications cancels its order for Collocation Space (Cancellation), BellSouth will bill the applicable nonrecurring charge(s) for any and all work processes for which work has begun or been completed. In Florida, if Smart City Communications cancels its order for Collocation Space at any time prior to the Space Ready Date, no cancellation fee

shall be assessed by BellSouth; however, Smart City Communications will be responsible for reimbursing BellSouth for any costs specifically incurred by BellSouth on behalf of Smart City Communications up to the date that the written notice of cancellation was received by BellSouth.

- 7.10 Licenses. Smart City Communications, at its own expense, will be solely responsible for obtaining from governmental authorities, and any other appropriate agency, entity, or person, all rights, privileges, permits, licenses and certificates necessary or required to operate as a provider of telecommunications services to the public or to build-out, equip and/or occupy Collocation Space in a BellSouth Premises.
- 7.11 Environmental Compliance. The Parties agree to utilize and adhere to the Environmental Hazard Guidelines identified in Exhibit A attached hereto.
- 8 Rates and Charges**
- 8.1 Rates. Smart City Communications agrees to pay the rates and charges identified in Exhibit B attached hereto.
- 8.1.1 Should Smart City Communications elect to transition to the TRA Option after the execution of this Agreement, Smart City Communications shall notify BellSouth in writing sixty (60) days prior to the implementation of this election.
- 8.2 Application Fees. BellSouth shall assess any nonrecurring application fees within thirty (30) days of the date that BellSouth provides an Application Response to Smart City Communications or on Smart City Communications's next scheduled monthly billing statement.
- 8.3 Recurring Charges
- 8.3.1 If Smart City Communications has met the applicable fifteen (15) day acceptance walk through interval specified in Section 4.2 above, billing for recurring charges will begin upon the Space Acceptance Date. In the event Smart City Communications fails to complete an acceptance walk through within the applicable fifteen (15) day interval, billing for recurring charges will commence on the Space Ready Date. If Smart City Communications occupies the space prior to the Space Ready Date, the date Smart City Communications occupies the space is deemed the Space Acceptance Date and billing for recurring charges will begin on that date. The billing for all applicable monthly recurring charges will begin in Smart City Communications's next billing cycle and will include any prorated charges for the period from Smart City Communications's Space Acceptance Date or Space Ready Date, whichever is appropriate pursuant to Section 4.2 above, to the date the bill is issued by BellSouth.
- 8.3.2 Unless otherwise stated in Section 8.6 below, monthly recurring charges for -48V DC power will be assessed per fused ampere (amp), per month, based upon the total number of fused amps of power capacity requested by Smart City Communications on Smart City Communications's Initial Collocation Application and all Subsequent Collocation Applications, which may either

increase or decrease the originally requested, and any subsequently augmented, number of fused amps of power capacity requested, consistent with Commission orders.

- 8.3.3 BellSouth shall have the right to inspect and inventory any DC power fuse installations at a BellSouth BDFB or DC power circuit installations at BellSouth's main power board for any Smart City Communications collocation arrangement, to verify that the total number of fused amps of power capacity installed by Smart City Communications's BellSouth Certified Supplier matches the number of fused amps of DC power capacity requested by Smart City Communications on Smart City Communications's Initial Application and all Subsequent Applications. If BellSouth determines that Smart City Communications's BellSouth Certified Supplier has installed more DC capacity than Smart City Communications requested on its Initial Application and all Subsequent Applications, BellSouth shall notify Smart City Communications in writing of such discrepancy and shall assess Smart City Communications for the additional DC power fuse/circuit capacity from the Space Acceptance Date or Space Ready Date, whichever is applicable pursuant to Section 8.3.1 above, for the most recent Initial Application or Subsequent Application, submitted for such collocation arrangement. BellSouth shall also revise Smart City Communications's recurring DC power charges, on a going-forward basis, to reflect the higher number of fused amps of power capacity available for the collocation arrangement.
- 8.4 Nonrecurring Charges. Unless specified otherwise herein, BellSouth shall assess nonrecurring charges, including all application fees, within thirty (30) days of the date that BellSouth provides an Application Response to Smart City Communications or on Smart City Communications's next scheduled monthly billing statement, if Smart City Communications's current month's billing cycle has already closed. Nonrecurring charges associated with the processing of the Firm Order for collocation space preparation (Firm Order Processing Fee) shall be billed by BellSouth within thirty (30) days of BellSouth's confirmation of Smart City Communications's BFFO or on Smart City Communications's next scheduled monthly billing statement.
- 8.5 In some cases, Commissions have ordered BellSouth to separate its disconnect costs and its installation costs into two separate nonrecurring charges. Accordingly, unless otherwise noted in this Agreement, the Commission ordered disconnect charges will be applied at the time the disconnect activity is performed by BellSouth, regardless of whether or not a disconnect order is issued by Smart City Communications. Disconnect charges are set forth in Exhibit B of this Attachment.
- 8.6 Central Office Space Preparation. Space preparation fees consist of a nonrecurring charge for Firm Order Processing and monthly recurring charges for Central Office Modifications and Common Systems Modifications. For all states except Florida, Smart City Communications shall remit the payment of the nonrecurring Firm Order Processing Fee coincident with the submission of Smart City Communications's BFFO. In Florida, the nonrecurring Firm Order

Processing Fee will be billed by BellSouth, pursuant to Section 8.4 above. The monthly recurring charge for Central Office Modifications will be assessed per arrangement, per square foot, for both caged and cageless physical Collocation Space. The monthly recurring charge for Common Systems Modifications will be assessed per arrangement, per square foot for cageless physical Collocation Space and on a per cage basis for caged physical Collocation Space. These charges recover the costs associated with preparing the Collocation Space, which includes, but is not limited to, the following items: a survey, engineering of the Collocation Space, and design and modification costs for network, building and support systems.

8.7 Central Office Floor Space. The Floor Space Charge includes reasonable charges for lighting, HVAC, and other allocated expenses associated with maintenance of the BellSouth Premises; however, this charge does not include any expenses associated with AC or DC power supplied to Smart City Communications's Collocation Space for the operation of Smart City Communications's equipment. For caged physical Collocation Space, Smart City Communications shall pay floor space charges based upon the number of square feet enclosed. The minimum size for caged Collocation Space is fifty (50) square feet. Additional caged Collocation Space may be requested in increments of fifty (50) square feet. For cageless Collocation Space, Smart City Communications shall pay floor space charges based upon the following floor space calculation: [(depth of the equipment lineup in which the rack is placed) + (0.5 x maintenance aisle depth) + (0.5 x wiring aisle depth)] x (width of rack and spacers). For purposes of this calculation, the depth of the equipment lineup shall consider the footprint of equipment racks plus any equipment overhang. BellSouth will assign cageless Collocation Space in conventional equipment rack lineups where feasible. In the event Smart City Communications's collocated equipment requires special cable racking, an isolated ground plane, or any other considerations and treatment which prevents placement within conventional equipment rack lineups, Smart City Communications shall be required to request an amount of floor space sufficient to accommodate the total equipment arrangement.

8.8 Remote Site Bay Space. In a Remote Site, the bay space charge recovers the costs associated with air conditioning, ventilation and other allocated expenses for the maintenance of the Remote Site Location, and includes the amperage necessary to power Smart City Communications's equipment. Smart City Communications shall remit bay space charges based upon the number of bays requested. BellSouth will assign Remote Site Collocation Space in conventional Remote Site bay lineups where feasible.

8.9 Power

8.9.1 In a Central Office BellSouth shall make available -48V DC power for Smart City Communications's Collocation Space at a BellSouth BDFB. When obtaining DC power from a BellSouth BDFB, Smart City Communications's fuses and power cables (for the A & B feeds) must be engineered (sized), and installed by Smart City Communications's BellSouth Certified Supplier, in accordance with the

number of fused amps of DC power requested by Smart City Communications on Smart City Communications's Initial Application and any Subsequent Applications. Smart City Communications is also responsible for contracting with a BellSouth Certified Supplier to run the power distribution feeder cable from the BellSouth BDFB to the equipment in Smart City Communications's Collocation Space. The BellSouth Certified Supplier contracted by Smart City Communications must provide BellSouth with a copy of the engineering power specifications prior to the day on which Smart City Communications's equipment becomes operational (hereinafter "Commencement Date"). BellSouth will provide the common power feeder cable support structure between the BellSouth BDFB and Smart City Communications's Collocation Space. Smart City Communications shall contract with a BellSouth Certified Supplier who shall be responsible for performing those power provisioning activities required to enable Smart City Communications's equipment to become operational, which may include, but are not limited to, the installation, removal or replacement of the following: dedicated power cable support structure within Smart City Communications's Collocation Space, power cable feeds and terminations of the power cabling. Smart City Communications and Smart City Communications's BellSouth Certified Supplier shall comply with all applicable NEC, BellSouth TR 73503, Telcordia and ANSI Standards that address power cabling, installation and maintenance.

- 8.9.1.1 At a Remote Site, BellSouth shall make available -48V DC power for Smart City Communications's Remote Collocation Space at a BDFB within the Remote Site Location. The charge for power shall be assessed as part of the recurring charge for bay space, as referenced in Section 8.7 above. If the power requirements for Smart City Communications's equipment exceed the capacity available, then such additional power requirements shall be assessed on an individual case basis.
- 8.9.2 In Florida Central Offices only, subject to technical feasibility, commercial availability and safety limitations, BellSouth will permit Smart City Communications to request DC power in five (5) amp increments from five (5) amps up to one hundred (100) amps from the BellSouth BDFB. However, in accordance with industry standard fuse sizing, Smart City Communications may request that BellSouth provision DC power of seventy (70) amps or greater directly from BellSouth's main power board. The industry standard fuse size (which is a circuit breaker on the main power board) available at a BellSouth main power board in all BellSouth Premises is a two hundred twenty-five (225) amp circuit breaker.
- 8.9.3 BellSouth will revise Smart City Communications's Central Office recurring power charges, in accordance with Section 8.3 above, to reflect a power upgrade when Smart City Communications submits a Subsequent Application requesting an increase in the number of fused amps it is currently receiving from BellSouth for its Collocation Space. If Smart City Communications's existing fuses and power cables (for the A&B power feed) are not sufficient to support the additional number of fused amps requested, Smart City Communications's BellSouth



Certified Supplier shall perform whatever activities are necessary, which may include the installation of new/additional fuses or power cables, to comply with the appropriate NEC, BellSouth TR 73503, Telcordia and ANSI Standards, as well as the requirements noted in Sections 8.7 and 8.7.1 above. Smart City Communications's BellSouth Certified Supplier shall provide notification to BellSouth when these activities have been completed.

- 8.9.4 BellSouth will revise Smart City Communications's Central Office recurring power charges, in accordance with Section 8.3 above, to reflect a power reduction upon BellSouth's receipt of the Power Reduction Form from Smart City Communications, certifying the completion of the power reduction work, including the removal of any associated power cabling by Smart City Communications's BellSouth Certified Supplier. Notwithstanding the foregoing, if Smart City Communications's BellSouth Certified Supplier has not removed or, at BellSouth's discretion, cut the power cabling within thirty (30) days, the power reduction will not become effective until the cabling is removed or, at BellSouth's discretion, cut by Smart City Communications's BellSouth Certified Supplier and Smart City Communications shall pay for the amount of power that had been requested prior to the power reduction request for the period up to the date the power cabling is actually removed.
- 8.9.5 If Smart City Communications requests an increase or a reduction in the amount of power that BellSouth is currently providing in a Central Office, Smart City Communications must submit a Subsequent Application. In all states other than Florida if no modification to the Collocation Space is requested other than the increase or reduction in power, the Simple Augment fee will apply. In Florida the Power Reconfiguration Only Application Fee as set forth in Exhibit B will apply. If modifications are requested in addition to the increase or reduction of power, the Subsequent Application Fee will apply. BellSouth will bill this nonrecurring fee on the date that BellSouth provides an Application Response to Smart City Communications's Subsequent Application.
- 8.9.6 If Smart City Communications elects to install its own DC Power Plant, BellSouth shall provide AC power to feed Smart City Communications's DC Power Plant. Charges for AC power will be assessed on a per breaker ampere, per month basis, pursuant to the rates specified in Exhibit B. The AC power rates include recovery for the provision of commercial and standby AC power. When obtaining power from a BellSouth service panel, protection devices and power cables must be engineered (sized) and installed by Smart City Communications's BellSouth Certified Supplier, with the exception that BellSouth shall engineer and install protection devices and power cables for Adjacent Collocation. Smart City Communications's BellSouth Certified Supplier must provide a copy of the engineering power specifications prior to the Commencement Date. AC power voltage and phase ratings shall be determined on a per location basis. At Smart City Communications's option, Smart City Communications may arrange for AC power in an adjacent collocation arrangement from a retail provider of electrical power.

8.9.7 Smart City Communications shall contract with a BellSouth Certified Supplier to perform the installation and removal of dedicated power cable support structure within Smart City Communications's arrangement and terminations of cable within the Collocation Space.

8.9.8 Fused Amp Power. In all states, except as otherwise set forth in this Agreement, BellSouth shall make available -48V DC power on a per fused amp, per month basis, pursuant to the following:

For power provisioned from a BDFB. The number of fused amps requested by Smart City Communications on its collocation application for power that is being provisioned from a BellSouth BDFB will be multiplied by the DC power fused amp rate set forth in Exhibit B. A minimum of ten (10) fused amps is required.

For existing power configurations that are provisioned from BellSouth's main power board. The number of fused amps made available at the main power board, in increments of two hundred and twenty-five (225) amps/main power board circuit, will be multiplied by the DC power fused amp rate set forth in Exhibit B.

8.9.9 Florida Power Usage Option

8.9.9.1 In Central Offices in Florida only, Smart City Communications may request that -48 DC power provisioned by BellSouth to Smart City Communications's Collocation Space be assessed per amp, per month based upon amps used, pursuant to the rates set forth in Exhibit B. Monthly recurring power charges will be assessed on the Space Acceptance Date or Space Ready Date, whichever is appropriate, pursuant to Section 8.3 above. If Smart City Communications desires to convert existing physical collocation arrangements to the Florida Power Usage Option (hereinafter "FL Option"), then the monthly recurring power charges that are applicable to the FL Option, contained in Exhibit B, will be assessed on the Space Ready Date associated with the Subsequent Application submitted by Smart City Communications to convert an existing collocation arrangement to the FL Option. The monthly recurring charges for DC power, under the FL Option, shall be calculated and applied based on the amount of power Smart City Communications requests that it be allowed to draw at a given time to a specific physical collocation arrangement in a particular BellSouth Premises on Smart City Communications's Initial Application or Subsequent Application. BellSouth shall allow Smart City Communications at Smart City Communications's option, to order a power feed that is capable of delivering a higher DC power level but to fuse this power feed so as to allow a power level less than the feed's maximum to be drawn by Smart City Communications. BellSouth is not required to build its central office power infrastructure to meet Smart City Communications's forecasted DC power demand. Smart City Communications must specify on its Initial or Subsequent Application the power level it wishes to be able to draw from BellSouth's power plant for each existing collocation arrangement Smart City Communications converts to the FL Option

or for any new collocation arrangements Smart City Communications establishes under the FL Option.

- 8.9.9.2 BellSouth, at any time and at its own expense, shall have the right to verify the accuracy of Smart City Communications's power usage under the FL Option for a specific collocation arrangement in a particular BellSouth Premises, based on a meter reading(s) taken by BellSouth of the amount of power being consumed by Smart City Communications's collocation arrangement. BellSouth may perform its own meter reading(s) via any method it chooses, such as, but not limited to, a clamp-on ammeter. If the meter reading(s) varies by more than ten percent (10%) or five (5) amps from the power usage that has been requested by Smart City Communications for the collocation arrangement, under the FL Option, the Parties agree to work cooperatively to reconcile such discrepancy and establish the appropriate usage figure in a reasonable and expeditious manner. If the Parties substantiate BellSouth's reading, then BellSouth shall adjust Smart City Communications's billing to reflect BellSouth's power reading beginning with the first day of the month immediately following the date of the last metered reading taken by BellSouth.
- 8.9.9.3 BellSouth shall assess Smart City Communications a monthly recurring charge for DC power under the FL Option, as set forth in Exhibit B. Smart City Communications shall notify BellSouth of any change in its DC power usage by submitting a Subsequent Application, which reflects the new DC power level desired by Smart City Communications. The requested change in DC power usage will be reflected in Smart City Communications's next scheduled monthly billing cycle.
- 8.9 Central Office Cable Installation. Cable Installation fees will be assessed on a per entrance cable basis. This nonrecurring charge will be billed by BellSouth upon receipt of Smart City Communications's BFFO. Charges for cable racking, cable support structure and entrance fiber structure are recurring fees and will also be assessed according to the rates set forth in Exhibit B.
- 8.10 Central Office Cable Records. Cable Records charges apply for work activities required to build or remove existing cable records assigned to Smart City Communications in BellSouth's database systems. The VG/DSO per cable record charge is for a maximum of thirty-six hundred (3,600) records per request. The fiber cable record charge is for a maximum of ninety-nine (99) records per request. Cable Record fees will be assessed as a nonrecurring charge, upon receipt of Smart City Communications's BFFO, in all BellSouth states. All charges will be assessed the rates set forth in Exhibit B.
- 8.11 Security Escort. After Smart City Communications has used its one (1) accompanied site visit, pursuant to Section 5.12.1 above, and prior to Smart City Communications's completion of the BellSouth Security Training requirements, contained in Section 12 below, a security escort will be required when Smart City Communications's employees, approved agent, supplier, or Guest(s) desire access to the entrance manhole or a BellSouth Premises. The rates for security escort

service are assessed pursuant to the fee schedule contained in Exhibit B, beginning with the scheduled escort time agreed to by the Parties. BellSouth will wait for one-half (1/2) hour after the scheduled escort time to provide such requested escort service and Smart City Communications shall pay for such half-hour charges in the event Smart City Communications's employees, approved agent, supplier or Guest(s) fails to show up for the scheduled escort appointment.

- 8.12 Other. If no collocation rate element and associated rate is identified in Exhibit B, the Parties, upon request by either Party, will negotiate the rate for the specific collocation service or function identified in this Attachment.

## **9 Insurance**

- 9.1 Smart City Communications shall, at its sole cost and expense, procure, maintain, and keep in force insurance as specified in this Section and underwritten by insurance companies licensed to do business in the states applicable under this Agreement and having a Best's Insurance Rating of A.
- 9.2 Smart City Communications shall maintain the following specific coverage:
- 9.2.1 Commercial General Liability coverage in the amount of ten million dollars (\$10,000,000) or a combination of Commercial General Liability and Excess/Umbrella coverage totaling not less than ten million dollars (\$10,000,000). BellSouth shall be named as an Additional Insured on the Commercial General Liability policy as specified herein.
- 9.2.2 Statutory Workers Compensation coverage and Employers Liability coverage in the amount of one hundred thousand dollars (\$100,000) each accident, one hundred thousand dollars (\$100,000) each employee by disease, and five hundred thousand dollars (\$500,000) policy limit by disease.
- 9.2.3 All Risk Property coverage on a full replacement cost basis insuring all of Smart City Communications's real and personal property situated on or within a BellSouth Premises.
- 9.2.4 Smart City Communications may elect to purchase business interruption and contingent business interruption insurance, having been advised that BellSouth assumes no liability for loss of profit or revenues should an interruption of service occur.
- 9.3 The limits set forth in Section 9.2 above may be increased by BellSouth from time to time during the term of this Agreement, upon thirty (30) days notice to Smart City Communications, to at least such minimum limits as shall then be customary with respect to comparable occupancy of BellSouth structures.
- 9.4 All policies purchased by Smart City Communications shall be deemed to be primary and not contributing to or in excess of any similar coverage purchased by BellSouth. All insurance must be in effect on or before the date equipment is delivered to BellSouth's Premises and shall remain in effect for the term of this Agreement or until all of Smart City Communications's property has been

removed from BellSouth's Premises, whichever period is longer. If Smart City Communications fails to maintain required coverage, BellSouth may pay the premiums thereon and seek reimbursement of same from Smart City Communications.

- 9.5 Smart City Communications shall submit certificates of insurance reflecting the coverage required pursuant to this Section within a minimum of ten (10) business days prior to the commencement of any work in the Collocation Space. Failure to meet this interval may result in construction and equipment installation delays. Smart City Communications shall arrange for BellSouth to receive thirty (30) business days' advance notice of cancellation or non-renewal from Smart City Communications's insurance company. Smart City Communications shall forward a certificate of insurance and notice of cancellation/non-renewal to BellSouth at the following address:

BellSouth Telecommunications, Inc.  
Attn: Risk Management Office – Finance  
17F54 BellSouth Center  
675 W. Peachtree Street  
Atlanta, GA 30375

- 9.6 Smart City Communications must conform to recommendations made by BellSouth's fire insurance company to the extent BellSouth has agreed to, or shall hereafter agree to, such recommendations.

- 9.7 Self Insurance. If Smart City Communications's net worth exceeds five hundred million dollars (\$500,000,000), Smart City Communications may elect to request self-insurance status in lieu of obtaining any of the insurance required in Section 9.2 above. Smart City Communications shall provide audited financial statements to BellSouth thirty (30) days prior to the commencement of any work in the Collocation Space. BellSouth shall then review such audited financial statements and respond in writing to Smart City Communications in the event that self-insurance status is not granted to Smart City Communications. If BellSouth approves Smart City Communications for self-insurance, Smart City Communications shall annually furnish to BellSouth, and keep current, evidence of such net worth that is attested to by one of Smart City Communications's corporate officers. The ability to self-insure shall continue so long as Smart City Communications meets all of the requirements of this Section. If Smart City Communications subsequently no longer satisfies the requirements of this Section, Smart City Communications is required to purchase insurance as indicated by Section 9.2 above.

- 9.8 The net worth requirements set forth in Section 9.7 above may be increased by BellSouth from time to time during the term of this Agreement upon thirty (30) days' notice to Smart City Communications to at least such minimum limits as shall then be customary with respect to comparable occupancy of a BellSouth Premises.

- 9.9 Failure to comply with the provisions of this Section will be deemed a material

breach of this Attachment.

## **10 Mechanics Lien**

- 10.1 If any mechanics lien or other liens are filed against property of either Party (BellSouth or Smart City Communications), or any improvement thereon by reason of or arising out of any labor or materials furnished or alleged to have been furnished or to be furnished to or for the other Party or by reason of any changes, or additions to said property made at the request or under the direction of the other Party, the other Party directing or requesting those changes shall, within thirty (30) business days after receipt of written notice from the Party against whose property said lien has been filed, either pay such lien or cause the same to be bonded off the affected property in the manner provided by law. The Party causing said lien to be placed against the property of the other shall also defend at its sole cost and expense, on behalf of the other, any action, suit or proceeding which may be brought for the enforcement of such liens and shall pay any damage and discharge any judgment entered thereon.

## **11 Inspections**

- 11.1 BellSouth may conduct an inspection of Smart City Communications's equipment and facilities in Smart City Communications's Collocation Space(s) prior to the activation of facilities and/or services between Smart City Communications's equipment and equipment of BellSouth. BellSouth may conduct an inspection if Smart City Communications adds equipment and may otherwise conduct routine inspections at reasonable intervals mutually agreed upon by the Parties. BellSouth shall provide Smart City Communications with a minimum of forty-eight (48) hours or two (2) business days, whichever is greater, advance notice of all such inspections. All costs of such inspections shall be borne by BellSouth.

## **12 Security and Safety Requirements**

- 12.1 Unless otherwise specified, Smart City Communications will be required, at its own expense, to conduct a statewide investigation of criminal history records for each Smart City Communications employee hired in the past five (5) years being considered for work on a BellSouth Premises, for the states/counties where the Smart City Communications employee has worked and lived for the past five (5) years. Where state law does not permit statewide collection or reporting, an investigation of the applicable counties is acceptable. Smart City Communications shall not be required to perform this investigation if an affiliated company of Smart City Communications has performed an investigation of the Smart City Communications employee seeking access, if such investigation meets the criteria set forth above. This requirement will not apply if Smart City Communications has performed a pre-employment statewide investigation of criminal history records of the Smart City Communications employee for the states/counties where the Smart City Communications employee has worked and lived for the past five (5) years or, where state law does not permit a statewide investigation, an investigation of the applicable counties.

- 12.2 Smart City Communications will be required to administer to its personnel assigned to the BellSouth Premises security training either provided by BellSouth, or meeting criteria defined by BellSouth at BellSouth's Interconnection Web site, [www.interconnection.bellsouth.com/guides](http://www.interconnection.bellsouth.com/guides).
- 12.3 Smart City Communications shall provide its employees and agents with picture identification, which must be worn and visible at all times while in Smart City Communications's Collocation Space or other areas in or around the BellSouth Premises. The photo identification card shall bear, at a minimum, the employee's name and photo and Smart City Communications's name. BellSouth reserves the right to remove from a BellSouth Premises any employee of Smart City Communications not possessing identification issued by Smart City Communications or who has violated any of BellSouth's policies as outlined in the CLEC Security Training documents. Smart City Communications shall hold BellSouth harmless for any damages resulting from such removal of Smart City Communications's personnel from a BellSouth Premises. Smart City Communications shall be solely responsible for ensuring that any Guest(s) of Smart City Communications is in compliance with all subsections of this Section.
- 12.4 Smart City Communications shall not assign to the BellSouth Premises any personnel with records of felony criminal convictions. Smart City Communications shall not assign to the BellSouth Premises any personnel with records of misdemeanor convictions, except for misdemeanor traffic violations, without advising BellSouth of the nature and gravity of the offense(s). BellSouth reserves the right to refuse building access to any of Smart City Communications's personnel who have been identified to have misdemeanor criminal convictions. Notwithstanding the foregoing, in the event Smart City Communications chooses not to advise BellSouth of the nature and gravity of any misdemeanor conviction, Smart City Communications may, in the alternative, certify to BellSouth that it shall not assign to the BellSouth Premises any personnel with records of misdemeanor convictions (other than misdemeanor traffic violations).
- 12.4.1 Smart City Communications shall not knowingly assign to the BellSouth Premises any individual who was a former employee of BellSouth and whose employment with BellSouth was terminated for a criminal offense, whether or not BellSouth sought prosecution of the individual for the criminal offense.
- 12.4.2 Smart City Communications shall not knowingly assign to the BellSouth Premises any individual who was a former supplier of BellSouth and whose access to a BellSouth Premises was revoked due to the commission of a criminal offense, whether or not BellSouth sought prosecution of the individual for the criminal offense.
- 12.5 For each Smart City Communications employee or agent hired by Smart City Communications within the last five (5) years, who requires access to a BellSouth Premises to perform work in Smart City Communications Collocation Space(s), Smart City Communications shall furnish BellSouth certification that the

aforementioned background check and security training were completed. This certification must be provided to and approved by BellSouth before an employee or agent will be granted such access to a BellSouth Premises. The certification will contain a statement that no felony convictions were found and certify that the employee completed the security training. If the employee's criminal history includes misdemeanor convictions, Smart City Communications will disclose the nature of the convictions to BellSouth at that time. In the alternative, Smart City Communications may certify to BellSouth that it shall not assign to the BellSouth Premises any personnel with records of misdemeanor convictions, other than misdemeanor traffic violations.

- 12.5.1 For all other Smart City Communications employees requiring access to a BellSouth Premises pursuant to this Attachment, Smart City Communications shall furnish BellSouth, prior to an employee gaining such access, a certification that the employee is not subject to the requirements of Section 12.5 above and that security training was completed by the employee.
- 12.6 At BellSouth's request, Smart City Communications shall promptly remove from the BellSouth Premises any employee of Smart City Communications that BellSouth does not wish to grant access to a BellSouth Premises: 1) pursuant to any investigation conducted by BellSouth, or 2) prior to the initiation of an investigation if an employee of Smart City Communications is found interfering with the property or personnel of BellSouth or another collocated telecommunications carrier, provided that an investigation shall be promptly commenced by BellSouth.
- 12.7 Security Violations. BellSouth reserves the right to interview Smart City Communications's employees, agents, suppliers, or Guests in the event of wrongdoing in or around a BellSouth Premises or involving BellSouth's or another collocated telecommunications carrier's property or personnel, provided that BellSouth shall provide reasonable notice to Smart City Communications's Security representative of such interview. Smart City Communications and its employees, agents, suppliers, or Guests shall reasonably cooperate with BellSouth's investigation into allegations of wrongdoing or criminal conduct committed by, witnessed by, or involving Smart City Communications's employees, agents, suppliers, or Guests. Additionally, BellSouth reserves the right to bill Smart City Communications for all reasonable costs associated with investigations involving its employees, agents, suppliers, or Guests if it is established and mutually agreed in good faith that Smart City Communications's employees, agents, suppliers, or Guests are responsible for the alleged act(s). BellSouth shall bill Smart City Communications for BellSouth property, which is stolen or damaged, where an investigation determines the culpability of Smart City Communications's employees, agents, suppliers, or Guests and where Smart City Communications agrees, in good faith, with the results of such investigation. Smart City Communications shall notify BellSouth in writing immediately in the event that Smart City Communications discovers one of its employees, agents, suppliers, or Guests already working on the BellSouth Premises is a possible



security risk. Upon request of the other Party, the Party who is the employer shall discipline consistent with its employment practices, up to and including removal from BellSouth's Premises, any employee found to have violated the security and safety requirements of this Section. Smart City Communications shall hold BellSouth harmless for any damages resulting from such removal of Smart City Communications's personnel from a BellSouth Premises.

12.8 Use of Supplies. Unauthorized use of equipment, supplies or other property by either Party, whether or not used routinely to provide telephone service will be strictly prohibited and handled appropriately. Costs associated with such unauthorized use may be charged to the offending Party, as may be all associated investigative costs.

12.9 Use of Official Lines. Except for non-toll calls necessary in the performance of their work, neither Party shall use the telephone(s) of the other Party on BellSouth's Premises. Charges for unauthorized telephone calls may be charged to the offending Party, as may be all associated investigative costs.

12.10 Accountability. Full compliance with the Security requirements of this Section shall in no way limit the accountability of either Party to the other for the improper actions of its employees, agents, suppliers, or Guests.

### **13 Destruction of Collocation Space**

13.1 In the event a Collocation Space is wholly or partially damaged by fire, windstorm, hurricane, tornado, flood or by similar force majeure circumstances to such an extent as to be rendered wholly unsuitable for Smart City Communications's permitted use hereunder, then either Party may elect within ten (10) days after such damage, to terminate occupancy of the damaged Collocation Space, and if either Party shall so elect, by giving the other written notice of termination, both Parties shall stand released of and from further liability under the terms hereof. If the Collocation Space shall suffer only minor damage and shall not be rendered wholly unsuitable for Smart City Communications's permitted use, or is damaged and the option to terminate is not exercised by either Party, BellSouth covenants and agrees to proceed promptly without expense to Smart City Communications, except for improvements not to the property of BellSouth, to repair the damage. BellSouth shall have a reasonable time within which to rebuild or make any repairs, and such rebuilding and repairing shall be subject to delays caused by storms, shortages of labor and materials, government regulations, strikes, walkouts, and causes beyond the control of BellSouth, which causes shall not be construed as limiting factors, but as exemplary only. Smart City Communications may, at its own expense, accelerate the rebuild of its Collocation Space and equipment provided, however, that a BellSouth Certified Supplier is used and the necessary space preparation has been completed. If Smart City Communications's acceleration of the project increases the cost of the project, then those additional charges will be incurred at Smart City Communications's expense. Where allowed and where practical, Smart City Communications may erect a temporary facility while BellSouth rebuilds or

makes repairs. In all cases where the Collocation Space shall be rebuilt or repaired, Smart City Communications shall be entitled to an equitable abatement of rent and other charges, depending upon the unsuitability of the Collocation Space for Smart City Communications's permitted use, until such Collocation Space is fully repaired and restored and Smart City Communications's equipment installed therein (but in no event later than thirty (30) days after the Collocation Space is fully repaired and restored). Where Smart City Communications has placed an Adjacent Arrangement pursuant to Section 3.4 above, Smart City Communications shall have the sole responsibility to repair or replace said Adjacent Arrangement provided herein. Pursuant to this Section, BellSouth will restore the associated services to the Adjacent Arrangement.

**14 Eminent Domain**

- 14.1 If the whole of a Collocation Space or Adjacent Arrangement shall be taken by any public authority under the power of eminent domain, then this Attachment shall terminate with respect to such Collocation Space or Adjacent Arrangement as of the date possession shall be taken by such public authority and rent and other charges for the Collocation Space or Adjacent Arrangement shall be paid up to that day with a proportionate refund by BellSouth of such rent and charges as may have been paid in advance for a period subsequent to the date of the taking. If any part of the Collocation Space or Adjacent Arrangement shall be taken under eminent domain, BellSouth and Smart City Communications shall each have the right to terminate this Attachment with respect to such Collocation Space or Adjacent Arrangement and declare the same null and void, by written notice of such intention to the other Party within ten (10) days after such taking.

**15 Nonexclusivity**

- 15.1 Smart City Communications understands that this Attachment is not exclusive and that BellSouth may enter into similar agreements with other Parties. Assignment of Collocation Space pursuant to all such agreements shall be determined by space availability and made on a first come, first serve basis.

## ENVIRONMENTAL AND SAFETY PRINCIPLES

The following principles provide basic guidance on environmental and safety issues when applying for and establishing physical collocation arrangements.

### 1. General Principles

- 1.1 Compliance with Applicable Law. BellSouth and Smart City Communications agree to comply with applicable federal, state, and local environmental and safety laws and regulations including U.S. Environmental Protection Agency (USEPA) regulations issued under the Clean Air Act (CAA), Clean Water Act (CWA), Resource Conservation and Recovery Act (RCRA), Comprehensive Environmental Response, Compensation and Liability Act (CERCLA), Superfund Amendments and Reauthorization Act (SARA), the Toxic Substances Control Act (TSCA), and Occupational Safety and Health Act (OSHA) regulations issued under the OSHA of 1970, as amended and National Fire Protection Association (NFPA), NEC and NESC (Applicable Laws) requirements. Each Party shall notify the other if compliance inspections are conducted by regulatory agencies and/or citations are issued that relate to any aspect of this Attachment.
- 1.2 Notice. BellSouth and Smart City Communications shall provide notice to the other, including any Material Safety Data Sheets (MSDSs), of known and recognized physical hazards or Hazardous Chemicals existing on site or brought on site. A Hazardous Chemical inventory list is posted on an OSHA Poster and updated annually at each Central Office. This Poster is normally located near the front entrance of the building or in the lounge area. Each Party is required to provide specific notice for known potential Imminent Danger conditions. Smart City Communications should contact 1-800-743-6737 for any BellSouth MSDS required.
- 1.3 Practices/Procedures. BellSouth may make available additional environmental control procedures for Smart City Communications to follow when working at a BellSouth Premises (See Section 2, below). These practices/procedures will represent the regular work practices required to be followed by the employees and suppliers of BellSouth for environmental protection. Smart City Communications will require its suppliers, agents, Guests, and others accessing the BellSouth Premises to comply with these practices. Section 2 below lists the Environmental categories where BellSouth practices should be followed by Smart City Communications when operating in the BellSouth Premises.
- 1.4 Environmental and Safety Inspections. BellSouth reserves the right to inspect the Smart City Communications space with proper notification. BellSouth reserves the right to stop any Smart City Communications work operation that imposes Imminent Danger to the environment, employees or other persons in or around a BellSouth Premises.
- 1.5 Hazardous Materials Brought On Site. Any hazardous materials brought into,

used, stored or abandoned at a BellSouth Premises by Smart City Communications are owned by and considered the property of Smart City Communications. Smart City Communications will indemnify BellSouth for claims, lawsuits or damages to persons or property caused by these materials. Without prior written BellSouth approval, no substantial new safety or environmental hazards can be created by Smart City Communications or different hazardous materials used by Smart City Communications at a BellSouth Premises. Smart City Communications must demonstrate adequate emergency response capabilities for the materials used by Smart City Communications or remaining at a BellSouth Premises.

- 1.6 Spills and Releases. When contamination is discovered at a BellSouth Premises, either Party discovering the condition must notify the other Party. All Spills or Releases of regulated materials will immediately be reported by Smart City Communications to BellSouth.
- 1.7 Coordinated Environmental Plans and Permits. BellSouth and Smart City Communications will coordinate plans, permits or information required to be submitted to government agencies, such as emergency response plans, spill prevention control and countermeasures (SPCC) plans and community reporting. If fees are associated with filing, BellSouth and Smart City Communications will develop a cost sharing procedure. If BellSouth's permit or EPA identification number must be used, Smart City Communications must comply with all of BellSouth's permit conditions and environmental processes, including environmental "best management practices (BMP)" (see Section 2, below) and the selection of BST disposition vendors and disposal sites.
- 1.8 Environmental and Safety Indemnification. BellSouth and Smart City Communications shall indemnify, defend and hold harmless the other Party from and against any claims (including, without limitation, third-party claims for personal injury or death or real or personal property damage), judgments, damages (including direct and indirect damages and punitive damages), penalties, fines, forfeitures, costs, liabilities, interest and losses arising in connection with the violation or alleged violation of any Applicable Law or contractual obligation or the presence or alleged presence of contamination arising out of the acts or omissions of the indemnifying Party, its employees, agents, suppliers, or Guests concerning its operations at a BellSouth Premises.

## 2. **Categories for Consideration of Environmental Issues**

- 2.1 When performing functions that fall under the following Environmental categories on BellSouth's Premises, Smart City Communications agrees to comply with the applicable sections of the current issue of BellSouth's Environmental and Safety Methods and Procedures (M&Ps), incorporated herein by this reference. Smart City Communications further agrees to cooperate with BellSouth to ensure that Smart City Communications's employees, agents, suppliers and/or Guests are knowledgeable of and satisfy those provisions of

BellSouth’s Environmental M&Ps, which apply to the specific Environmental function being performed by Smart City Communications, its employees, agents, suppliers, and/or Guests.

2.2 The most current version of the reference documentation must be requested from Smart City Communications’s BellSouth Regional Contract Manager (RCM).

<b>Environmental Categories</b>	<b>Environmental Issues</b>	<b>Addressed By The Following Documentation</b>
Disposal of hazardous material or other regulated material (e.g., batteries, fluorescent tubes, solvents & cleaning materials)	Compliance with all applicable local, state & federal laws and regulations	Std T&C 450 Fact Sheet Series 17000
	Pollution liability insurance	Std T&C 660-3
	EVET approval of supplier	Approved Environmental Vendor List (Contact RCM Representative)
Emergency response	Hazmat/waste release/spill fire safety emergency	Fact Sheet Series 17000 Building Emergency Operations Plan (EOP) (specific to and located on BellSouth’s Premises)
Contract labor/outsourcing for services with environmental implications to be performed on BellSouth Premises (e.g., disposition of hazardous material/waste; maintenance of storage tanks)	Compliance with all applicable local, state and federal laws and regulations	Std T&C 450
	Performance of services in accordance with BST’s environmental M&Ps	Std T&C 450-B (Contact RCM Representative for copy of appropriate E/S M&Ps.)
	Insurance	Std T&C 660
Transportation of hazardous material	Compliance with all applicable local, state & federal laws and regulations	Std T&C 450 Fact Sheet Series 17000
	Pollution liability insurance	Std T&C 660-3
	EVET approval of supplier	Approved Environmental Vendor List (Contact RCM Representative)
Maintenance/operations work which may produce a waste	Compliance with all applicable local, state &	Std T&C 450

Other maintenance work	federal laws and regulations  Protection of BST employees and equipment	29 C.F.R. § 1910.147 (OSHA Standard) 29 C.F.R. § 1910 Subpart O (OSHA Standard)
Janitorial service	All waste removal and disposal must conform to all applicable federal, state and local regulations  All Hazardous Material and Waste  Asbestos notification and protection of employees and equipment	Procurement Manager (CRES Related Matters)-BST Supply Chain Services  Fact Sheet Series 17000  GU-BTEN-001BT, Chapter 3 BSP 010-170-001BS (Hazcom)
Manhole cleaning	Compliance with all applicable local, state & federal laws and regulations  Pollution liability insurance  EVET approval of supplier	Std T&C 450 Fact Sheet 14050 BSP 620-145-011PR Issue A, August 1996  Std T&C 660-3  Approved Environmental Vendor List (Contact RCM Representative)
Removing or disturbing building materials that may contain asbestos	Asbestos work practices	GU-BTEN-001BT, Chapter 3 for questions regarding removing or disturbing materials that contain asbestos, call the BellSouth Building Service Center: AL, MS, TN, KY & LA (local area code) 557-6194 FL, GA, NC & SC (local area code) 780-2740

**3. Definitions**

Generator. Under RCRA, the person whose act produces a Hazardous Waste, as defined in 40 C.F.R. § 261, or whose act first causes a Hazardous Waste to become subject to regulation. The Generator is legally responsible for the proper

management and disposal of Hazardous Wastes in accordance with regulations.

Hazardous Chemical. As defined in the U.S. OSHA hazard communications standard (29 C.F.R. § 1910.1200), any chemical which is a health hazard or physical hazard.

Hazardous Waste. As defined in Section 1004 of RCRA.

Imminent Danger. Any conditions or practices at a BellSouth Premises which are such that a danger exists which could reasonably be expected to cause immediate death or serious harm to people or immediate significant damage to the environment or natural resources.

Spill or Release. As defined in Section 101 of CERCLA.

#### 4. **Acronyms**

RCM – Regional Collocation Manager (f/k/a Account Team Collocation Coordinator)

BST – BellSouth Telecommunications

CRES – Corporate Real Estate and Services (formerly PS&M)

DEC/LDEC – Department Environmental Coordinator/Local Department Environmental Coordinator

E/S – Environmental/Safety

EVET – Environmental Vendor Evaluation Team

GU-BTEN-001BT – BellSouth Environmental Methods and Procedures

NESC – National Electrical Safety Codes

P&SM – Property & Services Management

Std T&C – Standard Terms & Conditions

COLLOCATION - Florida											Att: 4 Exh: B										
CATEGORY	RATE ELEMENTS	Interim	Zone	BCS	USOC	RATES(\$)					Svc Order Submitted Elec per LSR	Svc Order Submitted Manually per LSR	Incremental Charge - Manual Svc Order vs. Electronic-1st	Incremental Charge - Manual Svc Order vs. Electronic-Add'l	Incremental Charge - Manual Svc Order vs. Electronic-Disc 1st	Incremental Charge - Manual Svc Order vs. Electronic-Disc Add'l					
						Rec	Nonrecurring		Nonrecurring Disconnect								OSS Rates(\$)				
							First	Add'l	First	Add'l							SOME C	SOMAN	SOMAN	SOMAN	SOMAN
<b>PHYSICAL COLLOCATION</b>																					
<b>Application</b>																					
	Physical Collocation - Initial Application Fee			CLO	PE1BA	2,785.00			1.20												
	Physical Collocation - Subsequent Application Fee			CLO	PE1CA	2,236.00			1.20												
	Physical Collocation - Co-Carrier Cross Connects/Direct Connect, Application Fee, per application			CLO	PE1DT	564.81															
	Physical Collocation - Power Reconfiguration Only, Application Fee			CLO	PE1PR	409.50															
	Physical Collocation Administrative Only - Application Fee			CLO	PE1BL	760.91			1.20												
<b>Space Preparation</b>																					
	Physical Collocation - Floor Space, per sq feet			CLO	PE1PJ	5.28															
	Physical Collocation - Space Enclosure, welded wire, first 50 square feet			CLO	PE1BX	171.12															
	Physical Collocation - Space enclosure, welded wire, first 100 square feet			CLO	PE1BW	189.73															
	Physical Collocation - Space enclosure, welded wire, each additional 50 square feet			CLO	PE1CW	18.61															
	Physical Collocation - Space Preparation - C.O. Modification per square ft.			CLO	PE1SK	2.38															
	Physical Collocation - Space Preparation, Common Systems Modifications-Cageless, per square foot			CLO	PE1SL	2.50															
	Physical Collocation - Space Preparation - Common Systems Modifications-Caged, per cage			CLO	PE1SM	84.93															
	Physical Collocation - Space Preparation - Firm Order Processing			CLO	PE1SJ	287.36															
	Physical Collocation - Space Availability Report, per Central Office Requested			CLO	PE1SR	572.66															
<b>Power</b>																					
	Physical Collocation - Power, -48V DC Power - per Fused Amp Requested			CLO	PE1PL	7.80															
	Physical Collocation - Power, 120V AC Power, Single Phase, per Breaker Amp			CLO	PE1FB	5.26															
	Physical Collocation - Power, 240V AC Power, Single Phase, per Breaker Amp			CLO	PE1FD	10.53															
	Physical Collocation - Power, 120V AC Power, Three Phase, per Breaker Amp			CLO	PE1FE	15.80															
	Physical Collocation - Power, 277V AC Power, Three Phase, per Breaker Amp			CLO	PE1FG	36.47															
	Physical Collocation - Power - DC power, per Used Amp			CLO	PE1FN	10.69															
<b>Cross Connects (Cross Connects, Co-Carrier Cross Connects, and Ports)</b>																					
	Physical Collocation - 2-wire cross-connect, loop, provisioning			UEANL,UEQ,UNCN X, UEA, UCL, UAL, UHL, UDN, UNCXX	PE1P2	0.0208	7.32	5.37	4.58	2.71											
	Physical Collocation - 4-wire cross-connect, loop, provisioning			UEA, UHL, UNCXX, UNCDX, UCL, UDL	PE1P4	0.0416	8.00	5.75	5.00	2.69											
	Physical Collocation -DS1 Cross-Connect for Physical Collocation, provisioning			WDS1L, WDS1S, UXTD1, ULDD1, USLEL, UNLD1, U1TD1, UNC1X, UEPSR, UEPSB, UEPSR, UEPSB, USL, UEPEX, UEPEX, UEPEX, UEPEX	PE1P1	0.3786	7.88	6.25	1.35	0.9899											
	Physical Collocation - DS3 Cross-Connect, provisioning			UE3, U1TD3, UXTD3, UXTS1, UNC3X, UNCSX, ULDD3, U1TS1, ULDS1, UNLD3, UEPEX, UEPEX, UEPEX, UEPEX, UEPSR, UEPSB, UEPEX, UEPEX	PE1P3	4.16	32.40	31.03	11.15	10.98											



COLLOCATION - Florida											Alt: 4 Exh: B										
CATEGORY	RATE ELEMENTS	Interim	Zone	BCS	USOC	RATES(\$)				Svc Order Submitted Elec per LSR	Svc Order Submitted Manually per LSR	Incremental Charge - Manual Svc Order vs. Electronic-1st	Incremental Charge - Manual Svc Order vs. Electronic-Add'l	Incremental Charge - Manual Svc Order vs. Electronic-Disc 1st	Incremental Charge - Manual Svc Order vs. Electronic-Disc Add'l						
						Rec	Nonrecurring		Nonrecurring Disconnect							OSS Rates(\$)					
							First	Add'l	First							Add'l	SOME C	SOMAN	SOMAN	SOMAN	SOMAN
	Physical Collocation - 2-Fiber Cross-Connect			CLO, ULDO3, ULD12, ULD48, U1T03, U1T12, U1T48, UDLO3, UDL12, UDF	PE1F2	1.71	28.26	25.85	13.78	11.01											
	Physical Collocation - 4-Fiber Cross-Connect			ULDO3, ULD12, ULD48, U1T03, U1T12, U1T48, UDLO3, UDL12, UDF, UDFCX	PE1F4	3.34	37.92	35.51	18.20	15.44											
	Physical Collocation - Co-Carrier Cross Connects/Direct Connect - Fiber Cable Support Structure, per linear foot, per cable.			CLO	PE1ES	0.0008															
	Physical Collocation - Co-Carrier Cross Connect/Direct Connect - Copper/Coax Cable Support Structure, per linear foot, per cable.			CLO	PE1DS	0.0012															
	Physical Collocation 2-Wire Cross Connect, Port			UEPSR, UEPSB, UEPSX, UEPS2C	PE1R2	0.0208	7.32	5.37	4.58	2.71											
	Physical Collocation 4-Wire Cross Connect, Port			UEPEX, UEPPD	PE1R4	0.0416	8.00	5.75	5.00	2.69											
<b>Security</b>																					
	Physical Collocation - Security Escort for Basic Time - normally scheduled work, per half hour			CLO	PE1BT		33.65	22.05													
	Physical Collocation - Security Escort for Overtime - outside of normally scheduled working hours on a scheduled work day, per half hour			CLO	PE1OT		44.63	28.89													
	Physical Collocation - Security Escort for Premium Time - outside of scheduled work day, per half hour			CLO	PE1PT		55.62	35.73													
	Physical Collocation - Security Access System - Security System per Central Office, per Sq. Ft.			CLO	PE1AY	0.0101															
	Physical Collocation - Security Access System - New Card Activation, per Card Activation (First), per State			CLO	PE1A1		38.95														
	Physical Collocation - Security Access System - Administrative Change, existing Access Card, per Request, per State, per Card			CLO	PE1AA		8.84														
	Physical Collocation - Security Access System - Replace Lost or Stolen Card, per Card			CLO	PE1AR		28.78														
	Physical Collocation - Security Access - Initial Key, per Key			CLO	PE1AK		23.28														
	Physical Collocation - Security Access - Key, Replace Lost or Stolen Key, per Key			CLO	PE1AL		23.28														
<b>CFA</b>																					
	Physical Collocation - CFA Information Resend Request, per premises, per arrangement, per request			CLO	PE1C9		79.52														
<b>Cable Records - Note: The rates in the First &amp; Additional columns will actually be billed as "Initial I" and "Subsequent S" respectively</b>																					
	Physical Collocation - Cable Records, per request			CLO	PE1CR		1515.00	973.64	256.35												
	Physical Collocation, Cable Records, VG/DS0 Cable, per cable record (maximum 3600 records)			CLO	PE1CD		646.84		362.41												
	Physical Collocation, Cable Records, VG/DS0 Cable, per each 100 pair			CLO	PE1CO		9.11		10.80												
	Physical Collocation, Cable Records, DS1, per T1 TIE			CLO	PE1C1		4.52		5.35												
	Physical Collocation, Cable Records, DS3, per T3 TIE			CLO	PE1C3		15.81		18.73												
	Physical Collocation - Cable Records, Fiber Cable, per cable record (maximum 99 records)			CLO	PE1CB		169.96		149.97												
	Physical Collocation, Cable Records, CA15/RJ45			CLO	PE1C5		4.52		5.35												
<b>Virtual to Physical</b>																					
	Physical Collocation - Virtual to Physical Collocation Relocation, per Voice Grade Circuit			CLO	PE1BV		33.00														
	Physical Collocation - Virtual to Physical Collocation Relocation, per DSO Circuit			CLO	PE1BO		33.00														
	Physical Collocation - Virtual to Physical Collocation Relocation, per DS1 Circuit			CLO	PE1B1		52.00														
	Physical Collocation - Virtual to Physical Collocation Relocation, per DS3 Circuit			CLO	PE1B3		52.00														

COLLOCATION - Florida											Att: 4 Exh: B										
CATEGORY	RATE ELEMENTS	Interim	Zone	BCS	USOC	RATES(\$)				Svc Order Submitted Elec per LSR	Svc Order Submitted Manually per LSR	Incremental Charge - Manual Svc Order vs. Electronic-1st	Incremental Charge - Manual Svc Order vs. Electronic-Add'l	Incremental Charge - Manual Svc Order vs. Electronic-Disc 1st	Incremental Charge - Manual Svc Order vs. Electronic-Disc Add'l						
						Rec	Nonrecurring		Nonrecurring Disconnect							OSS Rates(\$)					
							First	Add'l	First							Add'l	SOMEc	SOMAN	SOMAN	SOMAN	SOMAN
	Physical Collocation - Virtual to Physical Collocation In-Place, Per Voice Grade Circuit			CLO	PE1BR		22.51														
	Physical Collocation Virtual to Physical Collocation In-Place, Per DSO Circuit			CLO	PE1BP		22.51														
	Physical Collocation - Virtual to Physical Collocation In-Place, Per DS1 Circuit			CLO	PE1BS		32.73														
	Physical Collocation - Virtual to Physical Collocation In-Place, per DS3 Circuit			CLO	PE1BE		32.73														
	<b>Entrance Cable</b>																				
	Physical Collocation - Fiber Cable Support Structure, per Entrance Cable			CLO	PE1PM	5.19															
	Physical Collocation - Fiber Entrance Cable per Cable (CO manhole to vault splice)			CLO	PE1EC		994.12		43.84												
	Physical Collocation - Fiber Entrance Cable Installation, per Fiber			CLO	PE1ED		7.43														
	<b>VIRTUAL COLLOCATION</b>																				
	<b>Application</b>																				
	Virtual Collocation - Application Fee			AMTFS	EAf		1,241.00		1.20												
	Virtual Collocation - Co-Carrier Cross Connects/Direct Connect, Application Fee, per application			AMTFS	VE1CA		564.81														
	Virtual Collocation Administrative Only - Application Fee			AMTFS	VE1AF		760.91		1.20												
	<b>Space Preparation</b>																				
	Virtual Collocation - Floor Space, per sq. ft.			AMTFS	ESPvX	5.28															
	<b>Power</b>																				
	Virtual Collocation - Power, per fused amp			AMTFS	ESPAX	6.95															
	Virtual Collocation - Power, DC power, per Used Amp			AMTFS	VE1PF	10.69															
	<b>Cross Connects (Cross Connects, Co-Carrier Cross Connects, and Ports)</b>																				
	Virtual Collocation - 2-wire cross-connect, loop, provisioning			UEANL, UEA, UDN, UAL, UHL, UCL, UEQ, UNCVX, UNCDX, UNCvX	UEAC2	0.0201	7.32	5.37	4.58	2.71											
	Virtual Collocation - 4-wire cross-connect, loop, provisioning			UEA, UHL, UCL, UDL, UNCVX, UNCDX	UEAC4	0.0403	8.00	5.75	5.00	2.69											
	Virtual collocation - Special Access & UNE, cross-connect per DS1			ULR, UXTD1, UNC1X, ULDD1, U1TD1, USLEL, UNLD1, USL, UEPEX, UEPDX	CNC1X	0.3786	7.88	6.26	1.35	0.9915											
	Virtual collocation - Special Access & UNE, cross-connect per DS3			USL, UE3, U1TD3, UXTS1, UXTD3, UNC3X, UNCSX, ULDD3, U1TS1, ULDS1, UDLSX, UNLD3, XDEST	CND3X	4.16	32.40	31.03	11.15	10.98											
	Virtual Collocation - 2-Fiber Cross Connects			UDL12, UDLO3, U1T48, U1T12, U1TO3, ULDO3, ULD12, ULD48, UDF	CNC2F	1.75	28.26	25.85	13.78	11.01											
	Virtual Collocation - 4-Fiber Cross Connects			UDL12, UDLO3, U1T48, U1T12, U1TO3, ULDO3, ULD12, ULD48, UDF	CNC4F	3.50	37.92	35.51	18.20	15.44											
	Virtual Collocation - Co-Carrier Cross Connects/Direct Connect - Fiber Cable Support Structure, per linear foot, per cable			AMTFS	VE1CB	0.0008															
	Virtual Collocation - Co-Carrier Cross Connects/Direct Connect - Copper/Coax Cable Support Structure, per linear foot, per cable			AMTFS	VE1CD	0.0012															
	Virtual Collocation 2-Wire Cross Connect, Port			UEPSX, UEPSB, UEPE, UEPS, UEPSR, UEP2C	VE1R2	0.0201	7.32	5.37	4.58	2.71											

COLLOCATION - Florida										Att: 4 Exh: B											
CATEGORY	RATE ELEMENTS	Interim	Zone	BCS	USOC	RATES(\$)				Svc Order Submitted Elec per LSR	Svc Order Submitted Manually per LSR	Incremental Charge - Manual Svc Order vs. Electronic-1st	Incremental Charge - Manual Svc Order vs. Electronic-Add'l	Incremental Charge - Manual Svc Order vs. Electronic-Disc 1st	Incremental Charge - Manual Svc Order vs. Electronic-Disc Add'l						
						Rec	Nonrecurring		Nonrecurring Disconnect							OSS Rates(\$)					
							First	Add'l	First							Add'l	SOMEc	SOMAN	SOMAN	SOMAN	SOMAN
	Virtual Collocation 4-Wire Cross Connect, Port			UEPDD, UEPEX	VE1R4	0.0403	8.00	5.75	5.00	2.69											
<b>CFA</b>																					
	Virtual Collocation - CFA Information Resend Request, per Premises, per Arrangement, per request			AMTFS	VE1QR		79.52														
<b>Cable Records - Note: The rates in the First &amp; Additional columns will actually be billed as "Initial I" &amp; "Subsequent S" respectively</b>																					
	Virtual Collocation Cable Records - per request			AMTFS	VE1BA	I	1515.00	S	973.64		256.35										
	Virtual Collocation Cable Records - VG/DS0 Cable, per cable record			AMTFS	VE1BB		646.84				362.41										
	Virtual Collocation Cable Records - VG/DS0 Cable, per each 100 pair			AMTFS	VE1BC		9.11				10.80										
	Virtual Collocation Cable Records - DS1, per T1TIE			AMTFS	VE1BD		4.52				5.35										
	Virtual Collocation Cable Records - DS3, per T3TIE			AMTFS	VE1BE		15.81				18.73										
	Virtual Collocation Cable Records - Fiber Cable, per 99 fiber records			AMTFS	VE1BF		169.96				149.97										
	Virtual Collocation Cable Records - CAT 5/RJ45			AMTFS	VE1BS		4.52				5.35										
<b>Security</b>																					
	Virtual collocation - Security escort, basic time, normally scheduled work hours			AMTFS	SPTBX		33.65		22.05												
	Virtual collocation - Security escort, overtime, outside of normally scheduled work hours on a normal working day			AMTFS	SPTOX		44.63		28.89												
	Virtual collocation - Security escort, premium time, outside of a scheduled work day			AMTFS	SPTPX		55.62		35.73												
<b>Maintenance</b>																					
	Virtual collocation - Maintenance in CO - Basic, per half hour			AMTFS	CTRLX		54.05		22.05												
	Virtual collocation - Maintenance in CO - Overtime, per half hour			AMTFS	SPTOM		72.18		28.89												
	Virtual collocation - Maintenance in CO - Premium per half hour			AMTFS	SPTPM		90.31		35.73												
<b>Entrance Cable</b>																					
	Virtual Collocation - Cable Installation Charge, per cable			AMTFS	ESPCX		1,473.00				43.84										
	Virtual Collocation - Cable Support Structure, per cable			AMTFS	ESPSX		4.54														
<b>COLLOCATION IN THE REMOTE SITE</b>																					
<b>Physical Remote Site Collocation</b>																					
	Physical Collocation in the Remote Site - Application Fee			CLORS	PE1RA		612.23				270.35										
	Cabinet Space in the Remote Site per Bay/ Rack			CLORS	PE1RB		154.59														
	Physical Collocation in the Remote Site - Security Access - Key			CLORS	PE1RD		23.28														
	Physical Collocation in the Remote Site - Space Availability Report per Premises Requested			CLORS	PE1SR		223.91														
	Physical Collocation in the Remote Site - Remote Site CLLI Code Request, per CLLI Code Requested			CLORS	PE1RE		73.39														
	Remote Site DLEC Data (BRSDD), per Compact Disk, per CO			CLORS	PE1RR		208.02														
	Physical Collocation - Security Escort for Basic Time - normally scheduled work, per half hour			CLORS	PE1BT		33.65		22.05												
	Physical Collocation - Security Escort for Overtime - outside of normally scheduled working hours on a scheduled work day, per half hour			CLORS	PE1OT		44.63		28.89												
	Physical Collocation - Security Escort for Premium Time - outside of scheduled work day, per half hour			CLORS	PE1PT		55.62		35.73												
<b>Adjacent Remote Site Collocation</b>																					
	Remote Site Adjacent Collocation-Application Fee			CLORS	PE1RU		755.62		755.62												
	Remote Site-Adjacent Collocation - Real Estate, per square foot			CLORS	PE1RT		0.134														
	Remote Site-Adjacent Collocation - AC Power, per breaker amp			CLORS	PE1RS		6.27														
<b>NOTE: If Security Escort and/or Add'l Engineering Fees become necessary for adjacent remote site collocation, the Parties will negotiate appropriate rates.</b>																					
<b>Virtual Remote Site Collocation</b>																					
	Virtual Collocation in the Remote Site - Application Fee			VE1RS	VE1RB		612.23				270.35										
	Virtual Collocation in the Remote Site - Per Bay/Rack of Space			VE1RS	VE1RC		154.59														
	Virtual Collocation in the Remote Site - Space Availability Report per Premises requested			VE1RS	VE1RR		223.91														
	Virtual Collocation in the Remote Site - Remote Site CLLI Code Request, per CLLI Code Requested			VE1RS	VE1RL		73.39														



## **Attachment 5**

### **Access to Numbers and Number Portability**

**TABLE OF CONTENTS**

**1. Non-Discriminatory Access to Telephone Numbers..... 3**

**2. Local Number Portability ..... 4**

**3. Service Order Charges ..... 5**

## **ACCESS TO NUMBERS AND NUMBER PORTABILITY**

### **1. Non-Discriminatory Access to Telephone Numbers**

- 1.1 During the term of this Agreement, where Smart City Communications is utilizing its own switch, Smart City Communications shall contact the North American Numbering Plan Administrator (NANPA), or, where applicable, the relevant Number Pool Administrator for the assignment of numbering resources.
- 1.2 Where BellSouth provides resold services to Smart City Communications, BellSouth will provide Smart City Communications with online access to available telephone numbers as defined by applicable FCC rules and regulations on a first come first served basis. Smart City Communications acknowledges that such access to numbers shall be in accordance with the appropriate FCC rules and regulations. Smart City Communications may designate up to a forecasted six (6) months supply of available numbers as intermediate (an available number provided to Smart City Communications) telephone numbers per rate center if the following conditions are met:
- 1.2.1 Smart City Communications must: (1) indicate that all of the intermediate numbers currently held by Smart City Communications in each rate center where Smart City Communications will be requesting intermediate telephone numbers have six (6) or less months to exhaust; (2) supply projected monthly telephone number demand on a rate center basis for the coming twelve (12) months for each rate center where Smart City Communications will be requesting intermediate telephone numbers; and, (3) demonstrate that the utilization level on current intermediate numbers held by Smart City Communications in the rate center where Smart City Communications is requesting telephone numbers has reached at least seventy-five percent (75%).
- 1.2.2 The above information will be provided by Smart City Communications by submitting to BellSouth a fully completed "CO Code Assignments Months To Exhaust Certification Worksheet – TN Level" (MTE Worksheet), Appendix B to the Central Office Code (NXX) Assignments Guidelines, INC 95-0407-008 for each rate center where Smart City Communications will be requesting intermediate telephone numbers. The utilization level is calculated by dividing all intermediate numbers currently assigned by Smart City Communications to customers by the total number of intermediate numbers held by Smart City Communications in the rate center and multiplying the result by one hundred (100).
- 1.2.3 If fulfilling Smart City Communications's request for intermediate numbers results in BellSouth having to submit a request for additional telephone numbers to a

national numbering administrator (either NANPA CO Code Administration or NeuStar Pooling Administration or their successors), BellSouth will submit the required numbering request to the national numbering administrator to satisfy Smart City Communications's request for intermediate numbers. BellSouth will also pursue all appropriate steps (including submitting a safety valve request (petition) to the appropriate Commission if the numbering request is denied by the national administrator) to satisfy Smart City Communications's request for intermediate numbers. In these cases, BellSouth is not obligated to fulfill the request by Smart City Communications for intermediate numbers unless, and until, BellSouth's request for additional numbering resources is granted.

- 1.2.4 Smart City Communications agrees to supply supporting information for any numbering request and/or safety valve request that BellSouth files pursuant to Section 1.2.3 above.
- 1.3 Smart City Communications acknowledges that there may be instances where there is an industry shortage of available telephone numbers in a number plan area (NPA). These instances occur where a jeopardy status has been declared by NANPA and the industry has determined that limiting the assignment of new numbers is the appropriate method to employ until the jeopardy can be alleviated. In such NPA jeopardy situations where assignment of new numbers is restricted per the jeopardy guidelines developed by the industry, BellSouth may request that Smart City Communications cancel all or a portion of its unassigned intermediate numbers. Smart City Communications's consent to BellSouth's request shall not be unreasonably withheld.

## **2. Local Number Portability**

- 2.1 The Parties will offer LNP in accordance with rules, regulations and guidelines adopted by the Commission, the FCC and industry fora.
- 2.2 Service Management System (SMS) Administration. The Parties will work cooperatively with other local service providers to establish and maintain contracts for the LNP SMS.
- 2.3 Network Architecture. The Parties agree to adhere to applicable FCC rules and orders governing LNP network architecture.
- 2.4 Signaling. In connection with LNP, each Party agrees to use SS7 signaling in accordance with applicable FCC rules and orders.
- 2.5 N-1 Query. The Parties agree to adhere to applicable FCC rules and orders governing LNP N-1 queries.
- 2.6 Porting of Reserved Numbers and Suspended Lines. Customers of each Party may port numbers, via LNP, that are in a denied state or that are on suspend status. In addition, customers of each Party may port reserved numbers that the customer



has paid to reserve. Portable reserved numbers are identified on the Customer Service Record (CSR). In anticipation of porting from one Party to the other Party, a Party's customer may reserve additional telephone numbers and include them with the numbers that are subsequently ported to the other Party. It is not necessary to restore a denied number before it is ported.

- 2.7 Splitting of Number Groups. The Parties shall permit blocks of subscriber numbers (including, but not limited to, Direct Inward Dial (DID) numbers and MultiServ groups) to be split in connection with an LNP request. BellSouth and Smart City Communications shall permit customers who port a portion of DID numbers to retain DID service on the remaining portion of numbers. If a Party requests porting a range of DID numbers smaller than a whole block, that Party shall pay the applicable charges for doing so as set forth in Attachment 2. In the event no rate is set forth in Attachment 2, then the Parties shall negotiate a rate for such services.
- 2.8 The Parties will set Location Routing Number (LRN) unconditional or ten (10) digit triggers where applicable. Where triggers are set, the porting Party will remove the ported number at the same time the trigger is removed.
- 2.9 A trigger order is a service order issued in advance of the porting of a number. A trigger order 1) initiates call queries to the AIN SS7 network in advance of the number being ported; and 2) provides for the new service provider to be in control of when a number ports.
- 2.10 Where triggers are not set, the Parties shall coordinate the porting of the number between service providers so as to minimize service interruptions to the customer.
- 2.11 BellSouth and Smart City Communications will work cooperatively to implement changes to LNP process flows ordered by the FCC or as recommended by standard industry foras addressing LNP.
- 2.12 Where Smart City Communications utilizes BellSouth's LNP Query Service, BellSouth shall bill and Smart City Communications shall pay the query charge associated with LNP Query Service as set forth in Attachment 2. To receive the LNP Query Service charge set forth in Attachment 2, Smart City Communications shall fill out and submit the Interconnection data sheet for BellSouth LNP Query Service. The form can be obtained on BellSouth's Interconnection Web site under BellSouth LNP Query Service and click on forms. Once the form has been filled out and submitted the LNP Query charge will take effect on the approved date. This charge is not subject to the resale discount set forth in Attachment 1.
- 3. Service Order Charges**
- 3.1 The terms, conditions and rates for OSS utilized in connection with LNP are as set forth in Attachment 6 and Exhibit A of Attachment 2.

**Attachment 6**  
**Pre-Ordering, Ordering, Provisioning,**  
**Maintenance and Repair**

**TABLE OF CONTENTS**

**1. Quality of Pre-Ordering, Ordering, Provisioning, Maintenance and Repair ..... 3**

**2. Access to Operations Support Systems..... 3**

**3. Miscellaneous..... 8**

## **PRE-ORDERING, ORDERING, PROVISIONING, MAINTENANCE AND REPAIR**

### **1. Quality of Pre-Ordering, Ordering, Provisioning, Maintenance and Repair**

- 1.1 BellSouth shall provide to Smart City Communications nondiscriminatory access to its OSS and the necessary information contained therein in order that Smart City Communications can perform the functions of pre-ordering, ordering, provisioning, maintenance and repair, and billing. BellSouth shall provide Smart City Communications with all relevant documentation (manuals, user guides, specifications, etc.) regarding business rules and other formatting information as well as practices and procedures necessary to ensure requests are efficiently processed. All documentation will be readily accessible at BellSouth's Interconnection Web site. BellSouth shall ensure that its OSS are designed to accommodate requests for both current and projected demands of Smart City Communications and other CLECs in the aggregate.

### **2. Access to Operations Support Systems**

- 2.1 BellSouth shall provide to Smart City Communications nondiscriminatory access to its OSS and the necessary information contained therein in order that Smart City Communications can perform the functions of pre-ordering, ordering, provisioning, maintenance and repair, and billing. BellSouth shall provide nondiscriminatory access to the OSS through manual and/or electronic interfaces as described in this Attachment. It is the sole responsibility of Smart City Communications to obtain the technical capability to access and utilize BellSouth's OSS interfaces. Specifications for Smart City Communications's access and use of BellSouth's electronic interfaces are set forth at BellSouth's Interconnection Web site.

- 2.1.1 Smart City Communications agrees to comply with the provisions of the OSS Interconnection Volume Guidelines as set forth at BellSouth's Interconnection Web site.

#### **2.2 Pre-Ordering**

- 2.2.1 BellSouth will provide electronic access to its OSS and the information contained therein in order that Smart City Communications can perform the following pre-ordering functions: service address validation, telephone number selection, service and feature availability, due date information, customer record information and loop makeup information. Mechanized access is provided by electronic interfaces whose specifications for access and use are set forth at BellSouth's Interconnection Web site. The process by which the Parties will manage these electronic interfaces to include the development and introduction of new interfaces

will be governed by the change management process as described in Section 2.7 below.

- 2.2.2 BellSouth shall provide to Smart City Communications electronic access to customer service record information in accordance with the applicable performance intervals referenced in Attachment 9. If electronic access is not available, BellSouth shall provide to Smart City Communications such information within twenty-four (24) hours. Smart City Communications shall provide to BellSouth access to customer record information, including circuit numbers associated with each telephone number where applicable. Smart City Communications shall provide such information within four (4) hours after request via electronic access where available. If electronic access is not available, Smart City Communications shall provide to BellSouth paper copies of customer record information, including circuit numbers associated with each telephone number where applicable. Smart City Communications shall provide to BellSouth such customer service records within twenty-four (24) hours of a valid request, exclusive of Saturdays, Sundays and holidays.
- 2.2.3 The Parties agree not to view, copy, or otherwise obtain access to the other Party's customer record information about any of the other Party's customers without that customer's permission. Smart City Communications will obtain access to customer record information only in strict compliance with applicable laws, rules, or regulations of the state in which the service is provided. BellSouth reserves the right to audit Smart City Communications's access to customer record information. If BellSouth has reason to believe, through its audit or by any other means, that Smart City Communications is accessing customer record information without having obtained the proper customer authorization, BellSouth upon reasonable notice to Smart City Communications may take corrective action, including but not limited to suspending or terminating Smart City Communications's access to BellSouth's pre-ordering and ordering OSS, and the provisioning of pending and existing services.
- 2.3 Ordering
- 2.3.1 BellSouth will make available to Smart City Communications electronic interfaces for the purpose of exchanging order information, including order status and completion notification, for non-complex and certain complex resale requests and certain network elements. Specifications for access and use of BellSouth's electronic interfaces are set forth at BellSouth's Interconnection Web site. The process by which the Parties will manage these electronic interfaces to include the development and introduction of new interfaces will be governed by the change management process as described in Section 2.7 below.
- 2.3.2 Smart City Communications shall place orders for services by submitting a LSR to BellSouth. BellSouth shall bill Smart City Communications an electronic service

order charge at the rate set forth in the applicable Attachment to this Agreement for each LSR submitted by means of an electronic interface. BellSouth shall bill Smart City Communications a manual service order charge at the rate set forth in the applicable Attachment to this Agreement for each LSR submitted by means other than the electronic Interfaces (e.g., mail, fax, courier, etc.). An individual LSR will be identified for billing purposes by its PON.

- 2.3.2.1 Smart City Communications may submit an LSR to request that a customer's service be temporarily suspended, denied, or restored. Alternatively, Smart City Communications may submit a list of such customers if Smart City Communications provides a separate PON for each location on the list. BellSouth will bill an electronic or manual service order charge for each location.
- 2.3.2.2 BellSouth will bill the electronic or manual service order charge, as applicable, for an LSR, regardless of whether that LSR is later supplemented, clarified or cancelled.
- 2.3.2.3 Notwithstanding the foregoing, BellSouth will not bill an additional electronic or manual service order charge for supplements to any LSR submitted to clarify, correct, change or cancel a previously submitted LSR.
- 2.3.2.4 BellSouth shall return a Firm Order Confirmation (FOC) or LSR clarification in accordance with the applicable performance intervals referenced in Attachment 9. Smart City Communications shall provide to BellSouth a FOC within twenty-four (24) hours of the receipt from BellSouth of a complete and accurate LSR, exclusive of Saturdays, Sundays and holidays. Smart City Communications shall provide to BellSouth an LSR clarification within twenty-four (24) hours of the receipt from BellSouth of an incomplete and inaccurate LSR, exclusive of Saturdays, Sundays and holidays.

## 2.4 Provisioning

- 2.4.1 BellSouth shall provision services during its regular working hours. To the extent Smart City Communications requests provisioning of service to be performed outside BellSouth's regular working hours, or the work so requested requires BellSouth's technicians or project managers to work outside of regular working hours, overtime charges set forth in BellSouth's intrastate Access Services Tariff, Section E13.2, shall apply. Notwithstanding the foregoing, if such work is performed outside of regular working hours by a BellSouth technician or project manager during his or her scheduled shift and BellSouth does not incur any overtime charges in performing the work on behalf of Smart City Communications, BellSouth will not assess Smart City Communications additional charges beyond the rates and charges specified in this Agreement.
- 2.4.2 In the event BellSouth must dispatch to the customer's location more than once due to incorrect or incomplete information provided by Smart City

Communications (e.g., incomplete address, incorrect contact name/number, etc.), BellSouth will bill Smart City Communications for each additional dispatch required to provision the circuit due to the incorrect/incomplete information provided. BellSouth will assess the applicable Maintenance of Service rates from BellSouth's FCC No. 1 Tariff, Section 13.3.1.

- 2.4.3 Cancellation Charges. If Smart City Communications cancels an LSR for network elements or resold services subsequent to BellSouth's generation of a service order, any costs incurred by BellSouth in conjunction with provisioning of Services as requested on the cancelled LSR will be recovered in accordance with the cancellation methodology set forth in the Cancellation Charge Percentage Chart found on BellSouth's Interconnection Web site. In addition, BellSouth reserves the right to assess cancellation charges if Smart City Communications fails to respond within nine (9) business days to a Missed Appointment order notification.
- 2.4.3.1 Notwithstanding the foregoing, if Smart City Communications places an LSR based upon BellSouth's loop makeup information, and such information is inaccurate resulting in the inability of BellSouth to provision the network elements requested and another spare compatible facility cannot be found with the transmission characteristics of the network elements originally requested, cancellation charges described in this Section shall not apply. Where Smart City Communications places a single LSR for multiple network elements or services based upon loop makeup information, and information as to some, but not all, of the network elements or services is inaccurate, if BellSouth cannot provision the network elements or services that were the subject of the inaccurate loop makeup information, Smart City Communications may cancel its request for those network elements or services without incurring cancellation charges as described in this Section. In such instance, should Smart City Communications elect to cancel the entire LSR, cancellation charges as described in this Section shall apply to those elements and services that were not the subject of inaccurate loop makeup.
- 2.4.4 Service Date Advancement Charges (Expedites). For Service Date Advancement requests by Smart City Communications, Service Date Advancement charges will apply for intervals less than the standard interval as outlined in the BellSouth Product and Services Interval Guide. The charges are as set forth in Exhibit A of Attachment 2.
- 2.4.5 Order Modification Charges. If Smart City Communications modifies an order after being sent a FOC from BellSouth, the Order Modification Charge (OMC) or Order Modification Charge Additional Dispatch (OMCAD) will be paid by Smart City Communications in accordance with Exhibit A of Attachment 2.

## 2.5 Maintenance and Repair

- 2.5.1 BellSouth will make available to Smart City Communications electronic interfaces for the purpose of reporting and monitoring service troubles. Specifications for access and use of BellSouth's maintenance and repair electronic interfaces are set forth at BellSouth's Interconnection Web site. The process by which the Parties will manage these electronic interfaces to include the development and introduction of new interfaces will be governed by the change management process as described in Section 2.7 below. Requests for trouble repair are billed in accordance with the provisions of this Agreement. BellSouth and Smart City Communications agree to adhere to BellSouth's Operational Understanding. The Operational Understanding may be accessed via BellSouth's Interconnection Web site.
- 2.5.2 If Smart City Communications reports a trouble on a BellSouth Network Element and no trouble is found in BellSouth's network, BellSouth will charge Smart City Communications a Maintenance of Service Charge for any dispatching and testing (both inside and outside the CO) required by BellSouth in order to confirm the working status. BellSouth will assess the Maintenance of Service rates as set forth in BellSouth's FCC No. 1 Tariff, Section 13.3.1.
- 2.5.2.1 In the event BellSouth must dispatch to the customer's location more than once due to incorrect or incomplete information provided by Smart City Communications (e.g., incomplete address, incorrect contact name/number, etc.), BellSouth will bill Smart City Communications for each additional dispatch required to repair the circuit due to the incorrect/incomplete information provided. BellSouth will assess the Maintenance of Service rates as set forth in BellSouth's FCC No. 1 Tariff, Section 13.3.1.
- 2.5.3 If Smart City Communications reports a trouble on a or a resold service and no trouble is found in BellSouth's network, BellSouth will charge Smart City Communications a Trouble Determination Charge or a Trouble Location Charge for any dispatching and testing (both inside and outside the CO) required by BellSouth in order to confirm the working status. BellSouth will assess the Trouble Determination Charge or Trouble Location Charge from the applicable BellSouth tariff.
- 2.5.3.1 In the event BellSouth must dispatch to the customer's location more than once due to incorrect or incomplete information provided by Smart City Communications (e.g., incomplete address, incorrect contact name/number, etc.), BellSouth will bill Smart City Communications for each additional dispatch required to repair the circuit due to the incorrect/incomplete information provided. BellSouth will assess the Trouble Determination Charge or Trouble Location Charge from the applicable BellSouth tariff.



- 2.6 Billing. BellSouth will provide Smart City Communications nondiscriminatory access to billing information as specified in Attachment 7.
- 2.7 Change Management. The Parties agree that the collaborative change management process known as the Change Control Process (CCP) will be used to manage changes to existing interfaces, introduction of new interfaces and retirement of interfaces. The Parties agree to comply with the provisions of the documented CCP as may be amended from time to time and incorporated herein by reference. The change management process will cover changes to BellSouth's electronic interfaces, BellSouth's testing environment, associated manual process improvements, and relevant documentation. The process will define a procedure for resolution of change management disputes. Documentation of the CCP as well as related information and processes will be clearly organized and readily accessible to Smart City Communications at BellSouth's Interconnection Web site.
- 2.8 Rates. Unless otherwise specified herein, charges for the use of BellSouth's OSS, and other charges applicable to pre-ordering, ordering, provisioning and maintenance and repair, shall be at the rates set forth in the applicable Attachment of this Agreement.
- 2.9 The Commissions in some states have ordered per element manual additive nonrecurring charges for Network Elements and Other Services ordered by means other than one of the interactive interfaces. These ordered Network Elements and Other Services manual additive nonrecurring charges will apply in these states, rather than the charge per LSR. The per element charges are listed in Exhibit A of Attachment 2.
- 3. Miscellaneous**
- 3.1 Pending Orders. To the extent that Smart City Communications submits an LSR with incomplete, incorrect or conflicting information, BellSouth will return the LSR to Smart City Communications for clarification. Smart City Communications shall respond to the request for clarification within thirty (30) days by submitting a supplemental LSR. If Smart City Communications does not submit a supplement LSR within thirty (30) days, BellSouth will cancel the original LSR and Smart City Communications shall be required to submit a new LSR, with a new PON.
- 3.2 Single Point of Contact. Smart City Communications will be the single point of contact with BellSouth for ordering activity for network elements and other services used by Smart City Communications to provide services to its customers, except that BellSouth may accept a request directly from another CLEC, or BellSouth, acting with authorization of the affected customer. Smart City Communications and BellSouth shall each execute a blanket LOA with respect to customer requests so that prior proof of customer authorization will not be necessary with every request (except in the case of a local service freeze). The

Parties shall each be entitled to adopt their own internal processes for verification of customer authorization for requests, provided, however, that such processes shall comply with applicable state and federal law and industry and regulatory guidelines. Pursuant to a request from another carrier, BellSouth may disconnect any network element being used by Smart City Communications to provide service to that customer and may reuse such network elements or facilities to enable such other carrier to provide service to the customer. BellSouth will notify Smart City Communications that such a request has been processed but will not be required to notify Smart City Communications in advance of such processing.

- 3.2.1 Neither Party shall prevent or delay a customer from migrating to another carrier because of unpaid bills, denied service, or contract terms.
- 3.2.2 Use of Facilities. When a customer of Smart City Communications elects to discontinue service and to transfer service to another local exchange carrier, including BellSouth, BellSouth shall have the right to reuse the facilities provided to Smart City Communications, regardless whether those facilities are provided as Network Elements or as part of a resold service, and regardless of whether the end user served with such facilities has paid all charges to Smart City Communications or has been denied service for nonpayment or otherwise. BellSouth will notify Smart City Communications that such a request has been processed after the disconnect order has been completed.
- 3.3 Contact Numbers. The Parties agree to provide one another with toll-free nation-wide (50 states) contact numbers for the purpose of ordering, provisioning and maintenance of services. Contact numbers for maintenance/repair of services shall be staffed twenty-four (24) hours per day, seven (7) days per week. BellSouth will close trouble tickets after making a reasonable effort to contact Smart City Communications for authorization to close a ticket. BellSouth will place trouble tickets in delayed maintenance status after making a reasonable effort to contact Smart City Communications to request additional information or to request authorization for additional work deemed necessary by BellSouth.
- 3.4 Subscription Functions. In cases where BellSouth performs subscription functions for an IXC (i.e., PIC and LPIC changes via Customer Account Record Exchange (CARE)), BellSouth will in all possible instances provide the affected IXCs with the OCN of the local provider for the purpose of obtaining customer billing account and other customer information required under subscription requirements.
- 3.4.1 When Smart City Communications's customer, served by resale or loop and port combinations, changes its PIC or LPIC, and per BellSouth's FCC or state tariff the interexchange carrier elects to charge the customer the PIC or LPIC change charge, BellSouth will bill the PIC or LPIC change charge to Smart City Communications, which has the billing relationship with that customer, and Smart City Communications may pass such charge to the customer.



**Attachment 7**

**Billing**

**TABLE OF CONTENTS**

**1. Payment and Billing Arrangements ..... 3**

**2. Billing Disputes ..... 10**

**3. Non-Intercompany Settlements..... 10**

## BILLING

### 1. Payment and Billing Arrangements

The terms and conditions set forth in this Attachment shall apply to all services ordered and provisioned pursuant to this Agreement.

- 1.1 BellSouth will bill through the Carrier Access Billing System (CABS), Integrated Billing System (IBS) and/or the Customer Records Information Systems (CRIS) depending on the particular service(s) provided to Smart City Communications under this Agreement. BellSouth will use its best efforts to format bills in CABS Billing Output Specification (CBOS) standard format. BellSouth's billing format may change in accordance with applicable industry standards; provided, however, that BellSouth may, in some instances, not apply CBOS standard format for certain types of billing for certain products and services. Billing in a format other than CBOS shall not be the basis of any Smart City Communications dispute or withholding of payment.
  - 1.1.1 For any service(s) BellSouth receives from Smart City Communications, Smart City Communications shall bill BellSouth in CBOS format.
  - 1.1.2 Any switched access charges associated with interexchange carrier access to the resold local exchange lines will be billed by, and due to BellSouth.
  - 1.1.3 BellSouth will render bills each month on established bill days for each of Smart City Communications's accounts. If either Party requests multiple billing media or additional copies of the bills, the billing Party will provide these at the rates set forth in BellSouth's FCC No. 1 Tariff, Section 13.3.6.3, except for resold services which shall be at the rates set forth in BellSouth's Non-Regulated Services Pricing List N6.
  - 1.1.4 BellSouth will bill Smart City Communications in advance for all services to be provided during the ensuing billing period except charges associated with service usage and nonrecurring charges, which will be billed in arrears.
    - 1.1.4.1 For resold services, charges for services will be calculated on an individual customer account level, including, if applicable, any charge for usage or usage allowances. BellSouth will also bill Smart City Communications, and Smart City Communications will be responsible for and remit to BellSouth, all charges applicable to said services including but not limited to 911 and E911 charges, EUCL charges, federal subscriber line charges, telecommunications relay charges, and franchise fees, unless otherwise ordered by a Commission.
  - 1.1.5 BellSouth will not perform billing and collection services for Smart City Communications as a result of the execution of this Agreement.
- 1.2 Establishing Accounts and Subsequent State Certifications. After submitting a credit profile and deposit, if required, and after receiving certification as a local

exchange carrier from the appropriate Commission, Smart City Communications will provide the appropriate BellSouth Local Contract Manager responsible for new CLEC activation, the necessary documentation to enable BellSouth to establish accounts for Local Interconnection, Network Elements and Other Services and/or resold services. Such documentation shall include the Application for Master Account, if applicable, proof of authority to provide Telecommunications Services, the appropriate OCN for each state as assigned by the NECA, CIC, if applicable, ACNA, if applicable, BellSouth's blanket form LOA, Misdirected Number form, and a tax exemption certificate, if applicable. Notwithstanding anything to the contrary in this Agreement, Smart City Communications may not order services under a new account and/or subsequent state certification, established in accordance with this Section until thirty (30) days after all information specified in this Section is received from Smart City Communications.

- 1.2.1 ACNAs. Smart City Communications shall provide BellSouth with documentation from Telcordia identifying the ACNA assigned to it by Telcordia (as applicable) in the same legal name as reflected in the preamble to this Agreement. Such ACNA will be used by Smart City Communications to order services pursuant to this Agreement and will not be shared by Smart City Communications with another entity.
- 1.2.2 Company Identifiers. If Smart City Communications needs to change, add to, eliminate or convert its OCN(s), ACNAs and other identifying codes (collectively "Company Identifiers") under which it operates when Smart City Communications has already been conducting business utilizing those Company Identifiers, Smart City Communications shall follow the Mergers and Acquisitions Process as described on BellSouth's Interconnection Web site, and shall be subject to separately negotiated rates, terms and conditions.
- 1.2.3 Tax Exemption. It is the responsibility of Smart City Communications to provide BellSouth with a properly completed tax exemption certificate in the current version of the form customarily used by BellSouth and at intervals required by the appropriate taxing authorities or reasonably requested by BellSouth. A tax exemption certificate must be supplied for each individual Smart City Communications entity purchasing Services under this Agreement. Upon BellSouth's receipt of a properly completed tax exemption certificate, subsequent billings to Smart City Communications will not include those taxes or fees from which Smart City Communications is exempt. Prior to receipt of a properly completed exemption certificate, BellSouth shall bill, and Smart City Communications shall pay all applicable taxes and fees. In the event that Smart City Communications believes that it is entitled to an exemption from and refund of taxes with respect to the amount billed prior to BellSouth's receipt of a properly completed exemption certificate, BellSouth shall assign to Smart City Communications its rights to claim a refund of such taxes. If applicable law prohibits the assignment of tax refund rights or requires the claim for refund of

such taxes to be filed by BellSouth, BellSouth shall, after receiving a written request from Smart City Communications and at Smart City Communications's sole expense, pursue such refund claim on behalf of Smart City Communications, provided that Smart City Communications promptly reimburses BellSouth for any costs and expenses incurred by BellSouth in pursuing such refund claim; and, provided further, that BellSouth shall have the right to deduct any such outstanding costs and expenses from the amount of any refund obtained prior to remitting such refund to Smart City Communications or to deduct any such outstanding costs and expenses from any amounts owed by BellSouth to Smart City Communications if no refund is obtained. Smart City Communications shall be solely responsible for the computation, tracking, reporting and payment of all taxes and fees associated with the services provided by Smart City Communications to its customers.

- 1.3 Deposit Policy. Prior to the inauguration of service or, thereafter, upon BellSouth's request, Smart City Communications shall complete the BellSouth Credit Profile (BellSouth form) and provide information to BellSouth regarding Smart City Communications's credit and financial condition. Based on BellSouth's analysis of the BellSouth Credit Profile and other relevant information regarding Smart City Communications's credit and financial condition, BellSouth reserves the right to require Smart City Communications to provide BellSouth with a suitable form of security deposit for Smart City Communications's account(s). If, in BellSouth's sole discretion, circumstances so warrant and/or Smart City Communications's gross monthly billing has increased, BellSouth reserves the right to request additional security (or to require a security deposit if none was previously requested) and/or file a Uniform Commercial Code (UCC-1) security interest in Smart City Communications's "accounts receivables and proceeds".
- 1.3.1 Security deposit shall take the form of cash, an irrevocable letter of credit (BellSouth form), surety bond (BellSouth form) or, in BellSouth's sole discretion, some other form of security proposed by Smart City Communications and accepted by BellSouth. Any such security deposit shall in no way release Smart City Communications from its obligation to make complete and timely payments of its bill(s). If BellSouth requires Smart City Communications to provide a security deposit, Smart City Communications shall provide such security deposit prior to the inauguration of service or within fifteen (15) days of BellSouth's request, as applicable. Security deposit request notices will be sent to Smart City Communications via certified mail or overnight delivery. Such notice period will start the day after the deposit request notice is rendered by certified mail or overnight delivery. Interest on a cash security deposit shall accrue and be applied or refunded in accordance with the terms in BellSouth's GSST.
- 1.3.2 Security deposits collected under this Section shall not exceed two (2) months' estimated billing for services pursuant to this Agreement. Estimated billings are calculated based upon the monthly average of the previous six (6) months current



billings, if Smart City Communications has received service from BellSouth during such period at a level comparable to that anticipated to occur over the next six (6) months. If either Smart City Communications or BellSouth has reason to believe that the level of service to be received during the next six (6) months will be materially higher or lower than received in the previous six (6) months, Smart City Communications and BellSouth shall agree on a level of estimated billings based on all relevant information.

1.3.3 In the event Smart City Communications fails to provide BellSouth with a suitable form of security deposit or additional security deposit as required herein, defaults on its account(s), or otherwise fails to make any payment or payments required under this Agreement in the manner and within the time required, service to Smart City Communications may be Suspended, Discontinued or Terminated in accordance with the terms of Section 1.5 below. Upon Termination of services, BellSouth shall apply any security deposit to Smart City Communications's final bill for its account(s). If no bill is rendered to Smart City Communications, BellSouth shall, nevertheless, apply any security deposit to Smart City Communications's outstanding balance.

1.3.3.1 At least seven (7) days prior to the expiration of any letter of credit provided by Smart City Communications as security under this Agreement, Smart City Communications shall renew such letter of credit or provide BellSouth with evidence that Smart City Communications has obtained a suitable replacement for the letter of credit. If Smart City Communications fails to comply with the foregoing, BellSouth shall thereafter be authorized, in its sole discretion, to draw down the full amount of such letter of credit and utilize the cash proceeds as security for Smart City Communications accounts(s). If Smart City Communications provides a security deposit or additional security deposit in the form of a surety bond as required herein, Smart City Communications shall renew the surety bond or provide BellSouth with evidence that Smart City Communications has obtained a suitable replacement for the surety bond at least seven (7) days prior to the cancellation date of the surety bond. If Smart City Communications fails to comply with the foregoing, BellSouth shall thereafter be authorized, in its sole discretion, to take action on the surety bond and utilize the cash proceeds as security for Smart City Communications's account(s). If the credit rating of any bonding company that has provided Smart City Communications with a surety bond provided as security hereunder has fallen below B, BellSouth will provide written notice to Smart City Communications that Smart City Communications must provide a replacement bond or other suitable security within fifteen (15) days of BellSouth's written notice. If Smart City Communications fails to comply with the foregoing, BellSouth shall thereafter be authorized, in its sole discretion, to take action on the surety bond and utilize the cash proceeds as security for Smart City Communications's account(s). Notwithstanding anything contained in this Agreement to the contrary, BellSouth shall be authorized, in its sole discretion, to draw down the full amount of any letter of credit or take action on any surety bond provided by Smart City

Communications as security hereunder if Smart City Communications defaults on its account(s) or otherwise fails to make any payment or payments required under this Agreement in the manner and within the time, as required herein and apply the cash proceeds to any outstanding balance on Smart City Communications's accounts and utilize any remaining cash proceeds as security for Smart City Communications's account(s).

- 1.4 Payment Responsibility. Payment of all charges will be the responsibility of Smart City Communications. Smart City Communications shall pay invoices by utilizing wire transfer services or automatic clearing house services. Smart City Communications shall make payment to BellSouth for all services billed including disputed amounts. BellSouth will not become involved in billing disputes that may arise between Smart City Communications and Smart City Communications's customer.
- 1.4.1 Payment Due. Payment for services provided by BellSouth, including disputed charges, is due on or before the next bill date. Information required to apply payments must accompany the payment. The information must notify BellSouth of Billing Account Numbers (BAN) paid; invoices paid and the amount to be applied to each BAN and invoice (Remittance Information). Payment is considered to have been made when the payment and Remittance Information are received by BellSouth. If the Remittance Information is not received with payment, BellSouth will be unable to apply amounts paid to Smart City Communications's accounts. In such event, BellSouth shall hold such funds until the Remittance Information is received. If BellSouth does not receive the Remittance Information by the payment due date for any account(s), late payment charges shall apply.
- 1.4.1.1 Due Dates. If the payment due date falls on a Sunday or on a holiday that is observed on a Monday, the payment due date shall be the first non-holiday day following such Sunday or holiday. If the payment due date falls on a Saturday or on a holiday which is observed on Tuesday, Wednesday, Thursday, or Friday, the payment due date shall be the last non-holiday day preceding such Saturday or holiday. If payment is not received by the payment due date, a late payment charge, as set forth in Section 1.4.1.2, below, shall apply.
- 1.4.1.2 Late Payment. If any portion of the payment is not received by BellSouth on or before the payment due date as set forth above, or if any portion of the payment is received by BellSouth in funds that are not immediately available to BellSouth, then a late payment and/or interest charge shall be due to BellSouth. The late payment and/or interest charge shall apply to the portion of the payment not received and shall be assessed as set forth in Section A2 of BellSouth's GSST, Section B2 of the Private Line Service Tariff or Section E2 of the BellSouth intrastate Access Services Tariff, or pursuant to the applicable state law as determined by BellSouth. In addition to any applicable late payment and/or interest charges, Smart City Communications may be charged a fee for all returned checks

at the rate set forth in Section A2 of BellSouth's GSST or pursuant to the applicable state law.

- 1.5 Discontinuing Service to Smart City Communications. The procedures for discontinuing service to Smart City Communications are as follows:
- 1.5.1 In order of severity, Suspend/Suspension, Discontinue/Discontinuance and Terminate/Termination are defined as follows for the purposes of this Attachment:
- 1.5.1.1 Suspend/Suspension is the temporary restriction of the billed Party's access to the ordering systems and/or access to the billed Party's ability to initiate PIC-related changes. In addition, during Suspension, pending orders may not be completed and orders for new service or changes to existing services may not be accepted.
- 1.5.1.2 Discontinue/Discontinuance is the denial of service by the billing Party to the billed Party that will result in the disruption and discontinuation of service to the billed Party's customers. Additionally, at the time of Discontinuance, BellSouth will remove any Local Service Freezes in place on the billed Party's customers.
- 1.5.1.3 Terminate/Termination is the disconnection of service by the billing Party to the billed Party.
- 1.5.2 BellSouth reserves the right to Suspend, Discontinue or Terminate service in the event of prohibited, unlawful or improper use of BellSouth facilities or service, abuse of BellSouth facilities, or any other violation or noncompliance by Smart City Communications of the rules and regulations of BellSouth's tariffs.
- 1.5.3 Suspension. If payment of amounts due as described herein is not received by the bill date in the month after the original bill date, or fifteen (15) days from the date of a deposit request in the case of security deposits, BellSouth will provide written notice to Smart City Communications that services will be Suspended if payment of such amounts, and all other amounts that become past due before Suspension, is not received by wire transfer, automatic clearing house or cashier's check in the manner set forth in Section 1.4.1 above, or in the case of a security deposit request, in the manner set forth in Section 1.3.1 above: (1) within seven (7) days following such notice for CABS billed services; (2) within fifteen (15) days following such notice for CRIS and IBS billed services; and (3) within seven (7) days following such notice for security deposit requests.
- 1.5.3.1 The Suspension notice shall also provide that all past due charges for CRIS and IBS billed services, and all other amounts that become past due for such services before Discontinuance, must be paid within thirty (30) days from the date of the Suspension notice to avoid Discontinuance of CRIS and IBS billed services.
- 1.5.3.2 For CABS billed services, BellSouth will provide a Discontinuance notice that is separate from the Suspension notice, that all past due charges for CABS billed Services, and all other amounts that become past due for such services before

Discontinuance, must be paid within thirty (30) days from the date of the Suspension notice to avoid Discontinuance of CABS billed services. This Discontinuance notice may be provided at the same time that BellSouth provides the Suspension notice.

1.5.4 Discontinuance. If payment of amounts due as described herein is not received by the bill date in the month after the original bill date, BellSouth will provide written notice that BellSouth may Discontinue the provision of existing services to Smart City Communications if payment of such amounts, and all other amounts that become past due before Discontinuance, including requested security deposits, is not received by wire transfer, automatic clearing house or cashier's check in the manner set forth in Section 1.4.1 above or in the case of a deposit in accordance with Section 1.3.1 above, within thirty (30) days following such written notice; provided, however, that BellSouth may provide written notice that such existing services may be Discontinued within fifteen (15) days following such notice, subject to the criteria described in Section 1.5.4.1 below.

1.5.4.1 BellSouth may take the action to Discontinue the provision of existing service upon fifteen (15) days from the day after BellSouth provides written notice of such Discontinuance if (a) such notice is sent by certified mail or overnight delivery; (b) Smart City Communications has not paid all amounts due pursuant to a subject bill(s), or has not provided adequate security pursuant to a deposit request; and (c) either:

(1) BellSouth has sent the subject bill(s) to Smart City Communications within seven (7) business days of the bill date(s), verifiable by records maintained by BellSouth:

- i. in paper or CDROM form via the United States Postal Service (USPS), or
- ii. in magnetic tape form via overnight delivery, or
- iii. via electronic transmission; or

(2) BellSouth has sent the subject bill(s) to Smart City Communications, using one of the media described in (1) above, more than thirty (30) days before notice to Discontinue service has been rendered.

1.5.4.2 In the case of Discontinuance of services, all billed charges, as well as applicable disconnect charges, shall become due.

1.5.4.3 Smart City Communications is solely responsible for notifying the customer of the Discontinuance of service. If, within seven (7) days after Smart City Communications's services have been Discontinued, Smart City Communications pays, by wire transfer, automatic clearing house or cashier's check, all past due charges, including late payment charges, outstanding security deposit request amounts if applicable and any applicable restoral charges as set forth in Section A4

of BellSouth's GSST, then BellSouth will reestablish service for Smart City Communications.

- 1.5.5 Termination. If within seven (7) days after Smart City Communications's service has been Discontinued and Smart City Communications has failed to pay all past due charges as described above, then Smart City Communications's service will be Terminated.

## **2. Billing Disputes**

- 2.1 Smart City Communications shall electronically submit all billing disputes to BellSouth using the form specified by BellSouth. In the event of a billing dispute, the Parties will endeavor to resolve the dispute within sixty (60) days of the notification date. Within five (5) business days of BellSouth's denial, or partial denial, of the billing dispute, if Smart City Communications is not satisfied with BellSouth's resolution of the billing dispute or if no response to the billing dispute has been received by Smart City Communications by such sixtieth (60<sup>th</sup>) day, Smart City Communications must pursue the escalation process as outlined in the Billing Dispute Escalation Matrix, set forth on BellSouth's Interconnection Services Web site, or the billing dispute shall be considered denied and closed. If, after escalation, the Parties are unable to reach resolution, then the aggrieved Party, if it elects to pursue the dispute shall pursue dispute resolution in accordance with General Terms and Conditions.

- 2.2 For purposes of this Section 2, a billing dispute means a reported dispute submitted pursuant to Section 2.1 above of a specific amount of money actually billed by BellSouth within twelve (12) months of the submission of such dispute. Smart City Communications agrees to not submit billing disputes for amounts billed more than twelve (12) months prior to submission of a billing dispute filed for amounts billed. The billing dispute must be clearly explained by Smart City Communications and supported by written documentation, which clearly shows the basis for disputing charges. The determination as to whether the billing dispute is clearly explained or clearly shows the basis for disputing charges shall be within BellSouth's sole reasonable discretion. Disputes that are not clearly explained or those that do not provide complete information may be rejected by BellSouth. Claims by Smart City Communications for damages of any kind will not be considered a billing dispute for purposes of this Section. If BellSouth resolves the billing dispute, in whole or in part, in favor of Smart City Communications, any credits and interest due to Smart City Communications as a result thereof shall be applied to Smart City Communications's account by BellSouth upon resolution of the billing dispute.

## **3. Non-InterCompany Settlements**

- 3.1 Direct Participants are Telecommunications carriers that exchange data directly with other Direct Participants via the Centralized Message Distribution System (CMDS) Data Center (Direct Participant) and may act as host companies (Host)

for those Telecommunications carriers that do not exchange data directly via the CMDS Data Center.

- 3.2 The Non-InterCompany Settlements (NICS) is the national system administered by Telcordia that is used in the settlement of revenues for calls that are originated and billed by two (2) different local exchange carriers (LEC) within a single Direct Participant's territory to another for billing. NICS applies to calls involving another LEC where the Earning Company and the Billing Company are located within BellSouth's territory.
- 3.3 In association with message distribution service, BellSouth will provide Smart City Communications with associated intercompany settlements reports as appropriate.
- 3.4 Notwithstanding anything in this Agreement to the contrary, in no case shall either Party be liable to the other for any direct or consequential damages incurred as a result of the obligations set out in this Section 3.
- 3.5 Intercompany Settlements Messages
- 3.5.1 Intercompany Settlements Messages facilitate the settlement of revenues associated with traffic originated from or billed by Smart City Communications as a facilities based provider of local exchange Telecommunications Services.
- 3.5.2 BellSouth will receive the monthly NICS reports from Telcordia on behalf of Smart City Communications and will distribute copies of these reports to Smart City Communications on a monthly basis.
- 3.5.3 Through NICS, BellSouth will collect the revenue earned by Smart City Communications within the BellSouth territory from another LEC also within the BellSouth territory where the messages are billed, less a per message billing and collection fee of five cents (\$0.05), on behalf of Smart City Communications. BellSouth will remit the revenue billed by Smart City Communications within the BellSouth region to the LEC also within the BellSouth region, where the messages originated, less a per message billing and collection fee of five cents (\$0.05). These two (2) amounts will be netted together by BellSouth and the resulting charge or credit issued to Smart City Communications via a CABS miscellaneous bill on a monthly basis in arrears.
- 3.5.4 BellSouth and Smart City Communications agree that monthly netted amounts of less than fifty dollars (\$50.00) will not be settled.

## **Attachment 8**

### **Rights-of-Way, Conduits and Pole Attachments**

## **Rights-of-Way, Conduits and Pole Attachments**

BellSouth will provide nondiscriminatory access to any pole, duct, conduit, or right-of-way owned or controlled by BellSouth pursuant to 47 U.S.C. § 224, as amended by the Act, pursuant to terms and conditions of a separate license agreement negotiated with BellSouth.



**Attachment 9**  
**Service Quality Measurements**

## **SERVICE QUALITY MEASUREMENTS**

Upon a particular Commission's issuance of an order pertaining to Service Quality Measurements in a proceeding expressly applicable to all CLECs generally, BellSouth shall implement in that state such Service Quality Measurements as of the date specified by the Commission. Service Quality Measurements that have been ordered in a particular state can currently be accessed via the internet at <http://pmap.bellsouth.com>.

## Attachment 10

### BellSouth Disaster Recovery Plan

#### CONTENTS

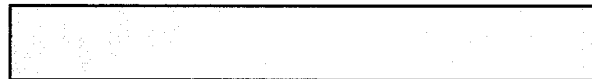

#### PAGE

1.0	Purpose	2
2.0	Single Point of Contact	2
3.0	Identifying the Problem	2
3.1	Site Control	3
3.2	Environmental Concerns	4
4.0	The Emergency Control Center (ECC)	4
5.0	Recovery Procedures	5
5.1	CLEC Outage	5
5.2	BellSouth Outage	5
5.2.1	Loss of Central Office	6
5.2.2	Loss of a Central Office with Serving Wire Center Functions	6
5.2.3	Loss of a Central Office with Tandem Functions	6
5.2.4	Loss of a Facility Hub	7
5.3	Combined Outage (CLEC and BellSouth Equipment)	7
6.0	T1 Identification Procedures	7
7.0	Acronyms	8

## **1.0 PURPOSE**

In the unlikely event of a disaster occurring that affects BellSouth's long-term ability to deliver traffic to a CLEC, general procedures have been developed by BellSouth to hasten the recovery process in accordance with the Telecommunications Service Priority (TSP) Program established by the FCC to identify and prioritize telecommunication services that support national security or emergency preparedness (NS/EP) missions. A description of the TSP Program as it may be amended from time to time is available on BellSouth's Interconnection Services Web site. Since each location is different and could be affected by an assortment of potential problems, a detailed recovery plan is impractical. However, in the process of reviewing recovery activities for specific locations, some basic procedures emerge that appear to be common in most cases.

These general procedures should apply to any disaster that affects the delivery of traffic for an extended time period. Each CLEC will be given the same consideration during an outage, and service will be restored as quickly as possible.

This document will cover the basic recovery procedures that would apply to every CLEC.

## **2.0 SINGLE POINT OF CONTACT**

When a problem is experienced, regardless of the severity, the BellSouth Network Management Center (NMC) will observe traffic anomalies and begin monitoring the situation. Controls will be appropriately applied to insure the sanity of BellSouth's network; and, in the event that a switch or facility node is lost, the NMC will attempt to circumvent the failure using available reroutes.

BellSouth's NMC will remain in control of the restoration efforts until the problem has been identified as being a long-term outage. At that time, the NMC will contact BellSouth's ECC and relinquish control of the recovery efforts. Even though the ECC may take charge of the situation, the NMC will continue to monitor the circumstances and restore traffic as soon as damaged network elements are revitalized.

**The telephone number for the BellSouth Network Management Center in Atlanta, as published in Telcordia's National Network Management Directory, is 404-321-2516.**

## **3.0 IDENTIFYING THE PROBLEM**

During the early stages of problem detection, the NMC will be able to tell which CLECs are affected by the catastrophe. Further analysis and/or first hand observation will determine if the disaster has affected CLEC equipment only, BellSouth equipment only or a combination. The initial restoration activity will be largely determined by the equipment that is affected.

Once the nature of the disaster is determined and after verifying the cause of the problem, the NMC will initiate reroutes and/or transfers that are jointly agreed upon by the affected CLECs' Network Management Center and the BellSouth NMC. The type and percentage of controls used will depend upon available network capacity. Controls necessary to stabilize the situation will be invoked and the NMC will attempt to re-establish as much traffic as possible.

For long-term outages, recovery efforts will be coordinated by the ECC. Traffic controls will continue to be applied by the NMC until facilities are re-established. As equipment is made available for service, the ECC will instruct the NMC to begin removing the controls and allow traffic to resume.

### **3.1 SITE CONTROL**

In the total loss of building use scenario, what likely exists will be a smoking pile of rubble. This rubble will contain many components that could be dangerous. It could also contain any personnel on the premises at the time of the disaster. For these reasons, the local fire marshal with the assistance of the police will control the site until the building is no longer a threat to surrounding properties and the companies have secured the site from the general public.

During this time, the majority owner of the building should be arranging for a demolition contractor to mobilize to the site with the primary objective of reaching the cable entrance facility for a damage assessment. The results of this assessment would then dictate immediate plans for restoration, both short term and permanent.

In a less catastrophic event, i.e., the building is still standing and the cable entrance facility is usable, the situation is more complex. The site will initially be controlled by local authorities until the threat to adjacent property has diminished. Once the site is returned to the control of the companies, the following events should occur.

An initial assessment of the main building infrastructure systems (mechanical, electrical, fire and life safety, elevators, and others) will establish building needs. Once these needs are determined, the majority owner should lead the building restoration efforts. There may be situations where the site will not be totally restored within the confines of the building. The companies must individually determine their needs and jointly assess the cost of permanent restoration to determine the overall plan of action.

Multiple restoration trailers from each company will result in the need for designated space and installation order. This layout and control is required to maximize the amount of restoration equipment that can be placed at the site, and the priority of placements.

Care must be taken in this planning to ensure other restoration efforts have logistical access to the building. Major components of telephone and building equipment will need to be removed and replaced. A priority for this equipment must also be jointly established to facilitate overall site restoration. (Example: If the AC switchgear has sustained damage, this would be of the highest priority in order to regain power, lighting, and HVAC throughout the building.)

If the site will not accommodate the required restoration equipment, the companies would then need to quickly arrange with local authorities for street closures, rights of way or other possible options available.

### **3.2 ENVIRONMENTAL CONCERNS**

In the worse case scenario, many environmental concerns must be addressed. Along with the police and fire marshal, the state environmental protection department will be on site to monitor the situation.

Items to be concerned with in a large central office building could include:

1. Emergency engine fuel supply. Damage to the standby equipment and the fuel handling equipment could have created "spill" conditions that have to be handled within state and federal regulations.
2. Asbestos-containing materials that may be spread throughout the wreckage. Asbestos could be in many components of building, electrical, mechanical, outside plant distribution, and telephone systems.
3. Lead and acid. These materials could be present in potentially large quantities depending upon the extent of damage to the power room.
4. Mercury and other regulated compounds resident in telephone equipment.
5. Other compounds produced by the fire or heat.

Once a total loss event occurs at a large site, local authorities will control immediate clean up (water placed on the wreckage by the fire department) and site access.

At some point, the companies will become involved with local authorities in the overall planning associated with site clean up and restoration. Depending on the clean up approach taken, delays in the restoration of several hours to several days may occur.

In a less severe disaster, items listed above are more defined and can be addressed individually depending on the damage.

In each case, the majority owner should coordinate building and environmental restoration as well as maintain proper planning and site control.

### **4.0 THE ECC**

The ECC is located in the Midtown 1 Building in Atlanta, Georgia. During an emergency, the ECC staff will convene a group of pre-selected experts to inventory the damage and initiate corrective actions. These experts have regional access to BellSouth's personnel and equipment and will assume control of the restoration activity anywhere in the nine-state area.

In the past, the ECC has been involved with restoration activities resulting from hurricanes, ice storms and floods. They have demonstrated their capabilities during these calamities as well as

during outages caused by human error or equipment failures. This group has an excellent record of restoring service as quickly as possible.

During a major disaster, the ECC may move emergency equipment to the affected location, direct recovery efforts of local personnel and coordinate service restoration activities with the CLECs. The ECC will attempt to restore service as quickly as possible using whatever means is available, leaving permanent solutions, such as the replacement of damaged buildings or equipment, for local personnel to administer.

Part of the ECC's responsibility, after temporary equipment is in place, is to support the NMC efforts to return service to the CLECs. Once service has been restored, the ECC will return control of the network to normal operational organizations. Any long-term changes required after service is restored will be made in an orderly fashion and will be conducted as normal activity.

## **5.0 RECOVERY PROCEDURES**

The nature and severity of any disaster will influence the recovery procedures. One crucial factor in determining how BellSouth will proceed with restoration is whether or not BellSouth's equipment is incapacitated. Regardless of whose equipment is out of service, BellSouth will move as quickly as possible to aid with service recovery; however, the approach that will be taken may differ depending upon the location of the problem.

### **5.1 CLEC OUTAGE**

For a problem limited to one CLEC (or a building with multiple CLECs), BellSouth has several options available for restoring service quickly. For those CLECs that have agreements with other CLECs, BellSouth can immediately start directing traffic to a provisional CLEC for completion. This alternative is dependent upon BellSouth having concurrence from the affected CLECs.

Whether or not the affected CLECs have requested a traffic transfer to another CLEC will not impact BellSouth's resolve to re-establish traffic to the original destination as quickly as possible.

### **5.2 BELLSOUTH OUTAGE**

Because BellSouth's equipment has varying degrees of impact on the service provided to the CLECs, restoring service from damaged BellSouth equipment is different. The outage will probably impact a number of Carriers simultaneously. However, the ECC will be able to initiate immediate actions to correct the problem.

A disaster involving any of BellSouth's equipment locations could impact the CLECs, some more than others. A disaster at a Central Office (CO) would only impact the delivery of traffic to and from that one location, but the incident could affect many Carriers. If the CO is a Serving Wire Center (SWC), then traffic from the entire area to those Carriers served from that switch would also be impacted. If the switch functions as an Access Tandem, or there is a tandem in the building, traffic from every CO to every CLEC could be interrupted. A disaster that destroys a facility hub could disrupt various traffic flows, even though the switching equipment may be unaffected.

The NMC would be the first group to observe a problem involving BellSouth's equipment. Shortly after a disaster, the NMC will begin applying controls and finding re-routes for the completion of as much traffic as possible. These reroutes may involve delivering traffic to alternate Carriers upon receiving approval from the CLECs involved. In some cases, changes in translations will be required. If the outage is caused by the destruction of equipment, then the ECC will assume control of the restoration.

### **5.2.1 Loss of a CO**

When BellSouth loses a CO, the ECC will

- a) Place specialists and emergency equipment on notice;
- b) Inventory the damage to determine what equipment and/or functions are lost;
- c) Move containerized emergency equipment and facility equipment to the stricken area, if necessary;
- d) Begin reconnecting service on a parity basis for Hospitals, Police and other emergency agencies or customers served by BellSouth or CLEC in accordance with the TSP priority restoration coding scheme entered in the BellSouth Maintenance database prior to the emergency.

### **5.2.2 Loss of a CO with SWC Functions**

The loss of a CO that also serves as a SWC will be restored as described in Section 5.2.1.

### **5.2.3 Loss of a CO with Tandem Functions**

When BellSouth loses a CO building that serves as an Access Tandem and as a SWC, the ECC will

- a) Place specialists and emergency equipment on notice;
- b) Inventory the damage to determine what equipment and/or functions are lost;
- c) Move containerized emergency equipment and facility equipment to the stricken area, if necessary;
- d) Begin reconnecting service on a parity basis for Hospitals, Police and other emergency agencies or customers served by BellSouth or CLEC in accordance with the TSP priority restoration coding scheme entered in the BellSouth Maintenance database prior to the emergency;
- e) Re-direct as much traffic as possible to the alternate access tandem (if available) for delivery to those CLECs utilizing a different location as a SWC;
- f) Begin aggregating traffic to a location near the damaged building. From this location, begin re-establishing trunk groups to the CLECs for the delivery of traffic normally



found on the direct trunk groups. (This aggregation point may be the alternate access tandem location or another CO on a primary facility route.)

#### **5.2.4 Loss of a Facility Hub**

In the event that BellSouth loses a facility hub, the recovery process is much the same as above. Once the NMC has observed the problem and administered the appropriate controls, the ECC will assume authority for the repairs. The recovery effort will include

- a) Placing specialists and emergency equipment on notice;
- b) Inventorying the damage to determine what equipment and/or functions are lost;
- c) Moving containerized emergency equipment to the stricken area, if necessary;
- d) Reconnecting service on a parity basis for Hospitals, Police and other emergency agencies or customers served by BellSouth or CLEC in accordance with the TSP priority restoration coding scheme entered in the BellSouth Maintenance database prior to the emergency; and
- e) If necessary, BellSouth will aggregate the traffic at another location and build temporary facilities. This alternative would be viable for a location that is destroyed and building repairs are required.

### **5.3 COMBINED OUTAGE (CLEC AND BELLSOUTH EQUIPMENT)**

In some instances, a disaster may impact BellSouth's equipment as well as the CLECs'. This situation will be handled in much the same way as described in Section 5.2.3. Since BellSouth and the CLECs will be utilizing temporary equipment, close coordination will be required.

### **6.0 T1 IDENTIFICATION PROCEDURES**

During the restoration of service after a disaster, BellSouth may be forced to aggregate traffic for delivery to a CLEC. During this process, T1 traffic may be consolidated onto DS3s and may become unidentifiable to the Carrier. Because resources will be limited, BellSouth may be forced to "package" this traffic entirely differently than normally received by the CLECs. Therefore, a method for identifying the T1 traffic on the DS3s and providing the information to the Carriers is required.

## 7.0 ACRONYMS

CLEC	-	Competitive Local Exchange Carrier
CO	-	Central Office (BellSouth)
DS3	-	Facility that carries 28 T1s (672 circuits)
ECC	-	Emergency Control Center (BellSouth)
NMC	-	Network Management Center
SWC	-	Serving Wire Center (BellSouth switch)
T1	-	Facility that carries 24 circuits
TSP	-	Telecommunications Service Priority

### **Hurricane Information**

During a hurricane, BellSouth will make every effort to keep CLECs updated on the status of our network. Information centers will be set up throughout BellSouth Telecommunications. These centers are not intended to be used for escalations, but rather to keep the CLEC informed of network related issues, area damages and dispatch conditions, etc.

Hurricane-related information can also be found on BellSouth's Interconnection Web site by clicking on the link "Relief Information" in the special alert box located on the Web page. Additionally, information concerning Mechanized Disaster Reports can also be found by clicking on the link "Click here for information concerning Disaster Recovery Reports" on the Hurricane Relief page.

### **BST Disaster Management Plan**

BellSouth maintenance centers have geographical and redundant communication capabilities. In the event of a disaster removing any maintenance center from service another geographical center would assume maintenance responsibilities. The contact numbers will not change and the transfer will be transparent to the CLEC.

## **Attachment 11**

### **Bona Fide Request and New Business Request Process**

**BONA FIDE REQUEST AND NEW BUSINESS REQUEST PROCESS**

1. **Bona Fide Request**
- 1.1 The Parties agree that Smart City Communications is entitled to order any Network Element, interconnection option or service option required to be made available by FCC or Commission requirements pursuant to the Act. A Bona Fide Request (BFR) is to be used when Smart City Communications makes a request of BellSouth to provide a new or modified Network Element, interconnection option or other service option pursuant to the Act that was not previously provided for in this Agreement.
- 1.2 A BFR shall be submitted in writing by Smart City Communications and shall specifically identify the requested service date, technical requirements, space requirements and/or such other specifications that clearly define the request such that BellSouth has sufficient information to analyze and prepare a response. Such a request shall also include Smart City Communications's designation of the request as being pursuant to the Telecommunications Act of 1996 (i.e., a BFR). The request shall be sent to Smart City Communications's designated BellSouth Sales contact or Local Contract Manager (LCM).
- 1.3 Within two (2) business days of receipt of a BFR, BellSouth shall acknowledge in writing its receipt and identify a single point of contact responsible for responding to the BFR and shall request any additional information needed to process the request to the extent known at that time. Notwithstanding the foregoing, BellSouth may reasonably request additional information from Smart City Communications at any time during the processing of the BFR.
- 1.4 Within thirty (30) business days of BellSouth's receipt of the BFR, if the preliminary analysis of the requested BFR is not of such complexity that it will cause BellSouth to expend extraordinary resources to evaluate the BFR, BellSouth shall respond to Smart City Communications by providing a preliminary analysis of the new or modified Network Element or interconnection option not ordered by the FCC or Commission that is the subject of the BFR. The preliminary analysis shall either confirm that BellSouth will offer access to the new or modified Network Element, interconnection option or service option or confirm that BellSouth will not offer the new or modified Network Element, interconnection option or service option.
- 1.5 For any new or modified Network Element, interconnection option or service option not ordered by the FCC or Commission, if the preliminary analysis states that BellSouth will offer the new or modified Network

Element, interconnection option or service option, the preliminary analysis will include an estimate of the costs of utilizing existing resources, both personnel and systems, in the development including, but not limited to, request parameters analysis, determination of impacted BellSouth departments, determination of required resources, project management resources, etc. (Development Rate) including a general breakdown of such costs associated with the Network Element, interconnection option or service option and the date the request can be met. If the preliminary analysis states that BellSouth will not offer the new or modified Network Element, interconnection option or service option, BellSouth will provide an explanation of why the request is not technically feasible, does not qualify as a BFR for the new or modified Network Element, interconnection option or service option, should actually be submitted as a New Business Request (NBR) or is otherwise not required to be provided under the Act. If BellSouth cannot provide the Network Element, interconnection option or service option by the requested date, BellSouth shall provide an alternative proposed date together with a detailed explanation as to why BellSouth is not able to meet Smart City Communications's requested date.

- 1.6 For any new or modified Network Element, interconnection option or service option not ordered by the FCC or Commission, if BellSouth determines that the preliminary analysis of the requested BFR is of such complexity that it will cause BellSouth to expend extraordinary resources to evaluate the BFR, BellSouth shall notify Smart City Communications within ten (10) business days of BellSouth's receipt of BFR that a fee will be required prior to the preliminary evaluation of the BFR. Such fee shall be limited to BellSouth's extraordinary expenses directly related to the complex request that require the allocation and engagement of additional resources above the existing allocated resources used on BFR cost development which include, but are not limited to, expenditure of funds to develop feasibility studies, specific resources that are required to determine request requirements (such as operation support system analysts, technical managers, software developers), software impact analysis by specific software developers; software architecture development, hardware impact analysis by specific system analysts, etc. and the request for such fee shall be accompanied with a general breakdown of such costs. If Smart City Communications accepts the complex request evaluation fee proposed by BellSouth, Smart City Communications shall submit such fee within thirty (30) business days of BellSouth's notice that a complex request evaluation fee is required. Within thirty (30) business days of BellSouth's receipt of the complex request evaluation fee, BellSouth shall respond to Smart City Communications by providing a preliminary analysis, consistent with Section 1.4 above.

- 1.7 Smart City Communications may cancel a BFR at any time up until thirty (30) business days after receiving BellSouth's preliminary analysis. If Smart City Communications cancels the BFR within thirty (30) business days after receipt of BellSouth's preliminary analysis, BellSouth shall be entitled to keep any complex request evaluation fee submitted in accordance with Section 1.6 above, minus those costs included in the fee that have not been incurred as of the date of cancellation.
- 1.8 Smart City Communications will have thirty (30) business days from receipt of preliminary analysis to accept the preliminary analysis or cancel the BFR. If Smart City Communications fails to respond within this thirty (30) business day period, the BFR will be deemed cancelled. Acceptance of the preliminary analysis must be in writing and accompanied by the estimated Development Rate for the new or modified Network Element, interconnection option or service option quoted in the preliminary analysis.
- 1.9 Notwithstanding any other provision of this Agreement, BellSouth shall propose a firm price quote, including the firm Development Rate, the firm nonrecurring rate and the firm recurring rate, and a detailed implementation plan within ten (10) business days of receipt of Smart City Communications's accurate BFR application for a Network Element, interconnection option or service option that is operational at the time of the request; thirty (30) business days of receipt of Smart City Communications's accurate BFR application for a new or modified Network Element, interconnection option or service option ordered by the FCC or Commission; and within sixty (60) business days of receipt of Smart City Communications's accurate BFR application for a new or modified Network Element, interconnection option or service option not ordered by the FCC or Commission or not operational at the time of the request. The firm nonrecurring rate will not include any of the Development Rate or the complex request evaluation fee, if required, in the calculation of this rate. Such firm price quote shall not exceed the estimate provided with the preliminary analysis by more than twenty-five percent (25%).
- 1.10 Smart City Communications shall have thirty (30) business days from receipt of firm price quote to accept or deny the firm price quote and submit any additional Development or nonrecurring rates quoted in the firm price quote.
- 1.11 Unless Smart City Communications agrees otherwise, all prices shall be consistent with the applicable pricing principles and provisions of the Act.
- 1.12 If Smart City Communications believes that BellSouth's firm price quote is not consistent with the requirements of the Act, either Party may seek

dispute resolution in accordance with the dispute resolution provisions set forth in General Terms and Conditions.

- 1.13 Upon agreement to the rates, terms and conditions of a BFR, the Parties shall negotiate in good faith an amendment to this Agreement.

## **2 New Business Request**

- 2.1 Smart City Communications also shall be permitted to request the development of new or modified facilities or service options which may not be required by the Act. Procedures applicable to requesting the addition of such elements, services and options are specified in this Attachment. A NBR is to be used by Smart City Communications to make a request of BellSouth for a new or modified feature or capability of an existing product or service, a new product or service that is not deployed within the BellSouth network or operations and business support systems, or a new or modified service option that was not previously included in this Agreement (Requested NBR Services) and is not required by the Act.
- 2.2 An NBR shall be submitted in writing by Smart City Communications and shall specifically identify the requested service date, technical requirements, space requirements and/or such specifications that clearly define the request such that BellSouth has sufficient information to analyze and prepare a response. The request shall be sent to Smart City Communications's designated BellSouth Sales contact or LCM.
- 2.3 Within two (2) business days of receipt of an NBR, BellSouth shall acknowledge in writing its receipt and identify a single point of contact responsible for responding to the NBR and shall request any additional information needed to process the request to the extent known at that time. Notwithstanding the foregoing, BellSouth may reasonably request additional information from Smart City Communications at any time during the processing of the NBR.
- 2.4 If the preliminary analysis of the requested NBR is not of such complexity that it will cause BellSouth to expend extraordinary resources to evaluate the NBR, within thirty (30) business days of its receipt of the NBR, BellSouth shall respond to Smart City Communications by providing a preliminary analysis of such Requested NBR Services that are the subject of the NBR. The preliminary analysis shall either confirm that BellSouth will offer access to the Requested NBR Services or confirm that BellSouth will not offer the Requested NBR Services.
- 2.5 If the preliminary analysis states that BellSouth will offer the Requested NBR Services, the preliminary analysis will include an estimate of the



Development Rate including a general breakdown of costs and the date the request can be met. If BellSouth cannot provide the Requested NBR Service by the requested date, it shall provide an alternative proposed date together with a detailed explanation as to why BellSouth is not able to meet Smart City Communications's requested date.

- 2.6 If BellSouth determines that the preliminary analysis of the requested NBR is of such complexity that it will cause BellSouth to expend extraordinary resources to evaluate the NBR, BellSouth shall notify Smart City Communications within ten (10) business days of BellSouth's notice that a complex request evaluation fee is required prior to the evaluation of the NBR. Such fee shall be limited to BellSouth's extraordinary expenses directly related to the complex request. If Smart City Communications accepts the complex request evaluation fee amount proposed by BellSouth, Smart City Communications shall submit such complex request evaluation fee within thirty (30) business days of BellSouth's notice that a complex request evaluation fee is required.
- 2.7 Within thirty (30) business days of BellSouth's receipt of the complex request evaluation fee, BellSouth shall respond to Smart City Communications by providing a preliminary analysis of such Requested NBR Services.
- 2.8 Smart City Communications may cancel an NBR at any time. If Smart City Communications cancels the request more than ten (10) business days after submitting it, Smart City Communications shall pay BellSouth's reasonable and demonstrable costs of processing and/or implementing the NBR up to the date of cancellation in addition to any fee submitted in accordance with Section 1.6 above.
- 2.9 Smart City Communications will have thirty (30) business days from receipt of the preliminary analysis to accept the preliminary analysis or cancel the NBR. If Smart City Communications fails to respond within this thirty (30) business day period, the NBR will be deemed cancelled.
- 2.10 Acceptance of the preliminary analysis must be in writing and accompanied by the estimated Development Rate for the Requested NBR Services quoted in the preliminary analysis.
- 2.11 BellSouth shall propose a firm price quote including the firm Development Rate, the firm nonrecurring rate, and the firm recurring rate, and a detailed implementation plan within ten (10) business days of receipt of Smart City Communications's accurate NBR application for a Requested NBR Service that is operational at the time of the request and within sixty (60) business days of receipt of Smart City Communications's accurate NBR application for the Requested NBR Services not operational

at the time of the request. The firm nonrecurring rate will not include any of the Development Rate or the complex request evaluation fee, if required, in the calculation of this rate. Such firm price quote shall not exceed the estimate provided with the preliminary analysis by more than twenty-five percent (25%).

- 2.12 Smart City Communications shall have thirty (30) business days from receipt of the firm price quote to accept or deny the firm price quote and submit any additional nonrecurring, non-refundable fees quoted in the firm price quote. If the firm price quote is less than the preliminary analysis' estimate of the Development Rate, BellSouth will credit Smart City Communications's account for the difference.
- 2.13 Upon agreement to the rates, terms and conditions of a NBR, an amendment to this Agreement, or a separate agreement, may be required and the Parties shall negotiate such agreement or amendment in good faith.