

ORIGINAL

AUSLEY & McMULLEN

ATTORNEYS AND COUNSELORS AT LAW

227 SOUTH CALHOUN STREET
P.O. BOX 391 (ZIP 32302)
TALLAHASSEE, FLORIDA 32301
(850) 224-9115 FAX (850) 222-7560

May 7, 2007

BY HAND DELIVERY

Ms. Ann Cole, Director
Division of Commission Clerk and
Administrative Services
Florida Public Service Commission
2540 Shumard Oak Boulevard
Tallahassee, Florida 32399-0850

RECEIVED
07 MAY -7 PM 12:48
COMMISSION
CLERK

070297

Re: Approval of Tampa Electric Company's Storm Hardening Plan
pursuant to Rule 25-6.0342, F.A.C.

Dear Ms. Cole:

Enclosed for filing in the above referenced are the original and seven (7) copies of Tampa
Electric Company's Petition for Approval of Storm Hardening Plan.

Please acknowledge receipt and filing of the above by stamping the duplicate copy of this
letter and returning the same to this writer.

Thank you for your assistance in connection with this matter.

Sincerely,

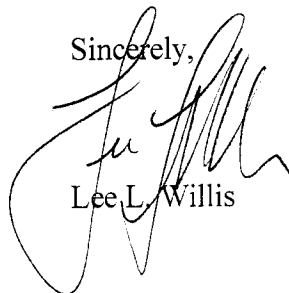

Lee L. Willis

- CMP _____
- COM _____
- CTR _____
- ECR _____
- GCL _____ LLW/bjd
- OFC _____ Enclosures
- RCA _____
- SCR _____
- SGA _____
- SEC _____
- OTH Pena

RECEIVED & FILED

FPSC-BUREAU OF RECORDS

DOCUMENT NUMBER-DATE

03821 MAY-7 5

FPSC-COMMISSION CLERK

BEFORE THE FLORIDA PUBLIC SERVICE COMMISSION

In re: Approval of Tampa Electric Company's)
Storm hardening plan pursuant to Rule)
25-6.0342, F.A.C.)
_____)

Docket No. 070297
Dated: May 7, 2007

**PETITION OF TAMPA ELECTRIC COMPANY
FOR APPROVAL OF STORM HARDENING PLAN**

Tampa Electric Company ("Tampa Electric" or the "company") hereby petitions the Florida Public Service Commission ("Commission") for approval of its 2007-2009 Storm Hardening Plan attached hereto as Exhibit 1 (the "Tampa Electric Plan" or "Plan"), which is submitted in compliance with Rule 25-6.0342, F.A.C. In support of this Petition, Tampa Electric states as follows:

1. Tampa Electric is a public utility subject to the regulatory jurisdiction of the Commission under Chapter 366, Florida Statutes. The company's principal offices are located at 702 North Franklin Street, Tampa, Florida 33601.

2. All notices, pleadings and other communications required to be served on the petitioner should be directed to:

Paula K. Brown
Administrator, Regulatory Affairs
Tampa Electric Company
Post Office Box 111
Tampa, Florida 33601
Telephone: (813) 228-1444

Lee L. Willis
James D. Beasley
Ausley & McMullen
Post Office Box 391
Tallahassee, Florida 32302
Telephone: (850) 425-5487

3. Subsection (2) of Rule 25-6.0342 requires each Florida investor-owned electric utility such as Tampa Electric to file a detailed storm hardening plan within ninety days of the rule's effective date. Pursuant to Order No. PSC-07-0043A-FOF-EI, issued in Docket Nos.

DOCUMENT NUMBER-DATE
03821 MAY-7 5
FPSC-COMMISSION CLERK

060172-EU and 060173-EU on January 17, 2007, Rule 25-6.0342 became effective on February 5, 2007. The filing deadline is thus May 7, 2007, and the Tampa Electric Plan is timely filed.

4. Subsections (3), (4) and (5) of Rule 25-6.0342 set forth the required elements of storm hardening plans. The Tampa Electric Plan contains all of the required elements.

5. Pursuant to Rule 25-6.0342(6), F.A.C., Tampa Electric sought input from all third party attachers, including local city governments, in the development process of its construction standards and third party attachment requirements contained in the Tampa Electric Plan.

6. In early 2007, Tampa Electric began the development of its Plan. On March 27, 2007, Tampa Electric conducted a meeting with all third party attachers in its service area to provide an initial overview of the company's proposed Plan. Those in attendance or who joined by conference call included representatives of Verizon, Embarq, Bright House Networks, Florida Cable Telecommunications Association ("FCTA"), the City of Oldsmar and the City of Plant City.

7. On April 11, 2007, Tampa Electric furnished its proposed Plan to all third party attachers who had previously requested to receive this communications from the company in order to have their input considered during the Plan development process. Tampa Electric requested any responses from attachers be submitted to the company by April 26, 2007. Tampa Electric received timely input from BellSouth Telecommunications, Inc., Florida Cable Telecommunications Association ("FCTA"), and the City of Oldsmar. Embarq provided input on May 3, 2007. Verizon was unable to provide input by the deadline but engaged Tampa Electric's engineering team for clarification and field observations of specific circuits scheduled for hardening. Based on the timely input received from the responding third party attachers, Tampa Electric made modifications to its Plan.

8. As Tampa Electric initiates its Plan, the company anticipates a mutually beneficial working relationship with the third party attachment community. The success of the Plan is dependent upon all entities striving for the common goal of cost-effectively hardening the infrastructure supporting the delivery of each company's services.

9. Tampa Electric urges the Commission to expeditiously approve the company's 2007-2009 Storm Hardening Plan as found in Exhibit "1" to this Petition.

WHEREFORE, Tampa Electric respectfully requests the Commission to approve Tampa Electric's storm hardening plan attached hereto as Exhibit "1".

Respectfully submitted this 7th day of May, 2007.

LEE L. WILLIS
JAMES D. BEASLEY
Ausley & McMullen
Post Office Box 391
Tallahassee, Florida 32302
(850) 425-5487

By:



Lee L. Willis

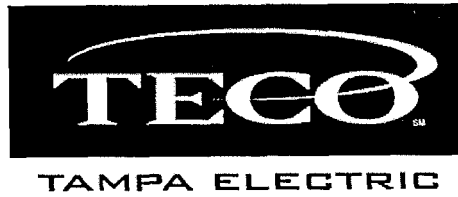

2007 – 2009
Storm Hardening Plan

Docket No. 060172-EI
Docket No. 060173-EI

Filed: May 7, 2007

Table of Contents

1	INTRODUCTION.....	5
2	PURPOSE.....	5
3	SCOPE	5
4	REFERENCES.....	6
5	DEFINITIONS.....	6
6	CONSTRUCTION STANDARDS, POLICIES, PRACTICES and PROCEDURES	7
6.1	Design Philosophy.....	7
6.1.1	Experience with Major Storm Events	10
6.1.1.1	2004 Hurricane Season.....	11
6.1.2	Distribution.....	13
6.1.2.1	Overhead System.....	14
6.1.2.2	Underground Facilities	16
6.1.2.3	Location of Facilities.....	19
6.1.2.4	Critical Infrastructure	19
6.1.2.5	Overhead to Underground Conversions	20
6.1.3	Transmission	21
6.1.3.1	Transmission Structures.....	21
6.1.3.2	Foundations.....	22
6.1.3.3	Design Criteria.....	23
6.1.4	Substation.....	24
6.1.4.1	Design Philosophy.....	24
6.1.4.2	Construction Standards.....	25
7	DEPLOYMENT STRATEGY.....	26
7.1	Construction Standards.....	26
7.2	Maintenance programs.....	27
7.2.1	Vegetation Management.....	27
7.2.2	Distribution Maintenance.....	27

7.2.2.1	Pole Replacements	27
7.2.3	Transmission Maintenance	28
7.2.3.1	Groundline Inspection	29
7.2.3.2	Ground Patrol	29
7.2.3.3	Aerial Infrared Patrol	30
7.2.3.4	Above Ground Inspection.....	30
7.2.3.5	Pre-Climb Inspections	31
7.2.3.6	Reporting	31
7.2.3.7	Pole Replacements	31
7.2.4	Substation Maintenance.....	32
7.3	Other Storm Hardening Initiatives	33
7.3.1	Downtown Network	33
7.3.2	Tampa International Airport.....	35
7.3.3	Conversion of remaining 4 kV distribution circuits	35
7.3.4	Overhead to Underground Conversion of Interstate Highway Crossings	35
7.3.5	Post-Storm Data Collection and Forensic Analysis.....	36
7.4	Extreme Wind Pilot Program	37
7.4.1	Port of Tampa.....	37
7.4.2	Saint Joseph’s Hospital	39
7.5	2007-2009 Deployment and Costs.....	40
7.5.1	Third Party Attacher Benefits and Impacts.....	41
8	ATTACHMENT STANDARDS AND PROCEDURES	43
8.1	Access to Tampa Electric poles	43
8.2	Permit Application Procedure.....	43
8.2.1	Permit Application Documentation	44
8.2.2	Permit Engineering Study Review.....	45
8.3	Make Ready	45
8.3.1	Make Ready Construction Not Required.....	45
8.3.2	Make Ready Construction Required by Tampa Electric	45

8.3.3	Make Ready Construction Required by Existing Third Party Attacher.....	46
8.4	Tampa Electric Post Inspection Process.....	46
8.4.1	Code Violations	47
8.5	National Joint Utility Notification System.....	47
8.6	Permit Closeout and Final Billing	48
8.7	Pole Inspection Program	48
8.8	Joint Use Pole Attachment Audit.....	49
	Attachment A.....	50
	Attachment B.....	59
	Attachment C	60
	Attachment D	61

1 INTRODUCTION

Tampa Electric's 2007 - 2009 Storm Hardening Plan is an important part of Tampa Electric's multi-pronged approach to enhance the reliability of the overhead and underground electrical transmission and distribution facilities and has been developed in conformance to Florida Public Service Commission ("FPSC") Order No. PSC-07-0043-FOF-EU issued January 16, 2007.

Tampa Electric serves 654,000 customers and its service area covers 2,000 square miles in West Central Florida, including all of Hillsborough County and parts of Polk, Pasco and Pinellas Counties. Tampa Electric's transmission system consists of approximately 1,200 miles of overhead facilities (26,000 poles) and 14 miles of underground facilities. The company's distribution system consists of approximately 6,100 miles of overhead lines (303,000 poles) and 7,300 miles of underground lines. Tampa Electric also has approximately 330,000 authorized third party attachments on its transmission and distribution poles.

2 PURPOSE

The purpose of this plan is to define the design criteria, construction standards, policies and procedures utilized for all new transmission, distribution and substation facilities constructed in Tampa Electric's service territory. This plan will also describe in detail the company's deployment strategy to achieve the plan's objectives, which include the costs and benefits expected, and the benefits and impacts to third party attachers. Finally, the plan will outline the company's pole attachment standards and procedures for third party attachers ("joint users").

3 SCOPE

This plan is intended to apply to all new construction and maintenance of transmission, distribution and substation facilities by Tampa Electric in its service territory and all third parties who access and attach to Tampa Electric facilities subsequent to the Commission-approved date of the plan.

4 REFERENCES

The following resources are referenced in this plan:

- 2007 National Electrical Safety Code (“NESC”)
- National Hurricane Center Database
- Florida State Building Code
- Hillsborough County Wind Maps
- Tampa Electric’s 2006 Storm Implementation Plan
- *Distribution Engineering Technical Manual (“DETM”)*
- *Standard Electrical Service Requirements (“SESR”)*
- *General Rules and Specifications (“GR&S”)*
- *General Rules and Specifications Underground (“GR&S-UG”)*
- *Approved Materials Catalog (“AMC”)*
- *Hillsborough County Flood Hazard Maps*

5 DEFINITIONS

Transmission – electric facilities operating at 69 kV or above.

Distribution – electric facilities operating below 69 kV.

Chromated copper arsenate (“CCA”) - A chemical wood preservative containing chromium, copper and arsenic. CCA is used in pressure treated wood to protect wood from rotting due to insects and microbial agents.

ACSR (aluminum conductor, steel reinforced) - ACSR conductor, a stranded steel core carries the mechanical load, and layers of stranded aluminum surrounding the core carry the current.

AAAC - All aluminum alloy conductor.

Attachers – Any entity that has placed any facility on a Tampa Electric owned pole. Facilities may include but are not limited to cables, messenger wires, centenary support wires, power supplies, equipment boxes, grounding wires or lugs, brackets, guys, etc.

6 CONSTRUCTION STANDARDS, POLICIES, PRACTICES and PROCEDURES

6.1 Design Philosophy

A basis of Tampa Electric's construction standards, policies, practices and procedures is the NESC. From this foundation, the company's philosophy is to implement the safest, reliable and most cost effective service possible to its customers. The two main elements of the NESC address minimum clearances and loading criteria required to maintain a safe system for both the public and the workers who construct and maintain the system. Tampa Electric's construction standards and policies meet or exceed all minimum NESC clearance requirements. In addition, as part of the NESC Rule 250 which addresses pole loading requirements, the United States is divided into three loading districts; Heavy, Medium and Light (see Fig. 1). The Tampa Electric service area is located in the Light loading district, which assumes no ice build up and with a wind pressure of nine pounds per square foot. The nine pound wind corresponds to approximately 60 mph. The Light loading district wind speed corresponds to a wind pressure of more than twice that in the Heavy or Medium districts due to the strong (non-linear) dependence of the wind force on wind speed (The wind pressure is proportional to the square of the wind speed.). Another part of the NESC Rule 250B requires overload factors to be applied to the calculated wind forces to provide a conservative margin of safety when selecting appropriate pole sizes. A factor of two to one is applied to Grade C construction and a factor of four to one is applied to Grade B construction. The effective wind speed of Grade B new construction is approximately 116 mph. According to the NESC, Grade B wind

loading criteria must be applied when constructing facilities less than 60 feet in height when crossing railroads, bridges and highways.

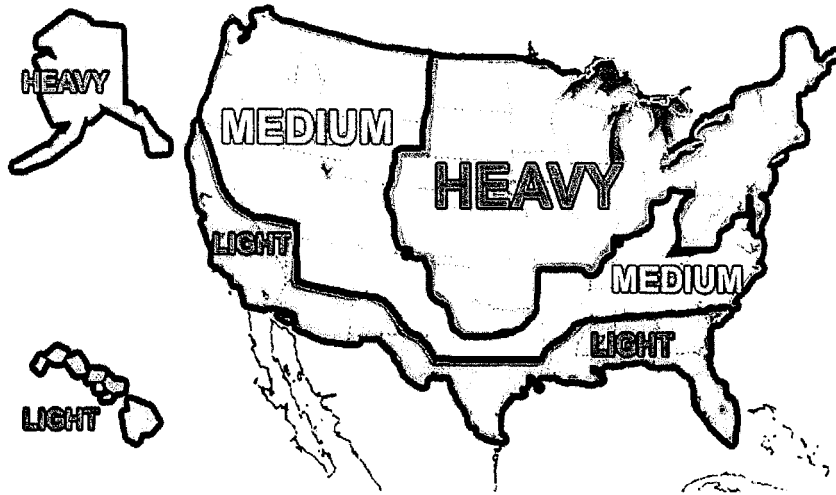

Fig.1- NESC General loading map of United States with respect to loading of overhead lines

The NESC also specifies an extreme wind pole loading criteria for all facilities constructed that are 60 feet in height or greater. The NESC provides a wind loading map that indicates the wind speed criteria for each area of the country. This same criteria and regional boundaries, developed by the American Society of Civil Engineers (“ASCE”), are utilized by the state of Florida and Hillsborough County for building code requirements. Tampa Electric’s service territory is divided into two wind regions (see Fig. 2). The western half is in 120 mph zone and the eastern half is

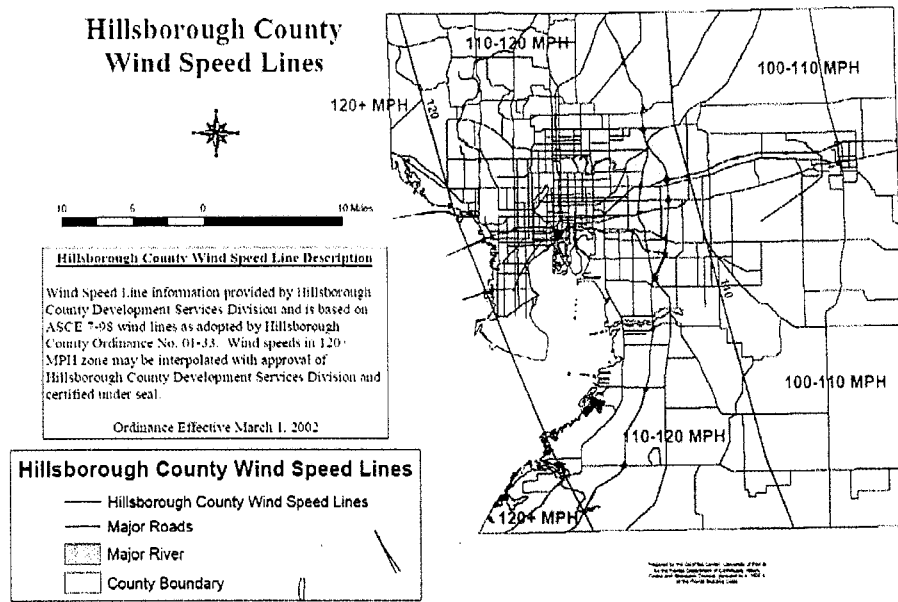

Fig. 2 - Hillsborough Wind-Borne Debris Region

in the 110 mph zone. It should also be noted that the Florida Building Code wind-borne debris region shown in Fig. 3 is the area where winds are greater than 120 mph. This wind-borne debris region is located outside of Tampa Electric's service territory.

State of Florida

Wind-Borne Debris Region

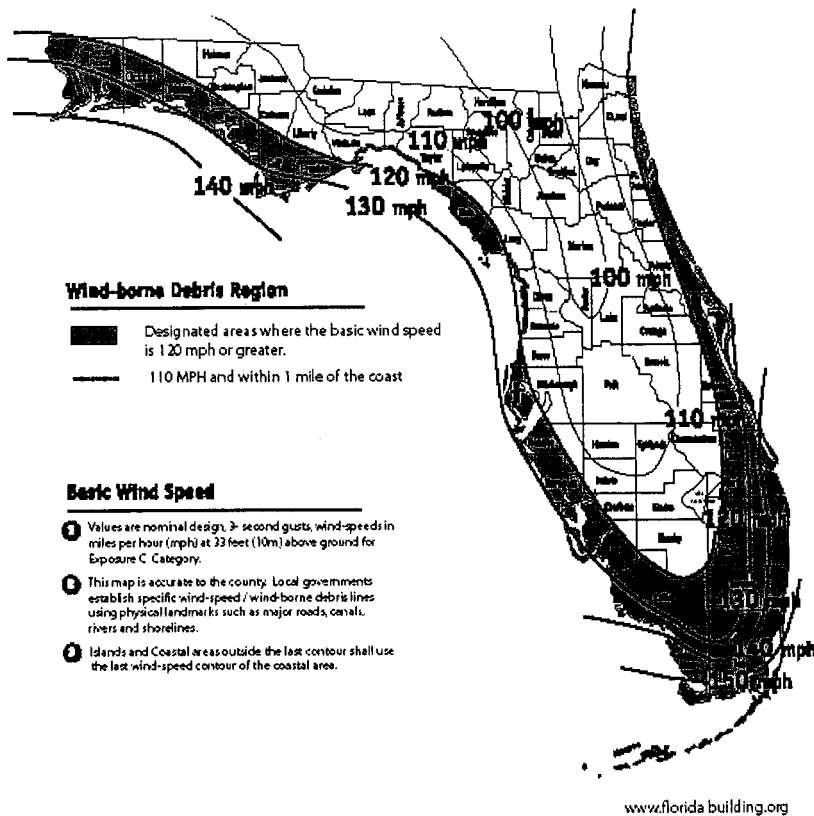

Fig. 3 - Florida Wind-Borne Debris Region

6.1.1 Experience with Major Storm Events

The company relies heavily on its experiences when developing and modifying its construction standards, policies, practices and procedures. A major component of this philosophy is experiences gained from major storm events and evaluations of system performance and the following restoration activities. In the last 150 years, the

company has experienced 14 major storm events, including five tropical storms, four category one hurricanes, three category two hurricanes, and two category three hurricanes (see Table 1). The highest sustained hurricane winds the Tampa Electric service area has experienced over this time is the 115 mph winds produced by the category 3 storms in 1949 and again in 1960.

Year	Storm Name	Size	Wind Speed (mph)
1852	Not Named	TS	69
1894	Not Named	Cat 1	86
1910	Not Named	Cat 1	80
1921	Not Named	Cat 2	97
1925	Not Named	TS	69
1933	Not Named	TS	63
1945	Not Named	Cat 2	97
1946	Not Named	TS	46
1949	Not Named	Cat 3	115
1960	Donna	Cat 3	115
1995	Erin	TS	57
2004	Charley	Cat 2	86
2004	Francis	Cat 1	63
2004	Jeanne	Cat 1	63

Table 1. Storms affecting Tampa Electric Service area since 1850 (From the National Hurricane Center Database)

6.1.1.1 2004 Hurricane Season

As demonstrated by the graphic in Fig. 4, Tampa Electric was clearly in an unenviable geographic location during the 2004 hurricane season, directly in the path of hurricanes Charley, Frances and Jeanne. Hurricane Ivan, while it did not pass over Tampa Electric's area, posed significant challenges for the company's fuels management operations, with major natural gas supplies effectively shut down on the Gulf of Mexico. This unprecedented hurricane season was the most devastating in Tampa Electric's 105-year history, both in terms of structural damage to the company's system and in terms of customer outages. Records were made and broken, day after day, as three successive hurricanes ravaged the company's 2,000 square-mile service territory.

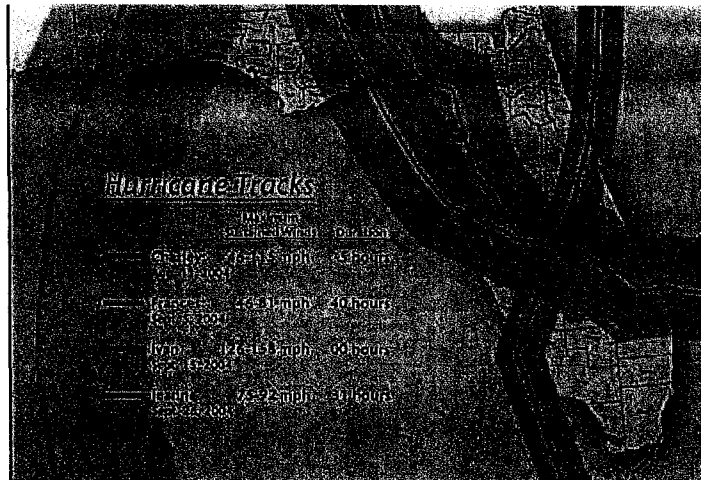

Fig. 4 – 2004 hurricanes impacting Tampa Electric’s service territory

It started August 13, 2004 as the company’s Polk County service area endured a substantial lashing from Hurricane Charley. Tampa Electric had been spared many direct hits from storms of this severity and for most involved in restoration, it was the first time the incident command system had been fully implemented. Operationally, the prognosis for Hurricane Charley was even more complicated – unusual amounts of rainfall earlier in the season had weakened the ground and made it unstable, inviting increased damage. Ultimately, the peak outages numbered 78,000 and the company restored its customers within five days. Hurricane Frances, which struck Tampa Electric on September 5, 2004, posed a different and more significant threat, as it passed over the more populous areas within Tampa Electric’s service territory. Making matters worse, the storm lingered, staying over the company’s territory for 39 hours. The outage toll was much higher than that of Charley – 268,000 peak outages and the company restored all 268,000 customers within seven days. Hurricane Frances’ impact was approximately 95 percent tree- or limb-related. The most impact of any storm, however, came from the third and most unexpected storm of the season – Hurricane Jeanne. Jeanne made a late turn, changing its path substantially in the last hours before landfall. The late turn put Tampa Electric’s entire service territory within the storm’s reach. Jeanne caused the most extensive structural damage to Tampa Electric’s system, with 64 transmission structures down, compared with 31

during Hurricane Charley and 14 during Hurricane Frances. The company was faced with restoring 55 percent of its transmission system. Further complicating Hurricane Jeanne was the initial unavailability of foreign linemen and tree trimmers, who were tapped out working on continued restoration from the previous storms in Florida and throughout the Southeast. Overall, Hurricane Jeanne presented the most outages experienced at a single time in Tampa Electric's history. Thanks to the early and determined response of Tampa Electric's workers and the additional assistance the company received mid-restoration, the 285,000 customers were all restored within seven days.

As a result of these three hurricanes; a total of 2,721 distribution poles were replaced or an average of 0.3% per storm and a total of 110 transmission poles were replaced or an average of 0.14% per storm.

6.1.2 Distribution

This section of the plan builds upon the design philosophy discussed above and provides an overview of the design criteria, construction standards and practices applicable to all new distribution facilities. This section also presents a broad discussion of distribution materials and structure types utilized.

Tampa Electric has developed and maintains a *DETM* which provides corporate and field personnel the policies, procedures and technical data related to the design of distribution facilities owned and operated by the company. Information contained in this manual along with the *SESR*, *GR&S*, *GR&S-UG* and *AMC*, provide guidelines for designing, constructing and maintaining Tampa Electric's distribution system.

6.1.2.1 Overhead System

Voltage

Tampa Electric's standard distribution feeder system operates at 13.2 kV three-phase primary voltage. The company does have three circuits operating at 4 kV primary voltage.

Clearances

Primary voltage conductors are located in the power space on the pole which is the upper most portion of the pole as defined by the NESC. Secondary and service conductors along with the neutral are located approximately six feet lower than the primary conductors. Joint attachers are located in the communication space on the pole which is approximately 40 inches below the neutral cable or Tampa Electric communication cable. Additional facilities may also exist on the same pole (i.e., in the form of a second distribution circuit) in which case the company adheres to all NESC clearance and loading requirements. For typical clearances applicable to joint use attachments, see Attachment A.

Pole Loading

Tampa Electric utilizes NESC Grade B loading criteria as the basis for its construction standard for all new construction, major planned work, expansions, rebuilds and relocations on the overhead distribution system. As described in Section 6.1 above, the safety factors considered in the NESC Grade B criteria provide for a system that is twice as strong as the NESC Grade C criteria which results in a robust design that the company's experience has shown to provide safe, reliable and cost effective service. This standard exceeds the minimum requirement of the NESC, which requires distribution poles to be designed based on a minimum of 60 mph wind speeds. Tampa Electric requires that all distribution facilities be designed to the highest applicable NESC requirement, which is 50 percent stronger than the minimum NESC requirements. While the NESC has requirements related to extreme

wind conditions, these requirements are only for structures over 60 feet in height and rarely apply to distribution structures.

Tampa Electric's experience continues to show that there is no substantial evidence that building distribution structures to extreme wind construction grades will prevent damage from falling trees, tree limbs and flying debris during major storm events. Tampa Electric has concluded from its storm restoration experience and historical hurricane exposure that Grade B construction, which will withstand an effective wind speed between 116 mph (new construction) and 95 mph (at replacement), is the most cost effective and reliable standard for the company's service area.

Materials

There are several types of poles that are used for distribution structures. Tampa Electric's distribution system consists of wood, concrete, steel and fiberglass poles. The standard for all new construction is wood poles that are treated with CCA or Penta poles for rear lot maintenance pole replacements.

The company's standard conductor for circuit feeders is 336 kcmil ACSR with a 2/0 AAAC neutral. Conductor sizes utilized for distribution laterals (overhead takeoffs from feeders) may either be #2, 2/0 or 4/0 AAAC with some older existing facilities containing #6 copper conductor.

Construction Types

Proper configuration selection is emphasized for maintenance, safety and economics. The existing line configuration should be maintained on multi-phase line extensions. Distribution facilities shall not be rebuilt or replaced for the sole purpose of appearance, unless paid for by the customer.

Triangular line configuration using fiberglass brackets is the preferred construction standard. It is the most economical to install and is particularly suited to situations involving restrictive rights-of-way, easements and clearances. Because of its narrow

profile, it should be used for locations with numerous trees. Other construction types that may be used include vertical, modified vertical and wood crossarm.

Pole Loading Compliance

A new process was implemented in 2007 that will assure Tampa Electric is in compliance with all NESC loading requirements and company construction standards. Tampa Electric adopted the use of a pole loading software program, “PoleForeman”, as part of this implementation. The program utilizes the company’s construction standards (templates) to model each pole and assist company field engineering technicians. The technician inputs the appropriate template, conductor, pole size and class, which the program uses to determine all loads on the pole. The program applies them to the structure and calculates the resulting stresses as a percent loaded.

6.1.2.2 Underground Facilities

Standard Design

Tampa Electric’s standard underground distribution system consists of normally looped circuits operating at 13.2 kV three-phase or 7.6 kV single-phase primary voltages. The standard cable is 15 kV strand filled jacketed tree retardant cross-linked polyethylene (TRXLPE) insulated aluminum cable with a copper concentric neutral. Tampa Electric’s standard is to place all underground distribution cables in a conduit system buried with 24 to 36 inches of ground cover. Since 2004, all primary switchgear has been specified using stainless steel enclosures to reduce the corrosion effects from salt spray and affluent irrigation spray. All padmounted transformers have been specified utilizing stainless steel in the skirt, door and hinges while the tank is made of a mild steel material.

Network Service

Tampa Electric has two types of underground facilities: standard underground facilities used in residential subdivisions and commercial areas described above and

network service. Network service provides a high level of reliability and operating flexibility. The company utilizes two types of network service: an integrated secondary grid network that serves the high-density load area in downtown Tampa, and spot network systems that serve high-density load in the downtown Tampa network area and the Tampa International Airport. The network system provides redundant feeds and thus is designed to maintain service during a first contingency outage. The network system is somewhat waterproof and can be located in vaults, some of which are below grade. However, the customer owned electrical panels are not waterproof and will likely be severely impacted by saltwater intrusion.

Construction Standards in Coastal Areas

Part of Tampa Electric's service area is bounded by Tampa Bay and has approximately 60 square miles of land in the Flood Zone 1 designated area as defined in Hillsborough County's Hazard Flood Maps. Along these coastal areas, there is increased risk of storm surge, flooding and saltwater contamination. While a good portion of this land is wetlands and is not build-able, the company has instituted higher design and construction standards in this area. The company's proposed standard is that all new underground distribution facilities (padmounted transformer, switchgear, load break cabinets and padmounted capacitors), located in the Flood Zone 1 designated area, shall be of stainless steel or aluminum construction and bolted to the concrete pad. Upgrading the material from mild steel to stainless steel or aluminum is more durable and typically extends equipment life after saltwater contamination; however, the equipment is not waterproof and will require cleaning following a flooding event prior to re-energizing. Any maintenance replacements in this designated area shall also be replaced with a stainless steel or aluminum equivalent.

Procedures Following Flooding Events

The company has considered two scenarios that could occur in these flood prone areas. The first scenario, and the most catastrophic event, would be a Category 3 hurricane or greater with a storm surge of 12 feet or greater producing high crushing water, sand and debris. In this event, the company anticipates everything in the storm

surges path would be moved or buried, as was the case in the aftermath of Hurricane Ivan in Gulf Power's utility system. The result was no load to serve for an extended time after the storm surge. In light of this experience, Tampa Electric has concluded that it is not practical or cost effective to attempt the design of an underground system to withstand such an event.

The second scenario is a flooding event where the water rises up to five feet during a Category 1 hurricane. In this event, there is simply the high water without the accompanying storm surge. In most cases and depending on the level of water, there may not be any load to serve immediately; however, the buildings, houses, etc., will still be standing and may or may not be habitable.

Tampa Electric recognizes there is a significant chance that some equipment may become submerged or flooded during a storm. Although specific locations and severity of flooding cannot be pre-determined, Tampa Electric may choose to de-energize portions of its system if it is in the public's best interest and can be done safely. Tampa Electric will also de-energize portions of its system if directed by the appropriate governing authorities. Prior to re-energizing flooded switchgear and padmounted transformers, the underground equipment will be visually inspected and cleaned with fresh water if saltwater intrusion has occurred. The switchgear fuses will be replaced if the flood levels exceeded the height of the fused barrels. All meters that have been submerged will be replaced prior to re-energizing. If a replacement is not immediately available, the customer's meter may be bypassed. The service can be re-energized after the customer requests it and only after the water has receded and the meter socket and main disconnect have been visually inspected. Tampa Electric's inspection jurisdiction is limited to the meter, meter socket and main disconnect.

Major storms can cause damage to customer owned equipment as well, such as pipe mast, switchgear, or meter socket, and to the degree that service is discontinued. In this case, Tampa Electric will notify the affected customer that service cannot be restored until the customer secures the services of an electrical contractor to make the appropriate repairs.

6.1.2.3 Location of Facilities

Tampa Electric's policy is to place all new distribution facilities in public right-of-way ("ROW"), which is typically in the front of the customer premises, and not to build in rear lot easements. The company clearly recognizes that limited access to facilities located behind the customer's premises significantly increases restoration time. This frontal approach facilitates efficient access during installation and maintenance of the facilities. Prior to 1970 and this policy, distribution facilities were constructed in rear lot easements. From time to time, communities or homeowner associations make inquiries regarding the relocation of overhead facilities from rear lot locations to the front of customers' properties. Tampa Electric evaluates each inquiry on a case-by-case basis for feasibility, practicality and cost effectiveness. Consideration is given to the impact of any tree trimming required along the front of the property (aesthetics), conversion costs, joint attacher cost impacts and scheduling, ROW availability, customer's service main locations and the availability of front access to the dwelling or building.

Should a major storm impact Tampa Electric's service area, the company will evaluate opportunities that may present themselves to relocate rear lot facilities to the front of property as a better alternative than attempting to replace downed facilities in the original rear lot easement. In this situation, customer and third party attacher (if present) consensus must be quickly collected so as not to delay restoration.

6.1.2.4 Critical Infrastructure

Tampa Electric has identified its critical infrastructure as those circuits feeding loads which are critical to the maintenance of basic services that include: public health (water and sewage, fire, hospitals), distilled fuels (refinery, tank farm) and transport hubs (airports). These circuits have the highest restoration priority level. Examples of these types of customers in Tampa Electric's service territory include the Tampa

International Airport, hospitals, Port of Tampa, County and City Emergency Operations Centers, key police and fire stations, and major water and sewage pumping facilities. Over the next three years, Tampa Electric plans to harden three circuits which feed some of the most critical customers on the company's system to extreme wind criteria. These projects will be part of a pilot program, set up to evaluate the benefits of utilizing the NESC extreme wind loading requirements on the distribution system, and are described in more detail in the Deployment Strategy section of the plan.

6.1.2.5 Overhead to Underground Conversions

Tampa Electric will evaluate community, governmental agency and homeowner association requests to convert existing overhead power lines to underground. Each inquiry will be evaluated on a case by case basis for feasibility, practicality and cost impact. Consideration will be given to conversion costs, ROW availability for underground facilities, physical constraints, additional customer cost associated with service main conversion from overhead to underground, joint attacher impact cost, scheduling and coordination.

Tampa Electric developed Table 2 to illustrate the benefits and drawbacks associated with both overhead and underground electric service.

Overhead		Underground	
Benefits	Drawbacks	Benefits	Drawbacks
Lower cost to install and maintain	Overhead lines tend to have more power outages primarily due to trees coming in contact	Better aesthetics	Difficult and longer to trouble shoot outages
Easier to restore and locate faults	Higher exposure due to wind impact	Less exposure to high winds and reduced outages due to animals	More costly to restore/repair outages (four times) ¹
Shorter duration of power outages	Accidental contacts from antennas and aluminum gutter installations	No tree trimming expense	More exposure due to storm surge or flooding
Overhead facilities have more operational flexibility, e.g.,	High exposure in traffic areas, roadways, easements	Property values tend to be higher	More costly to install and maintain. Up to ten times the cost of new overhead power line ² and

Overhead		Underground	
Benefits	Drawbacks	Benefits	Drawbacks
adding transformer, tapping lateral			higher cost upgrading existing underground facilities due to expansion
Higher life expectancy	Poor aesthetics	Reduce risk of electrocutions due to antennas and aluminum gutter installations	40 year old overhead lines have better reliability than 20 year old underground lines ¹

Table 2. Summary of benefits and drawbacks of overhead and underground electric service

1. From the North Carolina Utilities Commission, November 2003, Feasibility of Placing Electric Distribution Facilities Underground
2. From the Edison Electric Institute, 2004, *Out of Sight, Out of Mind, A study on the costs and benefits of undergrounding overhead lines.*

6.1.3 Transmission

This section of the plan provides an overview of design considerations and references when performing a transmission structure analysis for new and existing facilities. This section is a broad discussion of transmission structure types, foundation design and design criteria.

6.1.3.1 Transmission Structures

Voltage levels

Tampa Electric's transmission system consists of circuits operating at 230 kV, 138 kV and 69 kV voltages. These circuits constitute a minimum of three-phase conductors and a static wire (ground). Additional facilities may exist or be incorporated in the design of a transmission structure. These include additional transmission circuits, optical ground wire, distribution circuits and a conglomeration of wire attachments by joint attachers.

Material types

There are several types of materials that are utilized for transmission structures. Tampa Electric's transmission system consists of wood, concrete, aluminum and steel support structures. Past practices utilized wood pole, aluminum and lattice steel structure design. Pre-stressed spun concrete and tubular steel technology is now the preferred method. Since 1991, Tampa Electric has adopted a standard that all new

construction, line relocations and maintenance replacements will require a pre-stressed spun concrete or steel pole replacement.

Configuration Types

There are multiple transmission structure configurations utilized. Prior to pre-stressed spun concrete and tubular steel technology, typical structure configurations commonly consisted of single wood structures, multi wood structures, wood H-frames, lattice aluminum H-frames and lattice steel towers. The advent of pre-stressed spun concrete and tubular steel poles has permitted a more cost effective, low maintenance and high strength option. The pre-stressed spun concrete poles and tubular steel poles are utilized in multiple configurations. Typical configurations utilizing these poles are single pole, multi pole and H-frame structures.

The configurations will vary widely when considering the many variables attributed to transmission facilities. Some of these variables are: number of circuits, conductor size, span length, soil conditions, ROW width, potential permitting requirements, utilization of adjacent land, environmental impacts, electric and magnetic field criteria, aesthetics, economics and community input. Single pre-stressed spun concrete or tubular steel structure configurations have proven to be the most economical and maintainable choice given the work environment and constraints encountered while engineering and constructing transmission facilities.

6.1.3.2 Foundations

Drilled shaft and direct embedment are the two preferred foundation types utilized for pre-stressed spun concrete or tubular steel structures. A drilled shaft typically has a specified depth, diameter, steel rebar cage, poured concrete and bolted flange plate for the pole base. A direct embedded foundation typically has a specified depth and diameter. The direct embedded foundation also requires that a segment of the superstructure to be embedded below ground, acting as part of the foundation, with natural backfill, crushed rock backfill or poured concrete backfill.

Tampa Electric uses a modified Broms foundation analysis for overturning foundation design. It is imperative that soil borings are collected or standard penetration tests are conducted to compile the appropriate soil data for foundation analysis. Tampa Electric's service area is regional and ground conditions are considered to be mostly sandy soil; however, soil is non-homogeneous and can vary greatly. It is also assumed that the water table is at grade which has a significant impact on soil strength, but remains a good assumption given the environment of Tampa Electric's service area.

6.1.3.3 Design Criteria

There are two types of methodologies used to analyze pole strength. Tampa Electric uses the ultimate strength analysis for all wood and non-wood structures. However, it is acceptable and often recommended to use the working stress method for wood poles.

Tampa Electric designs and specifies all transmission facilities in accordance with the latest version of the NESC. All designs address extreme wind, Grade B construction. The extreme wind loads are applied to all attachments on the transmission structure regardless of attachment height.

Tampa Electric's service area is largely within the 100 mph to 120 mph extreme wind contours referenced in the NESC. The company has concluded that the 120 mph wind standard will be applied on all 69 kV and 138 kV structures throughout Tampa Electric's service area. It has also been determined to continue the past practice of applying a 133 mph wind standard to all 230 kV structures throughout Tampa Electric's service area. The 133 mph wind standard exceeds the NESC requirements for extreme wind loading. This standard was adopted when Tampa Electric commissioned the first 230 kV line in its service area and the company continues to support the 133 mph wind standard as the best practice for 230 kV construction.

Since the inception of the NESC extreme wind standard, it has been applied to all Tampa Electric transmission facilities. However, the company has always applied a 133 mph wind standard to all 230 kV facilities.

6.1.4 Substation

Tampa Electric designs, constructs and maintains transmission and distribution substations and switchyards ranging from 13.2 kV to 230 kV with 217 existing substations. This includes performing siting studies, physical design, grading and drainage, foundation design, layout and design of control buildings, structure design and analysis, protection and control systems, and preparation of complete specifications for material, equipment and construction.

6.1.4.1 Design Philosophy

Wind Strength Requirements

Tampa Electric designs its substations in accordance with the latest approved version of the NESC. Currently, all distribution substation structures are designed to withstand a wind load of 120 mph.

At 230 kV generation facilities and 230 kV transmission stations, current design standards call for terminal line structures to withstand 133 mph wind loading along with the line tension of the transmission circuit.

The design standards summarized above meet the NESC loading criteria for extreme wind, Grade B construction. As previously stated, Tampa Electric's service area is within the 100 to 120 mph extreme wind contours referenced in the NESC.

Protection

Animal protection covers are installed on all 13 kV bushings, lightning arrestors, switches and leads. This helps prevent outages caused by animals and will also reduce damage from debris that may get inside the substation during a major storm event. Tampa Electric uses circuit switchers instead of fuses or ground switches on

new and upgraded transformer installations. This design will clear a fault much quicker, which minimizes damage and greatly reduces restoration time.

Other

Equipment elevations will be carefully evaluated when building on existing sites or when selecting future sites in the Flood Zone 1 designated area. Information on past flooding and potential future storm surge levels will be evaluated. Much equipment is built on steel supports and is above expected flood levels. Some equipment such as transformers can be submerged up to the point of attached cabinets and controls. Therefore the major focus will be on the elevation and water resistance of the control cabinets and related equipment. The sites and/or equipment will be elevated based on the overall site permitting that must be done with the governmental and environmental agencies taking into consideration the surrounding area.

6.1.4.2 Construction Standards

In a typical new distribution substation, the structures are of a galvanized tubular steel design. The tallest structure is approximately 24 feet above grade, with the majority of the structures and equipment being below 17 feet. Distribution feeder circuits are designed to exit the substation via underground cables installed inside six-inch conduit.

Control buildings are installed in 230 kV substations and 69 kV switching stations. These buildings are typically of concrete block construction with poured concrete columns and concrete roof panels, which are designed to withstand winds of 120 mph without any damage to the building or the equipment, housed inside. Recently the company design standard has been increased to 150 mph.

Chain link perimeter fences, depending on height and type of construction, have been designed to withstand 100 to 120 mph winds. Current fences are being designed for 120 mph. Perimeter walls are designed in accordance with the Florida Building Code, 125 mph wind load, Exposure B. Tampa Electric installs eight-foot tall perimeter chain link fences or walls, which exceed the NESC minimum height of

seven feet. This provides additional protection from wind-blown debris. Tampa Electric is also evaluating alternative types of fences that may be more effective in blocking debris.

7 DEPLOYMENT STRATEGY

Tampa Electric's storm hardening plan's deployment strategy will enhance system reliability and reduce storm restoration costs. The deployment strategy includes: 1) the implementation of the construction standards outlined above for all new transmission, distribution and substation facilities, 2) various maintenance programs that will strengthen and upgrade the system to current standards, 3) other storm hardening initiatives as outlined in Tampa Electric's 2006 Storm Implementation Plan filed March 2, 2007 and 4) establishment of a three-year program that will pilot the extreme wind loading standard for select targeted distribution facilities serving critical infrastructure within the company's service territory.

7.1 Construction Standards

The transmission, distribution and substation design and construction standards described in Section 6 are in affect and apply to all new facilities as well as all rebuilds, relocations and maintenance.

A majority of new distribution facilities Tampa Electric constructs each year is placed underground, however the company has averaged 20 miles of new overhead distribution construction over the last few years. The company also has multiple new transmission line construction projects starting within the next three years. There will be approximately 45 miles of 230 kV construction and approximately 36 miles of 69 kV construction occurring by 2010. These transmission projects will add a significant amount of capacity and redundancy to the state transmission grid.

7.2 Maintenance programs

7.2.1 Vegetation Management

Tampa Electric's Transmission and Distribution Vegetation Management Program includes a balanced approach to improve the quality of line clearance while adhering to the American National Standards Institute ("ANSI") A300 pruning standards. The company manages over 6,100 miles of distribution and 1,200 miles of transmission lines over five counties within Florida. The company's vegetation management plan calls for every circuit to be trimmed every three years with a special emphasis on critical trimming based in areas identified by Tampa Electric's reliability base methodology. Established vegetation management program funding levels are estimated at \$9.3 million annually for 2007 through 2009.

7.2.2 Distribution Maintenance

7.2.2.1 Pole Replacements

Tampa Electric's Wood Pole Groundline Inspection Program is part of a comprehensive program initiated by the FPSC for Florida investor-owned electric utilities to harden the electric system against severe weather and unauthorized and unnoticed non-electric pole attachments which affect the loadings on poles.

This inspection program complies with Order No. PSC-06-0144-PAA-EI, issued February 27, 2006 in Docket No. 060078-EI which requires each investor-owned electric utility to implement an inspection program of its wooden transmission and distribution poles on an eight-year cycle based on the requirements of the NESC. This program provides a systematic identification of poles that require repair or replacement to meet strength requirements of NESC.

Pole inspection targets by service area are established with a goal of completing approximately 12.5 percent of the entire system each year. The 2007-2009

groundline pole inspections program goals/targets include approximately 38,000 distribution pole inspections at an estimated annual cost of \$1.5 million.

Tampa Electric will conduct a pole loading analysis and data collection on poles having third party attachments. The analysis will ensure that the condition of the pole meets the requirements in Table 261-1A of the NESC and Tampa Electric Construction Standards.

Tampa Electric sets an aggressive goal to complete all the required replacements prior to hurricane season the year following the inspection. Tampa Electric's Groundline Inspections Program strategy takes a balanced approach and has produced excellent results in a cost effective manner. The future inspections coupled with its pole replacement program will ultimately harden Tampa Electric's transmission and distribution poles.

In 2007, Tampa Electric will replace an estimated 1,420 distribution poles at a total cost of \$3.3 million. The 2007 goals were developed using historical failure rates scaled to the increased inspection cycles.

7.2.3 Transmission Maintenance

The Tampa Electric transmission system inspection program identifies potential system issues along the entire transmission circuit by analyzing the structural conditions at the groundline and above ground as well as the conductor spans. The inspection program is a multi-pronged approach with inspection cycles of one, six or eight years depending on the goals or requirements of the individual inspection activity. Formal inspection activities included in the program are groundline inspection, ground patrol, aerial infrared patrol, above ground inspection and substation inspections. The ground patrol, aerial infrared patrol and substation inspections are performed on one-year cycles, the above ground inspection is performed on a six-year cycle and the groundline inspection is performed on an eight-

year cycle. Additionally, pre-climb inspections are performed prior to commencing work on any structure.

7.2.3.1 Groundline Inspection

Tampa Electric has implemented a groundline inspection program that complies with the Commission's order requiring groundline inspection of wooden transmission structures. In addition, Tampa Electric has included provisions in the groundline inspection program to identify deficiencies with non-wood structures. Groundline inspections are performed on an eight-year cycle. Each year approximately 12.5 percent of all transmission structures are scheduled for inspection. These inspections will also include a wind load analysis that will be performed on the structures where third party attachments are present. In 2007, groundline inspections are planned on 3,412 transmission structures. This represents approximately 12.5 percent of the company's transmission structures. The 2007 estimated cost for this activity is \$135,000 and it is anticipated that the annual number of inspections and budget for 2008 and 2009 will be similar.

7.2.3.2 Ground Patrol

The ground patrol is a visual inspection for deficiencies including poles, insulators, switches, conductors, static wire and grounding provisions, crossarms, guying, hardware and encroachment. The ground patrol will include identification of vegetation encroachment as well as all circuit deficiencies. All transmission circuits are patrolled by ground at least once prior to the beginning of storm season each year. The budget for the ground patrol is estimated to be \$46,000 annually.

7.2.3.3 Aerial Infrared Patrol

The aerial infrared patrol is performed annually on the entire transmission system. It is performed by helicopter with a contractor specializing in thermographic power line inspections and a company employee serving as navigator and observer. This inspection identifies areas of concern that are not readily identifiable by normal visual methods as well as splices and other connections that are heating abnormally and may result in premature failure of the component. This inspection also identifies obvious system deficiencies such as broken crossarms and visibly damaged poles. Since many of these structures are on limited access ROW, this aerial inspection provides a frequent review of the entire transmission system and helps identify potential reliability issues in a timely manner. The infrared patrol is planned for 100 percent of the transmission circuits with an annual budget of \$53,000.

7.2.3.4 Above Ground Inspection

Above ground inspections are performed on transmission structures on a six-year cycle; therefore, each year approximately 17 percent or one-sixth of transmission structures are inspected. This inspection is typically performed by a contractor specializing in above ground power pole inspection and may be performed by climbers, bucket truck or helicopter. The above ground inspection is a comprehensive inspection that includes assessment of poles, insulators, switches, conductors, static wire, grounding provisions, crossarms, guying, hardware and encroachment issues. This program provides a detailed review of the above ground condition of the pole and the associated hardware on the structure. Above ground inspections are planned annually for approximately 17 percent of the company's transmission structures or, 3,784 structures comprising 22 circuits. The annual spending for this activity is estimated at \$200,000.

7.2.3.5 Pre-Climb Inspections

While not a part of the formal inspection program outlined above, Tampa Electric crews are required to inspect poles prior to climbing. As part of these inspections, the employee is required to visually inspect each pole prior to climbing and sound each pole with a hammer if deemed necessary. These pre-climbing inspections serve to provide an additional integrity check of poles prior to the employee ascending the pole and may also result in the identification of any structural deterioration issues.

7.2.3.6 Reporting

Standardized reports are provided for each of the formal inspections. Deficiencies identified during the inspections are entered into a database. This maintenance database is used to prioritize and manage required remediation. Deficiencies identified during the pre-climb inspections are assessed by the on-site crew and reported to supervisory personnel for determination of next steps.

7.2.3.7 Pole Replacements

Tampa Electric is hardening the existing transmission system in a prudent, cost effective manner utilizing its inspection and maintenance program to systematically replace wood structures with non-wood structures. The company has approximately 26,000 transmission poles in service today with wood poles accounting for approximately 17,000 of the total. In 2007, it is estimated that Tampa Electric will harden 623 transmission structures with a budget of \$6.9 million. This includes 421 structure replacements with steel or concrete poles and 202 sets of insulators replaced with polymer insulators. The 2007 hardening goals were developed using historical failure rates scaled to the increased inspection cycles. It is anticipated that 2008 and 2009 will have a similar amounts of replacements and expenditures.

In addition to the pole replacements discussed above, Tampa Electric is aware of approximately 40 transmission line relocation projects within the next three years.

These projects are a combination of road construction and new development. The timing of these projects is primarily based on the governmental agencies' and the developer's schedule. It is estimated that approximately 250 wood poles will be replaced with 250 non-wood poles during the next three years due to these projects at an annual cost of approximately \$1 million.

Community outreach has already begun for most of these projects and will continue until construction is complete. Tampa Electric's community outreach program involves informational mailings to all customers in the vicinity of the project, multiple community meetings, communication to governing agencies, project information on the internet and notifications in local newspapers.

7.2.4 Substation Maintenance

Flood zones are carefully evaluated when building on existing sites or when selecting future sites. Over the next three years, the company will review existing sites in the Flood Zone 1 designated area. The major focus will be on the elevation and water resistance of control cabinets and related equipment. Prudent modifications will be made. Consideration will be given to whether there will be load to be served in the area of the substation immediately after a storm and if any load can be picked up from adjacent substations that are outside the flooded area.

When transformers are added to an existing substation or a transformer is upgraded, existing fences are removed and new fences are installed to current NESC wind and height standards. At the same time, animal protection covers are installed on all 13 kV bushings, lightning arrestors, switches and leads. This will help prevent damage from debris that does get inside the substation. This type of work will be done in about five substations per year based on current expansion plans. These improvements cost an average of \$75,000 per substation and the total estimated cost for 2007 through 2009 is \$1.1 million.

Tampa Electric also plans to convert from fuses or ground switch protection to circuit switchers at four locations per year over the next three years based on current

expansion plans. These improvements cost an average of \$100,000 per location and the total estimated cost for 2007 through 2009 is \$1.2 million.

7.3 Other Storm Hardening Initiatives

7.3.1 Downtown Network

The Tampa downtown network is a small area of dense loads made up mostly of high-rise office buildings. This area is considered critical infrastructure because of the high concentration of business and governmental buildings in this area. The types of businesses include telecommunications switching center, banking, city and county governmental offices, federal and county courthouses as well as approximately 2500 hotel rooms and 6.5 million square foot of office space. The Marion Street substation serves the downtown network with six underground distribution circuits. The boundaries shown in Fig. 5 are as follows: Interstate 275 on the north, Morgan Street to Cass Street to Jefferson Street to Zack Street to Governor Street to Whiting Street on the east; Whiting Street on the south and the Hillsborough River on the west.



Fig. 5 - Downtown Network Boundaries

The downtown network consists of 361 manholes and 56 network vaults. Most contain two network transformers and two network protectors. The typical elevation in the downtown area is twelve feet or greater, however, there are a few areas with lower elevation. These areas are west of Ashley Street and south of the Crosstown Expressway. In these areas, there are eight below grade vaults and two additional vaults that have historical flooding tendencies. Although network protectors are thought to be waterproof, Tampa Electric has put into its storm hardening plans the pressure testing of the 18 network protectors located in the 10 low lying manholes and vaults. If the results of the tests show any signs of leakage, all the pertinent gaskets will be replaced. The total three-year costs for this project are estimated to be \$60,000.

7.3.2 Tampa International Airport

Tampa International Airport is served by six distribution circuits which are all underground and emanate from one substation. Tampa Electric's plan is to upgrade a transmission segment feeding the Skyway substation to today's extreme wind construction standards. The project consists of replacing 62 existing wood transmission poles with steel or concrete poles. While Skyway substation has multiple transmission feeds, this project will ensure that one of them is upgraded to non-wood structures that meet today's construction standards. The project will be completed in 2009 at an estimated cost of \$618,000.

7.3.3 Conversion of remaining 4 kV distribution circuits

Tampa Electric is proposing to convert the remaining three 4 kV distribution circuits as part of its hardening plans. The benefits are in the form of standardizing the distribution voltage to only 13.2 kV. This will eliminate the confusion of dual distribution voltages and the need to have different construction standards and critical spare material, which will result in faster restoration. The plan is to complete the engineering in 2007 and construction in 2008 at an estimated cost of \$582,000.

7.3.4 Overhead to Underground Conversion of Interstate Highway Crossings

This activity focuses on hardening limited access highway crossings which will prevent the hindrance of first responders, emergency vehicles and others due to fallen distribution lines blocking traffic. The restoration of downed overhead power lines over interstate highways can be lengthy because of heavy traffic congestion. Tampa Electric's current preferred construction standard requires all distribution line interstate crossings to be underground. Therefore, the company's hardening plan calls for converting several overhead distribution line crossings on interstates I-75, I-4

and the East-West section of I-275 to underground. The three year plan is to underground 12 distribution line crossings at a total estimated cost of \$600,000 or four crossings at an annual cost of \$200,000.

7.3.5 Post-Storm Data Collection and Forensic Analysis

As outlined in Tampa Electric's 2006 Storm Implementation Plan filed March 2, 2007, Tampa Electric plans to implement a formal process to randomly sample system damage following a major weather event in a statistically significant manner. This information will be used to perform forensic analysis in an attempt to categorize the root cause of equipment failure. From these reports, recommendations and possible changes will be made regarding engineering, equipment and construction standards and specifications. Data Collection Operations personnel will patrol a representative sample of the damaged areas of the electric system following a major storm event and perform the data collection process. At a minimum, the following types of information will be collected:

- Pole/Structure - type of damage, size and type of pole, and likely cause of damage.
- Conductor - type of damage, conductor type and size, and likely cause of damage.
- Equipment - type of damage, overhead or underground, size, and likely cause of damage.
- Hardware - type of damage, size and likely cause of damage.

Engineering personnel will perform the forensic analysis of a representative sample of the data obtained to evaluate the root cause of failure and assess future preventive measures where possible and practical. This will include evaluating the type of material used, the type of construction and the environment where the damage

occurred including existing vegetation and elevations. Changes will be recommended and implemented, if more effective solutions are identified by the analysis team.

7.4 Extreme Wind Pilot Program

Tampa Electric's three-year strategy for piloting the extreme wind loading criteria on distribution facilities focuses on targeting two critical customers. These include a local hospital and the Port of Tampa gasoline tank storage area. The circuits feeding the hospital and the Port of Tampa will be rebuilt to meet extreme wind loading and their performance will closely be monitored during and after hurricane events and compared to the performance of other circuits in the same area built to the current standard.

7.4.1 Port of Tampa

The Port of Tampa is a critical facility as it serves 10 petroleum distribution customers that deliver 40 percent of the gasoline in the state of Florida. Six miles of distribution feeder will be rebuilt to meet the extreme wind requirements as shown in Fig. 6.



Fig. 6 – Aerial photograph of Port of Tampa with outlined distribution route

The three-year deployment strategy for this extreme wind upgrade project is as follows:

2007 – Rebuild a three-mile feeder to the north of the Maritime substation. This will include upgrading approximately 111 distribution poles and replacing 38 wood transmission poles with non-wood poles at an estimated cost of \$760,000.

2008 - Rebuild the one-mile feeder to the south of the Maritime substation. This will include upgrading approximately 37 distribution poles estimated cost \$120,000.

2009 – Rebuild a two-mile feeder from an alternative substation to pick up three miles of a previously rebuilt (from 2007 and 2008) feeder should a flooding event at the Maritime substation site occur. This will include upgrading approximately 74 distribution poles at an estimated cost of \$240,000. As a side benefit, the Hillsborough County Sheriffs Operation Center will also be served from the hardened feeder.

7.4.2 Saint Joseph's Hospital

While there are several hospitals in Tampa Electric's service territory that are considered critical customers, Saint Joseph's Hospital was chosen for this pilot program because of its Level 2 Trauma Center status, central location, high elevation and the cost effectiveness of the hardening activities. The distribution feeder serving the hospital is approximately one-mile in length and will be rebuilt to meet the extreme wind requirements. The hardening measures to be employed include replacing 37 distribution poles and with a stronger class wood poles estimated cost of \$120,000 and six wood transmission poles with non-wood pole at an estimated cost of \$70,000. This project location is shown in Fig. 7 and is planned for 2008.



Fig. 7 – Aerial photograph of Saint Joseph's Hospital with outlined distribution route

7.5 2007-2009 Deployment and Costs

The storm hardening projects planned by Tampa Electric through 2009 with their estimated costs are summarized below in Table 3.

Project	2007	2008	2009
Port of Tampa	\$760,000	\$120,000	\$240,000
Saint Joseph's Hospital	0	190,000	0
Tampa International Airport	0	0	618,000
Downtown Tampa Network	20,000	20,000	20,000
Conversion of 4 kV Circuits	42,000	480,000	0
Hardening of Interstate Crossings	200,000	200,000	200,000
Transmission pole inspections	135,000	147,000	152,000
Transmission above ground inspections	182,000	211,000	217,000
Transmission pole replacements	6,854,000	7,010,000	7,220,000
Distribution pole inspections	1,627,000	2,074,000	2,136,000
Distribution pole replacements	3,300,000	5,750,000	6,040,000
Pole reinforcements	1,004,000	894,000	920,000
Substation enhancements	775,000	775,000	775,000
Vegetation management	9,300,000	9,600,000	9,900,000
Total	\$24,199,000	\$27,471,000	\$28,438,000

Table 3. Estimated 2007-2009 Storm Hardening Costs

7.5.1 Third Party Attacher Benefits and Impacts

Tampa Electric's 2007 – 2009 Storm Hardening Plan is expected to provide benefit to all third party attachers and have minimal impact on third parties attached to our system. The facilities that are planned to be rebuilt to extreme wind loading criteria will utilize the same route and require that the attachers merely transfer from the old

poles to the new poles. The largest impacts will come from the increased pole inspections, which now include a pole loading analysis and the annual pole attachment audit that Tampa Electric will perform.

Pole loading calculations will be conducted as part of the pole inspection program on any joint use pole to ensure that each pole is not overloaded or approaching overloading. Any pole that fails a preliminary stress test will be flagged and a comprehensive pole loading analysis will be conducted to determine if the pole is overloaded and, if it is, which attachment is actually causing the overload. If the responsible party is a joint use attaching entity that has not permitted with Tampa Electric to be on that pole, Tampa Electric will notify the joint use entity which will have the choice of removing their attachment(s) or paying for the cost of any needed corrective action. Comprehensive loading analysis results will indicate the percent of utilization by each attaching entity. If it is determined that a Tampa Electric attachment caused the pole to be overloaded, the pole will be replaced and the attaching entities will be notified of the need to transfer their attachments to the new pole. If it is determined that an attaching entity overloaded the pole, Tampa Electric will work with attaching entities to determine when an attachment was placed and whether the attachment was approved by Tampa Electric prior to being placed on the pole. Once it is determined which entity overloaded the pole, that entity will be responsible for any corrective measures required to mitigate the overload. Each situation will be evaluated on a case by case basis with consideration given to the circumstances of the particular pole being evaluated.

Tampa Electric will also conduct an audit of all pole attachments on an eight-year cycle at a minimum. The purpose of this attachment audit is to identify the location of each pole; the facilities attached and to obtain verification that such attachments are pursuant to a current joint use agreement. Costs of this audit will be shared by all attaching entities. Following the audit, if any unauthorized attachments are found, Tampa Electric will true-up its pole attachment count and back bill to the last audit unless attacher can provide documentation of an approved permit authorizing the attachment. Unauthorized attachment fees may also be assessed for any attachments

not previously approved. Additionally, the attacher will be responsible to pay for a complete engineering study and for any corrective action required to meet NESC and/or Tampa Electric construction standard requirements.

8 ATTACHMENT STANDARDS AND PROCEDURES

Tampa Electric has approximately 330,000 third party attachments on its transmission and distribution poles throughout its service territory. This includes attachments made by telecommunications companies, cable TV companies and governmental entities. This section of the plan outlines the standards, procedures and policies that must be adhered to by all third party attaching entities.

8.1 Access to Tampa Electric poles

Access to Tampa Electric poles is granted only to those companies who have an attachment agreement with the company. Licensee must also secure any necessary permit, consent, or certification from state, county or municipal authorities or private property owners prior to attaching. If an attaching entity does not currently have an agreement with Tampa Electric, it is necessary to contact the Pole Attachment and Contract Administration Department at the company (see Attachment B).

8.2 Permit Application Procedure

Prior to permit application submittal; the licensee should take the time to review it's attachment agreement with Tampa Electric, including the Tampa Electric construction standards as outlined in Section 6.

Prior to attaching, a completed permit application (see Attachment C) shall be submitted to Tampa Electric for all new attachment requests or overlashing to

existing attachments requests on Tampa Electric owned distribution and transmission poles.

No access will be granted for attachment to any poles that are specifically used for private and street lighting systems only. Access to transmission poles is not mandated by the Telecommunications Act of 1996 and is typically not granted due to excessive make ready construction costs. It is recommended that the licensee should avoid permitting to attach to transmission poles whenever possible. A complete engineering study for transmission facilities may take much longer than the 45 days it takes for distribution pole access.

8.2.1 Permit Application Documentation

Licensee's completed permit application shall also include the documentation listed below. Additionally, a deposit may be required for the engineering study and any make ready construction activities. Omission of any required documentation may result in the rejection of licensee's permit application delaying the permit approval.

- Attachment C must be completed in its entirety
- Legible map showing entire route highlighted, along with identification to correlate poles on map to poles identified in Attachment C
- Overall county or city site map highlighted and identifying the proposed construction area
- Required documents must be submitted in duplicate
- Deposit fee in the amount of \$200.00 per pole (This may be based on credit worthiness and/or contract terms and conditions.)

8.2.2 Permit Engineering Study Review

Once Tampa Electric has received and accepted licensee's completed permit application, the company will review the proposed pole attachments and conduct a complete engineering study to ensure compliance of the NESC and Tampa Electric's construction standards. This study will include a structural loading and a clearance analysis on each pole. This study may take up to 45 days to complete for distribution poles and typically longer for transmission poles. Therefore, permit applications should be submitted a minimum of 90 days in advance of the expected installation date and an additional 45 days for make ready construction involving transmission. For joint use parties (e.g., Verizon, Embarq), Tampa Electric will determine whether joint use is excluded on any pole application within 10 days.

8.3 Make Ready

8.3.1 Make Ready Construction Not Required

If the results of the engineering study find no existing or proposed violations with the NESC and Tampa Electric construction standards, the company will return a signed copy of licensee's permit request (see Attachment C) approving the installation of the proposed attachments. The licensee has 120 days from the approved permit date to complete attachment construction.

8.3.2 Make Ready Construction Required by Tampa Electric

If it is determined that make ready construction by Tampa Electric is necessary to accommodate the proposed attachments, the company will notify licensee in writing of the required work along with an estimate of the construction costs. Upon licensee's acceptance of the estimate and submittal of any additional payments over and beyond the initial deposit, Tampa Electric will schedule and complete the required make ready work. Upon completion of the make ready construction, Tampa Electric will

return a signed copy of licensee's permit request (see Attachment C) approving the installation of the proposed attachments. The licensee has 120 days from the approved permit date to complete attachment construction.

8.3.3 Make Ready Construction Required by Existing Third Party Attacher

If it is determined that make ready construction by a third party attacher is necessary (lower or raise attachments) to accommodate the proposed attachments, Tampa Electric will notify licensee via the National Joint Utilities Notification System ("NJUNS") describing the re-arrangement work required. The NJUNS system is internet based and is located at www.njuns.com. This system is used by Tampa Electric to communicate with its pole attachment licensees of the need to perform work. The licensee must contact the responsible third party directly to negotiate work schedules and/or costs. Upon completion of this work, Tampa Electric shall be notified via the completion of the NJUNS ticket which will prompt the company to schedule an inspection to confirm all make ready construction has been completed. Once approved, Tampa Electric will return a signed copy of Licensee's permit request (see Attachment C) approving the installation of the proposed attachments. The licensee has 120 days from the approved permit date to complete attachment construction.

8.4 Tampa Electric Post Inspection Process

Upon completion of licensee's attachment installation, licensee shall forward a completed copy of the Attachment D identifying the poles attached to with either the 10 digit geographic location number ("GLN") which is typically white numbers on a green background secured to the pole, or if no GLN exists, the six digit asset tag number located on a silver tag secured to the pole as well as the date attached and return to Tampa Electric. The company will perform a post inspection of licensee's

construction. If Tampa Electric finds licensee's construction to meet all NESC and Tampa Electric standards, the company will authorize the installation, close the job and reconcile the final costs.

8.4.1 Code Violations

If the company finds any violations of Tampa Electric construction standards, licensee will be notified via NJUNS to make immediate corrections. The licensee will be given 30 days to correct the violations before Tampa Electric will schedule a second post inspection. If licensee fails the second post inspection, Tampa Electric will complete the work for licensee at licensee's expense. Repeated failure to correct any code violations within the 30 day time period may result in suspension of future attachment rights.

8.5 National Joint Utility Notification System

NJUNS (www.njuns.com) is an electronic notification tool used to notify licensee of any code violations found during the post inspection process. The use of this tool is paid for by Tampa Electric and does not cost licensee anything to use. The licensee will be required to communicate with Tampa Electric via this tool regarding all permit applications per its attachment agreement. Prior to submitting any permit application, licensee must have created an NJUNS account. Additionally, as part of its normal construction process, Tampa Electric will use NJUNS to notify licensees of the need to perform cable or equipment transfers when poles are being replaced or are being relocated. The licensee should contact Tampa Electric for assistance if necessary.

8.6 Permit Closeout and Final Billing

Upon completion of licensee's permit application, Tampa Electric will complete the final billing within 60 days of the completion date. Tampa Electric will reconcile the estimated pre-paid costs and the actual incurred costs. Tampa Electric will issue a refund check for any over payments or an invoice for any additional monies owed to the company. The invoice will include the total costs of the engineering conducted to process licensee's permit application and any construction costs due to make ready. If licensee's permit resulted in new attachments to Tampa Electric poles, licensee will also receive an invoice for the advanced pole rental due for the total of the new pole attachments.

8.7 Pole Inspection Program

Pursuant to FPSC Order No. PSC-06-0144-PAA-EI (eight-year pole inspection requirement), Tampa Electric will conduct an inspection of all poles on its system on an eight-year cycle for distribution poles and a six-year cycle for transmission poles to evaluate the condition of each pole. Additionally, stress calculations will be conducted on any joint use pole to ensure that each pole is not overloaded or approaching overloading for instances not already addressed by Order No. PSC-06-0144-PAA-EI. Any pole that fails a preliminary stress test will be flagged and a comprehensive pole loading analysis will be conducted to determine two things: 1) confirm if the pole is in fact overloaded and 2) if overloaded, which attachment is actually causing the overload. If the responsible party is a joint use attaching entity that has not permitted with Tampa Electric to be on that pole, Tampa Electric will notify said party. The joint use entity will have the choice to remove their attachment(s) or pay for the cost of corrective action. Corrective action will typically require either a pole replacement or the installation of an Osmose extended steel truss (E-truss).

8.8 Joint Use Pole Attachment Audit

Pursuant to FPSC Order No. PSC-06-0351-PAA-EI, Tampa Electric will conduct an audit of all pole attachments on an eight-year cycle at a minimum. For some licensees, Tampa Electric reserves the right to complete this audit annually. The decision to perform an audit on an annual basis will be made by Tampa Electric based on need and cost effectiveness. The purpose of this audit of joint use attachments is to identify the location of each pole and the facilities attached and verification that such attachments are pursuant to a current joint use agreement. The cost of this audit is shared amongst all attaching entities. Tampa Electric tags and identifies all pole locations using a geographical positioning system. If any unauthorized attachments are found, Tampa Electric reserves the right to true-up its pole attachment count and back bill to the last audit unless licensee can provide documentation of an approved permit authorizing the attachment (see Attachment C). Unauthorized attachment fees will also be assessed for any attachments not previously approved. Additionally, licensee will be responsible to pay for a complete engineering study and for any corrective action required to meet Tampa Electric construction standards.

Attachment A

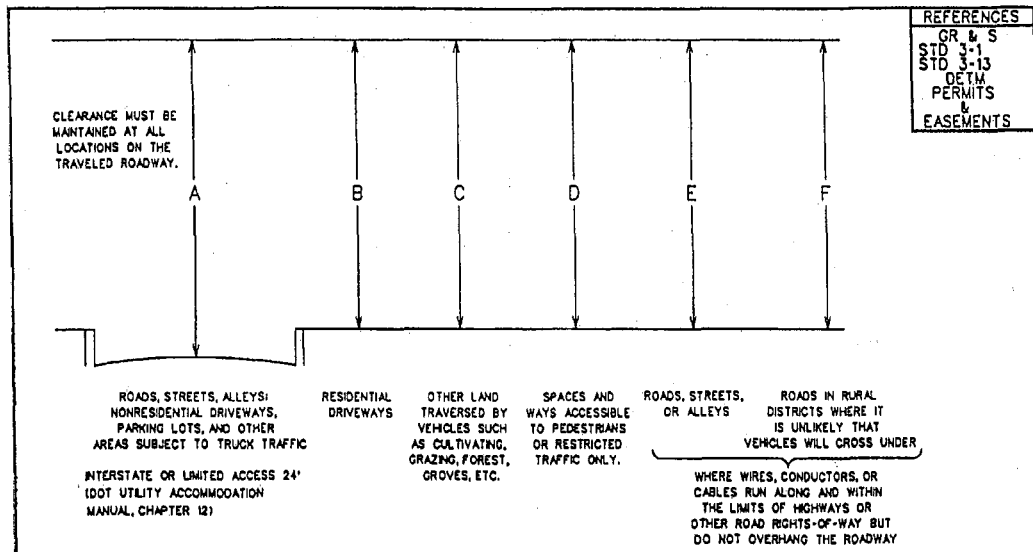

REFERENCES
CR & S STD 3-1 STD 3-13 DETM. PERMITS & EASEMENTS

(VOLTAGES ARE PHASE-TO-GROUND FOR EFFECTIVELY GROUNDED CIRCUITS AND THOSE OTHER CIRCUITS WHERE ALL GROUND FAULTS ARE CLEARED BY PROMPTLY DE-ENERGIZING THE FAULTED SECTION, BOTH INITIALLY AND FOLLOWING SUBSEQUENT BREAKER OPERATIONS.)

CLEARANCE CODE (SEE ABOVE ILLUSTRATION.)	INSULATED COMMUNICATION CONDUCTORS AND CABLE MESSAGERS; SURGE-PROTECTION WIRES; GROUNDED GUYS; UNGROUNDED GUYS EXPOSED TO 0 TO 300V NEUTRAL CONDUCTORS MEETING RULE 230C4; SUPPLY CABLES MEETING RULE 230C1	NONINSULATED COMMUNICATION CONDUCTORS; SUPPLY CABLES OF 0 TO 750 V MEETING RULES 230C2 OR 230C3	SUPPLY CABLES OVER 750 V MEETING RULES 230C2 OR 230C3; OPEN SUPPLY CONDUCTORS, 0 TO 750 V UNGROUNDED GUYS EXPOSED TO OVER 300 V TO 750 V	OPEN SUPPLY CONDUCTORS, OVER 750 V TO 22KV; UNGROUNDED GUYS EXPOSED TO 750 V TO 22KV	OPEN SUPPLY CONDUCTORS ABOVE 22KV (SEE NOTE 2)
	(FT)	(FT)	(FT)	(FT)	
A	18.0	18.0	18.0	18.5	SEE NOTE 2
B	15.5	16.0 ①	16.5 ①	18.5	
C	15.5	16.0 ②	16.5	18.5 ③	
D	9.5	12.0 ①	12.5 ①	14.5	
E	15.5	16.0	16.5	18.5	
F	13.5	14.0	14.5	16.5	

* THE CLEARANCES REQUIRED BY THE UTILITY ACCOMMODATION GUIDE (DEPARTMENT OF TRANSPORTATION), CITY, COUNTY OR MUNICIPAL AUTHORITY SHALL GOVERN WHERE MORE CONSERVATIVE.

NOTES:

① WHERE THE HEIGHT OF A BUILDING OR OTHER INSTALLATION DOES NOT PERMIT SERVICE DROPS TO MEET THESE VALUES, THE CLEARANCES MAY BE REDUCED TO THE FOLLOWING (REF. 2002 NESC, TABLE 232-1, NOTE 7&8):

	B	D
INSULATED SERVICE DROPS 300V OR LESS TO GROUND	12.5	10.5
INSULATED DRIP LOOPS OF SERVICE DROPS 300V TO GROUND	10.5	10.5
SERVICE DROPS LESS THAN 150V TO GROUND	12.0	10.0
INSULATED DRIP LOOPS OF SERVICE DROPS 150V TO GROUND	10.0	10.0
INSULATED COMMUNICATION SERVICE DROPS	11.5	—

COLUMN "B" APPLIES TO RESIDENTIAL DRIVEWAYS AND COLUMN "D" APPLIES TO SPACES ACCESSIBLE TO PEDESTRIAN TRAFFIC ONLY.

2. THE TRANSMISSION ENGINEERING DEPARTMENT SHOULD BE CONSULTED FOR CLEARANCE CONSIDERATIONS INVOLVING VOLTAGES EXCEEDING 22KV TO GROUND

③ SEE SPEC. 3-13 FOR CLEARANCE REQUIREMENTS IN GROVES.

REF. 2002 NESC 232

3			
2			
1	REM	8-18-05	REVISED NOTE 1
NO.	CK'D	DATE	REVISION

◀ DENOTES LATEST REVISION

D.R. SUPR. APPR. DATE SUPERSEDES	<i>Bob Shinsky</i> 8-18-05 3-4/5-16-02	<h2 style="margin: 0;">VERTICAL CLEARANCE OVER AND ADJACENT TO ROADS, DRIVEWAYS AND OTHER LAND AREAS</h2>
3-4	TAMPA ELECTRIC CO. STANDARDS GENERAL RULES & SPECIFICATIONS	

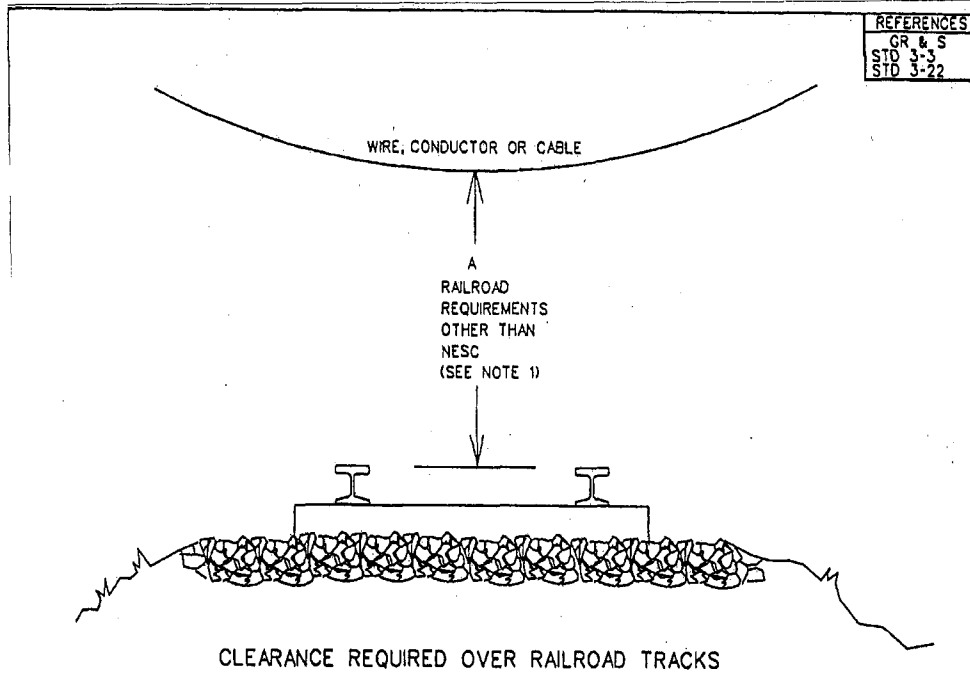

REFERENCES	
GR & S	
STD 3-3	
STD 3-22	

(VOLTAGES ARE PHASE-TO-GROUND FOR EFFECTIVELY GROUNDED CIRCUITS AND THOSE OTHER CIRCUITS WHERE ALL GROUND FAULTS ARE CLEARED BY PROMPTLY DE-ENERGIZING THE FAULTED SECTION, BOTH INITIALLY AND FOLLOWING SUBSEQUENT BREAKER OPERATIONS.)

CLEARANCE CODE (SEE ABOVE ILLUSTRATION.)	INSULATED COMMUNICATION CONDUCTORS; SURGE PROTECTION WIRES; GROUNDED GUYS; MESSENGERS; EFFECTIVELY GROUNDED NEUTRALS ASSOCIATED WITH CIRCUITS OF LESS THAN 22kV TO GROUND.	OPEN SUPPLY CONDUCTORS 0 TO 750V	NON-INSULATED COMMUNICATION CONDUCTORS; INSULATED CABLED SUPPLY CONDUCTORS OF 0 TO 750V WHEN SUPPORTED BY AN EFFECTIVELY GROUNDED BARE MESSENGER	PRIMARY CONDUCTORS OF 750V TO 15kV TO GROUND. (CIRCUIT MUST BE EFFECTIVELY GROUNDED)	OPEN SUPPLY CONDUCTORS ABOVE 15kV
	(FT)	(FT)	(FT)	(FT)	
A	28.0	28.0	28.0	28.0	SEE NOTE 2

NOTES:

- CROSSING REQUIREMENTS OF RAILROADS IN OUR SERVICE AREA ARE IN EXCESS OF AND SHALL TAKE PRECEDENT OVER NESC CODE REQUIREMENTS. CROSSING PERMITS AND APPROVAL MUST BE OBTAINED FROM THE RAILROAD INVOLVED. CONTACT PERMITS SECTION. SEE STANDARD 3-3.
- THE TRANSMISSION ENGINEERING DEPARTMENT SHOULD BE CONSULTED FOR CLEARANCE CONSIDERATIONS INVOLVING VOLTAGES EXCEEDING 15kV TO GROUND.

➤ REF. CSX TRANSPORTATION INC.,
 DESIGN & CONSTRUCTION STANDARD SPECIFICATION,
 PLATE V, REVISED 9-15-03

NO.	CK'D	DATE	REVISION
3			
2			
1	REM	8-18-05	REVISED CSX REFERENCE DOCUMENT

◀ DENOTES LATEST REVISION

VERTICAL CLEARANCE OVER RAILROADS

D.E. SUPR. *Bob Shulz*
 APPR. DATE 8-18-05
 SUPERSEDED 3-5/5-16-02

TAMPA ELECTRIC CO. STANDARDS GENERAL RULES & SPECIFICATIONS

3-5

NOTES:

1. CABLE CLEARANCE MEASUREMENTS SHALL BE TAKEN FROM THE HIGHEST COMMUNICATION CABLE TO THE LOWEST CABLE/CONDUCTOR IN THE SUPPLY SPACE. GROUND CLEARANCE MEASUREMENTS SHALL BE TAKEN FROM THE LOWEST CABLE TO GROUND.
2. THE CATV CABLE ELEVATION MAY BE LOWER WHEN APPROVED BY THE TELEPHONE COMPANY.
3. ELEVATIONS MAY BE LOWERED IF CODE CLEARANCE PERMITS AND UPON THE MUTUAL AGREEMENT OF ALL CABLE OWNERS.
4. ALL COMMUNICATION VERTICAL RUNS OF ALL TYPES SHALL BE PROTECTED AS PER NESC.
5. REFER TO 2002 NESC 235 C (2) (b) (1) (a) FOR SAG RELATED CLEARANCES.
6. IF TEC COMMUNICATION CABLE IS NOT PRESENT, THE 40" DIMENSION IS ALLOWED.
7. ALL CATV EQUIPMENT (SUCH AS AMPLIFIERS, SERVICE DROPS, ETC.) SHALL BE PLACED NO LESS THAN 2'-0" FROM OUTER EDGE OF POLE.
8. ALL GROUNDING AND OVERCURRENT PROTECTION SHALL BE PER APPLICABLE CODES.
9. TEC COMMUNICATIONS CABLE, CATV CABLE, TEL CABLE, AND TRAFFIC CONTROL CABLE, SHALL BE MOUNTED ON THE SAME SIDE OF POLE AS TEC SECONDARY.
10. WHEN THE CONDUCTOR DIRECTLY ABOVE A COMMUNICATION WIRE IN THE SUPPLY SPACE IS A NEUTRAL (NEUTRAL ONLY), THEN THE CLEARANCE MAY BE REDUCED WITH APPROVAL FROM DISTRIBUTION SERVICES. THE COMMUNICATION CABLE SHALL BE SUPPORTED BY AN EFFECTIVELY GROUNDED MESSENGER OR BE AN ENTIRELY DIELECTRIC FIBER OPTIC CABLE.

REFERENCES
 GR&S
 SEC. 8

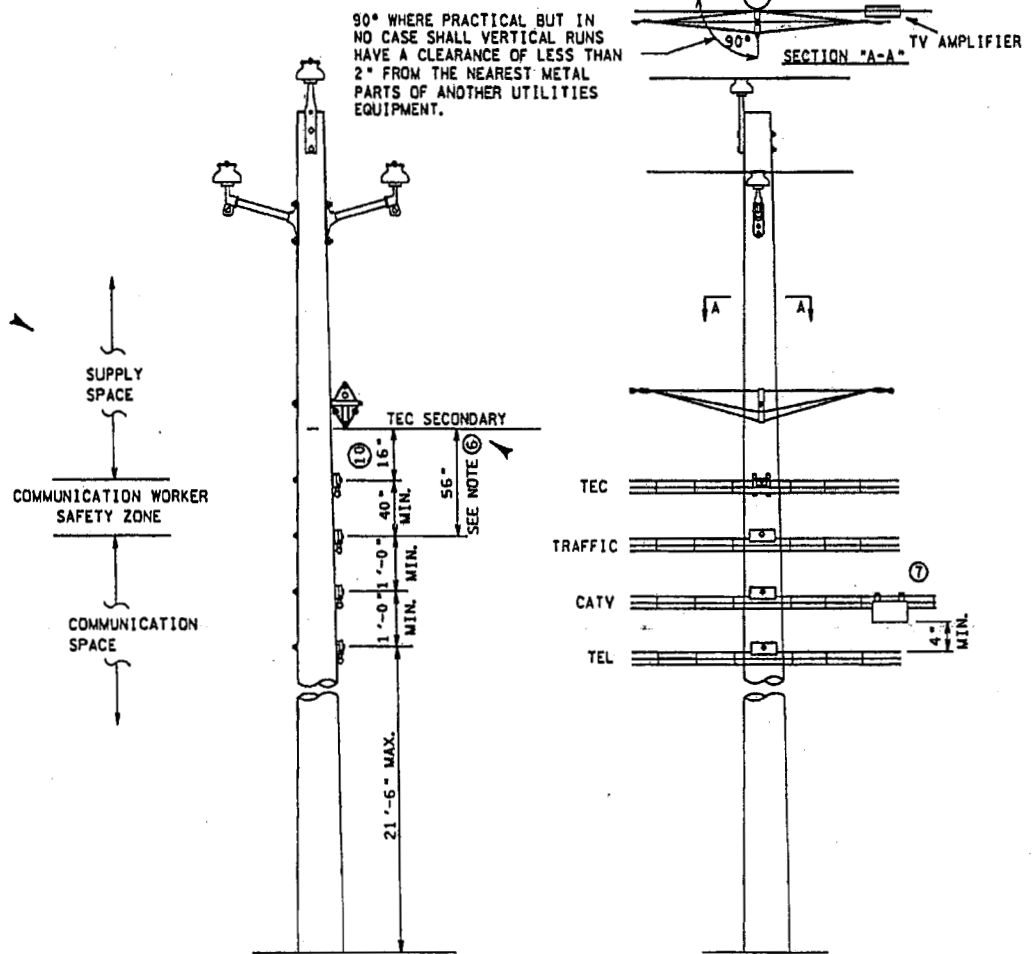

REF. 2002 NESC 235
 ▲ DENOTES LATEST REVISION

NO.	CK'D	DATE	REVISION
3	REM	10-20-05	REVISED TO MEET 2002 NESC
2	REM	8-18-05	ADDED SPACE DISCRPTIONS
1	REM	8-18-05	REVISED NOTES 1, 4, 5, 6, & 7

CLEARANCE FOR JOINT CONSTRUCTION

D.S. SUPR. *Bob Shick*
 APPR. DATE 10-20-05
 SUPERSEDES 3-31/8-18-05

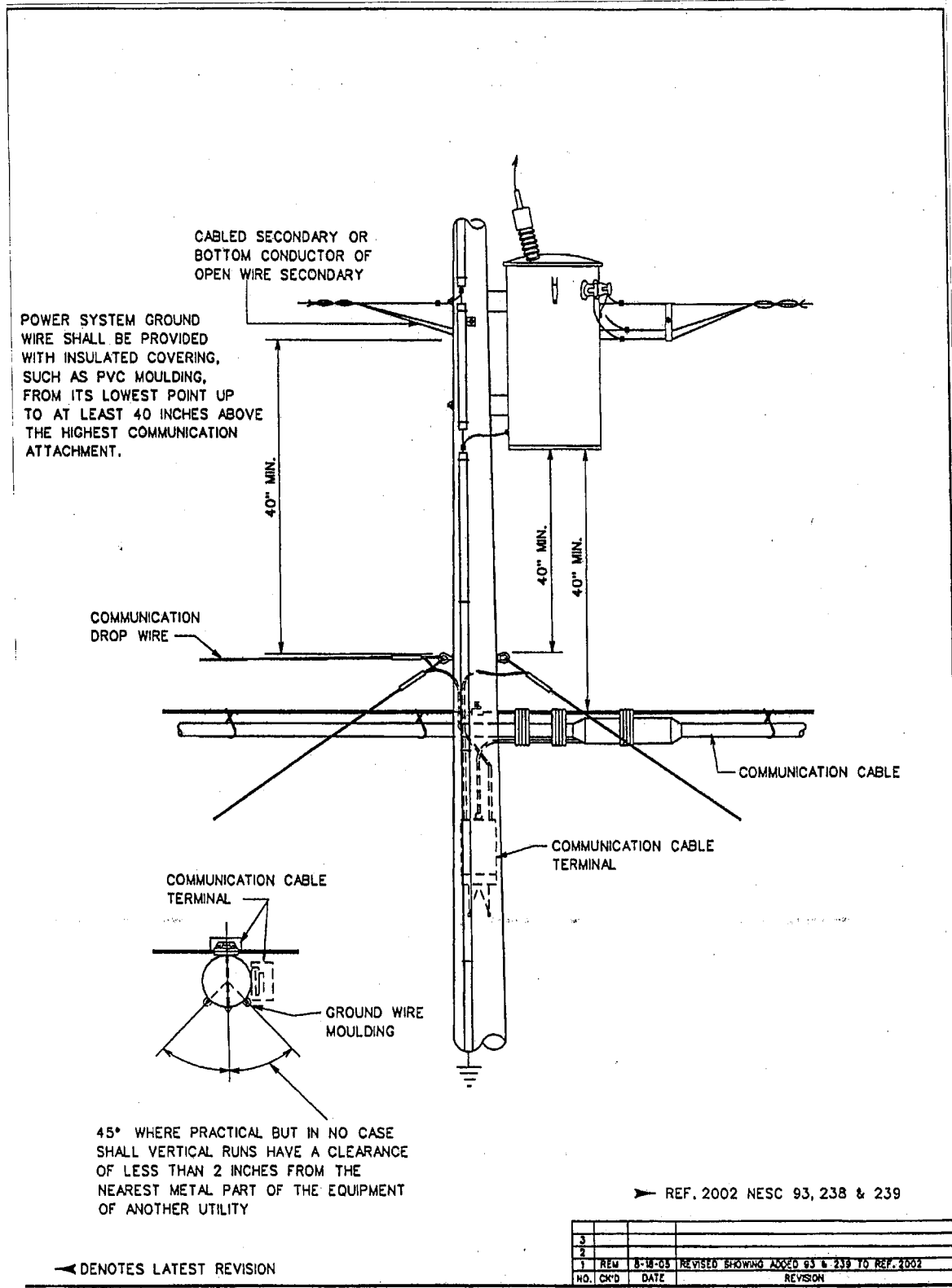

D.S. SUPR. <i>Bob Schuchling</i> APPR. DATE 8-18-05 SUPERSEDES 3-32/5-16-02	CLEARANCE FOR JOINT CONSTRUCTION TRANSFORMER POLE
3-32	TAMPA ELECTRIC CO. STANDARDS GENERAL RULES & SPECIFICATIONS

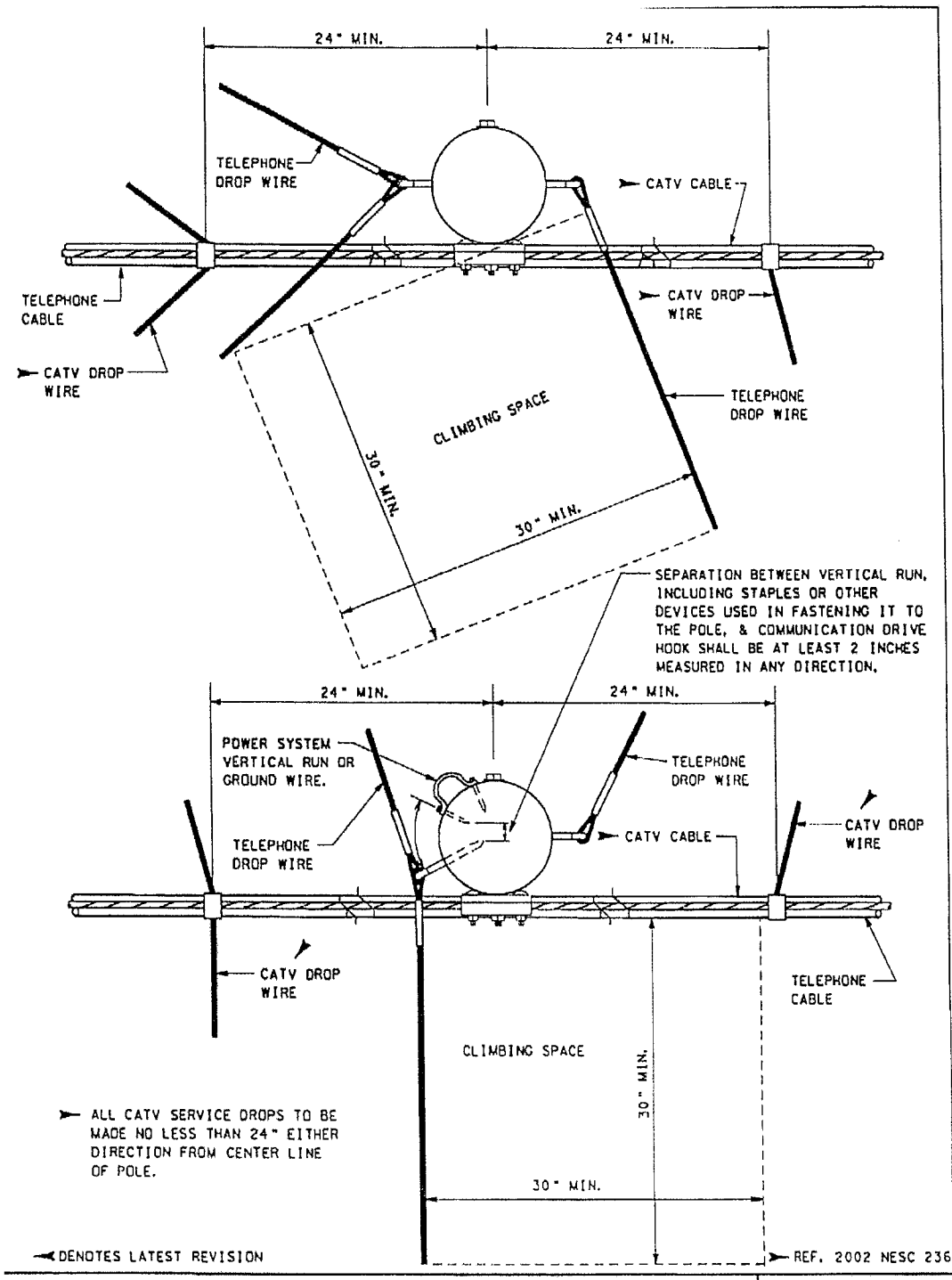

CLIMBING SPACE

➤ THROUGH TELEPHONE AND CATV WIRES

WCA: STD'S *Ken Mathewson*
 APPR. DATE 5-16-07
 SUPERSEDES 3-33/1-16-97

TAMPA ELECTRIC CO. STANDARDS GENERAL RULES & SPECIFICATIONS

3-33

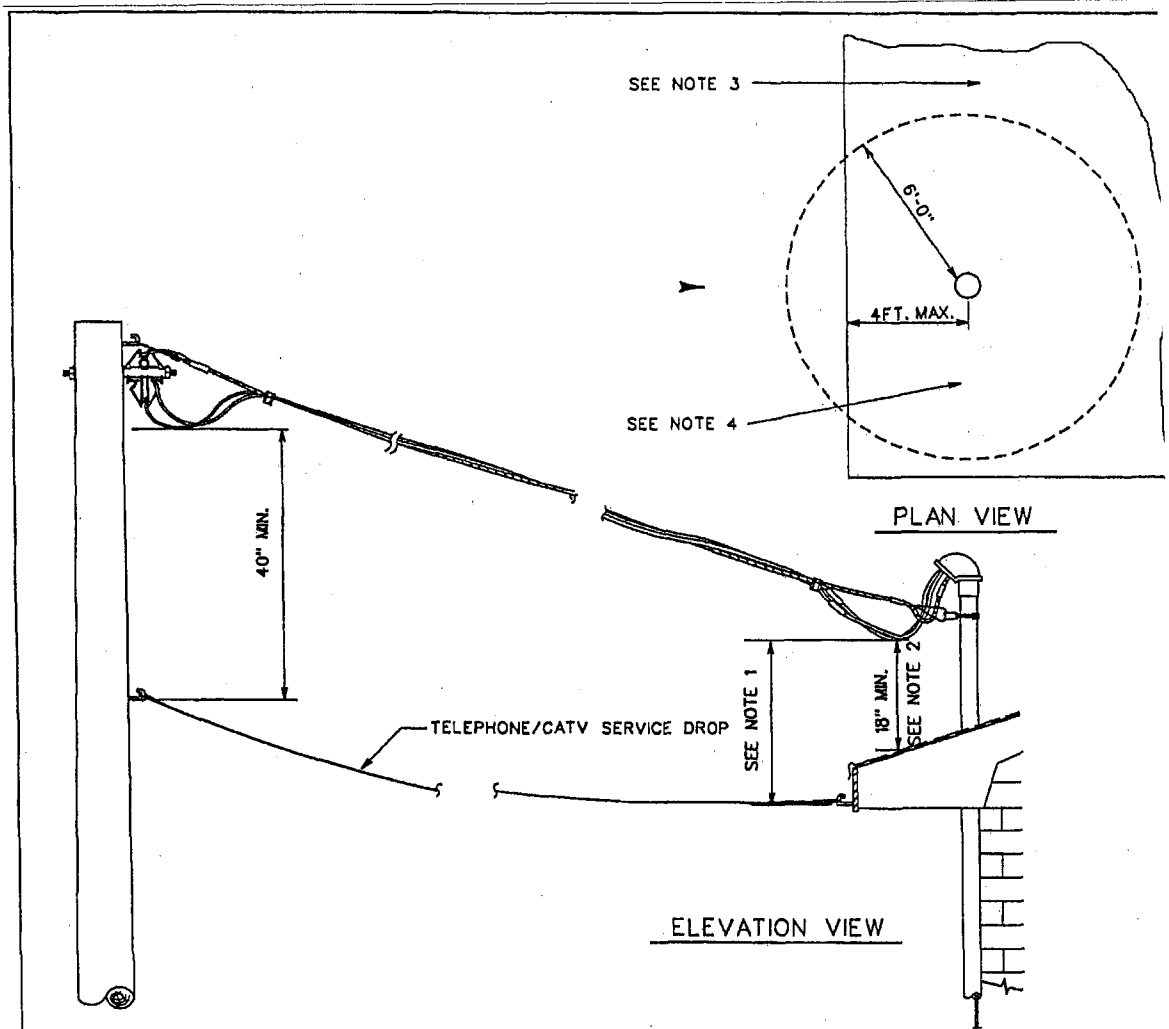

NOTES:

- 1. SUPPLY SERVICE DROPS OF 0 TO 750 VOLTS, RUNNING ABOVE AND PARALLEL TO COMMUNICATION SERVICE DROPS, MAY HAVE A CLEARANCE OF NOT LESS THAN 12 IN. AT ANY POINT IN THE SPAN. THIS INCLUDES THE POINT OF ATTACHMENT TO THE BUILDING OR STRUCTURE BEING SERVED, PROVIDED THAT THE NONGROUNDED CONDUCTORS ARE INSULATED AND THAT THE CLEARANCE, AS OTHERWISE REQUIRED BY RULE 235C1 (2002 NESC), IS MAINTAINED BETWEEN THE TWO SERVICE DROPS AT THE POLE.
- 2. REF. 2002 NESC FIG. 234-2
- 3. MAINTAIN NOT LESS THAN 3'-0" VERTICAL CLEARANCE ABOVE ROOF OUTSIDE 6'-0" RADIUS FROM THE SERVICE MAST.
- 4. MAINTAIN NOT LESS THAN 18" VERTICAL CLEARANCE ABOVE ROOF WITHIN 6'-0" RADIUS FROM THE SERVICE MAST.

◀ DENOTES LATEST REVISION

3			
2			
1	REV	8-18-05	ADDED PLAN VIEW & NOTES 3 & 4, REV. NOTE 1
	NO. CK'D	DATE	REVISION

D.S. SUPPL. *Bob Shindler*
 APPR. DATE 8-18-05
 SUPERSEDES 3-34/5-16-02

CLEARANCES FOR JOINT CONSTRUCTION SERVICES

3-34	TAMPA ELECTRIC CO.	STANDARDS	GENERAL RULES & SPECIFICATIONS
------	--------------------	-----------	--------------------------------

NOTES:

- 1. CABLE CLEARANCE MEASUREMENTS SHALL BE TAKEN FROM THE HIGHEST COMMUNICATION CABLE TO THE LOWEST CABLE/CONDUCTOR IN THE SUPPLY SPACE. GROUND CLEARANCE MEASUREMENTS SHALL BE TAKEN FROM THE LOWEST CABLE TO GROUND.

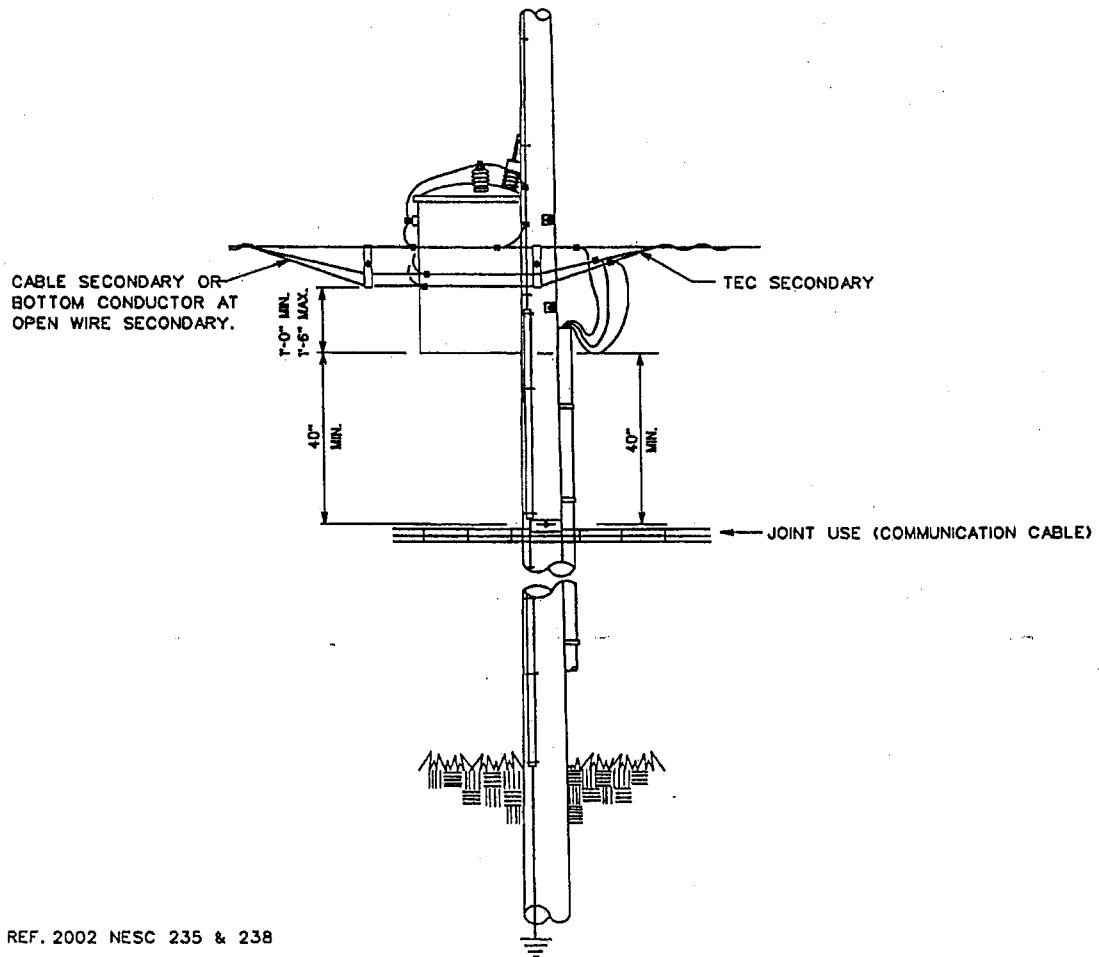

REF. 2002 NESC 235 & 238

◀ DENOTES LATEST REVISION

NO.	CK'D	DATE	REVISION
3			
2	REM	8-18-05	REVISED NOTE 1
1	SAW	7-22-04	REMOVAL UNDERGROUND CONDUIT, TITLE BLOCK

CLEARANCE FROM SERVICE RISER TO JOINT USE ATTACHMENT

D.R. SUPP. *Bob Shindler*
 APPR. DATE: 8-18-05
 SUPERSEDES: 3-35/7-22-04

TAMPA ELECTRIC CO. STANDARDS GENERAL RULES & SPECIFICATIONS

3-35

NOTE:

- ▶ 1. THE SERVICE TO A LIGHT REQUIRES A 40" CLEARANCE TO THE JOINT USE ATTACHMENT.
 THE DRIP LOOP REQUIRES ONLY A 12" CLEARANCE TO THE JOINT USE ATTACHMENT.

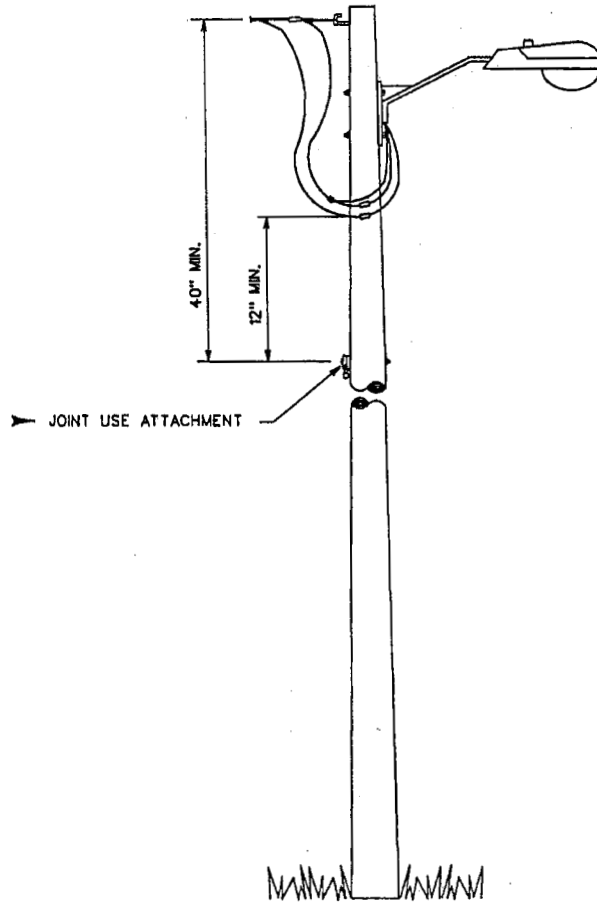

REF. 2002 NESC 238

◀ DENOTES LATEST REVISION

NO.	CK'D	DATE	REVISION
3			
2	REM	8-18-05	REVISED NOTE 1
1	REM	8-18-05	REVISED JOINT USE BRACKET TO JOINT USE ATTACHMENT

D.S. SUPR. <i>Bob Shindler</i> APPL. DATE 8-18-05 SUPERSEDED 3-36/8-15-02	CLEARANCE FROM LIGHTS TO JOINT USE ATTACHMENT
3-36	TAMPA ELECTRIC CO. STANDARDS GENERAL RULES & SPECIFICATIONS

Attachment B

Authorized Representatives:

Tampa Electric Company
Kristina Angiulli
Manager, E.D. Construction Services
P.O. Box 111
Tampa, Fl., 33601
Phone- 813-275-3022
Fax- 813-275-3409

Tampa Electric Company
Karen Laney
Lead Joint Use Field Technician
P.O. Box 111
Tampa, Fl., 33601
Phone- 813-610-1168
Fax- 813-275-3409

Tampa Electric Company
Eric O'Brien
Joint Use Field Technician
P.O. Box 111
Tampa, Fl., 33601
Phone- 813-610-2476
Fax- 813-275-3005

Tampa Electric Company
Nichole Hogan
Joint Use Billing
P.O. Box 111
Tampa, Fl., 33601
Phone-813-275-3072
Fax-813-275-3409

Attachment D

Approved TEC tracking #: _____ (Number found on approved Exhibit A)
 Company Name: _____
 Contact Name: _____
 Phone Number: _____
 Address: _____

Tampa Electric Company
 Pole Attachment and Contract
 Administration Department
 813-275-3072
 P.O. Box 111
 Tampa , FL 33601

<p><u>Addition or Removal date</u> (please circle addition or removal)</p>	<p>(date of addition or removal)</p>	<p><u>Addition or Removal date</u> (please circle addition or removal)</p>	
<p><u>Grid or Pole ID#:</u></p>	<p>(10 digit GLN preferred if available)</p>	<p><u>Grid or Pole ID#:</u></p>	
<p><u>Asset Tag#</u></p>		<p><u>Asset Tag#</u></p>	
<p><u>Location/address of attachment:</u></p>		<p><u>Location/address of attachment:</u></p>	
<p><u>Type of attachment:</u></p>		<p><u>Type of attachment:</u></p>	
<p><u>Addition or Removal date</u> (please circle addition or removal)</p>		<p><u>Addition or Removal date</u> (please circle addition or removal)</p>	
<p><u>Grid or Pole ID#:</u></p>		<p><u>Grid or Pole ID#:</u></p>	
<p><u>Asset Tag#</u></p>		<p><u>Asset Tag#</u></p>	
<p><u>Location/address of attachment:</u></p>		<p><u>Location/address of attachment:</u></p>	
<p><u>Type of attachment:</u></p>		<p><u>Type of attachment:</u></p>	
<p><u>Addition or Removal date</u> (please circle addition or removal)</p>		<p><u>Addition or Removal date</u> (please circle addition or removal)</p>	
<p><u>Grid or Pole ID#:</u></p>		<p><u>Grid or Pole ID#:</u></p>	
<p><u>Asset Tag#</u></p>		<p><u>Asset Tag#</u></p>	
<p><u>Location/address of attachment:</u></p>		<p><u>Location/address of attachment:</u></p>	
<p><u>Type of attachment:</u></p>		<p><u>Type of attachment:</u></p>	