



FPL

Ten Year Power Plant Site Plan

2012-2021

Submitted To:

***Florida Public
Service Commission***

***Miami, Florida
April 2012***

(This page is intentionally left blank.)

Table of Contents

List of Figures and Tables.....	iii
List of Schedules	iv
Overview of the Document	1
List of Abbreviations	3
Executive Summary	5
I. Description of Existing Resources	13
A. FPL-Owned Resources	15
B. Firm Capacity Power Purchase	22
C. Non-Firm (As Available) Energy	25
D. Demand Side Management (DSM).....	25
II. Forecast of Electric Power Demand	29
A. Overview of the Load Forecasting Process	31
B. Comparison of FPL’s Current and Previous Load Forecasts	32
C. Long-Term Sales Forecasts	33
D. Net Energy for Load	36
E. System Peak Forecasts	37
F. Hourly Load Forecast	38
G. Uncertainty	39
H. DSM	40
III. Projection of Incremental Resource Additions	49
A. FPL’s Resource Planning	51
B. Projected Incremental Resource Additions/Changes	59
C. Discussion of the Projected Resource Plan and Issues Impacting FPL’s Resource Planning Work.....	61
D. Demand Side Management (DSM)	66
E. Transmission Plan.....	71
F. Renewable Resources.....	77
G. FPL’s Fuel Mix and Price Forecasts.....	83
IV. Environmental and Land Use Information	115
A. Protection of the Environment	117
B. FPL’s Environmental Statement	119
C. Environmental Management	119
D. Environmental Assurance Program	120
E. Environmental Communication and Facilitation	120
F. Preferred and Potential Sites	120
1. Preferred Site # 1 - St. Lucie Plant	122
2. Preferred Site # 2 - Turkey Point Plant.....	128
3. Preferred Site # 3 - Cape Canaveral Plant.....	135
4. Preferred Site # 4 - Riviera Plant	140
5. Preferred Site # 5 - Pt. Everglades Plant.....	145

6. Potential Site # 1 - Babcock Ranch	151
7. Potential Site # 2 - DeSoto Solar Expansion	151
8. Potential Site # 3 - Florida Heartland Solar	152
9. Potential Site # 4 - Hendry County	153
10. Potential Site # 5 – Manatee Plant Site.....	154
11. Potential Site #6 – Martin County	155
12. Potential Site # 7 – Northeast Okeechobee County.....	155
13. Potential Site # 8 – Palatka Site	156
14. Potential Site # 9 – Putnam County	157
15. Potential Site # 10 – Space Coast Solar Expansion.....	157
V. Other Planning Assumptions and Information	229
Introduction	231
Discussion Item #1	231
Discussion Item #2	232
Discussion Item #3	233
Discussion Item #4	233
Discussion Item #5	234
Discussion Item #6	234
Discussion Item #7	234
Discussion Item #8	235
Discussion Item #9	236
Discussion Item #10	237
Discussion Item #11	238
Discussion Item #12	239

List of Figures and Tables

Table ES.1	Projected Capacity & Firm Purchase Power Changes.....	10
Table ES.2	Projected Capacity Changes and Reserve Margins for FPL	11
Figure I.A.1	Capacity Resources by Location(Map).....	16
Table I.A.1	Capacity Resource by Unit Type	17
Table I.A.2	Combined Cycle and Combustion Turbine Components	18
Table I.A.3	Purchase Power Resources by Contract.....	19
Figure I.A.2	FPL Substation & Transmission System Configuration (Map)	20
Figure I.A.3	FPL Interconnection Diagram.....	21
Table I.B.1	FPL’s Firm Purchased Power Summer MW	23
Table I.B.2	FPL’s Firm Purchased Power Winter MW.....	24
Table I.C.1	As-Available Energy Purchases From Non-Utility Generators in 2011	25
Figure III.A.1	Overview of FPL’s IRP Process.....	52
Table III.B.1	Projected Capacity Changes for FPL.....	60
Table III.D.1	FPL’s Projected DSM Summer MW Reduction for 2012 - 2021	70
Table III.E.1	List of Proposed Power Lines	71
Table IV.E.1	2011 FPL Environmental Outreach Activities	120
	Preferred Site # 1 - St. Lucie Plant Maps	159
	Preferred Site # 2 - Turkey Point Plant Maps	165
	Preferred Site # 3 - Cape Canaveral Plant Maps	171
	Preferred Site # 4 - Riviera Plant Maps	177
	Preferred Site # 5 - Port Everglades Plant Maps.....	183
	Potential Site # 1 - Babcock Ranch Maps.....	189
	Potential Site # 2 - DeSoto Solar Expansion Maps.....	193
	Potential Site # 3 - Florida Heartland Solar Maps	197
	Potential Site # 4 - Hendry County Maps	201
	Potential Site # 5 - Manatee Plant Maps.....	205
	Potential Site # 6 – Martin County Maps.....	209
	Potential Site # 7 - Northeast Okeechobee County Maps	213
	Potential Site # 8 – Palatka Site Maps.....	217
	Potential Site # 9 – Putnam County Maps	221
	Potential Site # 10– Space Coast Solar Expansion Maps	225

List of Schedules

Schedule 1	Existing Generating Facilities.....	26
Schedule 2.1	History and Forecast of Energy Consumption & Number of Customers by Customer Class (Rural & Residential).....	41
Schedule 2.2	History and Forecast of Energy Consumption & Number of Customers by Customer Class (Industrial).....	42
Schedule 2.3	History and Forecast of Energy Consumption & Number of Customers by Customer Class (Sales for Resale).....	43
Schedule 3.1	History and Forecast of Summer Peak Demand (Base Case).....	44
Schedule 3.2	History and Forecast of Winter Peak Demand (Base Case).....	45
Schedule 3.3	History and Forecast of Annual Net Energy for Load GWH (Base Case).....	46
Schedule 4	Previous Year Actual and Two-Year Forecast of Retail Peak Demand and Net Energy for Load by Month.....	47
Schedule 5	Fuel Requirements.....	90
Schedule 6.1	Energy Sources.....	91
Schedule 6.2	Energy Sources % by Fuel Type.....	92
Schedule 7.1	Forecast of Capacity, Demand and Scheduled Maintenance at Time of Summer Peak.....	93
Schedule 7.2	Forecast of Capacity, Demand and Scheduled Maintenance at Time of Winter Peak.....	94
Schedule 7.3	Projection of Generation-Only Reserve at time of Summer Peak with no 2016 or 2021 Generation Additions.....	95
Schedule 7.4	Projection of Generation-Only Reserve at time of Summer Peak with 2016 or 2021 Generation Additions.....	96
Schedule 8	Planned and Prospective Generating Facility Additions and Changes.....	97
Schedule 9	Status Report and Specifications of Proposed Generating Facilities.....	99
Schedule 10	Status Report and Specifications of Proposed Transmission Lines.....	106
Schedule 11.1	Existing Firm and Non-Firm Capacity & Energy by Primary Fuel Type.....	113
Schedule 11.2	Existing Non- Firm Self-Service Renewable Generation Facilities.....	113

Overview of the Document

Chapter 186, Florida Statutes, requires that each electric utility in the State of Florida with a minimum existing generating capacity of 250 megawatts (MW) must annually submit a Ten Year Power Plant Site Plan. This plan should include an estimate of the utility's future electric power generating needs, a projection of how these estimated generating needs might be met, and disclosure of information pertaining to the utility's preferred and potential power plant sites. The information contained in this Site Plan is compiled and presented in accordance with rules 25-22.070, 25-22.071, and 25-22.072, Florida Administrative Code (F.A.C.).

This Ten Year Power Plant Site Plan (Site Plan) document is based on Florida Power & Light Company's (FPL) integrated resource planning (IRP) analyses that were carried out in 2011 and that were on-going in the first Quarter of 2012. The forecasted information presented in this plan addresses the years 2012 through 2021.

Site Plans are long-term planning documents and should be viewed in this context. A Site Plan contains tentative information and all of this information is subject to change at the discretion of the utility. Much of the data submitted is preliminary in nature and is presented in a general manner. Specific and detailed data will be submitted as part of the Florida site certification process, or through other proceedings and filings, at the appropriate time.

This document is organized in the following manner:

Chapter I – Description of Existing Resources

This chapter provides an overview of FPL's current generating facilities. Also included is information on other FPL resources including purchased power, demand side management, and FPL's transmission system.

Chapter II – Forecast of Electric Power Demand

FPL's load forecasting methodology, and its forecast of seasonal peaks and annual energy usage, is presented in Chapter II.

Chapter III – Projection of Incremental Resource Additions

This chapter discusses FPL's integrated resource planning (IRP) process and outlines FPL's projected resource additions, especially new power plants, based on FPL's IRP work in 2011 and

early 2012.

Chapter IV – Environmental and Land Use Information

This chapter discusses environmental information as well as Preferred and Potential site locations for additional electric generation facilities.

Chapter V – Other Planning Assumptions and Information

This chapter addresses twelve “discussion items” which pertain to additional information that is included in a Site Plan filing.

FPL List of Abbreviations Used in FPL Forms		
Reference	Abbreviation	Definition
Unit Type	BIT	Bituminous Coal
	CC	Combined Cycle
	CT	Combustion Turbine
	GT	Gas Turbine
	IC	Internal Combustion
	NP	Nuclear Power
	PV	Photovoltaic
	ST	Steam Unit
Fuel Type	UR	Uranium
	BIT	Bituminous Coal
	FO2	#1, #2 or Kerosene Oil (Distillate)
	FO6	#4,#5,#6 Oil (Heavy)
	NG	Natural Gas
	No	None
	Solar	Solar Energy
	SUB	Sub Bituminous Coal
	Pet	Petroleum Coke
Fuel Transportation	No	None
	PL	Pipeline
	RR	Railroad
	TK	Truck
	WA	Water
Unit/Site Status	OT	Other
	P	Planned Unit
	T	Regulatory approval received but not under construction
	U	Under construction, less than or equal to 50% Complete
	V	Under construction, more than 50% Complete
Other	ESP	Electrostatic Precipitators

(This page is left intentionally blank.)

Executive Summary

Florida Power & Light Company's (FPL) 2012 Ten Year Power Plant Site Plan (Site Plan) presents FPL's current plans to augment and enhance its electric generation capability (owned or purchased) as part of its efforts to meet its projected incremental resource needs for the 2012 - 2021 time period. By design, the primary focus of this document is on supply side additions; i.e., electric generation capability and the sites for these additions. The supply side additions discussed in this document are resources projected to be needed after accounting for FPL's demand side management (DSM) efforts and the significant energy efficiency contributions from the current federal appliance and lighting efficiency standards. The projected impacts of the federal appliance and lighting efficiency standards are accounted for in FPL's load forecast which is discussed in Chapter II. The projected impacts of FPL's DSM efforts are addressed as projected reductions to the forecasted load. FPL's DSM programs are presented in Chapter III.

The resource plan that is presented in FPL's 2012 Site Plan contains a number of key similarities to the resource plan presented in FPL's 2011 Site Plan. On the other hand, there are specific factors that result in changes in FPL's current resource plan compared to the resource plan presented in FPL's 2011 Site Plan. There are also other factors that will continue to influence FPL's on-going resource planning work. A brief discussion of these similarities, changes, and factors is provided below. Additional information regarding many of these topics is presented in Chapter III.

I. Similarities to the Resource Plan Previously Presented in FPL's 2011 Site Plan:

There are four key similarities in the current resource plan presented in this document compared to the resource plan presented in the 2011 Site Plan.

Similarity # 1: Generating capacity at FPL's four existing nuclear generation units will continue to increase in the 2012 – 2013 time frame.

FPL will be adding approximately 490 MW of increased generating capacity from "uprates" at its existing Turkey Point and St. Lucie nuclear power plants. 31 MW of this increased capacity has already come in-service at St. Lucie Unit 2 and is already benefiting FPL's customers. The capacity uprates at 3 of the 4 nuclear units are currently projected to be completed by the end of 2012 and the uprate at the 4th unit is projected to be completed by March 2013. The need for these nuclear capacity uprates was approved by the FPSC in January 2008 in Order No. PSC-08-0021-FOF-EI. The Final Order for the Site Certification was issued in September 2008 for the

St. Lucie uprates in Order No. DEP 08-0942 and in October 2008 for the Turkey Point uprates in Order No. DEP 08-1141.¹

Similarity # 2: FPL continues to pursue licenses, permits, and approvals that would be necessary for future construction and operation of two new nuclear generating units at its Turkey Point site.

FPL is continuing its work to obtain all of the licenses, permits, and approvals that would be necessary to construct and operate two new nuclear units at its Turkey Point site in the future. These licenses, permits, and approvals will provide FPL with the opportunity to construct these nuclear units at Turkey Point for a time expected to be up to 20 years from the time the licenses and permits are granted, and then to operate the units for at least 40 years thereafter. The earliest practical deployment dates for the two new units continue to be beyond the 10-year reporting period for this Site Plan. Therefore, these additions are not shown in this document.

Similarity # 3: A number of existing generating units have been placed on Inactive Reserve.

In 2009, FPL began to take a number of its existing generating units out of active service and has placed them on Inactive Reserve status. The specific generating units that have been placed on Inactive Reserve status are discussed in Chapter III of this document. However, there are changes in regard to FPL's current plans for these units that are discussed later in this Executive Summary and in more detail in Chapter III.

Similarity # 4: The modernizations of FPL's existing Cape Canaveral and Riviera plant sites are underway and are projected to be completed on time in 2013 and 2014, respectively.

FPL's 2011 Site Plan projected that the modernizations of these two existing sites would be completed in 2013 (Cape Canaveral) and 2014 (Riviera). FPL received need determination approval from the FPSC for both of these modernizations in September 2008 in Order No. PSC-08-0591-FOF-EI. Site Certification was received for Cape Canaveral in October 2009 in Order No. DEP 09-1015. Site Certification was received for Riviera in November 2009 in Order No. DEP 09-1245. The work to complete these modernizations is underway, on budget and these modernizations are again reflected in this Site Plan with no changes to the projected completion dates.

¹ The nuclear uprate project outage schedules for 2012 and 2013 are still being developed at the time the 2012 Site Plan is being finalized. The project schedule dates presented in this Site Plan document are the best available information available at this time. However, this schedule information is subject to change.

II. Factors That Are Driving Changes in FPL's Resource Plan:

There are two primary factors that are driving changes in FPL's 2012 resource plan compared to the resource plan presented in FPL's 2011 Site Plan. These changes are summarized below.

Factor # 1: It will not be necessary to schedule planned maintenance outages for FPL's fleet of fossil-fueled generating units during all Summer and Winter peak load months.

In FPL's 2011 Site Plan, it was projected that scheduled maintenance for FPL's generating units would need to be extended into all Summer and Winter peak load months. After further analysis, FPL concluded that it would not be necessary to schedule maintenance during all peak load months. (However, FPL will maintain the practice of using available capacity year-round for scheduling maintenance of its fossil-fueled units as opportunities arise.)

Factor # 2: Changes in the load forecast, generating unit capabilities, and power purchase capabilities have combined to result in a net lowering of FPL's projected resource needs through 2021.

The combined effect of several factors has led to a lowering of FPL's projected resource needs. In addition to the aforementioned removal of scheduled maintenance during peak load months, FPL is also projecting a load forecast that is slightly lower than the forecast used in the 2011 Site Plan. Also, several FPL units are now projected to increase their capabilities during the 2012-2021 time frame. These increases include additional incremental generation from the modernization at the Port Everglades site, greater than previously projected output from the nuclear capacity uprates project, and upgrades to the combustion turbines at several of FPL's combined cycle plant sites. The effect of these projects is only slightly offset by a decrease in the amount of a purchased power agreement (PPA) with Palm Beach SWA. However, the combined net effects result in an overall decrease in FPL's projected resource needs.

III. Resulting Changes in FPL's Resource Plan Compared to the Resource Plan Previously Presented in FPL's 2011 Site Plan:

The combined effect of the factors discussed above contributed to three significant changes in FPL's resource plan presented in this document compared to the resource plan previously

presented in FPL's 2011 Site Plan. These changes are presented below and are discussed in more detail in Chapter III.

Change # 1: FPL's next resource need will be met by the modernization of FPL's Port Everglades site.

In its 2011 Site Plan, FPL projected, for planning purposes, to meet its next resource need with a Greenfield combined cycle (CC) unit that would come in-service in 2016. However, FPL discussed in its 2011 Site Plan that FPL was examining a variety of options with which to meet this need including a modernization of the Port Everglades site. Subsequent analyses determined that a modernization of this site was the most economic and best option for FPL's customers. FPL filed for a need determination for the modernization on November 21, 2011. The FPSC voted on March 27, 2012, to approve the modernization of Port Everglades with a 2016 in-service date. (As a result, Port Everglades' existing generating units 1 – 4, currently on Inactive Reserve status, will eventually be removed as part of the modernization process.)

Change # 2: Three generating units are being retired and two other generating units have been/will be switched to operate as synchronous condensers.

Sanford Unit 3, Cutler Unit 5, and Cutler Unit 6 are currently on Inactive Reserve status and will be retired in the fourth quarter of 2012. In addition, Turkey Point Unit 2 has been converted to operate in synchronous condenser mode to provide voltage support for the transmission system in Southeastern Florida. FPL also projects that Turkey Point Unit 1 will be similarly converted to run in synchronous condenser mode starting in 2016.

Change # 3: FPL's next resource need is now projected to be in 2021.

FPL's 2011 Site Plan showed a resource need in 2020 that was originally projected to be met with a Greenfield CC unit. This resource need has moved back one year from 2020 to 2021. FPL has made no decision regarding how this need will be met. For planning purposes, FPL is currently assuming that this 2021 resource need will be met by a PPA in 2021.

IV. Additional Factors Influencing FPL's Resource Planning Work:

In addition to the two factors previously mentioned (no necessity to schedule or execute planned maintenance in all peak load months and a projection of lower resource needs through the end of the 10-year reporting time frame of this document) that are driving changes in FPL's resource plans, there are additional factors that also influence FPL's resource planning work. Among these

other additional factors are two that FPL typically refers to as on-going system concerns that FPL has considered in its resource planning work for a number of years. These two on-going system concerns are: (1) maintaining/enhancing fuel diversity in the FPL system, and (2) maintaining a balance between load and generating capacity in Southeastern Florida, particularly in Miami-Dade and Broward Counties.

A third factor that could affect FPL's resource planning is the possibility of the establishment of a Florida standard for renewable energy or clean energy. A Renewable Portfolio Standard (RPS) proposal was prepared by the FPSC, and then sent to the Florida Legislature for consideration, with a possible change to a Clean Portfolio Standard (CPS), during the 2009 legislative session. However, no RPS or CPS legislation has been enacted in subsequent legislative sessions. Furthermore, during the 2012 legislative session the legislature deleted a now obsolete directive to the FPSC that had instructed them to adopt RPS rules. RPS or CPS legislation, or other legislative initiatives regarding renewable or clean energy contributions, may still occur in the future. If such legislation is enacted in later years, FPL would then determine what steps need to be taken to address the legislation. Such steps would then be discussed in FPL's Site Plan in the year following the enactment of such legislation.

A fourth factor that will affect FPL's resource planning is the issue of how best to reliably obtain additional natural gas for FPL's system which is needed due to growing electrical load. This need for additional natural gas is minimized, but only in part, by the addition of highly fuel-efficient natural gas-fired generating units with the modernizations of the Cape Canaveral, Riviera, and Port Everglades plant sites.

A fifth factor or issue that will affect FPL's resource planning is the extent to which FPL's reserves are projected to become increasingly dependent upon DSM resources as opposed to generation resources. This projected imbalance in future reserves is becoming more pronounced, in part, because of the high level of DSM currently required to be implemented while FPL's projected resource needs have decreased (as previously mentioned).

Each of these factors will continue to be examined in FPL's on-going resource planning work during the rest of 2012 and in future years.

Table ES-1 presents a current projection of major changes to specific generating units and firm capacity purchases for 2012 – 2021 in terms of Summer MW. Table ES-2 then expands upon the information presented in Table ES-1 by adding projections of Winter MW impacts, Summer reserve margins, Winter reserve margins, etc. (Although neither table specifically identifies the

impacts of projected DSM additions on FPL's resource needs and resource plan, FPL's projected DSM additions have been fully accounted for in the resource plan presented in this Site Plan.)

Table ES-1: Projected Capacity & Firm Purchase Power Changes

Year *	Projected Capacity & Firm Purchase Power Changes	Summer MW	Date
2012	Inactive Reserve Unit (PE Units 3 & 4) - active service	761	January-12
	DeSoto 1 Short Term Purchase	150	January-12
	DeSoto 2 Short Term Purchase	155	January-12
	Sanford 5 CT Upgrade	19	March-12
	Palm Beach SWA - PPA extension	40	April-12
	TECO System Gen Short Term Purchase	125	April-12
	Oleander PPA - contract ends	(155)	May-12
	St. Lucie Unit 2 outage	(745)	August-12
	St. Lucie Unit 1 Uprates - completed	129	July-12
Turkey Point Unit 3 Uprates - completed	123	August-12	
Total of MW changes to Summer firm capacity:		602	
2013	TECO System Gen Short Term Purchase	(125)	October-12
	St. Lucie Unit 2 Uprates - completed	84	November-12
	Martin 8 CT Upgrade	10	December-12
	DeSoto 1 Short Term Purchase	(150)	December-12
	DeSoto 2 Short Term Purchase	(155)	December-12
	Inactive Reserve Unit (PE Units 3 & 4) - inactive status	(761)	January-13
	Sanford 5 CT Upgrade	9	February-13
	Turkey Point Unit 4 Uprates - completed	123	March-13
	Sanford 4 CT Upgrade	31	April-12
	Cape Canaveral Next Generation Clean Energy Center	1,210	June-13
Martin 1 ESP - outage	(826)	June-13	
Total of MW changes to Summer firm capacity:		(550)	
2014	Sanford 5 CT Upgrade	10	September-13
	Martin 2 ESP - outage	(826)	March-14
	Manatee 3 CT Upgrade	19	May-14
	Turkey Point 5 CT Upgrade	33	June-14
	Riviera Beach Next Generation Clean Energy Center	1,212	June-14
Total of MW changes to Summer firm capacity:		448	
2015	Manatee 3 CT Upgrade	20	September-14
	Fort Myers 2 CT Upgrades	51	May-15
Total of MW changes to Summer firm capacity:		71	
2016	UPS Replacement	(928)	December-15
	Palm Beach SWA - additional	70	April-16
	Port Everglades Modernization	1,277	June-16
	Turkey Point 1 synchronous condenser	(396)	June-16
Total of MW changes to Summer firm capacity:		23	
2017	SJRPP suspension of energy	(375)	April-17
Total of MW changes to Summer firm capacity:		(375)	
2018			
Total of MW changes to Summer firm capacity:		0	
2019			
Total of MW changes to Summer firm capacity:		0	
2020			
Total of MW changes to Summer firm capacity:		0	
2021	Short Term Purchase	250	May-21
Total of MW changes to Summer firm capacity:		250	

* Year shown reflects when the MW change begins to be accounted for in Summer reserve margin calculations. (Note that addition of MW values for each year will not yield a current cumulative value.)

Table ES-2: Projected Capacity Changes and Reserve Margins for FPL

<i>Projected Capacity Changes and Reserve Margins for FPL ⁽¹⁾</i>					
Year	Projected Capacity Changes	Net Capacity Changes (MW)		Reserve Margin (%) After Maintenance	
		Winter ⁽²⁾	Summer ⁽³⁾	Winter	Summer
2012	Sanford Unit 5 CT Upgrade	---	19		
	Manatee Unit 2	---	(3)		
	St. Lucie Unit 1 Uprate - Outage ⁽⁶⁾	(853)	---		
	St. Lucie Unit 1 Uprates - Completed	---	129		
	Turkey Point Unit 3 Uprates - Completed	---	123		
	St. Lucie Unit 2 Uprate - Outage ⁽⁶⁾	---	(745)		
	Changes to Existing Purchases ⁽⁴⁾	375	470		
	Scherer Unit 4	---	(30)		
	Inactive Reserve Units (PE Units 3 & 4) -return to active status ⁽⁸⁾	765	761		
Manatee Unit 2 ESP - Outage ⁽⁷⁾	(822)	---	31.9%	28.0%	
2013	Cape Canaveral Next Generation Clean Energy Center ⁽⁵⁾	---	1,210		
	Manatee Unit 2	(3)	---		
	Changes to Existing Purchases ⁽⁴⁾	(555)	(430)		
	Sanford Unit 5 CT Upgrade	19	9		
	Martin Unit 8 CT Upgrade	10	10		
	Sanford Unit 4 CT Upgrade	22	31		
	Scherer Unit 4	(28)	---		
	St. Lucie Unit 1 Uprates - Completed	129	---		
	St. Lucie Unit 2 Uprates - Completed	84	84		
	Turkey Point Unit 3 Uprates - Completed	123	---		
	Turkey Point Unit 4 Uprates - Completed	---	123		
	Turkey Point Unit 4 Uprates - Outage ⁽⁵⁾	(717)	---		
	Inactive Reserve Unit (PE Units 3 & 4) - return to inactive status ⁽⁸⁾	(765)	(761)		
	Manatee Unit 1 ESP - Outage ⁽⁷⁾	(822)	---		
Martin Unit 1 ESP - Outage ⁽⁷⁾	--	(826)	26.9%	27.8%	
2014	Cape Canaveral Next Generation Clean Energy Center ⁽⁵⁾	1,355	---		
	Sanford Unit 4 CT Upgrade	16	---		
	Sanford Unit 5 CT Upgrade	19	10		
	Manatee Unit 3 CT Upgrade	---	19		
	Turkey Point Unit 5 CT Upgrade	---	33		
	Turkey Point Unit 4 Uprates - Completed	123	---		
	Martin Unit 1 ESP - Outage ⁽⁷⁾	(832)	---		
	Martin Unit 2 ESP - Outage ⁽⁷⁾	---	(826)		
	Riviera Beach Next Generation Clean Energy Center ⁽⁵⁾	---	1,212	33.6%	26.8%
2015	Manatee Unit 3 CT Upgrade	39	20		
	Turkey Point Unit 5 CT Upgrade	33	---		
	Ft. Myers Unit 2 CT Upgrade	---	51		
	Riviera Beach Next Generation Clean Energy Center ⁽⁵⁾	1,344	---	42.5%	28.6%
2016	Changes to Existing Purchases ⁽⁴⁾	(858)	(858)		
	Ft. Myers Unit 2 CT Upgrade	51	---		
	Turkey Point Unit 1 operation changed to synchronous condenser	---	(396)		
	Port Everglades Next Generation Clean Energy Center ⁽⁵⁾	---	1,277	37.6%	26.4%
2017	Changes to Existing Purchases ⁽⁴⁾	---	(375)		
	Turkey Point Unit 1 operation changed to synchronous condenser	(398)	---		
	Port Everglades Next Generation Clean Energy Center ⁽⁵⁾	1,429	---	41.9%	24.2%
2018	Changes to Existing Purchases ⁽⁴⁾	(383)	---	39.2%	24.1%
2019	---	---	---	38.3%	22.8%
2020	---	---	---	37.2%	20.9%
2021	Short Term Purchase	---	250	36.0%	20.0%

(1) Additional information about these resulting reserve margins and capacity changes are found on Schedules 7 & 8 respectively.
(2) Winter values are forecasted values for January of the year shown.
(3) Summer values are forecasted values for August of the year shown.
(4) These are firm capacity and energy contracts with QF, utilities, and other entities. See Table I.B.1 and Table I.B.2 for more details.
(5) All new unit additions are scheduled to be in-service in June of the year shown. All additions assumed to start in June are included in the Summer reserve margin calculation starting in that year and in the Winter reserve margin calculation starting with the next year.
(6) Outages for uprate work.
(7) Outages for ESP work.
(8) A number of existing FPL power plants have been removed from service and placed on Inactive Reserve status. See Chapter III for a discussion of the units on Inactive Reserves.

(This page is left intentionally blank.)

CHAPTER I

Description of Existing Resources

(This page is left intentionally blank.)

I. Description of Existing Resources

FPL's service area contains approximately 27,650 square miles and has a population of approximately 8.8 million people. FPL served an average of 4,547,051 customer accounts in thirty-five counties during 2011. These customers were served by a variety of resources including: FPL-owned fossil-fueled, renewable, and nuclear generating units, non-utility owned generation, demand side management (DSM), and interchange/purchased power.

I.A. FPL-Owned Resources

The existing FPL generating resources are located at seventeen generating sites distributed geographically around its service territory including one site in Georgia (partial FPL ownership of one unit) and one site in Jacksonville, Florida (partial FPL ownership of two units). The current electrical generating facilities consist of four nuclear units, three coal units, fifteen combined cycle (CC) units, twelve fossil steam units, forty-eight combustion gas turbines, one simple cycle combustion turbine, and two photovoltaic facilities². The locations of these eighty-five generating units are shown on Figure I.A.1 and in Table I.A.1. Table I.A.2 provides a "break down" of the capacity provided by the combustion turbine (CT) and steam turbine (ST) components of FPL's existing CC units.

FPL's bulk transmission system is comprised of 6,721 circuit miles of transmission lines. Integration of the generation, transmission, and distribution system is achieved through FPL's 587 substations in Florida.

The existing FPL system, including generating plants, major transmission stations, and transmission lines, is shown on Figure I.A.2. In addition, Figure I.A.3 shows FPL's interconnection ties with other utilities.

² FPL also has one 75 MW solar thermal facility at its Martin plant site. This facility does not generate electricity as the other units mentioned above do. Instead, it produces steam that reduces the use of fossil fuel to produce steam for electricity generation.

FPL Generating Resources by Location

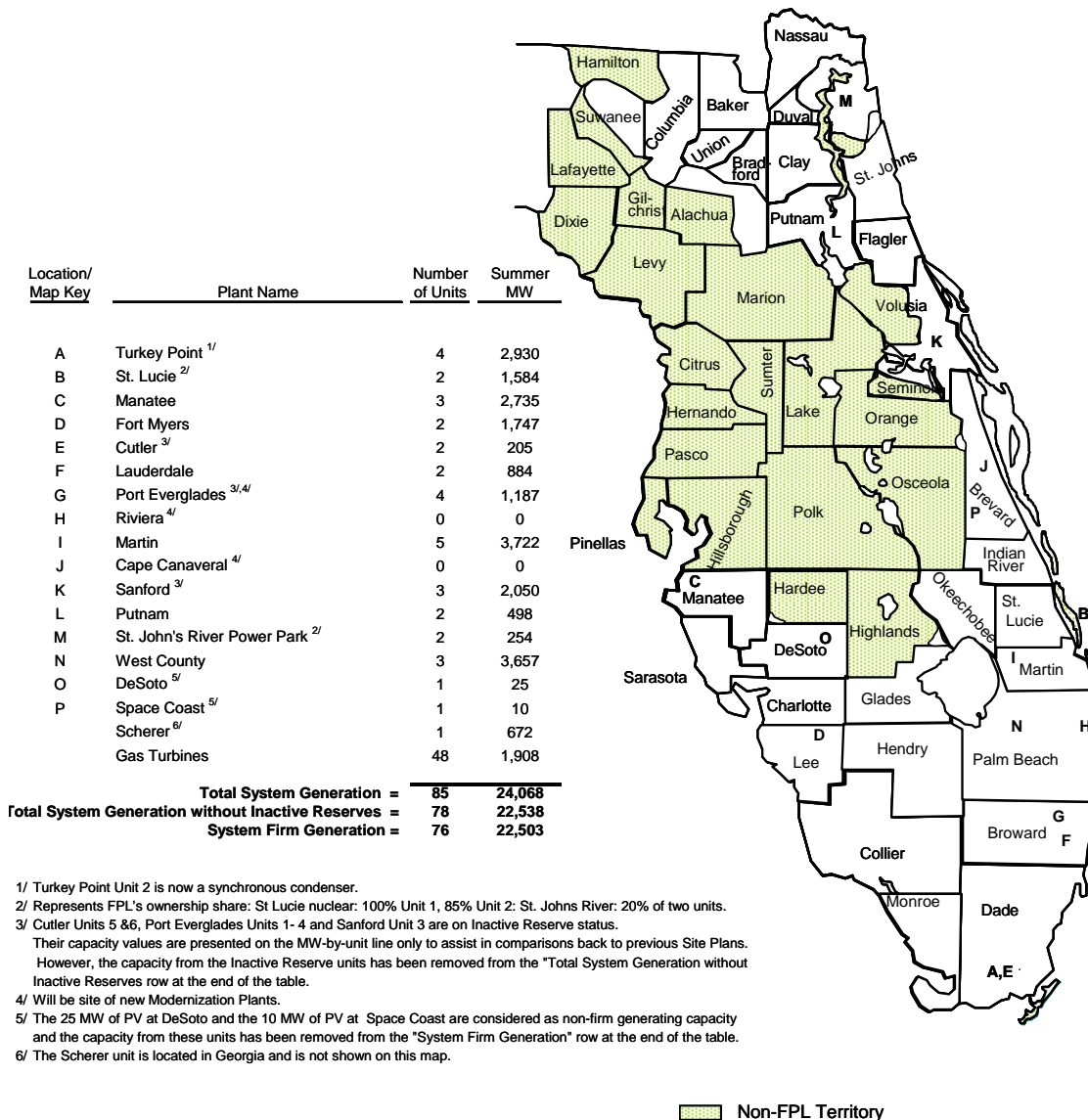

Figure I.A.1: Capacity Resources by Location (as of December 31, 2011)

Table I.A.1: Capacity Resource by Unit Type (as of December 31, 2011)

<u>Unit Type/ Plant Name</u>	<u>Location</u>	<u>Number of Units</u>	<u>Fuel</u>	<u>Summer MW</u>
<u>Nuclear</u>				
Turkey Point	Florida City, FL	2	Nuclear	1,386
St. Lucie ^{1/}	Hutchinson Island, FL	2	Nuclear	1,584
Total Nuclear:		4		2,970
<u>Coal Steam</u>				
SJRPP ^{2/}	Jacksonville, FL	2	Coal	254
Scherer	Monroe County, Ga	1	Coal	672
Total Coal Steam:		3		926
<u>Combined-Cycle</u> ^{3/}				
Sanford	Lake Monroe, FL	2	Gas	1,912
Fort Myers	Fort Myers, FL	1	Gas	1,432
Manatee	Parrish, FL	1	Gas	1,111
Martin	Indiantown, FL	3	Gas	2,070
Turkey Point	Florida City, FL	1	Gas/Oil	1,148
Lauderdale	Dania, FL	2	Gas/Oil	884
Putnam	Palatka, FL	2	Gas/Oil	498
West County	Palm Beach County, FL	3	Gas/Oil	3,657
Total Combined Cycle:		15		12,712
<u>Oil/Gas Steam</u>				
Cutler ^{4/}	Miami, FL	2	Gas	205
Manatee	Parrish, FL	2	Oil/Gas	1,624
Martin	Indiantown, FL	2	Oil/Gas	1,652
Port Everglades ^{4/}	Port Everglades, FL	4	Oil/Gas	1,187
Sanford ^{4/}	Lake Monroe, FL	1	Oil/Gas	138
Turkey Point ^{5/}	Florida City, FL	1	Oil/Gas	396
Total Oil/Gas Steam:		12		5,202
<u>Gas Turbines(GT)/Diesels(IC)</u>				
Lauderdale (GT)	Dania, FL	24	Gas/Oil	840
Port Everglades (GT)	Port Everglades, FL	12	Gas/Oil	420
Fort Myers (GT)	Fort Myers, FL	12	Oil	648
Total Gas Turbines/Diesels:		48		1,908
<u>Combustion Turbines</u> ^{3/}				
Fort Myers ^{6/}	Fort Myers, FL	1	Gas/Oil	315
Total Combustion Turbines:		1		315
<u>PV</u>				
DeSoto ^{7/}	DeSoto, FL	1	Solar Energy	25
Space Coast ^{7/}	Brevard County, FL	1	Solar Energy	10
Total PV:		2		35
Total System Generation as of December 31, 2011 =		85		24,068
Total System Generation without Inactive Reserves as of December 31, 2011 =		78		22,538
System Firm Generation as of December 31, 2011 =		76		22,503

1/ Total capability of each unit is 853/839 MW. FPL's ownership share of St. Lucie Units 1 and 2 is 100% and 85%, respectively.

2/ Capabilities shown represent FPL's output share from each of the units (approx. 92.5% and exclude the Orlando Utilities Commission (OUC) and Florida Municipal Power Agency (FMPA) combined portion of approximately 7.44776% per unit. Represents FPL's ownership share: SJRPP coal: 20% of two units).

3/ The Combined Cycles and Combustion Turbines are broken down by components on Table 1.A.2.

4/ Cutler Units 5 & 6, Port Everglades Units 1-4 and Sanford Unit 3 are on Inactive Reserve status. Their capacity values are presented on the MW-by-unit line only to assist in comparisons back to previous Site Plans. However, the capacity from the Inactive Reserve units has been removed from the "Total System Generation without Inactive Reserves as of December 31, 2011" row at the end of the table.

5/ Turkey Point Unit 2 is now a synchronous condenser.

6/ This unit consists of two combustion turbines.

7/ The 25 MW of PV at DeSoto and the 10 MW of PV at Space Coast are considered as non-firm generating capacity and the capacity from these units has been removed from the "System Firm Generation" row at the end of the table.

Table I.A.2: Combined Cycle and Combustion Turbine Components

		Summer MW *									
Combined-Cycle	Plant Name/ Unit No.	CT	CT	CT	CT	CT	CT	Steam	Steam	BOP	Total Unit MW
		A	B	C	D	E	F	1	2	Aux	
	Ft Myers 2	159	159	159	159	159	159	59	437	(20)	1,433
	Lauderdale 4	158	158	---	---	---	---	131	---	(5)	442
	Lauderdale 5	158	158	---	---	---	---	131	---	(5)	442
	Manatee 3	167	167	167	167	---	---	457	---	(17)	1,109
	Martin 3	166	166	---	---	---	---	144	---	(6)	469
	Martin 4	166	166	---	---	---	---	144	---	(6)	469
	Martin 8	170	170	170	170	---	---	476	---	(23)	1,135
	Putnam 1	71	71	---	---	---	---	112	---	(5)	249
	Putnam 2	71	71	---	---	---	---	112	---	(5)	249
	Sanford 4	160	160	160	160	---	---	328	---	(12)	958
	Sanford 5	159	159	159	159	---	---	330	---	(13)	954
	Turkey Point 5	174	174	174	174	---	---	478	---	(26)	1,149
	West County 1	248	248	248	---	---	---	499	---	(25)	1,219
	West County 2	248	248	248	---	---	---	499	---	(25)	1,219
	West County 3	248	248	248	---	---	---	499	---	(25)	1,219
Combustion Turbines											
	Ft. Myers 3	158	158	---	---	---	---	---	---	(1)	315

This table shows the breakdown of total MW for each unit by CT and steam component.

* The total MW values shown in this table may differ slightly from values shown in other tables due to rounding of per-component values.

Table 1.A.3: Purchase Power Resources by Contract (as of December 31, 2011)

	Location (City or County)	Fuel	Summer MW
<u>I. Purchases from QF's: Cogeneration/Small Power Production Facilities</u>			
Cedar Bay Generating Co.	Duval	Coal (Cogen)	250
Indiantown Cogen., LP	Martin	Coal (Cogen)	330
Broward South	Broward	Solid Waste	4
Broward North	Broward	Solid Waste	11
		Total:	595
<u>II. Purchases from Utilities:</u>			
UPS from Southern Company	Various in Georgia	Coal	928
SJRPP	Jacksonville, FL	Coal	375
		Total:	1,303
<u>III. Other Purchases:</u>			
Oleander (Extension)	Brevard	Gas	155
			155
		Total Net Firm Generating Capability:	2,053

<u>Non-Firm Energy Purchases (MWH)</u>			
Project	County	Fuel	Energy (MWH) Delivered to FPL in 2011
Okeelanta (known as Florida Crystals and New Hope Power Partners)	Palm Beach	Bagasse/Wood	172,050
Broward South	Broward	Garbage	289,953
Tomoka Farms	Volusia	Landfill Gas	0
Waste Management - Renewable Energy	Broward	Landfill Gas	59,719
Waste Management - Collier County Landfill	Broward	Landfill Gas	18,046
Tropicana	Manatee	Natural Gas	30,532
Calnetix	Palm Beach	Natural Gas	0
Georgia Pacific	Putnam	Paper by-product	2,013
Rothenbach Park (known as MMA Bee Ridge)	Sarasota	PV	321
First Solar	Miami	PV	10
Customer - Owned PV & Wind	Various	PV/Wind	415
Palm Beach SWA	Palm Beach	Solid Waste	346,035

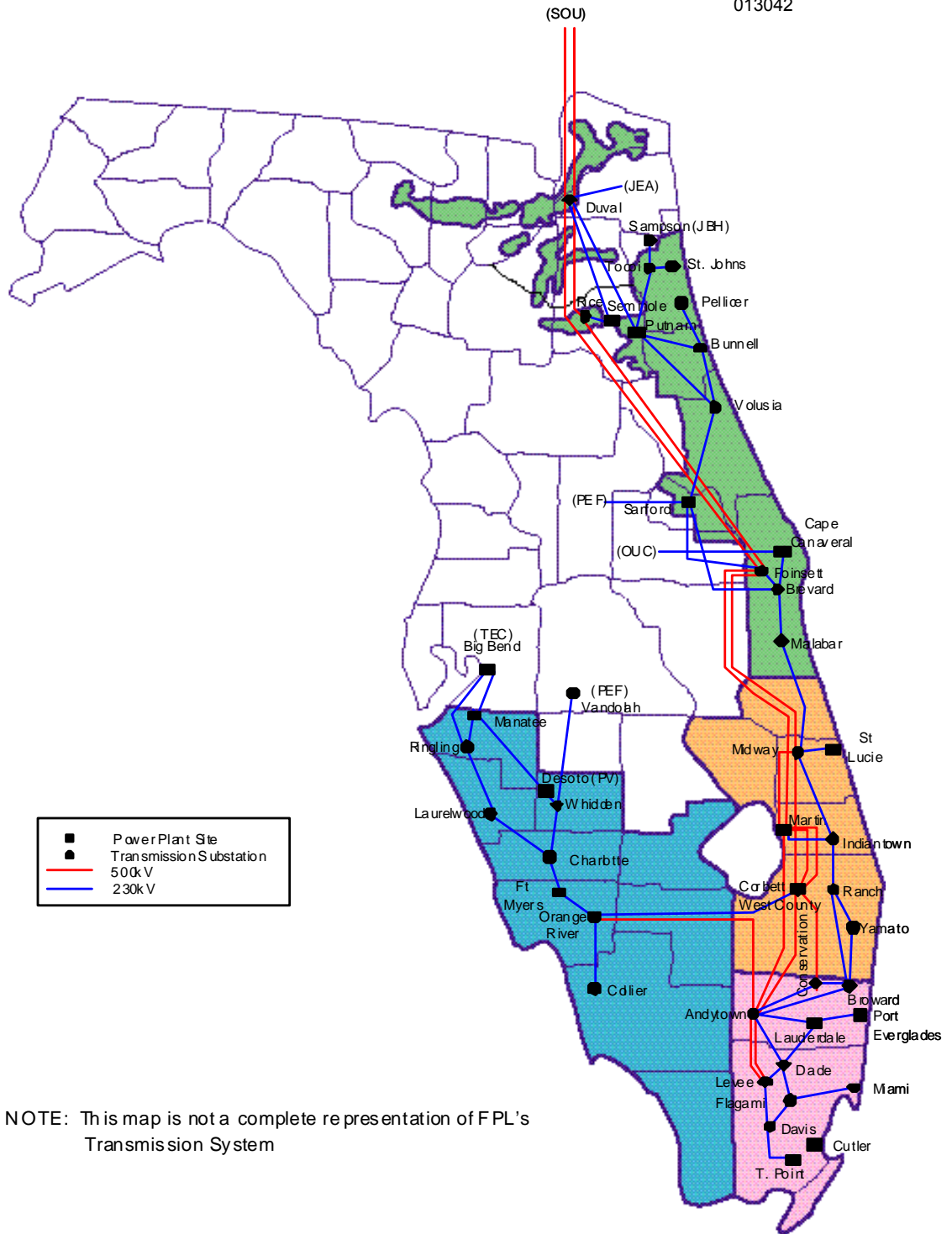

Figure I.A.2: FPL Substation and Transmission System Configuration

FPL Interconnection Diagram

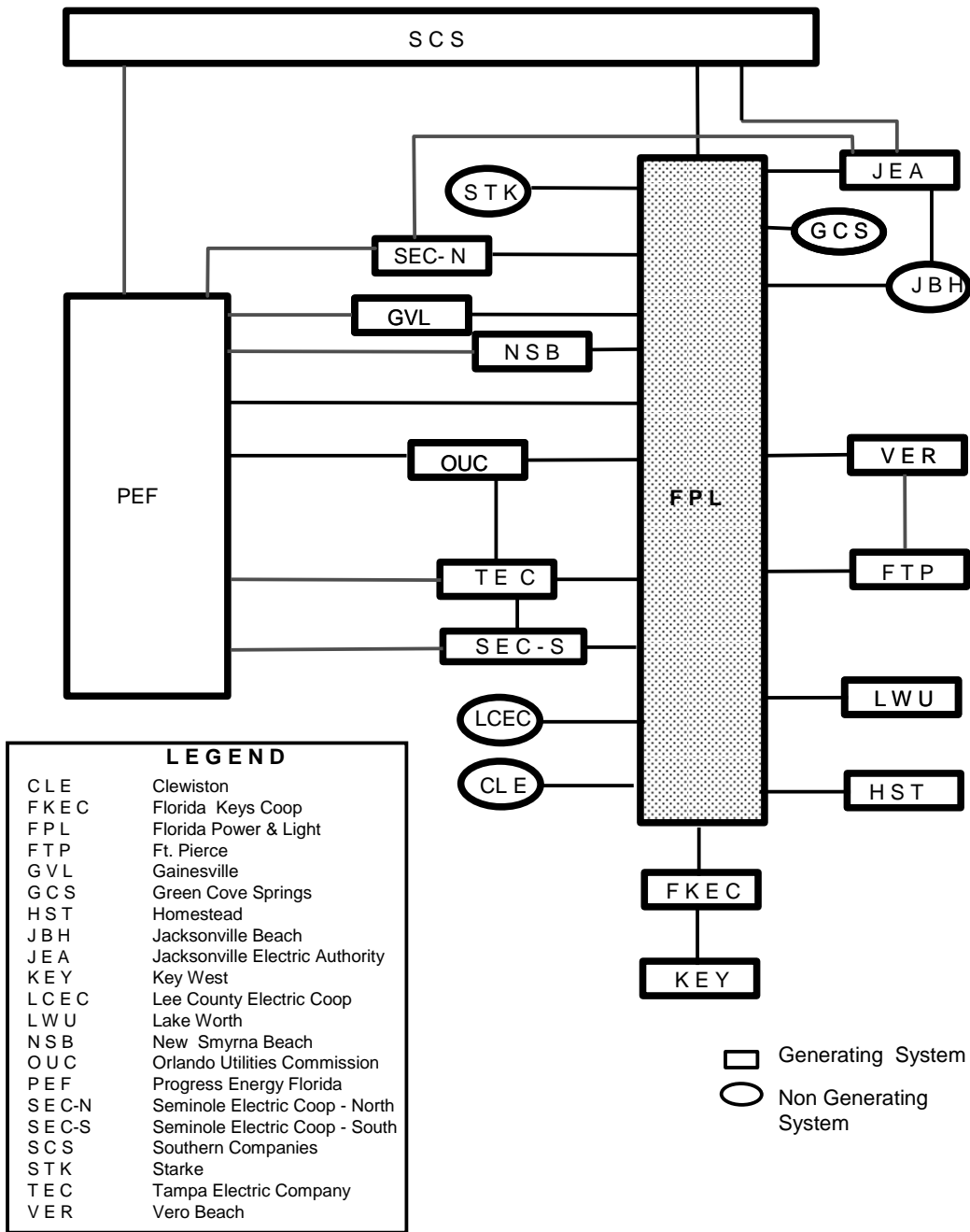

Figure I.A.3: FPL Interconnection Diagram

I.B Firm Capacity Power Purchases

Purchases from Qualifying Facilities (QF):

Firm capacity power purchases are an important part of FPL's resource mix. FPL currently has contracts with five qualifying facilities; i.e., cogeneration/small power production facilities, to purchase firm capacity and energy as shown in Table I.A.3, Table I.B.1, and Table I.B.2.

A cogeneration facility is one which simultaneously produces electrical and thermal energy, with the thermal energy (e.g., steam) being used for industrial, commercial, or cooling and heating purposes. A small power production facility is one which does not exceed 80 MW (unless it is exempted from this size limitation by the Solar, Wind, Waste, and Geothermal Power Production Incentives Act of 1990) and uses as its primary energy source (at least 50%) solar, wind, waste, geothermal, or other renewable resources.

Purchases from Utilities:

FPL has a Unit Power Sales (UPS) contract to purchase 928 MW from the Southern Company (Southern) through the end of December 2015. This capacity will be supplied by Southern from a mix of gas-fired and coal-fired units.

In addition, FPL has contracts with the Jacksonville Electric Authority (JEA) for the purchase of 375 MW (Summer) and 383 MW (Winter) of coal-fired generation from the St. John's River Power Park (SJRPP) Units No. 1 and No. 2. However, due to Internal Revenue Service (IRS) regulations, the total amount of energy that FPL may receive from this purchase is limited. FPL currently assumes, for planning purposes, that this limit will be reached in the Spring of 2017. Once this limit is reached, FPL will be unable to receive firm capacity and energy from these purchases. (However, FPL will continue to receive firm capacity and energy from its ownership portion of the SJRPP units.)

FPL has an additional one-year contract with TECO for 125 MW of firm capacity through December 2012.

These purchases are shown in Table I.A.3, Table I.B.1, and Table I.B.2. FPL also has ownership interest in the SJRPP units. The ownership amount is reflected in FPL's installed capacity shown on Figure I.A.1, in Table I.A.1, and on Schedule 1.

Other Purchases:

FPL has three other short-term firm capacity purchase contracts with non-QF, non-utility suppliers. One of these purchase contracts runs through May 2012 and the other two run through December 2012. Table I.B.1 and I.B.2 present the Summer and Winter MW, respectively, resulting from these contracts under the category heading of Other Purchases.

Table I.B.1: FPL's Firm Purchased Power Summer MW

Summary of FPL's Firm Capacity Purchases: Summer MW (for August of Year Shown)

I. Purchases from QF's:												
Cogeneration Small Power Production Facilities	Contract Start Date	Contract End Date	2012	2013	2014	2015	2016	2017	2018	2019	2020	2021
			Broward South	01/01/93	12/31/26	1.4	1.4	1.4	1.4	1.4	1.4	1.4
Broward South	01/01/95	12/31/26	1.5	1.5	1.5	1.5	1.5	1.5	1.5	1.5	1.5	1.5
Broward South	01/01/97	12/31/26	0.6	0.6	0.6	0.6	0.6	0.6	0.6	0.6	0.6	0.6
Broward North	01/01/93	12/31/26	7	7	7	7	7	7	7	7	7	7
Broward North	01/01/95	12/31/26	1.5	1.5	1.5	1.5	1.5	1.5	1.5	1.5	1.5	1.5
Broward North	01/01/97	12/31/26	2.5	2.5	2.5	2.5	2.5	2.5	2.5	2.5	2.5	2.5
Cedar Bay Generating Co.	01/25/94	12/31/24	250	250	250	250	250	250	250	250	250	250
Indiantown Cogen., LP	12/22/95	12/01/25	330	330	330	330	330	330	330	330	330	330
Palm Beach SWA - extension	01/01/12	04/01/32	40	40	40	40	40	40	40	40	40	40
Palm Beach SWA - additional	04/01/16	04/01/32	0	0	0	0	70	70	70	70	70	70
QF Purchases Sub Total:			635	635	635	635	705	705	705	705	705	705
II. Purchases from Utilities:												
	Contract Start Date	Contract End Date	2012	2013	2014	2015	2016	2017	2018	2019	2020	2021
			UPS Replacement	06/01/10	12/31/15	928	928	928	928	0	0	0
SJRPP	04/02/82	04/01/17 *	375	375	375	375	375	0	0	0	0	0
TECO	01/01/12	12/31/12	125	0	0	0	0	0	0	0	0	0
Utility Purchases Sub Total:			1,428	1,303	1,303	1,303	375	0	0	0	0	0
Total of QF and Utility Purchases =			2,063	1,938	1,938	1,938	1,080	705	705	705	705	705
III. Other Purchases:												
	Contract Start Date	Contract End Date	2012	2013	2014	2015	2016	2017	2018	2019	2020	2021
			Oleander (Extension)	06/01/07	05/31/12	0	0	0	0	0	0	0
DeSoto Unit 1	01/01/12	12/31/12	150	0	0	0	0	0	0	0	0	0
DeSoto Unit 2	01/01/12	12/31/12	155	0	0	0	0	0	0	0	0	0
Other Purchases Sub Total:			305	0	0	0	0	0	0	0	0	0
Total "Non-QF" Purchase =			1,733	1,303	1,303	1,303	375	0	0	0	0	0
Summer Firm Capacity Purchases Total MW:			2,368	1,938	1,938	1,938	1,080	705	705	705	705	705

* Contract End Date shown for the SJRPP purchase does not represent the actual contract end date. Instead, this date represents a projection of the earliest date at which FPL's ability to receive further capacity and energy from this purchase could be suspended due to IRS regulations.

Table I.B.2: FPL's Firm Purchased Power Winter MW

Summary of FPL's Firm Capacity Purchases: Winter MW (for January of Year Shown)

I. Purchases from QF's:

Cogeneration Small Power Production Facilities	Contract Start Date	Contract End Date										
			2012	2013	2014	2015	2016	2017	2018	2019	2020	2021
Broward South	01/01/93	12/31/26	1.4	1.4	1.4	1.4	1.4	1.4	1.4	1.4	1.4	1.4
Broward South	01/01/95	12/31/26	1.5	1.5	1.5	1.5	1.5	1.5	1.5	1.5	1.5	1.5
Broward South	01/01/97	12/31/26	0.6	0.6	0.6	0.6	0.6	0.6	0.6	0.6	0.6	0.6
Broward North	01/01/93	12/31/26	7	7	7	7	7	7	7	7	7	7
Broward North	01/01/95	12/31/26	1.5	1.5	1.5	1.5	1.5	1.5	1.5	1.5	1.5	1.5
Broward North	01/01/97	12/31/26	2.5	2.5	2.5	2.5	2.5	2.5	2.5	2.5	2.5	2.5
Cedar Bay Generating Co.	01/25/94	12/31/24	250	250	250	250	250	250	250	250	250	250
Indiantown Cogen., LP	12/22/95	12/01/25	330	330	330	330	330	330	330	330	330	330
Palm Beach SWA - extension	01/01/12	04/01/32	40	40	40	40	40	40	40	40	40	40
Palm Beach SWA - additional	04/01/16	04/01/32	0	0	0	0	70	70	70	70	70	70
QF Purchases Sub Total:			635	635	635	635	705	705	705	705	705	705

II. Purchases from Utilities:

	Contract Start Date	Contract End Date										
			2012	2013	2014	2015	2016	2017	2018	2019	2020	2021
UPS Replacement	06/01/10	12/31/15	928	928	928	928	0	0	0	0	0	0
SJRPP	04/02/82	04/01/17 *	383	383	383	383	383	383	0	0	0	0
TECO	01/01/12	12/31/12	75	0	0	0	0	0	0	0	0	0
Utility Purchases Sub Total:			1,386	1,311	1,311	1,311	383	383	0	0	0	0

Total of QF and Utility Purchases =	2,021	1,946	1,946	1,946	1,088	1,088	705	705	705	705
--	--------------	--------------	--------------	--------------	--------------	--------------	------------	------------	------------	------------

III. Other Purchases:

	Contract Start Date	Contract End Date										
			2012	2013	2014	2015	2016	2017	2018	2019	2020	2021
Oleander (Extension)	06/01/07	05/31/12	180	0	0	0	0	0	0	0	0	0
DeSoto Unit 1	01/01/12	12/31/12	150	0	0	0	0	0	0	0	0	0
DeSoto Unit 2	01/01/12	12/31/12	155	0	0	0	0	0	0	0	0	0
Other Purchases Sub Total:			485	0	0	0	0	0	0	0	0	0

"Non-QF" Purchase =	1,871	1,311	1,311	1,311	383	383	0	0	0	0
----------------------------	--------------	--------------	--------------	--------------	------------	------------	----------	----------	----------	----------

Winter Firm Capacity Purchases Total MW:	2,506	1,946	1,946	1,946	1,088	1,088	705	705	705	705
---	--------------	--------------	--------------	--------------	--------------	--------------	------------	------------	------------	------------

* Contract End Date shown for the SJRPP purchase does not represent the actual contract end date. Instead, this date represents a projection of the earliest date at which FPL's ability to receive further capacity and energy from this purchase could be suspended due to IRS regulations.

I.C Non-Firm (As Available) Energy Purchases

FPL purchases non-firm (as-available) energy from several cogeneration and small power production facilities. Table I.C.1 shows the amount of energy purchased in 2011 from these facilities.

Table I.C.1: As-Available Energy Purchases From Non-Utility Generators in 2011

Project	County	Fuel	In-Service Date	Energy (MWH) Delivered to FPL in 2011
Okeelanta (known as Florida Crystals and New Hope Power Partners)	Palm Beach	Bagasse/Wood	11/95	172,050
Broward South	Broward	Garbage	9/09	289,953
Tomoka Farms	Volusia	Landfill Gas	7/98	0
Waste Management - Renewable Energy	Broward	Landfill Gas	1/10	59,719
Waste Management - Collier County Landfill	Broward	Landfill Gas	5/1/2011	18,046
Tropicana	Manatee	Natural Gas	2/90	30,532
Calnetix	Palm Beach	Natural Gas	7/05	0
Georgia Pacific	Putnam	Paper by-product	2/94	2,013
Rothenbach Park (known as MMA Bee Ridge)	Sarasota	PV	10/07	321
First Solar	Miami	PV	4/1/2011	10
Customer - Owned PV & Wind	Various	PV/Wind	Various	415
Palm Beach SWA	Palm Beach	Solid Waste	4/10	346,035

I.D. Demand Side Management (DSM)

FPL has sought out and implemented cost-effective DSM programs since 1978. These programs include a number of conservation/energy efficiency and load management initiatives. FPL's DSM efforts through 2011 have resulted in a cumulative Summer peak reduction of approximately 4,513 MW at the generator and an estimated cumulative energy saving of approximately 59,890 Gigawatt-hour (GWh) at the generator. After accounting for reserve margin requirements, FPL's DSM efforts through 2011 have eliminated the need to construct the equivalent of more than 13 new 400 MW generating units. DSM is discussed further in Chapter III.

Schedule 1

**Existing Generating Facilities
As of December 31, 2011**

(1)	(2)	(3)	(4)	(5)	(6)	(7)	(8)	(9)	(10)	(11)	(12)	(13)	(14)
Plant Name	Unit No.	Location	Unit Type	Fuel Pri.	Fuel Alt.	Fuel Transport.		Fuel Days Use	Commercial In-Service Month/Year	Actual/Expected Retirement Month/Year	Gen.Max. Nameplate KW	Net Capability ^{1/}	
						Pri.	Alt.					Winter MW	Summer MW
Cape Canaveral ^{2/}		Brevard County 19/24S/36F											
	1		ST	FO6	NG	WA	PL	Unknown	Apr-65	Jun-10	0	0	0
	2		ST	FO6	NG	WA	PL	Unknown	May-69	Jun-10	0	0	0
Cutler ^{3/}		Miami Dade County 27/55S/40E											
	5		ST	NG	No	PL	No	Unknown	Nov-54	Nov-12	236,500	207	205
	6		ST	NG	No	PL	No	Unknown	Jul-55	Nov-12	161,500	138	137
DeSoto ^{4/}		DeSoto County 27/36S/25E											
	1		PV	N/A	N/A	N/A	N/A	Unknown	Oct-09	Unknown	27,000	25	25
Fort Myers		Lee County 35/43S/25E											
	2		CC	NG	No	PL	No	Unknown	Jun-02	Unknown	2,895,890	2,552	2,395
	3A & B		CT	NG	FO2	PL	PL	Unknown	Jun-03	Unknown	1,775,390	1,490	1,432
	1-12		GT	FO2	No	PL	No	Unknown	May-74	Unknown	376,380	352	315
											744,120	710	648
Lauderdale		Broward County 30/50S/42E											
	4		CC	NG	FO2	PL	PL	Unknown	May-93	Unknown	1,873,968	1,884	1,724
	5		CC	NG	FO2	PL	PL	Unknown	Jun-93	Unknown	526,250	483	442
	1-12		GT	NG	FO2	PL	PL	Unknown	Aug-70	Unknown	526,250	483	442
	13-24		GT	NG	FO2	PL	PL	Unknown	Aug-70	Unknown	410,734	459	420
											410,734	459	420
Manatee		Manatee County 18/33S/20E											
	1		ST	FO6	NG	WA	PL	Unknown	Oct-76	Unknown	2,951,110	2,812	2,735
	2		ST	FO6	NG	WA	PL	Unknown	Dec-77	Unknown	863,300	822	812
	3		CC	NG	No	PL	No	Unknown	Jun-05	Unknown	863,300	822	812
											1,224,510	1,168	1,111

1/ These ratings are peak capability.

2/ The Cape Canaveral modernization project has resulted in the removal of the two steam units previously at the Canaveral site to clear the site for the introduction of a new combined cycle generating unit. This new unit is projected to go into service in June 2013.

3/ Cutler Units 5 & 6 are on Inactive Reserve status. Their capacity values are presented on the MW-by-unit line only to assist in comparisons back to previous Site Plans. However, the capacity from the Inactive Reserve units has been removed from the "Total System Generation without Inactive Reserves as of December 31, 2011" row at the end of the table. Cutler Units 5 & 6 will be retired by the end of 2012.

4/ The capacity shown for the PV facility at DeSoto is considered as non-firm generating capacity and the capacity from these units has been removed from the "System Firm Generating Capacity as of December 31, 2011" row at the end of the table.

Schedule 1

**Existing Generating Facilities
As of December 31, 2011**

(1)	(2)	(3)	(4)	(5)	(6)	(7)	(8)	(9)	(10)	(11)	(12)	(13)	(14)
Plant Name	Unit No.	Location	Unit Type	Fuel		Fuel Transport		Fuel Days Use	Commercial In-Service Month/Year	Actual/Expected Retirement Month/Year	Gen.Max. Nameplate KW	Net Capability ^{1/}	
				Pri.	Alt.	Pri.	Alt.					Winter MW	Summer MW
Martin		Martin County 29/29S/38E									<u>4,317,510</u>	<u>3,861</u>	<u>3,722</u>
	1		ST	FO6	NG	PL	PL	Unknown	Dec-80	Unknown	934,500	832	826
	2		ST	FO6	NG	PL	PL	Unknown	Jun-81	Unknown	934,500	832	826
	3		CC	NG	No	PL	No	Unknown	Feb-94	Unknown	612,000	489	469
	4		CC	NG	No	PL	No	Unknown	Apr-94	Unknown	612,000	489	469
	8 ^{2/}		CC	NG	FO2	PL	PL	Unknown	Jun-05	Unknown	1,224,510	1,219	1,132
Port Everglades		City of Hollywood 23/50S/42E									<u>1,665,334</u>	<u>1,652</u>	<u>1,607</u>
	1 ^{3/}		ST	FO6	NG	WA	PL	Unknown	Jun-60	Jan-13	225,250	214	213
	2 ^{3/}		ST	FO6	NG	WA	PL	Unknown	Apr-61	Jan-13	225,250	214	213
	3 ^{3/}		ST	FO6	NG	WA	PL	Unknown	Jul-64	Jan-13	402,050	389	387
	4 ^{3/}		ST	FO6	NG	WA	PL	Unknown	Apr-65	Jan-13	402,050	376	374
	1-12		GT	NG	FO2	PL	PL	Unknown	Aug-71	Unknown	410,734	459	420
Putnam		Putnam County 16/10S/27E									<u>580,008</u>	<u>530</u>	<u>498</u>
	1		CC	NG	FO2	PL	WA	Unknown	Apr-78	Unknown	290,004	265	249
	2		CC	NG	FO2	PL	WA	Unknown	Aug-77	Unknown	290,004	265	249
Riviera		City of Riviera Beach 33/42S/43E									<u>0</u>	<u>0</u>	<u>0</u>
	3		ST	FO6	NG	WA	PL	Unknown	Jun-62	Feb-11	0	0	0
	4		ST	FO6	NG	WA	PL	Unknown	Mar-63	Feb-11	0	0	0
Sanford		Volusia County 16/19S/30E									<u>2,533,970</u>	<u>2,227</u>	<u>2,050</u>
	3 ^{3/}		ST	FO6	NG	WA	PL	Unknown	May-59	Nov-12	156,250	140	138
	4		CC	NG	No	PL	No	Unknown	Oct-03	Unknown	1,188,860	1,040	958
	5		CC	NG	No	PL	No	Unknown	Jun-02	Unknown	1,188,860	1,047	954
Scherer ^{4/}		Monroe, GA									<u>680,368</u>	<u>678</u>	<u>672</u>
	4		BIT	SUB	No	RR	No	Unknown	Jul-89	Unknown	680,368	678	672

1/ These ratings are peak capability.

2/ Martin Unit 8 is also partially fueled by a 75 MW solar thermal facility that supplies steam when adequate sunlight is available, thus reducing fossil fuel use.

3/ Port Everglades Units 1- 4 and Sanford Unit 3 are on Inactive Reserves status. Their capacity values are presented on the MW-by-unit line only to assist in comparisons back to previous Site Plans. However, the capacity from the Inactive Reserve units have been removed from the "Total System Generation without Inactive Reserves as of December 31, 2011" row at the end of the table. Sanford Unit 3 will be retired by the end of 2012.

4/ These ratings represent Florida Power & Light Company's share of Scherer Unit 4, adjusted for transmission losses.

Schedule 1

**Existing Generating Facilities
As of December 31, 2011**

(1)	(2)	(3)	(4)	(5)	(6)	(7)	(8)	(9)	(10)	(11)	(12)	(13)	(14)						
Plant Name	Unit No.	Location	Unit Type	Fuel		Transport		Fuel	Commercial In-Service Month/Year	Actual/Expected Retirement Month/Year	Gen.Max. Nameplate KW	Net Capability ^{1/}							
				Pri.	Alt.	Pri.	Alt.	Use				Winter MW	Summer MW						
Space Coast ^{2/}	Brevard County 13/23S/36E		PV	N/A	N/A	N/A	N/A	Unknown	Apr-10	Unknown	10,000	10	10						
	1																		
St. Johns River Power Park ^{3/}	Duval County 12/15/28E (RPC4)		BIT	BIT	Pet	RR	WA	Unknown	Mar-87	Unknown	135,918	130	127						
	1																		
	2																		
St. Lucie ^{4/}	St. Lucie County 16/36S/41E		NP	UR	No	TK	No	Unknown	May-76	Unknown	850,000	853	839						
	1																		
	2																		
Turkey Point	Miami Dade County 27/57S/40E		ST	FO6	NG	WA	PL	Unknown	Apr-67	Unknown	402,050	398	396						
	1																		
	2 ^{5/}																		
	3																		
	4																		
	5																		
West County	Palm Beach County 29&32/43S/40E		CC	NG	FO2	PL	PL	Unknown	Aug-09	Unknown	1,366,800	1,335	1,219						
	1																		
	2																		
	3																		
Total System Generating Capacity as of December 31, 2011 ^{6/} =											25,323	24,068							
Total System Generation without Inactive Reserves as of December 31, 2011 ^{7/} =											23,783	22,538							
System Firm Generating Capacity as of December 31, 2011 ^{8/} =											23,748	22,503							

1/ These ratings are peak capability.
2 The capacity shown for the PV facility at Space Coast is considered as non-firm generating capacity due to the intermittent nature of the solar resource.
3/ The net capability ratings represent Florida Power & Light Company's share of St. Johns River Park Units 1 and 2, excluding the Jacksonville Electric Authority (JEA) share of 80%.
4/ Total capability of each unit is 853/839 MW. FPL's ownership share of St. Lucie Units 1 and 2 is 100%(853/839) and 85% (714/726), respectively, as shown above. FPL's share of the deliverable capacity from each unit is approx. 92.5% and exclude the Orlando Utilities Commission (OUC) and Florida Municipal Power Agency (FMPA) combined portion of approximately 7.44776% per unit.
5/ This generating unit is currently serving as a synchronous condenser.
6/ The Total System Generating Capacity value shown includes FPL-owned firm and non-firm generating capacity.
7/ The Total System Generation without the Inactive Reserves Units (Cutler Units 5 & 6, Port Everglades Units 1- 4, Sanford Unit 3).
8/ The System Firm Generating Capacity value shown includes only firm generating capacity.

CHAPTER II

Forecast of Electric Power Demand

(This page is left intentionally blank.)

II. Forecast of Electric Power Demand

II. A. Overview of the Load Forecasting Process

Long-term forecasts of sales, net energy for load (NEL), and peak loads are typically developed on an annual basis for resource planning work at FPL. New long-term forecasts were developed by FPL in late 2011 that replaced the previous long-term load forecasts that were used by FPL during 2011 in much of its resource planning work and which were presented in FPL's 2011 Site Plan. These new load forecasts are utilized throughout FPL's 2012 Site Plan. These forecasts are a key input to the models used to develop FPL's integrated resource plan.

The following pages describe how forecasts are developed for each component of the long-term forecast: sales, NEL, and peak loads. Consistent with past forecasts, the primary drivers to develop these forecasts include economic conditions and weather.

The projections for the national and Florida economies are obtained from the consulting firm IHS Global Insight. Population projections are obtained from the Florida Legislature's Office of Economic and Demographic Research (EDR). These projections are developed, in conjunction with the Bureau of Economic and Business Research (BEBR) of the University of Florida. These inputs are quantified and qualified using statistical models in terms of their impact on the future demand for electricity.

Weather is always a key factor that affects FPL's energy sales and peak demand. Three sets of weather variables are developed and used in FPL's forecasting models:

1. Cooling and heating degree-hours based on 72° F, winter heating degree-days based on 66° F, and heating degree-days based on 45° F are used to forecast energy sales.
2. The maximum temperature on the peak day, along with the build-up of cooling degree-hours prior to the peak, are used to forecast Summer peaks.
3. The minimum temperature on the peak day, along with the build-up of heating degree-hours based on 66° F on the day prior to the peak, are used to forecast Winter peaks.

The cooling degree-hours and winter heating degree-days are used to capture the changes in the electric usage of weather-sensitive appliances such as air conditioners and electric space heaters. Heating degree-days based on 45° F are used to capture

heating load resulting from sustained periods of unusually cold weather not fully captured by heating degree-days based on 66° F. A composite hourly temperature profile is derived using hourly temperatures across FPL's service territory. Miami, Ft. Myers, Daytona Beach, and West Palm Beach are the locations from which temperatures are obtained. In developing the composite hourly profile, these regional temperatures are weighted by regional energy sales. The resulting composite temperature is used to derive projected cooling degree-hours and heating degree-days. Similarly, composite temperature and hourly profiles of temperatures are used for the Summer and Winter peak models.

II. B. Comparison of FPL's Current and Previous Load Forecasts

FPL's current load forecast is somewhat lower than the load forecast presented in its 2011 Site Plan. There are three primary factors that are driving the current load forecast: projected population growth, a projection of gradual recovery following the economic recession in Florida, and energy efficiency standards. The net impact of these three factors is that the current load forecast is lower than the 2011 Site Plan forecast.

The customer forecast is based on recent population projections. Population projections are derived from the EDR's August 2011 Demographic Estimating Conference. This forecast indicates generally lower population levels than previously forecasted although long-term rates of population growth are comparable. Net migration into Florida fell to a record low in 2009 during the height of the recession. Florida has since experienced a small rebound in net migration, but population growth rates have remained well below their historical averages. The population growth rate projected for 2012 reflects a continuation of the low rates of population growth Florida has experienced since the start of the recession. Progressively higher rates of population growth are projected until 2016 when population growth approaches the level historically experienced in Florida. Consistent with prior population projection from EDR, the rate of population growth is expected to gradually stabilize after 2016.

FPL's customer base is expected to mirror the state's projected rates of population growth. As population growth recovers, modestly higher customer growth is projected thru 2016, followed by relatively stable growth thereafter. By 2019, the total number of customer accounts (customers) is expected to exceed five million. Between 2012 and 2021, the total number of customers projected in the current load forecast is about 1%

below the levels projected in FPL's 2011 Site Plan, however the longer-term percentage growth rates are comparable.

After suffering for years under the lingering effects of the recent recession, the outlook on the Florida economy is now one of cautious optimism. By year-end 2011, Florida was adding jobs at an annual rate of more than 100,000; more than in any year since 2006. Although significant problems persist in the housing market, the outlook for Florida is for positive, if somewhat modest economic growth. Accordingly, IHS Global Insight is projecting a steady increase in employment and income growth through 2015 after which growth moderates.

Estimates of savings from energy efficiency standards are developed by ITRON, a leading expert in this area. Included in these estimates are savings from federal and state energy efficiency standards, including the 2005 National Energy Policy Act, the 2007 Energy Independence and Security Act, and the savings occurring from the use of compact fluorescent bulbs.³

Consistent with the forecast presented in FPL's 2011 Site Plan, the total growth projected for the ten-year reporting period of this document is significant. The Summer peak is projected to increase to 25,960 MW by 2021, an increase of 4,341 MW over the 2011 actual Summer peak. Likewise, NEL is projected to reach 133,646 GWH in 2021, an increase of 21,192 GWH from the actual 2011 value.

II.C. Long-Term Sales Forecasts

Long-term forecasts of electricity sales were developed for each revenue class and are adjusted to match the NEL forecast. The results of these sales forecasts for the years 2012 - 2021 are presented in Schedules 2.1 - 2.3 which appear at the end of this chapter. Econometric models are developed for each revenue class using the statistical software package MetrixND. The methodologies used to develop energy sales forecasts for each jurisdictional revenue class and NEL forecast are outlined below.

1. Residential Sales

Residential electric usage per customer is estimated by using an econometric model.

Residential sales are a function of: cooling degree-hours, heating degree-hours,

³ Note that in addition to the fact that these energy efficiency standards lower the forecasted load (as described in more detail later in this chapter), these standards also lower the efficiency potential that would otherwise be available through utility DSM programs.

lagged cooling degree-hours, lagged heating degree-hours, a proxy for energy prices, and Florida real per capita income weighted by the percent of the population employed. The impact of weather is captured by the cooling degree-hours, heating degree-hours, and the one month lag of these variables. The proxy for energy prices incorporates the impact of energy prices on electric consumption. As energy prices rise, less disposable income is available for all goods and services, electricity included. To capture economic conditions, the model includes a composite variable based on Florida real per capita income and the percent of the state's population that is employed. Because of the relatively large percentage of Florida's population that has been unemployed during the recession, real per capita income alone does not capture the full magnitude of the downturn. The composite variable more accurately reflects economic conditions. Residential energy sales are forecasted by multiplying the residential use per customer forecast by the number of residential customers forecasted.

2. Commercial Sales

The commercial sales forecast is also developed using an econometric model. Commercial sales are a function of the following variables: Florida real per capita income weighted by the percent of the population employed, cooling degree-hours, heating degree-hours, lagged cooling degree-hours, a variable designed to reflect the impact of empty homes, a dummy variable for the month of December and for the specific month of January 2007, and an autoregressive term. Cooling degree-hours, heating degree-hours, and the one month lag of cooling degree-hours are used to capture weather-sensitive load in the commercial sector.

3. Industrial Sales

The industrial class is comprised of three distinct groups: very small accounts (those with less than 20 kW of demand), medium accounts (those with 21 kW to 499 kW of demand), and large accounts (those with demands of 500 kW or higher). As such, the forecast is developed using a separate econometric model for each group of industrial customers. The small industrial sales model utilizes the following variables: Florida real disposable income, cooling degree-hours, heating degree-hours, a dummy variable for the specific month of February 2009, and an autoregressive term. The medium industrial sales model utilizes the following variables: cooling degree-hours, Florida real disposable income, a dummy variable for the specific month of February 2006, and two autoregressive terms. The large industrial sales model utilizes the following variables: Florida real per capita income, the Consumer Price

Index, the industrial real price of electricity (a 24-month moving average), and a dummy variable for the specific month of October 2004.

4. Railroad and Railways Sales and Street and Highway Sales

This class consists solely of Miami-Dade County's Metrorail system. The projections for railroad and railways sales are based on historical average use per customer which is multiplied by the forecasted number of customers. The number of customers is based on the planned addition of new Metrorail stations.

The forecast for street and highway sales is developed by using a trended use per customer, which is multiplied by the number of forecasted customers.

5. Other Public Authority Sales

This revenue class is closed to new customers. This class consists of sports fields and one government account. The forecast for this class is based on historical knowledge of its usage characteristics.

6. Total Sales to Ultimate Customer

Sales forecasts by revenue class are summed to produce a total sales forecast.

7. Sales for Resale

Sales for resale (wholesale) customers are composed of municipalities and/or electric co-operatives. These customers differ from jurisdictional customers in that they are not the ultimate users of the electricity they buy. Instead, they resell this electricity to their own customers. Currently there are five customers in this class: the Florida Keys Electric Cooperative; City of Key West; Metro-Dade County; Lee County Electric Cooperative; and Wauchula. In addition, FPL will begin making sales to Seminole Electric Cooperative in June 2014 under a long term agreement⁴.

Beginning in May 2011, FPL began providing service to the Florida Keys Electric Cooperative under a long-term full requirements contract. Previously FPL was serving the Florida Keys under a partial requirements contract. The sales to Florida Keys Electric Cooperative are based on customer-supplied information and historical load factors.

⁴ FPL is currently evaluating the possibility of serving the electrical loads of several entities (including Vero Beach and Lake Worth) at the time the 2012 Site Plan is being prepared. Because these possibilities are still being evaluated, the load forecast presented in this Site Plan does not include these potential loads.

FPL's sales to the City of Key West are expected to terminate in 2013. Forecasted sales to the City of Key West are based on assumptions regarding their contract demand and expected load factor.

Metro-Dade County sells 60 MW to Progress Energy Florida. Line losses are billed to Metro-Dade under a wholesale contract. This contract expires in 2013.

Lee County has contracted with FPL for FPL to supply a portion of their load through 2013, then to begin serving their entire load beginning in 2014. This contract began in January 2010. Lee County provides a forecast of their sales by delivery point which is used to derive their sales forecast.

A new contract with Seminole Electric Cooperative is included in the forecast which includes delivery of 200 MW beginning in June 2014.

II.D. Net Energy for Load (NEL)

An econometric model is developed to produce a NEL per customer forecast. The inputs to the model include Florida real per capita income weighted by the percent of the population employed, and a proxy for energy prices. The model also includes three weather variables: Cooling degree-hours, winter heating degree-days, and heating degree-days based on 45° F. In addition, the model also includes variables for weather-sensitive energy efficiency standards and a variable designed to capture the impact of empty homes. Seasonal dummy variables are included for the months of February, April, June, September, and November and the specific months of March 2003, May 2004, and November 2005. There is also an autoregressive term in the model.

The weather-sensitive energy efficiency variable is included to capture the weather sensitive impacts of the 2005 National Energy Policy Act and the 2007 Energy Independence and Security Act. The estimated impact of this factor for the 2012 - 2021 time period is a reduction, on average, of 7,837 GWh per year. This reduction is inclusive of engineering estimates and any resulting behavioral changes. The increase in the number of empty homes resulting from the current housing slump has affected use per customer and is captured in a separate variable. The forecast was also adjusted for additional load estimated from hybrid vehicles, beginning in 2011, which resulted in an increase of approximately 1,010 GWh by the end of the ten-year reporting period. The forecast is also adjusted for projected incremental load resulting from FPL's economic

development riders which will impact the forecast beginning in 2013, and result in an increase, on average, of 311 GWh per year between 2013 and 2021.

The NEL forecast is developed by multiplying the NEL per customer forecast by the total number of customers forecasted. Once the NEL forecast is obtained, total billed sales are computed using a historical ratio of sales to NEL. The sales by class forecasts previously discussed are then adjusted to match the total billed sales. The forecasted NEL values for 2012 - 2021 are presented in Schedule 3.3 that appears at the end of this chapter.

II.E. System Peak Forecasts

The rate of absolute growth in FPL system peak load has been a function of the size of the customer base, varying weather conditions, projected economic conditions, changing patterns of customer behavior (including an increased stock of electricity-consuming appliances), and more efficient appliances and lighting. FPL developed the peak forecast models to capture these behavioral relationships. Impacts of the 2005 National Energy Policy Act, the 2007 Energy Independence and Security Act, and the impact of compact fluorescent light bulbs are taken into account in developing the peak forecast. The estimated impact of these energy efficiency standards for the 2012 - 2021 time frame is a reduction of approximately 692 MW (Summer) and 521 MW (Winter) in 2012, and approximately 1,484 MW (Summer) and 1,360 MW (Winter) by 2021. The forecast was also adjusted for additional load estimated from hybrid vehicles which resulted in an increase of approximately 163 MW in the Summer and 58 MW in the Winter by the end of the ten-year reporting period.

The forecasting methodology of Summer, Winter, and monthly system peaks is discussed below. The forecasted values for Summer and Winter peak loads for the years 2012 – 2021 are presented at the end of this chapter in Schedules 3.1 and 3.2, and in Chapter III in Schedules 7.1 through 7.4.

1. System Summer Peak

The Summer peak forecast is developed using an econometric model. The variables included in the model are the real price of electricity lagged one month, Florida real per capita income weighted by the percent of the population employed, cooling degree-hours in the day prior to the peak, the maximum temperature on the day of the peak, dummy variables for the years 1982, 1989, and 1990, and a variable for energy efficiency standards. The model is based on the Summer peak contribution

per customer and is, therefore, multiplied by total customers, and adjusted to account for incremental loads resulting from hybrid vehicles, new wholesale contracts, and incremental load from FPL's economic development riders to derive FPL's system Summer peak.

2. System Winter Peak

Like the system Summer peak model, this model is also an econometric model. The model consists of two weather-related variables: the minimum temperature on the peak day and heating degree-hours for the prior day squared. The model also includes a dummy variable for winter peaks occurring on weekends and an autoregressive term. The forecasted results are adjusted for the impact of energy efficiency standards. The model is based on the Winter peak contribution per customer and is, therefore, multiplied by total customers, and adjusted to account for incremental loads resulting from hybrid vehicles, new wholesale contracts, and FPL's economic development riders, to derive FPL's system Winter peak.

3. Monthly Peak Forecasts

The forecasting process for monthly peaks consists of the following actions:

- a. Develop the historical seasonal factor for each month by using ratios of historical monthly peaks to the appropriate seasonal peak.
- b. Apply the monthly ratios to their respective seasonal peak forecast to derive the peak forecast by month. This process assumes that the seasonal factors remain unchanged over the forecasting period.

II.F. The Hourly Load Forecast

Forecasted values for system hourly load for the period 2012 - 2021 are produced using a System Load Forecasting "shaper" program. This model uses years of historical FPL hourly system load data to develop load shapes for weekdays, weekend days, and holidays. The model allows calibration of hourly values where the peak is maintained or where both the peak and minimum load-to-peak ratio is maintained.

II.G. Uncertainty

In order to address uncertainty in the forecasts of aggregate peak demand and NEL, FPL first evaluates the assumptions underlying the forecasts. FPL takes a series of steps in evaluating the input variables, including comparing projections from different sources, identifying outliers in the series, and assessing the series' consistency with past forecasts. As needed, FPL reviews additional factors which may affect the input variables.

Uncertainty is also addressed in the modeling process. Generally, econometric models are used to forecast the aggregate peak demand and NEL. During the modeling process, the relevant statistics (goodness of fit, F-statistic, P-values, mean absolute deviation (MAD), mean absolute percentage error (MAPE), etc.) are scrutinized to ensure that the models adequately explain historical variation. Once a forecast is developed, it is compared with past forecasts. Deviations from past forecasts are examined in light of changes in input assumptions to ensure that the drivers underlying the forecast are well understood. Finally, forecasts of aggregate peak demand and NEL are compared with their actual values as they become available. An ongoing process of variance analyses is performed. To the extent that the variance analysis identifies large unexplained deviations between the forecast and actual values, revisions to the econometric model may be considered.

The inherent uncertainty in load forecasting is addressed in different ways in regard to FPL's overall resource planning and operational planning work. In regard to FPL's resource planning work, FPL's utilization of a 20% reserve margin criterion (approved by the FPSC) is designed, in part, to maintain reliable electric service to FPL's customers in light of forecasting uncertainty. In regard to operational planning, an extreme weather load forecast for the projected Summer peak day is developed based on the historical distribution of temperatures on the day of the Summer peak. This produces a probability distribution of Summer peak outcomes with associated probabilities. Likewise, an extreme weather Winter peak forecast is developed based on the historical distribution of temperatures on the day of the Winter peak. Statistical analysis on the distribution of historical weather data is performed to evaluate and understand the impact of extreme weather on the peaks and on NEL, and the likelihood of experiencing extreme weather.

II.H. DSM

The effects of FPL's DSM energy efficiency programs implementation through August 2011 are assumed to be imbedded in the actual usage data for forecasting purposes. Any change in usage pattern, be it the impact of FPL's DSM energy efficiency efforts, price impact, or weather impact, is reflected in the actual observed load data. Therefore, energy efficiency impacts, whether market-driven or as a result of FPL's DSM programs, are assumed to be included in the historical usage data for peaks and NEL.

The impacts of incremental energy efficiency that FPL plans to implement in the future, plus the cumulative and projected incremental impacts of FPL's load management programs, are accounted for as "line item reductions" to the forecasts as part of the IRP process as shown in Schedules 7.1 through 7.4. After making these adjustments to the load forecasts, the resulting "firm" load forecast is then used in FPL's IRP work.

**Schedule 2.1
History and Forecast of Energy Consumption
And Number of Customers by Customer Class
(Historical)**

(1) Year	(2) Population	(3) Members per Household	(4) Rural & Residential			(7) Commercial		
			(4) GWh	(5) Average No. of Customers	(6) Average kWh Consumption Per Customer	(7) GWh	(8) Average No. of Customers	(9) Average kWh Consumption Per Customer
2002	7,898,628	2.21	50,865	3,566,167	14,263	40,029	435,313	91,955
2003	8,079,316	2.21	53,485	3,652,663	14,643	41,425	444,650	93,163
2004	8,247,442	2.20	52,502	3,744,915	14,020	42,064	458,053	91,832
2005	8,469,602	2.21	54,348	3,828,374	14,196	43,468	469,973	92,490
2006	8,620,855	2.21	54,570	3,906,267	13,970	44,487	478,867	92,901
2007	8,729,806	2.19	55,138	3,981,451	13,849	45,921	493,130	93,121
2008	8,771,694	2.20	53,229	3,992,257	13,333	45,561	500,748	90,987
2009	8,732,591	2.19	53,950	3,984,490	13,540	45,025	501,055	89,860
2010	8,762,399	2.19	56,343	4,004,366	14,070	44,544	503,529	88,464
2011	8,810,688	2.19	54,642	4,026,760	13,570	45,052	508,005	88,685

Historical Values (2002 - 2011):

Col. (2) represents population only in the area served by FPL.

Col. (4) and Col. (7) represent actual energy sales including the impacts of existing conservation. These values are at the meter.

Col. (5) and Col. (8) represent the annual average of the twelve month values.

**Schedule 2.1
History and Forecast of Energy Consumption
And Number of Customers by Customer Class
(Projected)**

(1) Year	(2) Population	(3) Members per Household	(4) Rural & Residential			(7) Commercial		
			(4) GWh	(5) Average No. of Customers	(6) Average kWh Consumption Per Customer	(7) GWh	(8) Average No. of Customers	(9) Average kWh Consumption Per Customer
2012	8,907,339	2.20	52,523	4,048,790	12,972	45,624	517,894	88,095
2013	8,986,956	2.20	53,197	4,084,980	13,023	46,666	527,238	88,511
2014	9,101,294	2.20	54,385	4,136,952	13,146	47,882	536,943	89,176
2015	9,239,272	2.20	55,785	4,199,669	13,283	49,215	547,026	89,968
2016	9,384,988	2.20	56,832	4,265,904	13,322	49,965	556,937	89,714
2017	9,522,465	2.20	57,741	4,328,393	13,340	50,568	566,462	89,269
2018	9,654,385	2.20	58,595	4,388,357	13,352	51,166	575,771	88,864
2019	9,785,765	2.20	59,565	4,448,075	13,391	51,761	585,184	88,452
2020	9,916,132	2.20	61,093	4,507,333	13,554	52,760	594,671	88,721
2021	10,044,320	2.20	62,713	4,565,600	13,736	53,970	604,150	89,333

Projected Values (2012 - 2021):

Col. (2) represents population only in the area served by FPL.

Col. (4) and Col. (7) represent forecasted energy sales that do not include the impact of incremental conservation. These values are at the meter.

Col. (5) and Col. (8) represent the annual average of the twelve month values.

Schedule 2.2
History and Forecast of Energy Consumption
And Number of Customers by Customer Class
(Historical)

(1)	(10)	(11)	(12)	(13)	(14)	(15)	(16)
	Industrial			Railroads & Railways	Street & Highway Lighting	Sales to Public Authorities	Sales to Ultimate Consumers
<u>Year</u>	<u>GWh</u>	<u>Average No. of Customers</u>	<u>Average kWh Consumption Per Customer</u>	<u>GWh</u>	<u>GWh</u>	<u>GWh</u>	<u>GWh</u>
2002	4,057	15,533	261,199	89	420	63	95,523
2003	4,004	17,029	235,135	93	425	64	99,496
2004	3,964	18,512	214,139	93	413	58	99,095
2005	3,913	20,392	191,873	95	424	49	102,296
2006	4,036	21,211	190,277	94	422	49	103,659
2007	3,774	18,732	201,499	91	437	53	105,415
2008	3,587	13,377	268,168	81	423	37	102,919
2009	3,245	10,084	321,796	80	422	34	102,755
2010	3,130	8,910	351,318	81	431	28	104,557
2011	3,086	8,691	355,104	82	437	27	103,327

Historical Values (2002 - 2011):

Col. (10) and Col.(15) represent actual energy sales including the impacts of existing conservation. These values are at the meter.

Col. (11) represents the annual average of the twelve month values.

Col. (16) = Col. (4) + Col. (7) + Col. (10) + Col. (13) + Col. (14) + Col. (15).

Schedule 2.2
History and Forecast of Energy Consumption
And Number of Customers by Customer Class
(Projected)

(1)	(10)	(11)	(12)	(13)	(14)	(15)	(16)
	Industrial			Railroads & Railways	Street & Highway Lighting	Sales to Public Authorities	Sales to Ultimate Consumers
<u>Year</u>	<u>GWh</u>	<u>Average No. of Customers</u>	<u>Average kWh Consumption Per Customer</u>	<u>GWh</u>	<u>GWh</u>	<u>GWh</u>	<u>GWh</u>
2012	3,092	8,813	350,834	92	450	28	101,808
2013	3,021	9,174	329,265	93	461	28	103,465
2014	3,045	9,634	316,036	93	471	28	105,903
2015	3,090	10,257	301,272	93	482	27	108,691
2016	3,095	10,787	286,896	93	492	27	110,504
2017	3,042	11,064	274,927	93	503	27	111,972
2018	2,940	11,167	263,278	93	513	27	113,333
2019	2,873	11,316	253,860	93	523	27	114,841
2020	2,831	11,496	246,272	93	533	27	117,336
2021	2,782	11,637	239,091	93	543	27	120,127

Projected Values (2012 - 2021):

Col. (10) and Col.(15) represent forecasted energy sales that do not include the impact of incremental conservation. These values are at the meter.

Col. (11) represents the annual average of the twelve month values.

Col. (16) = Col. (4) + Col. (7) + Col. (10) + Col. (13) + Col. (14) + Col. (15).

**Schedule 2.3
History and Forecast of Energy Consumption
And Number of Customers by Customer Class
(Historical)**

(1)	(17)	(18)	(19)	(20)	(21)
	Sales for	Utility	Net	Average	Total Average
	Resale	Use &	Energy	No. of	Number of
		Losses	For Load	Other	Customers
<u>Year</u>	<u>GWh</u>	<u>GWh</u>	<u>GWh</u>	<u>Customers</u>	<u>Customers</u>
2002	1,233	7,443	104,199	2,792	4,019,805
2003	1,511	7,386	108,393	2,879	4,117,221
2004	1,531	7,467	108,093	3,029	4,224,509
2005	1,506	7,498	111,301	3,156	4,321,895
2006	1,569	7,909	113,137	3,218	4,409,563
2007	1,499	7,401	114,315	3,276	4,496,589
2008	993	7,092	111,004	3,348	4,509,730
2009	1,155	7,394	111,303	3,439	4,499,067
2010	2,049	7,870	114,475	3,523	4,520,328
2011	2,176	6,950	112,454	3,596	4,547,051

Historical Values (2002 - 2011):

Col. (19) represents actual energy sales including the impacts of existing conservation.

Col. (19) = Col. (16) + Col. (17) + Col. (18). Historical NEL includes the impacts of existing conservation and agrees to Col. (5) on schedule 3.3. Historical GWH are based on fiscal calendar. The 2011 value is based on 12/29/10 to 12/31/11.

Col. (20) represents the annual average of the twelve month values.

Col. (21) = Col. (5) + Col. (8) + Col. (11) + Col. (20).

**Schedule 2.3
History and Forecast of Energy Consumption
And Number of Customers by Customer Class
(Projected)**

(1)	(17)	(18)	(19)	(20)	(21)
	Sales for	Utility	Net	Average	Total Average
	Resale	Use &	Energy	No. of	Number of
		Losses	For Load	Other	Customers
<u>Year</u>	<u>GWh</u>	<u>GWh</u>	<u>GWh</u>	<u>Customers</u>	<u>Customers</u>
2012	2,314	7,034	111,156	3,678	4,579,174
2013	2,210	6,812	112,487	3,757	4,625,149
2014	5,013	7,065	117,982	3,836	4,687,365
2015	5,667	7,049	121,407	3,915	4,760,867
2016	5,699	7,107	123,310	3,993	4,837,621
2017	5,657	7,177	124,806	4,069	4,909,988
2018	5,677	7,260	126,270	4,145	4,979,439
2019	5,717	7,360	127,918	4,220	5,048,794
2020	5,768	7,527	130,631	4,294	5,117,793
2021	5,812	7,706	133,646	4,369	5,185,756

Projected Values (2012 - 2021):

Col. (19) represents forecasted energy sales that do not include the impact of incremental conservation and agrees to Col. (2) on Schedule 3.3.

Col. (19) = Col. (16) + Col. (17) + Col. (18). These values are based on calendar year.

Col. (20) represents the annual average of the twelve month values.

Col. (21) = Col. (5) + Col. (8) + Col. (11) + Col. (20).

**Schedule 3.1
History and Forecast of Summer Peak Demand (MW)
(Historical)**

(1)	(2)	(3)	(4)	(5)	(6)	(7)	(8)	(9)	(10)
Year	Total	Wholesale	Retail	Interruptible	Res. Load Management	Residential Conservation	C/I Load Management	C/I Conservation	Net Firm Demand
2002	19,219	261	18,958	0	879	754	489	517	17,851
2003	19,668	253	19,415	0	892	798	577	554	18,200
2004	20,545	258	20,287	0	894	846	588	577	19,063
2005	22,361	264	22,097	0	902	895	600	611	20,858
2006	21,819	256	21,563	0	928	948	635	640	20,256
2007	21,962	261	21,701	0	952	982	716	683	20,295
2008	21,060	181	20,879	0	966	1,042	760	706	19,334
2009	22,351	249	22,102	0	981	1,097	811	732	20,558
2010	22,256	419	21,837	0	990	1,181	815	758	18,512
2011	21,618	427	21,191	0	1,002	1,252	821	776	17,767

Historical Values (2002 - 2011):

Col. (2) - Col. (4) are actual values for historical Summer peaks. As such, they incorporate the effects of conservation (Col. 7 & Col. 9), and may incorporate the effects of load control if load control was operated on these peak days. Therefore, Col. (2) represents the actual Net Firm Demand.

Col. (5) - Col. (9) represent actual DSM capabilities starting from January 1988 and are annual (12-month) values except for 2011 values which are through August. Note that the values for FPL's former Interruptible Rate are incorporated into Col. (8), which also includes Business On Call (BOC), CILC, and Commercial/Industrial Demand Reduction (CDR).

Col. (10) represents a HYPOTHETICAL "Net Firm Demand" as if the load control values had definitely been exercised on the peak. Col. (10) is derived by the formula: Col. (10) = Col.(2) - Col.(6) - Col.(8).

**Schedule 3.1
History and Forecast of Summer Peak Demand (MW)
(Projected)**

(1)	(2)	(3)	(4)	(5)	(6)	(7)	(8)	(9)	(10)
August of Year	Total	Wholesale	Retail	Interruptible	Res. Load Management*	Residential Conservation	C/I Load Management*	C/I Conservation	Net Firm Demand
2012	21,623	432	21,191	0	1,036	64	865	26	19,632
2013	21,931	389	21,542	0	1,048	125	884	58	19,817
2014	23,243	1,187	22,056	0	1,075	190	922	90	20,966
2015	23,786	1,194	22,592	0	1,088	257	940	123	21,378
2016	24,315	1,201	23,114	0	1,101	324	959	155	21,775
2017	24,529	1,195	23,334	0	1,114	391	978	188	21,858
2018	24,674	1,202	23,472	0	1,127	458	996	221	21,871
2019	25,041	1,210	23,832	0	1,140	526	1,015	253	22,107
2020	25,499	1,217	24,282	0	1,156	579	1,028	280	22,456
2021	25,960	1,225	24,735	0	1,172	626	1,042	303	22,816

Projected Values (2012 - 2021):

Col. (2) - Col. (4) represent FPL's forecasted peak w/o incremental conservation, cumulative load management, or incremental load management.

Col. (5) - Col. (9) represent cumulative load management, and incremental conservation and load management. All values are projected August values. The projections for 2012 through 2019 are based on the FPSC's 2011 order in the DSM Plan docket. Projected DSM values for 2020 and 2021 assume 100 MW/year of incremental DSM.

Col. (8) represents FPL's Business On Call, CDR, CILC, and Curtailable programs/rates.

Col. (10) represents a "Net Firm Demand" which accounts for all of the incremental conservation and assumes all of the load control is implemented on the peak. Col. (10) is derived by using the formula: Col. (10) = Col. (2) - Col. (5) - Col. (6) - Col. (7) - Col. (8) - Col. (9).

* Res. Load Management and C/I Load Management include MW values of load management from Lee County.

**Schedule 3.2
History and Forecast of Winter Peak Demand:Base Case
(Historical)**

(1)	(2)	(3)	(4)	(5)	(6)	(7)	(8)	(9)	(10)
Year	Total	Firm Wholesale	Retail	Interruptible	Res. Load Management	Residential Conservation	C/I Load Management	C/I Conservation	Net Firm Demand
2002	17,597	145	17,452	0	768	500	457	196	16,373
2003	20,190	246	19,944	0	802	546	453	206	18,935
2004	14,752	211	14,541	0	813	567	534	227	13,405
2005	18,108	225	17,883	0	816	583	542	233	16,751
2006	19,683	225	19,458	0	823	600	550	240	18,311
2007	16,815	223	16,592	0	846	620	577	249	15,392
2008	18,055	163	17,892	0	868	644	636	279	16,551
2009	20,081	207	19,874	0	881	666	676	285	18,524
2010	24,346	500	23,846	0	895	687	721	291	22,730
2011	21,126	383	20,743	0	903	717	722	303	19,501

Historical Values (2002 - 2011):

Col. (2) - Col. (4) are actual values for historical Winter peaks. As such, they incorporate the effects of conservation (Col. 7 & Col. 9), and may incorporate the effects of load control if load control was operated on these peak days. Therefore, Col. (2) represents the actual Net Firm Demand. For year 2011, the actual peaked occurred in December of 2010.

Col. (5) - Col. (9) for 2002 through 2011 represent actual DSM capabilities starting from January 1988 and are annual (12-month) values. Note that the values for FPL's former Interruptible Rate are incorporated into Col. (8), which also includes Business On Call (BOC), CILC, and Commercial /Industrial Demand Reduction (CDR).

Col. (10) represents a HYPOTHETICAL "Net Firm Demand" as if the load control values had definitely been exercised on the peak. Col. (10) is derived by the formula: Col. (10) = Col.(2) - Col.(6) - Col.(8).

**Schedule 3.2
History and Forecast of Winter Peak Demand:Base Case
(Projected)**

(1)	(2)	(3)	(4)	(5)	(6)	(7)	(8)	(9)	(10)
January of Year	Total	Firm Wholesale	Retail	Interruptible	Res. Load Management*	Residential Conservation	C/I Load Management*	C/I Conservation	Net Firm Demand
2012	20,889	411	20,478	0	1,003	15	652	3	19,216
2013	21,101	413	20,688	0	1,015	74	664	34	19,314
2014	21,959	1,038	20,921	0	1,048	136	695	66	20,014
2015	22,412	1,245	21,167	0	1,060	203	708	99	20,342
2016	22,675	1,252	21,423	0	1,073	271	720	131	20,481
2017	22,902	1,246	21,656	0	1,085	338	732	164	20,584
2018	23,151	1,254	21,897	0	1,097	405	745	197	20,708
2019	23,403	1,261	22,142	0	1,110	472	757	229	20,835
2020	23,667	1,269	22,398	0	1,124	522	767	254	21,000
2021	23,952	1,276	22,675	0	1,139	565	778	275	21,195

Projected Values (2012 - 2021):

Col. (2) - Col.(4) represent FPL's forecasted peak w/o incremental conservation, cumulative load management, or incremental load management.

Col. (5) - Col. (9) represent cumulative load management, and incremental conservation and load management. All values are projected January values. The projections for 2012 through 2019 are based on the FPSC's 2011 order in the DSM Plan docket. Projected DSM values for 2020 and 2021 assume 100 MW/year of incremental DSM.

Col. (8) represents FPL's Business On Call, CDR, CILC, and Curtailable programs/rates.

Col. (10) represents a "Net Firm Demand" which accounts for all of the incremental conservation and assumes all of the load control is implemented on the peak. Col. (10) is derived by using the formula: Col. (10) = Col. (2) - Col. (5) - Col. (6) - Col. (7) - Col. (8) - Col. (9).

* Res. Load Management and C/I Load Management include MW values of load management from Lee County.

Schedule 3.3
History of Annual Net Energy for Load (GWh)
(All values are "at the generator" values except for Col (8))
(Historical)

(1)	(2)	(3)	(4)	(5)	(6)	(7)	(8)	(9)
Year	Net Energy For Load without DSM GWh	Residential Conservation GWh	C/I Conservation GWh	Actual Net Energy For Load GWh	Sales for Resale GWh	Utility Use & Losses GWh	Total Billed Retail Energy Sales (GWh)	Load Factor(%)
2002	107,380	1,682	1,499	104,199	1,233	7,443	95,523	61.9%
2003	111,784	1,773	1,619	108,393	1,511	7,386	99,496	62.9%
2004	111,659	1,872	1,693	108,093	1,531	7,467	99,095	59.9%
2005	115,065	1,970	1,793	111,301	1,506	7,498	102,296	56.8%
2006	117,116	2,078	1,901	113,137	1,569	7,909	103,659	59.2%
2007	118,518	2,138	2,066	114,315	1,499	7,401	105,415	59.4%
2008	115,379	2,249	2,126	111,004	993	7,092	102,919	60.0%
2009	115,844	2,345	2,196	111,303	1,155	7,394	102,755	56.8%
2010	119,220	2,487	2,259	114,475	2,049	7,870	104,557	58.7%
2011	117,460	2,683	2,324	112,454	2,176	6,950	103,327	59.4%

Historical Values (2002 - 2011):

Col. (2) represents derived "Total Net Energy For Load w/o DSM". The values are calculated using the formula: Col. (2) = Col. (3) + Col. (4) + Col. (5).

Col. (3) & Col. (4) are DSM values starting in January 1988 and are annual (12-month) values. Col. (3) and Col. (4) for 2011 are "estimated actuals" and are also annual (12-month) values. The values represent the total GWh reductions experienced each year .

Col. (5) is the actual Net Energy for Load (NEL) for years 2002 - 2011.

Col. (8) is the Total Retail Billed Sales. The values are calculated using the formula: Col. (8) = Col. (5) - Col. (6) - Col. (7). These values are at the meter.

Col. (9) is calculated using Col. (5) from this page and Col. (2), "Total", from Schedule 3.1 using the formula: Col. (9) = ((Col. (5)*1000) / ((Col. (2) * 8760) Adjustments are made for leap years.

Schedule 3.3
History of Annual Net Energy for Load (GWh)
(All values are "at the generator" values except for Col (8))
(Projected)

(1)	(2)	(3)	(4)	(5)	(6)	(7)	(8)	(9)
Year	Forecasted Net Energy For Load without DSM GWh	Residential Conservation GWh	C/I Conservation GWh	Net Energy For Load Adjusted for DSM GWh	Sales for Resale GWh	Utility Use & Losses GWh	Forecasted Total Billed Retail Energy Sales w/o DSM GWh	Load Factor(%)
2012	111,156	87	48	111,021	2,314	7,034	101,808	58.5%
2013	112,487	183	104	112,201	2,210	6,812	103,465	58.6%
2014	117,982	282	162	117,538	5,013	7,065	105,903	57.9%
2015	121,407	383	222	120,802	5,667	7,049	108,691	58.3%
2016	123,310	483	282	122,545	5,699	7,107	110,504	57.7%
2017	124,806	584	342	123,880	5,657	7,177	111,972	58.1%
2018	126,270	685	401	125,183	5,677	7,260	113,333	58.4%
2019	127,918	786	461	126,671	5,717	7,360	114,841	58.3%
2020	130,631	857	503	129,271	5,768	7,527	117,336	58.3%
2021	133,646	927	545	132,174	5,812	7,706	120,127	58.8%

Projected Values (2012 - 2021):

Col. (2) represents Forecasted Net Energy for Load w/o incremental DSM from 2012 - on. The Col. (2) values are extracted from Schedule 2.3, Col. (19). The effects of conservation implemented prior to September 2011 are incorporated into the load forecast values in Col. (2).

Col. (3) & Col. (4) are forecasted values of the reduction on sales from incremental conservation from Jan 2012 - on and are mid-year (6-month) values reflecting DSM signups occurring evenly throughout each year.

Col. (5) is the forecasted Net Energy for Load (NEL) after adjusting for impacts of incremental DSM for years 2012 - 2021 using the formula: Col. (6) = Col. (2) - Col. (3) - Col. (4)

Col. (8) is the Total Retail Billed Sales. The values are calculated using the formula: Col. (8) = Col. (2) - Col. (6) - Col. (7). These values are at the meter.

Col. (9) is calculated using Col. (2) from this page and Col. (2), "Total", from Schedule 3.1. Col. (9) = ((Col. (2)*1000) / ((Col. (2) * 8760) Adjustments are made for leap years.

Schedule 4
Previous Year Actual and Two-Year Forecast of
Retail Peak Demand and Net Energy for Load (NEL) by Month

(1) <u>Month</u>	(2) 2011 ACTUAL		(4) 2012 FORECAST		(6) 2013 FORECAST	
	Total	NEL	Total	NEL	Total	NEL
	Peak Demand MW	GWh	Peak Demand MW	GWh	Peak Demand MW	GWh
JAN	18,552	8,061	20,889	8,291	21,101	8,429
FEB	14,483	7,228	16,965	7,420	17,137	7,547
MAR	16,088	8,082	16,965	8,318	17,137	8,440
APR	19,615	9,730	17,278	8,495	17,524	8,598
MAY	19,747	9,721	19,296	9,804	19,570	9,902
JUN	21,222	10,924	19,572	10,217	19,851	10,279
JUL	21,377	11,848	20,184	11,124	20,471	11,195
AUG	21,619	11,326	21,623	11,103	21,931	11,174
SEP	20,035	10,531	20,061	10,295	20,347	10,380
OCT	18,757	9,051	18,808	9,674	19,076	9,792
NOV	16,831	8,021	17,601	8,089	18,317	8,240
DEC	14,575	7,931	17,616	8,328	18,332	8,511
TOTALS		112,454		111,156		112,487

Col. (3) annual value shown is consistent with value shown in Col.(5) of Schedule 3.3.

Cols. (4) - (7) do not include the impacts of cumulative load management, incremental conservation, and incremental load management and are consistent with values shown in Col. (19) of Schedule 2.3 and Col. (2) of Schedule 3.3.

(This page is left intentionally blank.)

CHAPTER III

Projection of Incremental Resource Additions

(This page is left intentionally blank.)

III. Projection of Incremental Resource Additions

III.A FPL's Resource Planning:

FPL utilizes its well established integrated resource planning (IRP) process in whole or in part as analysis needs warranted, to determine when new resources are needed, what the magnitude of the needed resources are, and what type of resources should be added. The timing and type of new power plants, the primary subjects of this document, are determined as part of the IRP process work.

This section describes FPL's basic IRP process. Some of the key assumptions, in addition to a new load forecast, that were used in developing the resource plan presented in this Site Plan are also discussed.

Four Fundamental Steps of FPL's Resource Planning:

There are 4 fundamental steps to FPL's resource planning. These steps can be described as follows:

Step 1: Determine the magnitude and timing of FPL's new resource needs;

Step 2: Identify which resource options and resource plans can meet the determined magnitude and timing of FPL's resource needs (i.e., identify competing options and resource plans);

Step 3: Evaluate the competing options and resource plans in regard to system economics and non-economic factors; and,

Step 4: Select a resource plan and commit, as needed, to near-term options.

Figure III.A.1 graphically outlines the 4 steps.

Overview of FPL's IRP Process

Fundamental
IRP Steps

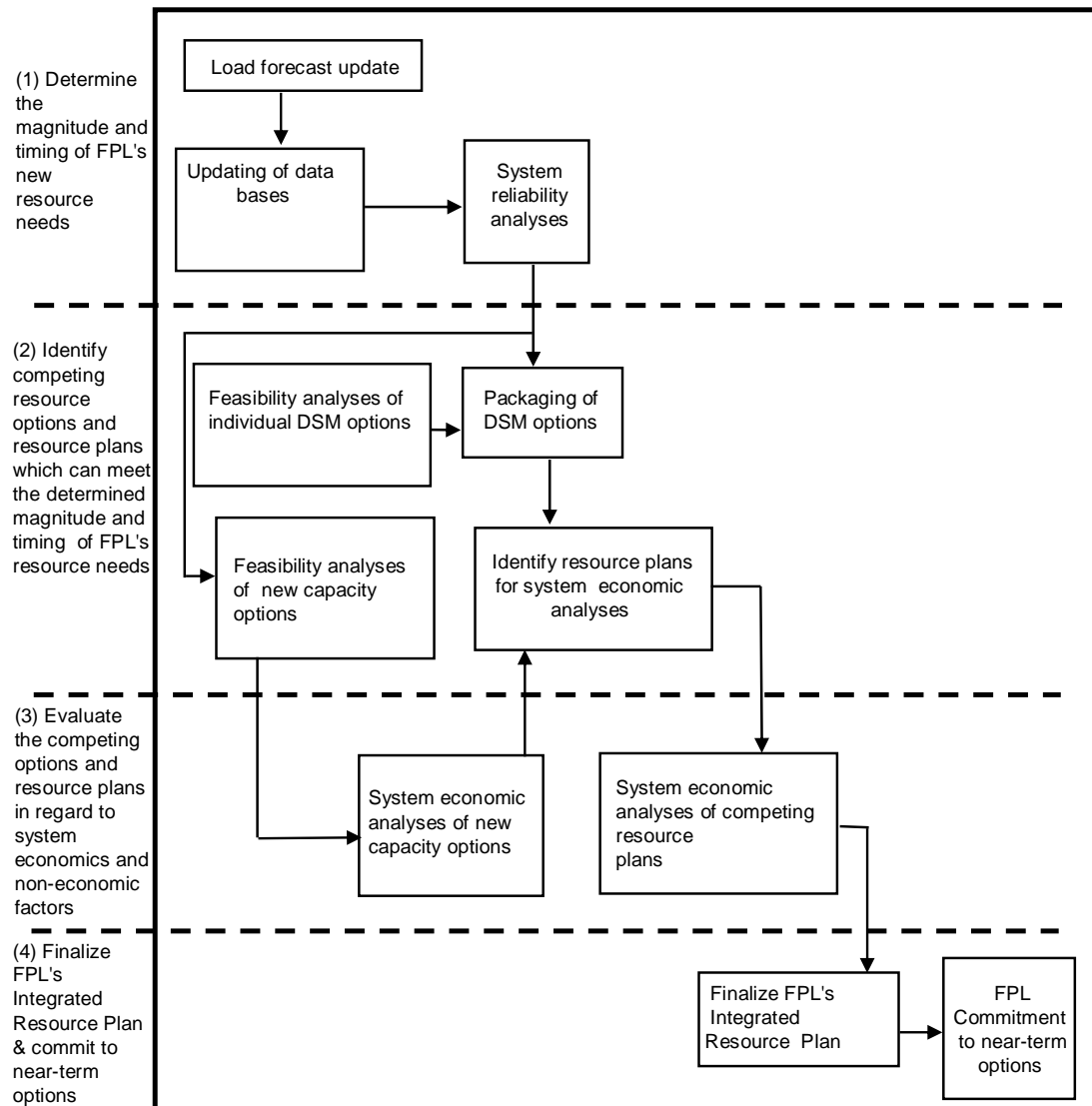

Figure III.A.1: Overview of FPL's IRP Process

Step 1: Determine the Magnitude and Timing of FPL's New Resource Needs:

The first of the four resource planning steps, determining the magnitude and timing of FPL's resource needs, is essentially a determination of the amount of capacity or megawatts (MW) of load reduction, new capacity additions, or a combination of both load reduction and new capacity additions that are needed to maintain system reliability. Also determined in this step is when the MW additions are needed to meet FPL's reliability criteria. This step is often referred to as a reliability assessment, or resource adequacy, analysis for the utility system.

Step 1 typically starts with an updated load forecast. Several databases are also updated in this first fundamental step, not only with the new information regarding forecasted loads, but also with other information that is used in many of the fundamental steps in resource planning. Examples of this new information include, but are not limited to: delivered fuel price projections, current financial and economic assumptions, and power plant capability and operating assumptions. FPL also includes key assumptions regarding three specific resource areas: (1) near-term construction capacity additions, (2) firm capacity power purchases, and (3) DSM implementation.

The first of these assumptions is based on new generating capacity additions that have been approved by the Florida Public Service Commission (FPSC) through Determination of Need proceedings that evaluated both the need for, and the cost-effectiveness of, each of the new capacity additions. These generating capacity additions have also either received the necessary Site Certification approvals from either the Secretary of the Florida Department of Environmental Protection (FDEP) or the Governor and Cabinet (acting as the Siting Board), or these approvals have been applied for. (There is also work in progress to obtain the necessary federal and state licenses, permits, and approvals for construction and operation of two new nuclear units whose earliest practical deployment dates continue to be outside of the 2012 – 2021 reporting period of this Site Plan.)

Several new generating unit additions will occur in the 2012 – 2021 reporting time frame of this document. These generating unit additions include:

- Two existing generating plant sites, each featuring two older fossil fuel-fired steam generating units, are currently in the process of being modernized by removing the existing generating units and replacing them with one new, highly efficient combined

cycle (CC) unit. The new CC plant at FPL's Cape Canaveral site is projected to be placed in-service in mid-2013. This new CC unit is projected to have a peak Summer output of 1,210 MW and will be called the Cape Canaveral Next Generation Clean Energy Center (CCEC). The new CC unit at FPL's Riviera site is projected to be placed in-service in mid-2014 and it is expected to have a peak Summer output of 1,212 MW. This new plant will be called the Riviera Beach Next Generation Clean Energy Center (RBEC). These modernizations were approved by the FPSC in September 2008. The site certification application for Cape Canaveral was granted in October 2009. The site certification application for Riviera Beach was granted in November 2009.

- Similar to the two modernization projects mentioned above, the four existing steam units at the Port Everglades site will be removed and replaced with a new highly efficient CC unit. This unit, called the Port Everglades Next Generation Clean Energy Center (PEEC), is projected to be in-service in mid-2016 and is projected to have a peak Summer output of 1,277 MW. The FPSC voted to approve this modernization project on March 27, 2012. The site certification process is underway.
- FPL will be adding approximately 490 MW of generating capacity at its existing nuclear power plants at the Turkey Point and St. Lucie sites. 31 MW of this increased capacity has already been added at St. Lucie Unit 2 and this additional nuclear capacity is already benefiting FPL's customers. The remaining increased capacity is scheduled to come in-service in the 2012 – 2013 time period. These capacity uprates were approved by the FPSC in January 2008. The Final Order for the Site Certification was issued in September 2008 for the St. Lucie uprates and in October 2008 for the Turkey Point uprates.
- In the fourth quarter of 2011, FPL started upgrading the 7FA combustion turbines (CT) that are components of several of its CC units. These upgrades will economically benefit FPL's customers by increasing the MW output of these CC units by approximately 228 MW (Summer peak value) in total. As reflected in Schedule 1, 26 MW of the increased capacity from these CT upgrades is already in service at Martin 8. The remaining upgrades are projected to be completed during the 2012 through 2015 time period.

These new generating units and generating capacity additions were selected for a variety of reasons including cost-effectiveness, significant system fuel savings, fuel diversity, mitigation of regional generation/load imbalances, and significant system emission reductions, including greenhouse gas emission reductions.

The second of these assumptions involves firm capacity power purchases. FPL's current projection of firm capacity purchases has changed from the projection in the 2011 Site Plan. FPL has three additional short-term purchases for the year 2012 only. These purchases consist of a 125 MW agreement with TECO and two purchases totaling 305 MW from CT facilities in DeSoto County. FPL's current projection also includes an additional 70 MW from the Palm Beach Solid Waste Authority (SWA) starting in year 2016. However, the total projected incremental capacity from Palm Beach SWA has decreased by 35 MW compared to the 2011 Site Plan projection. Also, FPL now projects that its purchase agreement with Jacksonville Electric Authority (JEA) for St. Johns Regional Power Park (SJRPP)-based capacity and energy will allow FPL to continue to receive purchased capacity and energy until the Spring of 2017. At that time, FPL projects that Internal Revenue Service (IRS) regulations regarding the amount of energy that FPL can receive will result in the suspension of any further capacity and energy by FPL.⁵

In total, the projected firm capacity purchases are from a combination of utility and independent power producers. Details, including the annual total capacity values for these purchases, are presented in Chapter I in Tables I.B.1 and I.B.2. These purchased capacity amounts were incorporated in FPL's resource planning work.

The third of these assumptions involves a projection of the amount of additional DSM that is anticipated to be implemented annually over the ten-year period. Since 1994, FPL's resource planning work has assumed that, at a minimum, the DSM MW called for in FPL's approved DSM Plan will be achieved. The resource plan presented in FPL's 2012 Site Plan fully accounts for the DSM Plan direction provided by the FPSC in 2011.

These key assumptions, plus the other updated information described above, are then applied in the first fundamental step: the determination of the magnitude and the timing of FPL's future resource needs. This determination is accomplished by system reliability analyses which for FPL are currently based on dual planning criteria of a minimum peak period reserve margin of 20% (FPL applies this to both Summer and Winter peaks) and a maximum loss-of-load probability (LOLP) of 0.1 day per year. Both of these criteria are commonly used throughout the utility industry.

⁵ FPL's projected suspension date for the SJRPP purchase is based on a system reliability perspective; i.e., the earliest projected date at which the suspension of capacity and energy could occur.

Historically, two types of methodologies, deterministic and probabilistic, have been utilized in system reliability analysis. The calculation of excess firm capacity at the annual system peaks (reserve margin) is the most common method, and this relatively simple deterministic calculation can be performed on a spreadsheet. It provides an indication of the adequacy of a generating system's capacity resources compared to its load during peak periods. However, deterministic methods do not take into account probabilistic-related elements such as the impact of individual unit failures. For example: two 50 MW units which can be counted on to run 90% of the time are more valuable in regard to utility system reliability than is one 100 MW unit which can also be counted on to run 90% of the time. Probabilistic methods also recognize the value of being part of an interconnected system with access to multiple capacity sources.

For this reason, probabilistic methodologies have been used to provide an additional perspective on the reliability of a generating system. There are a number of probabilistic methods that are being used to perform system reliability analyses. Among the most widely used is loss-of-load probability (LOLP) which FPL utilizes. Simply stated, LOLP is an index of how well a generating system may be able to meet its demand (i.e., a measure of how often load may exceed available resources). In contrast to reserve margin, the calculation of LOLP looks at the daily peak demands for each year, while taking into consideration such probabilistic events as the unavailability of individual generators due to scheduled maintenance or forced outages.

LOLP is expressed in units of the "number of times per year" that the system demand could not be served. The standard for LOLP accepted throughout the industry is a maximum of 0.1 day per year. This analysis requires a more complicated calculation methodology than does the reserve margin analysis. LOLP analyses are typically carried out using computer software models such as the Tie Line Assistance and Generation Reliability (TIGER) program used by FPL.

The result of the first fundamental step of resource planning is a projection of how many new MW of resources are needed to meet both reserve margin and LOLP criteria, and thus maintain system reliability, and when the MW are needed. Information regarding the timing and magnitude of these resource needs is then used in the second fundamental step: identifying resource options and resource plans that can meet the determined magnitude and timing of FPL's resource needs.

Step 2: Identify Resource Options and Plans That Can Meet the Determined Magnitude and Timing of FPL's Resource Needs:

The initial activities associated with this second fundamental step of resource planning generally proceed concurrently with the activities associated with Step 1. During Step 2, preliminary economic screening analyses of new capacity options that are very similar in regard to certain key characteristics may be conducted to determine which new capacity options appear to be the most competitive on FPL's system. This preliminary analysis work can also help identify capacity size (MW) values, projected construction/permitting schedules, and operating parameters and costs. Similarly, preliminary economic screening analyses of new DSM options and/or continued growth in existing DSM options are often conducted.

FPL typically utilizes the P-MArea production cost model and a Fixed Cost Spreadsheet, and/or the Strategist model, as well as spreadsheet analyses, to perform the preliminary economic screening of generation resource options. For the preliminary economic screening analyses of DSM resource options, FPL typically uses its DSM cost-effectiveness model which is an FPL spreadsheet model utilizing the FPSC's approved methodology for performing preliminary cost-effectiveness screening of individual DSM measures and programs. FPL also utilizes its non-linear programming model for analyzing the potential for lowering system peak loads through additional load management/demand response capability. Then FPL typically utilizes its linear programming model to develop DSM portfolios that are subsequently used in developing resource plans for final system analyses of DSM-based resource plans.

The individual new resource options emerging from these preliminary economic screening analyses are then typically "packaged" into different resource plans which are designed to meet the system reliability criteria. In other words, resource plans are created by combining individual resource options so that the timing and magnitude of FPL's projected new resource needs are met. The creation of these competing resource plans is typically carried out using spreadsheet and/or dynamic programming techniques.

At the conclusion of the second fundamental resource planning step, a number of different combinations of new resource options (i.e., resource plans) of a magnitude and timing necessary to meet FPL's resource needs are identified.

Step 3: Evaluate the Competing Options and Resource Plans in Regard to System Economics and Non-Economic Factors:

At the completion of fundamental steps 1 & 2, the most viable new resource options have been identified, and these resource options have been combined into a number of resource plans which meet the magnitude and timing of FPL's resource needs. The stage is set for evaluating these resource options and resource plans in final, or system, economic analyses that attempt to account for all of the impacts to the FPL system from the competing resource options/resource plans. (These system impacts are typically not accounted for in preliminary economic screening analyses.) In FPL's 2011 and early 2012 resource planning work, once the resource plans were developed, FPL utilized the P-MArea production cost model and a Fixed Cost Spreadsheet, and/or the Strategist model, to perform the system economic analyses.

The basic economic analyses of the competing resource plans focus on total system economics. The standard basis for comparing the economics of competing resource plans is their relative impact on FPL's electricity rate levels, with the objective generally being to minimize FPL's projected levelized system average electric rate (i.e., a Rate Impact Measure or RIM methodology). In cases in which the DSM contribution was assumed as a given and the only competing options were new generating units and/or purchase options, comparisons of competing resource plans' impacts on electricity rates and on system revenue requirements will yield identical outcomes in regard to the relative rankings of the resource options being evaluated. Consequently, the competing options and plans in such cases were evaluated on a cumulative present value revenue requirement (CPVRR) basis.

Other factors are also included in FPL's evaluation of resource options and resource plans. While these factors may have an economic component or impact, they are often discussed in quantitative, but non-economic terms, such as percentages, tons, etc. rather than in terms of dollars. These factors are often referred to by FPL as "system concerns" that include (but are not necessarily limited to) maintaining/enhancing fuel diversity in the FPL system, system emission levels, and maintaining a regional balance between load and generating capacity, particularly in the Southeastern Florida counties of Miami-Dade and Broward. In conducting the evaluations needed to determine which resource options and resource plans are best for FPL's system, the non-economic evaluations are conducted with an eye to whether the system concern is positively or negatively impacted by a given resource option or resource plan.

Step 4: Finalizing FPL's Current Resource Plan

The results of the previous three fundamental steps are typically used to develop the current resource plan. This plan is presented in the following section.

III.B Projected Incremental Resource Additions/Changes

FPL's projected incremental generation capacity additions/changes for 2012 through 2021 are depicted in Table III.B.1. These capacity additions/changes result from a variety of actions that primarily consist of: (i) changes to existing units (which are frequently achieved as a result of plant component replacements during major overhauls), (ii) increases in generating capacity at FPL's four existing nuclear units, (iii) the temporary return of certain generating units from Inactive Reserve status to active service, then returning these units to Inactive Reserve status, (iv) changes in the amounts of purchased power being delivered under existing contracts as per the contract schedules or by entering into new purchase contracts, (v) the modernizations of FPL's existing Cape Canaveral, Riviera, and Port Everglades sites by the removal of the steam generating units that were previously, or are currently, on the sites and the addition of one new, very fuel-efficient CC generating unit at each site, and (vi) upgrades to the CTs at a number of existing combined cycle plants.

Although the DSM additions that are consistent with the FPSC's directions regarding FPL's DSM Plan are not explicitly presented in this table, these DSM additions have been fully accounted for in all of FPL's resource planning work reflected in this document. The DSM Plan projects annual DSM additions through 2019. For planning purposes, FPL currently projects an additional 100 MW (Summer) of DSM per year for the subsequent two years (2020 and 2021) addressed in this document. In addition, the projected MW reductions from these DSM additions are reflected in the projected reserve margin values shown in the table below and in Schedules 7.1 and 7.2 presented later in this chapter. (Subsequent analyses will ultimately determine the actual levels of DSM that should be implemented in these later years.)

Table III.B.1: Projected Capacity Changes for FPL

Projected Capacity Changes			
Year	Projected Capacity Changes	Net Capacity Changes (MW)	
		Winter⁽¹⁾	Summer⁽²⁾
2012	Sanford Unit 5 CT Upgrade	---	19
	St. Lucie Unit 1 Uprate - Outage ⁽⁵⁾	(853)	---
	St. Lucie Unit 1 Uprates - Completed	---	129
	Turkey Point Unit 3 Uprates - Completed	---	123
	St. Lucie Unit 2 Uprate - Outage ⁽⁵⁾	---	(745)
	Changes to Existing Purchases ⁽³⁾	375	470
	Scherer Unit 4	---	(30)
	Manatee Unit 2	---	(3)
	Inactive Reserve Units (PE Units 3 & 4) -return to active status ⁽⁷⁾	765	761
	Manatee Unit 2 ESP - Outage ⁽⁶⁾	(822)	---
2013	Cape Canaveral Next Generation Clean Energy Center ⁽⁴⁾	---	1,210
	Changes to Existing Purchases ⁽³⁾	(555)	(430)
	Manatee Unit 2	(3)	---
	Sanford Unit 5 CT Upgrade	19	9
	Martin Unit 8 CT Upgrade	10	10
	Sanford Unit 4 CT Upgrade	22	31
	Scherer Unit 4	(28)	---
	St. Lucie Unit 1 Uprates - Completed	129	---
	St. Lucie Unit 2 Uprates - Completed	84	84
	Turkey Point Unit 3 Uprates - Completed	123	---
	Turkey Point Unit 4 Uprates - Completed	---	123
	Turkey Point Unit 4 Uprates - Outage ⁽⁵⁾	(717)	---
	Inactive Reserve Unit (PE Units 3 & 4) - return to inactive status ⁽⁷⁾	(765)	(761)
	Manatee Unit 1 ESP - Outage ⁽⁶⁾	(822)	---
	Martin Unit 1 ESP - Outage ⁽⁶⁾	--	(826)
2014	Cape Canaveral Next Generation Clean Energy Center ⁽⁴⁾	1,355	---
	Sanford Unit 4 CT Upgrade	16	---
	Sanford Unit 5 CT Upgrade	19	10
	Manatee Unit 3 CT Upgrade	---	19
	Turkey Point Unit 5 CT Upgrade	---	33
	Turkey Point Unit 4 Uprates - Completed	123	---
	Martin Unit 1 ESP - Outage ⁽⁶⁾	(832)	---
	Martin Unit 2 ESP - Outage ⁽⁶⁾	---	(826)
	Riviera Beach Next Generation Clean Energy Center ⁽⁴⁾	---	1,212
2015	Manatee Unit 3 CT Upgrade	39	20
	Turkey Point Unit 5 CT Upgrade	33	---
	Ft. Myers Unit 2 CT Upgrade	---	51
	Riviera Beach Next Generation Clean Energy Center ⁽⁴⁾	1,344	---
2016	Changes to Existing Purchases ⁽³⁾	(858)	(858)
	Ft. Myers Unit 2 CT Upgrade	51	---
	Turkey Point Unit 1 operation changed to synchronous condenser	---	(396)
	Port Everglades Next Generation Clean Energy Center ⁽⁴⁾	---	1,277
2017	Changes to Existing Purchases ⁽³⁾	---	(375)
	Turkey Point Unit 1 operation changed to synchronous condenser	(398)	---
	Port Everglades Next Generation Clean Energy Center ⁽⁴⁾	1,429	---
2018	Changes to Existing Purchases ⁽³⁾	(383)	---
2019	---	---	---
2020	---	---	---
2021	Short Term Purchase	---	250

(1) Winter values are forecasted values for January of the year shown.
(2) Summer values are forecasted values for August of the year shown.
(3) These are firm capacity and energy contracts with QF, utilities, and other entities. See Table I.B.1 and Table I.B.2 for more details.
(4) All new unit additions are scheduled to be in-service in June of the year shown. All additions assumed to start in June are included in the Summer reserve margin calculation starting in that year and in the Winter reserve margin calculation starting with the next year.
(5) Outages for uprate work.
(6) Outages for ESP work.
(7) A number of existing FPL power plants have been removed from service and placed on Inactive Reserve status. See Chapter III for a discussion of the units on Inactive Reserves.

III.C Discussion of the Projected Resource Plan and Issues Impacting FPL's Resource Planning Work

As indicated in the Executive Summary, FPL's resource planning efforts in 2011 and early 2012 were influenced by a number of factors. Furthermore, these factors are expected to continue to influence FPL's resource planning work for the foreseeable future. There are 5 such factors that are of primary importance:

- 1) Maintaining/enhancing fuel diversity in the FPL system;
- 2) Maintaining a balance between load and generating capacity in Southeastern Florida, particularly in Miami-Dade and Broward Counties;
- 3) Growing dependence upon DSM resources to maintain FPL system reliability;
- 4) Securing additional natural gas (and doing so in a manner that enhances the reliability of the natural gas supply system); and,
- 5) Possible establishment of "Clean Energy Standards" or another mechanism to promote large scale utilization of renewable energy.

These 5 factors, and their various impacts on FPL's resource planning efforts including the current resource plan that is presented in this Site Plan, are briefly discussed below.

1. Maintaining/Enhancing System Fuel Diversity;

FPL is currently dependent upon using natural gas to generate more than half of the electricity it delivers to its customers. In the future, the percentage of FPL's electricity that is generated by natural gas is projected to increase. Therefore, FPL is continually seeking opportunities to maintain and enhance the fuel diversity of its system.

In 2007, following express direction by the Commission to do so, FPL sought approval from the FPSC to add two new advanced technology coal units to its system. These two new units would have been placed in-service in 2013 and 2014. However, in part due to concerns over potential greenhouse gas emission legislation/regulation, FPL was unable to obtain approval for these units. Several other factors are currently unfavorable to new coal units compared to new CC units. The first of these factors is a significant reduction in the fuel cost difference between coal and natural gas compared to the fuel cost difference projected in 2007 that favored coal; i.e., the projected cost advantage of coal versus natural gas has been

significantly reduced. Second is the continuation of significantly higher capital cost for coal units compared to capital cost for CC units. Third is the increased fuel efficiency of new CC units compared to projected CC unit efficiencies in 2007. Fourth are the stricter non-greenhouse gas environmental regulations that are more unfavorable to new coal units than to new CC units. Consequently, FPL does not believe that new advanced technology coal units are currently economically, politically, or environmentally viable fuel diversity enhancement options in Florida.

Therefore, FPL has turned its attention to nuclear energy and renewable energy to enhance its fuel diversity and to using natural gas more efficiently. In regard to nuclear energy, FPL previously obtained approval to increase capacity at each of its four existing nuclear units. In total, these capacity uprates will add approximately 490 MW of nuclear capacity and energy for FPL's customers. 31 MW of increased nuclear capacity from the uprates have been achieved at St. Lucie Unit 2 and this increased nuclear capacity is already benefiting FPL's customers. The remaining increased nuclear capacity from the uprates project is scheduled to come on-line during 2012 through early 2013. In 2008, the FPSC approved the need for these uprates and authorized FPL to recover uprates-related expenditures that are approved as a result of annual nuclear cost recovery filings.

FPL is continuing its work to obtain all of the licenses, permits, and approvals that would be necessary to construct and operate two new nuclear units at its Turkey Point site in the future. These licenses, permits, and approvals will provide FPL with the opportunity to construct these nuclear units at Turkey Point for a commercial operations date expected to be up to 20 years from the time the licenses and permits are granted, and then to operate the units for at least 40 years thereafter. The earliest practical deployment dates for the two new units continue to be beyond the 10-year reporting period for this Site Plan. Therefore, these units are not shown in this document.

FPL also has been involved in activities to investigate adding or maintaining renewable resources as a part of its generation supply. One of these activities is a variety of discussions with the owners of existing facilities aimed at maintaining or extending current agreements that are scheduled to end during the ten-year reporting period of this document. FPL also sought and received approval from the FPSC in 2008 to add 110 MW through three new FPL-owned solar facilities: one solar thermal facility and two photovoltaic (PV) facilities. One 25 MW PV facility began commercial

operation in 2009. The remaining two solar facilities, a 10 MW PV facility and a 75 MW solar thermal steam generating facility, began commercial operation in 2010. The addition of these renewable energy facilities was made possible due to enabling legislation from the Florida Legislature in 2008. FPL remains strongly supportive of Federal and/or State legislation that enables electric utilities to add renewable energy resources and authorize the utilities to recover appropriate costs for these resources.

In regard to using natural gas more efficiently, FPL received approvals in 2008 from the FPSC to modernize the existing Cape Canaveral and Riviera plant sites with new, highly efficient CC units that replace the former steam generating units on each of those sites. The modernizations of Cape Canaveral and Riviera are currently underway and are projected to go in-service on time in mid-2013 and mid-2014, respectively. On March 27, 2012, FPL received FPSC approval to proceed with a similar modernization project at the Port Everglades site which is scheduled for completion in mid-2016. The modernization of Port Everglades will retain the capability of receiving water-borne delivery of oil as a backup fuel.

In the future, FPL will continue to identify and evaluate alternatives that may maintain or enhance system fuel diversity. Moreover, FPL is also maintaining the ability to utilize fuel oil at existing units that have that capability. FPL is in the process of installing electrostatic precipitators (ESPs) at its four 800 MW steam generating units at the Martin and Manatee sites which will enable FPL to retain the ability to burn oil, as needed, at these sites while retaining the flexibility to use natural gas when economically attractive. Furthermore, FPL continues to evaluate the potential for greater diversity in the delivery of natural gas through a new, third natural gas pipeline. A third pipeline would result in a more reliable, and more economic and more diverse, natural gas supply for FPL's customers and the state of Florida.

2. Maintaining a Balance Between Load and Generation in Southeastern Florida:

In recent years, an imbalance was projected to develop between regionally installed generation and regional peak load in Southeastern Florida. With such an imbalance, a significant amount of energy required in the Southeastern Florida region during peak periods would need to be provided either by operating less efficient generating units located in Southeastern Florida out of economic dispatch, or by importing the energy through the transmission system from plants located outside the region. FPL's prior planning work concluded that either additional installed generating capacity in

this region, or additional installed transmission capacity capable of delivering more electricity from outside the region, would be required to address this imbalance.

Partly because of the lower transmission-related costs resulting from their location, four recent capacity addition decisions (Turkey Point Unit 5 and WCEC Units 1, 2, & 3) were determined to be the most cost-effective options to meet FPL's capacity needs in the near-term. In addition, FPL will be adding increased capacity at FPL's existing two nuclear units at Turkey Point in 2012 and 2013. The recently approved Port Everglades modernization project scheduled for completion in 2016 will also significantly aid in mitigating this imbalance. Adding this additional generation capacity contributes to addressing the imbalance between generation and load in Southeastern Florida for the approximately the remainder of this decade.

The planned two new nuclear units at FPL's Turkey Point site will also address the imbalance issue for an additional period of time. Due to steadily increasing load in the Southeastern region, the Southeastern Florida imbalance issue will remain an important consideration in FPL's on-going resource planning work in future years.

3. Growing Dependence Upon DSM Resources to Maintain System Reliability:

In late 2009, the FPSC imposed significantly higher DSM Goals than had been deemed appropriate in previous DSM Goals dockets. The FPSC's 2011 DSM Plan decision lowered these required levels of DSM, but only by a relatively small amount.

As a result, FPL is projected to become increasingly dependent upon DSM resources, instead of generation resources, to maintain system reliability. Schedules 7.3 and 7.4 demonstrate this point. These schedules are presented in the back portion of this chapter. Both of these schedules use Schedule 7.1, which presents FPL's projected Summer reserve margins, as a starting point.

In Schedule 7.3, Column (14), FPL projects what a "generation-only" reserve margin would be for each year in the 10-year reporting period, after accounting for all approved generation additions through 2016, by making two changes in Schedule 7.1. First, the projected DSM values in Column (8) have been zeroed out to remove the projected contribution from DSM. Second, the projected addition of a 250 MW short-term power purchase in 2021 has been removed. These two changes result in

a projection of reserve margins that are based solely on generation resources that currently exist or which have been approved by the FPSC.

The result is a projected generation-only reserve margin in the range of approximately 16% to 13% through 2016, but which decreases steadily thereafter to 4.5% by 2021.

In Schedule 7.4, the projected addition of the projected 2021 PPA has been added back in as reflected by the values in Column (1). The projected generation-only reserve margin for the year 2021 now increases, but only to 5.5%. Although marginally higher than the 4.5% value for 2021 projected in Schedule 7.3, the 5.5% value is also considerably lower than the 16% to 13% range for the years 2012 through 2016. In the years from 2017 through 2020, the projected generation-only reserve margin steadily decreases to less than 6.5% by 2020 and under 6% by 2021.

Therefore, FPL's projected system reserves, already dependent to a significant degree upon DSM resources, are becoming increasingly more dependent upon DSM. Stated another way, the FPL system's ability to continue to provide reliable electricity service to FPL's customers is becoming increasingly dependent upon DSM. FPL currently believes that generation-only reserves at these projected low levels may not be adequate, and FPL will continue to evaluate the appropriateness of a minimum generation-only requirement as part of its on-going resource planning work.

4. Securing Additional Natural Gas:

The recent trend of increasing reliance upon natural gas to produce electricity for FPL's customers is projected to continue due to FPL's growing load. The addition of the highly fuel-efficient Cape Canaveral, Riviera, and Port Everglades modernizations will serve to reduce the growth in natural gas use from what it otherwise might have been due to the high fuel-efficiency levels of these new CC units, but these efficiencies do not offset the effects of FPL's growing load. Therefore, FPL will need to secure more natural gas supply and more gas transportation capacity. The issue is how to secure these additional natural gas resources in a manner that is economical for FPL's customers and which maintains and/or enhances the reliability of natural gas supply and deliverability to FPL's generating units.

FPL has historically purchased the gas transportation capacity required for new natural gas supply from two existing natural gas pipeline companies. As more natural gas is delivered through two pipelines entering Florida, the impact of a supply disruption on either pipeline becomes more problematic. Therefore, FPL sought approval in 2009 from the FPSC for the construction of a new, third natural gas pipeline into Florida capable of serving future gas-fired generation needs for FPL and others in the state. Such a third pipeline was projected to have benefits for FPL and its customers by increasing the diversity of FPL's fuel supply sources, increasing the physical reliability of the pipeline delivery system, and enhancing competition among pipelines. However, the application for an FPL-owned pipeline was denied by the FPSC in 2009. FPL is continuing to evaluate alternatives to increase the diversity of natural gas deliveries in order to meet the future gas requirements of FPL and the State of Florida.

5. Possible Establishment of "Clean Energy Standards":

At the time this document is being prepared, neither the United States nor the State of Florida has established a "Clean Energy Standard" which would require that a certain amount of energy be supplied by "clean" energy sources. A similar "Renewable Portfolio Standard" proposal was prepared by the FPSC and sent to the Florida Legislature for their consideration, including an option to change the standard to a Clean Energy Standard, during the 2009 legislative session. However, no such legislation was enacted during the 2009 session or in subsequent legislative sessions. Such legislation, or other legislative initiatives regarding clean energy contributions, may occur in the future. If such legislation is enacted in a future year, FPL will then determine what steps need to be taken to comply with the legislation. Such steps would then be discussed in FPL's Site Plan in the year following the enactment of such legislation.

III.D Demand Side Management (DSM)

During 2011 and early 2012, FPL offered the following DSM programs to its customers:

Residential DSM Programs

- 1. Residential Building Envelope:** Offers rebates to residential customers to install energy-efficient reflective roof and ceiling insulation measures.

2. **Duct System Testing and Repair:** Provides reduced cost duct system testing to identify leaks in air conditioning duct systems, and encourages the repair of those leaks by qualified contractors. Rebates are offered for duct system repair.
3. **Residential Air Conditioning:** Offers rebates to customers to purchase higher efficiency air conditioning and heating equipment. The program includes additional rebates for plenum repair measure and air handler units with electronically commutated motors.
4. **Residential Load Management (On Call Program):** Offers load control of major appliances/household equipment in exchange for monthly electric bill credits. Direct load control equipment is installed on selected customer end-use equipment allowing FPL to control these customer loads as needed. Qualifying equipment includes central electric air conditioners, central electric heaters, conventional electric water heaters, and swimming pool pumps.
5. **Residential New Construction (BuildSmart):** Encourages the design and construction of energy-efficient homes by offering education to contractors on energy efficiency measures, and providing construction design reviews and home inspections.
6. **Residential Low Income Weatherization:** Combines energy audits and incentives to encourage low income housing administrators to retrofit homes with energy efficiency measures. The housing authorities include: weatherization agency providers (WAPS), non-weatherization agency providers (non-WAPS), and other providers approved by FPL. The rebates are used by these providers to leverage their funds to increase the overall energy efficiency of the homes they are retrofitting. FPL offers rebates for HVAC maintenance, reduced air infiltration measures, and room air conditioning replacement.
7. **Residential Conservation Service:** Offers a walk-through energy audit, a computer-generated Class A audit, and a customer-assisted energy audit. For customer-assisted energy audits, mail-in, phone, and Internet audit options are available. (Note that FPL does not count demand and energy savings from this program towards its DSM Goals.)

Business DSM Programs

1. **Business Heating, Ventilating, and Air Conditioning (HVAC):** Offers business customers financial rebates to upgrade to higher efficiency HVAC equipment that

exceed the minimum efficiencies mandated by the U.S. Department of Energy. The current FPL program includes rebates for: 1) thermal storage; 2) chillers; 3) energy recovery ventilator units; 4) direct expansion (DX) units and efficient air conditioning room units; 5) demand control ventilation systems including kitchen hood control; and 6) electrically commutated motors for air conditioning systems.

2. **Business Efficient Lighting:** Offers business customers financial rebates to install high efficiency lighting measures at the time of replacement. FPL's program addresses linear fluorescent, plus other, efficient lighting technologies.
3. **Business Building Envelope:** Offers financial rebates to customers to install high efficiency building envelope measures such as roof/ceiling insulation, reflective roof coatings, and window treatments.
4. **Business Custom Incentive:** Serves as a "catch-all" program for customer-specific cost-effective efficiency measures which are not included in other FPL programs. DSM measures must reduce or shift at least 25 kW during peak hours, have verifiable demand and energy savings, and pass FPL's preliminary cost-effectiveness screening testing.
5. **Business On Call:** Offers load control of central air conditioning units to both small non-demand-billed, and medium demand-billed, customers in exchange for monthly electric bill credits.
6. **Commercial Industrial Demand Reduction (CDR):** Reduces peak demand by allowing the direct control of customer loads of 200 kW or greater during periods of extreme demand or capacity shortages. Participants contract for a firm demand level which may not be exceeded during load control periods. In return, participants receive a monthly credit. Participants must provide a 5-year termination notice to discontinue service under this program.
7. **Business Energy Evaluation:** Offers free standard level energy evaluations on-site and on-line. More detailed evaluations are available through this audit program with costs shared between FPL and the participating customer. Participation in FPL's other business DSM programs is promoted through this program. (Note that FPL does not count demand or energy savings from this program towards its DSM Goals.)
8. **Commercial/Industrial Load Control:** Reduces peak demand by controlling customer loads of 200 kW or greater during periods of extreme demand or capacity

shortages in exchange for monthly electric bill credits. (This program has been closed to new participants since the year 2000).

9. **Business Water Heating:** Encourages the installation of energy-efficient heat recovery units or heat pump water heaters.
10. **Business Refrigeration:** Encourages the installation of controls and equipment to reduce the usage of electric strip heat for defrosting purposes.
11. **Cogeneration and Small Power Production:** Facilitates FPL compliance with all regulatory requirements concerning qualifying facilities and small power producers. One role of the program is to assist customers in the evaluation of potential cogeneration projects, including self-generation. (Note that FPL does not count demand or energy savings from this program towards its DSM Goals.)

DSM Research and Development:

FPL's Conservation Research and Development (CRD) Program is an umbrella research project under which new DSM technologies are analyzed. Several FPL DSM programs have emerged from the CRD program including the business Building Envelope, Business On Call, and Residential New Construction programs. The program has also resulted in the addition of cost-effective measures to existing programs, such as the proposed inclusion of Energy Recovery Ventilators to the Business HVAC Program. FPL operates the CRD program based on DSM Plan approval, or for 6 years, whichever occurs first, with a spending cap as approved in the most current DSM Plan.

In summary regarding FPL's DSM efforts, FPL has sought out and implemented cost-effective DSM programs since 1978. These programs include both conservation initiatives and load management. FPL's DSM efforts through 2011 have resulted in a cumulative Summer peak reduction of approximately 4,513 MW (Summer) at the generator and an estimated cumulative energy saving of approximately 59,890 Gigawatt Hour (GWh) at the generator. After accounting for reserve margin requirements, FPL's DSM efforts through 2011 have eliminated the need to construct the equivalent of more than 13 new 400 MW generating units.

The FPSC in late 2009 imposed significantly higher DSM Goals for FPL for 2010 – 2019 than were deemed appropriate in prior DSM Goals dockets. The DSM Goals recently imposed by the FPSC have three components: Summer MW reductions, Winter MW reductions, and GWh reductions. The Summer MW component, and to a much lesser

degree the Winter MW reduction component, impacts FPL's need for future resources such as those discussed in this document. The GWh reduction component has no impact on FPL's need for future resources.

In 2011, based on concerns over the projected higher electric rates that would occur if a new DSM Plan to meet the new DSM Goals were implemented, the FPSC determined in the DSM Plan docket that FPL should continue to implement the specific DSM programs, that FPL was implementing at that time (FPSC Order PSC-11-0590-FOF-EG). The projected demand reduction impact of these DSM programs from 2012 through 2019 (plus an assumed additional 100 MW per calendar year for 2020 and 2021) is presented below in Table III.D.1. (Subsequent analyses will ultimately determine the actual levels of DSM that should be added in these later years.)

Table III.D.1: FPL's Projected DSM Summer MW Reduction for 2012 - 2021
August MW values (at the Generator)

Year	Cumulative Summer MW DSM Goals for FPL (at Generator)
2012	136
2013	259
2014	422
2015	553
2016	685
2017	816
2018	947
2019	1079
2020	1188
2021	1288

FPL has consistently been among the leading utilities nationally in DSM achievement. For example, according to the U.S. Department of Energy's 2010 data (the last year for which the DOE data was available at the time this Site Plan is being developed), FPL ranked # 2 nationally in cumulative DSM demand reduction. And, importantly, FPL has achieved these significant DSM accomplishments while seeking to lessen the DSM-based impact on electric rates for all of its customers.

In regard to DSM, FPL's intent is to follow the FPSC's directions regarding DSM implementation and to continue its national leadership role in DSM consistent with efforts

both to continue to lessen the DSM-based impact on electric rates for all of FPL's customers, and to ensure that FPL's system reliability does not become too dependent upon DSM resources.

III.E Transmission Plan

The transmission plan will allow for the reliable delivery of the required capacity and energy to FPL's retail and wholesale customers. The following table presents FPL's proposed future additions of 230 kV bulk transmission lines that must be certified under the Transmission Line Siting Act.

Table III.E.1: List of Proposed Power Lines

(1) Line Ownership	(2) Terminals (To)	(3) Terminals (From)	(4) Line Length CKT. Miles	(5) Commercial In-Service Date (Mo/Yr)	(6) Nominal Voltage (KV)	(7) Capacity (MVA)
FPL	St. Johns ^{1/}	Pringle	25	Dec - 16	230	759
FPL	Manatee ^{2/}	Bob White	30	Dec - 14	230	1195

1/ Final order certifying the corridor was issued on April 21, 2006. This project is to be completed in two phases. Phase I consisted of 4 miles of new 230 kV line (Pringle to Pellicer) and was completed in May-2009. Phase II consists of 21 miles of new 230 kV line (St. Johns to Pellicer) and is scheduled to be completed by Dec-2016.

2/ Final order certifying the corridor was issued on November 6, 2008. This project consists of 30 miles of new 230 kV line (Manatee to Bob White) and is scheduled to be completed by Dec-2014

In addition, there will be transmission facilities needed to connect several of FPL's projected generating capacity additions to the system transmission grid. These transmission facilities (described on the following pages) are for the capacity increases (uprates) at the existing St. Lucie and Turkey Point nuclear sites, and the generating capacity additions with the Cape Canaveral, Riviera Beach and Port Everglades modernizations.

In regard to the existing generating units that have been placed on Inactive Reserve status and/or which will be retired in late 2012, there are no projected impacts to FPL's transmission system from these units.

III.E.1 Transmission Facilities for St. Lucie Units 1 & 2 Capacity Uprates

The work required to address the St. Lucie Units 1 & 2 uprates in 2012 in regard to the FPL grid consists of the following:

I. Substation:

1. At Midway Substation, replace eleven 230 kV disconnect switches, and remove six wave traps. Also upgrade associated jumpers, bus work and equipment connections.
2. At St. Lucie Switchyard, replace eighteen 230 kV disconnect switches and remove six wave traps.
3. Uprate the Unit 1A and 1B main step-up transformers to 635 MVA. Unit 1B main step-up transformer is to be replaced by the uprated spare main step-up transformer. Existing Unit 1B main step-up transformer is to become the new station spare
4. Uprate the spare main step-up transformer to 635 MVA to replace Unit 2A main step-up transformer.
5. Replace the Unit 2A and Unit 2B main step-up transformer with a new one rated at 635 MVA.
6. Add fiber optic relays and other protective equipment.

II. Transmission:

1. Upgrade the three existing St. Lucie-Midway 230 kV lines with spacers between the conductors to achieve a normal (continuous) rating of 2790 Amperes.
2. Replace one existing overhead ground wire on each of the three existing St. Lucie Midway 230 kV line with fiber optic overhead ground wire for protective relay communication.

III.E.2 Transmission Facilities for Turkey Point Units 3 & 4 Capacity Upgrades

The work required to address the Turkey Point Units 3 & 4 upgrades in 2012 for Unit 3 and in 2012-2013 for Unit 4, in regard to the FPL grid consists of the following:

I. Substation:

1. At Turkey Point Switchyard, install two 5-Ohm series phase inductors combined with external shunt capacitors on the southeast and southwest 230 kV operating busses.
2. At Turkey Point Switchyard, replace twelve 230 kV disconnect switches. Also upgrade associated jumpers, bus work and equipment connections.
3. Upgrade the Unit 3 and Unit 4 main step-up transformers to 970 MVA.
4. Replace spare main step-up transformer with 1028 MVA transformer.
5. Add relays and other protective equipment.
6. Replace breaker failure panels at Davis Substation.
7. Replace breaker failure panels at Flagami Substation.

II. Transmission:

1. Upgrade the existing string busses for both Units 3 & 4 between the main step-up transformers and the switchyard with spacers between the conductors.

III.E.3 Transmission Facilities for Cape Canaveral Next Generation Clean Energy Center (Modernization)

The work required to connect the Cape Canaveral Next Generation Clean Energy Center in 2013 to the FPL grid is projected to be as follows:

I. Substation:

1. Build new collector yard containing two collector busses with four breakers to connect the three combustion turbines (CT), and one steam turbine (ST).
2. Construct two string busses to connect the collector busses to Cape Canaveral 230 kV Substation.
3. Add four main step-up transformers (3-370 MVA, 1- 580 MVA), one for each CT, and one for the ST.
4. At Cape Canaveral Switchyard replace eight 230 kV disconnect switches. Also upgrade associated jumpers, bus work and equipment connections.
5. Expand switchyard relay vault and add relays and other protective equipment.

II. Transmission:

1. Relocate the Cape Canaveral-Grissom 115 kV line.

III.E.4 Transmission Facilities for Riviera Beach Next Generation Clean Energy Center (Modernization)

The work required to connect the Riviera Beach Next Generation Clean Energy Center in 2014 to the FPL grid is projected to be as follows:

I. Substation:

1. Expand the Riviera 230 kV Switchyard five breakers to accommodate terminals for one combustion turbine (CT), and one steam turbine (ST).
2. Construct a new 138 kV Riviera Switchyard - five bays, 14 breakers with terminals to connect two CT units and seven 138 kV lines.
3. Add four main step-up transformers (3-370 MVA, 1- 580 MVA), one for each CT, and one for the ST.
4. Add relays and other protective equipment.
5. At Ranch Substation, add a new 230 kV bay 5 and upgrade bay 4 to 3000 Amperes.
6. Breaker replacements:
 - Ranch Substation – Replace one 230 kV breaker
 - Broward Substation – Replace one 230 kV breaker

II. Transmission:

1. Break the Indiantown-Riviera 230 kV and extend each of the line segments south (approx. 4 miles) to connect to the Ranch 230 kV Substation forming Indiantown-Ranch and a Ranch-Riviera 230 kV circuits.
2. Remove Corbett-Ranch #2 230 kV line at Ranch and:
 - a. extend to meet the Cedar-Lauderdale 230 kV line N/S corridor (approx. 10 miles).
3. Break Cedar-Corbett 230 kV (near Ranch Sub in Corbett-Jog section) and:
 - a. Extend Cedar side to Riviera, (approx. 15 miles) creating new Cedar-Riviera 230 kV.
 - b. Extend Corbett side to meet the Cedar-Lauderdale 230 kV N/S corridor (approx. 10 miles).
4. Break Cedar-Lauderdale 230 kV (near 230 corridor running N/S)
 - a. Connect Cedar side to meet 3.b. to create a Cedar to Corbett 230 kV.
 - b. Connect Lauderdale side to meet 2.a. to create a Corbett to Lauderdale 230 kV.
5. Upgrade the existing IBM-Yamato 138 kV line to 1200 Amperes.
6. New underground 138 kV tie line between new Riviera 138 kV Switchyard and 560 MVA, 230/138 kV autotransformer in the expanded Riviera 230 kV Substation.
7. Relocate six existing 138 kV lines from existing Riviera 138 kV Switchyard to new Riviera 138 kV Switchyard.

III.E.5 Transmission Facilities for Port Everglades Next Generation Clean Energy Center (Modernization)

The work required to connect the Port Everglades Next Generation Clean Energy Center in 2016 to the FPL grid is projected to be as follows:

I. Substation:

1. Construct two string busses to connect two combustion turbines (CT) to the Port Everglades 138 kV Substation.
2. Construct two string busses to connect one CT, and one steam turbine (ST) to the Port Everglades 230 kV Substation.
3. Add four main step-up transformers (3-450 MVA, 1- 580 MVA), one for each CT, and one for the ST.
4. Replace ten (10) 138 kV breakers
5. Replace eight (8) 230 kV breakers
6. At Port Everglades Switchyard replace twenty-two 138 kV disconnect switches. Also upgrade associated jumpers, bus work, and equipment connections.
7. Expand switchyard relay vault and add relays and other protective equipment.

II. Transmission:

1. Upgrade of existing transmission facilities:
 - An ampacity upgrade up to 1905 amps on the Port Everglades-Port Everglades Tap 138kV line section.
 - An ampacity upgrade up to 1905 amps on the Port Everglades Tap-Port Everglade Tap 2 138 kV line section.
 - An ampacity upgrade up to 1695 amps on the Port Everglades Tap 1-Dania 138 kV line section.
 - An ampacity upgrade up to 1695 amps on the Dania-Hollywood 138 kV line section.

III.F. Renewable Resources

FPL has been the leading Florida utility in examining ways to effectively utilize renewable energy technologies to serve its customers. FPL has been involved since 1976 in renewable energy research and development and in facilitating the implementation of various renewable energy technologies. For purposes of discussing FPL's renewable energy efforts in this document, those efforts will be placed into five categories.

Two of these categories are Supply-Side Efforts – Power Purchases and Supply-Side Efforts – FPL Facilities. In 2011, the energy (MWh) total output from these renewable energy sources was greater than the energy produced from oil-fired generation. This information is presented in Schedule 11.1 at the end of this chapter.

1) Early Research & Development Efforts:

FPL assisted the Florida Solar Energy Center (FSEC) in the late 1970s in demonstrating the first residential PV system east of the Mississippi. This PV installation at FSEC's Brevard County location was in operation for over 15 years and provided valuable information about PV performance capabilities in Florida on both a daily and annual basis. FPL later installed a second PV system at the FPL Flagami substation in Miami. This 10-kilowatt (kW) system was placed into operation in 1984. (The system was removed in 1990 to make room for substation expansion once PV testing had been completed.)

For a number of years, FPL maintained a thin-film PV test facility located at the FPL Martin Plant Site. This FPL PV test facility was used to test new thin-film PV technologies and to identify design, equipment, or procedure changes necessary to accommodate direct current electricity from PV facilities into the FPL system. Although this testing has ended, the site is now the home for PV capacity which was installed as a result of FPL's "green pricing" efforts.

2) Demand Side & Customer Efforts:

In terms of utilizing renewable energy sources to meet its customers' needs, FPL initiated the first utility-sponsored conservation program in Florida designed to facilitate the implementation of solar technologies by its customers. FPL's Conservation Water Heating Program, first implemented in 1982, offered incentive payments to customers who chose solar water heaters. Before the program ended (due to the fact that it was no longer cost-effective), FPL paid incentives to approximately 48,000 customers who installed solar water heaters.

In the mid-1980s, FPL introduced another renewable energy program, FPL's Passive Home Program. This program was created in order to broadly disseminate information about passive solar building design techniques which are most applicable in Florida's climate. As part of this program, three Florida architectural firms created complete construction blueprints for six passive home designs with the assistance of the FSEC and FPL. These designs and blueprints were available to customers at a low cost. During its existence, this program was popular and received a U.S. Department of Energy award for innovation. The program was eventually phased out due to a revision of the Florida Model Energy Building Code (Code). This revision was brought about in part by FPL's Passive Home Program. The revision incorporated into the Code was one of the most significant passive design techniques highlighted in the program: radiant barrier insulation.

In early 1991, FPL received approval from the FPSC to conduct a research project to evaluate the feasibility of using small PV systems to directly power residential swimming pool pumps. This research project was completed with mixed results. Some of the performance problems identified in the test were deemed to be solvable, particularly when new pools are constructed. However, the high cost of PV, the significant percentage of sites with unacceptable shading, and various customer satisfaction issues remain as significant barriers to wide acceptance and use of this particular solar application.

FPL has since continued to analyze and promote the utilization of PV. These efforts have included PV research, development, and education, as well as development and implementation of the FPL Next Generation Solar Station Program. As part of this program in 2011, FPL contributed 30 kW of PV to schools and educational non-profit organizations within its service area. This initiative also delivers teacher training and curriculum that is tied to the Sunshine Teacher Standards in Florida. Additionally, the program provides teacher grants to promote and fund projects in the classrooms.

In addition, FPL assists customers who are interested in installing PV equipment at their facilities. Consistent with Florida Administrative Code Rule 25-6.065, Interconnection and Net Metering of Customer-Owned Renewable Generation, FPL works with customers to interconnect these customer-owned PV systems. Through December 2011, approximately 1,580 customer systems (predominantly residential) have been interconnected.

As part of its 2009 DSM Goals decision, the FPSC imposed a requirement for Florida's investor-owned utilities to spend up to a set, not-to-exceed amount of money annually to facilitate demand side solar water heater and photovoltaic applications. FPL's not-to-exceed amount of money for these applications is approximately \$15.5 million per year through 2014. In regard to this direction, FPL received approval from the FPSC in 2011 to initiate a solar pilot portfolio that consists of three PV-based programs and three solar water heating-based programs. These programs are currently projected to be offered through 2014. FPL is now evaluating the results from the first year of implementation of these programs.

FPL has also been investigating fuel cell technologies through monitoring of industry trends, discussions with manufacturers, and direct field trials. From 2002 through the end of 2005, FPL conducted field trials and demonstration projects of Proton Exchange Membrane (PEM) fuel cells with the objectives of serving customer end-uses while evaluating the technical performance, reliability, economics, and relative readiness of the PEM technology. The demonstration projects were conducted in partnership with customers and included five locations. The research projects were useful to FPL in identifying specific issues that can occur in field applications and the current commercial viability of this technology. FPL will continue to monitor the progress of these technologies and conduct additional field evaluations as significant developments in fuel cell technologies occur.

3) Supply Side Efforts – Power Purchases:

FPL has also facilitated renewable energy projects (facilities which burn bagasse, waste wood, municipal waste, etc.). Firm capacity and energy, and as-available energy, have been purchased by FPL from these types of facilities. (Please refer to Tables I.B.1, I.B.2, and I.C.1 in Chapter I).

Periodically, FPL invites renewable energy suppliers to provide proposals for renewable power and energy at or below avoided costs in response to FPL's Requests for Proposals (RFPs). FPL issued Renewable RFPs in 2007 and 2008 soliciting proposals to provide firm capacity and energy, and energy only, at or below avoided costs, from renewable generators. FPL also promptly responds to inquiries for information from prospective renewable energy suppliers either by e-mail or phone.

With regard to existing contracts that have recently ended, FPL and the Solid Waste Authority of Palm Beach (SWA) agreed to extend their contract that expired March 31, 2010 for a 20-year term beginning in April 1, 2012 through April 1, 2032. However, the SWA refurbished their generating unit ahead of schedule and, as of January 2012, this unit began delivering firm capacity to FPL. In 2011, the FPSC approved a contract for an additional 70 MW between FPL and SWA for a new unit to be constructed. Construction has now commenced. At the end of December 2011, the contract between FPL and Okeelanta (New Hope) expired. However, Okeelanta continues to deliver energy to FPL as an as-available, non-firm supplier of renewable energy.

4) Supply Side Efforts – FPL Facilities:

With regard to solar generating facilities, FPL has three such facilities: (i) a 75 MW steam generation solar thermal facility in Martin County (the Martin Next Generation Solar Energy Center); (ii) a 25 MW PV electric generation facility in DeSoto County (the DeSoto Next Generation Solar Energy Center); and (iii) a 10 MW PV electric generation facility in Brevard County at NASA's Kennedy Space Center (the Space Coast Next Generation Solar Energy Center). The DeSoto County project was completed in 2009 and the other two projects were completed in 2010. These three solar facilities were constructed in response to the Florida Legislature's House Bill 7135 which was signed into law by then-Governor Crist in June 2008. House Bill 7135 was enacted to enable the development of clean, zero greenhouse gas emitting renewable generation in the State of Florida. Specifically, the bill authorized cost recovery for the first 110 MW of eligible renewable projects that had the proper land, zoning, and transmission rights in place. FPL's three solar projects met the specified criteria, and were granted approval for cost recovery in 2008. Each of the three solar facilities is discussed below.

a. The Martin Next Generation Solar Energy Center:

This facility began commercial operation in 2010 and provides 75 MW of solar thermal capacity in an innovative way that directly displaces fossil fuel usage on the FPL system. This facility consists of solar thermal technology which generates steam that is integrated into the existing steam cycle for the Martin Unit 8 natural gas-fired CC plant. This project is the first "hybrid" solar plant in the world, the second largest solar facility in the world, and the largest solar plant of any kind in the U.S. outside of California.

b. The DeSoto Next Generation Solar Energy Center:

This PV facility began commercial operation in 2009 and provides 25 MW of non-firm capacity and energy, making it one of the largest PV facilities in the U.S. The facility utilizes a tracking PV array that is designed to follow the sun as it traverses across the sky.

c. The Space Coast Next Generation Solar Energy Center:

Located at the Kennedy Space Center, this facility is part of an innovative public/private partnership with NASA. This non-tracking PV facility began commercial operation in 2010 and provides 10 MW of non-firm capacity and energy.

Collectively, these Next Generation Solar Energy Centers are expected to produce a total of approximately 200,000 megawatt-hours (MWh) of electricity each year, and at peak production provide enough energy to serve the requirements of more than 14,380 homes at current levels of average residential use.

For resource planning purposes, FPL currently projects that the output from these renewable facilities will be “as available,” non-firm energy only. This is due to several factors. First, the Martin solar thermal facility is a “fuel-substitute” facility, not a facility that provides additional capacity and energy. The solar thermal facility displaces the use of fossil fuel to produce steam on the FPL system when the solar thermal facility is operating. Second, in regard to the two PV facilities, the intermittent nature of the solar resource makes it difficult to accurately determine what contribution the PV facilities at these specific locations can consistently make at FPL’s late Summer afternoon and early Winter morning peak load hours. Once site-specific operating data has been gathered for an appropriate amount of time, FPL will then re-evaluate the actual output from each PV facility to determine what portion, if any, of its output can be projected as firm capacity at the projected peak hours in FPL’s resource planning work.

In addition to these three solar facilities, FPL is currently in the process of identifying other potential solar sites in the state in the event that a future Renewable Portfolio Standard (RPS), Clean Energy Portfolio Standard (CPS), or other energy legislation is enacted by the Florida legislature that enables FPL to construct and recover costs for additional renewable energy generation. FPL is evaluating existing FPL

generation sites along with potential Greenfield sites within FPL's service territory. These potential FPL and Greenfield sites are discussed further in Chapter IV.

FPL remains hopeful of developing a wind generation project on South Hutchinson Island in St. Lucie County. This project is known as the St. Lucie Wind Project and it would consist of up to six wind turbine generators capable of generating up to approximately 13.8 MW. In 2007, FPL began the St. Lucie County land use approval process, and soon after applied for the necessary federal and state permitting. However, a decision by the state and federal agencies on the St. Lucie Wind Project's permitting cannot be finalized until the local land use approval process is completed. At the time this Site Plan document is being developed, the local land use approval process has not been completed. An in-service date for the project is dependent upon a successful outcome in the local approval and permitting process.

5) Ongoing Research & Development Efforts:

FPL has developed alliances with several Florida universities to promote development of emerging technologies. For example, an alliance has been established with the newly formed Southeast National Marine Renewable Energy Center (SNMREC) at Florida Atlantic University (FAU), which will focus on the commercialization of ocean current, ocean thermal (i.e., energy conversion as well as cold water air conditioning), and hydrogen technologies. FPL has been taking the lead in assisting FAU with the discussions being held with the U.S. Department of the Interior's Minerals Bureau of Ocean Energy Management Regulation and Enforcement (BOEMRE). BOEMRE is working to establish the permitting process for ocean energy development on the outer continental shelf.

FPL has also developed an alliance with the University of Florida to support its biomass-related studies to determine improved vegetative management techniques for use in minimizing maintenance costs at FPL's current and future solar sites and to perform wind studies within the state. In addition, FPL has partnered with the Florida Institute of Technology on fuel cell technology and with the Florida State Universities Center for Applied Power System in regard to grid integration of ocean energy and other renewables.

FPL has also developed a "Living Lab" to demonstrate FPL's solar energy commitment to employees and visitors at its Juno Beach office facility. To-date, FPL has installed five different PV arrays (different technologies) of rooftop PV totaling 24

kW at the Living Lab. In addition, construction of two PV-covered parking structures with a total of approximately 90 kW of PV is near completion at the FPL Juno office parking lot. Through these Living Lab projects, FPL is able to evaluate multiple solar technologies and applications for the purpose of developing a renewable business model resulting in the most cost-effective and reliable uses of solar energy for FPL's customers. FPL plans to continue to expand the Living Lab as new solar products come to market.

FPL has also been in discussions with several private companies on multiple emerging technology initiatives including ocean current, ocean thermal, hydrogen, fuel cell technology, biomass, biofuels, and energy storage.

III.G FPL's Fuel Mix and Fuel Price Forecasts

1. FPL's Fuel Mix

Until the mid-1980s, FPL relied primarily on a combination of fuel oil, natural gas, and nuclear energy to generate electricity with significant reliance on oil-fired generation. In the early 1980s, FPL began to purchase "coal-by-wire." In 1987, coal was first added to the fuel mix through FPL's partial ownership (20%) and additional purchases (30%) from the St. Johns River Power Park (SJRPP). This allowed FPL to meet its customers' energy needs with a more diversified mix of energy sources. Additional coal resources were added with the partial acquisition (76%) of Scherer Unit 4 which began serving FPL's customers in 1991. Starting in 1997, petroleum coke was added to the fuel mix as a blend stock with coal at SJRPP when economic.

The trend since the early 1990s has been a steady increase in the amount of natural gas that is used by FPL to provide electricity due, in part, to the introduction of highly efficient and cost-effective CC generating units and the ready availability of natural gas. This planning document reflects an evolution in that trend in recognition that, although efficient gas-fired generation continues to provide significant benefits to FPL's customers, adding natural gas-fired additions exclusively would, in the long term, create an unbalanced generation portfolio. In 2009, FPL placed into commercial operation two new gas-fired CC units at the West County Energy Center (WCEC) site. A third new CC unit was added to the WCEC site in 2011. In addition, FPL is currently modernizing its existing Cape Canaveral and Riviera plant sites by removing the steam generating units previously on the sites and replacing them with two highly efficient new CC units, one at each site. FPL has also recently received

FPSC approval to perform a similar modernization project at its Port Everglades site. These new CC units will provide highly efficient generation that will dramatically improve the efficiency of FPL's generation system in general, and, more specifically, the efficiency at which natural gas is utilized..

In addition, FPL is increasing its utilization of nuclear energy through capacity uprates of its four existing nuclear units. These uprates have begun and will add a total of approximately 490 MW of nuclear generation capacity by early 2013. 31 MW of the projected 490 MW total increase have already been added at FPL's St. Lucie Unit 2 and this increased nuclear capacity is already benefitting FPL's customers. (FPL is also pursuing plans to obtain licenses, permits, and approvals to construct and operate two new nuclear units at its existing Turkey Point site that, in total, would add approximately 2,200 MW of new nuclear generating capacity. The earliest dates by which those new nuclear units could practically be deployed continue to be outside of the ten-year reporting time frame of this document.)

In regard to utilizing renewable energy, FPL has added 110 MW of solar generating capacity through a 75 MW solar thermal steam generating facility at FPL's existing Martin site, a 25 MW PV facility in DeSoto County, and a 10 MW PV facility in Brevard County. The DeSoto facility was placed into commercial operation in 2009. The other two solar facilities were placed into commercial operation in 2010.

FPL's future resource planning work will continue to focus on identifying and evaluating alternatives that would most cost-effectively maintain and/or enhance FPL's long-term fuel diversity. These fuel diverse alternatives may include: the purchase of power from renewable energy facilities, additional FPL-owned renewable energy facilities, obtaining additional access to diversified sources of natural gas such as liquefied natural gas (LNG) and natural gas from the Mid-Continent unconventional reserves, preserving FPL's ability to utilize fuel oil at its existing units, and increased utilization of nuclear energy. (As previously discussed, new advanced technology coal generating units are not currently considered as viable options in Florida in the ten-year reporting period of this document due, in part, to current projections of relatively small differences in fuel costs between coal and natural gas, significantly higher capital costs for coal units compared to CC units, greater efficiencies of CC units, and concerns over non-greenhouse gas environmental regulations that would impact coal units more negatively than CC units.) The

evaluation of the feasibility and cost-effectiveness of these, and other possible fuel diversity alternatives, will be part of on-going resource planning efforts.

FPL's current use of various fuels to supply energy to customers, plus a projection of this "fuel mix" through 2021 based on the resource plan presented in this document, is presented in Schedules 5, 6.1, and 6.2 later in this chapter.

2. FPL's Fossil Fuel Cost Forecasts

Fossil fuel price forecasts, and the resulting projected price differentials between fuels, are major drivers used in evaluating alternatives for meeting future resource needs. FPL's forecasts are generally consistent with other published contemporary forecasts.

Future oil and natural gas prices, and to a lesser extent, coal and petroleum coke prices, are inherently uncertain due to a significant number of unpredictable and uncontrollable drivers that influence the short- and long-term price of oil, natural gas, coal, and petroleum coke. These drivers include U.S. and worldwide demand, production capacity, economic growth, environmental legislation, and politics.

The inherent uncertainty and unpredictability in these factors today and tomorrow clearly underscores the need to develop a set of plausible oil, natural gas, and solid fuel (coal and petroleum coke) price scenarios that will bound a reasonable set of long-term price outcomes. In this light, FPL developed and utilized Low, Medium, and High price forecasts for fossil fuels in some of its 2011 and early 2012 resource planning work, particularly in regard to analyses conducted as part of the nuclear cost recovery filing work.

FPL's Medium price forecast methodology is consistent for oil and natural gas. For oil and natural gas commodity prices, FPL's Medium price forecast applies the following methodology:

- a. For 2011 through 2013, the methodology used the November 14, 2011 forward curve for New York Harbor 1% sulfur heavy oil, U. S. Gulf Coast 1% sulfur heavy oil, ultra low sulfur diesel fuel oil, and Henry Hub natural gas commodity prices;
- b. For the next two years (2014 and 2015), FPL used a 50/50 blend of the November 14, 2011 forward curve and the most current projections at the time from The PIRA Energy Group;

- c. For the 2016 through 2025 period, FPL used the annual projections from The PIRA Energy Group; and,
- d. For the period beyond 2025, FPL used the real rate of escalation from the Energy Information Administration (EIA). In addition to the development of oil and natural gas commodity prices, nominal price forecasts also were prepared for oil and natural gas transportation costs. The addition of commodity and transportation forecasts resulted in delivered price forecasts.

FPL's Medium price forecast methodology is also consistent for coal and petroleum coke prices. Coal and petroleum coke prices were based upon the following approach:

- a. Delivered price forecasts for Central Appalachian (CAPP), Illinois Basin (IB), Powder River Basin (PRB), and South American coal and petroleum coke were provided by JD Energy; and,
- b. The coal price forecast for SJRPP and Plant Scherer assume the continuation of the existing mine-mouth and transportation contracts until expiration, along with the purchase of spot coal, to meet generation requirements.

The development of FPL's Low and High price forecasts for oil, natural gas, coal, and petroleum coke prices were based on the historical volatility of the 12-month forward price, one year ahead. FPL developed these forecasts to account for the uncertainty which exists within each commodity as well as across commodities. These forecasts reflect a range of reasonable forecast outcomes.

3. Nuclear Fuel Cost Forecast

This section reviews the various steps needed to fabricate nuclear fuel for delivery to the nuclear power plants, the method used to forecast the price for each step, and other comments regarding FPL's nuclear fuel cost forecast.

a) Steps Required for Nuclear Fuel to be delivered to FPL's Plants

Four separate steps are required before nuclear fuel can be used in a commercial nuclear power reactor. These steps are summarized below.

(1) Mining: Uranium is produced in many countries such as Canada, Australia, Kazakhstan, and the United States. During the first step, uranium is mined from

the ground using techniques such as open pit mining, underground mining, in-situ leaching operations, or production as a by-product from other mining operations, such as gold, copper, or phosphate rocks. The product from this first step is the raw uranium delivered as an oxide, U₃O₈ (sometimes referred to as yellowcake).

(2) Conversion: During the second step, the U₃O₈ is chemically converted into UF₆ which, when heated, changes into a gaseous state. This second step further removes any chemical impurities and serves as preparation for the third step, which requires uranium to be in a gaseous state.

(3) Enrichment: The third step is called enrichment. Natural uranium contains 0.711% of uranium at an atomic mass of 235 (U-235) and 99.289% of uranium at an atomic mass of 238 (U-238). FPL's nuclear reactors use uranium with a higher percentage of up to five percent (5%) of U-235 atoms. Because natural uranium does not contain a sufficient amount of U-235, the third step increases the percentage amount of U-235 from 0.711% to a level specified when designing the reactor core (typically in a range from approximately 3% to as high as 5%). The output of this enrichment process is enriched uranium in the form of UF₆.

(4) Fabrication: During the last step, fuel fabrication, the enriched UF₆ is changed to a UO₂ powder, pressed into pellets, and fed into tubes, which are sealed and bundled together into fuel assemblies. These fuel assemblies are then delivered to the plant site for insertion in a reactor.

Like other utilities, FPL has purchased raw uranium and the other components of the nuclear fuel cycle separately from numerous suppliers from different countries.

b) Price Forecasts for Each Step

(1) Mining: There is some volatility in the current uranium market. Current demand continues to be rather stable and outputs from production facilities have been increasing steadily. The following are the current major contributors that led to some volatility in the prices for uranium:

- In March 2011, an earthquake and tsunami struck the Fukushima nuclear complex in Japan. The immediate impact was a perceived

reduction in worldwide nuclear fuel demand and thus prices have generally declined, with some small periodic increases through 2011.

- Hedge funds are currently in the market. This causes more speculative demand, not tied to market fundamentals, and causes the market price to move according to news potentially affecting potential future supply/demand balance, or news regarding current suppliers.
- The large inventory from the U.S. Department of Energy (DOE) is being withheld from the market due to political pressure from suppliers. Some of this uranium finds its way into the market periodically to fund cleanup of certain Department of Energy facilities.
- The U.S. Department of Commerce (DOC) has imposed restrictions on the import of nuclear fuel from France and Russia.
- Although a limited number of new nuclear units is scheduled to start production in the U.S. during the next 5 to 10 years, other countries, more specifically China, have announced a significant increase in construction of new units which has caused a short term increase in the uranium market price.

Over a 10-year horizon, FPL expects the market to be more consistent with market fundamentals. The supply picture is more stable, with laws enacted to resolve the import of Russian-enriched uranium, by allowing some imports of Russian-enriched uranium to meet about 20-25% of needs for currently operating units, but with no restriction on the first core for new units and no restrictions after 2020. New and current facilities continue to add capacity to meet demands. Actual demand tends to grow over time because of the long lead time to build nuclear units. However, FPL cannot discount the possibility of future periodic sharp increase in prices, but believes such occurrences will likely be temporary in nature.

FPL's nuclear fuel price forecasts are the result of FPL's analysis based on inputs from various nuclear fuel market expert reports and studies.

(2) Conversion: FPL's price forecast considers the construction of new nuclear units. Just like for raw uranium, an increase in demand for conversion services would result from this need. Insufficient planned production is currently

forecasted after 2013 to meet the higher demand scenario, but is sufficient to meet most reference case scenarios. As with additional raw uranium production, supply will expand beyond current level once more firm commitments are made including commitments to building new nuclear units.

(3) Enrichment: As a result of the Fukushima events in March 2011, the near-term price of enrichment services has declined. However, plans for several of the new facilities that were expected to come on-line in the next few years have been delayed. Also, some of the current high operating cost diffusion plants are indicating that they will shutdown in the next year or two. As with supply for the other steps of the nuclear fuel cycle, expansion of future capacity is feasible within the lead time for constructing new nuclear units and any other projected increase in demand. Meanwhile, world supply and demand will continue to be balanced such that FPL expects adequate supply of enrichment services. The tight supply/demand profile will most likely cause the price of enrichment services to remain stable or decline for the next few years before starting to increase.

(4) Fabrication: Because the nuclear fuel fabrication process is highly regulated by the Nuclear Regulatory Commission (NRC), not all production facilities can qualify as suppliers to nuclear reactors in the U.S. Although world supply and demand is expected to show significant excess capacity for the foreseeable future, the gap is not as wide for U.S. supply and demand. The supply for the U.S. market is expected to be sufficient to meet U.S. demand for the foreseeable future.

c) Other Comments Regarding FPL's Nuclear Fuel Cost Forecast

The calculations for the nuclear fuel cost forecasts used in FPL's 2011 and early 2012 resource planning work were performed consistent with the method then used for FPL's Fuel Clause filings, including the assumption of refueling outages every 18 months and plant operation at power uprate levels. The costs for each step to fabricate the nuclear fuels were added to come up with the total costs of the fresh fuel to be loaded at each refueling (acquisition costs). The acquisition cost for each group of fresh fuel assemblies were then amortized over the energy produced by each group of fuel assemblies. FPL also added 1 mill per kilowatt hour net to reflect payment to DOE for spent fuel disposal.

**Schedule 5
Fuel Requirements
(for FPL only)**

Fuel Requirements	Units	Actual 1/		Forecasted									
		2010	2011	2012	2013	2014	2015	2016	2017	2018	2019	2020	2021
(1) Nuclear	Trillion BTU	250	241	208	286	303	285	307	307	294	306	308	294
(2) Coal	1,000 TON	3,191	3,135	2,895	3,497	3,254	3,832	3,699	4,069	3,713	4,065	3,761	4,079
(3) Residual (FO6) - Total	1,000 BBL	6,754	1,141	1,516	664	494	671	768	731	636	690	766	1,041
(4) Steam	1,000 BBL	6,754	1,141	1,516	664	494	671	768	731	636	690	766	1,041
(5) Distillate (FO2) - Total	1,000 BBL	522	332	2	51	0	0	15	5	9	32	63	76
(6) Steam	1,000 BBL	4	2	0	0	0	0	0	0	0	0	0	0
(7) CC	1,000 BBL	194	290	0	12	0	0	4	3	5	8	16	23
(8) CT	1,000 BBL	324	40	2	40	0	0	11	2	5	24	47	53
(9) Natural Gas - Total	1,000 MCF	504,996	555,988	565,962	514,784	535,140	545,403	546,986	563,767	588,554	586,343	602,249	624,406
(10) Steam	1,000 MCF	56,729	61,272	29,586	10,538	7,785	10,572	12,601	11,852	10,409	11,206	12,447	16,842
(11) CC	1,000 MCF	443,108	486,116	535,610	502,562	527,045	534,746	533,914	551,606	577,940	574,788	589,210	606,514
(12) CT	1,000 MCF	5,159	8,600	766	1,684	310	84	471	310	205	349	591	1,050

1/ Source: A Schedules.

Note: Solar contributions are provided on Schedules 6.1 and 6.2.

Schedule 6.1
Energy Sources

Energy Sources	Units	Actual ^{1/}		Forecasted									
		2010	2011	2012	2013	2014	2015	2016	2017	2018	2019	2020	2021
(1) Annual Energy Interchange ^{2/}	GWH	8,333	6,008	4,214	3,205	3,197	4,091	2,805	658	0	0	0	0
(2) Nuclear	GWH	22,850	21,510	19,162	26,493	28,076	26,465	28,458	28,463	27,286	28,376	28,545	27,288
(3) Coal	GWH	5,721	5,634	5,064	6,029	5,683	6,825	6,743	7,395	6,791	7,391	6,884	7,417
(4) Residual(FO6) -Total	GWH	4,081	630	971	422	314	430	491	468	407	441	490	666
(5) Steam	GWH	4,081	630	971	422	314	430	491	468	407	441	490	666
(6) Distillate(FO2) -Total	GWH	279	123	1	21	0	0	7	3	5	14	27	36
(7) Steam	GWH	2	1	0	0	0	0	0	0	0	0	0	0
(8) CC	GWH	143	107	0	9	0	0	4	2	4	6	13	19
(9) CT	GWH	134	15	1	12	0	0	4	1	2	7	14	17
(10) Natural Gas -Total	GWH	66,771	74,388	78,888	73,106	77,223	78,824	79,608	82,436	86,264	85,886	88,106	90,976
(11) Steam	GWH	5,041	5,429	2,828	995	739	1,008	1,197	1,127	989	1,066	1,184	1,603
(12) CC	GWH	61,304	68,328	75,999	72,005	76,457	77,809	78,376	81,285	85,258	84,795	86,879	89,293
(13) CT	GWH	426	631	61	105	27	7	35	24	16	26	44	80
(14) Solar ^{3/}	GWH	69	71	195	209	209	186	208	192	207	206	200	206
(15) PV	GWH	69	71	73	72	72	71	71	70	70	69	69	68
(16) Solar Thermal ^{4/}	GWH	0	0	122	137	137	115	138	122	137	137	131	137
(17) Other ^{5/}	GWH	6,441	4,090	2,662	3,003	3,280	4,587	4,990	5,192	5,310	5,604	6,380	7,057
Net Energy For Load ^{6/}	GWH	114,475	112,454	111,156	112,487	117,982	121,407	123,310	124,806	126,270	127,919	130,631	133,646

1/ Source: A Schedules

2/ The projected figures are based on estimated energy purchases from SJRPP and the Southern Companies (UPS contract).

3/ Represents output from FPL's PV and solar thermal facilities.

4/ Estimated projected values. Solar thermal does not produce GWh, but produces steam that displaces fossil fuel-derived steam. Its 2011 contribution to the Martin 8 CC GWh output is rolled into row (12) for reporting purposes. Its projected contributions for 2012 - 2021 are provided separately on row (16).

5/ Represents a forecast of energy expected to be purchased from Qualifying Facilities, Independent Power Producers, net of Economy and other Power Sales.

6/ Net Energy For Load values for the years 2012 - 2021 are also shown in Col. (19) on Schedule 2.3.

**Schedule 6.2
Energy Sources % by Fuel Type**

Energy Source	Units	Actual ^{1/}		Forecasted									
		2010	2011	2012	2013	2014	2015	2016	2017	2018	2019	2020	2021
(1) Annual Energy Interchange ^{2/}	%	7.3	5.3	3.8	2.8	2.7	3.4	2.3	0.5	0.0	0.0	0.0	0.0
(2) Nuclear	%	20.0	19.1	17.2	23.6	23.8	21.8	23.1	22.8	21.6	22.2	21.9	20.4
(3) Coal	%	5.0	5.0	4.6	5.4	4.8	5.6	5.5	5.9	5.4	5.8	5.3	5.5
(4) Residual (FO6) -Total	%	3.6	0.6	0.9	0.4	0.3	0.4	0.4	0.4	0.3	0.3	0.4	0.5
(5) Steam	%	3.6	0.6	0.9	0.4	0.3	0.4	0.4	0.4	0.3	0.3	0.4	0.5
(6) Distillate (FO2) -Total	%	0.2	0.1	0.0	0.0	0.0	0.0	0.0	0.0	0.0	0.0	0.0	0.0
(7) Steam	%	0.0	0.0	0.0	0.0	0.0	0.0	0.0	0.0	0.0	0.0	0.0	0.0
(8) CC	%	0.1	0.1	0.0	0.0	0.0	0.0	0.0	0.0	0.0	0.0	0.0	0.0
(9) CT	%	0.1	0.0	0.0	0.0	0.0	0.0	0.0	0.0	0.0	0.0	0.0	0.0
(10) Natural Gas -Total	%	58.3	66.1	71.0	65.0	65.5	64.9	64.6	66.1	68.3	67.1	67.4	68.1
(11) Steam	%	4.4	4.8	2.5	0.9	0.6	0.8	1.0	0.9	0.8	0.8	0.9	1.2
(12) CC	%	53.6	60.8	68.4	64.0	64.8	64.1	63.6	65.1	67.5	66.3	66.5	66.8
(13) CT	%	0.4	0.6	0.1	0.1	0.0	0.0	0.0	0.0	0.0	0.0	0.0	0.1
(14) Solar ^{3/}	%	0.1	0.1	0.2	0.2	0.2	0.2	0.2	0.2	0.2	0.2	0.2	0.2
(15) PV	%	0.1	0.1	0.1	0.1	0.1	0.1	0.1	0.1	0.1	0.1	0.1	0.1
(16) Solar Thermal ^{4/}	%	0.0	0.0	0.1	0.1	0.1	0.1	0.1	0.1	0.1	0.1	0.1	0.1
(17) Other ^{5/}	%	5.6	3.6	2.4	2.7	2.8	3.8	4.0	4.2	4.2	4.4	4.9	5.3
		100	100	100	100	100	100	100	100	100	100	100	100

1/ Source: A Schedules

2/ The projected figures are based on estimated energy purchases from SJRPP and the Southern Companies (UPS contract).

3/ Represents output from FPL's PV and solar thermal facilities.

4/ Estimated projected values. Solar thermal does not produce GWh, but produces steam that displaces fossil fuel-derived steam.

Its 2011 contribution to the Martin 8 CC GWh output is rolled into row (12) for reporting purposes. Its projected contributions for 2012 - 2021 are provided separately on row (16).

5/ Represents a forecast of energy expected to be purchased from Qualifying Facilities, Independent Power Producers, net of Economy and other Power Sales.

6/ Net Energy For Load values for the years 2012 - 2021 are also shown in Col. (19) on Schedule 2.3.

**Schedule 7.1
Forecast of Capacity, Demand, and Scheduled
Maintenance At Time Of Summer Peak**

(1)	(2)	(3)	(4)	(5)	(6)	(7)	(8)	(9)	(10)	(11)	(12)	(13)	(14)
August of Year	Firm Installed Capacity MW	Firm Capacity Import MW	Firm Capacity Export MW	Firm QF MW	Total Firm Capacity Available MW	Total Demand MW	DSM MW	Firm Summer Demand MW	Reserve Margin Before Maintenance MW	% of Peak	Scheduled Maintenance MW	Reserve Margin After Maintenance MW	% of Peak
	2012	23,502	1,733	0	635	25,870	21,623	1,991	19,632	6,238	31.8	745	5,493
2013	24,208	1,303	0	635	26,146	21,931	2,114	19,817	6,329	31.9	826	5,503	27.8
2014	25,482	1,303	0	635	27,420	23,243	2,277	20,966	6,453	30.8	826	5,627	26.8
2015	25,553	1,303	0	635	27,491	23,786	2,408	21,378	6,113	28.6	0	6,113	28.6
2016	26,434	375	0	705	27,514	24,315	2,540	21,775	5,738	26.4	0	5,738	26.4
2017	26,434	0	0	705	27,139	24,529	2,671	21,858	5,280	24.2	0	5,280	24.2
2018	26,434	0	0	705	27,139	24,674	2,802	21,871	5,267	24.1	0	5,267	24.1
2019	26,434	0	0	705	27,139	25,041	2,934	22,107	5,031	22.8	0	5,031	22.8
2020	26,434	0	0	705	27,139	25,499	3,043	22,456	4,683	20.9	0	4,683	20.9
2021	26,684	0	0	705	27,389	25,960	3,143	22,817	4,572	20.0	0	4,572	20.0

Col. (2) represents capacity additions and changes projected to be in-service by June 1st. These MW are generally considered to be available to meet Summer peak loads which are forecasted to occur during August of the year indicated.

Col. (6) = Col.(2) + Col.(3) - Col.(4) + Col.(5).

Col. (7) reflects the 2011 load forecast without incremental DSM or cumulative load management.

Col. (8) represents cumulative load management capability, plus incremental conservation, from 1/2012-on intended for use with the 2011 load forecast.

Col. (10) = Col. (6) - Col. (9)

Col. (11) = Col.(10) / Col.(9)

Col. (12) indicates the capacity of units projected to be out-of-service for planned maintenance during the Summer peak period. This value is comprised of:

(i) 745 MW (at St. Lucie Unit 2) of nuclear capacity that will be out-of-service during part of Summer in 2012 due to an extended planned outage as part of the capacity uprates project;

(ii) an additional 826 MW of fossil-fueled capacity that will be out-of-service in the Summer of 2013 (at Martin Unit 1) and in the Summer of 2014 (at Martin Unit 2) due to the installation of electrostatic precipitators.

Col. (13) = Col. (10) - Col. (12)

Col. (14) = Col.(13) / Col.(9)

**Schedule 7.2
Forecast of Capacity , Demand, and Scheduled
Maintenance At Time of Winter Peak**

(1)	(2)	(3)	(4)	(5)	(6)	(7)	(8)	(9)	(10)	(11)	(12)	(13)	(14)
January of Year	Firm Installed Capacity MW	Firm Capacity Import MW	Firm Capacity Export MW	Firm QF MW	Total Firm Capacity Available MW	Total Peak Demand MW	DSM MW	Firm Winter Peak Demand MW	Reserve Margin Before Maintenance MW	% of Peak	Scheduled Maintenance MW	Reserve Margin After Maintenance MW	% of Peak
2012	24,513	1,866	0	635	27,014	20,889	1,673	19,216	7,797	40.6	1,675	6,122	31.9
2013	24,104	1,311	0	635	26,050	21,101	1,787	19,314	6,735	34.9	1,539	5,196	26.9
2014	25,617	1,311	0	635	27,563	21,959	1,946	20,014	7,549	37.7	832	6,717	33.6
2015	27,034	1,311	0	635	28,980	22,412	2,070	20,342	8,638	42.5	0	8,638	42.5
2016	27,084	383	0	705	28,172	22,675	2,194	20,481	7,691	37.6	0	7,691	37.6
2017	28,115	383	0	705	29,203	22,902	2,319	20,584	8,619	41.9	0	8,619	41.9
2018	28,115	0	0	705	28,820	23,151	2,444	20,708	8,112	39.2	0	8,112	39.2
2019	28,115	0	0	705	28,820	23,403	2,568	20,835	7,985	38.3	0	7,985	38.3
2020	28,115	0	0	705	28,820	23,667	2,667	21,000	7,819	37.2	0	7,819	37.2
2021	28,115	0	0	705	28,820	23,952	2,757	21,195	7,624	36.0	0	7,624	36.0

Col. (2) represents capacity additions and changes projected to be in-service by January 1st. These MW are generally considered to be available to meet winter peak loads which are forecasted to occur during January of the year indicated.

Col. (6) = Col.(2) + Col.(3) - Col.(4) + Col.(5).

Col. (7) reflects the 2011 load forecast without incremental DSM or cumulative load management. 2011 load is an actual load value.

Col. (8) represents cumulative load management capability, plus incremental conservation, from 1/2011-on intended for use with the 2011 load forecast.

Col. (10) = Col. (6) - Col. (9)

Col. (11) = Col.(10) / Col.(9)

Col. (12) indicates the capacity of units projected to be out-of-service for planned maintenance during the Winter peak period. This value is comprised of:

(i) an additional 853 MW (at St. Lucie Unit 1) of nuclear capacity that will be out-of-service during part of the Winter of 2012 due to extended planned outages as part of the capacity uprates project; (ii) 717 MW (at Turkey Point Unit 4) that will be out-of-service in Winter of 2013 due to an extended planned outage as part of the capacity uprates project; (iii) an additional 822 MW that will be out-of-service in the Winter of 2012 (at Manatee Unit 2) and in the Winter of 2013 (at Manatee Unit 1) due to the installation of electrostatic precipitators; and (iv) an additional 832 MW (at Martin Unit 1) that will be out-of-service during the Winter of 2014 due to the installation of electrostatic precipitators.

Col. (13) = Col. (10) - Col. (12)

Col. (14) = Col.(13) / Col.(9)

**Schedule 7.3
Projection of Generation - Only Reserves
At Time Of Summer Peak (Assuming PEEC in 2016 but no 2021 PPA)**

(1)	(2)	(3)	(4)	(5)	(6)	(7)	(8)	(9)	(10)	(11)	(12)	(13)	(14)
August of Year	Firm Installed Capacity MW	Firm Capacity Import MW	Firm Capacity Export MW	QF MW	Total Firm Capacity MW	Total Peak Demand MW	DSM MW	Firm Summer Peak Demand MW	Reserve Margin Before Maintenance MW % of Peak	Scheduled Maintenance MW	Reserve Margin After Maintenance MW % of Peak		
	2012	23,502	1,733	0	635	25,870	21,623	0	21,623	4,246	19.6	745	3,501
2013	24,208	1,303	0	635	26,146	21,931	0	21,931	4,214	19.2	826	3,388	15.5
2014	25,482	1,303	0	635	27,420	23,243	0	23,243	4,176	18.0	826	3,350	14.4
2015	25,553	1,303	0	635	27,491	23,786	0	23,786	3,704	15.6	0	3,704	15.6
2016	26,434	375	0	705	27,514	24,315	0	24,315	3,199	13.2	0	3,199	13.2
2017	26,434	0	0	705	27,139	24,529	0	24,529	2,609	10.6	0	2,609	10.6
2018	26,434	0	0	705	27,139	24,674	0	24,674	2,465	10.0	0	2,465	10.0
2019	26,434	0	0	705	27,139	25,041	0	25,041	2,097	8.4	0	2,097	8.4
2020	26,434	0	0	705	27,139	25,499	0	25,499	1,640	6.4	0	1,640	6.4
2021	26,434	0	0	705	27,139	25,960	0	25,960	1,179	4.5	0	1,179	4.5

Col. (2) represents capacity additions and changes, **assuming no generation additions in 2021.**

Col. (6) = Col.(2) + Col.(3) - Col.(4) + Col.(5).

Col. (7) reflects the load forecast without incremental DSM or cumulative load management.

Col. (8) shows zero contribution from DSM in order to calculate FPL's reserves that are supplied only by generation resource

Col. (10) = Col. (6) - Col. (9)

Col. (11) = Col.(10) / Col.(9)

Col. (12) indicates the capacity of units projected to be out-of-service for planned maintenance during the Summer peak period. This value is comprised of: (i) 745 MW (at St. Lucie Unit 2) of nuclear capacity that will be out-of-service during part of Summer in 2012 due to an extended planned outage as part of the capacity uprates project; and (ii) an additional 826 MW of fossil-fueled capacity that will be out-of-service in the Summer of 2013 (at Martin Unit 1) and in the Summer of 2014 (at M. due to the installation of electrostatic precipitators.

Col. (13) = Col. (10) - Col. (12)

Col. (14) = Col.(13) / Col.(9)

**Schedule 7.4
Projection of Generation - Only Reserves
At Time Of Summer Peak (Assuming PEEC in 2016 and 2021 PPA)**

(1)	(2)	(3)	(4)	(5)	(6)	(7)	(8)	(9)	(10)	(11)	(12)	(13)	(14)
August of Year	Firm Installed Capacity MW	Firm Capacity Import MW	Firm Capacity Export MW	QF MW	Total Firm Capacity MW	Total Peak Demand MW	DSM MW	Firm Summer Peak Demand MW	Reserve Margin Before Maintenance MW % of Peak	Scheduled Maintenance MW	Reserve Margin After Maintenance MW % of Peak		
	2012	23,502	1,733	0	635	25,870	21,623	0	21,623	4,246	19.6	745	3,501
2013	24,208	1,303	0	635	26,146	21,931	0	21,931	4,214	19.2	826	3,388	15.5
2014	25,482	1,303	0	635	27,420	23,243	0	23,243	4,176	18.0	826	3,350	14.4
2015	25,553	1,303	0	635	27,491	23,786	0	23,786	3,704	15.6	0	3,704	15.6
2016	26,434	375	0	705	27,514	24,315	0	24,315	3,199	13.2	0	3,199	13.2
2017	26,434	0	0	705	27,139	24,529	0	24,529	2,609	10.6	0	2,609	10.6
2018	26,434	0	0	705	27,139	24,674	0	24,674	2,465	10.0	0	2,465	10.0
2019	26,434	0	0	705	27,139	25,041	0	25,041	2,097	8.4	0	2,097	8.4
2020	26,434	0	0	705	27,139	25,499	0	25,499	1,640	6.4	0	1,640	6.4
2021	26,684	0	0	705	27,389	25,960	0	25,960	1,429	5.5	0	1,429	5.5

Col. (2) represents capacity additions and changes, assuming a 250 MW PPA is added in 2021.

Col. (6) = Col.(2) + Col.(3) - Col.(4) + Col.(5).

Col. (7) reflects the load forecast without incremental DSM or cumulative load management.

Col. (8) shows zero contribution from DSM in order to calculate FPL's reserves that are supplied only by generation resource

Col. (10) = Col. (6) - Col. (9)

Col. (11) = Col.(10) / Col.(9)

Col. (12) indicates the capacity of units projected to be out-of-service for planned maintenance during the Summer peak period. This value is comprised of: (i) an additional 745 MW (at St. Lucie Unit 2) of nuclear capacity that will be out-of-service during part of Summer in 2012 due to an extended planned outage as part of the capacity uprates project; and (ii) an additional 826 MW of fossil-fueled capacity that will be out-of-service in the Summer of 2013 (at Martin Unit 1) and in the Summer of 2014 (at M. due to the installation of electrostatic precipitators.

Col. (13) = Col. (10) - Col. (12)

Col. (14) = Col.(13) / Col.(9)

**Schedule 8
Planned And Prospective Generating Facility Additions And Changes**

Plant Name	Unit No.	Location	Unit Type	(5) Pri.	(5) Alt.	Fuel		(9) Const. Start Mo./Yr.	(10) Comm. In-Service Mo./Yr.	(11) Expected Retirement Mo./Yr.	(12) Gen. Max. Nameplate KW	Firm Net Capability ⁽¹⁾		(15) Status
						(7) Pri.	(8) Alt.					(13) Winter MW	(14) Summer MW	
						(4) (5) (7) (8)								
ADDITIONS/ CHANGES														
2012														
Manatee	2	Manatee County	ST	FO6	NG	WA	PL	May-12	Jun-12	Unknown	863,300	---	(3)	P
Scherer	4	Monroe, GA	BIT	SUB	No	RR	No	Apr-12	May-12	Unknown	680,368	---	(30)	P
Sanford CT Upgrade	5A	Volusia County	CC	NG	No	PL	No	Feb-12	Mar-12	Unknown	1,188,860	---	10	P
Sanford CT Upgrade	5D	Volusia County	CC	NG	No	PL	No	Feb-12	Mar-12	Unknown	1,188,860	---	9	P
St. Lucie (Uprates) ⁽²⁾	1	St. Lucie County	NP	UR	No	TK	No	See Note 2	Dec-11	Unknown	850,000	---	129	T
Turkey Point (Uprates) ⁽²⁾	3	Miami Dade County	NP	UR	No	TK	No	See Note 2	May-12	Unknown	759,900	---	123	T
2012 Changes/Additions w/o Inactive Reserve Total:												0	238	
Port Everglades	3	City of Hollywood	ST	FO6	NG	WA	PL	---	---	---	402,050	389	387	OT
Port Everglades	4	City of Hollywood	ST	FO6	NG	WA	PL	---	---	---	402,050	376	374	OT
2012 Changes/Additions with Inactive Reserve Total:												765	999	
2013														
Cape Canaveral Next Generation Clean Energy Center	1	Brevard County	CC	NG	FO2	PL	PL	Jun-11	Jun-13	Unknown	1,296,750	---	1,210	T
Scherer	4	Monroe, GA	BIT	SUB	No	RR	No	Unknown	May-12	Unknown	680,368	(28)	---	P
Manatee	2	Manatee County	ST	FO6	NG	WA	PL	May-12	Jun-12	Unknown	863,300	(3)	---	P
Sanford CT Upgrade	5A	Volusia County	CC	NG	No	PL	No	Feb-12	Mar-12	Unknown	1,188,860	10	---	P
Sanford CT Upgrade	5D	Volusia County	CC	NG	No	PL	No	Feb-12	Mar-12	Unknown	1,188,860	9	---	P
Sanford CT Upgrade	5C	Volusia County	CC	NG	No	PL	No	Jan-13	Feb-13	Unknown	1,188,860	---	9	P
Martin CT Upgrade	8B	Martin County	CC	NG	FO2	PL	PL	Nov-12	Dec-12	Unknown	1,224,510	10	10	P
Sanford CT Upgrade	4A	Volusia County	CC	NG	No	PL	No	Oct-12	Nov-12	Unknown	1,188,860	11	8	P
Sanford CT Upgrade	4B	Volusia County	CC	NG	No	PL	No	Sep-12	Oct-12	Unknown	1,188,860	11	7	P
Sanford CT Upgrade	4C	Volusia County	CC	NG	No	PL	No	Mar-13	Apr-13	Unknown	1,188,860	---	8	P
Sanford CT Upgrade	4D	Volusia County	CC	NG	No	PL	No	Mar-13	Mar-13	Unknown	1,188,860	---	8	P
St. Lucie (Uprates) ⁽²⁾	1	St. Lucie County	NP	UR	No	TK	No	---	See Note 2	Unknown	850,000	129	---	T
St. Lucie (Uprates) ⁽²⁾	2	St. Lucie County	NP	UR	No	TK	No	---	See Note 2	Unknown	723,775	84	84	T
Turkey Point (Uprates) ⁽²⁾	3	Miami Dade County	NP	UR	No	TK	No	---	See Note 2	Unknown	759,900	123	---	T
Turkey Point (Uprates) ⁽²⁾	4	Miami Dade County	NP	UR	No	TK	No	---	See Note 2	Unknown	759,900	---	123	T
2013 Changes/Additions w/o Inactive Reserve Total:												356	1,467	
Port Everglades	3	City of Hollywood	ST	FO6	NG	WA	PL	---	---	---	402,050	(389)	(387)	OT
Port Everglades	4	City of Hollywood	ST	FO6	NG	WA	PL	---	---	---	402,050	(376)	(374)	OT
2013 Changes/Additions with Inactive Reserve Total:												(409)	706	
2014														
Turkey Point (Uprates) ⁽²⁾	4	Miami Dade County	NP	UR	No	TK	No	---	See Note 2	Unknown	759,900	123	---	T
Sanford CT Upgrade	4C	Volusia County	CC	NG	No	PL	No	Mar-13	Apr-13	Unknown	1,188,860	8	---	P
Sanford CT Upgrade	4D	Volusia County	CC	NG	No	PL	No	Mar-13	Mar-13	Unknown	1,188,860	8	---	P
Sanford CT Upgrade	5B	Volusia County	CC	NG	No	PL	No	Aug-13	Sep-13	Unknown	1,188,860	10	---	P
Sanford CT Upgrade	5C	Volusia County	CC	NG	No	PL	No	Jan-13	Feb-13	Unknown	1,188,860	9	10	P
Manatee CT Upgrade	3C	Manatee County	CC	NG	No	PL	No	Apr-14	May-14	Unknown	1,224,510	---	10	P
Manatee CT Upgrade	3D	Manatee County	CC	NG	No	PL	No	Apr-14	May-14	Unknown	1,224,510	---	9	P
Turkey Point CT Upgrade	5A	Miami Dade County	CC	NG	FO2	PL	PL	Jan-14	Feb-14	Unknown	1,224,510	---	8	P
Turkey Point CT Upgrade	5B	Miami Dade County	CC	NG	FO2	PL	PL	Jan-14	Feb-14	Unknown	1,224,510	---	8	P
Turkey Point CT Upgrade	5C	Miami Dade County	CC	NG	FO2	PL	PL	Feb-14	Mar-14	Unknown	1,224,510	---	8	P
Turkey Point CT Upgrade	5D	Miami Dade County	CC	NG	FO2	PL	PL	Feb-14	Mar-14	Unknown	1,224,510	---	9	P
Cape Canaveral Next Generation Clean Energy Center	1	Brevard County	CC	NG	FO2	PL	PL	Jun-11	Jun-13	Unknown	1,296,750	1,355	---	T
Riviera Beach Next Generation Clean Energy Center	1	City of Riviera Beach	CC	NG	FO2	PL	PL	Jun-12	Jun-14	Unknown	1,296,750	---	1,212	T
2014 Changes/Additions w/o Inactive Reserve Total:												1,513	1,274	

(1): The Winter Total MW value consists of all generation additions and changes achieved by January. The Summer Total MW value consists of all generation additions and changes achieved by June.

All MW additions/changes occurring later in the year will be picked up for reporting/planning purposes in the following year.

(2) The nuclear uprates will be performed during the extended outages for each unit.

**Schedule 8
Planned And Prospective Generating Facility Additions And Changes**

Plant Name	Unit No.	Location	Unit Type	Fuel				Const. Start Mo./Yr.	Comm. In-Service Mo./Yr.	Expected Retirement Mo./Yr.	Gen. Max. Nameplate KW	Firm Net Capability ⁽¹⁾		Status
				Pri.	Alt.	Transport						Winter MW	Summer MW	
						Pri.	Alt.							
ADDITIONS/ CHANGES														
2015														
Riviera Beach Next Generation Clean Energy Center	1	City of Riviera Beach	CC	NG	FO2	PL	PL	Jun-12	Jun-14	Unknown	1,296,750	1,344	---	T
Manatee CT Upgrade	3A	Manatee County	CC	NG	No	PL	No	Aug-14	Sep-14	Unknown	1,224,510	10	10	P
Manatee CT Upgrade	3B	Manatee County	CC	NG	No	PL	No	Aug-14	Sep-14	Unknown	1,224,510	10	10	P
Manatee CT Upgrade	3C	Manatee County	CC	NG	No	PL	No	Apr-14	May-14	Unknown	1,224,510	10	---	P
Manatee CT Upgrade	3D	Manatee County	CC	NG	No	PL	No	Apr-14	May-14	Unknown	1,224,510	9	---	P
Turkey Point CT Upgrade	5A	Miami Dade County	CC	NG	FO2	PL	PL	Jan-14	Feb-14	Unknown	1,224,510	8	---	P
Turkey Point CT Upgrade	5B	Miami Dade County	CC	NG	FO2	PL	PL	Jan-14	Feb-14	Unknown	1,224,510	8	---	P
Turkey Point CT Upgrade	5C	Miami Dade County	CC	NG	FO2	PL	PL	Feb-14	Mar-14	Unknown	1,224,510	8	---	P
Turkey Point CT Upgrade	5D	Miami Dade County	CC	NG	FO2	PL	PL	Feb-14	Mar-14	Unknown	1,224,510	9	---	P
Ft. Myers CT Upgrade	2A	Lee County	CC	NG	No	PL	No	Jun-15	Jul-15	Unknown	1,775,390	---	8	P
Ft. Myers CT Upgrade	2B	Lee County	CC	NG	No	PL	No	Feb-15	Mar-15	Unknown	1,775,390	---	8	P
Ft. Myers CT Upgrade	2C	Lee County	CC	NG	No	PL	No	Jul-15	Aug-15	Unknown	1,775,390	---	9	P
Ft. Myers CT Upgrade	2D	Lee County	CC	NG	No	PL	No	May-15	Jun-15	Unknown	1,775,390	---	8	P
Ft. Myers CT Upgrade	2E	Lee County	CC	NG	No	PL	No	May-15	Jun-15	Unknown	1,775,390	---	9	P
Ft. Myers CT Upgrade	2F	Lee County	CC	NG	No	PL	No	Feb-15	Mar-15	Unknown	1,775,390	---	9	P
2015 Changes/Additions w/o Inactive Reserve Total:											1,416	71		
2016														
Port Everglades Next Generation Clean Energy Center	1	---	CC	NG	FO2	PL	PL	Jun-14	Jun-16	Unknown	Unknown	---	1,277	P
Ft. Myers CT Upgrade	2A	Lee County	CC	NG	No	PL	No	Jun-15	Jul-15	Unknown	1,775,390	8	---	P
Ft. Myers CT Upgrade	2B	Lee County	CC	NG	No	PL	No	Feb-15	Mar-15	Unknown	1,775,390	8	---	P
Ft. Myers CT Upgrade	2C	Lee County	CC	NG	No	PL	No	Jul-15	Aug-15	Unknown	1,775,390	9	---	P
Ft. Myers CT Upgrade	2D	Lee County	CC	NG	No	PL	No	May-15	Jun-15	Unknown	1,775,390	8	---	P
Ft. Myers CT Upgrade	2E	Lee County	CC	NG	No	PL	No	May-15	Jun-15	Unknown	1,775,390	9	---	P
Ft. Myers CT Upgrade	2F	Lee County	CC	NG	No	PL	No	Feb-15	Mar-15	Unknown	1,775,390	9	---	P
Turkey Point Synchronous condenser	1	Miami Dade County	ST	FO6	NG	WA	PL	---	---	Jun-16	402,050	---	(396)	P
2016 Changes/Additions w/o Inactive Reserve Total:											51	881		
2017														
Port Everglades Next Generation Clean Energy Center	1	---	CC	NG	FO2	PL	PL	Jun-14	Jun-16	Unknown	Unknown	1,429	---	P
Turkey Point Synchronous condenser	1	Miami Dade County	ST	FO6	NG	WA	PL	---	---	Jun-16	402,050	(398)	---	P
2017 Changes/Additions w/o Inactive Reserve Total:											1,031	0		
2018														
2018 Changes/Additions w/o Inactive Reserve Total:											0	0		
2019														
2019 Changes/Additions w/o Inactive Reserve Total:											0	0		
2020														
2020 Changes/Additions w/o Inactive Reserve Total:											0	0		
2021														
Short Term Purchase		---						Jun-18	Jun-20	Unknown	Unknown	---	250	P
2021 Changes/Additions w/o Inactive Reserve Total:											0	250		

(1) The Winter Total MW value consists of all generation additions and changes achieved by January. The Summer Total MW value consists of all generation additions and changes achieved by June. All MW additions/changes occurring later in the year will be picked up for reporting/planning purposes in the following year.
 (2) The nuclear uprates will be performed during the extended outages for each unit.

Schedule 9
Status Report and Specifications of Proposed Generating Facilities

- (1) **Plant Name and Unit Number:** St. Lucie 1 Nuclear (Uprate)
- (2) **Capacity**
a. Summer 129 MW (Incremental)
b. Winter 129 MW (Incremental)
- (3) **Technology Type:** Nuclear
- (4) **Anticipated Construction Timing**
a. Field construction start-date: During scheduled refueling outage
b. Commercial In-service date: 2012
- (5) **Fuel**
a. Primary Fuel Uranium
b. Alternate Fuel ---
- (6) **Air Pollution and Control Strategy:** No change from existing unit
- (7) **Cooling Method:** No change from existing unit
- (8) **Total Site Area:** No change from existing unit
- (9) **Construction Status:** T (Regulatory approval received, but not under construction)
- (10) **Certification Status:** T (Regulatory approval received, but not under construction)
- (11) **Status with Federal Agencies:** T (Regulatory approval received, but not under construction)
- (12) **Projected Unit Performance Data:**
Planned Outage Factor (POF): No change from existing unit
Forced Outage Factor (FOF): No change from existing unit
Equivalent Availability Factor (EAF): No change from existing unit
Resulting Capacity Factor (%): No change from existing unit
Average Net Operating Heat Rate (ANOHR): No change from existing unit
Base Operation 75F,100% No change from existing unit
- (13) **Projected Unit Financial Data ***
Book Life (Years): 25 years (Matches the current operating license period.)
Total Installed Cost (\$/kW): ** TBD (See Note (1) for explanation.)
Direct Construction Cost: TBD (See Note (1) for explanation.)
AFUDC Amount (\$/kW): (See Note (2) for explanation.)
Escalation (\$/kW): (See Note (3) for explanation.)
Fixed O&M (\$/kW -Yr.): There is no additional O&M impact from this project.
Variable O&M (\$/MWH): There is no additional O&M impact from this project.
K Factor: (See Note (2) for explanation.)

NOTE:

- (1) The projected capital cost values for the capacity uprates at each of FPL's existing nuclear units is currently being reviewed in on-going analyses as this document is being prepared. The capital cost projections that will result from these analyses are expected to be presented in FPL's May 2012 Nuclear Cost Recovery filing.
- (2) Not applicable due to early recovery of capital carrying costs.
- (3) These costs are included in the Total Installed Cost value.

* \$/kW values are based on incremental Summer capacity.
** \$/incremental kW

Schedule 9
Status Report and Specifications of Proposed Generating Facilities

- (1) **Plant Name and Unit Number:** Turkey Point 3 Nuclear (Uprate)
- (2) **Capacity**
a. Summer 123 MW (Incremental)
b. Winter 123 MW (Incremental)
- (3) **Technology Type:** Nuclear
- (4) **Anticipated Construction Timing**
a. Field construction start-date: During scheduled refueling outage
b. Commercial In-service date: 2012
- (5) **Fuel**
a. Primary Fuel Uranium
b. Alternate Fuel ---
- (6) **Air Pollution and Control Strategy:** No change from existing unit
- (7) **Cooling Method:** No change from existing unit
- (8) **Total Site Area:** No change from existing unit
- (9) **Construction Status:** T (Regulatory approval received, but not under construction)
- (10) **Certification Status:** T (Regulatory approval received, but not under construction)
- (11) **Status with Federal Agencies:** T (Regulatory approval received, but not under construction)
- (12) **Projected Unit Performance Data:**
Planned Outage Factor (POF): No change from existing unit
Forced Outage Factor (FOF): No change from existing unit
Equivalent Availability Factor (EAF): No change from existing unit
Resulting Capacity Factor (%): No change from existing unit
Average Net Operating Heat Rate (ANOHR): No change from existing unit
Base Operation 75F,100% No change from existing unit
- (13) **Projected Unit Financial Data ***
Book Life (Years): 21 years (Matches the current operating license period.)
Total Installed Cost (\$/kW): ** TBD (See Note (1) for explanation.)
Direct Construction Cost (\$/kW): TBD (See Note (1) for explanation.)
AFUDC Amount (\$/kW): (See Note (2) for explanation.)
Escalation (\$/kW): (See Note (3) for explanation.)
Fixed O&M (\$/kW -Yr.): There is no additional O&M impact from this project.
Variable O&M (\$/MWH): There is no additional O&M impact from this project.
K Factor: (See Note (2) for explanation.)

NOTE:

- (1) The projected capital cost values for the capacity uprates at each of FPL's existing nuclear units is currently being reviewed in on-going analyses as this document is being prepared. The capital cost projections that will result from these analyses are expected to be presented in FPL's May 2012 Nuclear Cost Recovery filing.
- (2) Not applicable due to early recovery of capital carrying costs.
- (3) These costs are included in the Total Installed Cost value.

* \$/kW values are based on incremental Summer capacity.
** \$/incremental kW

Schedule 9
Status Report and Specifications of Proposed Generating Facilities

- (1) **Plant Name and Unit Number:** St. Lucie 2 Nuclear (Uprate)
- (2) **Capacity**
a. Summer 84 MW (final incremental FPL's ownership share; 31 MW have already been achieved)
b. Winter 84 MW (final incremental FPL's ownership share; 31 MW have already been achieved)
- (3) **Technology Type:** Nuclear
- (4) **Anticipated Construction Timing**
a. Field construction start-date: During scheduled refueling outage
b. Commercial In-service date: 2012 (final increase)
- (5) **Fuel**
a. Primary Fuel Uranium
b. Alternate Fuel ---
- (6) **Air Pollution and Control Strategy:** No change from existing unit
- (7) **Cooling Method:** No change from existing unit
- (8) **Total Site Area:** No change from existing unit
- (9) **Construction Status:** T (Regulatory approval received, but not under construction)
- (10) **Certification Status:** T (Regulatory approval received, but not under construction)
- (11) **Status with Federal Agencies:** T (Regulatory approval received, but not under construction)
- (12) **Projected Unit Performance Data:**
Planned Outage Factor (POF): No change from existing unit
Forced Outage Factor (FOF): No change from existing unit
Equivalent Availability Factor (EAF): No change from existing unit
Resulting Capacity Factor (%): No change from existing unit
Average Net Operating Heat Rate (ANOHR): No change from existing unit
Base Operation 75F, 100% No change from existing unit
- (13) **Projected Unit Financial Data *,****
Book Life (Years): 32 years (Matches the current operating license period.)
Total Installed Cost (\$/kW): ** TBD (See Note (1) for explanation.)
Direct Construction Cost (\$/kW): TBD (See Note (1) for explanation.)
AFUDC Amount (\$/kW): (See Note (2) for explanation.)
Escalation (\$/kW): (See Note (3) for explanation.)
Fixed O&M (\$/kW -Yr.): There is no additional O&M impact from this project.
Variable O&M (\$/MWH): There is no additional O&M impact from this project.
K Factor: (See Note (2) for explanation.)

NOTE:

- (1) The projected capital cost values for the capacity uprates at each of FPL's existing nuclear units is currently being reviewed in on-going analyses as this document is being prepared. The capital cost projections that will result from these analyses are expected to be presented in FPL's May 2012 Nuclear Cost Recovery filing.
nuclear units.
- (2) Not applicable due to early recovery of capital carrying costs.
- (3) These costs are included in the Total Installed Cost value.

* \$/kW values are based on incremental Summer capacity.
** \$/incremental kW

Schedule 9
Status Report and Specifications of Proposed Generating Facilities

- (1) **Plant Name and Unit Number:** Turkey Point 4 Nuclear (Uprate)
- (2) **Capacity**
a. Summer 123 MW (Incremental)
b. Winter 123 MW (Incremental)
- (3) **Technology Type:** Nuclear
- (4) **Anticipated Construction Timing**
a. Field construction start-date: During scheduled refueling outage
b. Commercial In-service date: 2013
- (5) **Fuel**
a. Primary Fuel Uranium
b. Alternate Fuel ---
- (6) **Air Pollution and Control Strategy:** No change from existing unit
- (7) **Cooling Method:** No change from existing unit
- (8) **Total Site Area:** No change from existing unit
- (9) **Construction Status:** T (Regulatory approval received, but not under construction)
- (10) **Certification Status:** T (Regulatory approval received, but not under construction)
- (11) **Status with Federal Agencies:** T (Regulatory approval received, but not under construction)
- (12) **Projected Unit Performance Data:**
Planned Outage Factor (POF): No change from existing unit
Forced Outage Factor (FOF): No change from existing unit
Equivalent Availability Factor (EAF): No change from existing unit
Resulting Capacity Factor (%): No change from existing unit
Average Net Operating Heat Rate (ANOHR): No change from existing unit
Base Operation 75F,100% No change from existing unit
- (13) **Projected Unit Financial Data *,****
Book Life (Years): 21 years (Matches the current operating license period.)
Total Installed Cost (\$/kW): ** TBD (See Note (1) for explanation.)
Direct Construction Cost (\$/kW): TBD (See Note (1) for explanation.)
AFUDC Amount (\$/kW): (See Note (2) for explanation.)
Escalation (\$/kW): (See Note (3) for explanation.)
Fixed O&M (\$/kW -Yr.): There is no additional O&M impact from this project.
Variable O&M (\$/MWH): There is no additional O&M impact from this project.
K Factor: (See Note (2) for explanation.)

NOTE:

- (1) The projected capital cost values for the capacity uprates at each of FPL's existing nuclear units is currently being reviewed in on-going analyses as this document is being prepared. The capital cost projections that will result from these analyses are expected to be presented in FPL's May 2012 Nuclear Cost Recovery filing.
- (2) Not applicable due to early recovery of capital carrying costs.
- (3) These costs are included in the Total Installed Cost value.

* \$/kW values are based on incremental Summer capacity.

** \$/incremental kW

Schedule 9
Status Report and Specifications of Proposed Generating Facilities

- (1) **Plant Name and Unit Number:** Cape Canaveral Next Generation Clean Energy Center
- (2) **Capacity**
a. Summer 1,210 MW
b. Winter 1,355 MW
- (3) **Technology Type:** Combined Cycle
- (4) **Anticipated Construction Timing**
a. Field construction start-date: 2011
b. Commercial In-service date: 2013
- (5) **Fuel**
a. Primary Fuel Natural Gas
b. Alternate Fuel Ultra-low sulfur distillate
- (6) **Air Pollution and Control Strategy:** Dry Low No_x Burners, SCR, Natural Gas, 0.0015% S. Distillate and Water Injection on Distillate
- (7) **Cooling Method:** Once-through cooling water
- (8) **Total Site Area:** 43 Acres
- (9) **Construction Status:** U (Under construction, less than or equal to 50% complete)
- (10) **Certification Status:** Permitted
- (11) **Status with Federal Agencies:** Permitted
- (12) **Projected Unit Performance Data:**
Planned Outage Factor (POF): 2.4%
Forced Outage Factor (FOF): 1.1%
Equivalent Availability Factor (EAF): 96.5%
Resulting Capacity Factor (%): Approx. 90 % (First Full Year Base Operation)
Average Net Operating Heat Rate (ANOHR): 6,484 Btu/kWh
Base Operation 75F, 100%
- (13) **Projected Unit Financial Data *,****
Book Life (Years): 30 years
Total Installed Cost (2013 \$/kW): 921
Direct Construction Cost (\$/kW):
AFUDC Amount (\$/kW): 98
Escalation (\$/kW):
Fixed O&M (\$/kW-Yr): (2013 \$) 13.29
Variable O&M (\$/MWH): (2013 \$) 0.16
K Factor: 1.484

* \$/kW values are based on Summer capacity.

** Fixed O&M cost includes capital replacement.

NOTE: Total installed cost includes gas expansion, transmission interconnection and integration, escalation, and AFUDC. Demolition costs of existing plant are not included.

Schedule 9
Status Report and Specifications of Proposed Generating Facilities

- (1) **Plant Name and Unit Number:** Riviera Beach Next Generation Clean Energy Center
- (2) **Capacity**
a. Summer 1,212 MW
b. Winter 1,344 MW
- (3) **Technology Type:** Combined Cycle
- (4) **Anticipated Construction Timing**
a. Field construction start-date: 2012
b. Commercial In-service date: 2014
- (5) **Fuel**
a. Primary Fuel Natural Gas
b. Alternate Fuel Ultra-low sulfur distillate
- (6) **Air Pollution and Control Strategy:** Dry Low No_x Burners, SCR, Natural Gas, 0.0015% S. Distillate and Water Injection on Distillate
- (7) **Cooling Method:** Once-through cooling water
- (8) **Total Site Area:** 33 Acres
- (9) **Construction Status:** U (Under construction, less than or equal to 50% complete)
- (10) **Certification Status:** Permitted
- (11) **Status with Federal Agencies:** Permitted
- (12) **Projected Unit Performance Data:**
Planned Outage Factor (POF): 2.4%
Forced Outage Factor (FOF): 1.1%
Equivalent Availability Factor (EAF): 96.5%
Resulting Capacity Factor (%): Approx. 90% (First Full Year Base Operation)
Average Net Operating Heat Rate (ANOHR): 6,480 Btu/kWh
Base Operation 75F, 100%
- (13) **Projected Unit Financial Data *,****
Book Life (Years): 30 years
Total Installed Cost (2014 \$/kW): 1,053
Direct Construction Cost (\$/kW):
AFUDC Amount (\$/kW): 121
Escalation (\$/kW):
Fixed O&M (\$/kW-Yr): (2014 \$) 13.67
Variable O&M (\$/MWH): (2014 \$) 0.13
K Factor: 1.509

* \$/kW values are based on Summer capacity.
** Fixed O&M cost includes capital replacement.

NOTE: Total installed cost includes gas expansion, transmission interconnection and integration, escalation, and AFUDC. Demolition costs of existing plant are not included.

Schedule 9
Status Report and Specifications of Proposed Generating Facilities

- (1) **Plant Name and Unit Number:** Port Everglades Next Generation Clean Energy Center
- (2) **Capacity**
a. Summer 1,277 MW
b. Winter 1,429 MW
- (3) **Technology Type:** Combined Cycle
- (4) **Anticipated Construction Timing**
a. Field construction start-date: 2014
b. Commercial In-service date: 2016
- (5) **Fuel**
a. Primary Fuel Natural Gas
b. Alternate Fuel Ultra-low sulfur distillate
- (6) **Air Pollution and Control Strategy:** Dry Low No_x Burners, SCR, Natural Gas, 0.0015% S. Distillate and Water Injection on Distillate
- (7) **Cooling Method:** Once-through cooling water
- (8) **Total Site Area:** Existing Site Acres
- (9) **Construction Status:** P (Planned Unit)
- (10) **Certification Status:** ---
- (11) **Status with Federal Agencies:** ---
- (12) **Projected Unit Performance Data:**
Planned Outage Factor (POF): 3.5%
Forced Outage Factor (FOF): 1.1%
Equivalent Availability Factor (EAF): 95.4%
Resulting Capacity Factor (%): Approx. 90% (First Full Year Base Operation)
Average Net Operating Heat Rate (ANOHR): 6,330 Btu/kWh
Base Operation 75F, 100%
- (13) **Projected Unit Financial Data *,****
Book Life (Years): 30 years
Total Installed Cost (2016 \$/kW): 928
Direct Construction Cost (\$/kW):
AFUDC Amount (\$/kW): 87
Escalation (\$/kW):
Fixed O&M (\$/kW-Yr): (2016 \$) 30.00
Variable O&M (\$/MWH): (2016 \$) 0.10
K Factor: 1.51

* \$/kW values are based on Summer capacity.
** Fixed O&M cost includes capital replacement.

NOTE: Total installed cost includes gas expansion, transmission interconnection and integration, escalation, and AFUDC. Demolition costs of existing plant are not included.

Schedule 10
Status Report and Specifications of Proposed Transmission Lines

St. Lucie 1 Nuclear (Uprate)

The St. Lucie 1 Nuclear (Uprate) does not require any “new” transmission lines.

Schedule 10
Status Report and Specifications of Proposed Transmission Lines

Turkey Point 3 Nuclear (Uprate)

The Turkey Point 3 Nuclear (Uprate) does not require any “new” transmission lines.

Schedule 10
Status Report and Specifications of Proposed Transmission Lines

St. Lucie 2 Nuclear (Uprate)

The St. Lucie 2 Nuclear (Uprate) does not require any “new” transmission lines.

Schedule 10
Status Report and Specifications of Proposed Transmission Lines

Turkey Point 4 Nuclear (Uprate)

The Turkey Point 4 Nuclear (Uprate) does not require any “new” transmission lines.

Schedule 10
Status Report and Specifications of Proposed Transmission Lines

Cape Canaveral Next Generation Clean Energy Center (Modernization)

The Cape Canaveral Next Generation Clean Energy Center which will result from the modernization of the Cape Canaveral power plant site does not require any "new" transmission lines.

Schedule 10
Status Report and Specifications of Proposed Transmission Lines

Riviera Beach Next Generation Clean Energy Center (Modernization)

The Riviera Beach Energy Center which will result from the modernization of the Riviera Beach power plant site will require one new line and existing lines to be extended and reconfigured to accommodate the increased capacity.

- | | | |
|-----|--|---|
| (1) | Point of Origin and Termination: | Riviera – Cedar Substation |
| (2) | Number of Lines: | 1 |
| (3) | Right-of-way | Existing, FPL - Owned |
| (4) | Line Length: | 15 miles |
| (5) | Voltage: | 230 kV |
| (6) | Anticipated Construction Timing: | Start date: 2012
End date: 2014 |
| (7) | Anticipated Capital Investment:
(Trans. and Sub.) | \$12,100,000 |
| (8) | Substations: | Riviera Substation and Cedar Substation |
| (9) | Participation with Other Utilities: | None |

Schedule 10
Status Report and Specifications of Proposed Transmission Lines

Port Everglades Next Generation Clean Energy Center

The Port Everglades Next Generation Clean Energy Center which will result from the modernization of the Port Everglades power plant site does not require any “new” transmission lines.

Schedule 11.1

Existing FIRM and NON-FIRM Capacity and Energy by Primary Fuel Type
Actuals for the Year 2011

	(1) Generation by Primary Fuel	(3) Net (MW) Capability				(6) NEL GWh ⁽²⁾	(7) Fuel Mix %
		(2) Summer (MW)	Summer (%)	(4) Winter (MW)	(5) Winter (%)		
(1)	Coal	926	3.8%	928	3.6%	5,634	5.0%
(2)	Nuclear	2,970	12.1%	3,044	11.7%	21,510	19.1%
(3)	Residual	3,672	14.9%	3,706	14.3%	630	0.6%
(4)	Distillate	1,908	7.7%	2,087	8.0%	123	0.1%
(5)	Natural Gas	13,027	52.9%	13,941	53.8%	74,388	66.1%
(6)	Solar	35	0.1%	35	0.1%	71	0.1%
(7)	FPL Existing Units Total⁽¹⁾:	22,538	91.5%	23,741	91.6%	102,356	91.0%
(8)	Renewables (Purchases)- Firm	61.0	0.2%	112.0	0.5%	965	0.9%
(9)	Renewables (Purchases)- Non-Firm	Not Applicable	---	Not Applicable	---	885	0.8%
(10)	Renewable Total:	61.0	0.2%	112.0	0.5%	1,850	1.65%
(11)	Purchases Other :	2,038.0	8.3%	2,074.0	8.0%	8,248	7.3%
(12)	Total:	24,637.0	100.0%	25,927.0	100.0%	112,454	100.0%

Note:

- (1) FPL Existing Units Total values on row (7), columns (2) and (4), match the System Firm Generating Capacity values found on Schedule 1 for Summer and Winter.
- (2) Net Energy for Load GWh values on row (12), column (6), matches Schedule 6.1 value for 2011.

Schedule 11.2

Existing NON-FIRM Self-Service Renewable Generation Facilities
Actuals for the Year 2011

(1) Type of Facility	(2) Installed Capacity DC (MW)	(3) Renewable Projected Annual Output (MWh)	(4) Annual Energy Purchased from FPL (MWh)	(5) Annual Energy Sold to FPL (MWh)	(6) = 3+4-5 Projected Annual Energy Used by Customers (GWh)
Customer-Owned PV (0 kW to 10 kW)	7.3	7,298.5	61,881.5	163.3	69.0
Customer-Owned PV (> 10 kW to 100 kW)	3.5	3,148.1	116,049.8	192.0	119.0
Customer-Owned PV (> 100 kW to 2 MW)	3.3	4,100.1	118,972.0	59.8	123.0
Total:	14.1	14,546.7	296,903.3	415.1	311.0

Notes:

- (1) There were approximately 1,580 customer-owned renewable generation facilities interconnected with FPL on December 31, 2011.
- (2) The Installed Capacity value is the sum of the nameplate ratings (DC MW) for all of the customer-owned renewable generation facilities connected as of Dec. 31, 2011.
- (3) The Projected Annual Output value is based on NREL's PV Watts 1 program and the installed capacity for each customer, adjusted for the days they were actively interconnected during 2011, and assuming each facility operated as planned.
- (4) The Annual Energy Purchased from FPL is an actual value from FPL's metered data for 2011.
- (5) The Annual Energy Sold to FPL is an actual number of kWh credited back to the customer from FPL's metered data for 2011.
- (6) The Projected Annual Energy Used by Customers is a projected value that equals:
Renewable Projected Annual output + Annual Energy Purchased from FPL - Annual Energy Sold to FPL.

(This page is left intentionally blank.)

CHAPTER IV

Environmental and Land Use Information

(This page is left intentionally blank.)

IV. Environmental and Land Use Information

IV.A Protection of the Environment

FPL operates in a sensitive, temperate/sub-tropical environment containing a number of distinct ecosystems with many endangered or threatened plant and animal species. FPL competes for air, land, and water resources that are necessary to meet the demand for generation, transmission, and distribution of electricity. At the same time, residents and tourists want unspoiled natural amenities, and the general public has an expectation that large corporations such as FPL will conduct their business in an environmentally responsible manner.

FPL has been recognized for many years as one of the leaders among electric utilities for its commitment to the environment. For example, FPL has one of the lowest emissions profiles among U.S. utilities and its carbon dioxide (CO₂) emission rate is 36% lower (better) than the industry average. The environmental leadership of FPL and its parent company, NextEra Energy, Inc., has been heralded by many outside organizations as demonstrated by a few recent examples. In 2011, NextEra Energy, Inc. ranked in the top 10 among companies worldwide for social responsibility and, for a record sixth consecutive year, No. 1 in its industry, according to the 2011 "World's Most Admired Companies" report released by Fortune magazine. Being ranked first, for five consecutive years, is unprecedented in the industry and according to *Fortune*, America's Most Admired Companies is "the definitive report card on corporate reputations".

NextEra Energy, Inc. was named to the 2011 Dow Jones Sustainability Index (DJSI) of the leading companies in North America for corporate sustainability for the third consecutive year. The DJSI North America selects the top 20 percent of companies in sustainability performance from the 600 largest companies in North America. According to Sustainable Asset Management, the investment research firm that conducts the DJSI research, the evaluation is continuously adapted to capture the sustainability trends that are at the forefront of each industry sector and are likely to have an impact on the companies' competitive landscape.

FPL was recognized in 2010 by the Southeastern Electric Exchange (SEE) for outstanding performance in constructing the largest photovoltaic (PV) power plant at the time in the United States: the 25 MW DeSoto Next Generation Solar Energy Center. SEE gives its Chairman's Award annually to the project it deems "best of the best" among all

entrants in its 11 award categories. Capable of powering approximately 3,000 homes with renewable energy, the DeSoto PV facility was completed months ahead of schedule and more than \$22 million under budget.

In 2011, FPL's Martin Next Generation Solar Energy Center earned NextEra Energy recognition as a finalist in the competition for the Edison Award, presented annually by EEI. The award for "distinguished leadership, innovation and contribution to the advancement of the electric industry for the benefit of all" is EEI's most prestigious award. Also in 2011, the Martin Next Generation Solar Energy Center was named Project of the Year - Best Renewable Project by Power Engineering magazine, the leading power generation industry publication.

FPL was named a finalist in the Annual Sustainable Florida Best Practice Awards in both 2010 and 2011. In 2010, Sustainable Florida recognized the previously mentioned 25 MW DeSoto PV facility and in 2011 the organization recognized FPL's partnership with Palm Beach County to utilize reclaimed water at the West County Energy Center. The awards were presented by the Council for Sustainable Florida, the premier statewide organization committed to balancing the economic interests of the state with the need to be socially and environmentally responsible. The Sustainable Florida Award recognizes organizations for protecting and preserving Florida's environment for the future while building markets for Florida's businesses.

FPL's responsible tree care practices across its 35-county service area have been recognized for almost a decade. FPL has been the recipient of the Tree Line USA award annually from 2003 - 2011. This award is sponsored by the Arbor Day Foundation in cooperation with the National Association of State Foresters. The recognition is given to utilities that demonstrate quality tree care practices, annual worker training, and public education programs.

In October 2010, FPL won the 2010 Loggerhead Marinelife Center's "Blue Business of the Year" award. The awards were given to those who are leading the way in raising awareness about, and have made significant contributions to improve and protect South Florida's oceans, beaches, and wildlife. The award recognized FPL's protection and conservation of the endangered Florida manatee and fostering public and employee education and support.

IV.B FPL's Environmental Statement

To reaffirm its commitment to conduct business in an environmentally responsible manner, FPL developed an Environmental Statement in 1992 to clearly define its position, which it continues to stand by today. This statement reflects how FPL incorporates environmental values into all aspects of its activities and serves as a framework for new environmental initiatives throughout the company. FPL's Environmental Statement is:

It is the Company's intent to continue to conduct its business in an environmentally responsible manner. Accordingly, Florida Power & Light Company will:

- Comply with the spirit and intent, as well as the letter of, environmental laws, regulations, and standards.
- Incorporate environmental protection and stewardship as an integral part of the design, construction, operation, and maintenance of our facilities.
- Encourage the wise use of energy to minimize the impact on the environment.
- Communicate effectively on environmental issues.
- Conduct periodic self-evaluations and report performance.

IV.C Environmental Management

In order to implement the Environmental Statement, FPL established an Environmental Management System to direct and control the fulfillment of the organization's environmental responsibilities. A key component of the system is an Environmental Assurance Program that is discussed below. Other components include: executive management support and commitment, a dedicated environmental corporate governance program, written environmental policies and procedures, delineation of organizational responsibilities and individual accountabilities, allocation of appropriate resources for environmental compliance management (which includes reporting and corrective action when non-compliance occurs), environmental incident and/or emergency response, environmental risk assessment/management, environmental regulatory development and tracking, and environmental management information systems.

IV.D Environmental Assurance Program

FPL's Environmental Assurance Program consists of activities which are designed to evaluate environmental performance, verify compliance with corporate policy as well as legal and regulatory requirements, and communicate results to corporate management. The principal mechanism for pursuing environmental assurance is the environmental audit. An environmental audit may be defined as a management tool comprising a systematic, documented, periodic, and objective evaluation of the performance of the organization and of the specific management systems and equipment designed to protect the environment. The environmental audit's primary objectives are to facilitate management control of environmental practices and assess compliance with existing environmental regulatory requirements and FPL policies.

IV.E Environmental Communication and Facilitation

FPL is involved in many efforts to enhance environmental protection through the facilitation of environmental awareness and in public education. Some of FPL's 2011 environmental outreach activities are summarized below in Table IV.E.1.

Table IV.E.1: 2011 FPL Environmental Outreach Activities

Activity	# of Participants (Approx.)
Visitors to FPL's Energy Encounter at St. Lucie	12,000
Visitors to Manatee Park	146,814
Number of visits to FPL's Environmental Website	>500,000
Number of pieces of Environmental literature distributed	>20,000
Solar Schools Program (# of schools participating)	1 school and 2 non-profits
Visitors to Barley Barber Swamp	2,955
Number of visits to Manatee Cam Website	66,769

IV.F Preferred and Potential Sites

Based upon its projection of future resource needs, FPL has identified five (5) Preferred Sites and ten (10) Potential Sites for future generation additions. Preferred Sites are

those locations where FPL has conducted significant reviews and has either taken action, or is currently committed to take action, to site new generation capacity. Potential Sites are those sites that have attributes that support the siting of generation and are under consideration as a location for future generation. Some of these sites are currently in use as existing generation sites and some are not. The identification of a Potential Site does not indicate that FPL has made a definitive decision to pursue generation (or generation expansion in the case of an existing generation site) at that location, nor does this designation indicate that the size or technology of a generator has been determined. The Preferred Sites and Potential Sites are discussed in separate sections below.

As has been described in previous FPL Site Plans, FPL also considers a number of other sites as possible sites for future generation additions. These include all of the remainder of FPL's existing generation sites and other Greenfield sites. FPL will continue to analyze the potential for modernizing existing power plant sites such as is now being done at the Cape Canaveral and Riviera sites, and which will occur by 2016 at the existing Port Everglades site. Analyses of any modernization candidates would include evaluation of numerous factors including: fuel delivery, transmission, permitting, etc.

IV.F.1 Preferred Sites

FPL identifies five Preferred Sites and all of them are existing plant sites: the St. Lucie plant site, the Turkey Point plant site, the Cape Canaveral plant site, the Riviera plant site and the Port Everglades plant site.

The St. Lucie site is the location for nuclear capacity uprates that FPL will complete work for in 2012. The Turkey Point site is the location for nuclear capacity uprates that FPL will complete work for in 2012 and 2013. (Turkey Point is also the site for two new nuclear units, Turkey Point Units 6 & 7, for which FPL is pursuing licensing and permit approvals. Current projections for in-service dates for these new nuclear units remain beyond the 2012 through 2021 reporting time frame of this document). The Cape Canaveral, Riviera, and Port Everglades sites are the locations for modernizations of existing power plant sites for capacity additions in 2013, 2014, and 2016, respectively.

The five Preferred Sites are discussed below in general chronological order in regard to when the capacity additions are projected to occur.

Preferred Site # 1: St. Lucie Plant, St. Lucie County

FPL's St. Lucie Plant is located in St. Lucie County on Hutchinson Island on an FPL-owned 1,130-acre site. The plant site is bordered by the Atlantic Ocean to the east and the Indian River Lagoon to the west. Located on the site are two nuclear-powered generating units, St. Lucie Units 1 & 2, which have been in operation since 1976 and 1983, respectively.

The generating capacity addition is an increase in the capacity of the two existing nuclear generating units that is used to serve FPL's customers of approximately 129 MW for St. Lucie Unit 1 and 115 MW for St. Lucie Unit 2. This capacity uprate is referred to as an Extended Power Urate (EPU). The difference between the two values is due to FPL's 100% ownership share of St. Lucie Unit 1 and its 85% ownership share of St. Lucie Unit 2. This work involves changes to several existing main components within the existing facilities to increase their capability to produce steam for the generation of electricity. No new site facilities are required as part of this capacity "uprate." This capacity uprate, along with a similar capacity uprate of FPL's existing Turkey Point nuclear units, was approved by the FPSC in January 2008. A portion (31 MW) of the uprated capacity for St. Lucie Unit 2 has already been implemented and the remainder of the uprated capacity is projected to be in-service by the end of 2012.⁶

a. U.S. Geological Survey (USGS) Map

A USGS map of the FPL St. Lucie Nuclear site is found at the end of this chapter.

b. Proposed Facilities Layout

A map of the general layout of the proposed generating facilities at the site is found at the end of this chapter.

c. Map of Site and Adjacent Areas

An overview map of the site and adjacent areas is also found at the end of this chapter.

d. Existing Land Uses of Site and Adjacent Areas

St. Lucie Units 1 & 2 are pressurized water reactors, each having two steam generators. The prominent structures, enclosed facilities, and equipment associated

⁶ FPL has also been pursuing the addition of six wind turbines at the St. Lucie plant site for a number of years. However, to-date FPL has been unable to obtain the necessary local land use approvals that would first be needed before state and federal approvals could be sought.

with St. Lucie Units 1 & 2 include the containment building, the turbine generator building, the auxiliary building, and the fuel handling building.

Prominent features beyond the power block area include the intake and discharge canals, switchyard, spent-fuel storage facilities, technical and administrative support facilities, and public education facilities (the Energy Encounter and the College of Turtle Knowledge). Significant features surrounding the St. Lucie Units 1 & 2 are predominately undeveloped land and water bodies including; Big Mud Creek, the Atlantic Ocean, Herman's Bay, and Indian River Lagoon.

In regard to the nuclear capacity uprates, the only changes will be modifications to the existing power generation facilities within the power block area, modifications to the switchyard facilities, and modifications to the transmission lines from St. Lucie to Midway substation. None of the other existing facilities at the plant will change as a result of the uprates.

e. General Environment Features On and In the Site Vicinity

1. Natural Environment

FPL's St. Lucie Plant is located in St. Lucie County on Hutchinson Island on an FPL-owned 1,130-acre site. The St. Lucie Plant includes the reactor buildings, turbine buildings, access/security building, auxiliary building, maintenance facilities, and miscellaneous warehouses and other buildings associated with the operation of Units 1 & 2. The site includes adjacent undeveloped mangrove areas. As a result of the capacity uprates, the site characteristics will not change.

2. Listed Species

The construction during the uprating of the units, and operation of the units after the capacity uprating is completed, are not expected to adversely affect any rare, endangered, or threatened species. Some listed species known to occur in the area of the plant location are Atlantic sturgeon (*Acipenser oxyrinchus*), smalltooth sawfish (*Pristis pectinate*), loggerhead sea turtle (*Caretta caretta*), green sea turtle (*Chelonia mydas*), leatherback sea turtle (*Dermochelys coriacea*), hawksbill sea turtle (*Eretmochelys imbricata*), gopher tortoise (*Gopherus polyphemus*), kemp's ridley sea turtle (*Lepidochelys kempî*), wood stork (*Mycteria americana*), black skimmer (*Rynchops niger*), and least tern (*Sterna antillarum*).

No changes in wildlife populations at the adjacent undeveloped areas are anticipated, including listed species. Noise and lighting impacts will not change and it is expected that wildlife will continue to use the undeveloped areas within the St. Lucie Plant boundary.

3. Natural Resources of Regional Significance Status

Significant features surrounding the St. Lucie Units 1 & 2 are predominately undeveloped land and water bodies including; Big Mud Creek, the Atlantic Ocean, Herman's Bay, and Indian River Lagoon.

4. Other Significant Features

FPL is not aware of any other significant features of the site.

f. Design Features and Mitigation Options

The source of cooling water for the St. Lucie Plant is the Atlantic Ocean. The cooling system for the two generating units is a once-through system. The effects of the discharge of cooling water via these discharge structures were evaluated and mixing zones were established to allow compliance with thermal water quality standards as a part of the Plant's NPDES (Permit No. FL0002208). In regard to the nuclear capacity uprates, the once-through cooling system will continue to be used for the nuclear units.

g. Local Government Future Land Use Designations

St. Lucie Units 1 & 2 are located in unincorporated St. Lucie County, Florida. The County has adopted a comprehensive plan, which is updated on a periodic basis. The County Comprehensive Plan incorporates a map that depicts the future land use categories of all property falling within the unincorporated portions of the County. The St. Lucie Plant has a Future Land Use category of Transportation/Utilities (T/U) according to the St. Lucie County Future Land Use Map. The T/U category is described in the St. Lucie County Comprehensive Plan Future Land Use Element Future Land Use.

h. Site Selection Criteria Process

The site has been selected as a Preferred Site for the nuclear capacity uprates because it is an existing nuclear plant site and, therefore, offers the opportunity for increased nuclear capacity.

i. **Water Resources**

The source of cooling water for the St. Lucie Plant is the Atlantic Ocean. The once-through cooling system flow will not change as a result of the nuclear uprates. Due to the existing nature of the St. Lucie Plant, surrounding surface waters will not be adversely affected by the generation capacity addition. Storm water will be handled by the existing facilities and no new areas will be impacted. Wetlands, groundwater, and nearby surface waters will not be impacted.

j. **Geological Features of Site and Adjacent Areas**

Beneath the land surface, there is a peat layer 4 to 6 feet thick. Below this layer is the Anastasia Formation, a sedimentary rock formation composed of clay lenses, sandy limestone, and silty fine to medium sand with fragmented shells. This highly permeable stratum extends 35 to 90 feet below mean sea level (msl). Underlying this stratum there is a semi-permeable zone, The Hawthorn Formation, consisting of slightly clayey and very fine silt which extends 600 feet below msl.

The original surficial deposits at the St. Lucie Plant were excavated to a depth of 60 feet and backfilled with Category I or II fill. The fill is underlain by the Anastasia formation, a sequence of partially cemented sand and sandy limestone, which extends to an average depth of about 145 feet. The Anastasia is underlain to a depth of about 600 to 700 feet by the partially cemented and indurated sands, clays, and sandy limestones of The Hawthorn Formation. Underlying these surface strata are about 13,000 feet of Jurassic through Tertiary Formations, primarily carbonate rocks. These formations have a relatively gentle slope to the southeast.

k. **Projected Water Quantities for Various Uses**

No change is expected in the quantity of industrial wastewaters generated by the facility. Therefore, no change in that compliance achievement status is expected. The capacity uprates will not cause any changes in hydrologic or water quality conditions due to diversion, interception, or additions to surface water flow. The St. Lucie Plant does not directly withdraw groundwater under its current operations and it will not withdraw groundwater after the capacity uprates work is completed. The use of water supplied by the City of Fort Pierce will remain unchanged and there will be no changes to the groundwater discharges. There will be no quality, quantity, or hydrological changes, either by withdrawal or discharge to a drinking water source. Therefore, there will be no impacts on drinking water.

I. Water Supply Sources by Type

The source of cooling water for the St. Lucie Plant is the Atlantic Ocean. General plant service water, fire protection water, process water, and potable water are obtained from City of Fort Pierce. Process water uses include demineralizer regeneration, steam cycle makeup, and general service water use for washdowns. The existing St. Lucie Plant water use is projected to be unchanged as a result of the nuclear capacity uprates.

m. Water Conservation Strategies Under Consideration

The existing water resources will not change as a result of the nuclear capacity uprates.

n. Water Discharges and Pollution Control

St. Lucie Units 1 & 2 use once-through cooling water from the Atlantic Ocean to remove heat from the main (turbine) condensers via the Circulating Water System (CWS), and to remove heat from other auxiliary equipment via the Auxiliary Equipment Cooling Water System (AECWS). The great majority of this cooling water is used for the CWS.

Under emergency conditions, water can be withdrawn from Big Mud Creek via the Emergency Intake Canal through two 54-inch pipe assemblies in the barrier wall that separates the Creek from the Canal. FPL does not use this intake during normal operations, but does test this system quarterly.

The facility employs a Best Management Practices (BMP) plan and Spill Prevention, Control, and Countermeasure (SPCC) plan to control the inadvertent release of pollutants.

o. Fuel Delivery, Storage, Waste Disposal, and Pollution Control

St. Lucie Units 1 & 2 are licensed for uranium-dioxide fuel that is slightly enriched uranium-235. The uranium-dioxide fuel is in the form of pellets contained in Zircaloy tubes with welded end plugs to confine radionuclides. The tubes are fabricated into assemblies designed for loading into the reactor core. Each reactor core includes 217 fuel assemblies.

FPL currently replaces approximately one-third of the fuel assemblies in each reactor at intervals of approximately 18 months. FPL operates the reactors such that the

average fuel usage by the reactors is approximately 47,000 megawatt-days per metric ton uranium. In regard to the nuclear capacity uprates, more nuclear fuel will be used due to the increased capacity of each generating unit. Used fuel assemblies are stored in the onsite Nuclear Regulatory Commission (NRC)-approved spent fuel storage facilities. Following completion of the uprates, approximately 11 percent more nuclear fuel will be used to increase the capacity of each generating unit. No changes in the fuel-handling facilities are required.

Diesel fuel is used in a number of emergency generators that include four main plant generators, two building generators, and various general purpose diesel engines. The main plant emergency generators will not be changed as a result of the generation capacity additions. These emergency generators are for standby use only and are tested to assure reliability and for maintenance. Diesel fuel is delivered to the St. Lucie Plant by truck as needed, and stored in tanks with secondary containment.

p. Air Emissions and Control Systems

The St. Lucie Plant is classified as a minor source of air pollution, since FDEP has issued a Federally Enforceable State Operating Permit (FESOP) to keep emissions less than 100 tons per year for any air pollutant regulated under the Clean Air Act. The applicable units at the St. Lucie Plant consist of eight large main plant diesel engines, two smaller diesel engines, and various general-purpose diesel engines. The air emissions from these engines are limited by the use of 0.05-percent sulfur diesel fuel and good combustion practices. Best Available Control Technology (BACT) is not applicable to these existing emission units.

Nitrogen oxide (NO_x) emissions from the operation of the diesel engines comprise the limiting pollutant for these diesel units at the St Lucie Plant. The FDEP FESOP limits NO_x emissions to 99.4 tons, which includes fuel use limits on the large main plant emergency diesel engines of 97,000 gallons in any 12-month consecutive period and the smaller building and general purpose diesel engines of 190,000 gallons in any 12-month consecutive period. Also, the Plant may choose to combine the diesel units' fuel-tracking which then limits the NO_x totals for a 12-month consecutive period to a maximum of 80 tons. There will be no change in the operation or emissions of the diesel engines resulting from the nuclear capacity uprates.

In addition, the generation capacity additions will not result in an increase of CO₂ or other greenhouse gas emissions. In fact, the increases in emission-free nuclear

generation capacity are projected to result in decreased FPL system-wide emissions of CO₂.

q. Noise Emissions and Control Systems

A field survey and impact assessment of noise expected to be caused by construction activities at the site was conducted. Predicted noise levels are not expected to result in adverse noise impacts in the vicinity of the site during construction or operation.

r. Status of Applications

A Site Certification Application (SCA) under the Florida Electrical Power Plant Siting Act was filed in December 2007 and a final order issued in September 2008. The FPSC voted to approve the need for the St. Lucie (and Turkey Point) nuclear capacity uprates and the final order approving the need for these capacity additions was issued in January 2008.

A License Amendment request for the EPU was submitted to the NRC in November 2010. There are two components to that application; one is the Environmental Assessment (EA) and the other is the Safety component. The St. Lucie Plant EA was published in the Federal Register in January 2012. The Application is still in process.

Preferred Site # 2: Turkey Point Plant, Miami-Dade County

The Turkey Point Plant site is located on the west side of Biscayne Bay, 25 miles south of Miami. The site is directly on the shoreline of Biscayne Bay and is geographically located approximately 9 miles east of Florida City on Palm Drive. Public access to the plant site is limited due to the nuclear units located there. The land surrounding the site is owned by FPL and acts as a buffer zone. The site is comprised of two nuclear units (Units 3 & 4), two natural gas/oil conventional steam units (Units 1 & 2 with Unit 2 currently serving in a synchronous condenser mode to provide voltage support), one CC natural gas unit (Unit 5), nine small diesel generators, the cooling canals, an FPL-maintained natural wildlife area, and wetlands that have been set aside as the Everglades Mitigation Bank (EMB).

Turkey Point Units 3 & 4 have been in operation since 1972 and 1973, respectively. The Turkey Point site has been selected as a Preferred Site for the increase in the capacity of its two existing nuclear generating units by approximately 123 MW each. This capacity uprate is referred to as an Extended Power Uprate (EPU). This work involves changes to

several existing main components within the existing facilities to increase their capability to produce steam for the generation of electricity. No new or expanded facilities are required as part of this capacity “uprate.” This capacity uprate, along with a similar capacity uprate of FPL’s existing St. Lucie nuclear units, was approved by the FPSC in January 2008. The capacity uprates at Turkey Point are projected to be in-service, in part, during 2012 and completely in-service in 2013.

As previously mentioned, FPL is pursuing licensing for two new nuclear units at the Turkey Point site. Each of these two units would provide 1,100 MW of capacity. Current projections for the in-service dates of these two units, Turkey Point Units 6 & 7, remain beyond the 2012 through 2021 reporting time frame of this document.

a. U.S. Geological Survey (USGS) Map

A USGS map of the Turkey Point plant site is found at the end of this chapter.

b. Proposed Facilities Layout

A map of the general layout of the Turkey Point Units 3 and 4 generating facilities at the site is found at the end of this chapter.

c. Map of Site and Adjacent Areas

An overview map of the site and adjacent areas is also found at the end of this chapter.

d. Existing Land Uses of Site and Adjacent Areas

The Turkey Point Plant site is located on the west side of Biscayne Bay, 25 miles south of Miami. The site is directly on the shoreline of Biscayne Bay and is geographically located approximately 9 miles east of Florida City on Palm Drive.

The five existing generating units and support facilities occupy approximately 150 acres of the approximately 11,000-acre Turkey Point Plant site.

Prominent features beyond the power block area include the intake system, cooling canal system, switchyard, spent fuel storage facilities, and technical and administrative support facilities. The cooling canal system occupies approximately 5,900 acres.

The two 400-megawatt (MW) (nominal) fossil fuel-fired steam electric generation units at the Turkey Point Plant have been in service since 1967 (Unit 1) and 1968

(Unit 2). These units have historically burned residual fuel oil and/or natural gas with a maximum equivalent sulfur content of 1 percent. Unit 2 is currently serving, not as a power generating unit, but as a synchronous condenser to provide voltage support to the southeastern end of FPL's transmission system. The two 700-MW (nominal) nuclear units have been in service since 1972 (Unit 3) and 1973 (Unit 4). Turkey Point Units 3 and 4 are pressurized water reactor (PWR) units. Turkey Point Unit 5 is a nominal 1,150-MW natural gas-fired combined cycle (CC) unit that began operation in 2007. Significant features in the vicinity of the site include Biscayne National Park, the Miami-Dade County Homestead Bayfront Park, and the Everglades National Park.

e. General Environment Features On and In the Site Vicinity

1. Natural Environment

The Turkey Point Plant site is located on the west side of Biscayne Bay, 25 miles south of Miami. The site is directly on the shoreline of Biscayne Bay and is geographically located approximately 9 miles east of Florida City on Palm Drive. The Turkey Point Plant includes the reactor buildings, turbine buildings, access/security building, auxiliary building, maintenance facilities, and miscellaneous warehouses and other buildings associated with the operation of Units 3 & 4. As a result of the approved capacity uprates, the site characteristics will not change.

2. Listed Species

The construction during the uprating of the units, and operation of the units after the capacity uprating is completed, are not expected to adversely affect any rare, endangered, or threatened species. Some listed species known to occur at the site and in the nearby Biscayne National Park that could potentially utilize the site include the peregrine falcon (*Falco peregrinus*), wood stork (*Mycteria americana*), American crocodile (*Crocodylus acutus*), mangrove rivulus (*Rivulus marmoratus*), roseate spoonbill (*Ajaja ajaja*), limpkin (*Aramus guarauna*), little blue heron (*Egretta caerulea*), snowy egret (*Egretta thula*), American oystercatcher (*Haematopus palliatus*), least tern (*Sterna antillarum*), the white ibis (*Eudocimus albus*), and bald eagle (*Haliaeetus leucocephalus*). No bald eagle nests are known to exist in the vicinity of the site. The federally listed, threatened American Crocodile thrives at the Turkey Point site, primarily in and around the southern end of the cooling canals which lie south of the project area.

The entire site is considered crocodile habitat due to the mobility of the species and use of the site for foraging, traversing, and basking. FPL manages a program for the conservation and enhancement of the American Crocodile which is attributed with survival improvement and the downlisting of the American Crocodile from endangered to threatened.

3. Natural Resources of Regional Significance Status

Significant features in the vicinity of the site include Biscayne National Park, the Miami-Dade County Homestead Bayfront Park, and the Everglades National Park. The portion of Biscayne Bay adjacent to the site is included within the Biscayne National Park. Biscayne National Park contains 180,000 acres, approximately 95 percent of which is open water interspersed with more than 40 keys. The Biscayne National Park headquarters is located approximately 2 miles north of the Turkey Point Plant and is adjacent to the Miami-Dade County Homestead Bayfront Park which contains a marina and day-use recreational facilities.

4. Other Significant Features

FPL is not aware of any other significant features of the site.

f. Design Features and Mitigation Options

Turkey Point Units 3 & 4 uses cooling water from a closed-cycle cooling canal system to remove heat from the main (turbine) condensers, and to remove heat from other auxiliary equipment. The existing cooling canals will accommodate the increase in heat load that is associated with the increased capacity from the uprates. The maximum projected increase in water temperature entering the cooling canal system from the units resulting from the uprates is predicted to be about 2.5°F, from 106.1°F to 108.6°F. The associated projected maximum increase in water temperature returning to the units is about 0.9°F, from 91.9°F to 92.8°F.

g. Local Government future Land Use Designations

Local government future land use plan designates most of the site as IU-3 "(Industrial, Utilities, and Communications) Unlimited Manufacturing District." There are also areas designated GU – "Interim District." Designations for the surrounding area are primarily GU – "Interim District."

h. Site Selection Criteria Process

The site has been selected as a Preferred Site for the nuclear capacity uprates because it is an existing nuclear plant site and, therefore, offers the opportunity for increased nuclear capacity.

i. Water Resources

Unique to the Turkey Point Plant site is the self-contained cooling canal system that supplies water to condense steam used by the plant's turbine generators. The canal system consists of 36 interconnected canals. The cooling canals occupy an area approximately two miles wide by five miles long (5,900 acres), approximately four feet deep. The system performs the same function as a giant radiator. The water is circulated through the canals in a two-day journey, ending at the plant's intake pumps.

j. Geological Features of Site and Adjacent Areas

The Turkey Point Plant lies upon the Floridian Plateau, a partly-submerged peninsula of the continental shelf. The peninsula is underlain by approximately 4,000 to 15,000 feet of sedimentary rocks consisting of limestone and associated formations that range in age from Paleozoic to Recent. Little is known about the basement complex of Paleozoic igneous and metamorphic rocks due to their great depth.

Generally in Miami-Dade County, the surficial aquifer (Biscayne Aquifer) consists of a wedge-shaped system of porous clastic and carbonate sedimentary materials, primarily limestone and sand deposits of the Miocene to late Quaternary age. The Biscayne Aquifer is thickest along the eastern coast and varies in thickness from 80 to 200 feet thick. The surficial aquifer is typically composed of Pamlico Sand, Miami Limestone (Oolite), the Fort Thompson and Anastasia Formations (lateral equivalents), Caloosahatchee Marl, and the Tamiami formation. The lower confining layers below the surficial aquifer range in thickness from 350 to 600 feet and are composed of the Hawthorn Group. Beneath the Hawthorn Group, the Floridan Aquifer System ranges from 2,800 to 3,400 feet thick and consists of Suwannee Limestone, Avon Park Limestone, and the Oldsmar Formations.

k. Projected Water Quantities for Various Uses

The addition of nuclear generating capacity as a result of the uprates will not cause any changes in the quantity or characteristics of industrial wastewaters generated by the facility; therefore, no change in that compliance achievement status is expected.

The uprates will not cause any changes in hydrologic or water quality conditions due to diversion, interception, or additions to surface water flow. The Turkey Point Nuclear Plant does not directly withdraw groundwater under its current operations and it will not do so after the capacity uprates. Locally, groundwater is present beneath the site in the surficial or Biscayne Aquifer and in deeper aquifer zones that are part of the Floridan Aquifer System. There will be no effects on those deeper aquifer zones from the capacity uprates.

I. Water Supply Sources and Type

The source of cooling water for Turkey Point Units 3 & 4 is the cooling canal system. There will be no increase in the amount of water withdrawn as a result of the capacity uprates. General plant service water, fire protection water, process water, and potable water are obtained from Miami-Dade County. Process water uses include demineralizer regeneration, steam cycle makeup, and general service water use for washdowns. The water use for the facility will not change as a result of the capacity uprates.

m. Water Conservation Strategies

The existing water resources will not change as a result of the nuclear capacity uprates.

n. Water Discharges and Pollution Control

Heated water discharges are dissipated using the existing closed cooling canal system.

The facility employs a Best Management Practices (BMP) plan and Spill Prevention, Control, and Countermeasure (SPCC) plan to prevent and control the inadvertent release of pollutants.

o. Fuel Delivery, Storage, Waste Disposal, and Pollution Control

Turkey Point Units 3 & 4 utilize uranium-dioxide fuel that is slightly enriched uranium-235. The uranium-dioxide fuel is in the form of pellets contained in Zircaloy tubes with welded end plugs to confine radionuclides. The tubes are fabricated into assemblies designed for loading into the reactor core. Used fuel assemblies are stored in the onsite NRC-approved spent fuel storage facilities.

FPL currently replaces approximately one-third of the fuel assemblies in each reactor at refueling intervals of approximately 18 months. FPL operates the reactors such that the average fuel usage by the reactors is approximately 45,000 megawatt-days per metric ton of uranium. Following completion of the uprates, more nuclear fuel will be used to increase the capacity of each unit. No changes in the fuel handling facilities are required. Following completion of the uprates, approximately 11 percent more nuclear fuel will be used to increase the capacity of each unit. No changes in the fuel-handling facilities are required.

Diesel fuel is used in a number of emergency generators that include four main emergency generators, five smaller emergency generators, and various general purpose diesel engines. The emergency generators will not be changed as a result of the capacity uprates. These emergency generators are for stand-by use only and only operated for testing purposes to assure reliability and for maintenance. Diesel fuel for the emergency generators is delivered to the Turkey Point Plant by truck as needed, and stored in tanks with secondary containment.

p. Air Emissions and Control Systems

The normal operation of Turkey Point Units 3 & 4 does not create fossil fuel-related air emissions. However, there are nine emergency generators associated with Units 3 & 4. Four of these nine emergency generators are main plant emergency generators which are rated at 2.5 MW each. The remaining five generators are smaller emergency generators which are associated with the security system. In addition, various general purpose diesels are used as needed for Units 3 & 4.

Turkey Point Plant Units 3 & 4's associated emergency generators and diesel engines, together with Units 1, 2, & 5, are classified as a major source of air pollution. FDEP has issued a separate Title V Air Operating Permit for the Turkey Point Nuclear Plant (Permit Number 0250003-004-AV). There are no operating limits for the emergency generators or diesel engines. Emergency diesel generators are limited to ultra-low sulfur distillate (0.0015% sulfur). NO_x emissions are regulated under Reasonably Available Control Technology (RACT) requirements in Rule 62-296.570(4)(b)7 F.A.C., which limit NO_x emissions to 4.75 lb/MMBtu. The use of 0.05 percent sulfur diesel fuel and good combustion practices serve to keep NO_x emissions under this limit.

q. Noise Emissions and Control Systems

A field survey and impact assessment of noise expected to be caused by activities associated with the uprates was conducted. Predicted noise levels are not expected to result in adverse noise impacts in the vicinity of the site.

r. Status of Applications

A Site Certification Application (SCA) under the Florida Electrical Power Plant Siting Act was filed in January 2008 and a final order was issued in October 2008. The FPSC voted to approve the need for the Turkey Point (and St. Lucie) uprates and the final order approving the need for this additional nuclear capacity was issued in January 2008.

A License Amendment request for the EPU was submitted to the NRC in October 2010. There are two components to that application; one is the Environmental Assessment (EA) and the other is the Safety component. The Turkey Point Plant EA was published in the Federal Register in November 2011. The Application is still in process.

Preferred Site # 3: Cape Canaveral Plant, Brevard County

This site is located on the existing FPL Cape Canaveral Plant property in unincorporated Brevard County. The site is bound to the east by the Indian River Lagoon and on the west by a four lane highway (US. 1). The city of Port St. Johns is located less than a mile away. A rail line is located near the plant.

The site previously housed two steam generating units (Units 1 & 2) with 788 MW (Summer) of generating capacity. The units formerly occupied a portion of the 43 acres that are wholly owned by FPL. FPL is in the process of modernizing the existing Cape Canaveral Plant, to be renamed the Cape Canaveral Next Generation Clean Energy Center (CCEC), by replacing the previous two steam generating units with a single modern, highly efficient, lower-emission next-generation clean energy center using advanced combined cycle (CC) technology. The old units have been taken out of service. The demolition of the Cape Canaveral Plant began in mid-2010 and was completed during the first quarter of 2011. Construction for the new CC unit began in March 2011 and is expected to be completed by June 2013.

a. **Geological Survey (USGS) Map**

A USGS map of the CCEC site is found at the end of this chapter.

b. **Proposed Facilities Layout**

A map of the general layout of the CCEC generating facilities at the site is found at the end of this chapter.

c. **Map of Site and Adjacent Areas**

An overview map of the site and adjacent areas is also found at the end of this chapter.

d. **Existing Land Uses of Site and Adjacent Areas**

The existing and future land uses on the site are primarily dedicated to electrical generation; i.e., FPL's former Cape Canaveral Units 1 & 2 and the future CCEC unit. The existing land uses that are adjacent to the site consist of single- and multi-family residences to the south and southwest, commercial property to the northwest, utility systems to the west, and a private medical/office facility to the north.

e. **General Environment Features On and In the Site Vicinity**

1. **Natural Environment**

The natural environment surrounding the site includes the Indian River Lagoon to the east and upland scrub, pine and hardwoods to the north and south. Vegetation with the approximately 45-acre offsite construction laydown and parking area (located west of U.S. Highway 1) consists of open land, upland scrub, pine, hardwoods along with exotic plant species.

2. **Listed Species**

No adverse impacts to federally or state-listed terrestrial plants and animals are expected in association with construction at the site, due to the existing developed nature of the site and lack of suitable onsite habitat for listed species. Federal- or state-listed terrestrial plants and animals inhabiting the offsite construction laydown and parking area are limited to the state-listed gopher tortoise and the state- and federally-listed scrub jay. The warm water discharges from the plant attract manatees, an endangered species. FPL continues to work closely with state and federal wildlife agencies to ensure protection of the manatees during the modernization process. In 2010, FPL installed a temporary

heating system to warm the water for the manatees as required during manatee season. FPL has complied, and will continue to comply, with several other manatee-related conditions of certification to ensure the protection of the manatees during the modernization work and during subsequent operation of the new generating facility.

3. Natural Resources of Regional Significance Status

The construction and operation of a natural gas-fired CC generating facility at this location is consistent with the existing use at the site and is not expected to have any adverse impacts on parks, recreation areas, or environmentally sensitive lands.

4. Other Significant Features

FPL is not aware of any other significant features of the site.

f. Design Features and Mitigation Options

The design option is to replace the previous steam generating units (Units 1 & 2) with one new 1,210 MW (approximate) CC unit consisting of three new combustion turbines (CT), three new heat recovery steam generators (HRSG), and a new steam turbine. The new CC unit is projected to be in-service in mid-2013. Natural gas delivered via pipeline is the primary fuel type for this unit with ULSD serving as a backup fuel.

g. Local Government Future Land Use Designations

Local government future land use designation for the site is "Public Utilities" and the area has been rezoned to GML-U. Designations for the surrounding area are primarily "Community Commercial" and "Residential". A land use map of the site and adjacent areas is also found at the end of this chapter.

h. Site Selection Criteria Process

The Cape Canaveral Plant site was selected for a site modernization due to consideration of various factors including system load and economics. Environmental issues were not a deciding factor since this site does not exhibit significant environmental sensitivity or other environmental issues. However, the significant reduction in cooling water withdrawal and thermal component of cooling water discharges are environmental benefits of replacing the previous steam units with a new CC unit including a significant reduction in system fuel use, a significant

reduction in system air emissions, improved aesthetics at the site, and continued warm water discharge for the manatees as required during manatee season. Further, modernizing this existing facility reduces the impact on natural resources by not requiring new land, new water sources, or additional off-site transmission siting.

i. Water Resources

Condenser cooling for the steam cycle portion of the new plant and auxiliary cooling will come from the existing cooling water intake system. Process, potable, and reclaimed water for the new plant will come from the existing City of Cocoa's potable water supply.

j. Geological Features of Site and Adjacent Areas

The site is located on the Atlantic Coastal Ridge and is at an approximate elevation of 12 feet above mean sea level (msl). The land consists primarily of fine to medium sand that parallels the coast. There is a lack of shell as it was deposited during a time of transgression. The base of the sedimentary rocks is made up of a thick, primarily carbonate sequence deposited during the Jurassic age through the Pleistocene age. Starting in the Miocene age and continuing through the Holocene age, siliciclastic sedimentation became more predominant. The basement rocks in this area consist of low-grade metamorphic and igneous intrusives, which occur several thousand feet below land surface and are Precambrian, Paleozoic, and Mesozoic in age.

k. Projected Water Quantities for Various Uses

The estimated quantity of water required for processing is approximately 0.232 million gallons per day (mgd) for uses such as process water and service water. Approximately 619 mgd of cooling water would be cycled through the once-through cooling water system. Potable water demand is expected to average .001 mgd.

l. Water Supply Sources by Type

The modernized plant will continue to use the Indian River Lagoon water as the source of once-through cooling water. Such needs for cooling water will comply with the St. John's River Water Management District (SJRWMD) conditions of certification. Process and potable water for the new plant will come from the existing City of Cocoa's potable water supply. Reclaimed water will be used for irrigation.

m. Water Conservation Strategies Under Consideration

No additional water resources will be required as a result of the modernization project. Combined cycle technology uses less water by design than traditional steam generation units.

n. Water Discharges and Pollution Control

The modernized site will utilize portions of the existing once-through cooling water systems for heat dissipation. The heat recovery steam generator blowdown will be reused to the maximum extent practicable or mixed with the cooling water flow before discharge. Reverse osmosis (R/O) reject will be mixed with the plant's once-through cooling water system. Storm water runoff will be collected and routed to storm water ponds. The facility will employ a Best Management Practices (BMP) plan and Spill Prevention, Control, and Countermeasure (SPCC) plan to prevent and control the inadvertent release of pollutants.

o. Fuel Delivery, Storage, Waste Disposal, and Pollution Control

Natural gas for the new unit will be transported to the site via a pipeline. New off-site or on-site gas compressors will be installed to raise the gas pressure of the existing pipeline for the new unit. ULSD "light oil" will be received by truck or barge from Port Canaveral and stored in an above-ground storage tank.

p. Air Emissions and Control Systems

The emission rates of CCEC would decrease by over 90% from the former Cape Canaveral Plant, resulting in substantial annual emission reductions and increased air quality benefits per unit of energy produced. The use of natural gas, ULSD, and combustion controls would minimize air emissions from the unit and ensure compliance with applicable emission limiting standards. Using these fuels minimizes emissions of sulfur dioxide (SO₂), particulate matter, and other fuel-bound contaminants. Combustion controls similarly minimize the formation of nitrogen oxides (NO_x) and the combustor design will limit the formation of carbon monoxide and volatile organic compounds. When firing natural gas, NO_x emissions will be controlled using dry-low NO_x combustion technology and selective catalytic reduction (SCR). Water injection and SCR will be used to reduce NO_x emissions during operations when using ULSD as backup fuel. These design alternatives are equivalent to the Best Available Control Technology for air emissions, and minimize such emissions while balancing economic, environmental, and energy impacts. In

total, the design of the new CCEC plant will incorporate features that would make it among the most efficient and cleanest power plants in the State of Florida.

q. Noise Emissions and Control Systems

Noise from the operation of the new unit will be within allowable levels.

r. Status of Applications

The FPSC voted to approve the need for the modernization project and the need order was issued in September 2008. The project received final state certification on October 9, 2009, through the issuance of a final order signed by the Secretary of the Department of Environmental Protection (DEP).

Preferred Site # 4: Riviera Plant, Palm Beach County

This site is located on the former FPL Riviera Plant property primarily within Riviera Beach, Palm Beach County (with a small portion of the Site in West Palm Beach). The site is bound to the east by the Lake Worth Lagoon (Intracoastal Waterway) and on the west by a four lane highway (US. 1). The site has barge access via the Port of Palm Beach. A rail line is located near the plant.

The previous site generating capacity was made up of two 300 MW (approximate) steam generating units (Units 3 & 4) that have been taken out of service and dismantled in 2011. Units 1 & 2 were previously retired and dismantled and are no longer on the plant site.

FPL is in the process of modernizing the former Riviera Plant, to be renamed the Riviera Beach Next Generation Clean Energy Center (RBEC), by replacing the existing generating units with a modern, highly efficient, lower-emission next-generation clean energy center using advanced CC technology.

a. U.S. Geological Survey (USGS) Map

A USGS map of the RBEC site is found at the end of this chapter.

b. Proposed Facilities Layout

A general layout of the RBEC generating facilities is found at the end of this chapter.

c. Map of Site and Adjacent Areas

An overview map of the site and adjacent areas is also found at the end of this chapter.

d. Existing Land Uses of Site and Adjacent Areas

The previous Riviera Plant consisted of two 300 MW (approximate) units with conventional dual-fuel fired steam boilers and steam turbine units. The plant site includes minimal vegetation and a landscape buffer area south of the power plant. Adjacent land uses include port facilities and associated industrial activities, as well as light commercial and residential development.

e. General Environment Features On and In the Site Vicinity

1. Natural Environment

The majority of the site is comprised of facilities related to electric power generation. The site is located adjacent to the Intracoastal Waterway. The site provides warm water as required for manatees pursuant to the facility's Manatee Protection Plan.

2. Listed Species

No adverse impacts to federally or state-listed terrestrial plants and animals are expected in association with construction at the site, due to the existing developed nature of the site and lack of suitable onsite habitat for listed species. The warm water discharges from the plant attract manatees, an endangered species. FPL continues to work closely with state and federal wildlife agencies to ensure protection of the manatees during the modernization process. In 2009, FPL installed a temporary heating system to warm the water for the manatees as required pursuant to the facility's Manatee Protection Plan. FPL will also be complying with several other manatee-related conditions of certification to ensure the protection of the manatees during the modernization work and during operation of the RBEC.

3. Natural Resources of Regional Significance Status

The construction and operation of a natural gas-fired CC generating facility at this location is consistent with the existing use at the site and is not expected to have any adverse impacts on parks, recreation areas, or environmentally sensitive lands.

4. Other Significant Features

FPL is not aware of any other significant features of the site.

f. Design Features and Mitigation Options

The design option is to replace the previous steam generating units (Units 3 & 4) with one new 1,212 MW (approximate) CC unit consisting of three new combustion turbines (CT), three new heat recovery steam generators (HRSG), and a new steam turbine. The new CC unit is projected to be in service in mid-2014. Natural gas delivered via pipeline is the primary fuel type for the unit with ULSD serving as a backup fuel.

g. Local Government Future Land Use Designations

Local government future land use designation for the site is "Utility". The Port of Palm Beach is to the north of the site. Designation to the west of the site is "Commercial." To the south of the site is "Residential" and is in the City of West Palm Beach. A land use map of the site and adjacent areas is also found at the end of this chapter.

h. Site Selection Criteria Process

This site has been selected for site modernization due to consideration of various factors including system load and economics. Environmental issues were not a deciding factor since this site does not exhibit significant environmental sensitivity or other environmental issues. However, there are environmental benefits of replacing the existing steam units with a new CC unit including a significant reduction in system air emissions, improved aesthetics at the site, and continued warm water discharge for the manatees as required during manatee season. Further, modernizing this existing facility reduces the impact on natural resources by not requiring new land or new water resources.

i. Water Resources

Water from the Lake Worth Lagoon (Intracoastal Waterway) will be used for once-through cooling water. RBEC will utilize portions of the existing once-through cooling water intake and discharge structures. Water for cooling pump seals and irrigation will come from three onsite surficial aquifer wells. Process and potable water for the converted plant will come from the existing City of Riviera Beach potable water supply.

j. Geological Features of Site and Adjacent Areas

The site is underlain by the surficial aquifer system. The surficial aquifer system in eastern Palm Beach County is primarily composed of sand, sandstone, shell, silt, calcareous clay (marl), and limestone deposited during the Pleistocene and Pliocene Epochs. The sediments forming the aquifer system are the Pamlico Sand, Fort Thompson Formation (Pleistocene) and the Caloosahatchee Marl (Pleistocene and Pliocene). Permeable sediments in the upper part of the Tamiami Formation (Pliocene) are also part of the aquifer system.

The surficial aquifer is underlain by at least 600 feet the Hawthorn formation (confining unit). The Floridan Aquifer System underlies the Hawthorn formation.

k. Projected Water Quantities for Various Uses

The estimated quantity of water required for processing is approximately 0.232 million gallons per day (mgd) for uses such as process water and service water. Approximately 600 mgd of cooling water would be cycled through the once-through cooling water system. Potable water demand is expected to average .001 mgd.

l. Water Supply Sources by Type

The modernized plant will continue to use Lake Worth Lagoon water as the source of once-through cooling water. Water for cooling pump seals and irrigation will come from on-site surficial aquifer wells currently authorized under SFWMD conditions of certification. Process and potable water for the new plant will come from the existing City of Riviera Beach's potable water supply.

m. Water Conservation Strategies Under Consideration

No additional water resources will be required as a result of the modernization project. Combined cycle technology uses less water by design than traditional steam generation units.

n. Water Discharges and Pollution Control

The modernized plant will utilize portions of the existing once-through cooling water system for heat dissipation. The heat recovery steam generator blowdown will be mixed with the cooling water flow before discharge. Reverse osmosis (R/O) reject will be mixed with the plant's once-through cooling water system prior to discharge. Storm water runoff will be collected and routed to storm water ponds. The facility will employ a Best Management Practices (BMP) plan and Spill Prevention, Control, and

Countermeasure (SPCC) plan to prevent and control the inadvertent release of pollutants.

o. Fuel Delivery, Storage, Waste Disposal, and Pollution Control

Natural gas for the new unit would be transported to the site via an approximately 6 mile FPL-owned pipeline, the RBEC Lateral. New gas compressors will be installed at the existing FPL 45th Street Terminal facility in Riviera Beach to raise the gas pressure of the pipeline to the appropriate level for the new unit. ULSD would be received by truck, pipeline, or barge and stored in a new above-ground storage tank.

p. Air Emissions and Control Systems

The regulated air emission rates at the new plant would be more than 90 percent lower than the previous Riviera Plant's emission rates, resulting in significant annual emissions reductions and air quality benefits per unit of energy produced. The use of natural gas and ULSD and combustion controls would minimize air emissions from the unit and ensure compliance with applicable emission limiting standards. Using these fuels minimizes emissions of sulfur dioxide (SO₂), particulate matter, and other fuel-bound contaminants. Combustion controls similarly minimize the formation of nitrogen oxides (NO_x) and the combustor design will limit the formation of carbon monoxide and volatile organic compounds. When firing natural gas, NO_x emissions will be controlled using dry-low NO_x combustion technology and selective catalytic reduction (SCR). Water injection and SCR will be used to reduce NO_x emissions during operations when using ULSD as backup fuel. These design alternatives are equivalent to the Best Available Control Technology for air emissions, and minimize such emissions while balancing economic, environmental, and energy impacts. Taken together, the design of RBEC would incorporate features that will make it among the most efficient and cleanest power plants in the State of Florida.

q. Noise Emissions and Control Systems

Noise expected to be caused by unit construction at the site is expected to be below current noise levels for the residents nearest the site.

r. Status of Applications

The FPSC voted to approve the need for the modernization project and the need order was issued in September 2008. The project received final state certification on November 24, 2009, through the issuance of a final order signed by the Secretary of

the DEP. The project received final certification for the RBEC 6 mile pipeline lateral and compressor station on March 15, 2011.

Preferred Site # 5: Port Everglades, Broward County

This site is located on the existing FPL Port Everglades Plant property within the City of Hollywood, Broward County. The site is surrounded by the Port of Port Everglades. The site has barge access via the Port of Port Everglades. A rail line is located near the plant.

The previous site generating capacity was made up of two 200 MW (approximate) steam generating units (Units 1 & 2) and two 400 MW (approximate) steam generating units (Units 3 & 4). The four units are proposed to be taken out of service and dismantled in 2013 as part of the modernization of the plant site.

The Port Everglades Plant site has been listed as a Potential Site in previous FPL Site Plans for both CC and simple cycle combustion turbine (CT) generation options. On March 27, 2012, the FPSC voted to authorized the modernization of the existing Port Everglades Plant. As a result of the modernization of the site, the new generating unit - to be renamed the Port Everglades Next Generation Clean Energy Center (PEEC) – will replace the existing steam generating units with a modern, highly efficient, lower-emission next-generation clean energy center using advanced CC technology. The existing four steam units will first be removed from the site and will be replaced by a single new CC unit.

a. **U.S. Geological Survey (USGS) Map**

A USGS map of the PEEC site is found at the end of this chapter.

b. **Proposed Facilities Layout**

A general layout of the PEEC generating facilities is found at the end of this chapter.

c. **Map of Site and Adjacent Areas**

An overview map of the site and adjacent areas is also found at the end of this chapter.

d. **Existing Land Uses of Site and Adjacent Areas**

The existing Port Everglades Plant consists of two 200 MW (approximate) and two 400 MW (approximate) generating units with conventional dual-fuel fired steam

boilers and steam turbine units. The plant site includes minimal vegetation. Adjacent land uses include port facilities and associated industrial activities, as well as light commercial and residential development.

e. **General Environment Features On and In the Site Vicinity**

1. **Natural Environment**

The majority of the site is comprised of facilities related to electric power generation for the existing Port Everglades Plant generating units. The site is located adjacent to the Intracoastal Waterway. The site provides warm water as required for manatees pursuant to the facility's Manatee Protection Plan.

2. **Listed Species**

No adverse impacts to federally or state-listed terrestrial plants and animals are expected in association with construction at the site, due to the existing developed nature of the site and lack of suitable onsite habitat for listed species. The warm water discharges from the plant attract manatees, an endangered species. FPL continues to work closely with state and federal wildlife agencies to ensure protection of the manatees during the modernization process and upon operation of the new plant. FPL plans to install a temporary heating system to provide warm water for manatees as required pursuant to the facility's Manatee Protection Plan. FPL also anticipates complying with other manatee-related conditions of certification to ensure the protection of the manatees during the modernization work and during future operations of PEEC.

3. **Natural Resources of Regional Significance Status**

The construction and operation of a natural gas-fired CC generating facility at this location is consistent with the existing use at the site and is not expected to have any adverse impacts on parks, recreation areas, or environmentally sensitive lands.

4. **Other Significant Features**

FPL is not aware of any other significant features of the site.

f. **Design Features and Mitigation Options**

The design option is to replace the existing units (Units 1 through 4) with one new 1,277 MW (approximate) unit consisting of three new combustion turbines (CT), three

new heat recovery steam generators (HRSG), and a new steam turbine. The new CC unit is projected to be in service in mid-2016. Natural gas delivered via the existing pipeline is the primary fuel type for the unit with ULSD serving as a backup fuel.

g. Local Government Future Land Use Designations

Local government future land use designation for the site is a combination of “Electrical Generating Facility” and “Utilities Use”. A land use map of the site and adjacent areas is also found at the end of this chapter.

h. Site Selection Criteria Process

The Port Everglades Plant has been selected for site modernization due to consideration of various factors including system load, ability to provide generation in the Miami-Dade/Broward region to help balance load and generation in the region, and economics. Environmental issues were not a deciding factor since this site does not exhibit significant environmental sensitivity or other environmental issues. However, there are environmental benefits of replacing the existing steam units with a new CC unit including a significant reduction in system air emissions, improved aesthetics at the site, and continued warm water discharge for the manatees as required pursuant to the facility’s Manatee Protection Plan. Further, modernizing this existing facility reduces the impact on natural resources by not requiring new land or new water resources.

i. Water Resources

Water from the Intracoastal Waterway via the Port of Port Everglades Slip No. 3 is currently used for once-through cooling water supply. The new plant will utilize portions of the existing once-through cooling water intake and discharge structures. Process and potable water for the modernized plant will come from the existing City of Ft. Lauderdale potable water supply.

j. Geological Features of Site and Adjacent Areas

FPL’s Port Everglades Plant site is underlain by the surficial aquifer system. The surficial aquifer system in eastern Broward County is primarily composed of sand, sandstone, shell, silt, calcareous clay (marl), and limestone deposited during the Pleistocene and Pliocene ages. The sediments forming the aquifer system are the Pamlico Sand, Miami Oolite, Anastasia Formation, Key Largo Formation, and Fort Thompson Formation (Pleistocene) and the Tamiami Formation (Pliocene). The

sediments in the eastern portion of the county are appreciably more permeable than in the west.

The surficial aquifer is underlain by at least 600 feet the Hawthorn formation (confining unit). The Floridan Aquifer System underlies the Hawthorn formation.

k. Projected Water Quantities for Various Uses

The estimated quantity of water required for processing is approximately 0.24 million gallons per day (mgd) for uses such as process water and service water. Approximately 635 mgd of cooling water would be cycled through the once-through cooling water system. Potable water demand is expected to average .001 mgd.

l. Water Supply Sources by Type

The modernized plant will continue to use the Intracoastal Waterway as the source of once-through cooling water. Process and potable water for the new plant will come from the existing City of Ft. Lauderdale potable water supply.

m. Water Conservation Strategies Under Consideration

No additional water resources will be required as a result of the modernization project. Combined cycle technology uses less water by design than traditional steam generation units.

n. Water Discharges and Pollution Control

The modernized plant will utilize portions of the existing once-through cooling water system for heat dissipation. The heat recovery steam generator blowdown will be reused to the maximum extent practicable or mixed with the cooling water flow before discharge. Reverse osmosis (R/O) reject will be mixed with the plant's once-through cooling water system prior to discharge. Stormwater runoff will be collected and routed to stormwater ponds. The facility will employ a Best Management Practices (BMP) plan and Spill Prevention, Control, and Countermeasure (SPCC) plan to prevent and control the inadvertent release of pollutants.

o. Fuel Delivery, Storage, Waste Disposal, and Pollution Control

Natural gas for the new unit would be transported to the site via an existing natural gas pipeline to the site. New gas compressors to raise the gas pressure of the pipeline to the appropriate level for the new unit will be installed either at the existing

site or off-site. ULSD would be received by truck, pipeline, or barge and stored in a new above-ground storage tank.

p. Air Emissions and Control Systems

The regulated air emission rates at the new plant would be approximately 90 percent lower than the previous Port Everglades Plant's emission rates, resulting in significant annual emissions reductions and air quality benefits per unit of energy produced. The use of natural gas and ULSD and combustion controls would minimize air emissions from the unit and ensure compliance with applicable emission limiting standards. Using these fuels minimizes emissions of sulfur dioxide (SO₂), particulate matter, and other fuel-bound contaminants.

Combustion controls similarly minimize the formation of nitrogen oxides (NO_x) and the combustor design will limit the formation of carbon monoxide and volatile organic compounds. When firing natural gas, NO_x emissions will be controlled using dry-low NO_x combustion technology and selective catalytic reduction (SCR). Water injection and SCR will be used to reduce NO_x emissions during operations when using ULSD as backup fuel. These design alternatives are equivalent to the Best Available Control Technology for air emissions, and minimize such emissions while balancing economic, environmental, and energy impacts. Taken together, the design of PEEC would incorporate features that will make it among the most efficient and cleanest power plants in the State of Florida.

q. Noise Emissions and Control Systems

Noise expected to be caused by unit construction at the site is expected to be below current noise levels for the residents nearest the site.

r. Status of Applications

FPL filed a need determination with the FPSC on November 21, 2011. The FPSC authorized the need for the modernization of Port Everglades on March 27, 2012. The Site Certification Application (SCA) was submitted January 24, 2012. Concurrent with the SCA filing, FPL submitted applications for a Prevention of Significant Deterioration permit and an Industrial Wastewater Facility permit revision.

IV.F.2 Potential Sites for Generating Options

Ten (10) sites are currently identified as Potential Sites for near-term future generation additions to meet FPL's projected capacity and energy needs.⁷ These sites have been identified as Potential Sites due to considerations of location to FPL load centers, space, infrastructure, and/or accessibility to fuel and transmission facilities. These sites are suitable for different capacity levels and technologies, including both renewable energy and non-renewable energy technologies for various sites.

Each of these Potential Sites offer a range of considerations relative to engineering and/or costs associated with the construction and operation of feasible technologies. In addition, each Potential Site has different characteristics that will require further definition and attention. Solely for the purpose of estimating water requirements for sites more suited for non-renewable energy technologies, it was assumed that either one dual-fuel (natural gas and light oil) simple cycle combustion turbine (CT), or a natural gas-fired CC unit, would be constructed at these Potential Sites unless otherwise noted.

A simple cycle CT would require approximately 50 gallons per minute (gpm) for both process and cooling water (assuming a cooling tower was utilized). A CC unit would require approximately up to 150 gpm for process water and up to 7.5 million gallons per day (mgd) per unit for cooling water (assuming a cooling tower is utilized). If an existing power plant site is ultimately selected for modernization (as is the case with FPL's CCEC, RBEC, and PEEC sites), the water requirements discussed above for a CC unit would be approximately correct for the modernized site. If a renewable energy generating technology is ultimately selected for one of these sites, the water requirements would be significantly less than those for CT or CC facilities.

Permits are presently considered to be obtainable for each of these sites. No significant environmental constraints are currently known for any of these sites. The Potential Sites briefly discussed below are presented in alphabetical order. At this time, FPL considers each site to be equally viable. As noted previously, FPL also considers a number of other sites as possible sites for future generation additions. These include all of the remainder of FPL's existing generation sites and other Greenfield sites.

⁷ As has been described in previous FPL Site Plans, FPL also considers a number of other sites as possible sites for future generation additions. These include the remainder of FPL's existing generation sites and other Greenfield sites. Greenfield sites that FPL currently does not own, or for which FPL has not currently secured the necessary rights to, are not specifically identified as Potential Sites in order to protect the economic interests of FPL and its customers.

Potential Site # 1: Babcock Ranch , Charlotte County

This site is located within the proposed Babcock Ranch Community on the north side of Tuckers Grade, approximately 10.5 miles north of the intersection of SR-80 and SR-31 and 1.1 miles east of SR-31. The project is bordered on the north by the Babcock Ranch Preserve owned by the State of Florida. This site is a possibility for an FPL photovoltaic (PV) facility. FPL has received all permits necessary to construct a 75 MW PV facility at this location.

a. U.S. Geological Survey (USGS) Map

A map of this site is found at the end of this chapter.

b. Land Uses

Existing land use on the site is the Babcock Ranch Overlay District, and it is zoned as the Babcock Ranch Overlay Zoning District. This land use and zoning allows for solar facilities.

c. Environmental Features

FPL anticipates mitigating for unavoidable wildlife and/or wetland impacts as needed as a result of a PV project constructed at this site.

d. Water Quantities

Minimal amounts of water, if any, would be required for a PV facility.

e. Supply Sources

Minimal water would be required for a PV facility. A small amount may be needed to occasionally clean the solar panels in the absence of sufficient rainfall. Any such water may be brought to the site by truck.

Potential Site # 2: DeSoto Solar Expansion, DeSoto County

The DeSoto site is located at 4051 Northeast Karson Street which is approximately 0.3 miles east of US 17 and immediately north of Bobay Road in Arcadia, Florida. The site is located in Sections 26, 27, & 35, Township 36 South, and Range 25 East. FPL owns an approximate 13,000 acre parcel in DeSoto County. FPL has designated approximately 5,177 acres for development of a photovoltaic (PV) facility.

The DeSoto site is home to a 25 MW PV facility that has been operational since 2009. Up to an additional 275 MW of PV generation could be constructed in phases on the remaining undeveloped land. FPL has initiated permitting for the additional PV facilities.

a. **U.S. Geological Survey (USGS) Map**

A map of this site is found at the end of this chapter.

b. **Land Uses**

Existing land use on the site is agricultural. The future land use is Electric Generating Facility.

c. **Environmental Features**

There are no significant environmental features on the site.

d. **Water Quantities**

Minimal amounts of water would be required for a future expansion of the existing PV facility.

e. **Supply Sources**

Minimal water would be required for an expanded PV facility. A small amount may be needed to occasionally clean the PV panels in the absence of sufficient rainfall. Potable water will be required in the administration building and maintenance building. FPL would propose to utilize existing wells onsite to accommodate water needs.

Potential Site # 3: Florida Heartland Solar, Glades County

This site is located within Glades County off SR 78. This site is a possibility for an FPL PV facility. FPL has initiated permitting for a PV facility of approximately 125 MW to be constructed at this location.

a. **U.S. Geological Survey (USGS) Map**

A map of this site is found at the end of this chapter.

b. **Land Uses**

The existing land use on the site is agriculture.

c. Environmental Features

FPL anticipates mitigating for unavoidable wildlife and/or wetland impacts as needed as a result of a PV project constructed at this site.

d. Water Quantities

Minimal amounts of water would be required for a PV facility.

e. Supply Sources

Minimal water would be required for a PV facility. A small amount may be needed to occasionally clean the PV panels in the absence of sufficient rainfall. Any such water may be brought to the site by truck.

Potential Site # 4: Hendry County

FPL has acquired a site in southeast Hendry County, off CR 833. This site is a possibility for a future PV facility and/or natural gas power generation. The site is approximately 3,127 acres.

a. U.S. Geological Survey (USGS) Map

A USGS map of the county has been included at the end of this chapter.

b. Land Uses

Hendry County has predominantly agricultural land use.

c. Environmental Features

FPL anticipates mitigating for unavoidable wildlife and/or wetland impacts as needed as a result of a power generation project constructed at this site.

d. Water Quantities

Minimal amounts of water would be required for a PV facility. Natural gas generation would require approximately up to 150 gallons per minute (gpm) for process water and up to 7.5 million gallons per day (mgd) per unit for cooling water (assuming a cooling tower is utilized).

e. Supply Sources

Minimal water would be required for a PV facility. A small amount may be needed to occasionally clean the solar panels in the absence of sufficient rainfall. Any such

water may be brought to the site by truck. The supply of water for fossil generation would be dependent upon the capacity of the generating unit(s) and the generation technology to be implemented.

Potential Site # 5: Manatee Plant Site, Manatee County

The existing FPL Manatee Plant 9,500-acre site is located in unincorporated north-central Manatee County. The existing power generating facilities are located in all or portions of Sections 18 and 19 of Township 33S, Range 20-E. The plant site lies approximately 5 miles east of Parrish, Florida. It is approximately 5 miles east of U.S. 301 and 9.5 miles east of Interstate Highway 75 (I-75). The existing plant is approximately 2.5 miles south of the Hillsborough-Manatee County line; a portion of the north property boundary of the plant site abuts the county line. State Road 62 (SR 62) is about 0.7 mile south of the plant, with the plant entrance road going north from that highway. This site is a possible location for an FPL PV facility. FPL has received the federal and state permits required to construct approximately 40 MW of PV at this location.

a. **U.S. Geological Survey (USGS) Map**

A map of the site is found at the end of this chapter.

b. **Land Uses**

Existing land use on the site is agricultural. The property is zoned Planned Development / Public Interest (PD-PI), which will allow for electrical generation.

c. **Environmental Features**

FPL anticipates mitigating for unavoidable wildlife and/or wetland impacts as needed as a result of a PV project constructed at this site.

d. **Water Quantities**

Minimal amounts of water would be required for a PV facility.

e. **Supply Sources**

Minimal water would be required for a PV facility. A small amount may be needed to occasionally clean the PV panels in the absence of sufficient rainfall. Any such water may be brought to the site by truck.

Potential Site # 6: Martin County

FPL is currently evaluating potential sites in Martin County for a future PV facility. No specific locations have been selected at this time.

a. **U.S. Geological Survey (USGS) Map**

A USGS map of the county has been included at the end of this chapter.

b. **Land Uses**

This information is not available because a specific site has not been selected at this time.

c. **Environmental Features**

This information is not available because a specific site has not been selected at this time.

d. **Water Quantities**

Minimal amounts of water would be required for a PV facility.

e. **Supply Sources**

Minimal water would be required for a PV facility. A small amount may be needed to occasionally clean the PV panels in the absence of sufficient rainfall.

Potential Site # 7: Northeast Okeechobee County

FPL has purchased a 2,832 acre site in Northeast Okeechobee County for a future PV facility or natural gas generation.

a. **U.S. Geological Survey (USGS) Map**

A USGS map of the site has been included at the end of this chapter.

b. **Land Uses**

The site has predominantly agricultural land use.

c. **Environmental Features**

FPL anticipates mitigating for unavoidable wildlife and/or wetland impacts as needed as a result of a PV project constructed at this site.

d. Water Quantities

Water requirements for fossil generation would be up to 150 gallons per minute (gpm) for process water and up to 7.5 million gallons per day (mgd) per unit for cooling water (assuming a cooling tower would be utilized). Needed water quantities would be significantly less for a PV facility.

e. Supply Sources

Existing groundwater and/or regional water supply initiatives are potential water sources.

Potential Site # 8: Palatka Site, Putnam County

FPL is currently evaluating a site adjacent to the former FPL Putnam Plant site in Putnam County for future fossil-fueled generation. The approximately 170 acre site was the location of the former FPL Palatka Plant which was dismantled in the 1990s.

a. U.S. Geological Survey (USGS) Map

A map of the site is found at the end of this chapter.

b. Land Uses

The site has a land use designation of Industrial.

c. Environmental Features

The majority of site has been previously impacted by past power plant operations. No significant environmental features have been identified at this time.

d. Water Quantities

Water requirements would be up to 150 gallons per minute (gpm) for process water and up to 7.5 million gallons per day (mgd) per unit for cooling water (assuming a cooling tower).

e. Supply Sources

The St John's River, existing groundwater, and/or regional water supply initiatives are potential water sources.

Potential Site # 9: Putnam County

FPL is currently evaluating additional potential sites in Putnam County for a future PV facility or natural gas power generation. Sites currently under investigation are approximately 2,800 acres. No specific locations have been selected at this time.

a. U.S. Geological Survey (USGS) Map

A USGS map of the county has been included at the end of this chapter.

b. Land Uses

This information is not available because a specific site has not been selected at this time.

c. Environmental Features

This information is not available because a specific site has not been selected at this time.

d. Water Quantities

Minimal amounts of water would be required for a PV facility. Natural gas power generation would require approximately up to 150 gallons per minute (gpm) for process water and up to 7.5 million gallons per day (mgd) per unit for cooling water (assuming a cooling tower is utilized).

e. Supply Sources

Existing groundwater is a potential water source.

Potential Site # 10: Space Coast Solar Expansion, Brevard County

The Space Coast site is located at NASA's Kennedy Space Center property in Brevard County. This site currently houses a 10 MW PV facility which began operating in 2010, with the potential to expand the PV generating capacity by an additional 10 MW. FPL is also evaluating the potential for further expansion beyond the existing site, within the Space Center property.

a. U.S. Geological Survey (USGS) Map

A USGS map of the site has been included at the end of this chapter.

b. Land Uses

NASA, a federal agency, has approved use of the land at the site for PV generation.

c. Environmental Features

There are no significant environmental features on this site.

d. Water Quantities

Minimal amounts of water would be required for an expansion of the PV facility.

e. Supply Sources

Minimal water would be required for a PV facility. A small amount may be needed to occasionally clean the PV panels in the absence of sufficient rainfall.

Any such water would be brought to the site by truck or would come from existing onsite wells.

CHAPTER V

Other Planning Assumptions & Information

(This page is left intentionally blank.)

Introduction

The Florida Public Service Commission (FPSC), in Docket No. 960111-EU, specified certain information that was to be included in an electric utility's Ten Year Power Plant Site Plan filing. Among this specified information was a group of 12 items listed under a heading entitled "Other Planning Assumptions and Information." These 12 items basically concern specific aspects of a utility's resource planning work. The FPSC requested a discussion or a description of each of these items.

These 12 items are addressed individually below as separate "Discussion Items".

Discussion Item # 1: Describe how any transmission constraints were modeled and explain the impacts on the plan. Discuss any plans for alleviating any transmission constraints.

FPL's resource planning work considers two types of transmission limitations/constraints: external limitations and internal limitations. External limitations deal with FPL's ties to its neighboring systems. Internal limitations deal with the flow of electricity within the FPL system.

The external limitations are important since they affect the development of assumptions for the amount of external assistance that is available to the FPL system as well as the amount and price of economy energy purchases. Therefore, these external limitations are incorporated both in the reliability analysis and economic analysis aspects of resource planning. The amount of external assistance which is assumed to be available is based on the projected transfer capability to FPL from outside its system as well as historical levels of available assistance. In the loss of load probability (LOLP) portion of its reliability analyses, FPL models this amount of external assistance as an additional generator within FPL's system which provides capacity in all but the peak load months. The assumed amount and price of economy energy are based on historical values and projections from production costing models.

Internal transmission limitations are addressed by identifying potential geographic locations for potential new generating units that minimize adverse impacts to the flow of electricity within FPL's system. The internal transmission limitations are also addressed by developing the direct costs for siting new units at different locations, by evaluating the cost impacts created by the new unit/unit location combination on the operation of existing units in the FPL system, and/or by evaluating the costs of transmission additions that may be needed to address regional concerns regarding an imbalance between load and generation in a given region. Both of these site- and

system-related transmission costs are developed for each different unit/unit location option or groups of options. In addition, transfer limits for capacity and energy that can be imported into the Southeastern (Miami-Dade and Broward Counties) region of FPL's system are also developed for use in FPL's production costing analyses. (A further discussion of the Southeastern Florida region, and the need to maintain a regional balance between generation and transmission contributions to meet regional load, is found in Chapter III.)

FPL's annual transmission planning work determines transmission additions needed to address limitations and to maintain/enhance system reliability. FPL's planned transmission facilities to interconnect and integrate FPL's resource plans and those that must be certified under the Transmission Line Siting Act are presented in Chapter III.

Discussion Item # 2: Discuss the extent to which the overall economics of the plan were analyzed. Discuss how the plan is determined to be cost-effective. Discuss any changes in the generation expansion plan as a result of sensitivity tests to the base case load forecast.

FPL typically performs economic analyses of competing resource plans using as an economic criterion FPL's levelized system average electric rates (i.e., a Rate Impact Measure or RIM approach). In addition, for analyses in which DSM levels are not changed, FPL uses the equivalent criterion of the cumulative present value of revenue requirements for the FPL system.⁸

The load forecast that is presented in FPL's 2012 Site Plan was developed in September 2011. The only load forecast sensitivities analyzed during 2011/early 2012 were high load forecast sensitivities developed solely to analyze the quality of FPL's future reserves and the projected frequency at which load control might be implemented. These analyses are on-going and the load forecast sensitivities have not been used to determine potential changes to the resource plan that is presented in this Site Plan document.

⁸ FPL's basic approach in its resource planning work is to base decisions on a lowest electric rate basis. However, when DSM levels are considered a "given" in the analysis (i.e., when only new generating options are considered), the lowest electric rate basis approach and the lowest system cumulative present value of revenue requirements basis approach, yield identical results in terms of which resource options are more economic. In such cases FPL evaluates resource options on the simpler – to – calculate (but equivalent) lowest system revenue requirements basis.

Discussion Item # 3: Explain and discuss the assumptions used to derive the base case fuel forecast. Explain the extent to which the utility tested the sensitivity of the base case plan to high and low fuel price scenarios. If high and low fuel price sensitivities were performed, explain the changes made to the base case fuel price forecast to generate the sensitivities. If high and low fuel price scenarios were performed as part of the planning process, discuss the resulting changes, if any, in the generation expansion plan under the high and low fuel price scenario. If high and low fuel price sensitivities were not evaluated, describe how the base case plan is tested for sensitivity to varying fuel prices.

The basic assumptions FPL used in deriving its fuel price forecasts are discussed in Chapter III of this document. FPL used three fuel cost, and three environmental compliance cost, forecasts in analyses supporting its 2011 nuclear cost recovery filing. FPL also utilized one fuel cost forecast, and one environmental compliance cost forecast, in analyses supporting its 2011 Port Everglades modernization (PEEC) determination of need filing. In response to discovery requests in the PEEC need docket, sensitivity forecasts assuming low fuel costs, high fuel costs, and low environmental compliance costs were also analyzed for PEEC.

The high and low fuel cost forecasts are derived from a calculation of the historical volatility of the 12-month forward price for one year ahead. From this range of volatility, a reasonable value from the high end of the range is applied to the medium cost fuel cost forecast to develop a high cost fuel cost forecast. Similarly, a reasonable value from the low end of the range is applied to the medium cost fuel cost forecast to develop a low cost fuel cost forecast.

The resource plan presented in this Site Plan is based, in part, on those prior analyses. For that reason, this resource plan has not been further tested for different fuel cost forecasts.

Discussion Item # 4: Describe how the sensitivity of the plan was tested with respect to holding the differential between oil/gas and coal constant over the planning horizon.

As described above in the answer to Discussion Item # 3, FPL used up to three fuel cost forecasts in its 2011/early 2012 resource planning analyses. While these forecasts did not represent a constant cost differential between oil/gas and coal, a variety of fuel cost differentials were represented in these forecasts.

Discussion Item # 5: Describe how generating unit performance was modeled in the planning process.

The performance of existing generating units on FPL's system was modeled using current projections for scheduled outages, unplanned outages, capacity output ratings, and heat rate information. Schedule 1 in Chapter I and Schedule 8 in Chapter III present the current and projected capacity output ratings of FPL's existing units. The values used for outages and heat rates are generally consistent with the values FPL has used in planning studies in recent years.

In regard to new unit performance, FPL utilized current projections for the capital costs, fixed and variable operating & maintenance costs, capital replacement costs, construction schedules, heat rates, and capacity ratings for all construction options in its resource planning work. A summary of this information for the new capacity options FPL currently projects to add over the reporting horizon for this document is presented on the Schedule 9 forms in Chapter III.

Discussion Item # 6: Describe and discuss the financial assumptions used in the planning process. Discuss how the sensitivity of the plan was tested with respect to varying financial assumptions.

In its 2011 resource planning work, FPL's financial assumptions were: i) a capital structure of 40.88% debt and 59.12% equity; (ii) a 5.50% cost of debt; (iii) a 10.0% return on equity; and (iv) an after-tax discount rate of 7.29%. No sensitivities of these financial assumptions were used in FPL's 2011/early 2012 resource planning work.

Discussion Item # 7: Describe in detail the electric utility's Integrated Resource Planning process. Discuss whether the optimization was based on revenue requirements, rates, or total resource cost.

FPL's integrated resource planning (IRP) process is described in detail in Chapter III of this document.

The standard basis for comparing the economics of competing resource plans in FPL's basic IRP process is the impact of the plans on FPL's electricity rate levels with the objective generally being to minimize FPL's projected levelized system average electric rate (i.e., a Rate Impact Measure or RIM approach). As discussed in response to Discussion Item # 2, both the electricity

rate perspective and the cumulative present value of system revenue requirement perspective are identical when DSM levels are unchanged between competing resource plans. Therefore, in planning work in which DSM levels were unchanged, the equivalent, but simpler to calculate, cumulative present value of revenue requirements perspective was utilized.

Discussion Item # 8: Define and discuss the electric utility's generation and transmission reliability criteria.

FPL currently uses two system reliability criteria in its resource planning work that addresses generation, purchase, and DSM options. One of these is a minimum 20% Summer and Winter reserve margin. The other reliability criterion is a maximum of 0.1 days per year loss-of-load-probability (LOLP). These reliability criteria are discussed in Chapter III of this document. As discussed briefly in the Executive Summary, and in more detail in Chapter III, FPL will be examining the extent to which its system reserves are projected to be dependent upon DSM resources and generation resources in its 2012 resource planning work. The results of this examination could result in a change to FPL's reliability criteria.

In regard to transmission reliability analysis work, FPL has adopted transmission planning criteria that are consistent with the planning criteria established by the Florida Reliability Coordinating Council (FRCC). The FRCC has adopted transmission planning criteria that are consistent with the Reliability Standards established by the North American Electric Reliability Council (NERC). The *NERC Reliability Standards* are available on the internet site (<http://www.nerc.com/>).

In addition, FPL has developed a *Facility Connection Requirements* (FCR) document as well as a *Facility Rating Methodology* document that are also available on the internet under the FPL OATT Documents directory at <https://www.oatioasis.com/FPL/index.html>.

Generally, FPL limits its transmission facilities to 100% of the applicable thermal rating. The normal and contingency voltage criteria for FPL stations are provided below:

Normal/Contingency

<u>Voltage Level (kV)</u>	<u>Vmin (p.u.)</u>	<u>Vmax (p.u.)</u>
69, 115, 138	0.95/0.95	1.05/1.07
230	0.95/0.95	1.06/1.07
500	0.95/0.95	1.07/1.09
Turkey Point (*)	1.01/1.01	1.06/1.06
St. Lucie (*)	1.00/1.00	1.06/1.06

(*) Voltage range criteria for FPL's Nuclear Power Plants

There may be isolated cases for which FPL may have determined that it is acceptable to deviate from the general criteria stated above. There are several factors that could influence these criteria, such as the overall number of potential customers that may be impacted, the probability of an outage actually occurring, or transmission system performance, as well as others.

Discussion Item # 9: Discuss how the electric utility verifies the durability of energy savings for its DSM programs.

The projected impacts of FPL's DSM programs on demand and energy consumption are revised periodically. Engineering models, calibrated with current field-metered data, are updated at regular intervals. Participation trends are tracked for all of the FPL DSM programs in order to adjust impacts each year for changes in the mix of efficiency measures being installed by program participants. For its load management programs, FPL conducts periodic tests of the load control equipment to ensure that the equipment is functioning correctly. These tests, plus actual, non-test load management events, also allow FPL to gauge the MW reduction capabilities of its load management programs on an on-going basis.

Survey data is collected from non-participants in order to establish the baseline efficiency. Participant data is compared against non-participant data to establish the demand and energy saving benefits of the utility DSM program versus what would be installed in the absence of the program.

Discussion Item # 10: Discuss how strategic concerns are incorporated in the planning process.

The Executive Summary and Chapter III provide a discussion of a variety of system concerns/issues that influence FPL's resource planning process. Please see those chapters for a discussion of those concerns/issues.

In addition to these system concerns/issues, there are other strategic factors FPL typically considers when choosing between resource options. These include the following: (1) technology risk; (2) environmental risk, and (3) site feasibility. The consideration of these factors may include both economic and non-economic aspects.

Technology risk is an assessment of the relative maturity of competing technologies. For example, a prototype technology, which has not achieved general commercial acceptance, has a higher risk than a technology in wide use and, therefore, assuming all else equal, is less desirable.

Environmental risk is an assessment of the relative environmental acceptability of different generating technologies and their associated environmental impacts on the FPL system, including environmental compliance costs. Technologies regarded as more acceptable from an environmental perspective for FPL's resource plan are those which minimize environmental impacts for the FPL system as a whole through highly efficient fuel use, state of the art environmental controls, etc.

Site feasibility assesses a wide range of economic, regulatory, and environmental factors related to successfully developing and operating the specified technology at the site in question. Projects that are more acceptable have sites with few barriers to successful development.

All of these factors play a part in FPL's planning and decisions, including its decisions to construct capacity or to purchase power.

Discussion Item # 11: Describe the procurement process the electric utility intends to utilize to acquire the additional supply-side resources identified in the electric utility's ten-year site plan.

As shown in this 2012 Site Plan, beyond the capacity additions for which a need determination has already been approved (nuclear uprates and the modernizations at Cape Canaveral, Riviera, and Port Everglades), FPL currently projects no new capacity additions for the years 2017 through 2021 except for a one-year power purchase of approximately 250 MW for the year 2021. FPL anticipates that this short-term purchase would be acquired after discussions and negotiations with potential capacity suppliers at some point in the future.

In regard to the capacity additions that are underway for which a need determination has already been approved, the nuclear uprates (and the new nuclear units not addressed in the reporting period of this document), do not lend themselves to an RFP approach involving bids from third parties who would build new nuclear generation capacity. In addition, nuclear capacity additions are exempted from the Commission's Bid Rule by section 403.519 (4) (c). For these nuclear projects, FPL's procurement activities are conducted to ensure the best combination of quality and cost for the delivered products. Furthermore, the modernization projects at Cape Canaveral, Riviera, and Port Everglades received Commission waivers from the Bid Rule due to attributes specific to modernization projects (such as use of existing land, water, transmission, etc.) plus other economic benefits to FPL's customers. These waivers from the Bid Rule were granted in Order No. PSC-08-0591-FOF-EI for Cape Canaveral and Riviera and in Order No. PSC-11-0360-PAA-EI for Port Everglades.

If circumstances change and another large-scale capacity addition decision needs to be made during the reporting period of this document, FPL expects that its decision-making will be conducted in a manner consistent with the Commission's Bid Rule.

Identification of self-build options, beyond those units already approved by the FPSC and Governor and Siting Board or units for which FPL may be then seeking approval, in future FPL Site Plans will not be an indication that FPL has pre-judged any capacity solicitation it may conduct. The identification of future generating units is required of FPL in its Site Plan filings and represents those alternatives that appear to be FPL's best, most cost-effective self-build options at the time. FPL reserves the right to refine its planning analyses and to identify other self-build options. Such refined analyses have the potential to yield a variety of self-build options, some of

which might not require an RFP. If an RFP is issued for Supply options, FPL reserves the right to choose the best alternative for its customers, even if that option is not an FPL self-build option.

Discussion Item # 12: Provide the transmission construction and upgrade plans for electric utility system lines that must be certified under the Transmission Line Siting Act (403.52 – 403.536, F. S.) during the planning horizon. Also, provide the rationale for any new or upgraded line.

- (1) FPL has identified the need for a new 230 kV transmission line that required certification under the Transmission Line Siting Act which was issued in April 2006. The new line is to be completed in two phases connecting FPL's St. Johns Substation to FPL's Pringle Substation (also shown on Table III.E.1 in Chapter III). Phase 1 was completed in May 2009 and consisted of a new line connecting Pringle to a new Pellicer Substation. Phase 2 is planned to connect St. Johns to Pellicer and is scheduled to be completed by December 2016. The construction of this line is necessary to serve existing and future customers in the Flagler and St. Johns areas in a reliable and effective manner.

- (2) FPL has identified the need for a new 230 kV transmission line (by December 2014) that required certification under the Transmission Line Siting Act which was issued on November 2008. The new line will connect FPL's Manatee Substation to FPL's proposed Bob White Substation (also shown on Table III.E.1 in Chapter III). The construction of this line, scheduled to be completed in 2014, is necessary to serve existing and future customers in the Manatee and Sarasota areas in a reliable and effective manner.

(This page is intentionally left blank.)