



**CLIPPERCREEK, INC.**

INNOVATIVE INFRASTRUCTURE FOR  
ELECTRIC AND HYBRID VEHICLES

**ProMountDuo™ (PMD-10)**  
**PEDESTAL INSTALLATION GUIDE**



**This page was intentionally left blank.**



# WARNING:

Do not overtighten the #10  
self-tapping screws!

**This kit is manufactured with extruded holes. Use limited torque power tools and finish tightening by hand.**



## PLEASE NOTE

This user's manual includes the latest information at the time of printing.

ClipperCreek, Inc. reserves the right to make changes to this product without further notice. Changes or modifications to this product by other than an authorized service facility may void the product warranty.

TESLA® and T E S L A ® are registered trademarks of TESLA® Motors, Inc. and are used under license. TESLA® Motors, Inc. is not responsible for the content or accuracy of any statements or instructions made in this document and disclaims any responsibility for such statements or instructions.

If you have questions about the use of this product, contact your customer service representative. Refer to the Customer Support section located in this guide.

**Please visit ClipperCreek's website @ [www.clippercreek.com](http://www.clippercreek.com)**

ProMountDuo™ Installation Guide Version 5, June 2016

ProMountDuo™ Installation Guide V5.pdf

Copyright © 2016 ClipperCreek, Inc.

All rights reserved. Printed in the USA.



# TABLE OF CONTENTS

IMPORTANT SAFETY INSTRUCTIONS ..... 6

TOOLS REQUIRED ..... 7

INSTALLATION REQUIREMENTS AND CONFIGURATIONS ..... 7-15

PACKING LIST..... 16-17

OPTIONAL ORDERABLE ITEMS..... 18

INSTALLATION

    INITIAL PEDESTAL INSTALLATION ..... 19-25

    HCS EVSE INSTALLATION..... 26-28

    LCS/ACS EVSE INSTALLATION ..... 29-30

    TESLA® EVSE INSTALLATION ..... 31-35

    FINAL PEDESTAL INSTALLATION ..... 36

CUSTOMER SUPPORT..... 37

WARRANTY INFORMATION..... 38



## IMPORTANT SAFETY INSTRUCTIONS

Before You Begin: Read these instructions completely, including these Important Safety Instructions.

**Note to the Installer:** Follow Instructions carefully as this unit has self-tapping screws and is not meant to be disassembled. Some illustrations have been changed to grayscale to show detail for easier assembly. Be sure to leave these instructions with the user.

**Note to the User:** Keep these instructions for further reference.

The TESLA® Wall Connector and ClipperCreek EVSE (Electric Vehicle Supply Equipment) are designed with the safety concerns of the end user as an utmost priority; however, the following safety precautions must be read and followed:

- The EVSE and electrical wiring should be installed by a qualified electrician in accordance with local electrical codes and ordinances.
- Grounding Instructions - The EVSE should be connected to a grounded, metal, permanent wiring system; or an equipment-grounding conductor should be run with circuit conductors and connected to a grounding terminal or lead on the EVSE. Connections to the EVSE should comply with all local electrical codes and ordinances.
- Call your local service provider anytime a procedural question arises; DO NOT attempt to perform a procedure you are unsure of.
- Read all installation instructions carefully before performing the pedestal and EVSE installation.



## TOOLS REQUIRED FOR ASSEMBLING THE ProMountDuo™ PEDESTAL WITH CLIPPERCREEK HCS, LCS/ACS, OR TESLA® EVSE

The following tools are required for the installation and assembly of the ClipperCreek ProMountDuo™ pedestal components.

- Ratcheting Low-Profile Driver with T25 and T30 Torx bits (there are some tight spaces). IF USING HIGH POWER TOOLS ON THE TORX SCREWS, USE WITH CARE, ON A LOW TORQUE SETTING, AS THEY MAY STRIP AND/OR DENT THE SURFACES OF THE PEDESTAL.
- 3/16" Hex Wrench (Allen key)
- Socket Wrench (appropriately sized for the customer-supplied Anchor Nuts)
- Installers Preferred tools for flexible conduit trimming
- Installers Preferred tools for knockout removal
- Level
- Tape Measure
- Base Cardboard Template (included in the ProMountDuo™ packaging; this template can be found and punched out from the Cap and Base cardboard packaging)
- **REQUIRED IF INSTALLING LCS/ACS AND TESLA® EVSE:** Silicone for sealing Conduit.
- TESLA® EVSE only: T10 Torx Driver and T20 Security pin Torx Driver
- OPTIONAL: ClipperCreek CP-15 EVSE Tester (ClipperCreek part number 0500-01-000, applicable to ClipperCreek EVSE only)

## ProMountDuo™ PEDESTAL INSTALLATION GUIDE: CLIPPERCREEK HCS, LCS/ACS AND TESLA® EVSE CONFIGURATIONS

- CONFIGURATION A:** Single ClipperCreek HCS EVSE (dimensions shown in **Figure 1**)
- CONFIGURATION B:** Dual ClipperCreek HCS EVSE (dimensions shown in **Figure 1**)
- CONFIGURATION C:** Single ClipperCreek LCS/ACS EVSE (dimensions shown in **Figure 2**)
- CONFIGURATION D:** Dual ClipperCreek LCS/ACS EVSE (dimensions shown in **Figure 2**)
- CONFIGURATION E:** Combo ClipperCreek HCS and LCS/ACS EVSE  
(extrapolate dimensions using **Figure 1** and **Figure 2**)
- CONFIGURATION F:** Single TESLA® EVSE (dimensions shown in **Figure 3**)
- CONFIGURATION G:** Dual TESLA® EVSE (dimensions shown in **Figure 3**)
- CONFIGURATION H:** Combo ClipperCreek HCS and TESLA® EVSE  
(extrapolate dimensions using **Figure 1** and **Figure 3**)
- CONFIGURATION I:** Combo ClipperCreek LCS/ACS and TESLA® EVSE  
(extrapolate dimensions using **Figure 2** and **Figure 3**)



### HCS EVSE SINGLE AND DUAL MOUNT CONFIGURATION DIMENSIONS

Figure 1

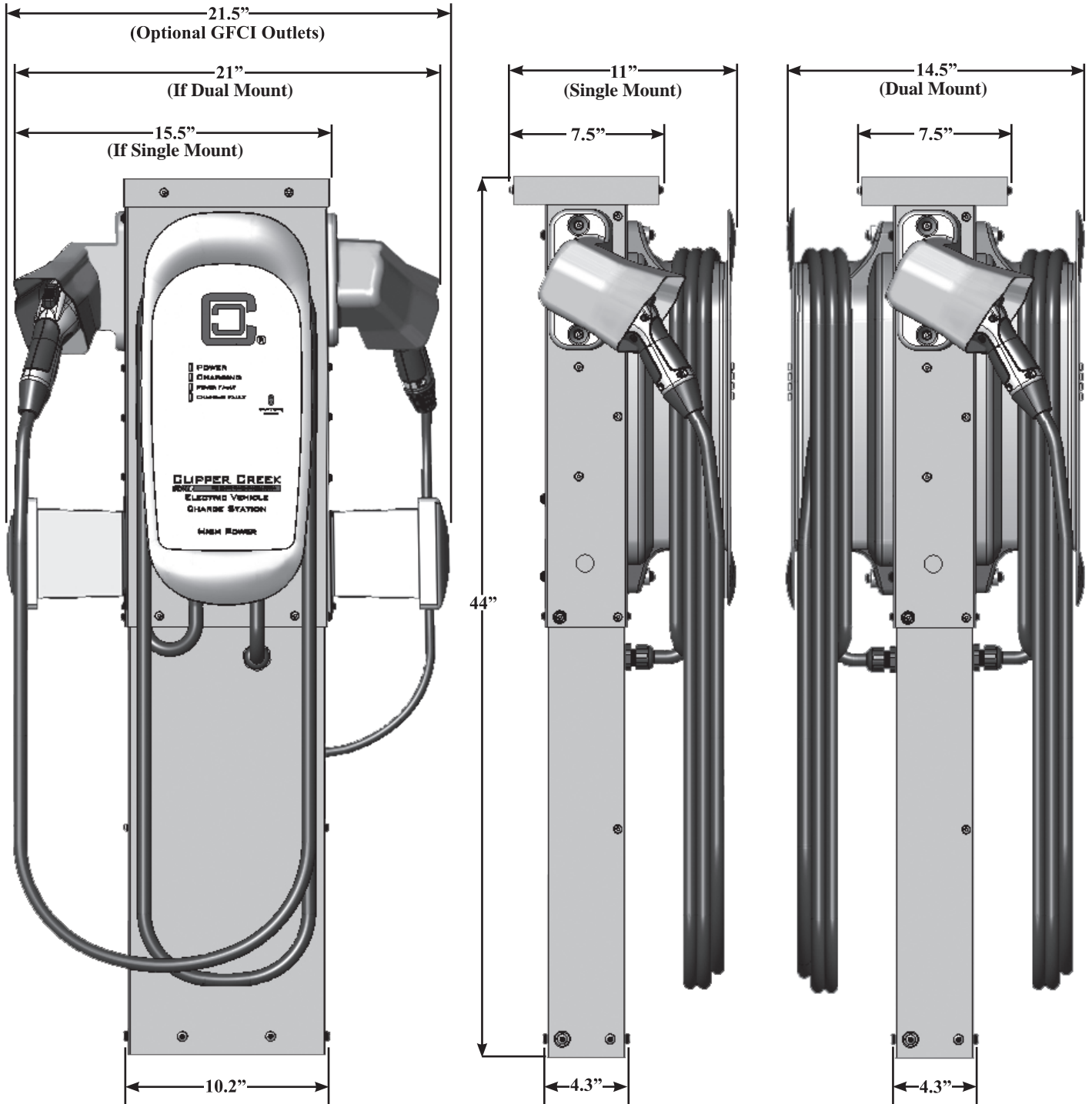





LCS/ACS EVSE SINGLE AND DUAL MOUNT CONFIGURATION DIMENSIONS

Figure 2

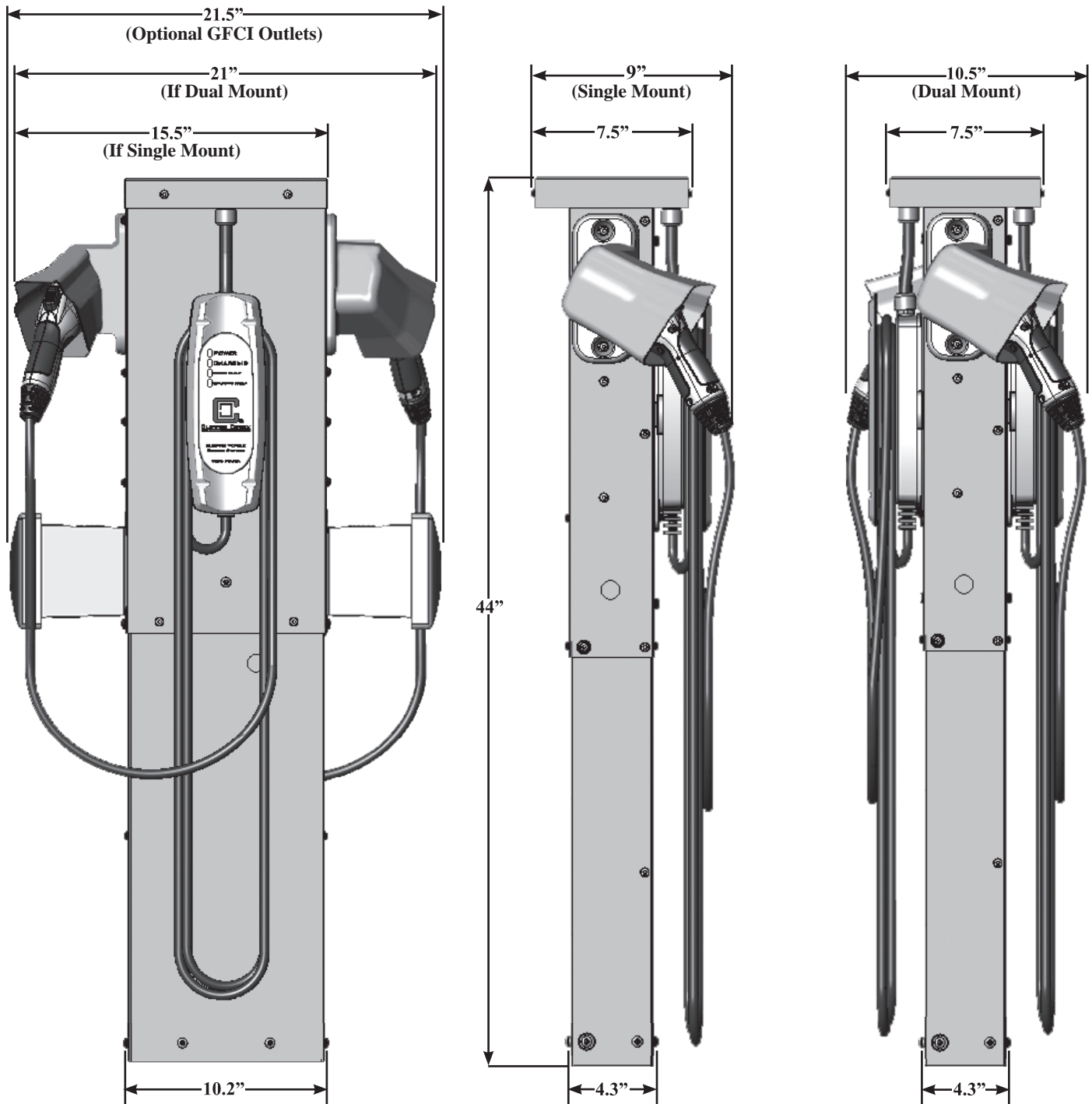



### TESLA® EVSE SINGLE AND DUAL MOUNT CONFIGURATION DIMENSIONS

Figure 3

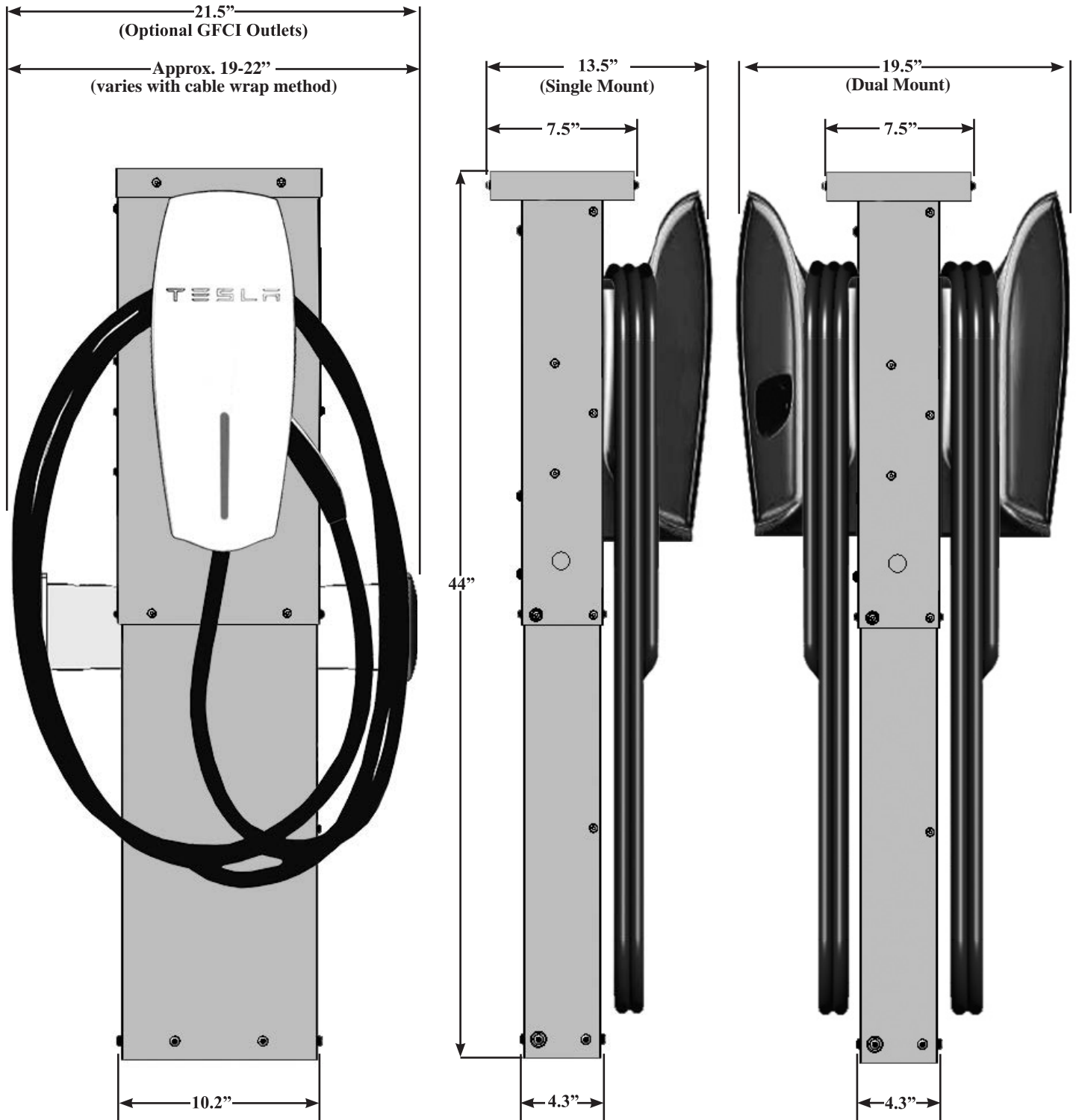



## INSTALLATION REQUIREMENTS AND CONFIGURATIONS

Refer to the EVSE documentation to determine the appropriate circuit breaker current capacity. All conductors must be appropriately sized for the EVSE current capacity, in accordance with local and national electrical codes.

### CONFIGURATION A:

#### Required Equipment for a Single-Mount Pedestal with one ClipperCreek HCS EVSE (One EVSE per Pedestal):

- One (1) ClipperCreek ProMountDuo™ Kit, ClipperCreek part number 0300-00-025.
- One (1) ClipperCreek HCS EVSE, part number is determined by amperage and options selected.
- One (1) dedicated 208 or 240 VAC branch circuit.
- One (1) circuit breaker appropriately sized for the EVSE charging capacity.
- Two (2) Live Line conductors with enough length to comfortably pull all the way through and above the top of the pedestal (5 feet is adequate).
- One (1) Ground Line conductor with enough length to comfortably pull all the way through and above the top of the pedestal (5 feet is adequate).
- Conduit sized to fit all Live Line and Ground Line conductors.
- Four (4) Anchor Bolts with Nuts and Washers (additional washers may be required for leveling)

### CONFIGURATION A



Single ClipperCreek HCS EVSE

### CONFIGURATION B:

#### Required Equipment for a Dual-Mount Pedestal with two ClipperCreek HCS EVSE (Two EVSE per Pedestal):

- One (1) ClipperCreek ProMountDuo™ Kit, ClipperCreek part number 0300-00-025.
- Two (2) ClipperCreek HCS EVSE, part numbers are determined by amperage and options selected.
- Two (2) dedicated 208 or 240 VAC branch circuits.
- Two (2) circuit breakers, appropriately sized with respect to the charging capacity of each EVSE.
- Two pairs (2x2) Live Line conductors (one pair for each EVSE) with enough length to comfortably pull all the way through and above the top of the pedestal (5 feet is adequate).
- Two (2) Ground Line conductors (one for each EVSE) or a single bonded Ground Line with enough length to comfortably pull all the way through and above the top of the pedestal (5 feet is adequate).
- Conduit sized to fit all Live Line and Ground Line conductors.
- Four (4) Anchor Bolts with Nuts and Washers (additional washers may be required for leveling)

### CONFIGURATION B



Dual ClipperCreek HCS EVSE



# INSTALLATION REQUIREMENTS AND CONFIGURATIONS

(continued)

## CONFIGURATION C:

**Required Equipment for a Combo Dual-Mount Pedestal with one HCS EVSE and one LCS/ACS EVSE (Two EVSE per Pedestal):**

- One (1) ClipperCreek ProMountDuo™ Kit, ClipperCreek part number 0300-00-025.
- One (1) ClipperCreek HCS EVSE, part number is determined by amperage and options selected.
- One (1) ClipperCreek LCS/ACS EVSE, part number is determined by amperage and options selected.
- Two (2) dedicated branch circuits, voltages dependent upon the EVSE options selected.
- Two (2) circuit breakers, appropriately sized with respect to the charging capacity of each EVSE.
- Appropriately sized service wiring based on EVSE power requirements (reference EVSE Product manual). Each conductor must have enough length to comfortably pull all the way through and above the top of the pedestal (5 feet is adequate).
- Two (2) Ground Line conductors (one for each EVSE) or a single bonded Ground Line with enough length to comfortably pull all the way through and above the top of the pedestal (5 feet is adequate).
- Conduit sized to fit all Live Line and Ground Line conductors.
- Four (4) Anchor Bolts with Nuts and Washers (additional washers may be required for leveling)

**CONFIGURATION C**



**Combo ClipperCreek HCS and LCS/ACS EVSE**



## INSTALLATION REQUIREMENTS AND CONFIGURATIONS

(continued)

### CONFIGURATION D:

**Required Equipment for a Single-Mount Pedestal with one ClipperCreek LCS/ACS EVSE (One EVSE per Pedestal):**

- One (1) ClipperCreek ProMountDuo™ Kit, ClipperCreek part number 0300-00-025.
- One (1) ClipperCreek LCS/ACS EVSE, part number is determined by amperage and options selected.
- One (1) dedicated branch circuit, voltage dependent upon the EVSE option selected.
- One (1) circuit breaker appropriately sized for the EVSE charging capacity.
- Appropriately sized service wiring based on EVSE power requirements (reference EVSE Product manual). Each conductor must have enough length to comfortably pull all the way through and above the top of the pedestal (5 feet is adequate).
- One (1) Ground Line conductor with enough length to comfortably pull all the way through and above the top of the pedestal (5 feet is adequate).
- Conduit sized to fit all Live Line and Ground Line conductors.
- Four (4) Anchor Bolts with Nuts and Washers (additional washers may be required for leveling).

CONFIGURATION D

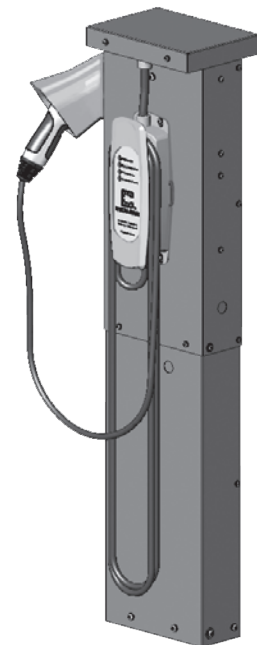

Single ClipperCreek  
LCS/ACS EVSE

### CONFIGURATION E:

**Required Equipment for a Dual-Mount Pedestal with two ClipperCreek LCS/ACS EVSE (Two EVSE per Pedestal):**

- One (1) ClipperCreek ProMountDuo™ Kit, ClipperCreek part number 0300-00-025.
- Two (2) ClipperCreek LCS/ACS EVSE, part number is determined by amperage and options selected.
- Two (2) dedicated branch circuits, voltages dependent upon the EVSE option selected.
- Two (2) circuit breakers, appropriately sized with respect to the charging capacity of each EVSE.
- Appropriately sized service wiring based on EVSE power requirements (reference EVSE Product manual). Each conductor must have enough length to comfortably pull all the way through and above the top of the pedestal (5 feet is adequate).
- Two (2) Ground Line conductors (one for each EVSE) or a single bonded Ground Line with enough length to comfortably pull all the way through and above the top of the pedestal (5 feet is adequate).
- Conduit sized to fit all Live Line and Ground Line conductors.
- Four (4) Anchor Bolts with Nuts and Washers (additional washers may be required for leveling).

CONFIGURATION E

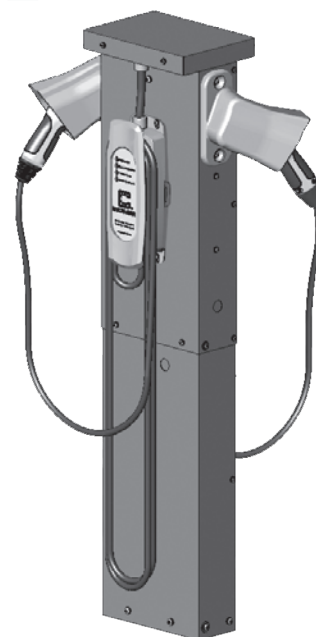

Dual ClipperCreek  
LCS/ACS EVSE



## INSTALLATION REQUIREMENTS AND CONFIGURATIONS (continued)

### CONFIGURATION F:

**Required Equipment for a Single-Mount Pedestal with one TESLA® EVSE (One EVSE per Pedestal):**

- One (1) ClipperCreek ProMountDuo™ Kit, ClipperCreek part number 0300-00-025.
- One (1) TESLA® EVSE, TESLA® part number 1050067-01-E.
- One (1) dedicated 208 or 240 VAC branch circuit.\*
- One (1) circuit breaker appropriately sized for the EVSE charging capacity.\*
- Appropriately sized service wiring based on EVSE power requirements (reference EVSE Product manual). Each conductor must have enough length to comfortably pull all the way through and above the top of the pedestal (5 feet is adequate).
- One (1) Ground Line conductor with enough length to comfortably pull all the way through and above the top of the pedestal (5 feet is adequate).
- Conduit sized to fit all conductors.
- Four (4) Anchor Bolts with Nuts and Washers (additional washers may be required for leveling)

CONFIGURATION F



Single TESLA® EVSE

### CONFIGURATION G:

**Required Equipment for a Dual-Mount Pedestal with two TESLA® EVSE (Two EVSE per Pedestal):**

- One (1) ClipperCreek ProMountDuo™ Kit, ClipperCreek part number 0300-00-025.
- Two (2) TESLA® EVSE, TESLA® part number 1050067-01-E.
- Two (2) dedicated 208 or 240 VAC branch circuits.\*
- One (1) or Two (2) circuit breakers, appropriately sized with respect to the charging capacity of each EVSE.\*
- Appropriately sized service wiring based on EVSE power requirements (reference EVSE Product manual). Each conductor must have enough length to comfortably pull all the way through and above the top of the pedestal (5 feet is adequate).
- Two (2) Ground Line conductors (one for each EVSE) or a single bonded Ground Line with enough length to comfortably pull all the way through and above the top of the pedestal (5 feet is adequate).
- Conduit sized to fit all conductors.
- Four (4) Anchor Bolts with Nuts and Washers (additional washers may be required for leveling)

CONFIGURATION G

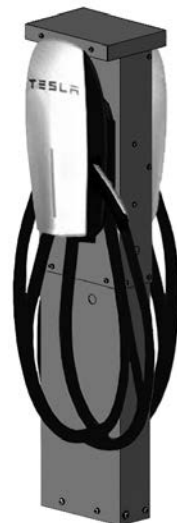

Dual TESLA® EVSE

\* Consult the TESLA® Wall Connector Manual if selecting the TESLA® Load Sharing Option.



## INSTALLATION REQUIREMENTS AND CONFIGURATIONS (continued)

### CONFIGURATION H:

#### Required Equipment for a Combo Dual-Mount Pedestal with one HCS EVSE and one TESLA® EVSE (Two EVSE per Pedestal):

- One (1) ClipperCreek ProMountDuo™ Kit, ClipperCreek part number 0300-00-025.
- One (1) ClipperCreek HCS EVSE, part number is determined by amperage and options selected.
- One (1) TESLA® EVSE, TESLA® part number 1050067-01-E.
- Two (2) dedicated branch circuits, voltages dependent upon the EVSE options selected.\*
- Two (2) circuit breakers, appropriately sized with respect to the charging capacity of each EVSE.\*
- Appropriately sized service wiring based on EVSE power requirements (reference EVSE Product manual). Each conductor must have enough length to comfortably pull all the way through and above the top of the pedestal (5 feet is adequate).
- Two (2) Ground Line conductors (one for each EVSE) or a single bonded Ground Line with enough length to comfortably pull all the way through and above the top of the pedestal (5 feet is adequate).
- Conduit sized to fit all conductors.
- Four (4) Anchor Bolts with Nuts and Washers (additional washers may be required for leveling)

### CONFIGURATION I:

#### Required Equipment for a Combo Dual-Mount Pedestal with one ClipperCreek LCS/ACS and one TESLA® EVSE (Two EVSE per Pedestal):

- One (1) ClipperCreek ProMountDuo™ Kit, ClipperCreek part number 0300-00-025.
- One (1) ClipperCreek LCS/ACS EVSE part number is determined by amperage and options selected.
- One (1) TESLA® EVSE, TESLA® part number 1050067-01-E.
- Two (2) dedicated branch circuits, voltages dependent upon the EVSE option selected.\*
- Two (2) circuit breakers, appropriately sized with respect to the charging capacity of each EVSE.\*
- Appropriately sized service wiring based on EVSE power requirements (reference EVSE Product manual). Each conductor must have enough length to comfortably pull all the way through and above the top of the pedestal (5 feet is adequate).
- Two (2) Ground Line conductors (one for each EVSE) or a single bonded Ground Line with enough length to comfortably pull all the way through and above the top of the pedestal (5 feet is adequate).
- Conduit sized to fit all conductors.
- Four (4) Anchor Bolts with Nuts and Washers (additional washers may be required for leveling).

CONFIGURATION H

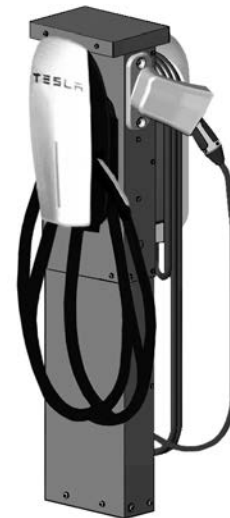

Combo TESLA® EVSE  
and ClipperCreek  
HCS EVSE

CONFIGURATION I

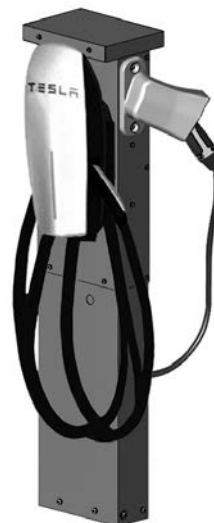

Combo TESLA® EVSE  
and ClipperCreek  
LCS/ACS EVSE

\* Consult the TESLA® Wall Connector Manual if selecting the TESLA® Load Sharing Option.



# PACKING LIST

## 0300-00-025 ProMountDuo™ Pedestal Kit

<u>ITEM REFERENCE</u>	<u>PART NUMBER</u>	<u>QTY</u>	<u>DESCRIPTION</u>
(A)	1003-0046	1	Pedestal Metalwork, Base
(B)	1003-0047	2	Pedestal Metalwork, Bottom Panel
(C)	1003-0048	2	Pedestal Metalwork, Top Panel (RevF)
(D)	1003-0049	1	Pedestal Metalwork, Cap
(E)	4000-0023	34	Machine Screw, Self-Tapping, SST Black, Pan Head, #10-32 Size 1/2" length, T25 Torx
(F)	4000-0024	4	Machine Screw, SST Plated Black Oxide, Pan Head, 1/4-20 Size, 2" Length, T30 Torx
(G)	4000-0025	12	Machine Screw, SST Plated Black Oxide, Pan Head, 1/4-20 Size, 3/4" Length, T30 Torx
(H)	4002-0010	16	Washer, SST Black, 1/4" ID, 1/2" OD
(I)	4002-0011	34	Washer, SST Black, #10 ID, 7/16" OD
(J)	4300-0012	2	Pre-cut 4 3/8" Conduit, Flexible, Liquid Tight, 1/4" Trade Size, Black
(K)	4015-0002	2	Plug, 1.109" Push-in, Black (installed)
(L)	4015-0005	2	Plug, 0.50" Push-in, Black (installed)
(M)	4015-0006	2	Bushing, 1.09" Push-in, Black
(N)	4015-0007	2	Bushing, 0.50" Push-in, Black
(O)	4015-0008	4	Tapered Rubber Plug, 3/16", Black

**NOTE:** The appropriate Conduit fittings and Holsters will be included with your EVSE. The ground lugs will come pre-installed on the Pedestal Top Panels. Item Reference Letters are referred to throughout this Installation Guide.





# HARDWARE

	Front	Side
E x 34		
F x 4		
G x 12		
H x 16		
I x 34		
J x 2		
K x 2		
L x 2		
M x 2		 (Required for TESLA® EVSE only)
N x 2		 (Optional: for TESLA® EVSE only)
O x 4		 (Required For TESLA® EVSE only)

Figure 4

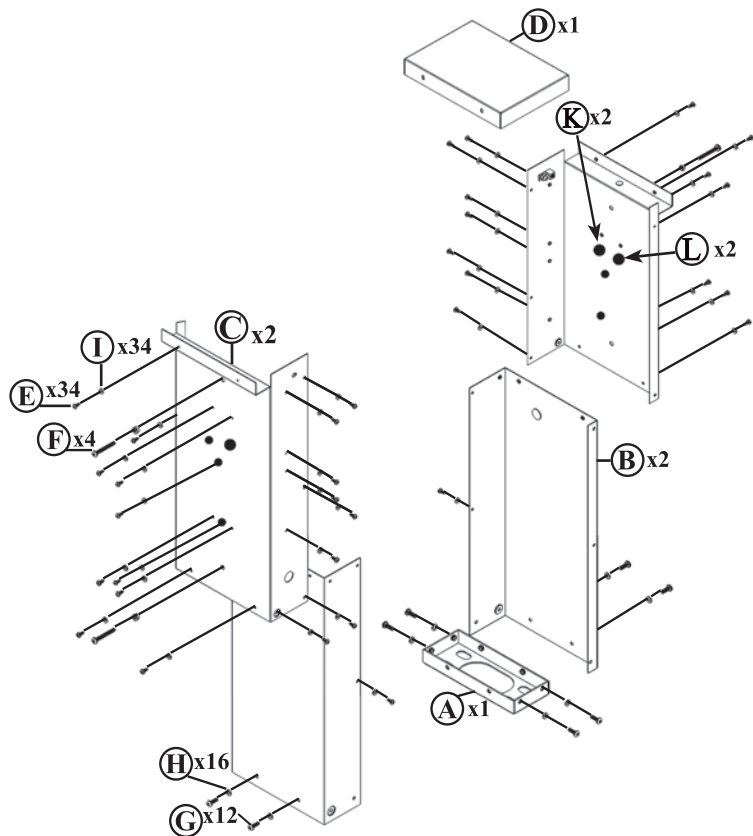

Not shown on exploded view



## **OPTIONAL ORDERABLE ITEMS**

### **0300-06-000 120V Ground Fault Receptacle Kit (Optional)\***

<u><b>PART NUMBER</b></u>	<u><b>QTY</b></u>	<u><b>DESCRIPTION</b></u>
4015-0002	1	Plug, Knockout Bushing, 1.109" OD, 3/4" Trade Size Aperture
4301-0000	1	GFCI Ground Fault Receptacle, 15A, 125V, NEMA 5-15R, Single Socket with Switch
4301-0001	1	Gang Box, Single, Silver Metal
4301-0002	1	Weatherproof Receptacle Cover, Clear, Single Gang, 2 3/4" Depth

\*The Ground Fault Receptacle Kit includes a 120VAC GFCI receptacle and housing. It may be installed at the knock-outs located on the narrow sides of the Top Panels.

**Refer to the Ground Fault Receptacle Kit Installation Guide for installation instructions.**



## INITIAL PEDESTAL INSTALLATION

### 1. CONCRETE PAD REQUIREMENTS

The location, dimensions, and composition of the concrete pad underlying the pedestal should always adhere to local building codes. The following dimensions are minimum recommended values. Always verify that installation plans adhere to local code requirements prior to proceeding.

- The pad area must be a minimum of 18" to a side.
- The concrete must be poured a minimum depth of 18".
- If there is no bumper block, the center of the pedestal base should be situated 36" behind the curb.
- If a bumper block is in place, the center of the pedestal base should be situated 12" behind the curb.
- WARNING: Pull wires an extra 5 feet from conduit in order to facilitate installation.**

Figure 5

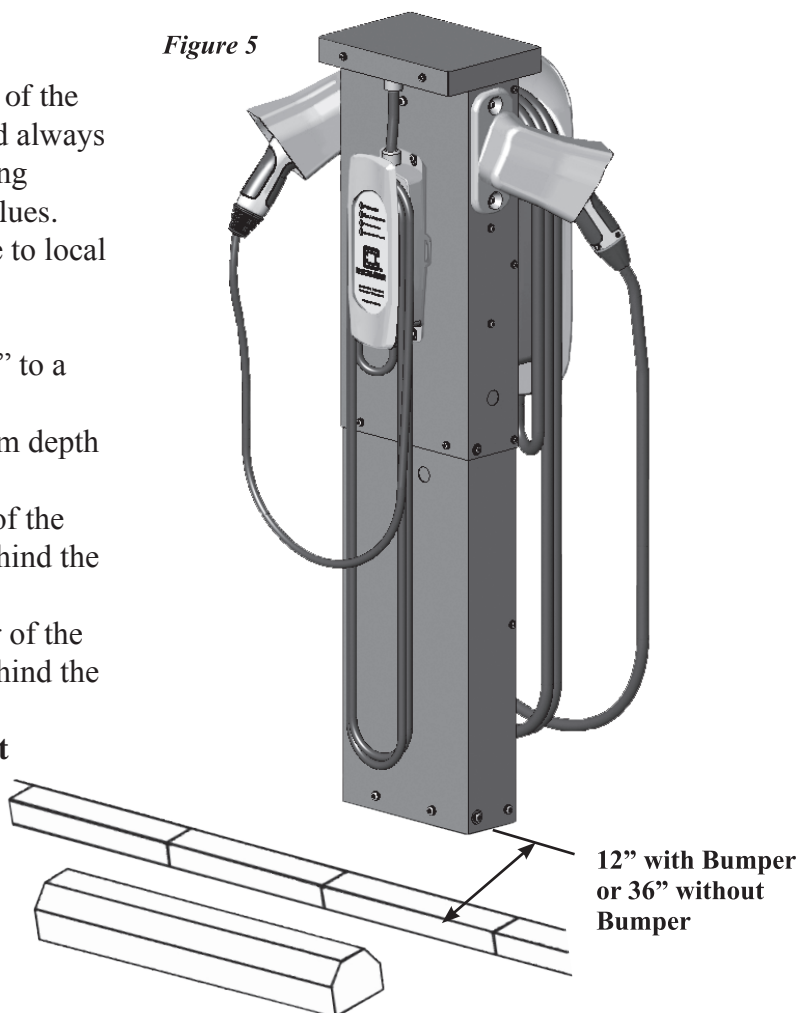

### 2. ANCHOR BOLT PLACEMENT

- A cardboard base template is provided within the ProMountDuo™ internal packaging. This template can be punched out from either the Base or the Cap cardboard boxes.
- A minimum of four (4) anchor bolts must be embedded in the concrete pad for the purposes of securing the pedestal post. The pedestal base is designed for anchor bolts to be centered in an approximately 6.5" x 1.75" rectangular pattern as shown in **Figure 6**.
- The anchor bolts, nuts and washers used for the installation of the pedestal base are not included in the pedestal kit and must be purchased separately. Either  $\frac{3}{8}$ ",  $\frac{1}{2}$ ", or  $\frac{5}{8}$ " anchor bolts can be used. Always check against local building codes as they may vary.

Figure 6

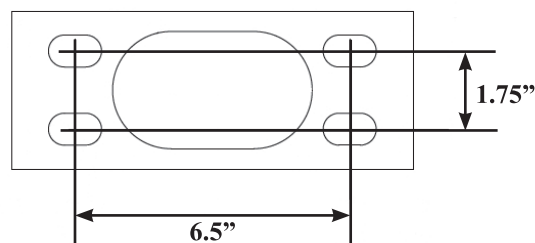



## INITIAL PEDESTAL INSTALLATION (continued)

### 3. MOUNT THE PEDESTAL BASE

Once the concrete pad with anchor bolts has been prepared and the three service conductors have been pulled through the underground conduit, the Pedestal Base (A) may be placed.

- a. Feed the three service conductors up through the inside of the large center hole in the Pedestal Base (A). The conductors must be of sufficient length to pass beyond the top of the pedestal so that final connections can be worked with comfortably at a later step.
- b. Leveling adjustments must be made at this time. Washers (not included) can be used under the Base for leveling and/or to prevent water accumulation.
- c. Align the four Pedestal Base obround holes with the four anchor bolts and ease into place.
- d. Secure the Pedestal Base to the concrete anchor bolts using appropriately sized nuts and washers (not included) as shown in **Figure 7**.
- e. **Tighten the Anchor Bolts as much as possible.** See **Figure 8**.

*Figure 7*

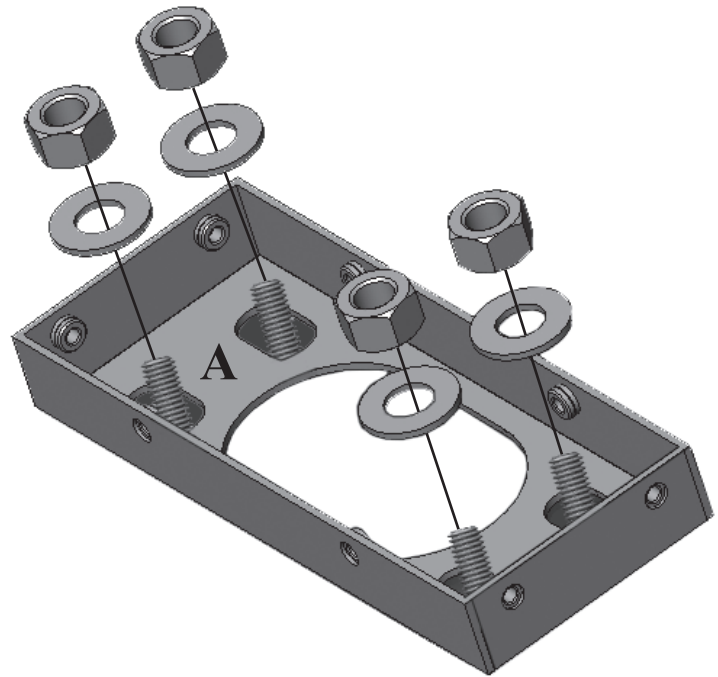

*Figure 8*

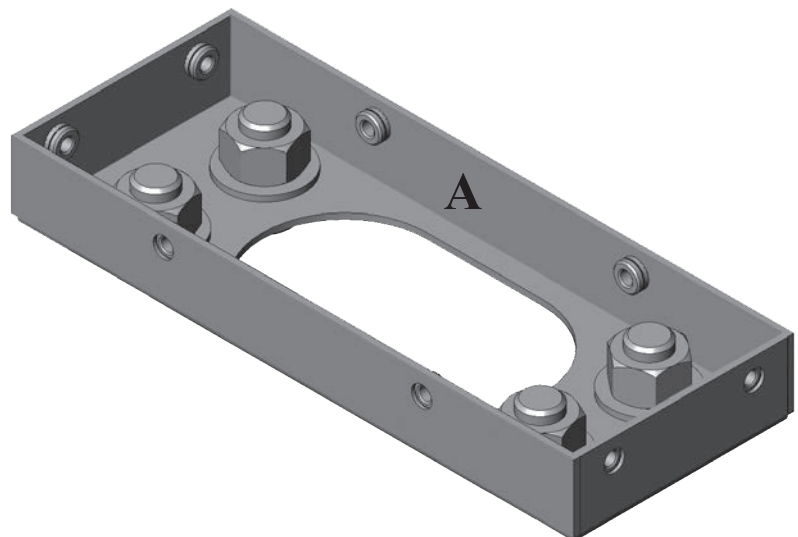



## INITIAL PEDESTAL INSTALLATION (continued)

### 4. INSTALL THE BOTTOM PANELS

- Place a #10 washer (**I**) around the shaft of each of the thirty-four (34) #10 Torx T25 screws (**E**).
- Place a ¼" washer (**H**) around the shaft of each of twelve (12) ¼-20, ¾" long Torx T30 screws (**G**), as well as the four (4) ¼-20, 2" long Torx T30 screws (**F**).
- Set aside the four (4) longer 2" ¼-20 screw and washer sets (**F**) & (**H**). These will be needed later.
- Align the screw holes on the front of the first Bottom Panel (**B**) with the corresponding screw holes on the long edge of the Pedestal Base (**A**), making sure that the knockout is on the top side.
- Secure only the front of the first Bottom Panel to the Base with two (2) of the ¾" long ¼-20 screw and washer sets (**G**) & (**H**) using a T30 Torx driver as shown in **Figure 9**.
- Check level carefully along the top edge of the first Bottom Panel before installing the second Bottom Panel. Reseat Pedestal Base as needed, making sure the **anchor bolts are tightened as much as possible**.
- To install the second Bottom Panel (**B**), gently nest the narrow edges of each Bottom Panel between the Pedestal Base and the opposing Panel.
- Secure both Bottom Panels to the Pedestal Base with six (6) additional ¾" long ¼-20 Torx T30 screw and washer sets (**G**) & (**H**) as shown in **Figure 10**.
- Secure the middle of both Bottom Panels with two (2) of the #10 Torx T25 screw and washer sets (**E**) & (**I**) as shown in **Figure 11**.
- Tighten securely, but do not use such force that would cause the Panel surface to indent.
- Note: The Bottom Panels are powder coated inside AND outside for extra protection near the concrete pad.**

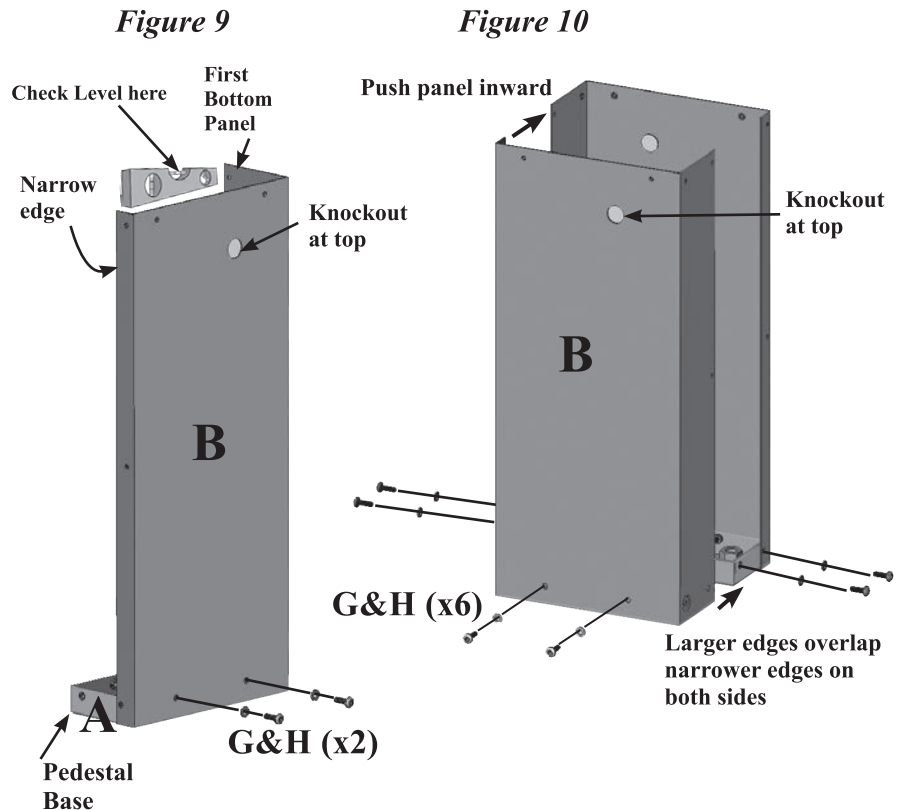
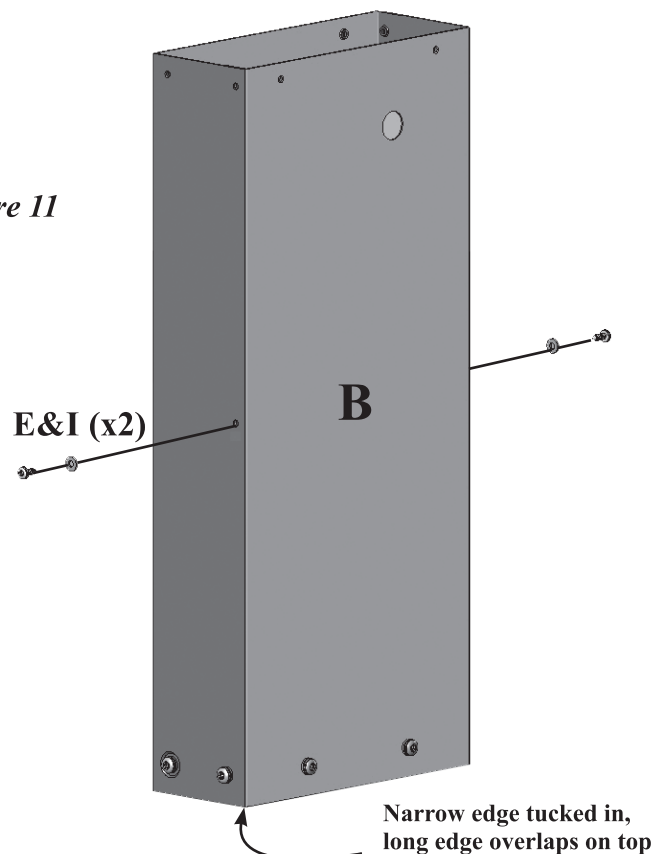

Figure 11





# INITIAL PEDESTAL INSTALLATION (continued)

## 5. REMOVE KNOCKOUTS

**CAUTION: BE CAREFUL TO CHOOSE THE CORRECT KNOCKOUT POSITION FOR THE PARTICULAR CONFIGURATION PER FIGURE 12.**

### a. LCS/ACS Series ONLY:

- Remove the knockout under the overhang of the Top Panel (C) on the side to which the EVSE is to be mounted (or both sides if Dual-Mounting).

**NOTE: In Step 6, make sure that this Top Panel is placed on the appropriate side of the Pedestal so that the LCS/ACS EVSE will be facing the correct parking spot.**

**WARNING: If the wrong knockout is accidentally removed, the open holes must be plugged with plastic caps (not included).**

### b. HCS-Series ONLY:

- Remove the knockout on the side to which the HCS EVSE is to be mounted (or both sides if Dual Mounting).
- The HCS EVSE will come with an appropriately sized Conduit fitting on the end of the flexible conduit.
- Remove this fitting from the end of the flexible Conduit and install it onto the Bottom Panel hole(s) at this time, making sure the sealing washer is on the outside of the pedestal end of the conduit as shown in **Figure 13**.

### c. Optional GFCI Kit ONLY:

- Remove the knockouts on the narrow side of the applicable Top Panel.

### d. TESLA® EVSE part number 105006701-E ONLY:

- This configuration does not require knockout removal (Caps L and K are removed in lieu of knockouts).

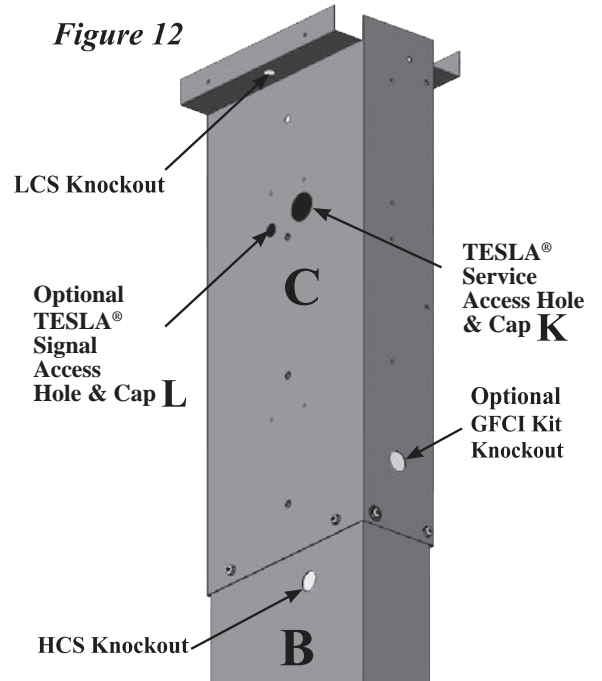
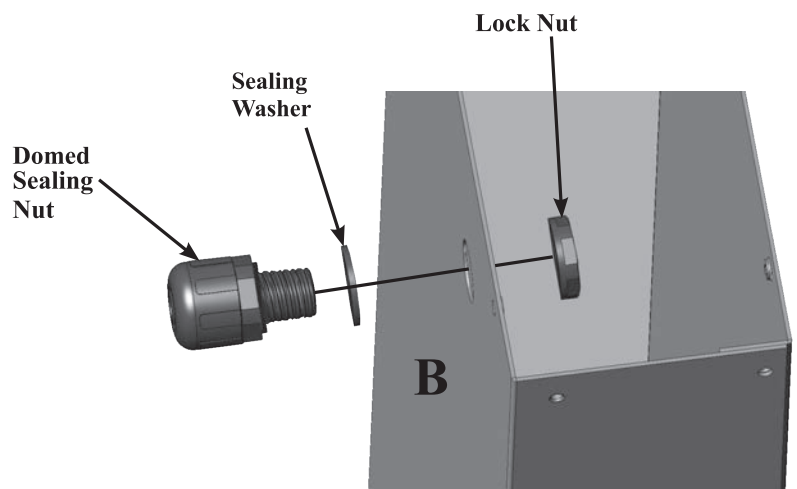

Figure 13 - HCS Series only





## INITIAL PEDESTAL INSTALLATION (continued)

### 6. INSTALL THE TOP PANELS

- a. Align the screw holes of the first Top Panel (C) with the corresponding screw holes on the Bottom Panel (B). The Top Panel should be overlapping the Bottom Panel on all sides.
- b. Secure only the long front edge of the first Top Panel to the Bottom Panel with two (2) of the #10 screw and washer sets (E) & (I) using a T25 Torx driver as shown in **Figure 14**. Tighten securely, but do not use such force that would cause the Panel surface to indent.

**C. WARNING:** Pull the wires over the top of the first Top Panel so that they will be easily accessible in later steps.

*Figure 14*

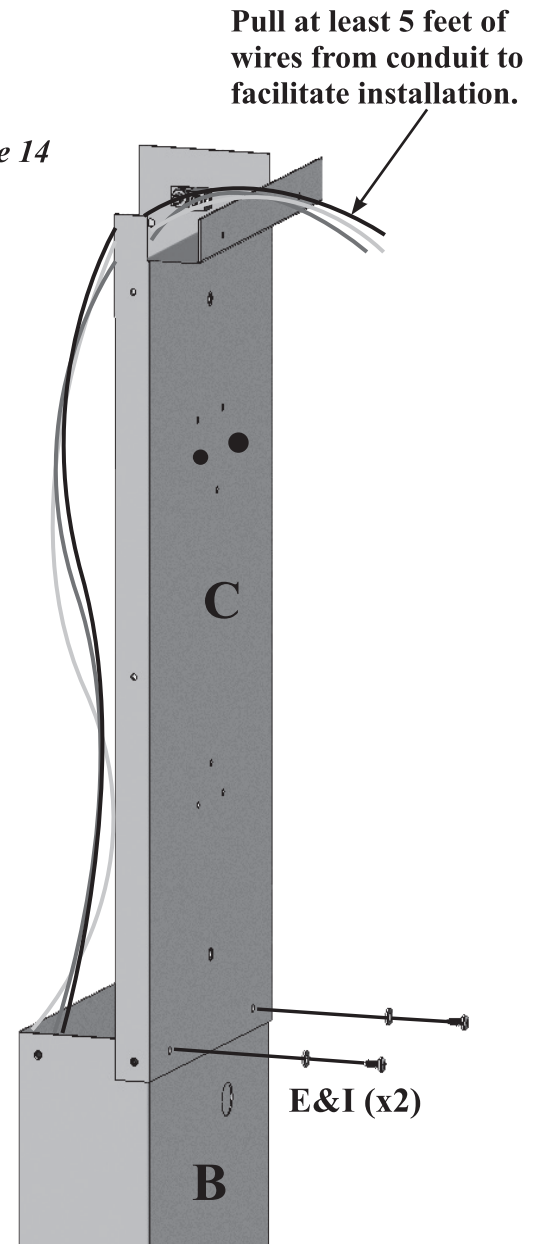



## INITIAL PEDESTAL INSTALLATION (continued)

- d. To install the second Top Panel (C), gently nest the narrow edge of the second Top Panel over the top of the Bottom Panel (B) and tuck inside the opposing Top Panel.
- e. Finish securing the lower edge of both Top Panels to the Bottom Panels using six (6) #10 screw and washer sets (E) & (I) as before. Tighten securely, but do not use such force that would cause the Panel surface to indent. See **Figure 15**.
- f. Secure the middle and top of both Top Panels with four (4) of the #10 screw and washer sets (E) & (I) to increase stability before the next step. Tighten securely, but do not use such force that would cause the Panel surface to indent. See **Figure 16**.
- g. Install the optional GFCI kit(s) at this time per the instructions found in the GFCI kit box(es).

**NOTE: The GFCI areas will be very difficult to access after this step.**

Figure 15

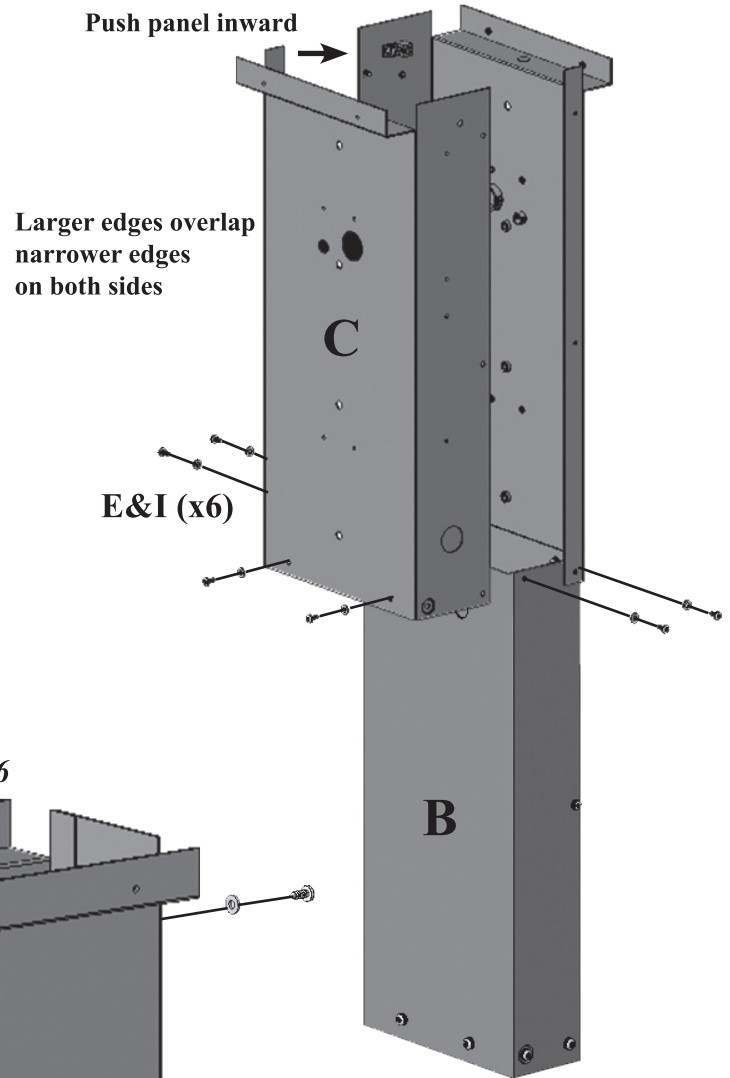
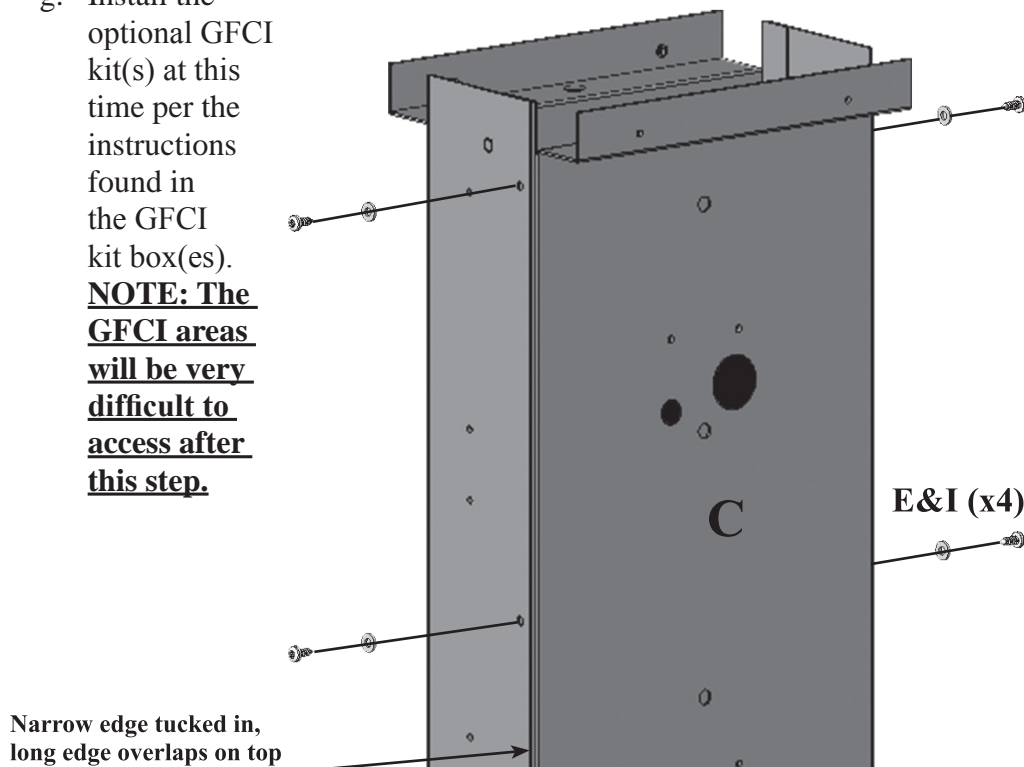

Figure 16







## INITIAL PEDESTAL INSTALLATION (continued)

### 7. INSTALL THE HOLSTER(S)

- a. If installing only TESLA® EVSE, plug ALL eight (8) holster holes with #10 screw and washer sets (E) & (I) then proceed to the TESLA® EVSE installation chapter.
- b. If installing a ClipperCreek EVSE, a Holster for the SAE-J1772™ Vehicle Connector will accompany each new EVSE. Remove the Holster(s) from the EVSE packaging. **WARNING: Discard the two wood screws used for wall mounting the Holster (these screws accompany the holster packaging). DO NOT USE WOOD SCREWS ON THIS PEDESTAL INSTALLATION.**
- c. Align the screw holes on the Holster with the corresponding screw holes on the appropriate side of the Top Panel (C). Make sure the opening of the Holster is facing the same side and directly to the left of the corresponding EVSE position. There are two Holster positions to choose from for customer convenience. The top position is the standard mounting location.
- d. Secure the Holster to the Top Panel with two (2) of the #10 screw and washers sets (E) & (I) and tighten securely as shown in **Figure 17**.
- e. Repeat on opposite side of pedestal for a Dual Mount system.
- f. Plug any unused holster holes with #10 screw and washer sets (E) & (I) as shown. **Note: Figure 18 is Single Mount; there will be another holster on the opposite side if installing a Dual Mount system.**

*Figure 17*

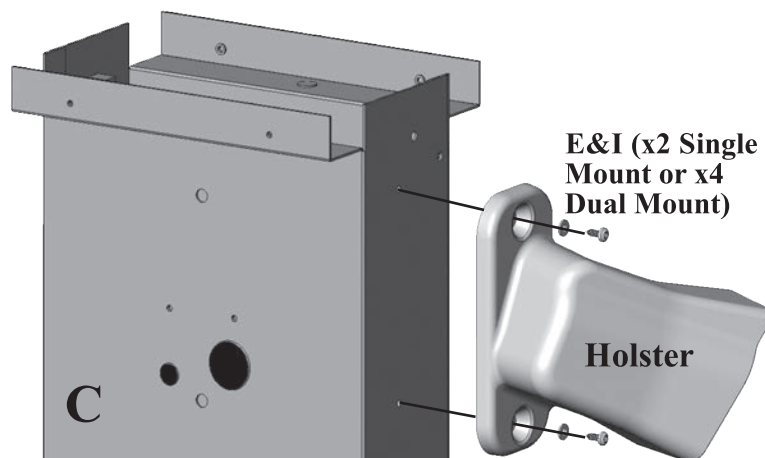

*Figure 18*

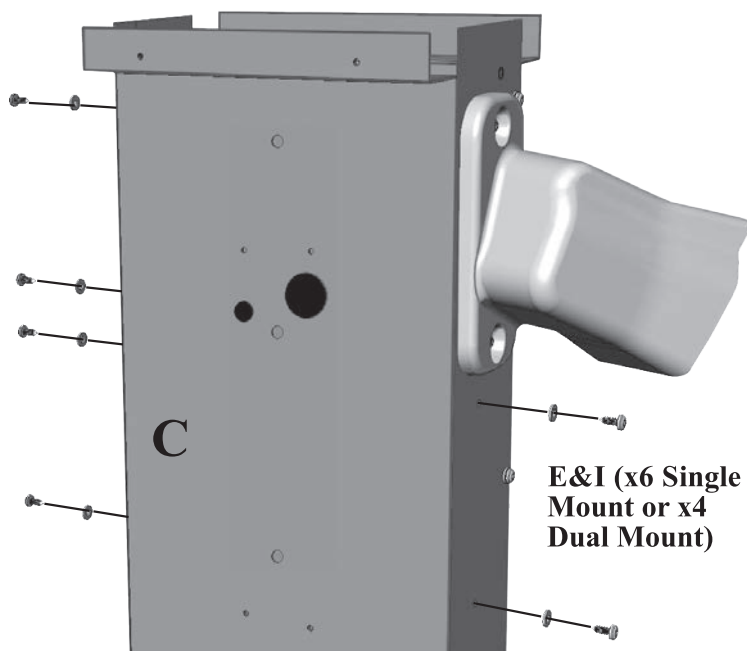

THE INITIAL PEDESTAL INSTALLATION IS NOW COMPLETE. PLEASE REFER TO THE HCS, LCS/ACS AND/OR TESLA® EVSE INSTALLATION SECTIONS ACCORDING TO THE CONFIGURATIONS DESIRED.



## HCS EVSE INSTALLATION

### 1. PREPARE THE HARDWARE

- a. Retrieve two (2) 1/4-20 x 2" Torx T30 screw and washer sets (F) & (H) that were previously set aside.
- b. Locate the correct HCS plastic angle washers. These washers are included with the HCS EVSE and do not accompany this kit. There are two different styles of HCS plastic angle washers. The correct style to use with the Pedestal is the Perpendicular Screw Mount as shown in **Figure 19**. **WARNING: Discard the two wood screws used for wall mounting the HCS EVSE (these screws accompany the HCS packaging). DO NOT USE WOOD SCREWS ON THIS PEDESTAL INSTALLATION.**
- c. Place an HCS Perpendicular Screw Mount plastic angle washer around the shaft of two (2) of the 1/4-20 x 2" Torx T30 screw and washer sets (F) & (H), just below the metal washers. Keep these nearby for use on upcoming steps.

### 2. CUT THE FLEXIBLE CONDUIT TO LENGTH

- a. Remove the packaging from the HCS EVSE.
- b. Trim the flexible Conduit to 6" as shown in **Figure 20**. **DO NOT CUT OR DAMAGE THE WIRES OR WIRE INSULATION.**
- c. Leave the EVSE service conductors full length for pulling to the top of the Pedestal.

Figure 19

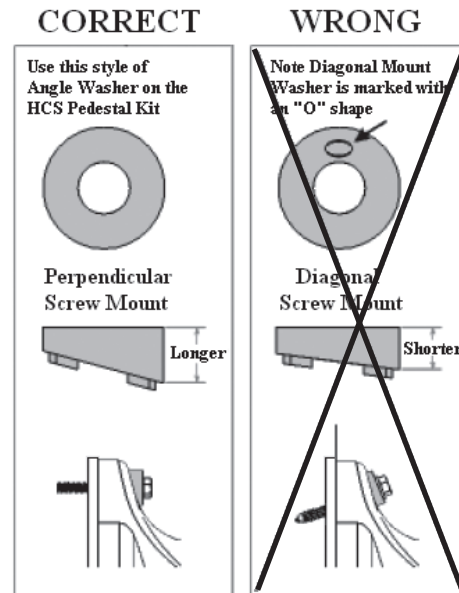
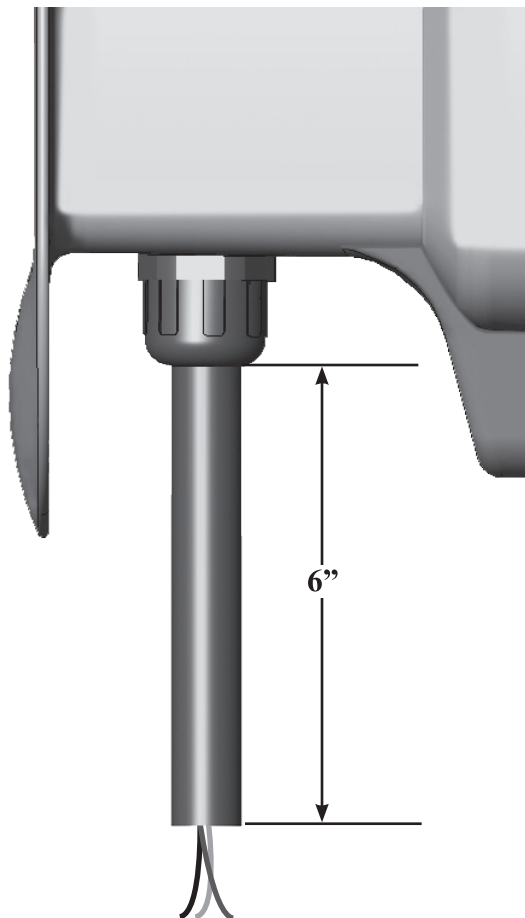

Figure 20





## HCS EVSE INSTALLATION (continued)

### 3. INSTALL THE HCS EVSE

- a. For ease of assembly, unwrap the cable and stow the SAE-J1772™ Vehicle Connector into the Holster as shown. The button on the Connector does not need to be pressed, simply insert until the audible click is heard to lock it into place. See **Figure 21**. Coil the remaining cable on the ground and out of the way.
- b. While supporting the HCS EVSE horizontally, carefully insert the wires through the HCS Conduit fitting on the Bottom Panel (**B**). Insert the wires so that they will tend to run upward inside the pedestal for easier access at a later step.
- c. Tighten the Conduit Fitting around the Conduit.
- d. Tilt the HCS EVSE upward to the upright mounting position. Align the two screw holes on the top and bottom of the HCS EVSE with the corresponding threaded inserts on the Top Panel (**C**) per **Figure 22**.

*Figure 21*

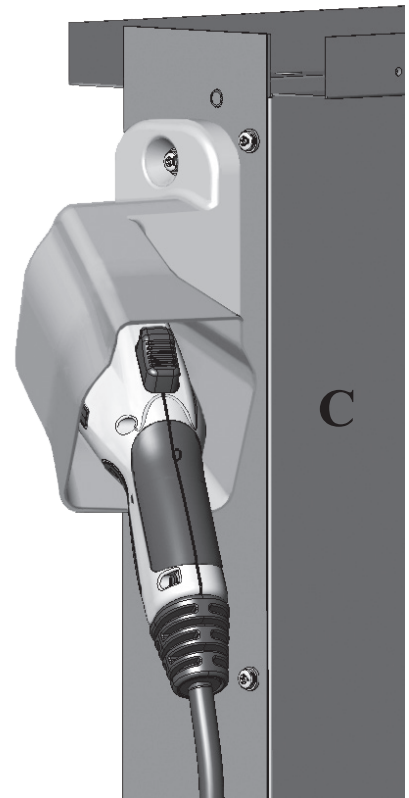

*Figure 22*

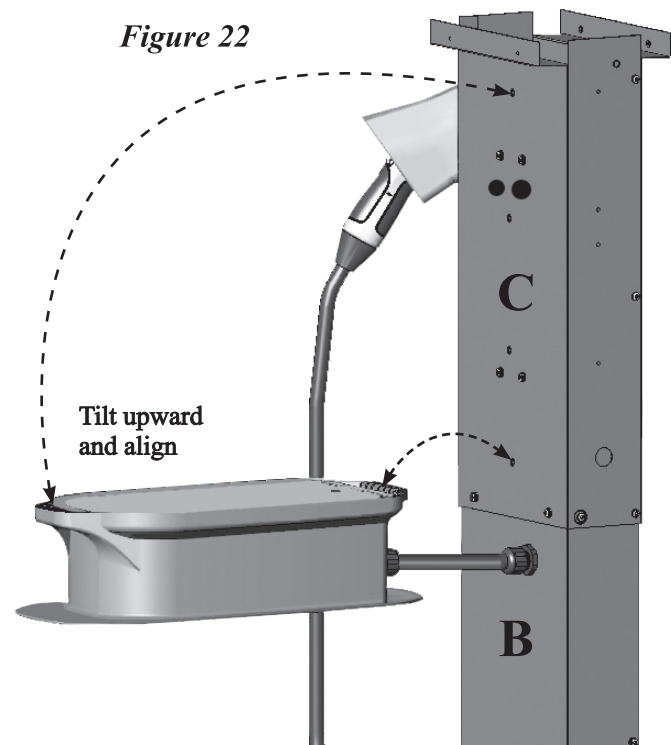



## HCS EVSE INSTALLATION (continued)

- e. Use a T30 Torx driver to secure the top of the HCS EVSE using one (1) 1/4-20 x 2" Torx screw and washer set (F) & (H) with the HCS Plastic Angle Washer as shown. Do not over-tighten. Refer to **Figure 23**.

Figure 23

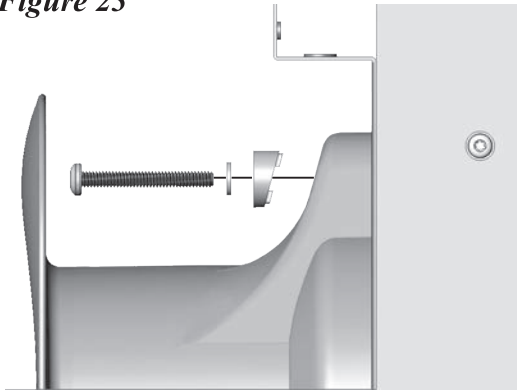
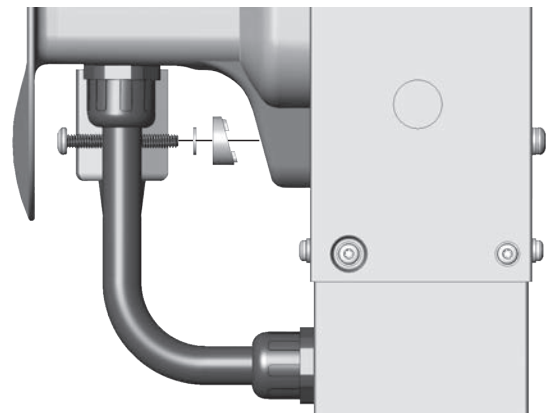

Figure 24



- f. Secure the bottom of the HCS EVSE using one (1) 1/4-20 x 2" Torx screw and washer set (F) & (H) with the HCS Plastic Angle Washer. Refer to **Figure 24**.
- g. **Recheck and re-tighten the Conduit Fitting around the flexible conduit to ensure a watertight installation.**
- h. Loosely wrap the vehicle charging cable around the HCS.

### 4. CONNECT THE SERVICE CONDUCTOR WIRING

- a. The ground conductor and ground lug connections inside the Pedestal Post must be completed at this time. The ground lugs have a 3/16" Hex screw (Allen screw) and are already installed inside the Top Panels (C) as shown in **Figure 25**.

**NOTE: The top access hole may be blocked on upcoming steps.**

- b. Connect the remaining service wires per the HCS User's Manual.

Figure 25

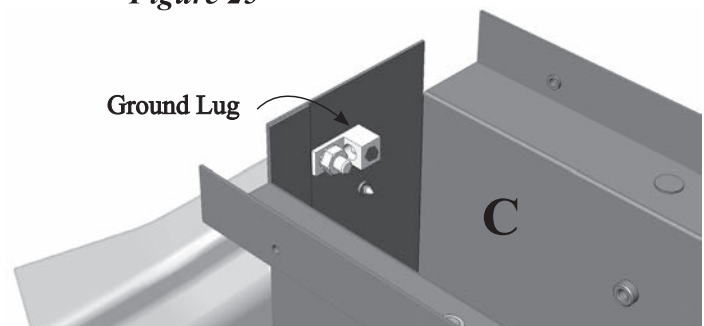

### 5. CHECK CONFIGURATIONS

- a. If a Single-Mount HCS Configuration is desired, please proceed to the Final Pedestal Installation section.
- b. If a Dual-Mount HCS Configuration is desired, repeat the HCS EVSE Installation section on the opposite side of the pedestal.
- c. If an LCS/ACS EVSE will be placed on the opposite side, refer to the LCS/ACS EVSE Installation section.
- d. If a TESLA® EVSE will be placed on the opposite side, refer to the TESLA® EVSE Installation section.

INSTALLATION OF THE HCS EVSE IS NOW COMPLETE. PLEASE REFER TO THE HCS USER MANUAL FOR TROUBLE-SHOOTING AND ADDITIONAL INFORMATION.



## LCS/ACS EVSE INSTALLATION

### 1. INSTALL THE LCS/ACS EVSE

- b. Retrieve two (2) of the ¼-20 x 2” Torx T30 screw and washer sets (F) & (H) that were previously set aside.
- c. Insert the screws into the upper and lower threaded holes in the Top Panel (C) on the side of the pedestal where the LCS/ACS EVSE will be installed. These holes are intended for an alternate configuration and must be plugged prior to the LCS/ACS EVSE installation. See **Figure 26**.
- d. For ease of assembly, unwrap the cable and stow the SAE-J1772™ Vehicle Connector into the Holster as shown. The button on the Connector does not need to be pressed, simply insert until the audible click is heard to lock into place. Refer to **Figure 27**. Coil the remaining cable on the ground and out of the way.
- e. The LCS/ACS EVSE will come with an appropriately sized Conduit Fitting on the end of the Flexible Conduit. Remove this fitting from the conduit and install it onto the Top Panel at this time, making sure the sealing washer is on the outside of the pedestal as shown in **Figure 28**.
- f. Carefully remove the entire length of the pre-installed Flexible Conduit from the LCS/ACS EVSE by loosening the domed sealing nut to pull out the Conduit.
- f. Locate one piece of the 4<sup>3⁄8</sup>” long pre-cut LCS/ACS Conduit (J) from the ProMountDuo™ packaging.
- g. Install the 4<sup>3⁄8</sup>” Flexible Conduit onto the LCS/ACS EVSE. **WARNING: IT IS VERY IMPORTANT TO INSTALL THE CONDUIT FITTING SECURELY TO ENSURE A WATERTIGHT FIT.** See **Figure 29**.
- h. While supporting the LCS/ACS EVSE, carefully thread the wires into the LCS/ACS Conduit Fitting on the Top Panel.
- i. Tighten the Conduit Fitting around the Conduit. **WARNING: IT IS VERY IMPORTANT TO TIGHTEN THE CONDUIT FITTING SECURELY TO ENSURE A WATERTIGHT INSTALLATION.**

Figure 26

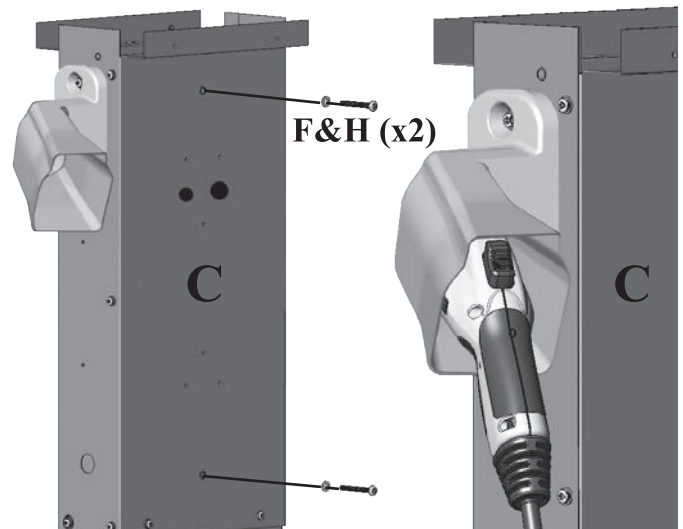

Figure 27

Figure 28

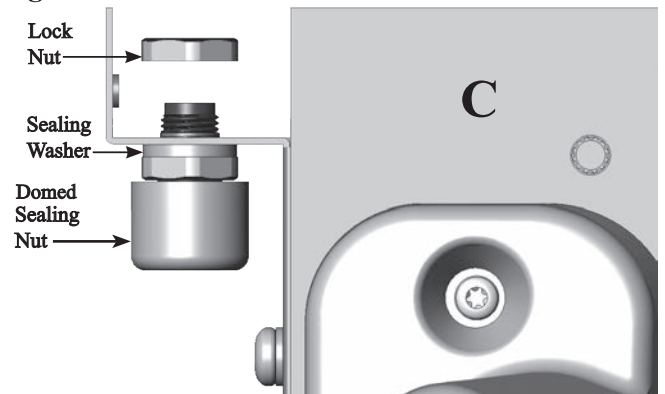
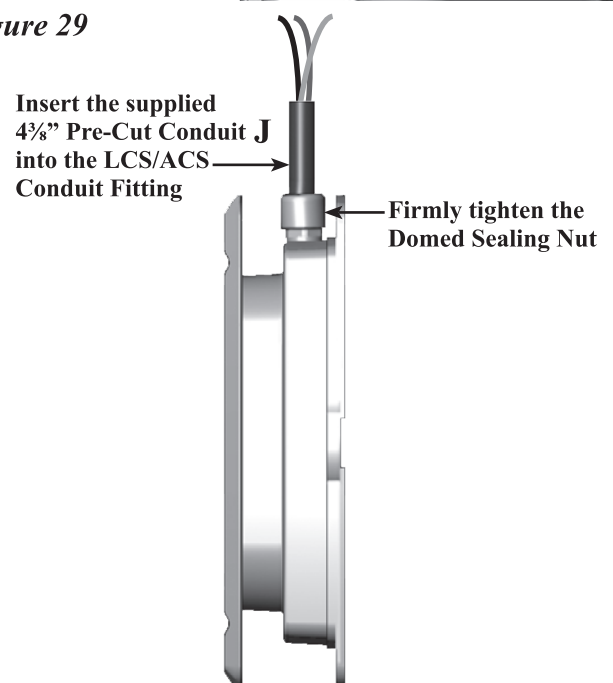

Figure 29





### LCS/ACS EVSE INSTALLATION (continued)

- j. Align the four keyholes on the top and bottom of the LCS/ACS EVSE with the corresponding screw holes in the Top Panel (C). The tops of the keyholes are the preferred locations to align with so that the washers will grip more of the surface of the LCS/ACS EVSE as shown.
- k. Secure the top of the LCS/ACS EVSE using a T25 Torx driver and two (2) #10 Torx screw and washer sets (E) & (I) as shown in **Figure 30**. Do not fully tighten.
- l. Secure the bottom of the LCS/ACS EVSE using the remaining two (2) #10 Torx screw and washer sets (E) & (I). Do not fully tighten.
- m. Slide the keyhole slots of the LCS/ACS onto the semi-tightened screws. Make sure the LCS/ACS is level, then fully tighten all 4 screws. Do not over tighten.
- n. Recheck and re-tighten the Conduit Fitting around the Conduit if necessary.
- o. **WARNING! SILICONE MUST BE USED TO SEAL BETWEEN THE WIRES ON THE INSIDE OF THE LCS/ACS CONDUIT FOR ADDITIONAL SECURITY AGAINST WATER INTRUSION AS SHOWN IN FIGURE 31.**
- p. Loosely wrap the vehicle charging cable around the body of the LCS/ACS.

Figure 30

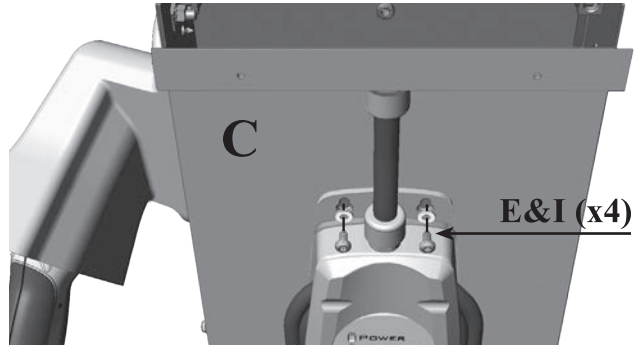

### 3. CONNECT THE SERVICE CONDUCTOR WIRING

- a. The ground conductor and ground lug connections inside the Pedestal Post must be completed at this time. The ground lugs have a 3/16" Hex screw (Allen screw) and are already installed inside the Top Panels (C) as shown in **Figure 32**.

**NOTE: The top access hole may be blocked on upcoming steps.**

- b. Connect the service conductor wiring per the LCS/ACS User's Manual.

### 4. CHECK CONFIGURATIONS

- a. If a Single-Mount LCS/ACS Configuration is desired, please proceed to the Final Pedestal Installation section.
- b. If a Dual-Mount LCS/ACS EVSE Configuration is desired, repeat the LCS/ACS EVSE Installation section on the opposite side of the pedestal.
- c. If an HCS EVSE will be placed on the opposite side, refer to the HCS EVSE Installation section.
- d. If a TESLA® EVSE will be placed on the opposite side, refer to the TESLA® EVSE Installation section.

Figure 31

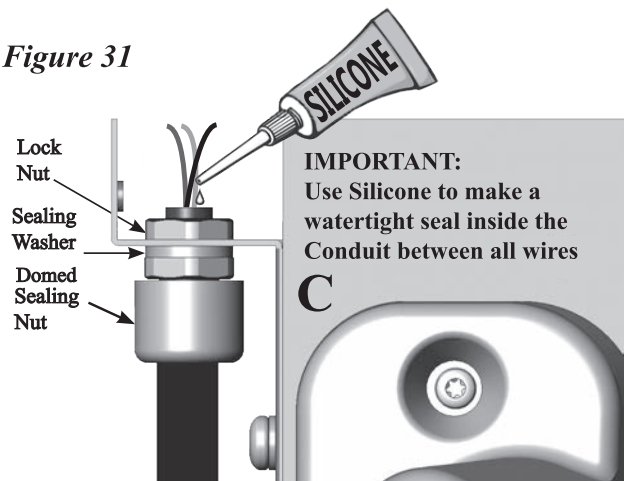
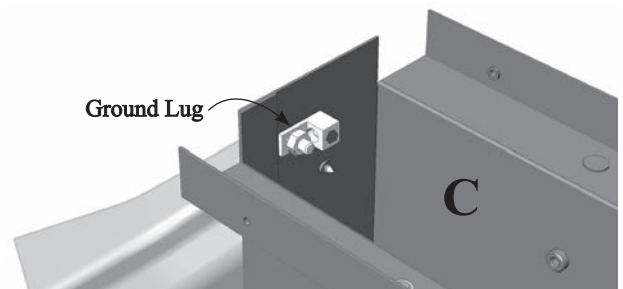

Figure 32



INSTALLATION OF THE LCS/ACS EVSE IS NOW COMPLETE. PLEASE REFER TO THE LCS/ACS USER MANUAL FOR TROUBLE-SHOOTING AND ADDITIONAL INFORMATION.



## TESLA® EVSE INSTALLATION

### 1. PREPARE THE TESLA® EVSE AND MOUNTING COMPONENTS

- a. The TESLA® EVSE shipping box contains additional components that will be used to mount the TESLA® EVSE to the PMD-10 Pedestal. Refer to **Figure 33**.

If any of the following components are damaged or missing, please contact TESLA® according to the most recent information in the TESLA® EVSE Manual.

**WARNING: DO NOT USE THE TOP ENTRY BRACKET MOUNTING SCREWS IN THE TESLA® EVSE SHIPPING BOX (DO NOT USE WOOD SCREWS ON THIS PEDESTAL INSTALLATION). USE ONLY THE 1/4-20, 3/4" LONG TORX T30 SCREW AND WASHER SETS (G) & (H).**

*Figure 33*

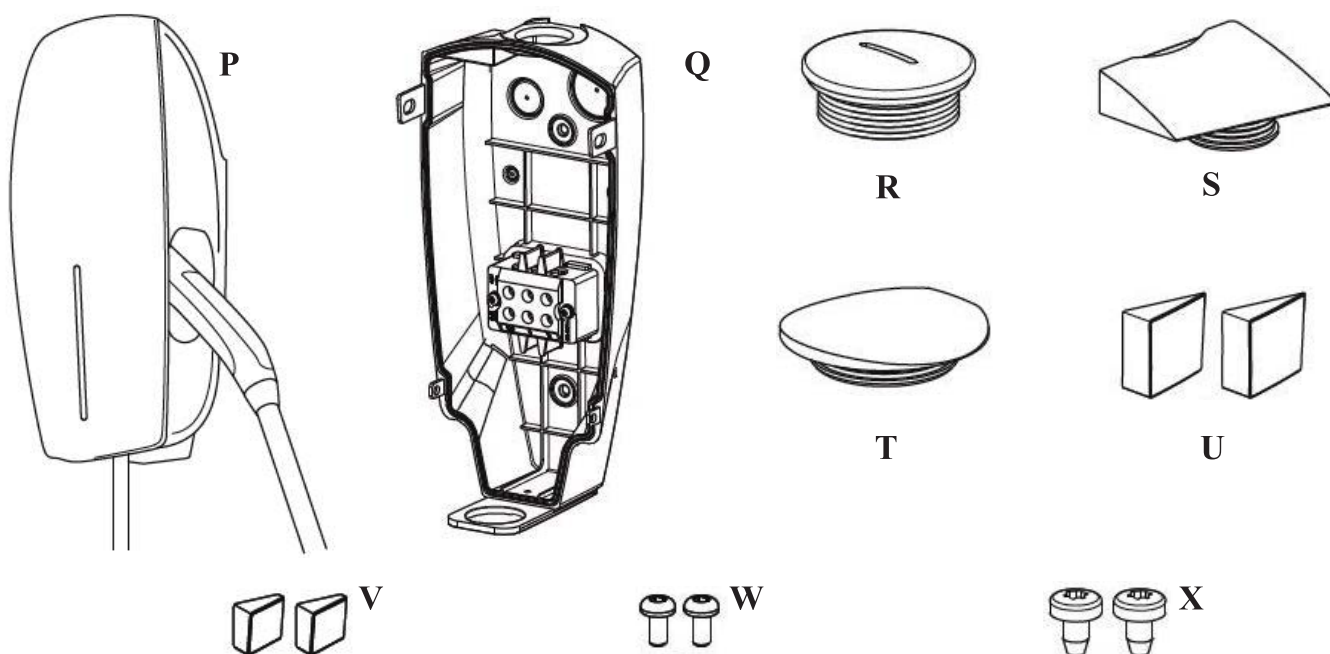

#### ITEM DESCRIPTION (xQuantity):

- **P.** TESLA® EVSE (aka TESLA® Wall Connector)
- **Q.** Top Entry Bracket (x1)
- **R.** Bottom Entry Power Conduit Plug (x1)
- **S.** Top Entry Signal Conduit Plug (x1)
- **T.** Top Entry Power Conduit Plug (x1)
- **U.** Top Bracket-to-Housing Screw Covers (x2)
- **V.** Bottom Bracket-to-Housing Screw Covers (x2)
- **W.** Bottom Bracket-to-Housing Screws (x2)
- **X.** Top Bracket-to-Housing Screws (x2)
- **Y.** T20 Sealing Cover Screws (installed, x6)
- **Z.** T10 Outer Cover Screw (installed, x1)

**NOTE:** Additional hardware is included in the PMD-10 packaging (refer to Figure 4 on page 17 of this manual)



## TESLA® EVSE INSTALLATION (continued)

### 2. PREPARE THE SIDE OF THE PEDESTAL ON WHICH THE TESLA® EVSE WILL BE MOUNTED

- Remove the large and the small plastic caps (**K**) & (**L**) as shown in **Figure 34**.
- Install the large 1.09” Service Bushing (**M**) in the open hole to prevent wire rubbing as shown in **Figure 35**.
- Optional:** If the Load Sharing option will be utilized, place the 0.50” Signal Bushing (**N**) in the open hole to prevent wire rubbing per **Figure 36**. If Load Sharing will **not** be used, leave the small hole open.
- Install the Rubber Plugs (**O**) into the two extruded holes by inserting the smallest end first. Pull through the inside of the pedestal until the large end is flush with the outer surface as shown in **Figure 35**.
- Retrieve two (2) of the 1/4”-20 x 2” Torx T30 screw and washer sets (**F**) & (**H**) that were previously set aside. Insert the screws into the upper and lower threaded holes in the top panel as shown in **Figure 35**. These holes are intended for an alternate configuration and must be plugged prior to the TESLA® EVSE installation.

Figure 34

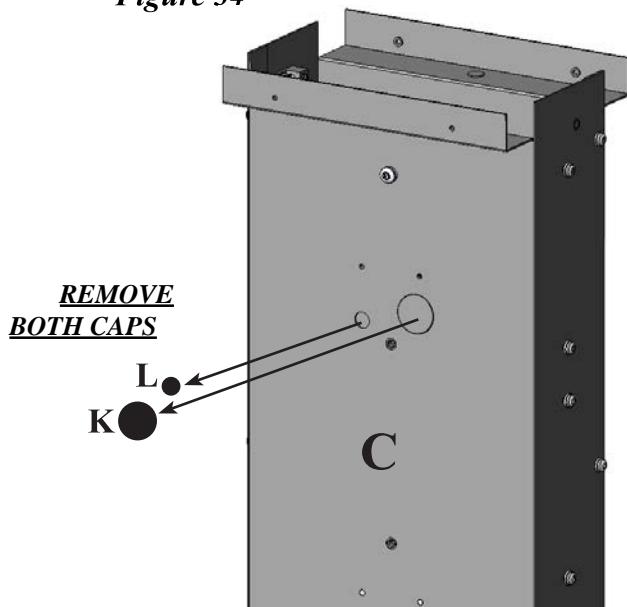

Figure 35

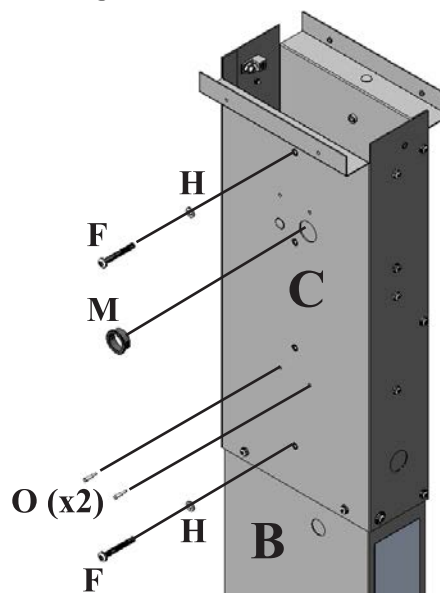
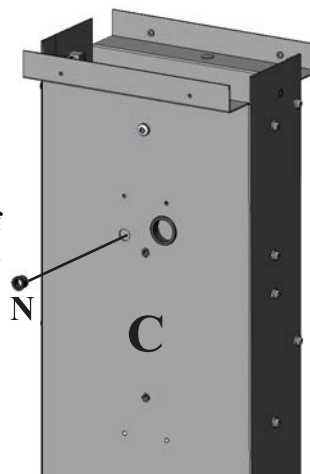

Figure 36 - Load Sharing Option Only

**Optional:** Install the small 0.50” bushing only if utilizing the Load Sharing Option.







## TESLA® EVSE INSTALLATION (continued)

### 3. INSTALL THE TOP ENTRY BRACKET (Q)

- Pop out the larger Service hole knockout
- If Load Sharing will be utilized, pop out the small Signal hole knockout. Otherwise leave this area intact.
- Locate two (2) of the 1/4-20, 3/4" long Torx T30 screw and washer sets (G) & (H) (part of PMD-10 kit).
- Install the Top Entry Bracket (Q) onto the Top Panel (C) of the desired side of the pedestal as shown in **Figure 37**.
- Tighten both screw and washer sets securely.
- Install the Top Entry Signal Conduit Plug (S) and push downward until flush.
- Install the Top Entry Power Conduit Plug (T) and push downward until flush.

Figure 37

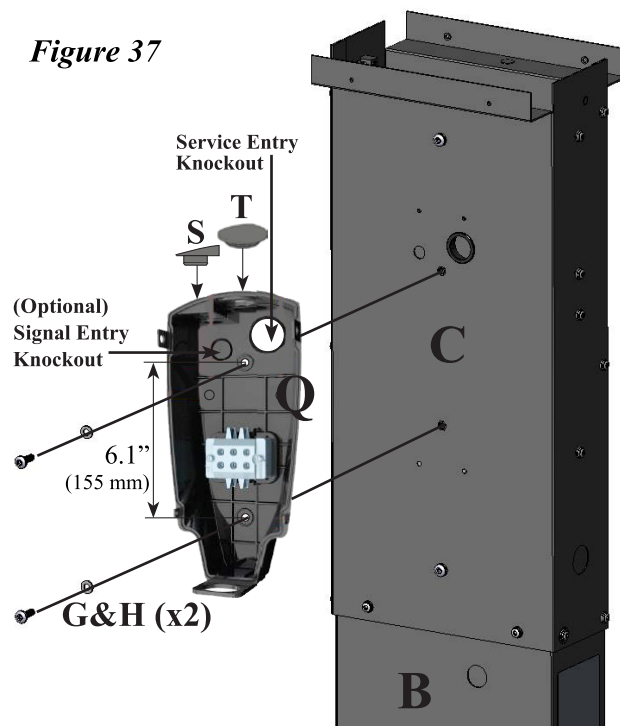

### 4. PREPARE THE TESLA® WALL CONNECTOR EVSE (P)

- Use a T10 Torx driver to remove the screw (Z) at the bottom of the outer cover. Carefully disengage the snaps on the sides and top using a flathead screwdriver and completely remove the cover. Save the screw and cover for reassembly. See **Figure 38**.
- Use a T20 security pin Torx driver to remove the six screws (Y) on the sealing cover. See **Figure 39**.  
**Caution: Do not allow the sealing cover to hang from the ribbon cable. Doing so can damage the ribbon cable or its connectors.** Carefully remove the sealing cover and disconnect the ribbon cable. Save the screws and cover for reassembly.

Figure 38



Figure 39

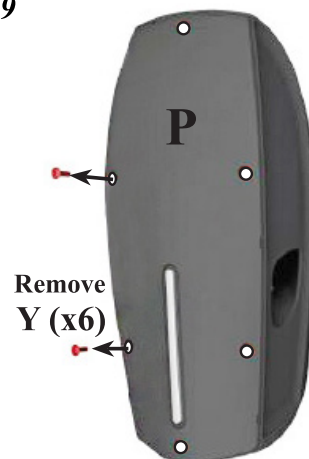



## TESLA® EVSE INSTALLATION (continued)

### 5. CONNECT THE WIRING

- a. The ground conductor and ground lug connections inside the Pedestal Post must be completed at this time. The ground lugs have a  $\frac{3}{16}$ " Hex screw (Allen screw) and are already installed inside the Top Panel (C) as shown in **Figure 40**.

**NOTE: The top access hole may be blocked on upcoming steps.**

- b. Pull the Service wiring through the Service Bushing (M) as shown in **Figure 41**.
- c. If Load Sharing will be utilized, pull the Signal wiring through the small bushing (N).
- d. Follow the TESLA® EVSE Installation Manual to complete the Wire Connections. **NOTE: The meaning of wiring colors might vary from country to country. Follow all applicable national and local regulations concerning wiring color codes.**

6. **WARNING! SILICONE MUST BE USED TO COMPLETELY SEAL THE TESLA TOP ENTRY BRACKET (Q) FROM THE PMD-10 TOP PANEL (C) AS SHOWN IN FIGURE 41.**

Figure 40

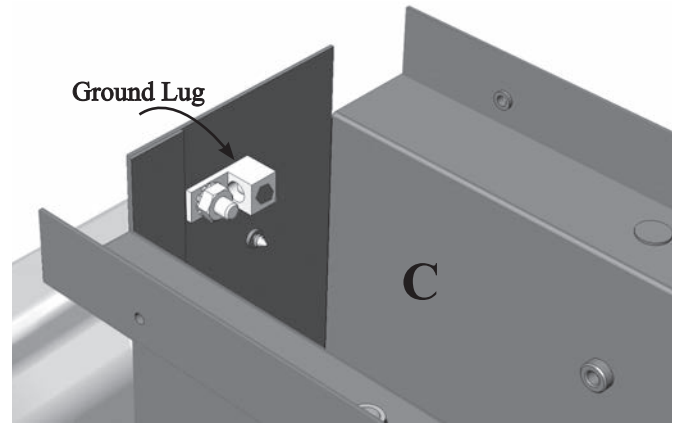
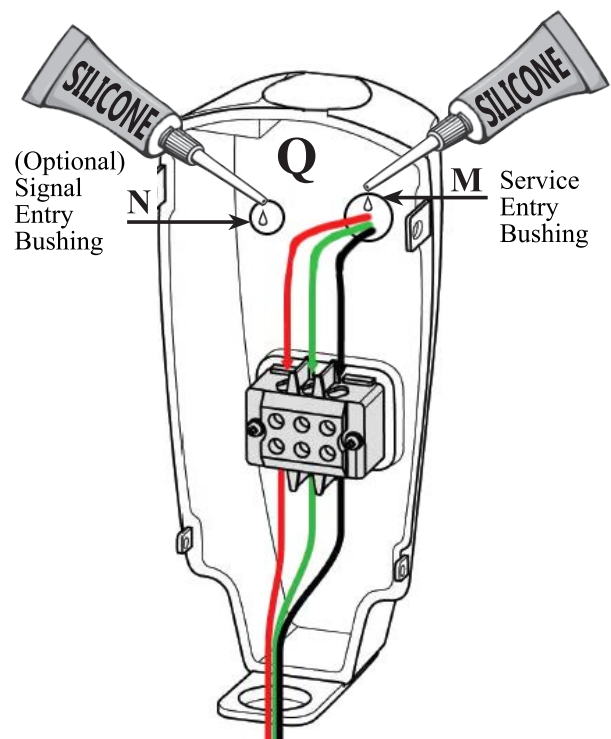

Figure 41





## TESLA® EVSE INSTALLATION (continued)

### 7. SECURE THE TESLA® EVSE (P) TO THE TOP ENTRY BRACKET

- Use a T20 Torx driver with the Top and Bottom Bracket-to-Housing Screws (W) & (X) to mount the TESLA® EVSE as shown in **Figure 42**.
- Push the Top and Bottom Bracket-to-Housing screw covers (U) & (V) into place. Note that each cover is unique and countoured to match the EVSE curvature. Push each cover into place after checking the contour match. Shown in **Figure 42**.
- Reconnect the ribbon cable to the sealing cover, then use a T20 security pin Torx driver to reinstall the six sealing cover screws (Y). Ensure that the cover is properly aligned before fully tightening the screws. See **Figure 43**.
- Screw in the Bottom Entry Conduit Plug (R) as shown in **Figure 44**. **NOTE: There should not be any visible openings to the inside of the Wall Connector, and the Wall Connector should be completely sealed from the environment.**
- Attach the outer cover to the sealing cover starting with the latch at the top. Engage the snaps on the sides and align the mounting tab with the housing at the bottom.
- Use a T10 Torx driver to reinstall the screw (Z) that secures the bottom of the outer cover to the TESLA® EVSE housing as shown in **Figure 44**.
- Loosely wrap the cable around the TESLA® EVSE.
- Stow the TESLA® connector in the TESLA® EVSE housing bracket.

Figure 42

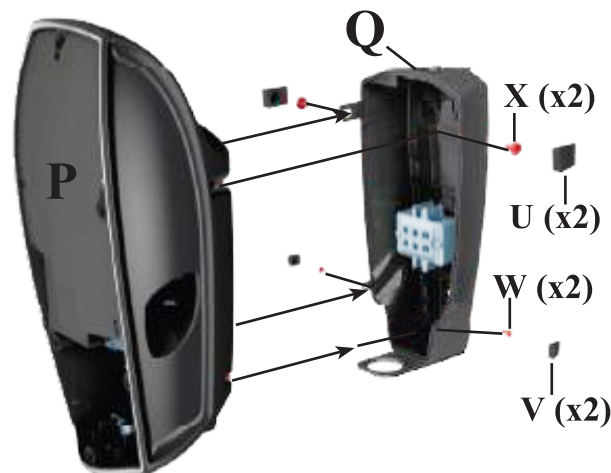

Figure 43

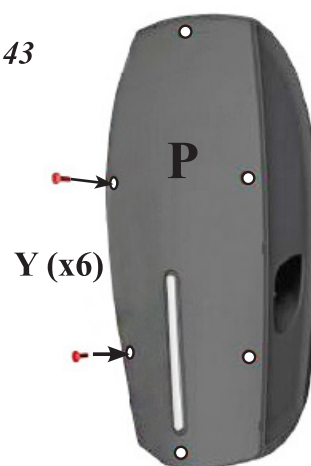

Figure 44



### 8. CHECK CONFIGURATIONS

- If a Single-Mount TESLA® EVSE Configuration is desired, please proceed to the Final Pedestal Installation section.
- If a Dual-Mount TESLA® EVSE Configuration is desired, repeat the TESLA® EVSE Installation section on the opposite side of the pedestal.
- If a HCS EVSE will be placed on the opposite side, refer to the HCS EVSE Installation section.
- If a LCS/ACS EVSE will be placed on the opposite side, refer to the LCS/ACS EVSE section.

INSTALLATION OF THE TESLA® WALL CONNECTOR EVSE IS NOW COMPLETE. PLEASE REFER TO THE TESLA® WALL CONNECTOR EVSE INSTALLATION GUIDE FOR TROUBLE-SHOOTING AND ADDITIONAL INFORMATION.



## FINAL PEDESTAL INSTALLATION

### 1. FOR SINGLE MOUNT PEDESTAL

- a. If a single mount configuration is desired, plug the remaining open screw holes on the opposite side of the pedestal using the remaining two (2) ¼-20 x 2" Torx T30 screw and washer sets (F) & (H), the (2) ¼-20 x ¾" Torx T30 screw and washer sets (G) & (H) and the four (4) #10 Torx T25 screw and washer sets (E) & (I) as shown in **Figure 45**.
- b. Verify that the black plastic caps (K) & (L) are firmly placed in and seated against the metal.

### 2. INSTALL THE TOP CAP (D)

- a. Carefully fit the Cap (D) over the Top Panels (C) of the Pedestal. The Top Panels will slide up into the Cap so that they are fully enclosed within the Cap. This is a tight fit. Keep fingers clear of pinch points.
- b. Push the Cap down until it is firmly seated on top of both Top Panels and can no longer move.
- c. Verify that the Cap's four obround screw slots are on the outside of both Top Panels and aligned with the corresponding screw holes.
- d. Secure the Cap to the Top Panels using four (4) #10 Torx T25 screw and washer sets (E) & (I). Do not over-tighten. See **Figure 46**.

### 3. VERIFY THE EVSE OPERATION

- a. Verify the safety of the installation prior to turning on the circuit breaker.
- b. Refer to the applicable ClipperCreek EVSE and/or TESLA® EVSE User's Guides for further operational and maintenance information.
- c. OPTIONAL: After turning on power supply, use the ClipperCreek CP-15 EVSE Tester to confirm correct operation (applicable to ClipperCreek EVSE only).

Figure 45

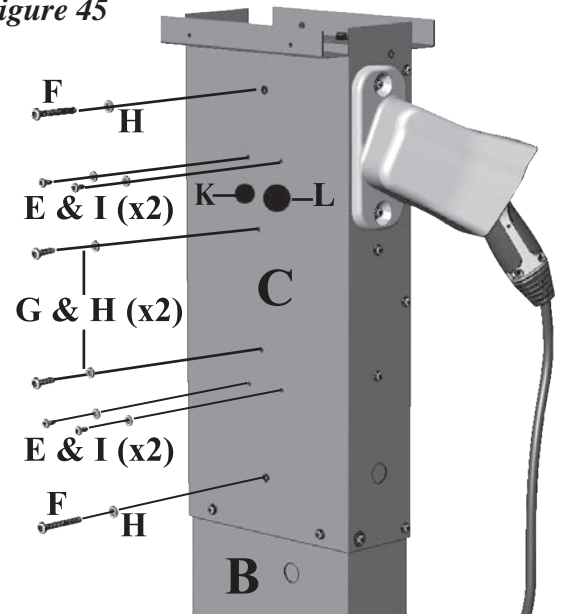
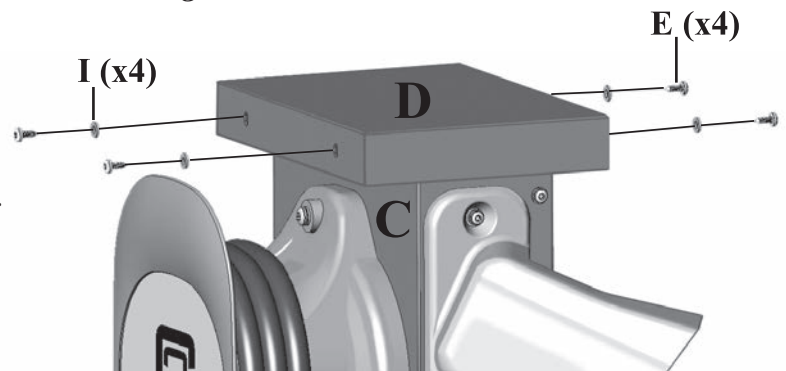

Figure 46



THE FINAL PEDESTAL INSTALLATION OF THE PROMOUNT DUO™ (PMD-10) IS NOW COMPLETE.



## CUSTOMER SUPPORT

Call your ClipperCreek, Inc. Service Representative at any time, 24 hours a day, at the number below.

**PLEASE HAVE THE MODEL NUMBER AND SERIAL NUMBER AVAILABLE WHEN YOU CALL.**

This information is printed on the label on the side of the pedestal. If calling after business hours or on weekends, please leave your name, telephone number, the unit serial number, and a brief description of the problem. A Service Representative will call back at the earliest opportunity.

**Distributor Service  
Number Here**

**TO CONTACT CLIPPERCREEK, INC. DIRECTLY FOR SERVICE, CALL (877) 694-4194 MONDAY TO FRIDAY BETWEEN 8:00 AM AND 5:00 PM PACIFIC STANDARD TIME.**



## **WARRANTY INFORMATION**

### **LIMITED WARRANTY ELECTRIC VEHICLE SUPPLY EQUIPMENT and ACCESSORIES**

ClipperCreek, Inc.  
11850 Kemper Road  
Auburn, California 95603  
Phone: 877-694-4194  
Email: [information@clippercreek.net](mailto:information@clippercreek.net)

ClipperCreek shall provide the following warranty with respect to the Products to Representative, its Sub-Representatives and their customers:

#### **Product 1-year parts, 1-year factory labor:**

ClipperCreek, Inc. warrants this product to be free from defects in material and workmanship. The warranty period shall commence on the date of installation date (first use). The product installation date must be evidenced and communicated to ClipperCreek by way of the warranty registration card (or its equivalent). The warranty registration card must be filled out completely and accurately, and returned to ClipperCreek within 30 days after installation, and the product installation date shall be within 6 months after the purchase date. If a product installation date is not communicated to ClipperCreek as described above, the product purchase date shall serve as the warranty commencement date.

If this product is defective in materials or workmanship during the warranty period, ClipperCreek will, at its option, repair or replace the product. Repair parts and/or replacement products may be either new or reconditioned at ClipperCreek's discretion. This limited warranty does not cover service or parts to repair damage due to improper installation or use, including but not limited to improper connections with peripherals, external electrical faults, accident, disaster, misuse, abuse or modifications to the product not approved in writing by ClipperCreek. Any service repair outside the scope of this limited warranty shall be at applicable rates and terms then in effect. This warranty covers factory parts and factory labor only; it does not cover field service or removal and replacement of the product or any other costs.

All other express and implied warranties for this product including the warranties of merchantability and fitness for a particular purpose are hereby disclaimed. Some states do not allow the exclusion of implied warranties or limitations on how long an implied warranty lasts, so the above limitation may not apply to you. If this product is not as warranted above, your sole and exclusive remedy shall be repair or replacement as provided above. In no event will ClipperCreek, any of its authorized sales and service representatives, or its parent company be liable to customer or any third party for any damages in excess of the purchase price of the product. This limitation applies to damages of any kind including any direct or indirect damages, lost profits, lost saving or other special, incidental, exemplary or consequential damages whether for breach of contract, tort or otherwise or whether arising out of the use of or inability to use the product, even if ClipperCreek or an authorized ClipperCreek representative or dealer has been advised of the possibility of such damages or of any claim by any other party. Some states do not allow the exclusion or limitation of incidental damages for some products, so the above limitation or exclusion may not apply to you. This warranty gives you specific legal rights, and you may also have other rights which may vary from state to state.

#### **To obtain warranty service:**

Call your nearest authorized Service Representative or ClipperCreek at the above number. You will receive information as to how service for the product will be provided. If you mail or ship the product in for service, you must insure the product, prepay all shipping charges, and properly pack it for shipment in its original shipping container or its equivalent. You are responsible for all loss or damage that may occur in transit. You must provide proof of purchase of the product and the purchase date before any warranty service can be performed.



**This page was intentionally left blank.**



**CLIPPERCREEK, INC.**

11850 KEMPER RD., SUITE E  
AUBURN, CA 95603  
WWW.CLIPPERCREEK.COM  
877-694-4194