



Kenneth M. Rubin
Senior Counsel
Florida Power & Light Company
700 Universe Boulevard
Juno Beach, FL 33408-0420
(561) 691-2512
(561) 691-7135 (Facsimile)
Ken.Rubin@fpl.com

April 23, 2018

-VIA ELECTRONIC FILING-

Ms. Carlotta S. Stauffer
Commission Clerk
Florida Public Service Commission
2540 Shumard Oak Blvd.
Tallahassee, FL 32399-0850

RE: Docket No.: 20170215-EU

In re: Review of electric utility hurricane preparedness and restoration actions.

Dear Ms. Stauffer:

Enclosed please find Florida Power & Light Company's Amended Response to Staff's Second Data Request (No. 2) in the above referenced docket.

If you should have any questions regarding this transmittal, please contact me at (561) 691-2512.

Sincerely,

/s/ Kenneth M. Rubin
Kenneth M. Rubin
Fla. Bar No. 349038

Enclosure
Cc: Counsel of Record

QUESTION:

For Hurricanes Hermine, Matthew, Irma, Maria, and Nate, please provide a complete copy of the utility's post-storm forensic review of damaged infrastructure. If a forensic review was not performed or not documented, please explain why.

AMENDED RESPONSE:

Post-storm forensics reviews are conducted based on the level of damage to infrastructure and the ability to deploy forensics teams to review the nature of the damage before restoration is completed.

During 2016, FPL collected data and performed analyses on Hurricanes Hermine and Matthew. FPL has previously provided Attachment Nos. 1 for the report on Hurricane Hermine - distribution only and Attachment No. 2 for the report on Hurricane Matthew - distribution and transmission/substation.

The post-storm forensics review report for Hurricane Irma has been completed and is attached to this amended response as Attachment No. 3.

No forensics reviews were completed for Hurricanes Maria (did not impact FPL) and Nate (limited impact/service restored within one day).



Power Delivery Performance

Hurricane Irma

Storm Date: September 9, 2017

Report Date: April 19, 2018

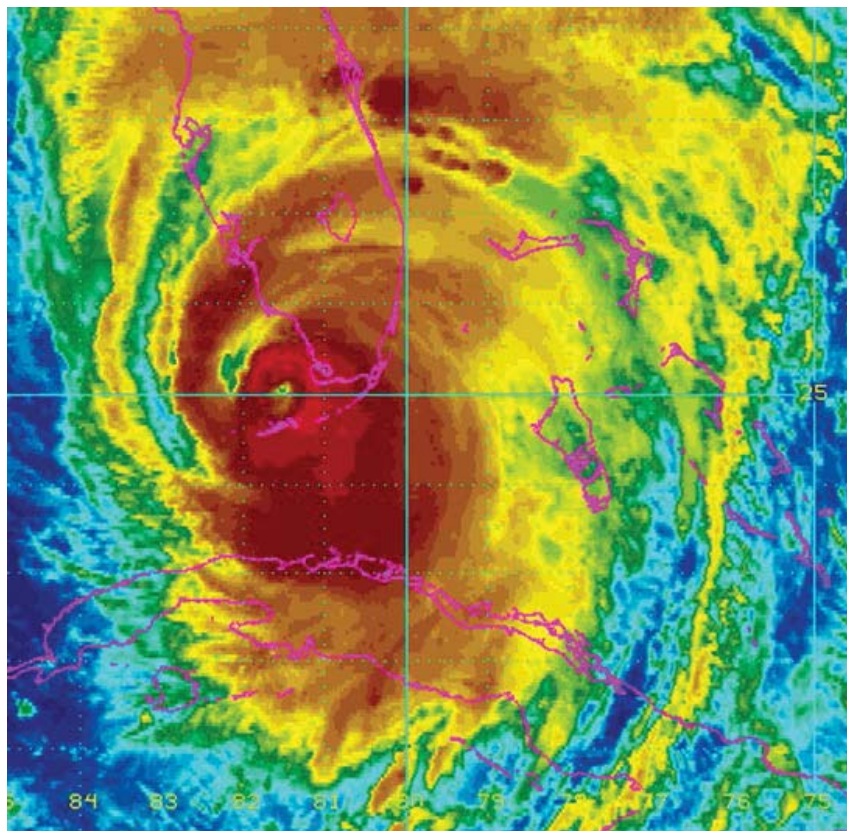



Table of Contents

1. General	5
Executive Summary	6
Hurricane Irma Quick Stats.....	8
Storm Characteristics and Weather	10
Actual Storm Path	10
Storm Surge	11
Tornadoes	14
Water Vapor	15
Rainfall	16
Vegetation Impacts	19
Pre-Landfall Storm Path	20
2. Transmission and Substation	25
Summary	25
Transmission Line Performance	26
Case Study: 5 Transmission Poles Down – All Wood.....	27
Substation Performance	28
Replacement by Type.....	29
Replacement by Area.....	30
Protective Relay Performance.....	31
De-Energized Distribution Substations	32
Case Study: De-Energized Substation Battery Voltage Monitoring	33
Case Study: Insulation Contamination at St. Lucie	34
Specific Event during the Storm – Hutchinson Island.....	36
Substation Flooding	37
Case Study: St Augustine Flooding	39
Case Study: South Daytona Flooding	42
Case Study: Pine Ridge Flooding	44
Case Study: Corkscrew Flooding.....	46
Case Study: Substation Fence and Gate Damage	47



Case Study: Belle Meade LCEC Shed Damaged Substation Equipment	49
Distribution Substation Transformers Experiencing Through Fault Levels	52
Damaging Effects of Faults.....	53
Case Study: Analysis of Failed Transformers	54
3. Distribution	55
Performance.....	55
Pole Performance.....	57
Case Study: Terry – Side Guying Failed Causing Leaning Poles	62
Case Study: Capri Leaning and Down Poles Due to Trailer Park Debris.....	63
Feeder Performance.....	68
Feeder Performance by Feeder Type	68
Hardened Feeder vs non-Hardened Feeder Performance	69
Case Study: Hardened vs non-Hardened Poles within a mile	72
Underground Feeder Performance	75
Lateral Performance.....	76
Distribution Transformer Performance	77
Pad-Mounted Switch Performance	80
Case Study: Miami Network Storm Surge.....	81
4. Smart Grid.....	86
AFS (Automated Feeder Switch) Performance	86
ALS (Automated Lateral Switch) Performance	88
5. Vegetation.....	89
Overview	89
Tree Characteristics	90
Patrol Observations and Analysis	91
Vegetation Trimming Guidelines	96
Case Study: High Density Foliage areas in South Florida “Rear-of-Service”	97
Case Study: Coral Gables	98
Case Study: West Florida.....	99



6. Restoration and Storm Comparisons.....	100
FPL Restoration Milestones.....	100
Restoration and Outages by County (All Utilities)	101
FPL Restoration Hurricane Wilma vs. Irma	102
Distribution Storm Comparison (Last 6 Largest Storms)	104
7. Other	105
Forensic Approach	106
Hardening Programs (Feeder and PIP)	110
Definitions / Acronyms	111



General

This is the Power Delivery Performance Report for Hurricane Irma. The purpose of this report is to give an overview of the performance and generalized assessment of the system with specific case studies describing conditions, damage, and system performance.





Executive Summary

On Sunday September 10, 2017, Hurricane Irma made two landfalls in Florida; once in the Keys as a Category 4 hurricane and the second time in Southwest Florida on Marco Island in Collier County as a Category 3 hurricane. Hurricane Irma also generated 21 confirmed tornadoes in the Florida Peninsula. Irma impacted all 35 counties across the 27,000 square miles of FPL's service territory causing outages for 4.4 million or 90% of FPL customers. Hurricane Irma was an unprecedented storm by almost every measure -- size, destructive power and slow movement. The powerful storm spawned tornadoes, uprooted large trees, transformed roads into rivers, flooded isolated areas, and tore roofs off homes and businesses.

The investments in the FPL Grid since 2006 have made it more storm resilient. During Hurricane Irma, Transmission and Distribution Hardening and Smart Grid worked together to reduce the severity, amount of damage, and improve situational awareness.

The results: 50% of Customers restored in one day, 75% in three days, 95% in seven days and 100% in ten days. Average customer outage was 2.1 days for Irma compared to 5.4 days for Wilma

FPL Transmission System performed well in Irma. It is a testament to the benefits of hardening improvements that only 5 poles failed (1 wood pole on the Bulk Electric System and 4 wood poles on a 69KV circuit.) West Area, where the storm made landfall, has no transmission wood structures and had 0 pole failures. 127 Transmission lines tripped and 92 Substations went out. Substations were back in service in one day compared to 5 days in Wilma. 86 of the 92 Substations were out due to transmission outages, 4 for equipment damage and 2 were proactively deenergized due to flooding. Protective relay systems and Breakers were called on to clear 150 short circuit events and had only 2 mis-operations (1.3%). This is well below the 8% NERC average.

FPL Distribution System performed well in Irma and demonstrated that the investments in the Distribution Feeder Hardening Program, Pole Inspection Program (PIP) and Smart Grid are providing benefits. The system performed as designed and greatly helped to reduce severe damage, duration of restoration and provide the ability for the grid to self- heal. These investments were key to the speed of storm restoration.

Distribution Pole Damage was primarily due to fallen trees. 40% of total pole damage was in the west area where the storm made landfall and the ground was already saturated by severe rainfall before the storm. Southwest Florida had received record rainfall (16") less than 2 weeks before Irma which contributed to trees uprooting and poles leaning. Dade area had 30% of total pole damage which was primarily due to fallen non-native trees that are less storm resilient. Also, some areas in Dade choose to not follow the right tree, right place program which resulted in trees falling into poles and lines.

Hardened Feeder design philosophy to reduce restoration times by minimizing the number of pole failures during extreme wind and weather events was tested in Irma. During Irma, Hardened Feeders poles performed 10X better, required 50% less work to restore and had significantly fewer outages compared to non-Hardened Feeders demonstrating the benefits of hardening.



Non-Hardened Feeder performance and restoration benefitted from the Pole Inspection Program (PIP) which has resulted in the replacement of over 80,000 poles and reinforcement of over nearly 50,000 poles since the inspection program began in 2006.

Overhead Lateral outage rate was 4.7X greater than the Overhead Feeders outage rate with a failure every 1.2 miles of Overhead Lateral compared to every 5 miles of Overhead Feeders. Restoration of these Laterals is generally more difficult as many are in the rear of our customer's residential properties. That said, 24% of Overhead Laterals had damage that caused an outage. Underground Laterals performed 6.6X better than Overhead Laterals. Lateral Undergrounding part of the system, to alleviate restoration challenges related to significant access and vegetation issues, should be considered as a next step for grid hardening.

Smart Grid provided benefits that did not exist in 2004-2005 storm season. 546,000 Customer interruptions were prevented by self-healing of the grid during the storm.



Hurricane Irma approaching Cuba and the Florida Peninsula.



Hurricane Irma Quick Stats

Meteorology

- Landfall in the Florida Keys as a CAT 4 Sunday 9:10 AM, September 10, 2017
- Second landfall in Marco Island as a CAT 3 at 3:35 PM, September 10, 2017
- Maximum sustained winds of 130 mph in Naples area, gusts to Hurricane strength throughout the east coast
- 21 tornadoes confirmed in the Florida Peninsula
- Rainfall of up to 21.66 inches, which was 3 to 5 times more than Wilma
- Southwest Florida was saturated and had flooding only a couple of weeks before Irma
- Widespread flooding in various areas throughout the state
- The path around the peninsula and relatively slow forward speed caused tropical storm force wind durations near 24 hours over parts of the FPL territory
- 4.3 Cyclone Damage Potential Index is higher than Wilma (2.6) and higher than any hurricane since Andrew

Vegetation

West area saturated with record breaking rainfall two weeks before Irma made landfall plus Irma impact led to significantly higher tree uprooting. Dade and East areas have a higher % of non-native trees that are less storm resilient

- **Tree Failure causes**
 - Up-rooting /Broken Trunks 57%
 - Broken Limbs 43%

- **Tree Damage**

	Native	Non-Native
○ Dade	20%	80%
○ East	30%	70%
○ West	55%	45%
○ North	70%	30%

Distribution System Performance

- **Feeders Out** **2,286** **170K CMH**
 - UG 85
 - Hardened 592
 - Non-Hardened 1,609

Excludes outages caused by Transmission and Substation

- **Laterals Out** **24,108** **871K CMH**
 - OH 20,341
 - UG 3,767
 - Underground performed 6.6X better than Overhead

Excludes outages caused by Feeder, Transmission and Substation



- **Overhead Feeder To Lateral Comparison:**
 - **Overhead Feeders performed 4.7X better than Overhead Laterals.**
 - OH Feeders had an outage every 5 miles while OH Laterals had an outage every 1.2 miles
 - **OH Feeders required 1 hour CMH to an average of 5 hours CMH for OH Laterals.** The total CMH estimate for Irma is 170K CMH for Overhead Feeders and 871K for Overhead Laterals
- **Distribution Transformers**
Single phase pad mount transformers for Underground Systems performed 3.5X better than aerial transformers for Overhead systems. This further hi-lites the difference of Underground Systems vs. Overhead in a major storm.
- **Poles Down ***

	2860	(Feeder, Lateral, Service, Telephone)
○ Hardened Feeder	26	(0.02%)
○ Non-Hardened Feeder, Lateral, Service, Telephone	2,834	(0.20%)

* Poles replaced to restore power
- **Smart Grid**
Automatic Feeders Switch (AFS) teams operated to avoid 546,000 Customer Interruptions

Hardened Feeder Performance

Hardened Feeders demonstrated significantly better performance. The primary objective of hardening is to reduce restoration times by minimizing the number of pole failures during extreme wind weather events.

- **Hardened Feeders performed better than non-Hardened Feeders**
 - Pole Failure Rate 10x better
 - CMH to Restore 2x better
 - Outages 1.19x better

Transmission and Substation System Performance

- **Transmission Out 215 line sections**
- **Transmission Poles Down 5**
 - BES (Bulk Electric System) 1 (wood, non-hardened)
 - Non-BES (69kV) 4 (wood, non-hardened)
- **Substations Out 92**
 - Transmission outages 86
 - Substation Equipment 4
 - Flooded 2 (proactively deenergized)

Other

- Injuries OSHA 9
- Injuries / 200,000 CMH 2.35
- Forensics Teams Deployed 42 personnel (trans., sub, dist.)



Storm Characteristics and Weather

Hurricane Irma began to directly affect South Florida early in the morning on September 9, 2017. As Hurricane Irma traveled north through the state, it continued to impact customers into the evening on September 11. Due to its size and path, Hurricane Irma impacted all 35 counties across FPL's 27,000 square-mile service territory. The National Hurricane Center's preliminary report estimates that parts of FPL's service area experienced hurricane-force winds as high as 142 miles per hour and rainfall totaling as much as 21.66 inches.

Hurricane Irma was an unprecedented storm by almost every measure -- size, destructive power and slow movement. The powerful storm spawned tornadoes, uprooted large trees, transformed roads into rivers, flooded isolated areas, and tore roofs off homes and businesses. FPL brought in twice as many tree trimming crews to support the Irma restoration effort compared with Hurricane Wilma in 2005.

Actual Storm Path

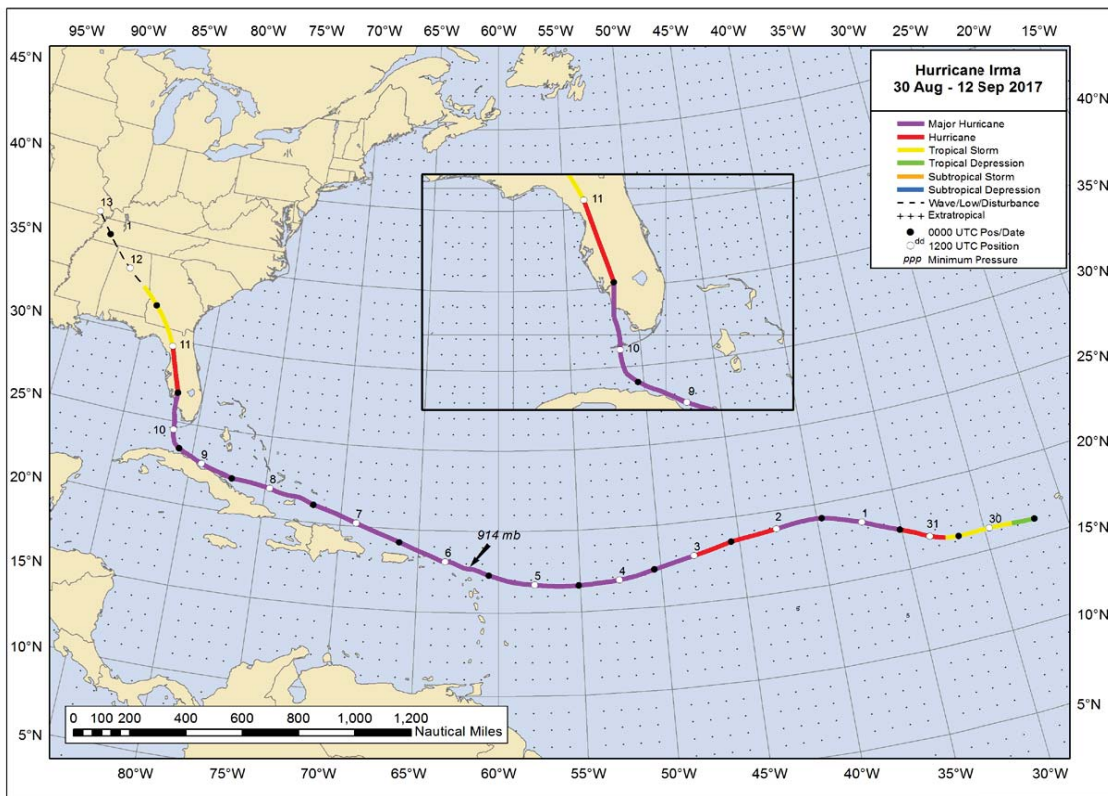

Best track positions for Hurricane Irma, 30 August–12 September 2017 (Source NHC)



Storm Surge

Examples of storm surge caused by Hurricane Irma across Florida.





Storm Surge Summaries (Source NHC)

COLLIER COUNTY: Highest inundation in Chokoloskee of 6-8 feet at waterfront, approximately 8 feet above mean higher high water (MHHW), with 3-5 feet across most of island. In Everglades City, maximum 6 feet of inundation at Everglades National Park Gulf Visitor Center, with 2-4 feet across the town and as high as 5 feet in a few areas. In Marco Island there was 2-4 feet inundation mainly on South and East parts of Island with less than half mile inland penetration. In Naples there was 3-4 feet inundation along Gulf water-front within 1 block of beach, with less than half mile inland penetration. Highest inundation values were noted in Vanderbilt Beach as well as South of Naples Pier. Along Naples Bay, inundation of 1-2 feet on West side of bay just South of Tamiami Trail, resulting in about 2-3 feet above MHHW. The National Ocean Service (NOS) tide gauge at Naples measured a water level of 4.25 feet MHHW. USGS storm tide sensors in Naples and at Delnor-Wiggins State Park near Naples Park measured water levels of 5.06 feet NAVD88 (4.5 feet MHHW) and 3.90 feet NAVD88 (3.4 feet MHHW), respectively.

LEE COUNTY: The gauge at Ft. Myers on the Caloosahatchee River recorded a water level of 3.28 feet MHHW. In Bonita Springs USGS Survey indicated surge of 4.64 feet. up the reaches of the Imperial River.

DESOTO COUNTY: Inundation of up to 6 feet along the Peace River near Arcadia from surge and rain.

DADE COUNTY: The combined effect of storm surge and the tide produced maximum inundation levels of 4 to 6 feet above ground level for portions of Miami-Dade County in southeastern Florida, especially along Biscayne Bay. A USGS storm tide sensor at Matheson Hammock Park in Miami measured a peak water level of 5.75 feet NAVD88 (5.6 feet MHHW), consistent with a high water mark of 5.1 feet above ground level which was surveyed in the park. The NOS tide gauge on Virginia Key recorded a peak water level of 3.7 feet MHHW. Lesser inundation occurred North of downtown Miami and along Atlantic oceanfront.

BROWARD COUNTY: 2-3 feet inundation along the barrier island from Ft. Lauderdale Beach South. Tidal overwash reported in Ft. Lauderdale on A1A and adjacent streets. Inland penetration was less than half a mile.

PALM BEACH to INDIAN RIVER COUNTIES: A storm tide sensor along the Intracoastal Waterway in Boca Raton recorded a wave-filtered water level of 3.05 feet NAVD88 (2.7 feet MHHW), and the NOS tide gauge at Lake Worth measured a peak water level of 1.5 feet MHHW. Farther north, maximum inundation levels of 1 to 3 feet above ground level occurred across coastal sections of Martin, St. Lucie, Indian River, and southern Brevard Counties.

BREVARD COUNTY: A maximum of 3 to 5 feet of inundation above ground level occurred from Cape Canaveral northward to the Florida-Georgia border. The NOS tide gauge on Trident Pier at Port Canaveral measured a peak water level of 4.2 feet MHHW.

VOLUSIA COUNTY: A USGS storm tide sensor at Ormand Beach recorded a water level of 4.37 feet NAVD88 (4.5 feet MHHW).



ST. JOHNS COUNTY: Durbin Creek reported a storm surge over 5 feet and 4.7 feet at Racy Creek. A storm tide sensor on the Matanzas River south of St. Augustine recorded a wave-filtered water level of 6.65 feet NAVD88 (4.8 feet MHHW), and the USGS surveyed several high water marks of 2 to 4 feet above ground level in that area. The highest was a mark of 3.3 feet above ground level near Vilano Beach.

DUVAL COUNTY: A storm surge of nearly 6 feet was recorded along the St. John's River and several surrounding rivers and creeks. Along the coast of extreme northeastern Florida, a storm tide sensor at Jacksonville Beach recorded a wave-filtered water level of 6.55 feet NAVD88 (4.1 feet MHHW).

NASSAU COUNTY: A storm surge up to 7.78 feet was recorded along Fernandina Beach. In addition, the NOS gauges at Mayport (Bar Pilots Dock) and Fernandina Beach both measured peak water levels of 3.6 feet MHHW.

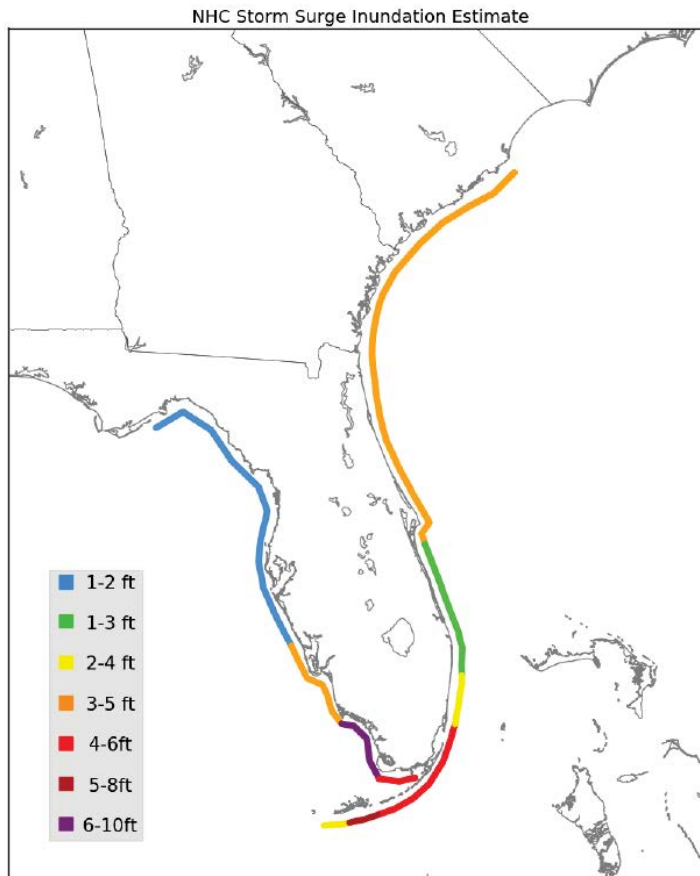

Analyzed storm surge inundation (feet above ground level) along the coasts of Florida, Georgia, and South Carolina from Hurricane Irma. Image courtesy of the NHC Storm Surge Unit.



Tornadoes

Twenty-one tornadoes were reported in the Florida Peninsula.

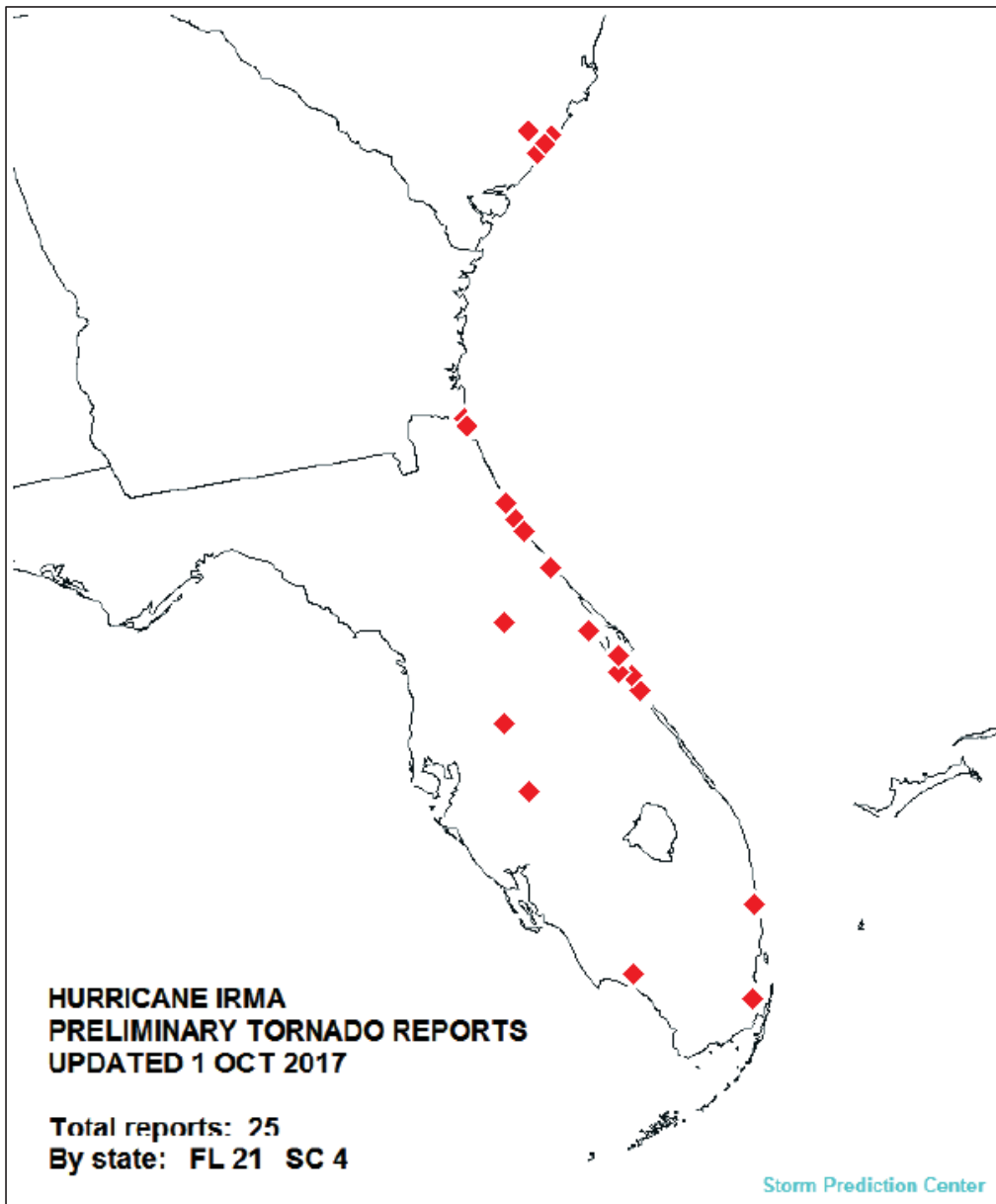

Map of tornado reports from Hurricane Irma. Courtesy of NOAA's Storm Prediction Center.



Water Vapor

Color water vapor images taken from NOAA's GOES Satellite* shows a dry slot coming across the St. Lucie Site (designated by star) after the eye had passed north of the plant which caused significant insulator contamination**. This was typical for several locations along the East coast.

* ftp://ftp.nnvl.noaa.gov/GOES/color_WV/

** Insulator Contamination Case Study on page 34

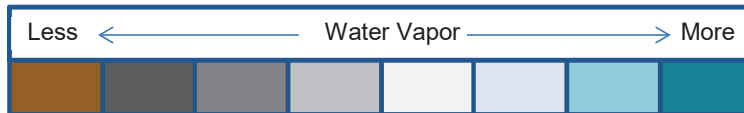

9/11/17 at 12:45AM

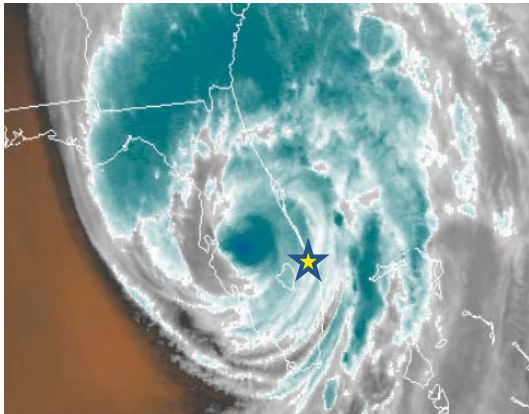

9/11/17 at 01:44AM

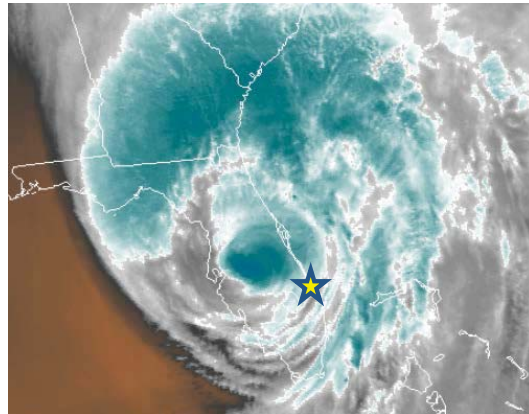

9/11/17 at 02:16AM

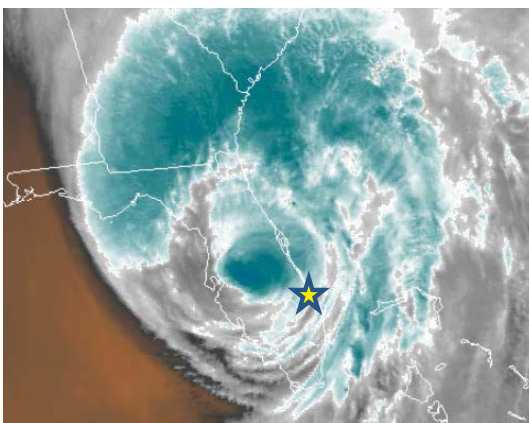

9/11/17 at 04:14AM

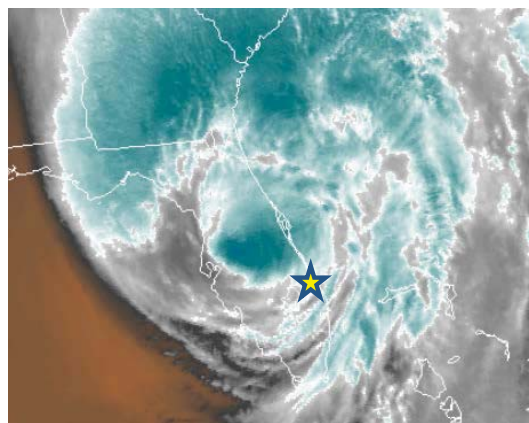



Rainfall

Rainfall Pre-Storm per SFWMD (South Florida Water Management District)

In general, more rain fell (~ 3") for the entire district from Irma (2017) as compared to Wilma (2005); however, in specific regions the rainfall was as much as 10" more from Irma as compared to Wilma. Also, note that the light blue sections designate that rainfall was 150%-200% above average. Significant wet soil conditions pre-storm combined with the slow moving Irma storm caused significantly more uprooting of vegetation.

County / Region	Irma	Wilma	Difference	Circle Color
Southwest Coast	46.10	35.25	10.85	Red
SW Palm Beach & NW Broward	33.58	23.48	10.10	Purple

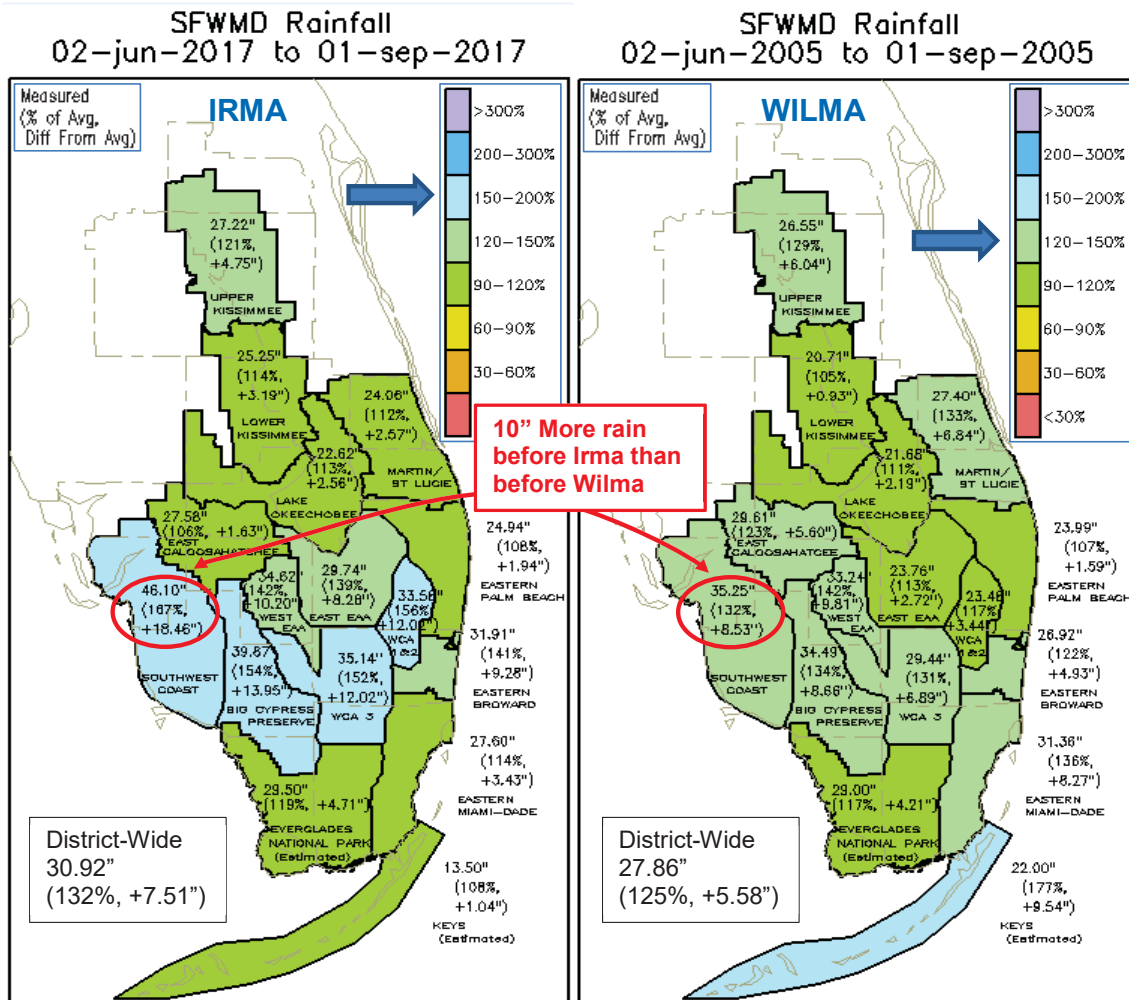



Rainfall Pre-Storm

- The three day period between Aug. 25 and Aug. 27 produced over 16 inches of rain in Southwest Florida which was well above the all-time record (9.8 inches.)



Picture of Southwest Florida on August 28, 2017 2 weeks before IRMA. Source: Kin fay Moroti/news-press.com

Rainfall 14 day Precipitation Centered on Storm Landfall

NWS Precipitation Analysis 4-km HRAP Grid -- 14-day Total Accumulation Domain Max: 20.0 in.
Total Precipitation [inches] 14 days 12Z03SEP2017 --> through --> 12Z17SEP2017

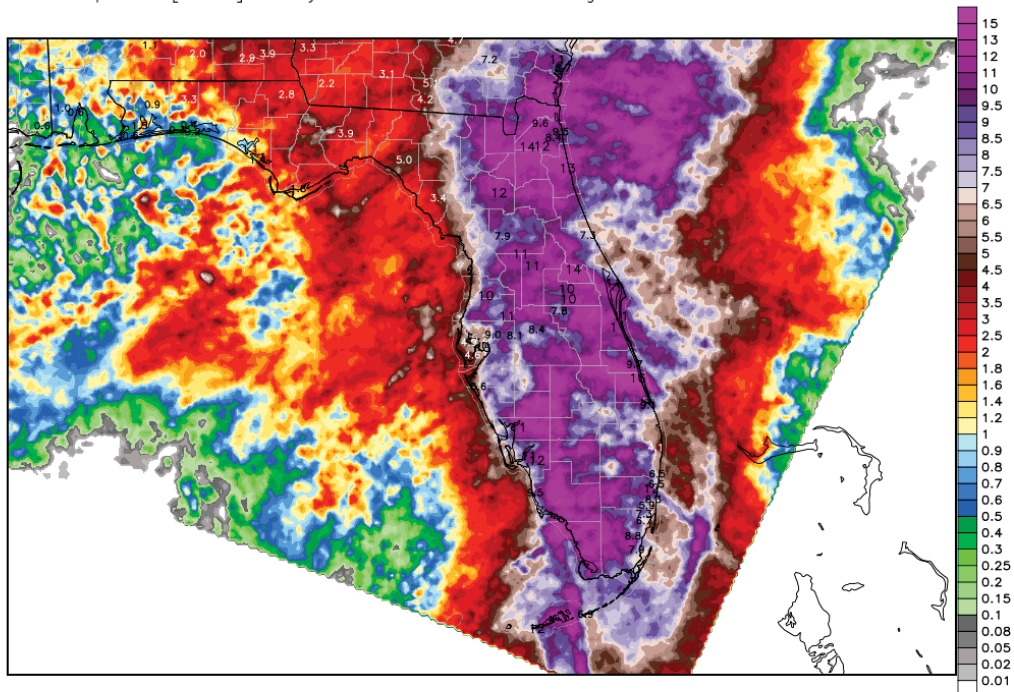

4 km HRAP grid | End of hydrological day at 1200 UTC | <http://water.weather.gov/precip>



Actual Storm Rainfall over a 3-Day Span

- Irma experienced 3 to 5 times more rain as compared to Wilma

Wilma Rainfall was 3-7 inches

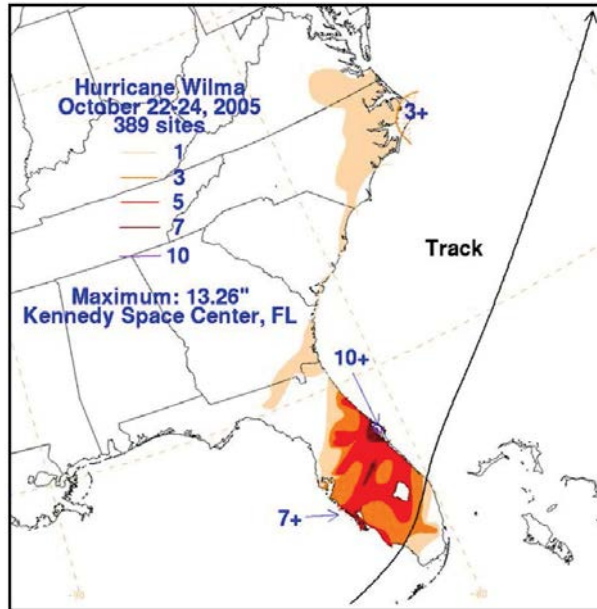

Hurricane Wilma storm total rainfall map (22-24 October 2005), constructed using data provided by NWS River Forecast Center courtesy of NOAA/NWS Hydrometeorological Prediction Center.

Irma Rainfall was 12-15 inches





Vegetation Impacts

- Vegetation section starting on page 89 with detailed analysis



Vegetation outside of ROW toppling into Overhead Circuits was common.



Pre-Landfall Storm Path

72 Hour Pre-Landfall

NHC 9/7/17 11:00am Advisory

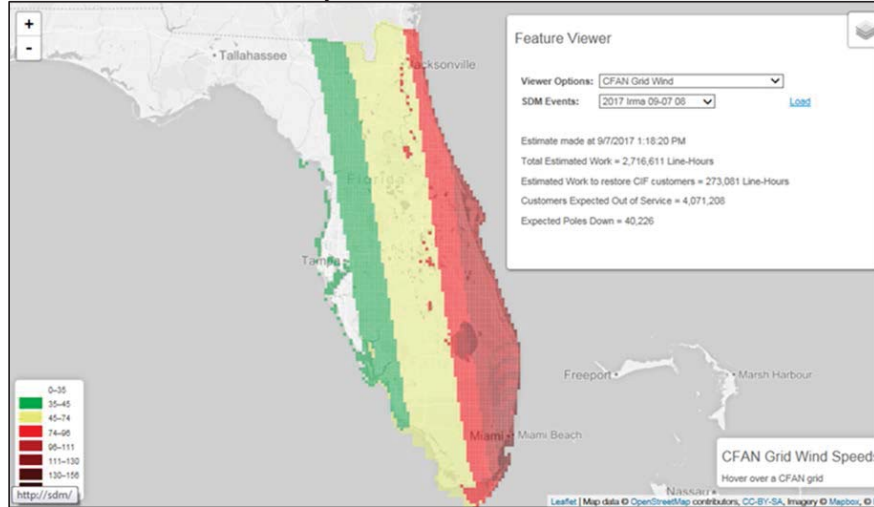

NHC Track 9/7/17 11:00am Advisory

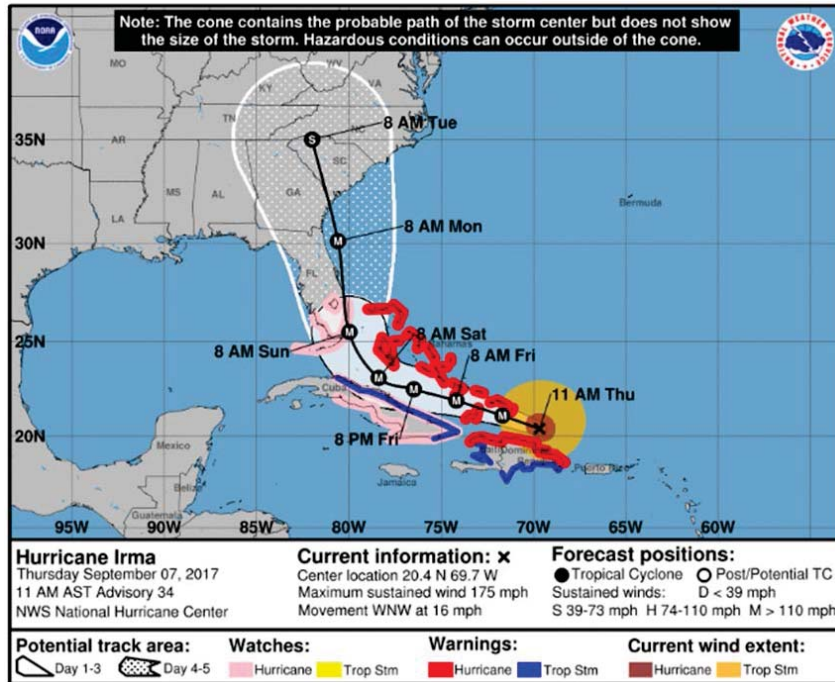



48 Hour Pre-Landfall

NHC 9/8/17 11:00am Advisory

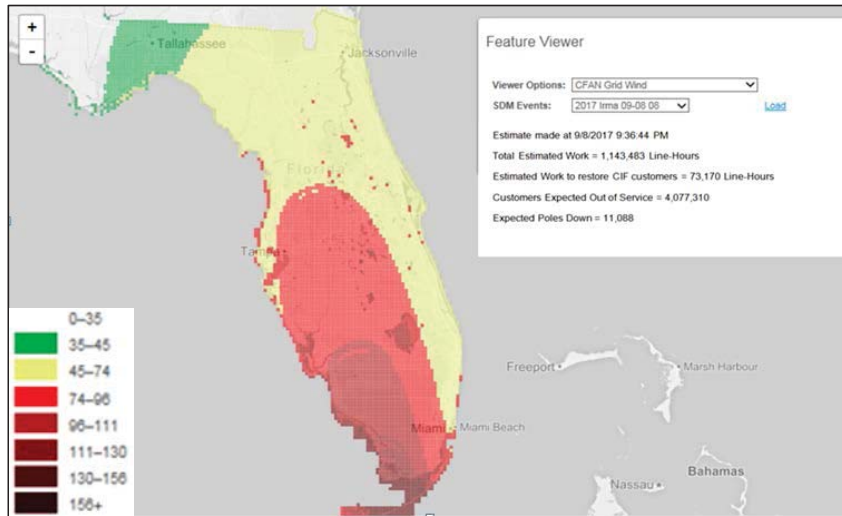

NHC Track 9/8/17 11:00am Advisory

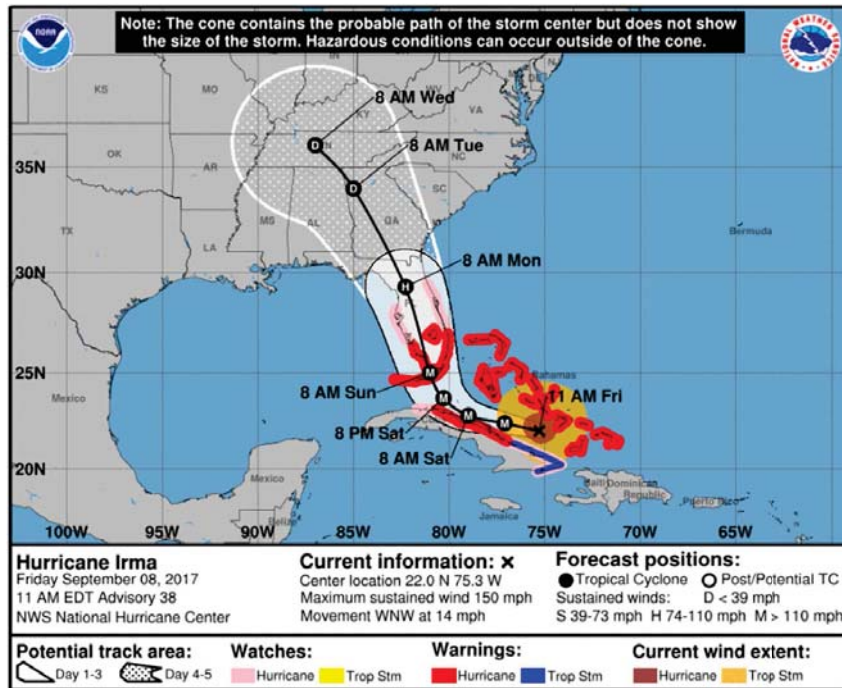



24 Hour Pre-Landfall

NHC 9/9/17 11:00am Advisory

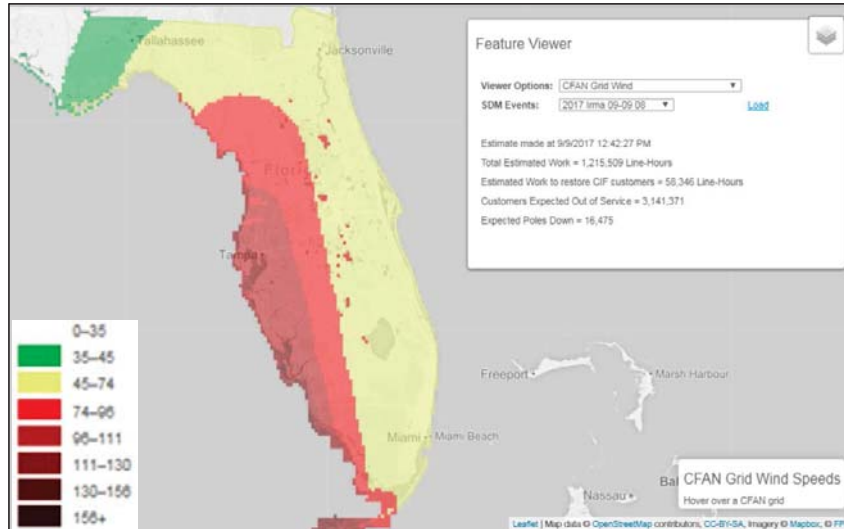

NHC Track 9/9/17 11:00am Advisory

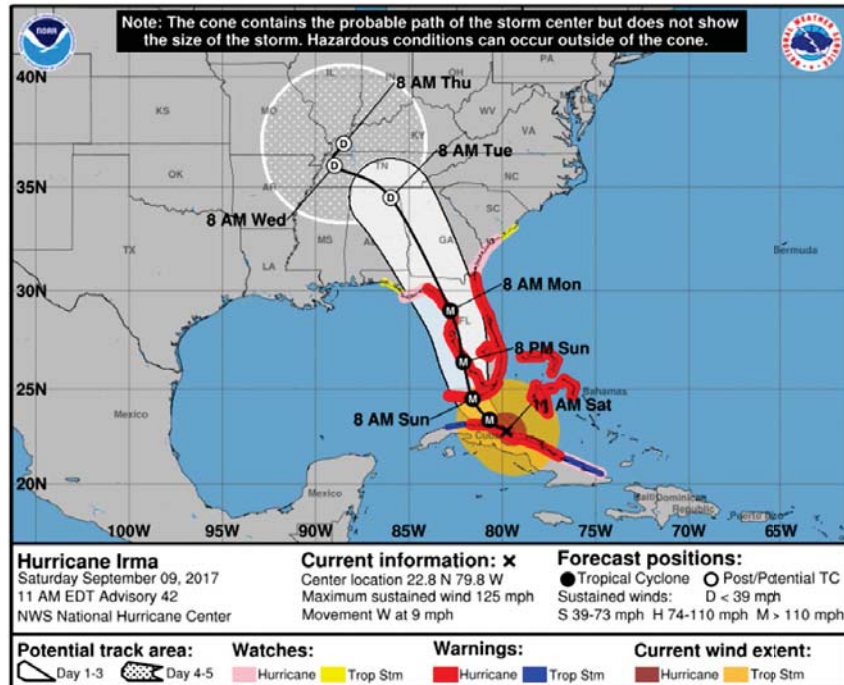



Final Hour Pre-Landfall

NHC 9/10/17 11:00am Advisory

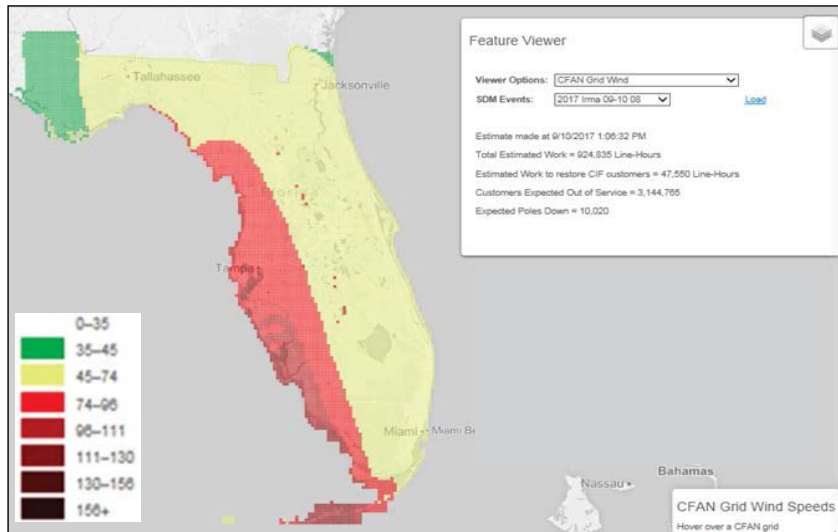

NHC Track 9/10/17 11:00am Advisory

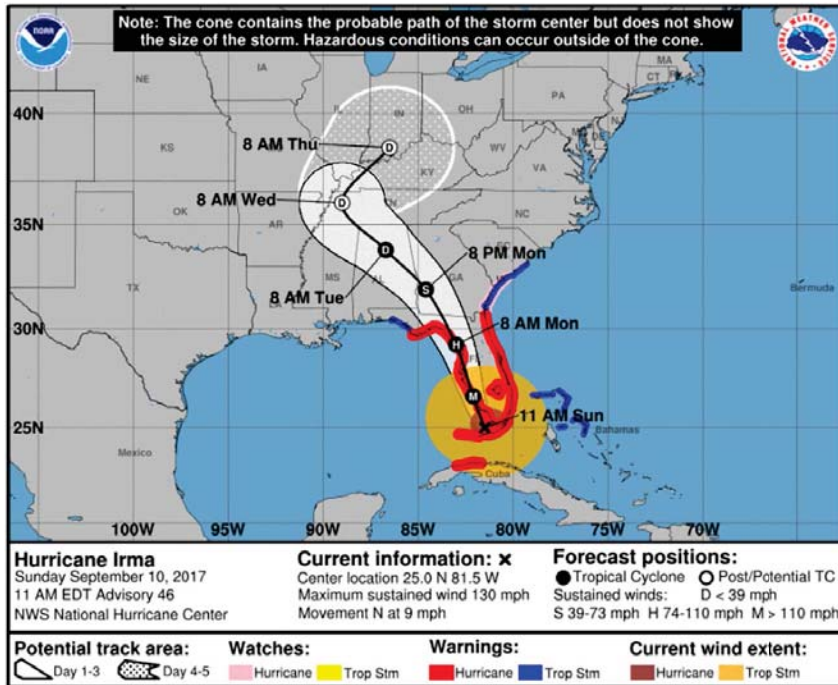



Actual Storm Path (Source: NHC)

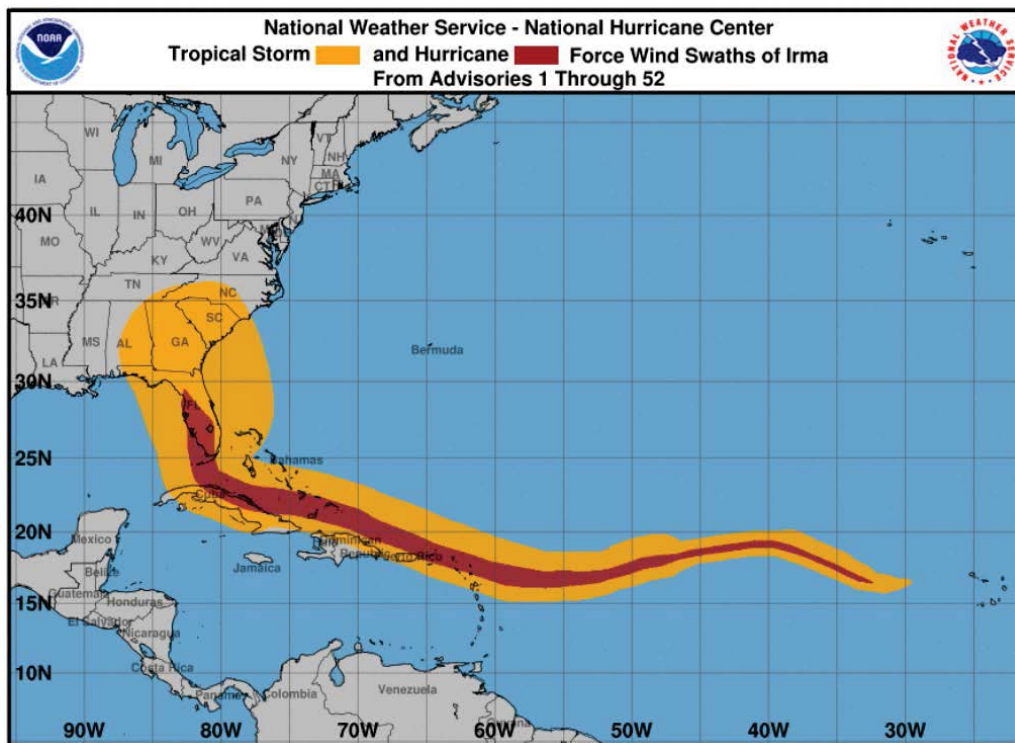
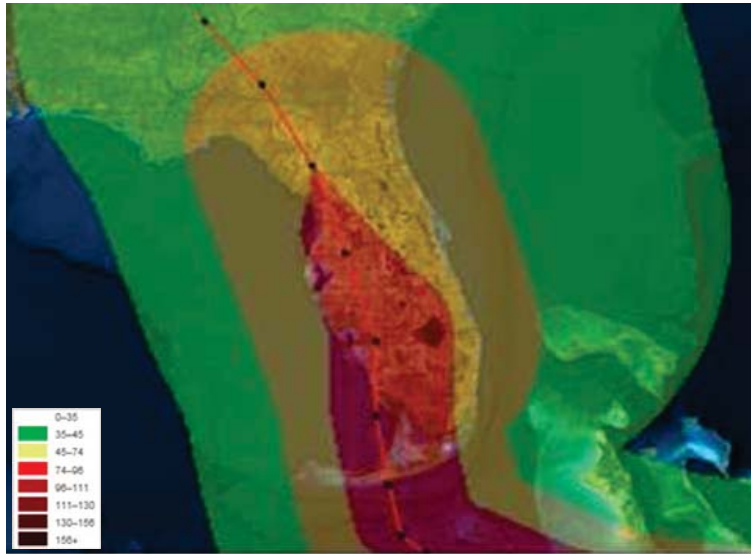



Transmission and Substation Performance

Summary

Overall, the Transmission System performed well during the storm event. Equipment and conductor damage was minimal. ***Duration of outages was approximately 1 day.***

Transmission lines out: 127

- Voltage class 7 -69kV, 26 -115kV, 58 -138kV, 35 -230kV, 1-500kV

Transmission line sections out: 215

- Voltage class 14 -69kV, 69 -115kV, 90-138kV, 41 -230kV, 1-500kV

Substations out: 92

- 86 due to transmission line outage
- 2 were de-energized proactively due to flooding (St. Augustine and South Daytona)
- 4 due to Substation equipment damage (Delta, Haulover, Lighthouse and Memorial)

Protection System Performance:

- There were 150 transmission relay events and 2 mis-operation for a 1.3% mis-operation rate (NERC goal is 8.0%, FPL 12 month average is 4.8%)
- Calculation based on NERC PRC-004

Major Equipment Damage:

Transmission Lines and Substations

- Replace 4 structures on Sweatt to Sweatt Tap line section on the Okeechobee to Sherman #1 69kV line
- Replace 1 structure on the Deland to Putnam 115kV line
- HV breakers 2 (1-230kV and 1- 138kV)
- Repair 5 cross braces

Distribution Substations

- Power Transformers 7
 - 1-230/23kV, 2-138/13.8kV, 4-138/13.8kV TCUL
- Medium Voltage (MV) Breakers 38
 - 34-13.8kV feeder, 3-23kV feeder, 1-13.8kV bus breaker
- Regulators 18
 - 11- 13.8kV, 7-23kV
- Surge Arrestors 20
 - HV Transformers 17 (4-230kV, 14-138kV)
 - Line Arrestors 3 (2-230kV, 1-138kV)
- Transformer Bushings 7 (replace in sets of 3):
 - HV- 2 (6 units 138kV)
 - LV -5 (15 units 13.8kV)
- Battery Bank -1
- Relay Roof – 1 (Basscreek)
- Flooded Substations – 2 (St Augustine and South Daytona)



Transmission Line Performance

Overall Transmission Performance was good during the storm event. Equipment and conductor damage was minimal. All lines were patrolled after the storm

Transmission System Performance

- 127 out of 523 Transmission lines experienced 150 Relay Operations
- 215 out of 1241 Line Sections out

Damage / Component Failures

- 5 poles down on 2 line sections
- 5 Cross braces repaired
- 28 structures with phases down
 - 27 due to trees
 - 1 due to insulator failure
- 3 OHGW failures
- 6 spans replaced

Causes

- Most of these outages were caused by vegetation and some by wind-blown debris
- Thirteen Underground line sections were isolated due to contamination at the substation line terminals
- 2 line sections de-energized to isolate St. Augustine substation due to flooding
- 2 line sections de-energized to isolate S. Daytona substation due to flooding



Structure 55R13A – Broken insulator



Structure 112R1 - Wire down due to vegetation



Case Study: 5 Transmission Poles Down – All Wood

Deland-Putnam 115kV - One Wood Transmission Structure

- One single pole wood structure (75G3) was replaced on the Deland-Putnam 115kV [0091] Line, Satsuma Tap-Putnam Tap Section.
 - The poles were inspected in 2017. The pole was reported as Level 4 condition (replacement not required).
- Winds in the area were reported to be 61-80 mph gusts or higher
- An approximately 80 foot tall slash pine tree was reported to have fallen on the transmission line; the impact caused this pole to fail.

Okeechobee-Sherman #1 69kV – Sweatt Tap - Four Wood Structures

Four Non-BES single pole wood structures with distribution underbuilt (73K13, 74K1, 76K8, and 81K8) were replaced on the Okeechobee-Sherman #1 69kV [0274] Line, John C. Eisinger Tap-Sweatt Tap 2 (Tap) Section.

- There were 3 separate failure locations
- All of the poles were inspected in June 2017 and 2 of the 4 poles were identified for replacement in 2018/2019
 - Structure 74K1 was identified for replacement bringing down an adjacent structure 73K13. Deterioration was noticed with 1" of shell remaining on structure 74K1 at groundline.
 - Structure 76K8 was identified for replacement came down alone.
 - Structure 81K8 was identified as a level 4 (replacement not required) from inspection.



Pole Replacement of Structure 75G3 (115KV line in North area)



Substation Performance

Overall Substation Performance was good during the storm event with all substations being partially energized by 9/12/2017 and fully energized on 9/13/2017 by 9:57AM on.

- 92 Distribution Substations out of 607 total Substations were out
 - 86 for due to Transmission outages
 - 2 were deenergized proactively for flooding (St. Augustine and South Daytona)
 - 4 for Substation Equipment issues (Delta, Haulover, Lighthouse and Memorial)
- 150 BES Relay Operations with two relay mis-operations (1.3 % mis-operations)
- Substation Communications lost
 - TELCO: 135 stations
 - Wireless: 11 stations
 - Both wired and wireless: 6 stations
- 98 locations of equipment damage
 - 60% of damage was failed surge arrestors and feeder breakers
- Two flooded substations that were proactively de-energized.
 - St. Augustine and South Daytona
 - The flood monitoring system and response process performed as expected and in a fashion to minimize damage and speed restoration.
- System protection operated as expected.
 - One breaker event was reported.
- Substation communications were lost at 135 stations and 11 stations lost wireless communications.
- 1 station experienced battery loss due to extended outage.
- No mobile equipment was deployed during this hurricane.

Post Storm Events

- A number of events continued to occur post storm. This included breakers, bushings, surge arresters and battery bank failures after initial energization.
- In addition, post storm failures were due to internal contamination presumably from wind-blown salt water and contamination given the orientation of the storm when it came on-shore.
- The North-East quadrant of the storm (aka the "dirty side") impacted most of the FPL territory contributing to the contamination damage.



Substation Equipment Performance “Replacement by Type” and “Failures by Root Cause”

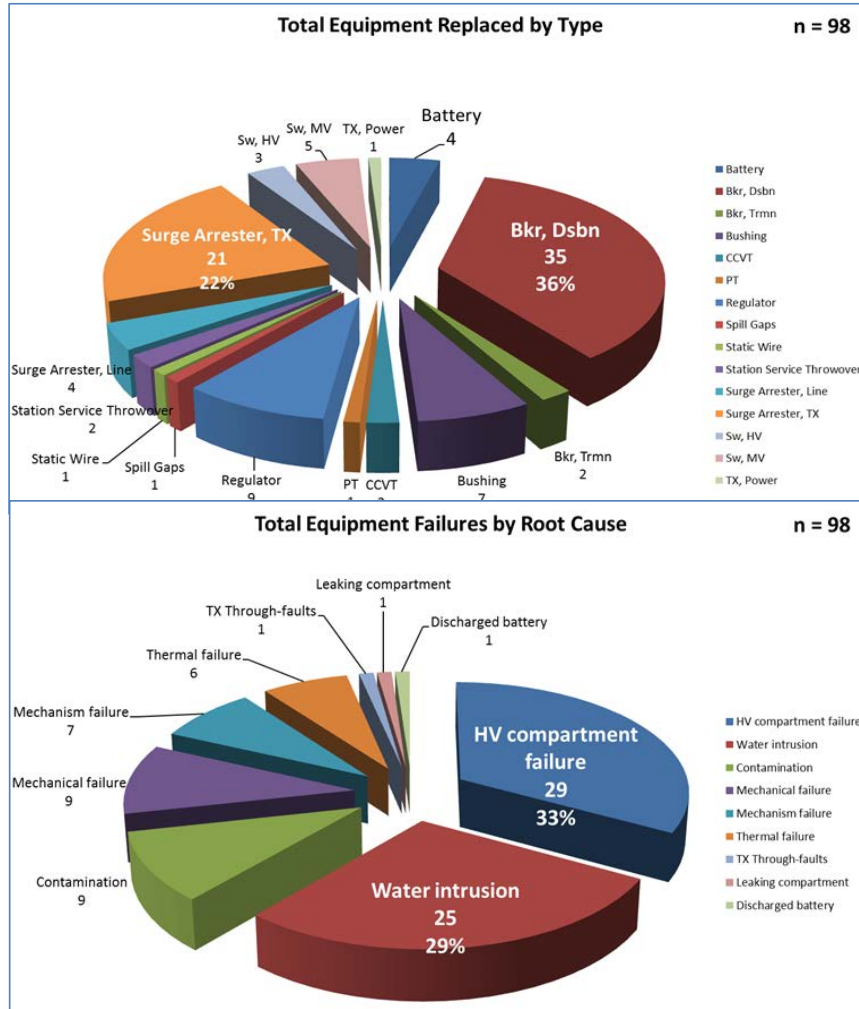

Equipment failures were dominated by feeder breaker failures during the storm and surge arrester failure post event. Most of the failures of the feeder breakers were a result of the High Voltage (HV) compartments flashing from water intrusion due to wind-blown rain. The surge arrester failures appear to be a latent failure mode with water intrusion and/or contamination due to the storm the most likely root cause of the failures occurring post storm after energization.



Substation Performance "Replacements by Area"

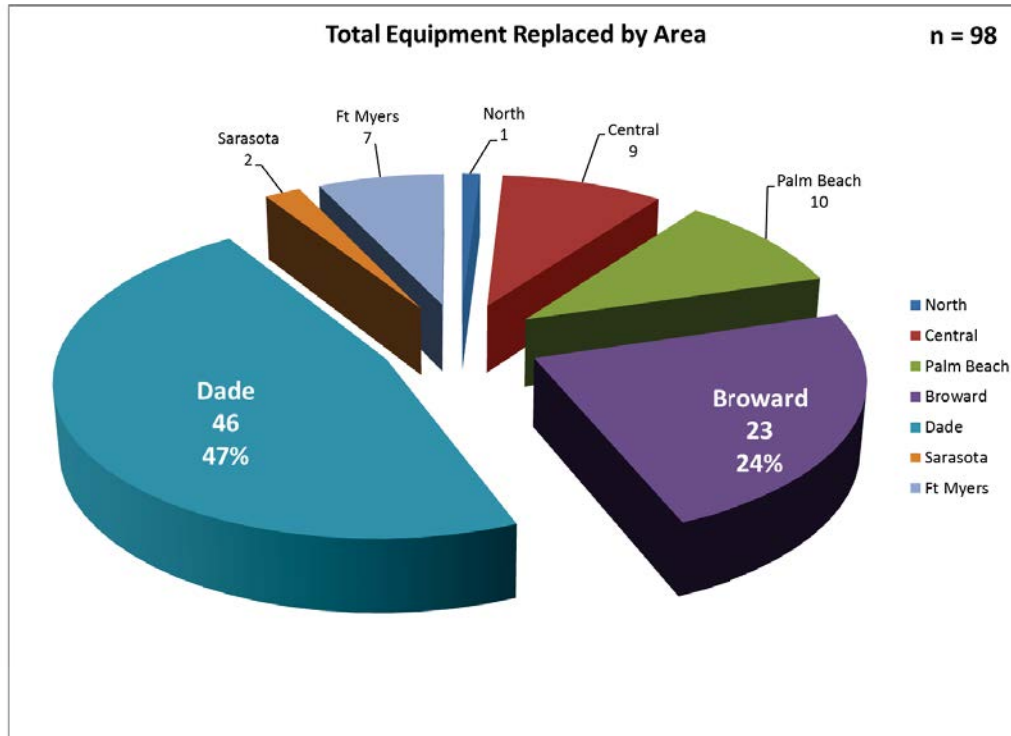

Substation performance by area was dominated by a significant impact to substations in the SE region of Florida. The importance of this impact resulted from the course of the storm as well as the duration of the event.



Protective Relay Performance

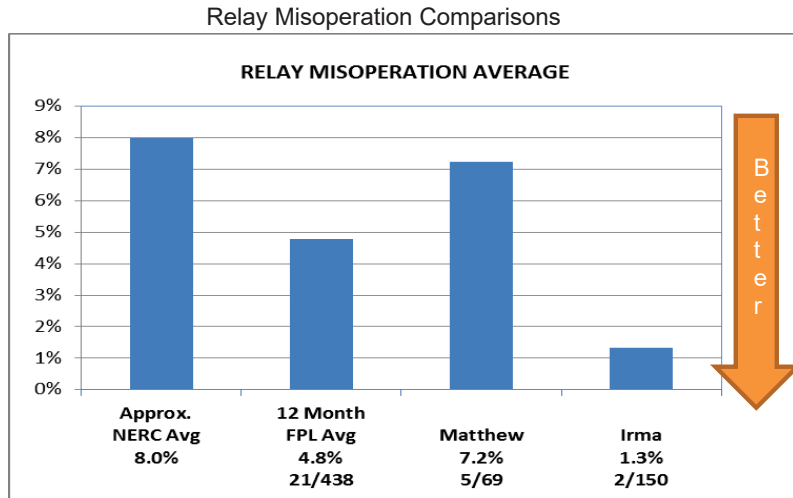

* A Relay Mis-operation is a failure to trip or tripping unnecessarily further defined by NERC PRC-004

Relay Misoperation Details for Irms	
Date Time	Event Description of Relay Misoperation
9/10/2017 3:04:52 PM	Ft Myers terminal of the Alico - Ft Myers #1 138kV line tripped for a Cph-Gnd fault on the Alico – Ft Myers #2 138kV line. Investigation is underway.
9/11/2017 9:54:04 AM	The Seminole terminal of the Putnam – Seminole 230kV line tripped for a B-C phase fault on the Korona – Putnam 230kV line. Seminole relay records indicated a pilot trip and no carrier received. Investigation at Putnam identified a failed power supply and an intermittent failure on the filter card of the RFL carrier set. This condition prevented the carrier blocking signal from being sent.



De-Energized Distribution Substations

92 Substations were de-energized. Below is a list of Substations, locations, and times.

Site	Date Deenergized (MM/DD/YYYY)	Area	Site	Date Deenergized (MM/DD/YYYY)	Area
Fairmont	9/10/2017 10:24	Broward	624a	9/11/2017 1:42	East
Jacaranda	9/10/2017 18:17		Aurora	9/11/2017 1:01	
Moffett	9/10/2017 12:22		Banana River	9/10/2017 23:58	
Motorola	9/10/2017 18:17		Brighton	9/10/2017 12:22	
Pembroke	9/10/2017 11:02		Cocoa	9/11/2017 1:44	
Pinehurst	9/10/2017 8:49		Cocoa Beach	9/11/2017 22:51	
Springtree	9/10/2017 18:17		Delta	9/11/2017 1:42	
Aventura	9/10/2017 12:22		Eau Gallie	9/11/2017 0:33	
Buena Vista	9/10/2017 11:20		Hibiscus	9/11/2017 1:01	
Dade Distribution	9/11/2017 14:13		Holland Park	9/10/2017 22:56	
Deauville	9/10/2017 8:05	Hutchinson Island	9/10/2017 22:40	North	
Haulover	9/10/2017 10:18	Indianantic	9/11/2017 1:13		
Indian Creek	9/10/2017 13:32	Indian Harbor	9/11/2017 1:13		
Key Biscayne	9/10/2017 12:32	Lighthouse	9/11/2017 0:54		
Killian	9/11/2017 19:25	Mars	9/11/2017 4:48		
Latin Quarter	9/10/2017 11:56	Merritt	9/11/2017 1:22		
Memorial	9/10/2017 13:17	Minuteman	9/10/2017 23:58		
Normandy Beach	9/10/2017 14:56	North Cape	9/11/2017 9:37		
Overtown	9/10/2017 12:49	Orsino	9/11/2017 4:48		
Virginia Key	9/10/2017 12:32	Patrick	9/11/2017 1:13		
Weston Village	9/10/2017 14:46	Rockledge	9/11/2017 1:44		
Belle Meade	9/10/2017 15:47	Satellite	9/11/2017 1:13		
Bonita Springs	9/10/2017 17:43	Slag	9/12/2017 2:07		
Capri	9/10/2017 16:02	South Cape	9/12/2017 0:48		
Gladiolus	9/10/2017 17:52	Suntree	9/11/2017 1:39		
Imperial	9/10/2017 17:43	Sweatt	9/10/2017 17:22		
Iona	9/10/2017 17:52	Sykes Creek	9/11/2017 1:22		
Orangetree	9/10/2017 16:21	Tropicana	9/12/2017 2:07		
Naples	9/10/2017 12:43	Windover	9/11/2017 1:39		
Rattlesnake	9/10/2017 16:02	Columbia	9/11/2017 5:59		
San Carlos	9/10/2017 13:16	Como	9/11/2017 0:35		
Summit	9/10/2017 16:21	Crescent City	9/11/2017 23:43		
Belvedere	9/11/2017 0:09	Deland Dist	9/10/2017 22:19		
Belle Glade	9/10/2017 15:05	Durbin	9/11/2017 5:46		
Congress	9/10/2017 17:05	Elkton	9/11/2017 10:41		
Deltrail	9/10/2017 16:01	Gumswamp	9/11/2017 5:59		
Hamlet	9/10/2017 16:17	Hastings	9/11/2017 6:03		
Hillcrest	9/10/2017 17:05	Kacie	9/11/2017 6:03		
Inlet	9/10/2017 23:06	Lake Butler	9/11/2017 5:58		
Juno Beach	9/10/2017 23:06	Live Oak	9/11/2017 4:26		
Lake Park	9/10/2017 23:06	Nash	9/11/2017 5:59		
Lantana	9/11/2017 8:23	Price	9/11/2017 5:58		
Norton	9/10/2017 17:05	South Daytona	9/11/2017 2:02		
Oscemill	9/11/2017 21:44	St Augustine	9/11/2017 1:08		
Quantum	9/11/2017 8:23	Tolomato	9/11/2017 5:46		
		Wellborn	9/11/2017 4:26		
		Wiremill	9/11/2017 5:59		



Case Study: De-Energized Substation Battery Voltage Monitoring

Battery performance is a concern when substations are deenergized for extended periods of time and lose multiple sources of AC station service used to charge the batteries. To manage the risk of batteries discharging below recoverable levels, battery voltage monitoring was performed from the PDDC on a periodic basis and logged. See table below.

During the first day, when the 92 substations were out of power, monitoring substation battery power is critical. Batteries power the breakers and protection equipment on the grid and allow remote opening and closing of breakers to restore the grid. Situational awareness of battery voltage to know how close a station was to having a significant backup power issue, provides information to Substation Rapid Responder teams which helps prioritize order of stations to visit.

This was a significant issue in Wilma in 2005, but thanks to remote monitoring, it was a not an issue in Irma.

Station	Area	Charger Off at Time	Charger Off at Date	Battery Voltage Alarm	Battery Voltage Readings from SEL Relays via PDDC				
					6:00	11:00	12:30	15:00	17:00
Deauville	Dade	8:00	10-Sep	8:06	118.3	n/a	n/a	n/a	n/a
Pembroke	Broward	11:05	10-Sep	11:05	118.9	125.8	127.4	128.7	
Overtown	Dade	12:49	10-Sep	20:22	117.7	115.32	123.52	124.99	
Brighton	Central	19:31	10-Sep	19:38	124.5	124.1	n/a	n/a	n/a
Minuteman	Central	21:16	10-Sep	21:18	119.1	n/a	n/a	n/a	
Deland	North	22:13	10-Sep	22:17	119.5	119.2	126.0	128.7	
Cocoa Beach	Central	22:45	10-Sep	2:03	121.6	120.3	126.0	128.8	
Sykes Creek	Central	0:15	11-Sep	0:18	113.6	122.6	125.2	126.9	
Banana River	Central			0:17	122.7	122.5	128.6	133.3	
St Augustine	North	1:12	11-Sep	1:59	122.3	132.1	133.1		133.3

Example of Substation Battery Voltage Readings taken during Irma while substation had no off-site AC power source. Monitoring substation battery voltage remotely from the PDDC helped to manage the priority of response to substation outages



Case Study: Insulator Contamination at St. Lucie

The likelihood of flashover is a function of the level of contamination building up along with weather conditions that produce dew or slight moisture to form on the insulation. FPL transmission rates insulator contamination levels based on the ESDD (Equivalent Salt Deposit Density) scale of 0 – 20. (Greater than 10 is at high risk for a flashover). Atmospheric conditions consisting of extended durations without adequate rain and exposure to winds from the sea or dust from nearby construction can lead to contamination build up. When these conditions change to allow moisture to accumulate on the insulator surface arcing and scintillations begin to erupt across the insulators.

Normal Operations (non-storm conditions)

- Monitoring of leakage current across insulators generally displays around 0.8 to 2.5 mA
- Level 10 and below on ESDD scale is considered to be a lower risk for flash over.
- Dry Salt on insulation does not create an immediate threat, however can represent a contamination exposure during early morning dew or a light rain.

Tropical Storm / Hurricane conditions

- Leakage currents will jump way up within close proximity to the coastline or other forms of atmospheric contamination.
- Contamination potential increases due to Florida's flat geography, higher storm winds and turbulent ocean waters blowing salt mist across the FPL system.
- At around 3 mA FPL monitors for contamination problems
- Level 10 and above on ESDD scale is considered to be a higher risk for flash over.
- Wet (liquefied) salt becomes an electrolyte and can cause insulation to flash

Although the Contamination Withstands Tools and Processes are effective for long term buildup of sea salt, there is little that can be done, from a process perspective, for sudden buildup events like hurricanes. In this event we went from a FPL scale of 0 (clean) just prior to storm to a FPL scale 20 (Very Heavy) in a matter of minutes/hours.

Strong evidence demonstrates that this may have been the most severe contamination event at St Lucie switchyard. Even the insulation on the transmission line towers outside of the station was experiencing scintillations. In addition, contamination assessment in early morning hours confirmed that most of the energized insulation was experiencing extreme scintillations. Unlike Hurricane Jeanne and Francis during Hurricane Irma there was no natural cleaning from rain on the back side of the storm.

Every early morning assessment 9/11 – 9/18 continued to demonstrate that the insulation contamination level was heavy. It was not until after the rain on the night of 9/18 that the insulation was effectively cleaned and transmission declared a rain wash base on the results of the early morning assessment of 9/19.

Along with the St Lucie switchyard and Hutchinson Island FPL experienced approximately 25 contamination flash overs along the east coast of Florida.

The initial St. Lucie station conditions were wet but drying insulation with still fairly high wind speeds. Scintillations were observed on all energized, 230kV breakers, Capacitive Coupled Voltage Transformers (CCVTs), and high tension pull-off insulators. Scintillations were running almost the entire length of the insulation and it is likely that the high winds were extinguishing the arcs before they could flash over.



Due to St. Lucie Switchyard proximity to the sea or otherwise exposure to strong winds from the sea, efforts have been made to improve the St. Lucie insulation contamination withstand capability. Because of these improvements St. Lucie switchyard insulation has successfully operated during heavy contamination levels of 11-16 on the FPL ESDD scale. Based off this operational experience we can conclude the contamination levels immediately post-storm were very high or at a level of 17-20 on the FPL ESDD scale.

The following equipment was out of service:

- Hutchinson Island #1 feed
- Hutchinson Island #2 feed
- Leakage current detector insulators (out from the loss of Hutchinson Island # 2)
- East 230kV bus
- Turnpike 230kV line (switched out by dispatcher for voltage control)
- 1B & 2B startup feed (out from loss of Hutchinson Island #1 and loss of East bus)

Key Points:

- All protective relay schemes operated as designed
- The insulation performed as expected based on the "Very Heavy" level of contamination
- crews were prompt and deliberate in the insulation cleaning
- Actual washing duration was better than or at target scheduled duration
- The insulation that was not cleaned performed well when the rain wash finally moved in, which is evidence that the insulation strategy is effective.

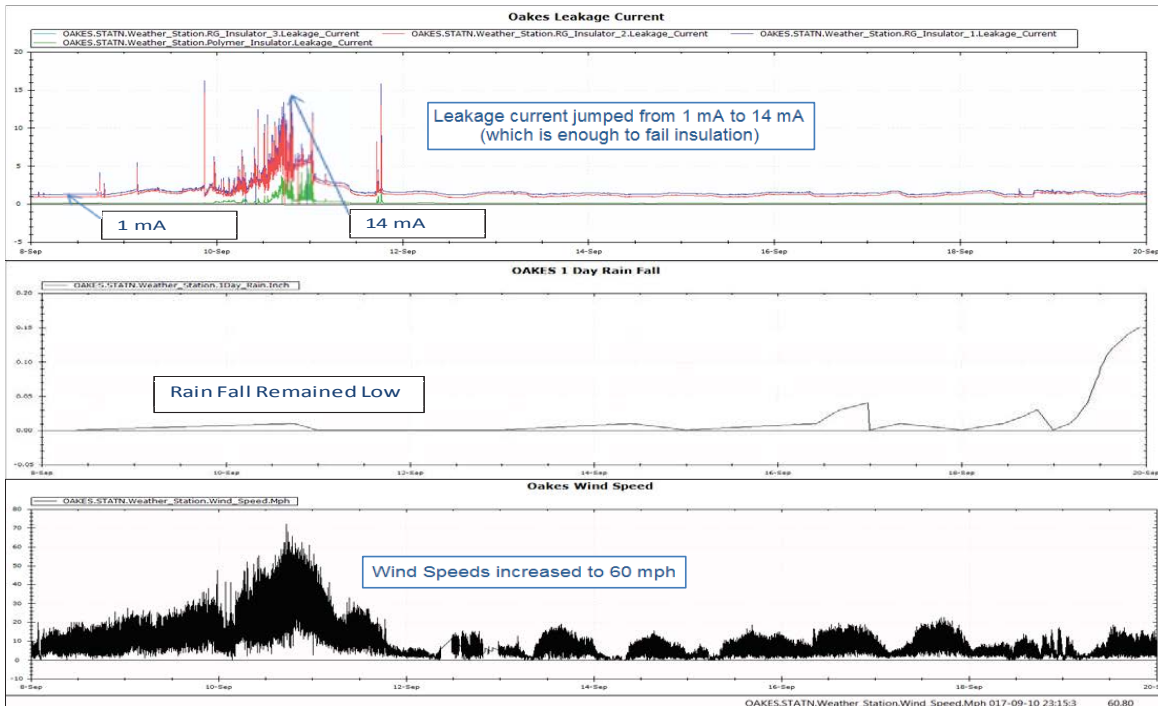

Above shows high winds and little or no rainfall caused contamination and increased leakage current to damaging levels.



Specific Event during the Storm – Hutchinson Island

Hutchinson Island #2 line terminal trips for a B-Phase fault on the 8F10 switch in Hutchinson Island. The switch was found in the closed position with flash marks across the shunt trip insulator on the B-Phase. The protective relays and the transmission breakers in the St. Lucie station operated as designed and de-energized the high voltage line and the feed to the transformer from the St. Lucie switchyard.

Data from the remote contamination monitor shows the pre-storm leakage current and the increase in leakage current as the storm winds blow salt contaminants onto the test insulators. The vertically mounted RG insulators measured 1.2 mA of leakage current pre-storm with the highest level of 31.2 mA achieved prior to the monitor being de-energized. The horizontally mounted polymer insulator had a similar increase signature starting at 0.18 mA and reached a maximum high of 25.2 mA. This data confirmed that the insulation system was clean pre-storm and the buildup was seen as the storm moved across the stations. The test insulators were de-energized and stopped supplying data when the Hutchinson Island #2 line was de-energized.

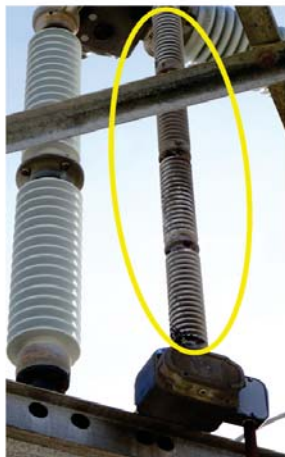

Contamination damage on F-switch

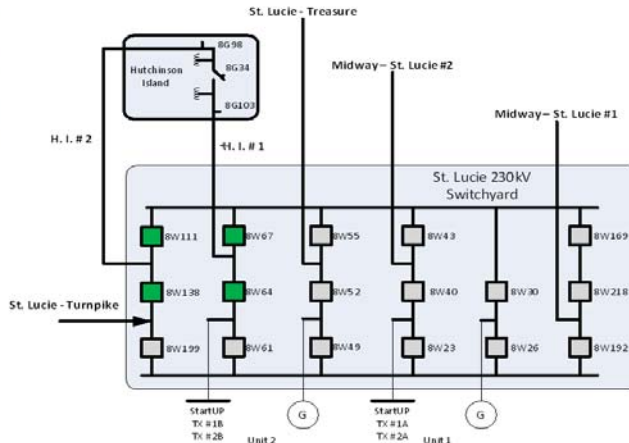

One-line showing Hutchenson Island breaker open

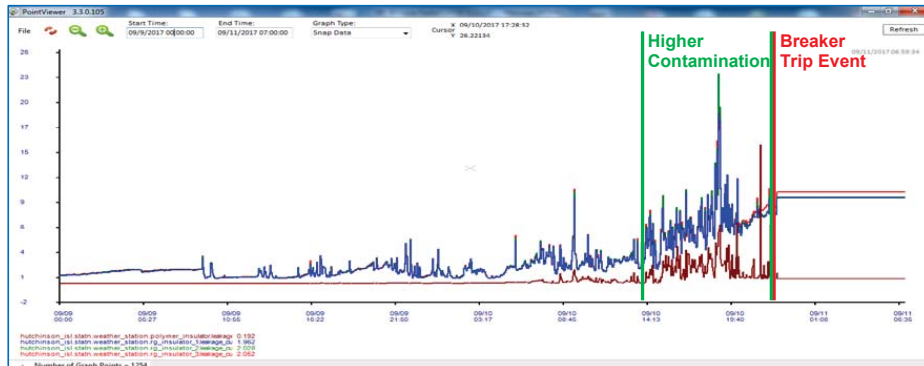

High contamination monitor reading correlates to time of breaker trip event.



Substation Flooding

Early substation flooding predictions were derived from NOAA SLOSH model runs using the predicted wind speed and direction.

Once National Hurricane Center storm specific storm surge predictions were issued substation flood damage was predicted by using 50% chance of exceedance inundation levels.

Post storm 5 substations were determined to be impacted by storm surge and 4 were impacted by rain event flooding with standing water.

Two substations set off emergency flood alarms and were pro-actively de-energized to prevent equipment damage:

- St. Augustine
- South Daytona

Only St. Augustine substation had damaged equipment related to flooding.

Utilizing the 50 percent exceedance prevented over prediction of impacted substation. However Irma path and intensity changed with each forecast and after landfall limiting the validity of the pre-landfall predictions.

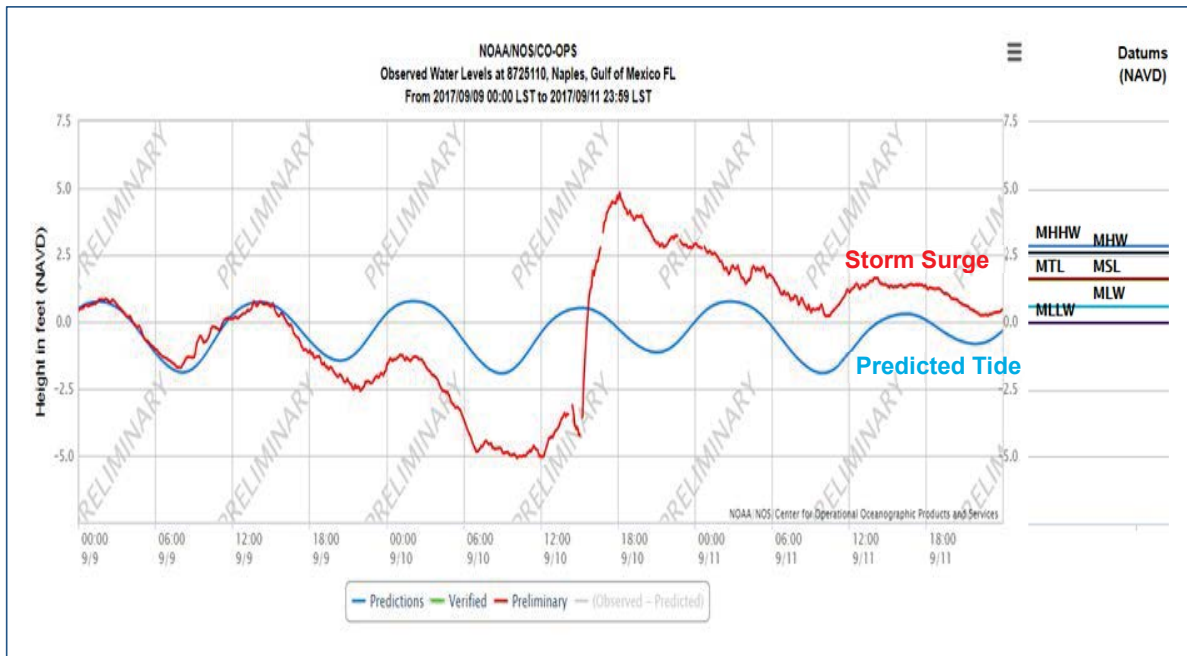

Surge peaked in a few hours and receded in more than one day. (Source: NOAA Tidal Gauge at Naples)



Substation Flooding Analysis

- 32 Stations of the 600 plus substations were at risk of flooding.
- **6 Substations were impacted with flood waters**
 - 3 water did not reach the flood alarm levels
 - Corkscrew, Ft. Myers and Lewis
 - 1 reached the first level "Warning" alarm
 - Pine Ridge
 - 2 reached the first and second level alarms, "Warning" and "Emergency"
 - St. Augustine and South Daytona
 - Both were proactively deenergized.



SUBSTATION FLOODING RESULTS - HURRICANE IRMA														
Substation	Area	Station Type	Wind Hardened	Cameras	Irma - NOAA Storm Predicted Surge Inundation (P50 from 11AM 9/9) (feet)	Irma - Substation Actual Impact	Irma Type	Irma Water Level Above Yard (feet)	Irma Water Level Above Vault Finish Floor (feet)	Relay Vault Storm Surge Hardened	Flood Monitors	Received Flood Monitor Warning Alarm?	De-Energized due to Flood monitors	Station Recommended for Storm Flood Mitigation (e.g. Sandbags)
South Daytona	North	D	1	1	None Predicted	Yes	Surge	0.53	0.48		1	Y	Y	
Ft Myers Plant	Ft Myers	T	1	1	0-2	Yes	Rain	0.60	0.00	1	1			N
Corkscrew	Ft Myers	D			None Predicted		Rain	0.85	0.00		1			
Pine Ridge	Ft Myers	D	1	1	0-2	Yes	Rain	0.72	0.01 (small puddle)		1	Y		
Lewis	North	D	1		None Predicted	Yes	Surge	1.13	0.00		1			
St Augustine	North	D	1		3-5	Yes	Surge	2.51	0.38 (Did not enter Vault)	1	1	Y	Y	
Alligator	Ft Myers	D	1	1	2-3	No					1			Y
Buckeye	Sarasota	D	1								1			Y
C5	Central	T	1								1			Y
Cocoplum	Sarasota	D	1	1							1			Y
Dania	Broward	D	1	1							1			Y
Edison	Ft Myers	D	1		2-3	No					1			Y
Franklin	Sarasota	D	1								1			Y
Ft Myers	Ft Myers	D	1								1			Y
Gladiolus	Ft Myers	D	1		3-5	No					1			Y
Homestead	Dade	D	1	1							1			Y
Indian Creek	Dade	D	1	1							1			Y
Iona	Ft Myers	D	1	1	7-9	No				1	1			N
Key Biscayne	Dade	D	1	1							1			Y
Knowlton	Dade	D	1	1							1			Y
McGregor	Dade	D	1	1						1	1			Y
Murdock	Sarasota	D	1	1							1			Y
Naples	Ft Myers	D	1		0 close to 5-7	No				1	1			N
Natural Bridge	Dade	D	1	1							1			Y
Notre Dame	Ft Myers	D	1								1			Y
Payne	Sarasota	D	1	1	2-3	No				1	1			N
Rotonda	Sarasota	D	1								1			Y
Snapper Creek	Dade	D	1	1							1			Y
Tice	Ft Myers	D			0-2	No					1			Y
Whispering Pines	Dade	D	1	1							1			Y
Belle Meade	Ft Myers	D	1		9-11	No				1	1			N

	Flood water near equipment
	Flood water impacted equipment
	Recommended flood hardening improvements



Case Study - St. Augustine Flooding

Station flood monitor warning alarmed at 12:26 am on 9/11

Station flood monitor emergency alarmed shortly after at 1:00 am

Both outdoor flood monitor alarms cleared at 8:53 pm

Date Time EST	Station	Event	Src
09/11/2017 01:00:50	St_Augustine	Statn Flood_Monitor Emrg Alarm	T
09/11/2017 01:00:26	St_Augustine	Statn Flood_Monitor Emrg Normal	T
09/11/2017 01:00:24	St_Augustine	Statn Flood_Monitor Emrg Alarm	T
09/11/2017 00:29:38	St_Augustine	Statn Flood_Monitor Warn Alarm	T
09/11/2017 00:29:36	St_Augustine	Statn Flood_Monitor Warn Normal	T
09/11/2017 00:29:32	St_Augustine	Statn Flood_Monitor Warn Alarm	T

Alarm log for St. Augustine Substation



St. Augustine Substation

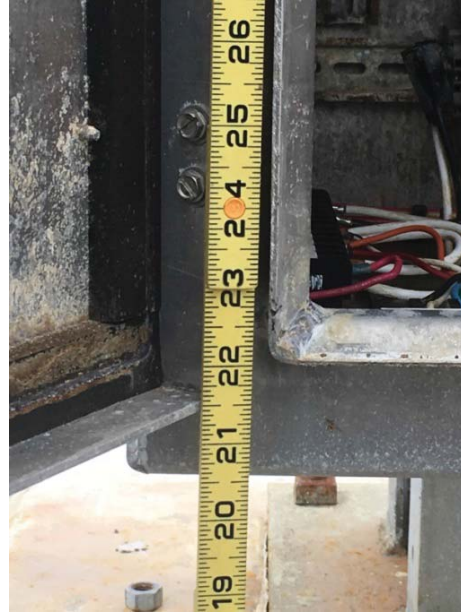

Feeder Breakers with water intrusion



Fault bus CT's were submerged throughout entire substation



Examples of St. Augustine Substation motor operator impacted by storm surge

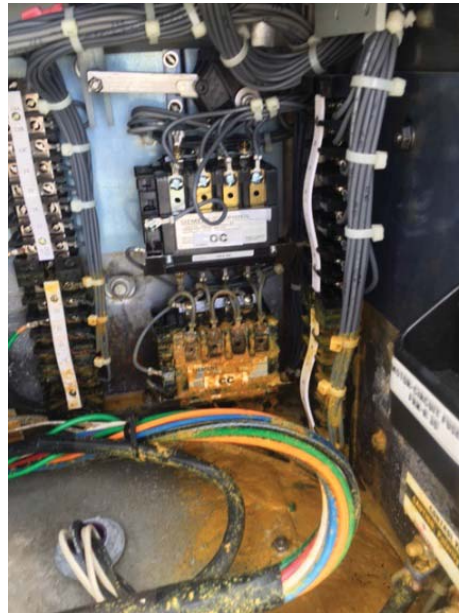



Case Study - South Daytona Flooding

Station flood monitor warning alarm set off at 1:21 am on 9/11



Station flood monitor emergency alarm set off at 2:27 am



Both outdoor flood monitor alarms cleared at 6:57 pm

Date Time EST ^	Station	Event	Src
09/11/2017 06:57:28	South_Daytona	Statn Flood_Monitor Warn Normal	T
09/11/2017 02:27:42	South_Daytona	Statn Flood_Monitor Emrg Alarm	T
09/11/2017 01:22:02	South_Daytona	Statn Flood_Monitor Warn Alarm	T
09/11/2017 01:21:51	South_Daytona	Statn Flood_Monitor Warn Normal	T
09/11/2017 01:21:26	South_Daytona	Statn Flood_Monitor Warn Alarm	T

Alarm log for South Daytona Substation



South Daytona Substation and Flood Warning Monitors



Examples of South Daytona Substation Damage inside the vault

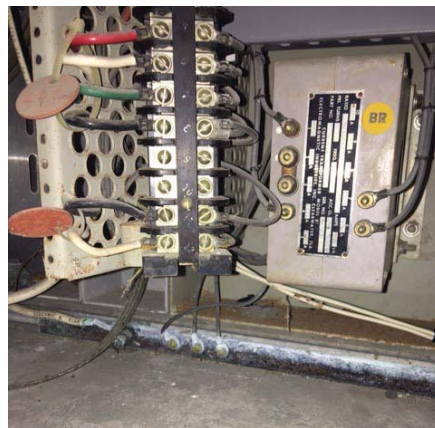
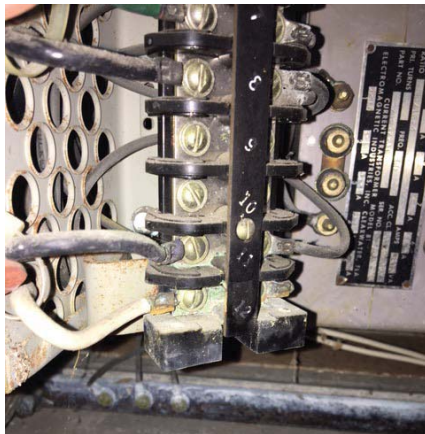

Flood waters reached 5 1/2" on the inside of the relay vault and affected ground bus and some connections





Case Study – Pine Ridge Flooding

Pine Ridge station order of events

- Flood monitor warning alarmed at 5:13PM on 09/10*
- Both outdoor flood monitor alarms cleared at 5:18PM
- Rain Flooding .72 Ft. above average yard grade

* Only first level “warning” alarm asserted and second level “emergency” alarm did not assert; therefore, station was not deenergized.

Relay vault does not have flood doors, which allowed flooding to occur inside vault

- Rain Flooding .01 Ft. above Relay Vault small puddle on floor.



Pine Ridge Substation rain event flooding



Examples of Pine Ridge Substation

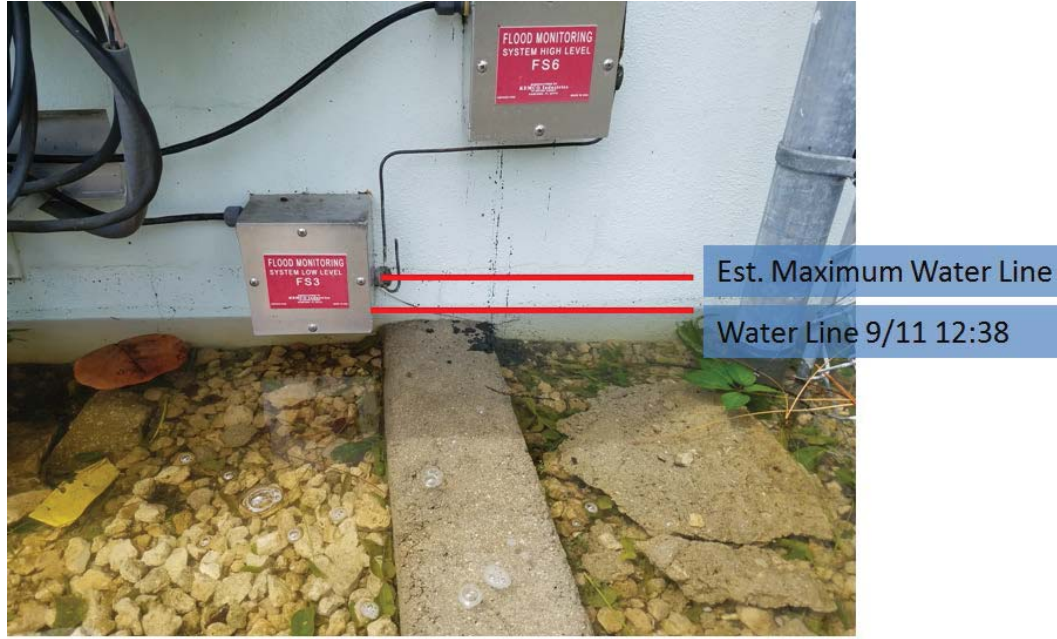

Pine Ridge Substation Flood Monitoring



Pine Ridge Substation Flooding



Case Study – Corkscrew Flooding

Corkscrew Sub and Corkscrew Access drive (patrol road) flooded, including surrounding area and adjacent subdivision, however homes seems to be above flood levels.

- Flood waters from adjacent property impacted FPL property
- P&C van became stuck on Access drive attempting to access the substation
- Substation was only accessible by off road vehicles
- Rain flooding reported to be 1.5 Ft. to 2 Ft. above access drive.
- Rain flooding inside substation is 0.65 Ft. above average yard grade
- Relay vault does not have flood doors
- Rain flooding did not enter Relay Vault



Corkscrew Substation Rain Event Flooding



Corkscrew Access Drive



Case Study – Substation Fence and Gate Damage

A total of 48 substations sustained physical facility damage during Hurricane Irma. Below is the breakdown of the types of components impacted.

Facility Component	Qty
Building Exterior	1
Roof Air Extractors	4
Overhead Door	2
Decorative Sliding Gate	2
Substation Fence Damage	37
Swing Gate	4
Vault Door	1
Property Fence	2

Note that some substations had more than one type of component impacted. Below are examples of physical damage.



Indian Creek Substation – Roof Exhaust Fan

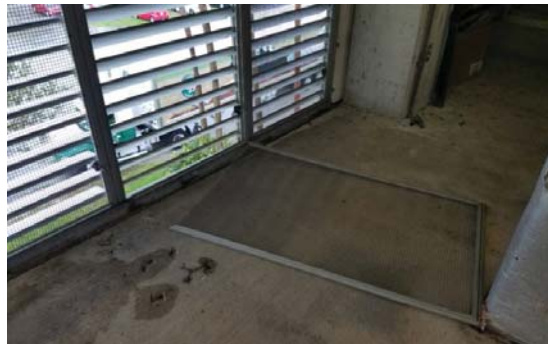

Watkins Substation – Louver Screen



Crystal River Substation – Fence



Watkins Substation – Roof Exhaust Fan

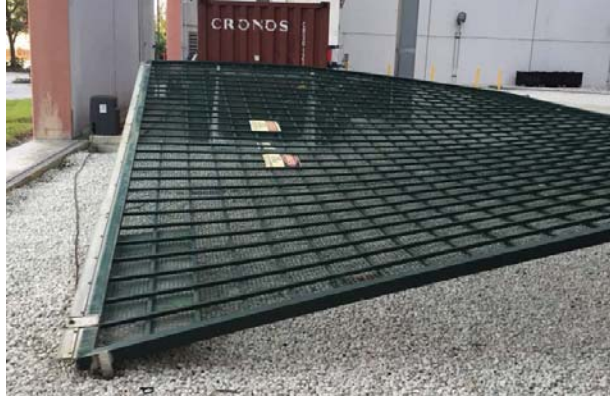

Natural Bridge Substation – Gate



Watkins Substation – Overhead Door



Watkins Substation – Overhead Door



Case Study – Belle Meade LCEC Shed Damaged Substation Equipment

No evidence of flooding in station and no flood monitor alarm. Capri Sub did have evidence of flooding, so there may have been flooding in Belle Meade with no evidence found.

Large debris found in substation (part of shed and wood light pole from LCEC yard).

Current design, 150mph-gust-wind-designed fence partially damaged in areas due to flying debris and failing LCEC wood light pole.

Switch jumper was damaged/disconnected due to debris from LCEC.

Station and fence performed well even with the large debris impact. Station and fence were designed to FPL current design criteria.



Belle Meade Substation (Looking East) adjacent to LCEC yard (Lee County Electric Coop)



Belle Meade Substation (Looking West)



Belle Meade Substation (Looking West)



Belle Meade Substation (Looking East)

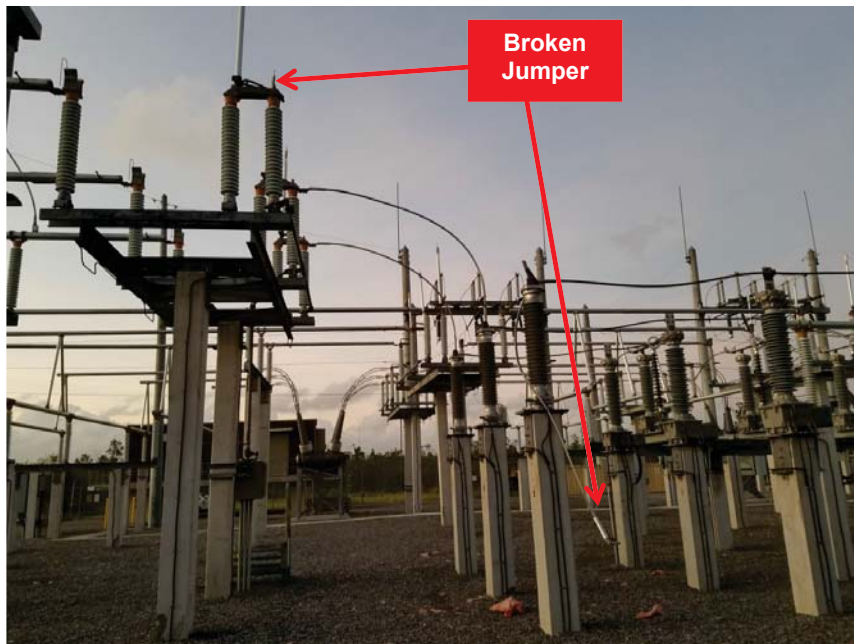

Belle Meade Substation



Distribution Substation Transformers Experiencing Through Fault Levels

As the effects of Irma were impacting our system, the grid experienced several thousand system wide faults. The faults created excessive mechanical wear on our breakers and switches and the impact on the overall grid was substantial. The long term effects are especially impactful to our fleet transformers.

FPL had 452 transformers that experienced more than 20 faults throughout the duration of Irma's impact to our service territory. Typically, transformers see one or two faults per year and are designed to withstand the thermal stresses and mechanical forces that are produced when a fault occurs, but repeated frequent faults can adversely affect the transformer's capabilities.

In addition, a subset of these 452 transformers experienced through faults with high fault currents exceeding 600A as wind driven rain and contamination circumvented the fault current limiting reactors installed to mitigate the fault levels.

2 transformers failed; one at Crystal and one at Mallard. See details on following pages. Below is a list of 15 transformers that experienced several successive high fault levels in excess of 7,000A. These transformers passed a Kelman oil test before being placed back in service. This data is included into the transformers risk profile:

Substation	Transformer
40 th St.	T-0962
Haulover	T-0097
Haulover	T-0966
Indian Creek	T-0964
Indian Creek	T-0967
Market	T-3176
Market	T-3207
Miami Bch	T-1742
Miami Bch	T-2266
Miami Bch	T-2529
Normandy Bch	T-0965
Normandy Bch	T-1346
Railway	T-2772
Venetian	T-0742
Venetian	T-0968



Damaging Effects of Faults

- Well-designed transformers are built to withstand a through-fault which is usually around 6 or 7 times the rated current.
- When a fault occurs, the windings and clamping structure are subjected to mechanical and thermal stresses.
 - The mechanical stresses are a function of the electro-magnetic forces from the current and are proportional to the current magnitude squared.
 - The thermal stresses are also a function of the current magnitude squared.
- Transformers are not designed to withstand numerous faults, especially during a short time period.
 - The mechanical forces act to compress winding spacers and loosen clamping which weakens the transformer's ability to withstand future faults
 - Thermal stresses are significantly increased when multiple faults occur in a short time because the windings do not have sufficient time to cool back down between faults. This will accelerate the insulation aging or permanently damage the insulation, leading to electrical failure.
- All of the transformers that had significant number of high current faults during the storm have reduced fault withstand capability as a result of the cumulative mechanical and thermal stresses from the faults
- This graph illustrates the reduction in insulation strength due to stresses from multiple fault incidents.

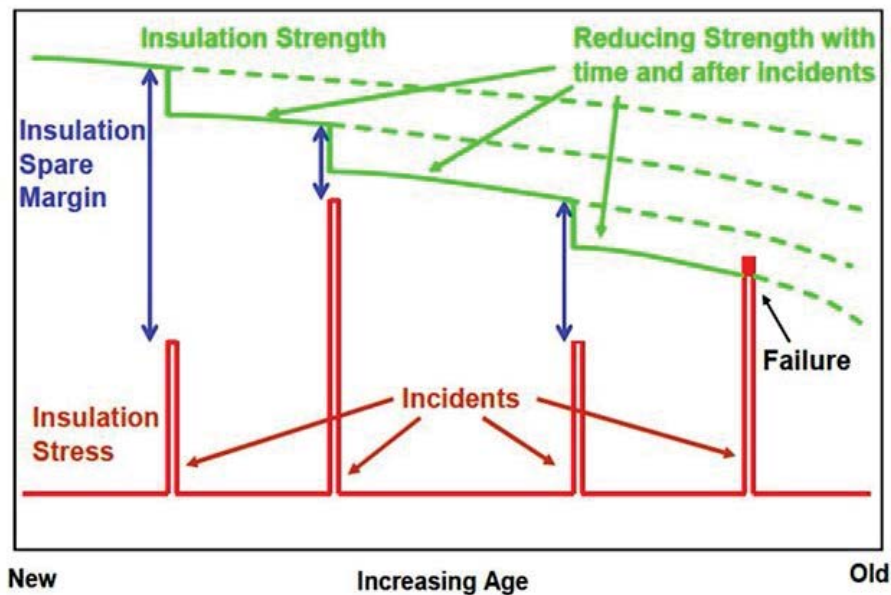

A conceptual failure model proposed by CIGRE WG 12.18 [7,8]



Case Study: Analysis of Failed Transformers

Faults create thermal and mechanical stresses. All of the Transformers at Crystal and Mallard had significant number of high current faults during the storm and failed due to their reduced fault withstand capability as a result of the cumulative mechanical and thermal stresses from the faults

	Crystal	Mallard
Total I ² t A ² seconds	3,400,249	5,669,606
Times the cumulative thermal energy that the transformers were each designed to withstand, assuming equal stress on each of the transformers	3.4	3.9

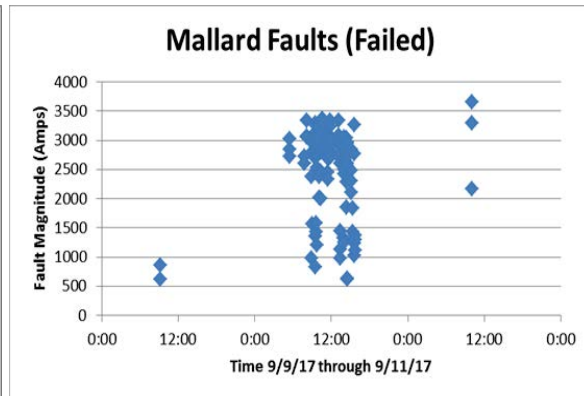
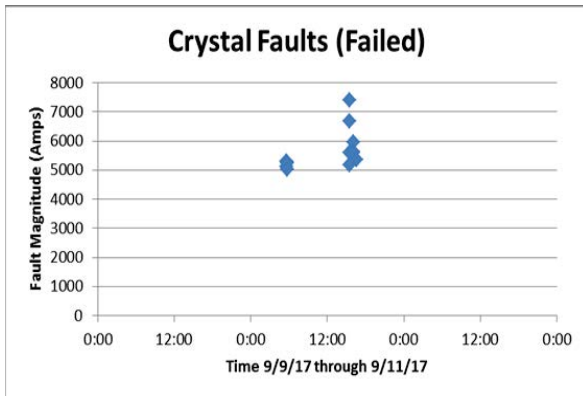



Distribution Performance

Distribution System performed well in Irma and demonstrated the investments in the Distribution Hardening Program, Pole Inspection Program (PIP) and Smart Grid have helped reduce the number and severity of outages during Hurricane Irma. This was key to improved speed of restoration.

Pole Summary

- Hardened Feeder Poles Down 26 (0.02%)
- Non-Hardened Poles Down 2,834 (0.20%)
- Poles Down 2860 (Feeder, Lateral, Service, Telephone)
 - Poles replaced during restoration
- Pole damage was primarily due to fallen trees
- Flooding and debris caused issues to a much lesser degree
- Overall pole performance was significantly better than previous storms

Hardened vs non-Hardened Feeder Performance Summary

	non-Hardened	Hardened	Improvement
Pole Failure Rate	0.20%	0.02%	10 X Better
CMH to Restore	105	52	2 X Better
Feeders Out	82%	69%	1.19 X Better

Feeder Summary

	Affected	% Affected
• Feeders Out	2,286	70%
○ UG	85	19%
○ Hardened	592	69%
○ Non-Hardened	1,609	82%

Excludes outages caused by Transmission and Substation

Hardened Feeder Summary

- 26 Hardened Feeder Poles were down out of 124,518 hardened poles on 859 Hardened Feeders.
- Hardened Feeders performed 1.19 times better than non-Hardened Feeders
- The primary objective of hardening is to reduce restoration times by minimizing the number of pole failures during extreme wind weather events.
- Hardened Feeders took half as much time to restore than non-Hardened Feeders
- On average Hardened Feeders had 13 damage findings vs. 18 damage findings on non-Hardened Feeders



Lateral Summary

	Affected	% Affected
• Laterals Out	24,108	13%
○ OH	20,341	24%
○ UG	3,767	4%

- Underground Laterals perform 6.6X times better than Overhead Laterals.
- Overhead Laterals averaged an outage every 1.1mile vs. Overhead Feeders averaged and outage every 5.3 miles.
- Vegetation is leading cause of Overhead Lateral outages
- Flooding or vegetation(roots) are leading cause for Underground outages
- Excludes outages caused by Feeder, Substation or Transmission outages

Smart Grid Summary

- Self-Healing AFS (Automated Feeder Switch) operations avoided 546,000 Customer Interruptions during the storm.



Hurricane Irma hits Biscayne Bay in Miami on Sept. 10, 2017. Wilfredo Lee – AP



Pole Performance

Distribution Poles performed well in Irma. Hardened poles performed 10-times better than non-hardened poles and Non-Hardened poles performed better than previous storms. Fewer total poles replaced and shorter time to restore show that the system performs better for storm.

40% of pole failures were in the West area. In addition to Irma's impact, this area experienced record rainfall of over 16 inches in 3 days just 2 weeks before Irma. This combined with Hurricane Irma's impact led to a high uprooting of trees which was a main cause of pole failures.

- 26 Hardened Feeder poles down
 - Zero hardened concrete poles down
- 2860 Total poles replaced to restore power

Hardening Pole Programs

- Storm Hardening Plan: 124,518 poles have been hardened
- Pole Inspection Program: Inspection of Feeder and Lateral poles resulted in replacement of over 80,000 poles and reinforcement of nearly 50,000

Region	FPL Concrete	FPL Wood	FPL Total	Tele- phone	Total Poles	Broken + Down in ESDA	Total Poles to Restore	Pole Failure Rate
Broward	24,289	76,817	101,106	46,206	147,312	104	148	0.10%
Dade	27,554	120,441	147,995	60,961	208,956	649	828	0.40%
East	16,430	128,970	145,400	42,719	188,119	226	285	0.15%
North	23,556	434,659	458,215	75,113	533,328	300	507	0.10%
West	13,317	302,309	315,626	7,000	322,626	822	1,092	0.34%
Total	105,146	1,063,196	1,168,342	231,999	1,400,341	2,101	2,860	0.20%

Distribution Pole Failure %			
Pole Type	Failures	Total # of Poles	Failure Rate
Hardened Feeders	26	124,518	0.02%
non-Hardened Feeder	585	286,482	0.20%
Telephone	511 *	231,000	N/A
Lateral / Service	1,738	758,341	0.22%
Overall	2,860	1,400,341	0.20%

* Telephone Company Poles replaced by FPL

Extrapolation Assumptions below

1. Includes all poles reported in ESDA as broken or down which includes Feeders, Laterals, Service, and Telephone.
2. Feeder Outage Duration < 24 hours excluded - Assumed no poles down or broken
3. Extrapolate to population based on sample size for the area



General Pole Performance by Failure Type

Survey of 33 Forensic Patrollers for Hurricane Irma. Damage was based on information from patrols and pictures were used to verify accurate categorization.

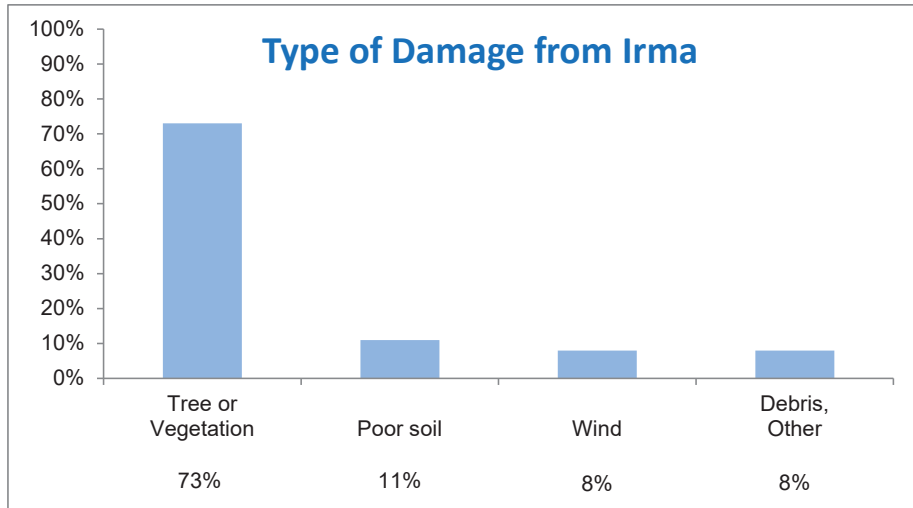



Hardened vs non-Hardened Pole Performance

The investments in the distribution hardening program, pole inspection program (PIP) and smart grid have helped reduce the number and severity of outages during hurricane Irma.

The severity of damage was minimized and the speed of restoration was faster due to the efforts of the hardening programs that FPL has employed.

FPL's total pole down/broken count for Irma is 2,860 with only 26 being Hardened Poles. Pole damage was primarily due to fallen trees. Flooding and debris caused issues to a much lesser degree. This performance is significantly better than previous storms.

Distribution Pole Failure %			
Pole Types	Failures	Total # of Poles	Failure Rate
Hardened Feeder	26	124,518	0.02%
non-Hardened Feeder	585	286,482	0.20%

Hardening Works

Data shows there was a statistical difference in performance between Hardened and non-Hardened Feeder outages since the p-value < .05.

Analysis that shows the defect rate of non-Hardened and Hardened Feeder poles is significantly different.

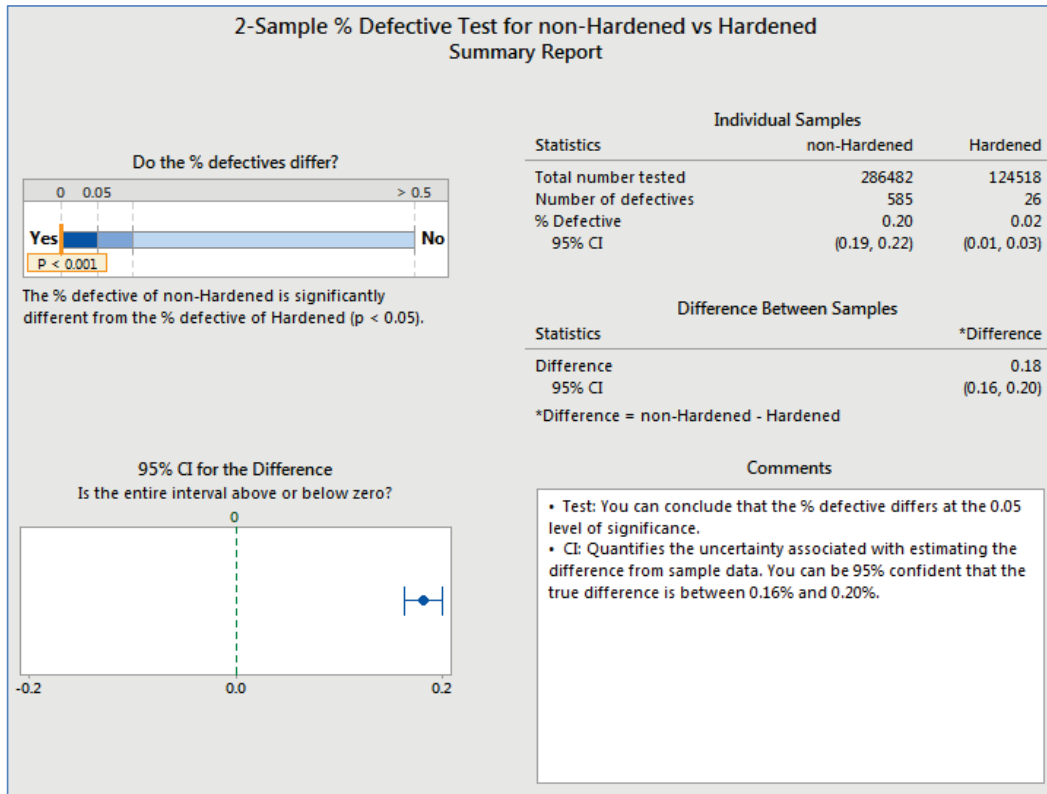



Hardened Pole Failure Analysis

- 26 Hardened Feeder poles (all wood) were down or broken out of the 859 Hardened Feeders
- This is a 0.02% failure rate compared to 0.2% for all poles
- 9 Trees, 9 Poor Soil and possibly a set depth issue, 3 cascade, 5 other

Hardened Pole Failure Analysis (from ESDA)														
Feeder	Substation	Official Hardening Date	Region	Poles Down	Poles Broken	Poles Leaning	Comments	Cause - Tree	Cause - Debris	Cause - Wind	Cause - Soil/Fnd	Cause - Other/ unknown such as defect, deterioration, pole fire, overloaded, poor guy/ing	Cause - Secondary Failure (Cascade)	
503564	ALLIGATOR	3/31/2015	West		2		Tree	2						
504061	CAPRI	9/23/2016	West	1	11		Debris and micro extreme wind event in trailer park		1					
503261	COCOPLUM	6/30/2015	West		1		Pole broken 10' from the ground. Not cause for outage, no obvious cause for outage beyond wind. Likely pre-existing material defect in pole.					1		
500765	ENGLEWOOD	5/31/2009	West		2		Tree broke tops of 2 poles	2						
508463	GATEWAY	6/30/2014	West		1		Pole Fire damaged top of pole					1		
560166	METRO	9/24/2010	West		1		Tree came down on line	1						
507761	RATTLESNAKE	11/12/2009	West		1		Pole broken 3-6' from the ground, normally open ScadaMate switch					1		
102361	TERRY	5/1/2014	West	9		9	Potentially Shallow set depths and extreme saturated soil conditions lead to failures (9 additional poles leaning)				9			
800432	LIVE OAK	9/24/2009	North		1		Live Oak tree on adjacent span fell on phone trunk snapping pole	1						
300633	MATANZAS	12/21/2013	North		1		Tree damage - tornado in area	1						
102532	ST JOE	1/6/2015	North		1		Two trees on feeder	1						
508362	BELLE GLADE	12/19/2008	EAST		4		Failure of one pole caused cascade of 3 other broken poles. Poles broken from the cascade snapped 0 to 10 ft above grade.					1	3	
400934	COCONUT GROVE	10/25/2007	Dade		1		Large tree fell directly onto pole causing it to break	1						
Totals					10	16	20		9	1	0	9	4	3
					26				26					



Telephone Pole Performance

- ESDA data of Telephone pole failure rate.
- Poles owned by Telephone companies and with FPL facilities.
- Telephone poles replaced by FPL

Region	Total Poles Extrapolated from Patrolled	Telephone Pole Replaced	% Telephone Pole Replaced
Broward	148	50	
Dade	828	282	
East	285	71	
North	507	86	
West	1092	22	
Total	2860	511	18%

Total w/o West	1768	489	28%
Total without the west region is calculated for comparison reasons due to the low number of Telephone poles.			



Case Study – Terry 508362 - Side Guying Failed Causing Leaning Poles

Nine hardened FPL wood poles with foreign attachments leaned or were laid over on the Terry 508362 Feeder.

The area experienced wind speeds in the range of 81-100 mph gust wind speeds. These poles were designed to 130mph wind gusts given the date of the hardening project.

It was reported that the heavy rain in the weeks prior to the storm had left the soil fully saturated which also reduces the foundation capacity. Also, the poles appear to have been set shallow.

The anchors on the structure at the northern end of the failure pulled out of the soil. The anchors were set in a berm with a small pond behind. No extensions were utilized on the anchors. The shallow installation depth into a berm would significantly reduce the holding capacity of the anchor particularly in saturation soil.

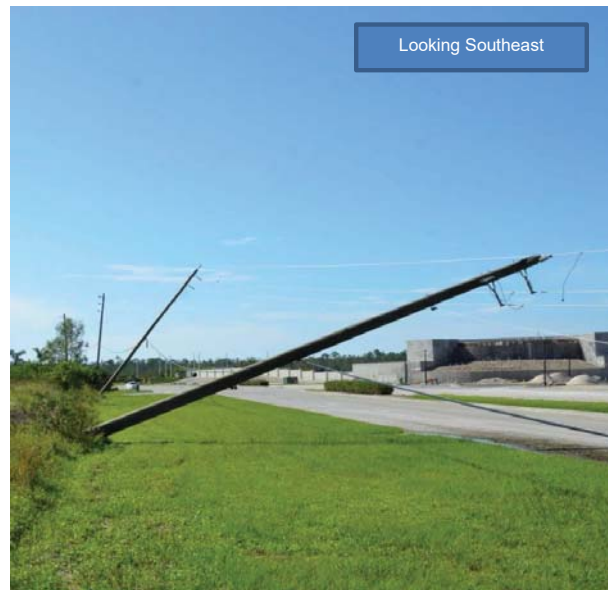



Case Study – Capri 504061 – Leaning and Down Poles due to Trailer Park Debris

11 FPL Hardened Feeder poles (10 wood, 1 concrete) with foreign attachments were leaning and 1 pole (wood) was down on the Capri 504061 Feeder due to high winds and debris from the adjacent trailer park.

The area experienced wind speeds in the range of 81-130 mph gust wind speeds. These poles were designed to 145mph wind gusts given the date of the hardening project.

The poles leaned over when impacted by debris from the trailer park. Debris seemed to be from structures immediately adjacent to the line.

The soil is soft in the area. There is a small ditch next to the poles and there may be a layer of muck that would decrease the effective setting depth.

There is evidence of potential areas of enhanced wind events from the drone investigation, but the areas of impact have such small impact areas (less than 300 feet in most locations of this area), the manufactured homes and the additions that are made to them are so susceptible to damage in high wind, and the gusts from the hurricane force winds themselves are so powerful that it is difficult to be definitive here.

No poles broke and all were able to be straightened and reset. Cross-arms, wires, and equipment were damaged and would need to be replaced.



Pole down with transformer in West area due to trailer park debris



Debris wrapped around pole in line.



Insulator tie and failed splice. Below: ALS out of support and on ground



View of leaning poles



Leaning concrete pole



Base of leaning concrete pole



Area of concentrated damage, looking west.



Looking northwest through the trailer park toward the feeder



Indications of enhanced wind activity



Looking south along feeder.



Feeder Performance

Underground Feeders performed better than Overhead Feeders. Hybrid Feeders performed similar to Overhead Feeders because Hybrid Feeders are a combination of OH and UG.

Feeder Performance by Feeder Type

Feeder	Type	Affected	Population	% Affected
UG	Network	0	11	0%
UG	Duct / Manhole	54	314	17%
UG	Other	23	85	27%
UG	URD	8	60	13%
OH / UG / Hybrid	Hardened	592	859	69%
OH / Hybrid	non-Hardened	1,609	1,958	82%
Total		2,286	3,287	70%

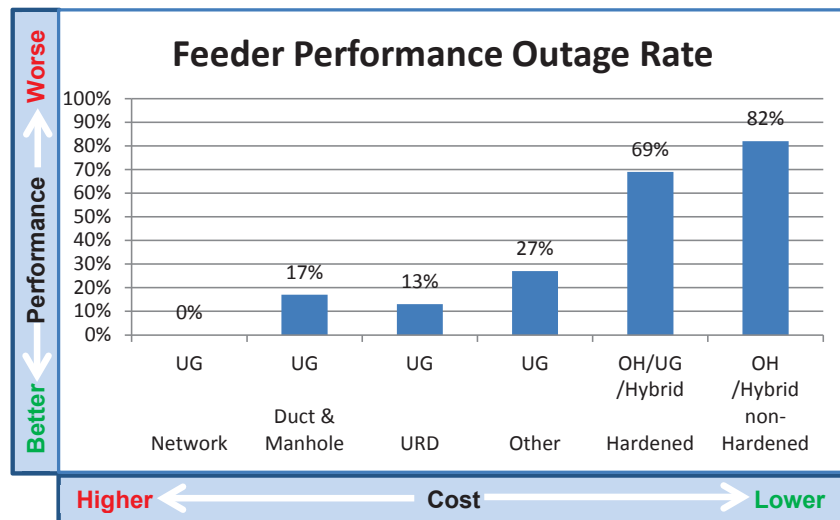

- Notes: - Excludes Transmission and Substation Outages
- OH Hardened Feeder includes OH-to-UG conversions as a part of Hardening
- Source is Carver Data on 9/22/17 at 7:00 am

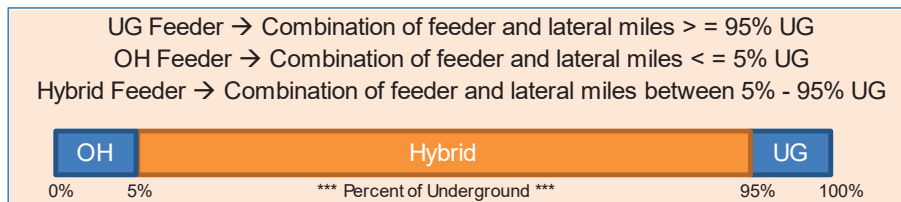

Definition of Purely Overhead (OH), Purely Underground(UG) and Hybrid Feeders



Hardened vs non-Hardened Feeder Performance

Hardened Feeders performed better than non-Hardened Feeders during Hurricane Irma

- While Hardened Feeders make up 26% of the Feeder population, Hardened Feeders sustained less pole damage accounting for only 0.9% (26 out of 2860) of the poles down or broken
- Based on less damage sustained, Hardened Feeders took 50% less resource-time to restore than non-Hardened Feeders
- Hardened Feeders performed 1.19 times better than non-Hardened Feeders
- Primary cause of pole failures and feeder outages was due to vegetation
- Forensic teams inspected all poles from the 859 Hardened Feeders
- Based on the assessment of outage performance Hardened Feeders performed 1.19 times better than non-Hardened Feeders

Hardened Feeder Performance Ratio	=	$\frac{\text{Number of Non-Hardened Feeders Out*}}{\text{Total Number of Non-Hardened Feeders}}$	to	$\frac{\text{Number of Hardened Feeders Out*}}{\text{Total Number of Hardened Feeders}}$
* Affected = Feeders out at least one time				

$$\frac{1,609 / 1,958}{592 / 859} = \frac{.82}{.69} = 1.19 \text{ X Better}$$

Hardened Feeders Performed 1.19 Times Better Than Non-Hardened Feeders



Hardened vs non-Hardened Average Time to Restore

Hardened Feeders have performed better both on outages and damage, thus we are seeing that they take half the time to restore. An assessment of Construction Man Hours (CMH) was performed to convey the benefits of Feeder Hardening.

Approach:

1. A survey was conducted of 100+ Irma Production Leads to assess the CMH associated with major work types for the storm
2. Electric Storm Damage Assessment (ESDA) data was utilized to characterize the major types of damage on Feeders impacted
3. Merging the CMH survey results to actual damage reported provides an estimate of the CMH required to restore major work on Hardened Feeders (52 CMH) vs. non-Hardened Feeders (105 CMH)

Damage	ESDA Conditions per Feeder		CMH to Resolve each Condition	Estimated CMH to Restore	
	Hardened Feeder	non-Hard Feeder		Hardened Feeder	non-Hard Feeder
Transformer	1.19	1.77	3	3.6	5.3
Wire	2.07	4.05	11.3	23.4	45.8
Pole Leaning	0.47	0.75	14.1	6.6	10.5
Pole Down / Broken	0.04	0.94	18.1	0.7	17
Tree	1.51	2.17	11.9	17.9	25.9
Total	5.27	9.68		52.2	104.5

½ the time to restore

- Capacitor, customer, fuse, unclassified pole, and recloser conditions for feeders in ESDA are not considered major work categories to restore the feeder and thus no CMH was assigned
- Half of non-broken poles were replaced; half were reset. Thus an average of pole leaning CMH and pole broken CMH were used
- Counts of Hardened poles down & broken is per Forensics analysis. All other data sources are ESDA (non-Forensics) on 9/20/17 7AM



Examples of Hardened and non-Hardened Feeders

Hardened Feeder

- Wires down, but not the poles will result in quicker restoration.
- Boca Raton Area



Non-Hardened Feeder (independent of the above Hardened Feeder)

- Leaning poles due to soft / saturated ground
- Carlstrom 5961 (Ft. Myers / Arcadia Area)





Case Study – Hardened vs non-Hardened Poles within a mile

The comparisons used for this analysis are from a Hardened section of Feeder to a non-Hardened section of Feeder that are less than a mile apart.

This Feeder was Hardened up to a recloser, and not beyond, due to planning recommendations, and experienced a variety of damage including wind and vegetation. This line is located in southern Miami.

Newton 810366

Hardened:

- No poles down.
- The only wires down were due to a massive tree
- However, this leaning tree did not bring down poles



Non-Hardened:

- Feeder behind the OCR had three broken poles shown below due to wind
- Two stub poles are all that remain and the rest of the poles and wires were behind the berm across the canal





Holy Cross 701937

Below is an example of two pole lines that are running parallel and separated by a couple of lots in Ft. Lauderdale. It appears that the primary damage was from wind.

Hardened (Holy Cross 701937):

- Slightly leaning in rear of due to wind



Non-Hardened (Sample 701932):

- Broken pole





Labelle 502463

Below is a good example of a Hardened wood pole line section compared to a non-Hardened wood pole line section. This pole line is on the West coast just west of Labelle which was a few miles east of where the eye passed. Wind seemed to be the primary cause, as neither section appeared to be related to vegetation or debris.

Non-Hardened (Labelle 502463 – East of SW# 20714)

- Pole line leaning significantly as well as another section that had 2 broken poles. This section of Feeder was not Hardened
- Poles appeared to be 45'/5 or 45'/4 poles, but could not identify pole brand

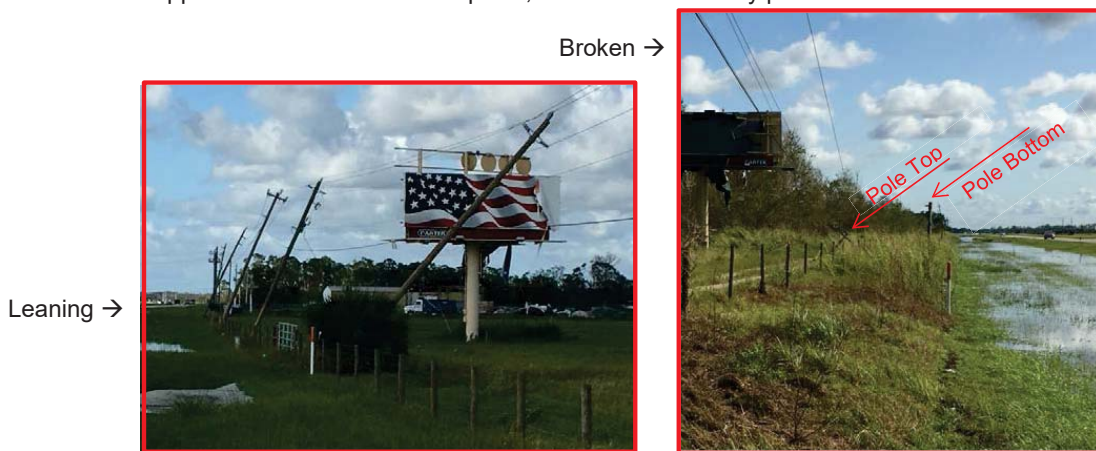

Hardened (Alva Feeder 504761 – West of switch number 20714)

- Section of wood hardened poles that were unaffected by the storm. These poles were not leaning and showed no signs of any damage.





Underground Feeder Performance

Impacts to Underground Feeder performance is generally proportional to the cost and type of the Underground design

Feeder Type	Affected	Population	% Affected
UG Duct / Manhole	54	314	17%
UG Other	23	85	27%
UG URD	8	60	13%
Total	85	459	19%

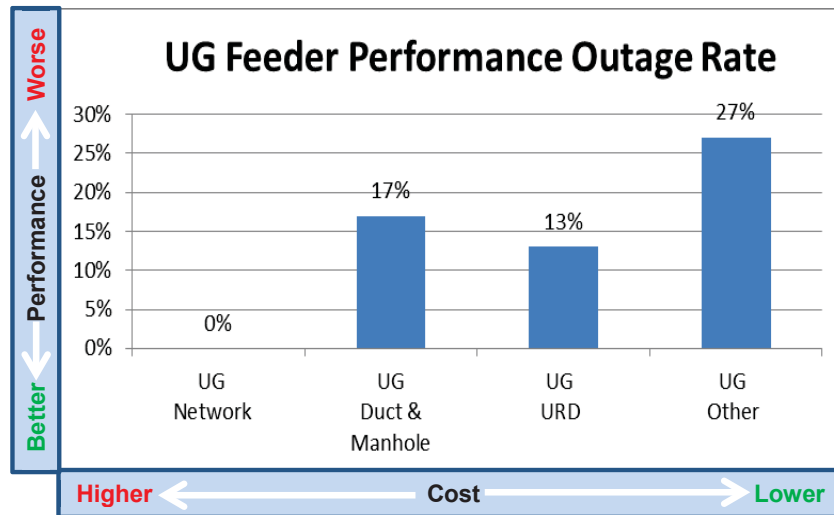

Notes: - Excludes Transmission and Substation Outages
- Source is Carver Data on 9/22/17 at 7:00 am



Lateral Performance

Underground Laterals performed better than Overhead Laterals during Hurricane Irma.

- While UG Laterals make up 55% of the Lateral population, UG Laterals sustained less outages accounting for only 3.6% of the Laterals out
- Based on the assessment of outage performance UG Laterals performed 5.6 times better than OH Laterals.
- Lateral outages do not include outages caused by Feeder, Substation or Transmission

Laterals Out	Affected	Population	% Affected
OH	20,341	84,574	24%
UG	3,767	103,384	4%
Total	24,108	187,958	13%

$$\frac{20,341}{3,767} \div \frac{84,574}{103,384} = \frac{.24}{.04} = 6.6$$

Underground Laterals performed 6.6X better than Overhead Laterals

UG Lateral Performance Ratio	=	$\frac{\text{Number of OHLaterals Out*}}{\text{Total Number ofOH Laterals}}$	to	$\frac{\text{Number UGLaterals Out*}}{\text{Total Number ofUG Laterals}}$
* Affected = Laterals out at least one time				

Laterals Out from Tickets and from Storm Control (SC) Laterals from Patrols

Lateral Type	Lateral Out
SCL	18,074
SCLU	3,433
LAT	2,267
LATU	334
Total	24,108

Overhead Laterals = SCL + LAT
Underground Laterals = SCLU +LATU



Distribution Transformer Performance

Single phase pad mount transformers for Underground systems performed 3.5X better than Aerial transformers on Overhead Systems

Transformer Inspection at CRS

- There are over 930,000 distribution transformers in service:
 - 605,000 aerial transformers
 - 255,000 single phase pad mounted transformers
 - 46,000 three phase pad mounted transformers
- According to Inventory Services approximate net issues for storm Irma were as follows:
 - 4033 aerial transformers = 0.667% failure rate
 - 481 single phase pads = 0.189% failure Rate
 - Therefore UG performed 3.5X better than OH transformers
 - $(0.667/0.189)=3.5X$
- Mostly Aerial distribution transformers were impacted by Hurricane Irma. Much less Underground transformer damage has been reported and observed.

Inspection at CRS:

- The observed aerial transformers mainly fall in two categories:
 - Broken insulator/bushings due to trees and flying objects
 - Extensive physical deformation due to impact or fall due to broken pole

Broken bushings



Bent frames



- It is estimated by Inventory Services that approximately 4000 aerial transformers were issued due to damage caused by trees, flying objects, or damaged as a result of falling with the broken pole in which they were installed.



Underground Transformers (Single and Three Phase Pads):

- Thirty 3-phase pads with corresponding dates that could be associated with Hurricane Irma. No Physical observation on 2 while 1 had a primary bushing damage suggesting possible cable pulled by uprooted tree/falling riser pole.
- Less than 30 single phase pads with corresponding dates that could be associated with Hurricane Irma. No outside observations on them other than some rust and one unit had been physically hit by debris. We were not able to open them due to how they are stored next to each other and banded closed. Most of them were drained by environmental prior to shipping as is customary.
- It is estimated by Inventory Services that approximately 500 Underground transformers were issue due to Storm Irma. Less number of Underground transformers were observed at CRS and issued postulating that the hurricane did not cause as significant damage to the Underground transformers as to the Overhead.

Transformer Interruptions

	TX Total	OH TX	UG TX
Interruptions	10,594	8,061	2,533

Padmounted Transformer Analysis

The primary damage was due to:

- Flooding
- Up-rooted trees
- Debris falling onto equipment

Percentage of UGTX failures on Hybrid vs. UG Feeders

- The % Outages of UGTX on UG Feeders (0.34%) is better than the % outages of UGTX on Hybrid Feeders (0.78%)
- Source Carver Report

% of UGTX Failures	Hybrid	UG
Outages	2,303	43
System	294,652	12,619
% Outage	0.78%	0.34%

Percentage of UGTX failures on 23KV vs. 13KV

- The % Outages of UGTX on 23KV (0.5%) is better than the % outages of UGTX on 13KV (1.2%)
- Source Device File

% of UGTX Failures	13KV	23KV
UGTX Outages	1,558	799
UGTX System	133,325	175,657
% Outage	1.20%	0.50%



Underground facilities were also impacted by vegetation

Before Restoration



After Restoration





Pad-Mounted Switch Performance

Pad Mounted Switches

- There were minimal pad-mount switch failures related to the storm
- Information based on teams reviewing trouble tickets, materials that were issued, and reports from the areas
- No failed switches were sent to the Reliability Assurance Center for RCA (Root Cause Analysis)



Case Study – Miami Network

The Miami Network performed well with no breaker operations during Hurricane Irma.

The Miami Network is an Underground electrical network that assures service continuity in 120/208 and 277/480 volt Y connected secondary network systems. These systems, in either distributed grid or spot network form, are commonly used in such areas of high load density as metropolitan and suburban business districts.



Streets of downtown Miami

The FPL downtown Miami Network System consists of :

- 11 dedicated primary Network Circuits (Feeders)
- 104 transformers in 32 vaults
 - Each transformers with its own protector
 - Fire protection systems in all 480/277 Spot Network vaults.

TRANSFORMER SIZE	TRANSFORMER QTY	VAULTS QTY	BELOW GRADE QTY
208/120	45	18	10
480/277	74	15	0
Total	104	32	10

After seeing the impact of Superstorm Sandy, much of the equipment that was not already submersible has been changed out to be submersible. Many of the sidewalk vaults are being eliminated.

Downtown Miami experienced surface flooding from hurricane tidal surge impacts, which were generally reported east of NE 2nd Avenue, from the Edgewater area south to SE 15th Road. The flood heights were reported to reach roughly 2 feet above existing grade in some areas. Guided by the news reports, areas within this zone were visually inspected to determine a more detailed delineation of the flooding extent and whether Distribution Network and ground equipment in these select areas experienced flooding. The estimated limits of surface flooding from this assessment, along with visual evidence of flood intrusion into the Distribution equipment are shown in **Exhibit 1**.

Sixteen of 34 Network locations provided by Distribution were observed as shown in **Exhibit 2**. In most cases, the specific location was not accessible but the area was observed for evidence of surrounding flooding and noted. Three of these locations had evidence of roughly 2 feet flood height above the road elevation outside the Network equipment location.

Of the above-ground Distribution equipment locations observed in select areas north of the Miami River, three of these locations are assumed to have experienced flooding ranging from 12" to 18" of depth. These locations are shown in **Exhibit 1**. South of the Miami River, vault locations in buildings were inaccessible, but flooding estimations were made.



Case Study – Miami Network

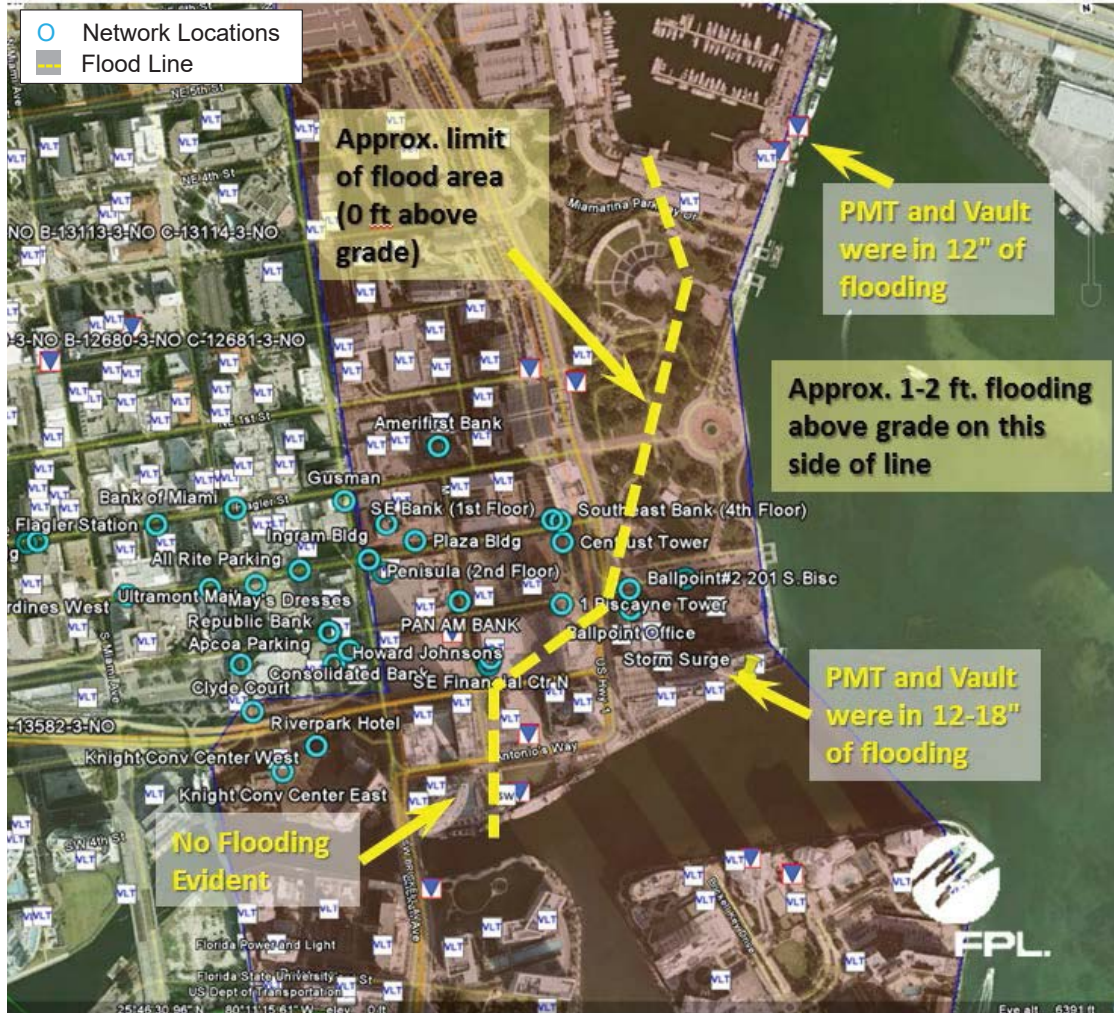

Exhibit 1: Flood intrusion into the Distribution Equipment in Miami



Case Study – Miami Network

GRID	NAME	VAULT #	ADDRESS	SUBMERSIBLE (3/3/14)	LOCATION FOUND (ACCESSIBLE)	SURROUNDINGS AREA FLOODED (APPARENT)	APPROX. FLOOD HEIGHT ABOVE GRADE
Main 208V	Knight Conv Center West	C4	400 SE 2 AVE (R/O)	No	YES (inside alleyway)	No	NA
Main 208V	Plaza Bldg	C25	245 SE 1 ST (ALLEY)	Yes	No (alleyway gate close)	No	NA
Main 208V	Ingram Bldg	C28	25 SE 2 AVE. - MEZZANINE	2 Yes, 2 No	Not Accessible	No	NA
Main 208V	Peninsula Federal	C43	200 SE 1 ST	Yes	Not Accessible	No	NA
Main 208V	Riverpark Hotel	C51	321 SE 1 AVE (N SIDE)	Yes	Yes	No	NA
Main 208V	PAN AM BANK	T10	180 SE 3RD AVE	Yes	Not Accessible	No	NA
Main 480V	Knight Conv Center East	C5	400 SE 2 AVE (LOADING DOCK)		Yes (in loading dock)	No	NA
Main 480V	Centrust Tower	C50	151 SE 3 ST	No	Not Accessible	No	NA
Main 480V	Hotel Intercontinental	C58	150 CHOPIN PLAZA	Yes	Yes (more that 4 feet above grade)	Yes	1 to 2 feet
Main 480V	Ballpoint Office	C59	100 CHOPIN PLAZA	2 Yes, 4 No	Not Accessible	Yes	1 to 2 feet
Main 480V	SE Financial Ctr N	C61	325 SE 3RD ST (SW Corner of Bldg)	No	Not Accessible	No	NA
Main 480V	SE Financial Ctr S	C62	325 SE 3RD AVE.	No	Not Accessible	No	NA
Main 480V	SE Bank (1st Floor)	C65	100 SE 1 ST (100 S. BISCAYNE BLVD)	No	Not Accessible	No	NA
Main 480V	Ballpoint#2 201 S.Bisc	C66	201 S. Biscayne	No	Not Accessible	Yes	1 to 2 feet

Exhibit 2: Network locations in Miami



Case Study – Miami Network

- Examples of Brickell Ave and the Financial District



Source: From Miami Herald



Image from https://www.youtube.com/watch?v=rDY_VQrCC1o



Image from https://www.youtube.com/watch?v=rDY_VQrCC1o



2' deep at SE 12th St & Brickell Ave (Mike Seidel Twitter Feed)



Waves crash at mouth of Miami River at Biscayne Bay (AP)



Case Study – Miami Network

Below is one of the vaults after the water was pumped out (200 SE 15th Road, 8VC13102.) It is the vault for Brickell Harbour, which is a subgrade vault. The water level (noted by the red line) never reached the spades of the transformer nor the bottom of the fuse cabinets, so it remained in service. Actually, none of the flooded network vaults lost power because of Hurricane Irma.

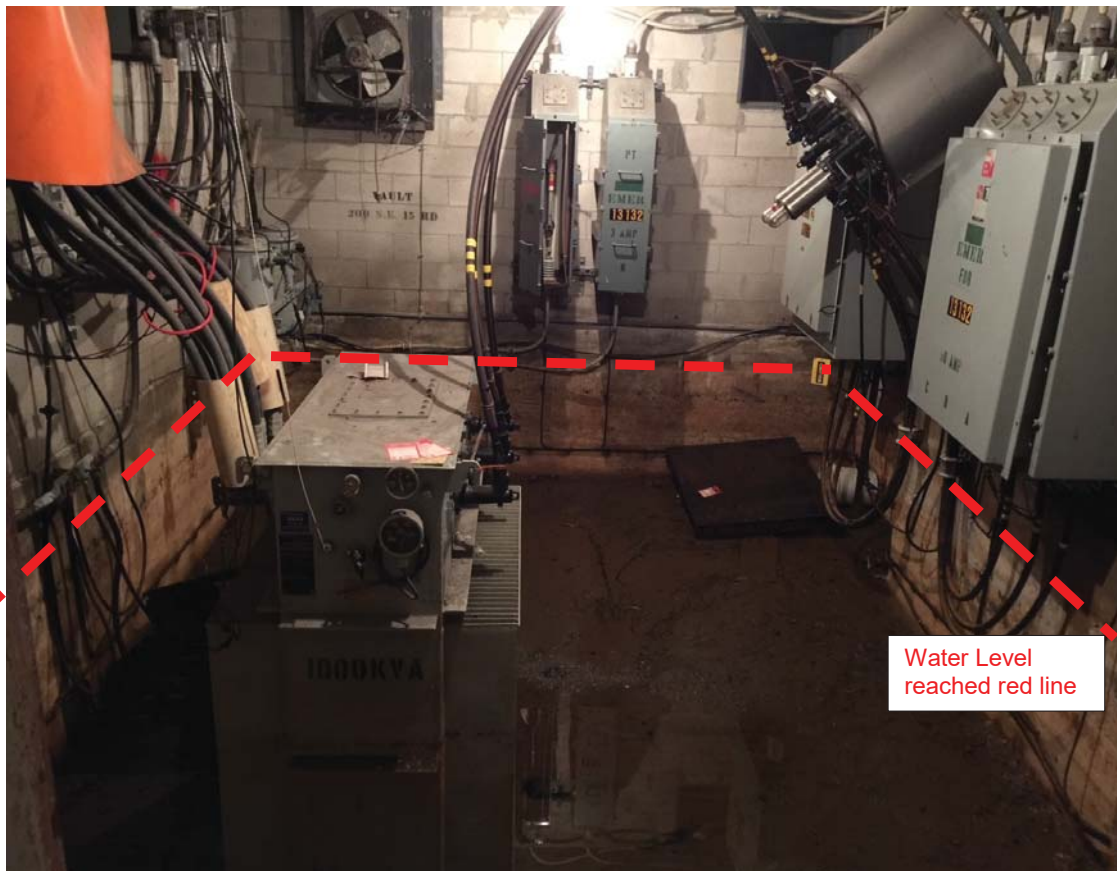

Subgrade Vault for Brickell Harbour



Smart Grid

AFS (Automated Feeder Switch)

Automatic Feeder Switches (AFS) isolate, transfer load, interrupt faults and have pulse close capabilities. They automatically reroute electricity to reduce the amount of customers affected when an adverse condition affects the power lines.



AFS Performance:

- 546K Customer Interruptions avoided during the storm

AFS device availability was reduced to 33% at the peak of the storm. This occurred naturally through:

- Lost communications due to loss of power
- Damage to switches
- Switches reconfigured in the field

Note the lower effectiveness of the AFS in the West Management Area was due to implementing the Storm process which disables AFS team operations for winds greater than 74mph. The process includes:

- 1) Determining areas in which sustained winds will be greater than 74mph
 - a. West Management Area was the area identified
- 2) Disabling of "Normal Open" switches in those areas to avoid automatic throw-over to alternate feeder.

There were around 250 AFS's that showed offline or "Not Available" after the storm.

- Power Quality patrolled approximately 2,500 AFS's on patrol sweeps.

There were 26 failed AFS's that needed to be replaced

- Over half had physical damage and the rest are other mechanical and/or relay issues



AFS Team Success Rate

Management Areas	CI Avoided	CI on Original Feeder Tickets	Feeder Tickets w/ CI Avoided	# of AFS Feeder tickets	Success Rate
East	171337	822461	158	405	39%
BR	55414	261726	46	116	40%
GS	30967	159998	28	82	34%
PM	27206	117595	30	62	48%
WB	29191	150918	29	78	37%
WG	28559	132224	25	67	37%
North	157043	685010	145	369	39%
BV	49547	198825	49	106	46%
CF	46151	205100	41	115	36%
NF	25783	100924	24	55	44%
TC	35562	180161	31	93	33%
South	110753	601079	124	353	35%
CE	22072	138108	28	80	35%
ND	18297	103835	21	64	33%
SD	33507	189504	41	120	34%
WD	36877	169632	34	89	38%
West	107165	653774	71	241	29%
MS	42448	194374	29	81	36%
NA	37058	295988	23	98	23%
TB	27659	163412	19	62	31%
Grand Total	546298	2762324	498	1368	36%

Naples is where the storm made landfall

Success Rate indicates self-healing from primary circuits to backup circuit



ALS (Automated Lateral Switch)

Automatic Lateral Switches (ALS) clear temporary faults, provides enhanced protection and coordination. During storm events with extreme winds for extended period of time, ALS performance is similar to a fuse.



ALS Forensics

- Over 60% of ALS that were returned were operational

ALS Analysis : 358 units

- 136 No Trouble Found
- 60 units were flashed or had evidence of tracking - most were operational
- 47 true failures
- 35 units returned due to cold load pickup concerns - operational
- 28 units had physical damage

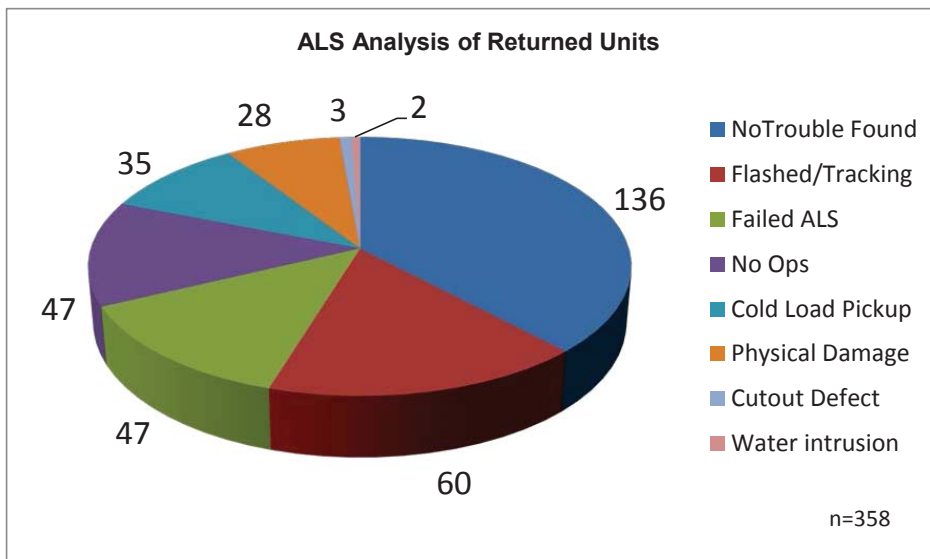



Vegetation

Overview - Vegetation was the leading cause of pole and wire damage

- 57% of tree failures were caused by up-rooting trees or trunk failures falling into overhead facilities
- The remaining 43% of tree failures were due to broken limbs
- Additional trimming by FPL or shorter vegetation trimming cycles would not have made a significant impact to the system performance since the majority of damage was caused by uprooted trees, broken trunks and broken limbs that fell into the lines from outside of right-of-way.
- Over 6,000 reports were reviewed in ESDA (Electric Storm Damage Assessment) and 1,700 of these observations were referred to arborists to classify.

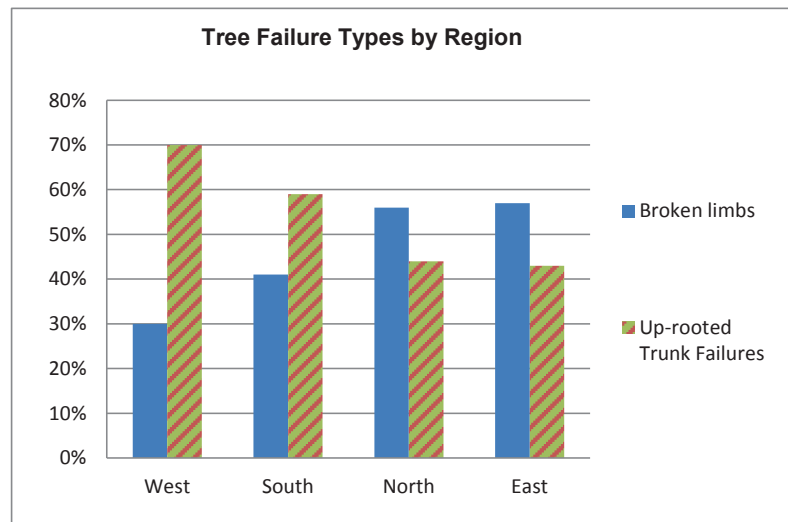
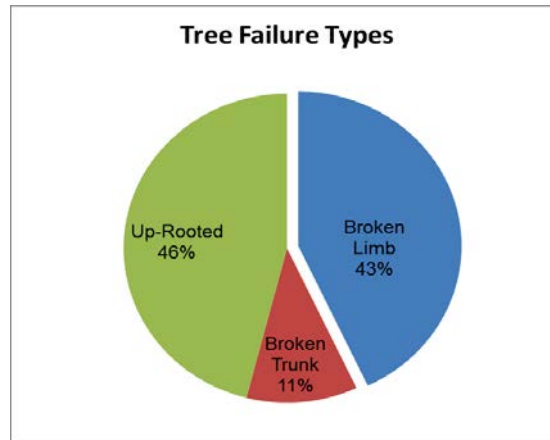



Tree Characteristics

Native Trees

Oak – Typically storm resilient unless they are older and larger

Pine – Older trees are significantly less storm resilient

Non-Native and Exotic Trees

Ficus - Dense foliage creating increased wind resistance and shallow root system

Australian pine – Less flexible limbs, shallow root systems, low survival rates due to storms

Melaleuca – Less flexible limbs, shallow root systems, low survival rates due to storms

Palm – More storm resilient, however typically shed palm fronds

Mango – Large non-native fruit tree with low wind resistance

Acacia – Tall tree prone to large branch failure

Damage due to larger tree size based on ESDA observations

- Generally less storm resilient
- Large trees outside Right-of-Way fell into FPL facilities
- Downed larger trees require special equipment and additional time for clean up
- Downed larger trees blocked access and delayed restoration

Damage due to tree location based on ESDA observations

- In many cases Right Tree Right Place (RTRP) guidelines not followed
- Large trees outside Right-of-Way fell into FPL facilities

Damage due to Ground Conditions based on ESDA observations

- Saturated ground reduced soil friction and root holding ability

ESDA App (Electronic Storm Data Assessment) is the mobile data collection tool that FPL used to capture damage on storm patrols.

University of Florida Study Wind and Trees: Lessons learned from Hurricanes published by UF Institute of Food and Agriculture Sciences (IFSA) show that native trees typically fair better than non-Native trees in South Florida during storm.



Tree and Vegetation Damage Patrol Observations and Analysis

(Data collected from ESDA)

Observation	Dade	East	North	West
% of tree damage For Native and non-Native trees	Native 20% Non-Native 80%	Native 30% Non-Native 70%	Native 70% Non-Native 30%	Native 55% Non-Native 45%
% of tree damage by tree type	Ficus 23% Palm 10% Aust. Pine 9% Black Olive 7% Oak 6% Avocado 5% Mango 5% Bischofia 4% Royal Poin. 3% Bean Tree 3% H.K. Orchid 3% Vine 3% Other 20%	Ficus 24% Aust. Pine 13% Oak 11% Palm 7% Melaleuca 6% Pine 6% Back Olive 4% Brazi.Pepper 4% Acacia 2% Java Plum 2% Vine 2% Other 18%	Oak 43% Pine 21% Palm 8% Hardwood 5% Aust. Pine 5% Other 19%	Pine 30% Oak 16% Ficus 9% Palm 7% Melaleuca 6% Acacia 5% Aust. Pine 5% Carrotwood 4% Other 19%
Primary damage	Up-rooted trees and broken trunks	Broken Limbs	Broken Limbs	Up-rooted trees and broken trunks
% of primary damage	59%	57%	56%	70%
Secondary damage	Broken Limbs	Up-rooted trees and broken trunks	Up-rooted trees and broken trunks	Broken Limbs
% of secondary damage	41%	43%	44%	30%
Ground Condition	Saturated			Saturated
General Comments	Access was an issue due to large number of exotics which are less storm resilient	Higher percentage of non-native and exotics are less storm resilient	Larger and older trees which are typically less storm resilient	Larger and older trees which are typically less storm resilient, High winds and saturated soil caused storm resilient trees to fail such as palms



Examples of Vegetation Damage in Dade Area





Examples of Vegetation Damage in East Area





Examples of Vegetation Damage in North Area





Examples of Vegetation Damage in West Area





Vegetation Trimming Guidelines - Specifications and Guidelines for Clearances

Planting the Right Tree in the Right Place (RTRP) reduces pruning requirements

However, when we need to trim, we follow all industry guidelines

- **Directional pruning:**
 - Removes limbs growing towards the conductors
 - Trains the tree to grow away from the facilities
 - Removes limbs at natural detachment points, or laterals, to help facilitate sealing to prevent decay
- **Removal:**
 - Necessary if pruning cannot be maintained
 - Palms

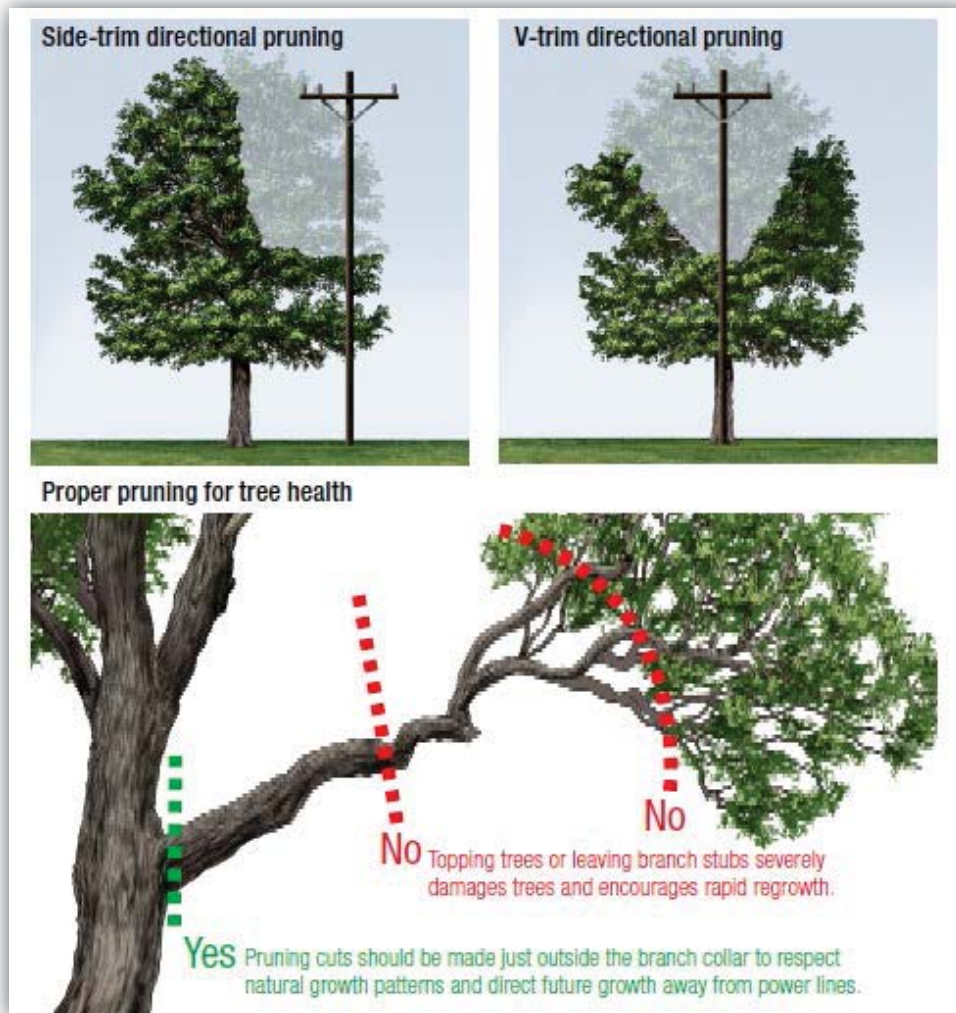



Case Study – High Density Foliage areas in South Florida “Rear-of-Service”

Existing Conditions and Limitations

- Many large trees are in close proximity to utility lines and outside rights-of-way and easements
 - Wrong tree planted in the wrong place (including new and young trees)
 - Many non-native trees have less wind resistance and break or blow over in high winds
- Some communities have advised that “Right Tree Right Place” (RTRP) does not meet the characteristics of the city.
- Pressure from some communities on FPL to perform minimal trimming so it does not impact aesthetics.

Possible Solutions

- Adopt ordinances that support keeping vegetation away from utilities
- Cities should have strategy to maintain trees for storm (thin out tree for storm resilience)
- Plant only right tree right place (RTRP)
- Partner with customers and municipalities to identify trees in need of removal or relocation that are wrong tree wrong place



Case Study – Coral Gables

The city has a long history focused on aesthetics, tree lined streets, and green spaces which has resulted in many large canopy trees adjacent to power lines in easements. During storm, large mature banyan trees topple over and crash into facilities from far beyond the FPL line clearing trim zone. At the start of restoration, many line trimming crews were initially clearing trees to allow for access to roads and FPL facilities. The city's vision continues to have tree lined streets with high tree density around utilities (e.g., the Tree Succession Plan).

Recommendations:

- Prior Lessons Learned from the 2004 and 2005 storm seasons, older trees are more likely to fail in hurricanes and over-mature trees should be removed and replaced by new trees. Source: "Wind and Trees: Lessons Learned from Hurricanes" published by UF Institute of Food and Agriculture Sciences (IFSA).
- Follow Right Tree Right place guidelines and stop actively planting large canopy trees adjacent to power lines.
- Adopt ordinances that support keeping vegetation away from utilities



Pictures above:
Large, mature ficus trees topple over due to massive tree canopy with shallow root systems

Pictures to the right:
Young canopy trees (i.e. oak) and palms planted in the wrong place and will impact facilities in the future





Case Study – West Florida

Tree failure in West Florida included many large older trees, which studies have shown are less storm resilient. Large trees may require specialized equipment to remove, slowing restoration. High wind and saturated soil may have contributed to high rate of tree failure, as even more wind resistant trees such as palms were more likely to fail.

Recommendations:

- Prior Lessons Learned from the 2004 and 2005 storm seasons, older trees are more likely to fail in hurricanes and over-mature trees should be removed and replaced by new trees. Source: "Wind and Trees: Lessons Learned from Hurricanes" published by UF Institute of Food and Agriculture Sciences (IFSA).
- Follow Right Tree Right place guidelines and stop actively planting large canopy trees adjacent to power lines.
- Adopt ordinances that support keeping vegetation away from utilities

Large trees and palms topple over onto from outside the utility trim zone



Trimming crews use a crane to remove large tree from utility lines





Restoration and Storm Comparisons

FPL Restoration Milestones

Restoration Milestones	
1M restored	3PM, Monday 9/11 Day 0
2M	6PM, Tuesday 9/12 Day 1
3M	4AM, Thursday 9/14 Day 3
4M	7AM, Sunday 9/17 Day 6

FPL Restoration comparing Irma to Wilma

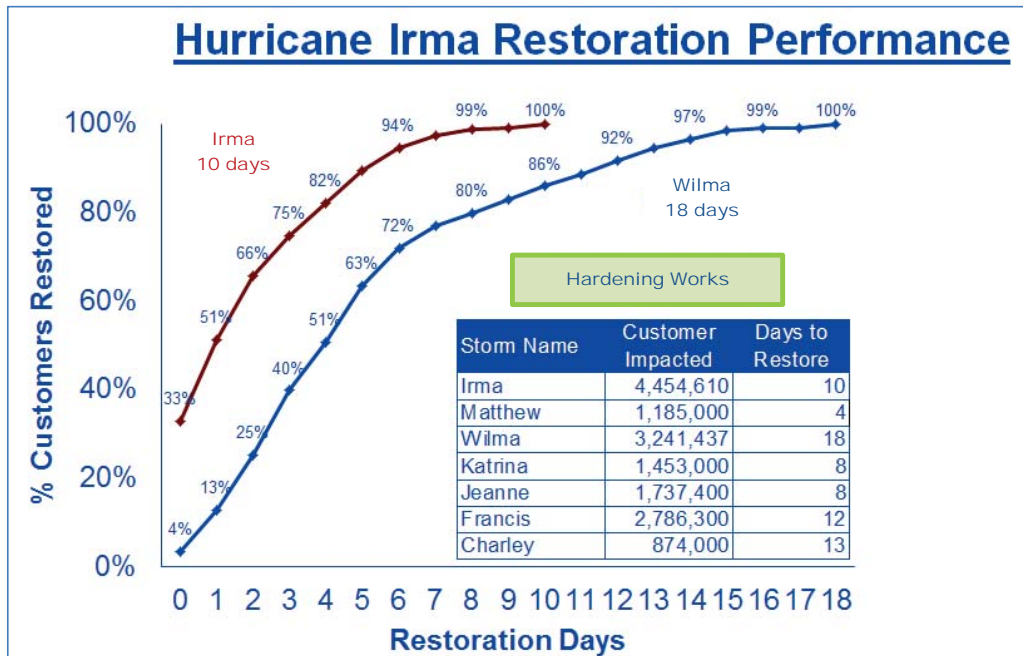



Restoration and Outages by County (All Utilities)

Although the percentage of Florida customers without power during Irma was higher than during Wilma, the rate of electric service restoration has been more rapid.

Source: U.S. Energy Information Administration based on data from [Florida Division of Emergency Management](http://www.fdeem.com) and [NOAA National Hurricane Center](http://www.noaa.gov)
<https://www.eia.gov/todayinenergy/detail.php?id=32992>

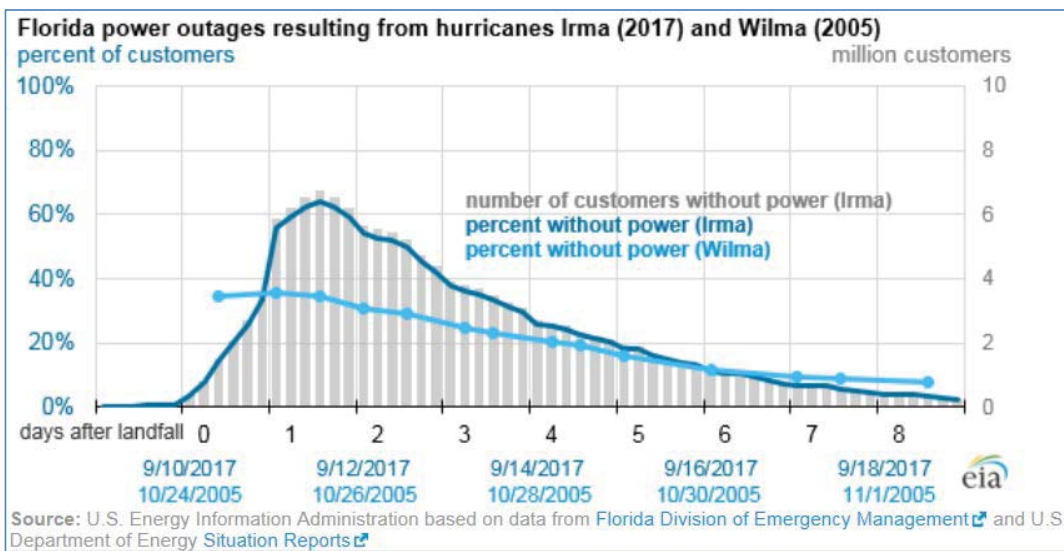
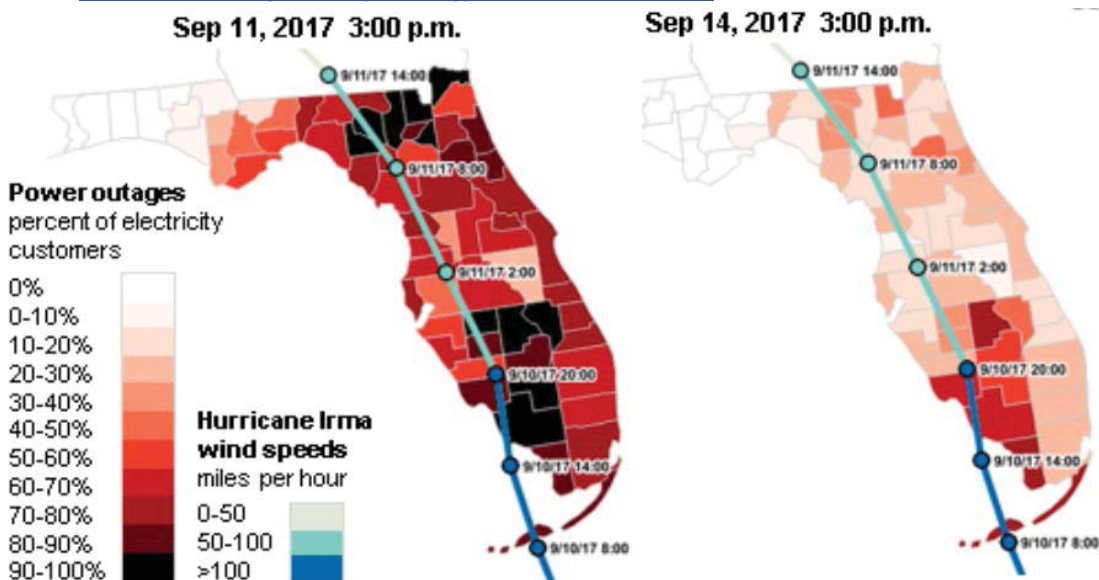



FPL Restoration Hurricane Wilma vs. Irma

- Hurricane winds (74+ mph)
- Strong tropical storm winds (55-73 mph)
- Strong tropical storm winds (55-73 mph)

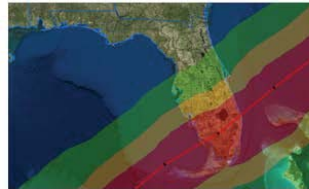

Hurricane Wilma, 2005

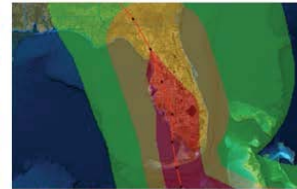

Hurricane Irma, 2017

	Hurricane Wilma, 2005	Hurricane Irma, 2017
Saffir-Simpson Scale	Category 3	Category 4
Maximum sustained winds in Florida	120 mph	130 mph
Cyclone damage potential index*	2.8	4.3
FPL counties impacted	21	35
Customer impacted	3.2 million	4.4 million
% of FPL customers	75%	90%
Poles damaged*	12,419	4,561
Sub-stations de-energized	241	92
Sub-stations restored	5 days	1 day
Customer restoration	18 days	10 days
50% of customers restored	5 days	1 day
75% of customers restored	8 days	3 days
95% of customers restored	15 days	7 days
Average customer outage	5.4 days	2.1 days

*Irma and Wilma pole counts represent the poles replaced during restoration and follow up work. Irma number is preliminary as follow up work is ongoing



Transmission and Substation Storm Comparison (Wilma vs. Irma)

	Wilma	Irma	% Improvement
Substations Out	241	92	62%
Substations Out due to Lines	227	86	62%
Transmission Line Sections Out	345	215	38%
Transmission Line Sections with work required	117	48	59%
Tree	22	29	-32%
OHW	58	6	90%
Transmission Structures	100	5	95%
500KV Structures	30	0	100%
Debris	49	3	94%
Contamination	0	1	
Foreign Substation	0	1	
Station Arrestor	0	1	
Cross Arms	7	0	100%
Insulators Replaced (Structures)	101	28	72%
Ceramic Posts (CPOC)	68	0	100%
Ceramic Suspension	14	7	50%
Polymer Post	6	17	-183%
Polymer Suspension	13	4	69%

Source:
Wilma info - Wilma T&S PPT
Irma – TSCC Storm Central



Distribution Storm Comparison (Irma vs. Wilma)

Distribution Impacts	Irma	Wilma	% Change
Distribution Poles *	4,561	12,419	63%
AFS CI Avoided	546,000	0	
Counties Affected	35	21	
Miles of Wire	1,300	1,016	-28%
Transformers	4,596	6,330	27%

* Irma and Wilma pole counts 4,561 and 12,419 respectively represent the poles replaced during restoration and follow up work. Irma number is preliminary as follow-up work is ongoing. Irma poles replaced during restoration is 2860. The comparable figure for poles replaced during restoration for Wilma is not available, as FPL did not track or maintain this information prior to or at the time of Hurricane Wilma.

Distribution Storm Comparison (Last 6 Largest Storms)

	Charley	Frances	Jeanne	Wilma	Matthew	Irma
Customers Interrupted	874 K	2,786 K	1,737 K	3,241K	1,185K	4,455 K
Pole Counts	6,878	3,757	2,227	12,419	656	4,561*

*Preliminary

Primary Pole Failure

- Irma - Vegetation and Poor Soil Conditions (84%)
- Wilma - Wind and Pole Deterioration (77%)

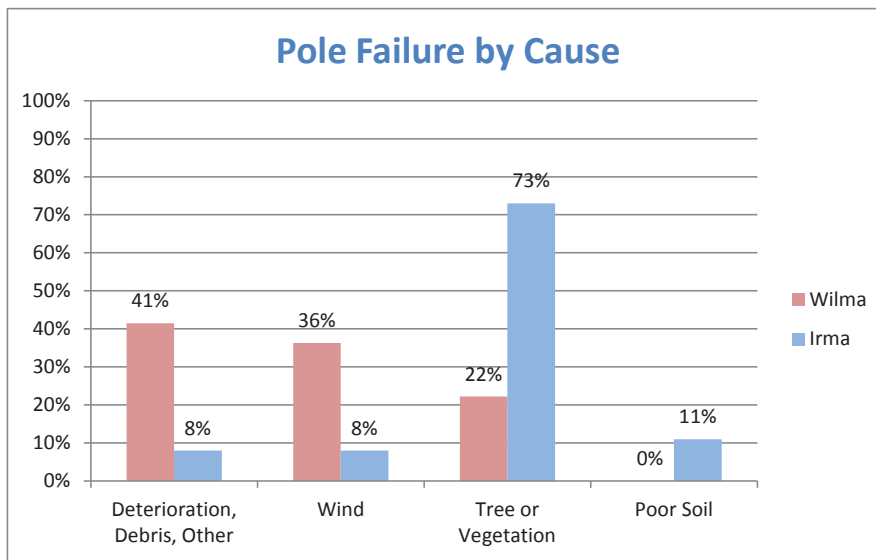



Other





Forensics

Data Collection Findings / Number of Patrols (using ESDA app unless noted)

- Drive-in (Did not use ESDA App) 183 Findings / 129 Patrols
- RPA (Rapid Patrol Assessment)*26,340 Findings / 1527 Patrols
* Paper Patrols converted to ESDA
- ALP (Advanced Lateral Patrol) 11,087 Findings / 714 Patrols
- Forensic 601 Findings / 522 Patrols

Background and Philosophy

FPL's Storm Forensic Organization was formed after the 2004-2005 active storm seasons to help evaluate Distribution infrastructure performance during extreme wind weather events. The data collected serves to meet FPL commitments to the FPSC which include annual summary reporting of infrastructure performance during hurricane events.

The field forensic teams were created to investigate affected areas and collect damage information to analyze performance of:

- Hardened Feeders
- Overhead Feeders
- Overhead vs. Underground Laterals

Note: Forensic investigations exclude locations under safety, property damage or other special investigation teams

Irma Activation

Based on the projected path and intensity of Irma the Forensics Team was pre-activated, but not pre-positioned. As the storm passed from the Southwest to the North, the teams were deployed as conditions improved and were acceptable to begin patrol.

ESDA

Since communications were not down, FPL incorporated the use of the ESDA (Emergency Storm Damage Assessment) App on their smart device to collect data on the impacted Hardened Feeders.

- For the first time, patrollers completed over 34,000 damage assessments digitally, drastically reducing the time it takes to understand damage and deploy the right resources
- On one day, we had just under 800 concurrent users
- All Hardened Feeders impacted, that were not related to substation or transmission outages, were patrolled using ESDA



Hardened Feeders

The primary objective of hardening is to reduce restoration times by minimizing the number of pole failures during extreme wind weather events. Pole failures typically lead to extended restoration times and longer outages. As a result, FPL forensic investigators use pole failure rates as the primary measurement criteria to evaluate performance of Hardened vs. non-Hardened Feeders within the impacted areas. Feeder field forensic data was collected to conduct root cause analysis and failure mode of previously Hardened Feeders that locked out during the storm. All calculations are based on field data collected from ESDA patrols.

Overhead Feeders

Investigation of selected Overhead Feeders impacted by extreme wind events is an annual reporting requirement to the FPSC. Inspection locations are defined based on selected routes within the path of the storm. The objective of inspections is to collect sample data on selected Feeder locations in order to evaluate infrastructure performance during extreme wind events. Field data from ESDA patrols, TCMS and other sources will be utilized.

Overhead vs. Underground Performance

The investigation and performance of Overhead vs. Underground infrastructure during extreme wind events is an annual reporting requirement to the FPSC. Forensic investigators examine selected Underground or Overhead Lateral facilities that were affected within the path of the storm. The objective of these inspections is to collect sample data from Overhead or Underground damage locations in order to evaluate and compare infrastructure performance of Overhead and Underground facilities during extreme wind event. Field data from ESDA patrols, TCMS and other sources will be utilized.

Defining Storm Affected Areas

The emergency preparedness department performs the storm tracking activities from forecast to actual storm path. This information is available to the GIS group Technology Coordinator and is used to identify the storm affected area. Prior to a storm event, the Forensic Leads and the Technology Coordinator will be in close contact to execute the below plan based on the latest possible forecast or pre-storm plan. After the storm has passed, the Forensics Team executes the pre-storm plan unless the actual event was significantly different, at which time a new plan based on the actual storm path will be developed.

Irma affected FPL's entire service area including:

Southeast Areas:

Central Dade	North Dade	South Dade
West Dade	Central Broward	North Broward
South Broward	Boca Raton	West Palm

North Management Areas:

Treasure Coast	Brevard	Central Florida
North Florida		

West Management Areas:

Manasota	Naples	Toledo Blade
----------	--------	--------------



Smart Grid Forensics (Pre Storm)

Objective:

1. Assess storm impacts to DA (Distribution Automation) Smart Grid equipment
2. Support restore of DA Smart Grid equipment after power has been restored

72 Hour Pre-Storm Checklist

- Activate field smart grid forensics team & confirm ability to travel. Update PREPS
- Notify contractors of storm efforts; Develop preliminary Forensics resource capabilities
 - S&C: Contact S&C – request full roster (name, contact info, employee id, vehicle # & type, qualification/title, years of employment).
- Contact Design & Standards for any available secondary support & time frame of availability
- Check equipment (laptops)
- Verify Storm Safety and Current Stock levels
- Verify DA battery stocks with Power Quality
- Review M&S Number Lists

48 Hour Pre-Storm Checklist

- Identify Work location for team & secure access: Service Center for team to check-in post storm. Confirm with Forensics Team Leader
- Coordinate logistics (hotel, car rental)
- Take System Status Snapshot
 - AFS Availability
 - How many units are installed but not in service
 - Availability of not in EDNA data historian
 - FCI
 - How many units are installed but not in-service
 - Vault Monitor
 - Capacitor Controller
 - Transformer Monitors
 - TripSavers
- Establish number and list of devices within the storm path

24 Hour Pre-Storm Checklist

1. Contact Smart Grid Forensics team to confirm work location
2. Set up information line for post storm reporting
3. Contact S&C to confirm meeting locations
4. Establish number and list of devices within the storm path



Smart Grid Forensics (Post Storm)

Post Storm 36 hr AFS IntelliRupter Visual and Operational Check.

Storm Name _____ Test Date _____

Switch Number _____

Substation _____

Feeder _____

Verify if item #2 activities can be performed if switch is under Storm Feeder Control instead of Control Center Control.

1. Perform Visual Check of IntelliRupter

- 1.1. IR Base Free of Damage or Flash Marks
 - 1.1.1. Manual Controls Undamaged (Open/Close, RC-Off and Ground Trip Block Levers)
 - 1.1.2. Visual Disconnect (Air Break) Control Rocker Arm and Support Undamaged or Showing Flash Marks
- 1.2. Control & Communication Modules Properly Installed (Arrow Orientation and Properly Seated)
 - 1.2.1. Control Module Status light indicating normal (On for .5 seconds every 30 seconds)
- 1.3. Phase Interrupters Undamaged or Showing Flash Marks
- 1.4. Semaphores Undamaged
- 1.5. Antennae Present and Undamaged
- 1.6. Integral Power Modules (IPM's) Undamaged or Showing Flash Marks
- 1.7. Arresters & Arrester Leads Undamaged and Properly Connected.
- 1.8. Ground connection present to closest pole ground.
- 1.9. Pole Top Position Crossarm, Insulators, By-Pass Switches and other Primary Hardware Undamaged or Showing Flash Marks.

2. Perform Limited Operational Check of IntelliRupter

- 2.1. Call Control Center to notify them of testing at the location.
- 2.2. Provide CC Desk Operator Substation, Feeder and Switch # to be tested
- 2.3. Is switch being scanned?
- 2.4. If yes go to step 2.6
- 2.5. If No, Switch Should Be Bypassed and Referred To PQ TCMS AFS Screens.
- 2.6. Verify Current IntelliRupter Status with Control Center
 - 2.6.1. IntelliRupter Position : Open/Ready _____ Closed _____ Open/Locked
 - 2.6.2. Air Break (Disconnect) : Open _____ or Closed _____
 - 2.6.3. Auto Op: Enabled _____ or Disable _____
 - 2.6.4. RC: ON or OFF (RC-ON = HLT is OFF; RC-OFF = HLT is ON)
 - 2.6.5. Display Voltages per Phase to be within +/- 2 Volts of IT-II remote values
 - 2.6.6. Verify Team Status
- 2.7. If SCADA display does not match IntelliRupter, Switch Should Be Bypassed and Referred To PQ.
- 2.8. Have Control Center Operator Verify Remote Control by
 - 2.8.1. Execute Auto Op Command, Wait for Confirmation, and RTN to position Found
 - 2.8.2. Execute RC Command, Wait for Confirmation, and RTN to position Found
 - 2.8.3. If Either 2.8.1 or 2.8.2 Control Tests Fail, Switch Should Be Bypassed and Referred To PQ.
- 2.9. If no alarms or abnormal conditions, clear manual override with dispatcher.

SCC Tester _____ CC Operator _____

Please provide a copy of completed form to Storm Forensics Team Manager.



Distribution Hardening Programs

Storm Hardening Plan

- The Storm Hardening Plan started in 2006 with 124,128 poles having been hardened through September 2016.
- FPL's Storm Hardening Plan is filed with the PSC.

PIP (Pole Inspection Program)

- The Pole Inspection Program started in 2006 and FPL has:
 - Replaced 79,931 as of 2016 (82,132 as of 2017)
 - Reinforced 47,247 as of 2016 (50,939 as of 2017)
- FPL's Pole Inspection Program is filed with the PSC.

Distribution Design Gust Wind Speeds

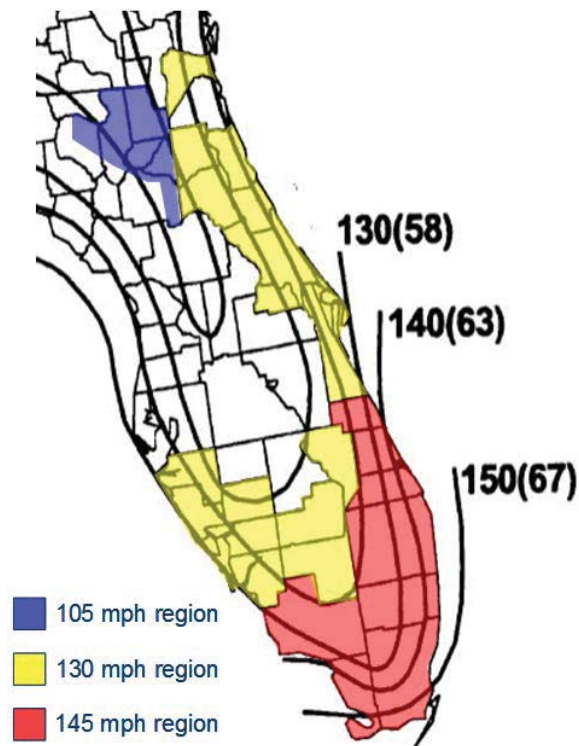



Definitions / Acronyms

Affected - include only one interruption per device (feeder, lateral, transformer, etc) if the device goes out multiple times

ALS – Automated Lateral Switch

AFS – Automated Feeder Switch

Broken or Downed Pole – Cannot carry electricity

Customers Affected - Customers that experienced an outage

CI - Customers Impacted which are customers that may have gone out more than once or nested outages.

CI Avoided – Customer Interruptions Avoided

CMH – Construction Man Hours (Labor)

DA – Distribution Automation

D&S – Design and Standards which coordinate the forensic operations and forensic patrols

ESDA - Electric Storm Damage Assessment is a mobile app and primary tool that facilitated the collection and characterization of the major types of damage on the Distribution system.

Hybrid Feeder - Combination of Feeder and Lateral miles between 5% - 95% UG

Interruptions - Total number of customer outages

Mean Higher High Water (MHHW) – An average of higher high water heights over time. Numbers are reported as the value above that regions value.

NHC – National Hurricane Center

NOS – National Ocean Service

OH Feeder - Combination of Feeder and Lateral miles < = 5% UG

RCA – Root Cause Analysis

UG Feeder - Combination of Feeder and Lateral miles > = 95% UG